

## A Comparison of Two Panasonic Lithium-ion Batteries and Cells for the IBM Thinkpad

Judith A. Jeevarajan<sup>a</sup>, Joseph S. Cook<sup>a</sup>, Jacob Collins<sup>b</sup>,  
Frank J. Davies<sup>c</sup>, Bobby J. Bragg<sup>b</sup>

<sup>a</sup> Lockheed Martin Space Operations, Houston, TX

<sup>b</sup> NASA-Johnson Space Center, Houston, TX

<sup>c</sup> Hernandez Engineering, Houston, TX

The IBM Thinkpad 760XD has been used in the Orbiter and International Space Station since 2000. The Thinkpad is powered by a Panasonic li-ion battery that has a voltage of 10.8 V and 3.0 Ah capacity. This Thinkpad is now being replaced by the IBM Thinkpad A31P which has a Panasonic li-ion battery that has a voltage of 10.8 V and 4.0 Ah capacity. Both batteries have protective circuit boards.

The Panasonic battery for the Thinkpad 760XD had 12 Panasonic 17500 cells of 0.75 Ah capacity in a 4P3S configuration.<sup>1</sup> The new Panasonic battery has 6 Panasonic 18650 cells of 2.0 Ah capacity in a 2P3S configuration.

The batteries and cells for both models have been evaluated for performance and safety. A comparison of the cells under similar test conditions will be presented. The performance of the cells has been evaluated under different rates of charge and discharge and different temperatures. The cells have been tested under abuse conditions and the safety features in the cells evaluated. The protective circuit board in the battery was also tested under conditions of overcharge, overdischarge, short circuit and unbalanced cell configurations. The results of the studies will be presented in this paper.

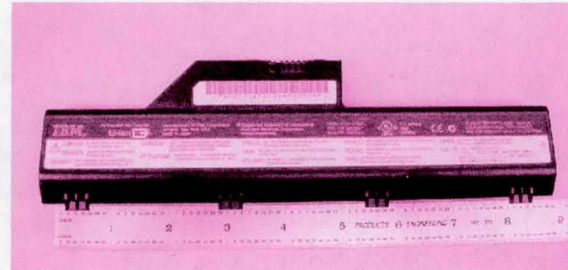
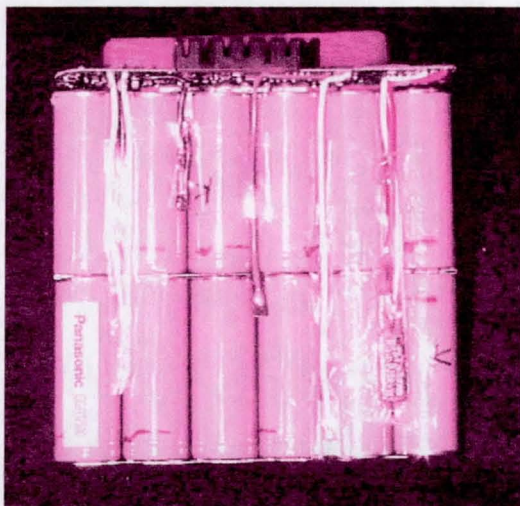

Figure 2. Panasonic Battery for the IBM Thinkpad A31P.

### References:

1. J. A. Jeevarajan, F. J. Davies, S. M. Lazaroff and B. J. Bragg, *Proceedings of the 39<sup>th</sup> Power Sources Conference*, Cherry Hill, NJ, June 2000.





# COMPARISON OF PERFORMANCE AND SAFETY OF TWO MODELS OF PANASONIC LI-ION BATTERIES

The 203<sup>rd</sup> Electrochemical Society Meeting  
April 27-May 2, 2003

Judith A. Jeevarajan, Joseph S. Cook

*Lockheed Martin/NASA-JSC*

Francis J. Davies,

*Hernandez Engineering*

Jacob Collins and Bobby J. Bragg

*NASA-JSC*



## INTRODUCTION

- \* The first set of Panasonic Batteries for the IBM Thinkpad Model 760 XD was certified in 1999.
- \* The information was presented at the 39<sup>th</sup> Power Sources Conference in 2000.
- \* Cells contained in this battery were CGR17500 and were in a 4P3S configuration with capacity of 3.0 Ah and 10.8 V.
- \* The latest IBM Thinkpad A31P has a new Panasonic Li-ion battery with CGR 18650 cells.
- \* The battery has a 2P3S configuration with a capacity of 4.0 Ah and 10.8 V.
- \* Performance tests at different rates and different temperatures were carried out.
- \* Abuse tests under different abuse conditions were carried out to determine their safety tolerance.



## Panasonic Lithium-ion IBM Thinkpad Battery 760 XD

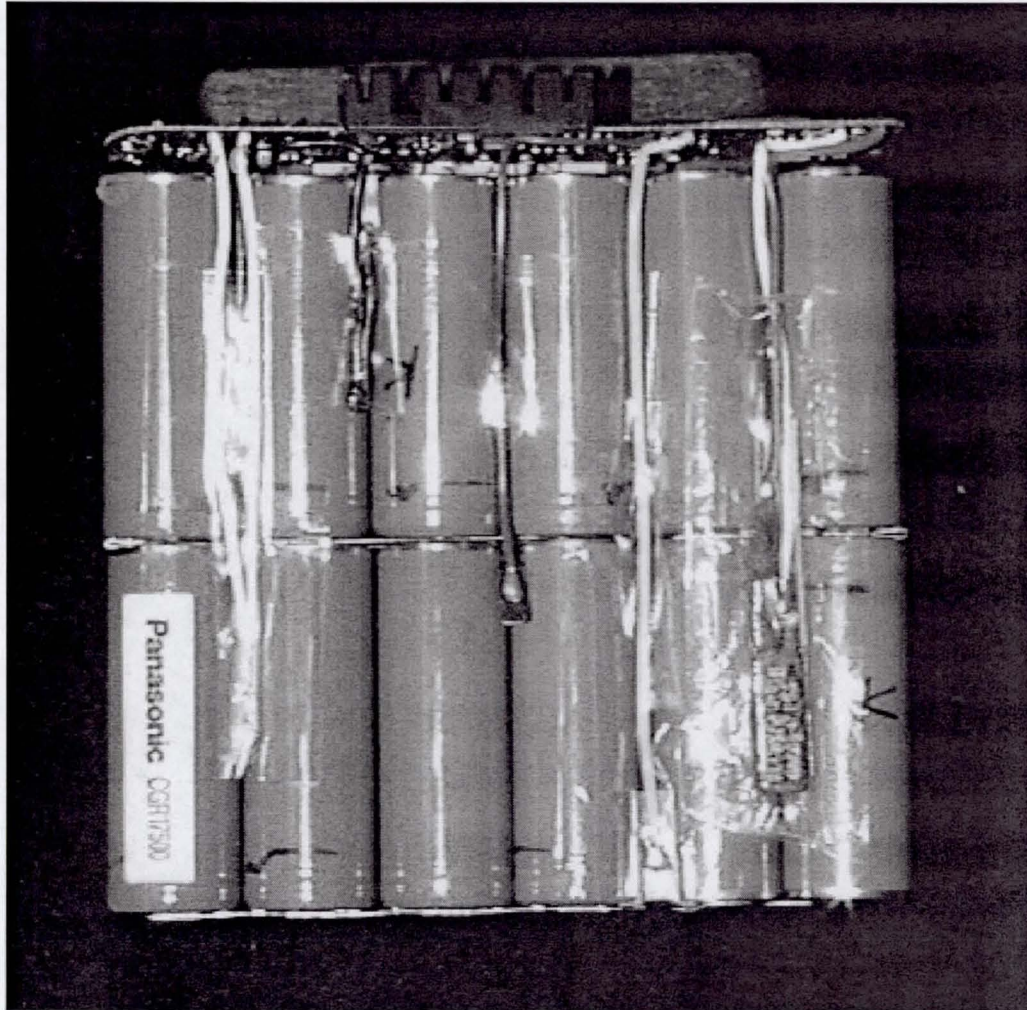

Weight: 366 g

Dimensions: 4" X 4.5"

Voltage: 10.8 V

Capacity: 3.0 Ah

Configuration: 4P3S (12 cells)



## Circuit Board in the Panasonic Thinkpad 760XD Lithium-ion Battery

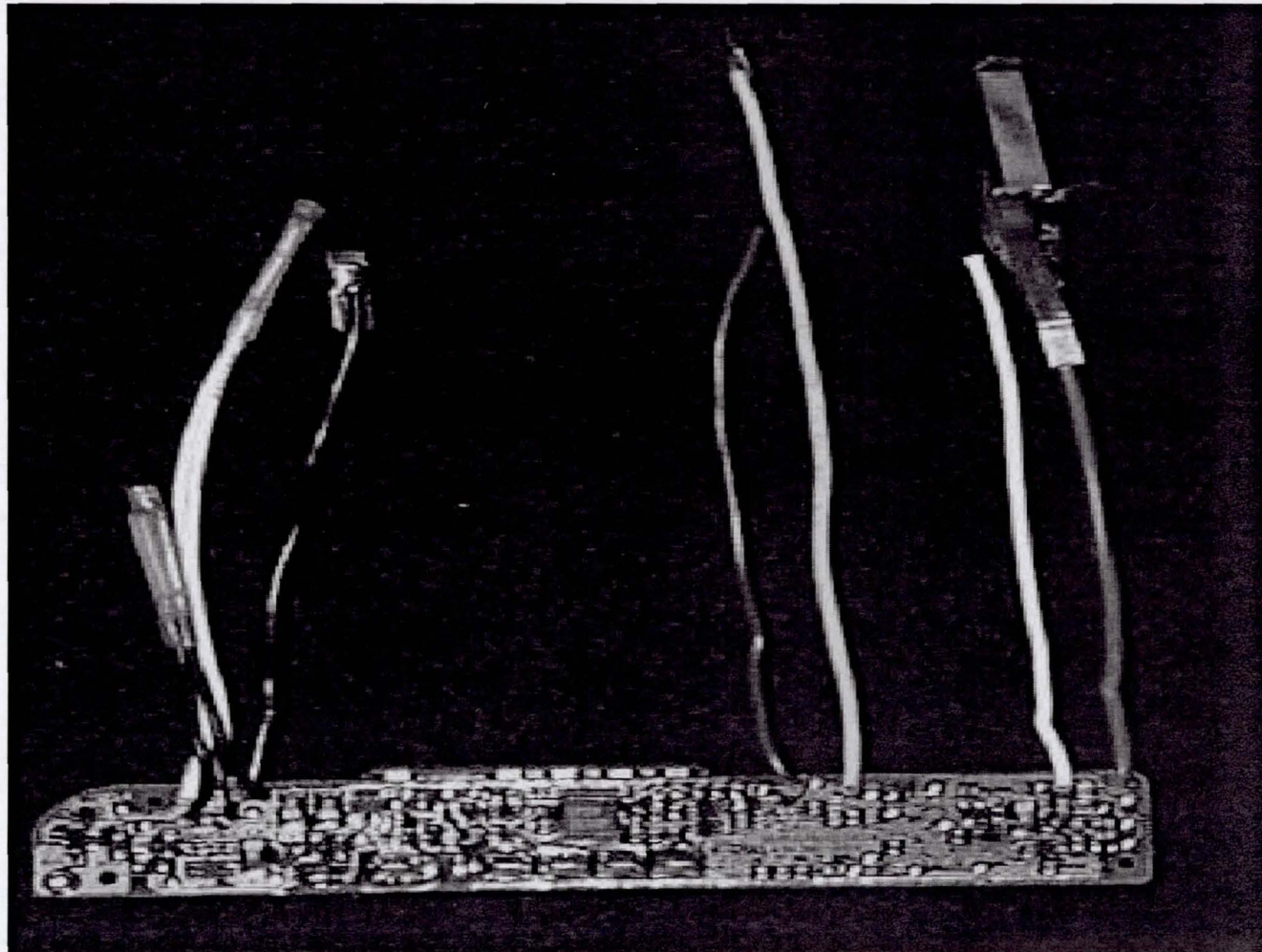



# Panasonic Lithium-ion Battery for the IBM Thinkpad A31P

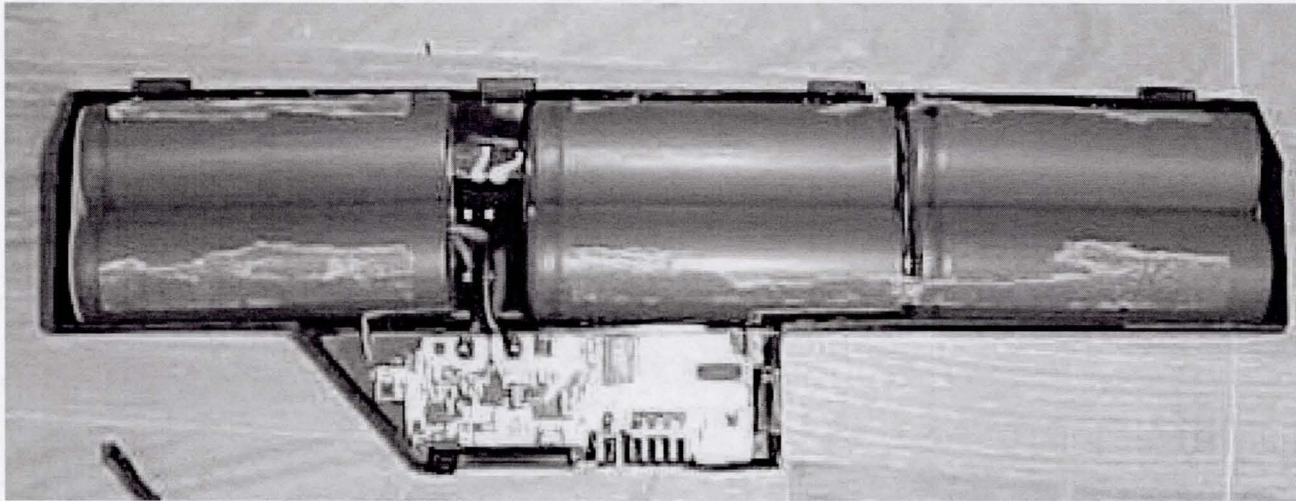



## Panasonic Li-ion Thinkpad (A31P) Characteristics

### Physical Characteristics:

Weight:  $318.1 \pm 1.0$  g

Height:  $24.9 \pm 0.3$  mm

Length:  $215.6 \pm 0.6$  mm

Thickness:  $40.6 \pm 1.2$  mm

### Electrochemical Characteristics:

OCV at full charge: 12.6 V

CCV: 10.51 V



# Circuit Board in the Panasonic Lithium-ion Battery for Thinkpad 760XD

- Decisions about turning off charge and discharge switches based on cell bank voltages and current are made by firmware in microcontroller.
- Protective circuit performs capacity gauge function.
- Protective circuit can balance cell bank states-of-charge by putting small (15 mA) discharge currents on individual cell banks.

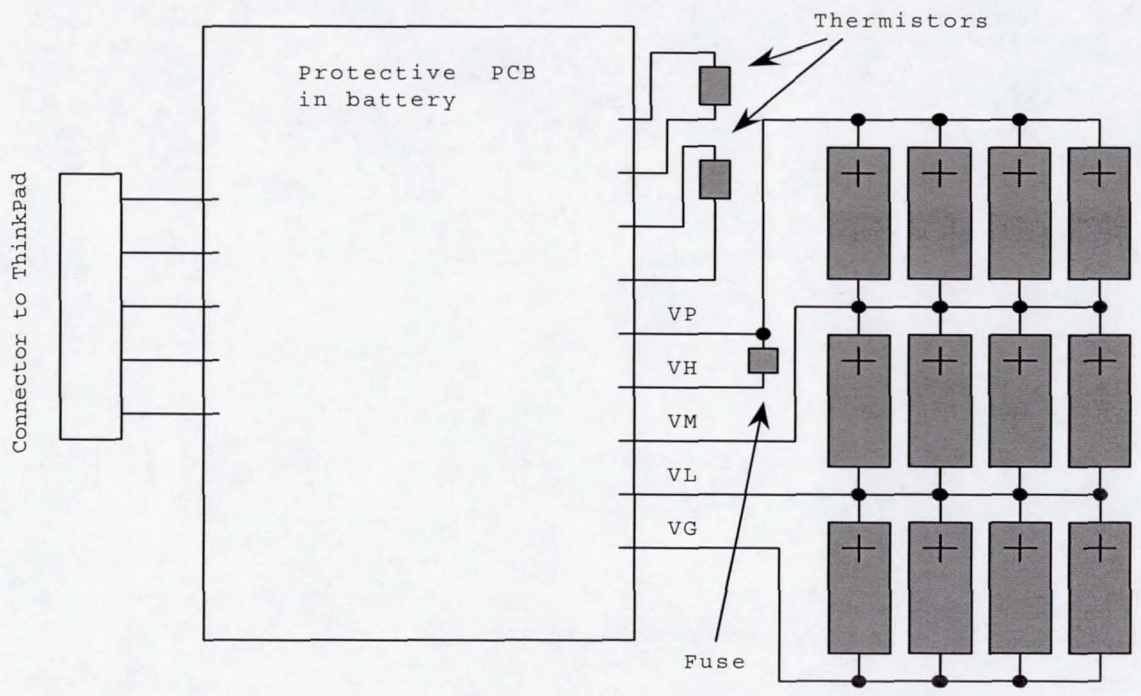

## Panasonic 17500 Lithium-ion Cells

### Physical Characteristics

**Weight:**  $24.43 \pm 0.6$  g

**Diameter:**  $16.399 \pm 0.4$  mm

**Length:**  $49.648 \pm 1.2$  mm

### Electrochemical Characteristics

**Open Circuit Voltage:** 3.9 V

**Capacity (room temperature):** 0.81 Ah



# Characteristics of the Panasonic 18650 cells for Thinkpad A31P

**Model No. CGR-B/663AT**

## **Physical Characteristics**

**Weight:**  $44.5 \pm 0.7$  g

**Diameter:**  $18.3 \pm 0.3$  mm

**Height:**  $64.6 \pm 0.5$  mm

## **Electrochemical Characteristics**

**Nominal Voltage:** 3.6 V

**Voltage at full charge:** 4.2 V

**CCV:** 3.75 V

**Capacity:** 2.0 Ah

# Typical Voltage and Current Profile During Charge of a Panasonic Lithium-ion Battery in the IBM Thinkpad

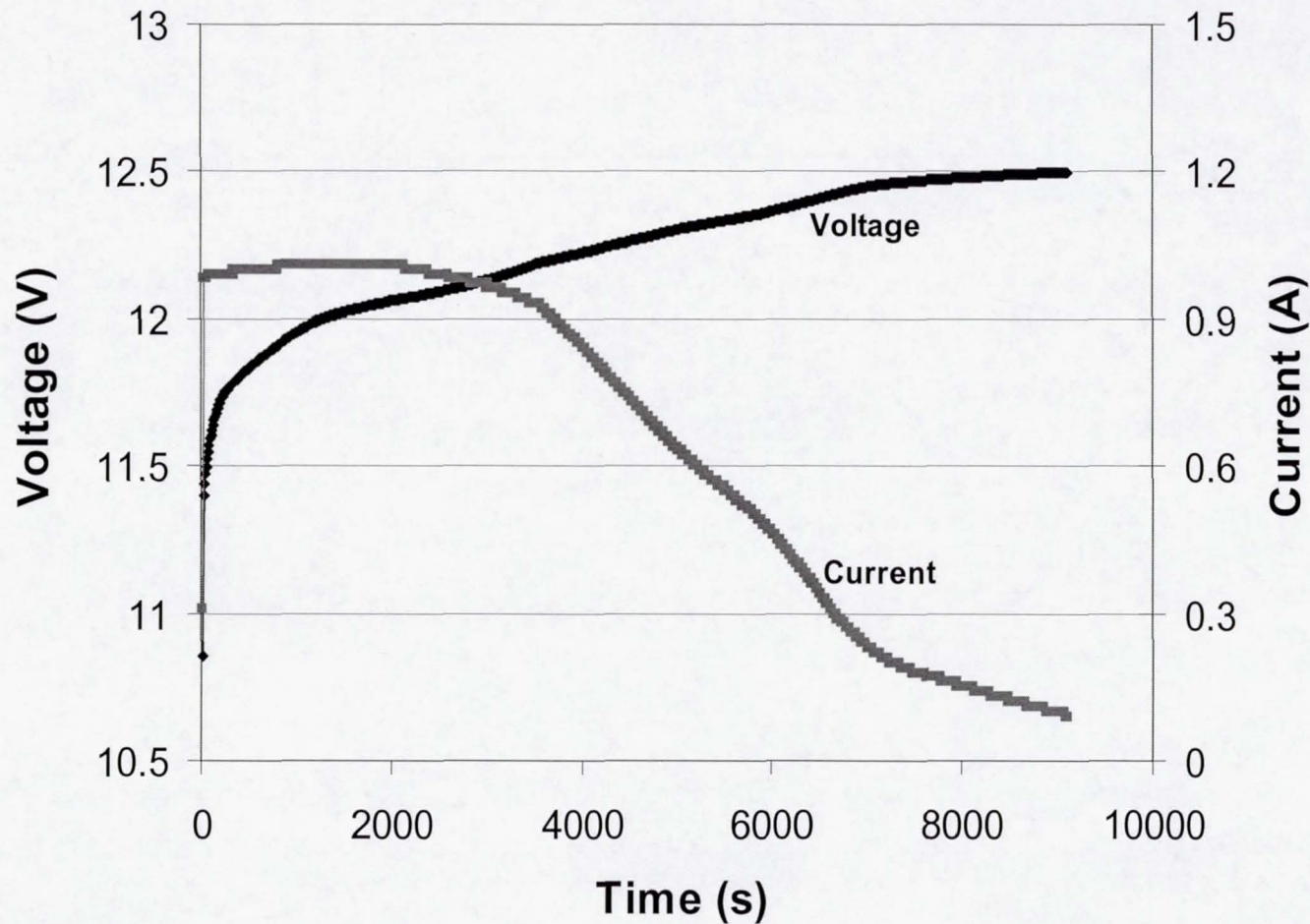



# Typical Discharge Profile for the Li-ion Battery in the Thinkpad A31P

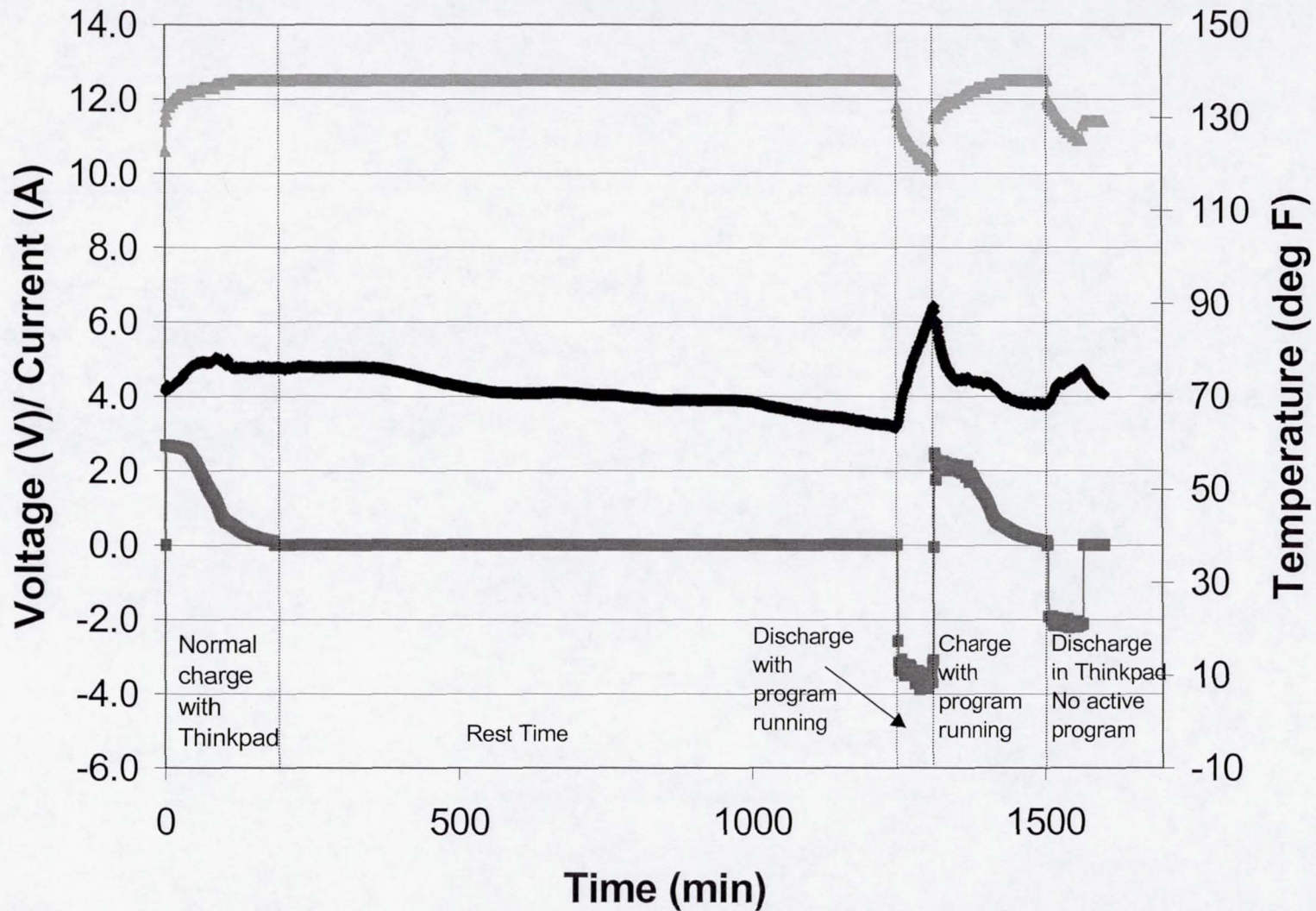

## Charge and Discharge of the Panasonic Lithium-ion Battery at Two Different Temperatures

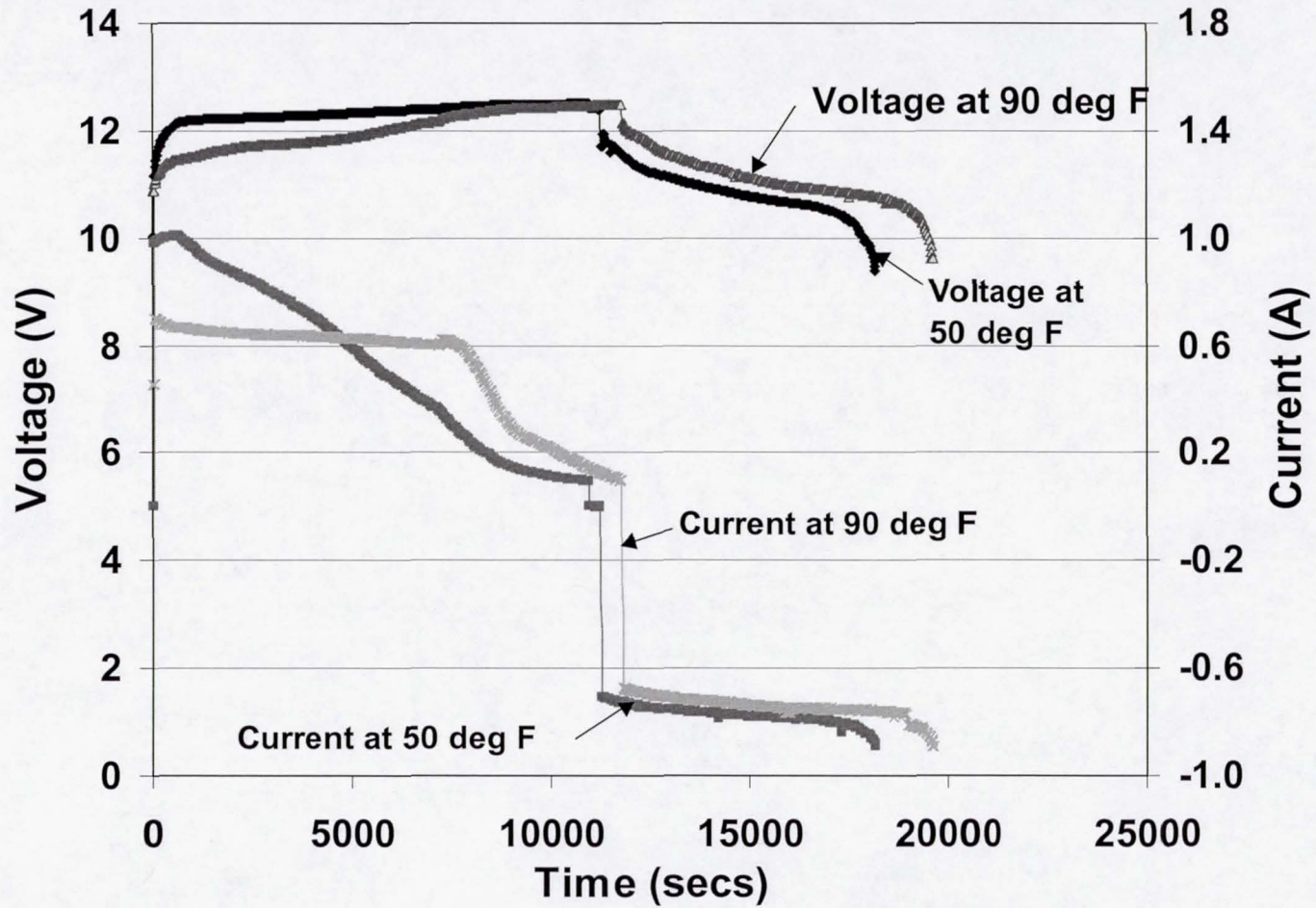



# Performance of the Panasonic Battery in the IBM Thinkpad A31P at 50 degrees F

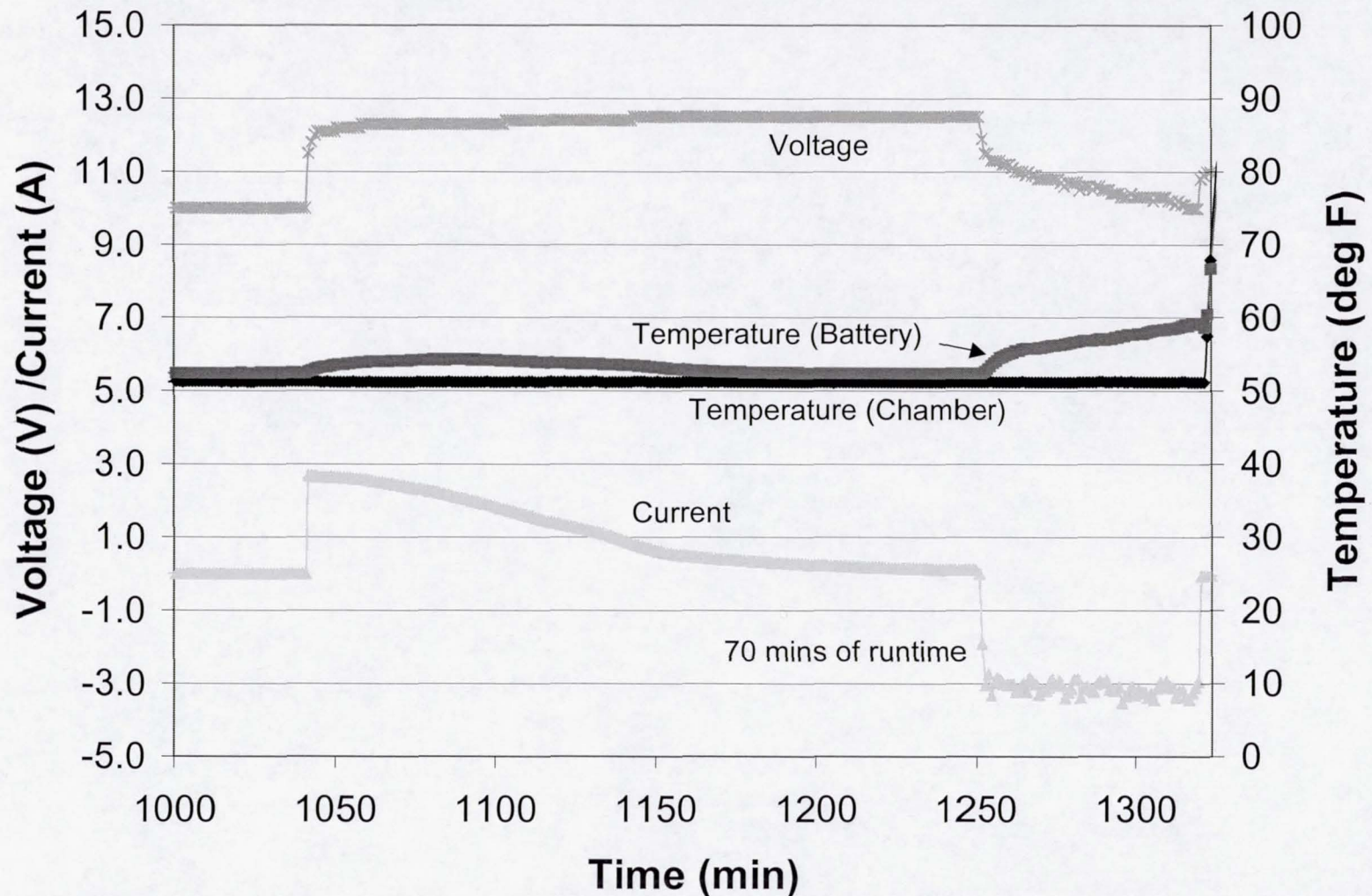



# Performance of the Panasonic Battery in the IBM Thinkpad A31P at 90 degrees F

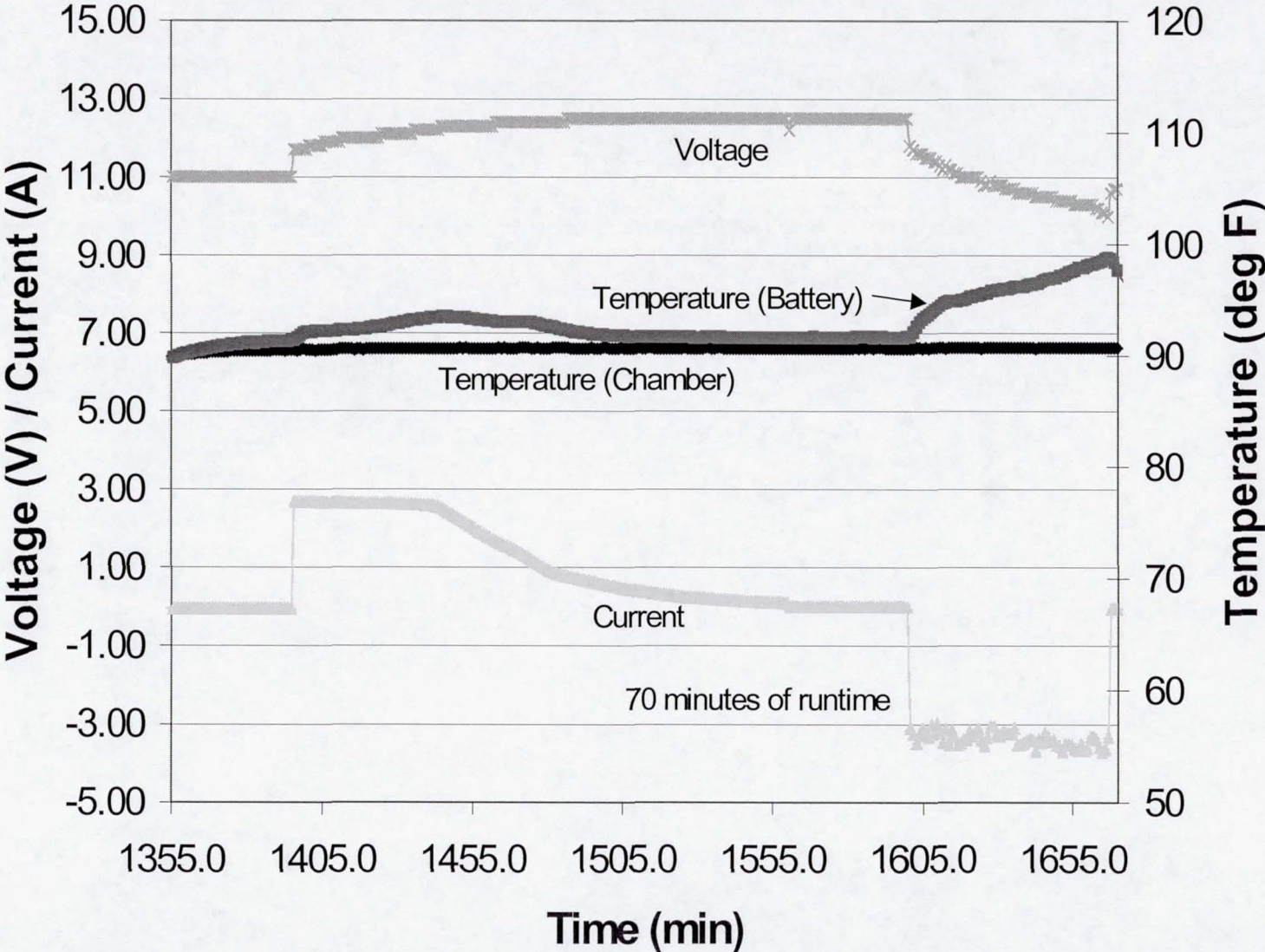



# Overcharge of the Panasonic Lithium-ion Battery for Thinkpad 760XD

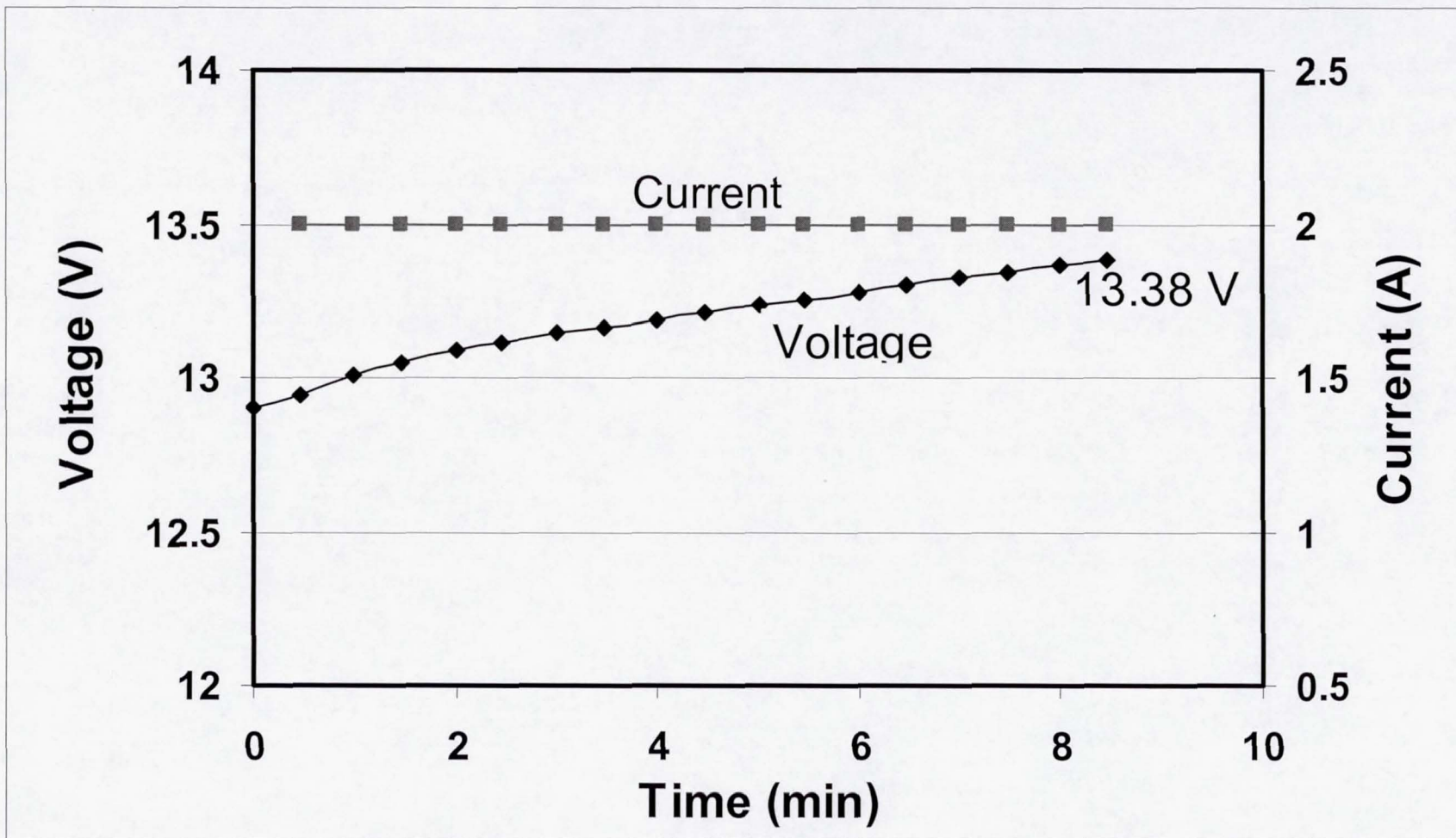

# Overcharge Test of Panasonic Battery in A31P Thinkpad

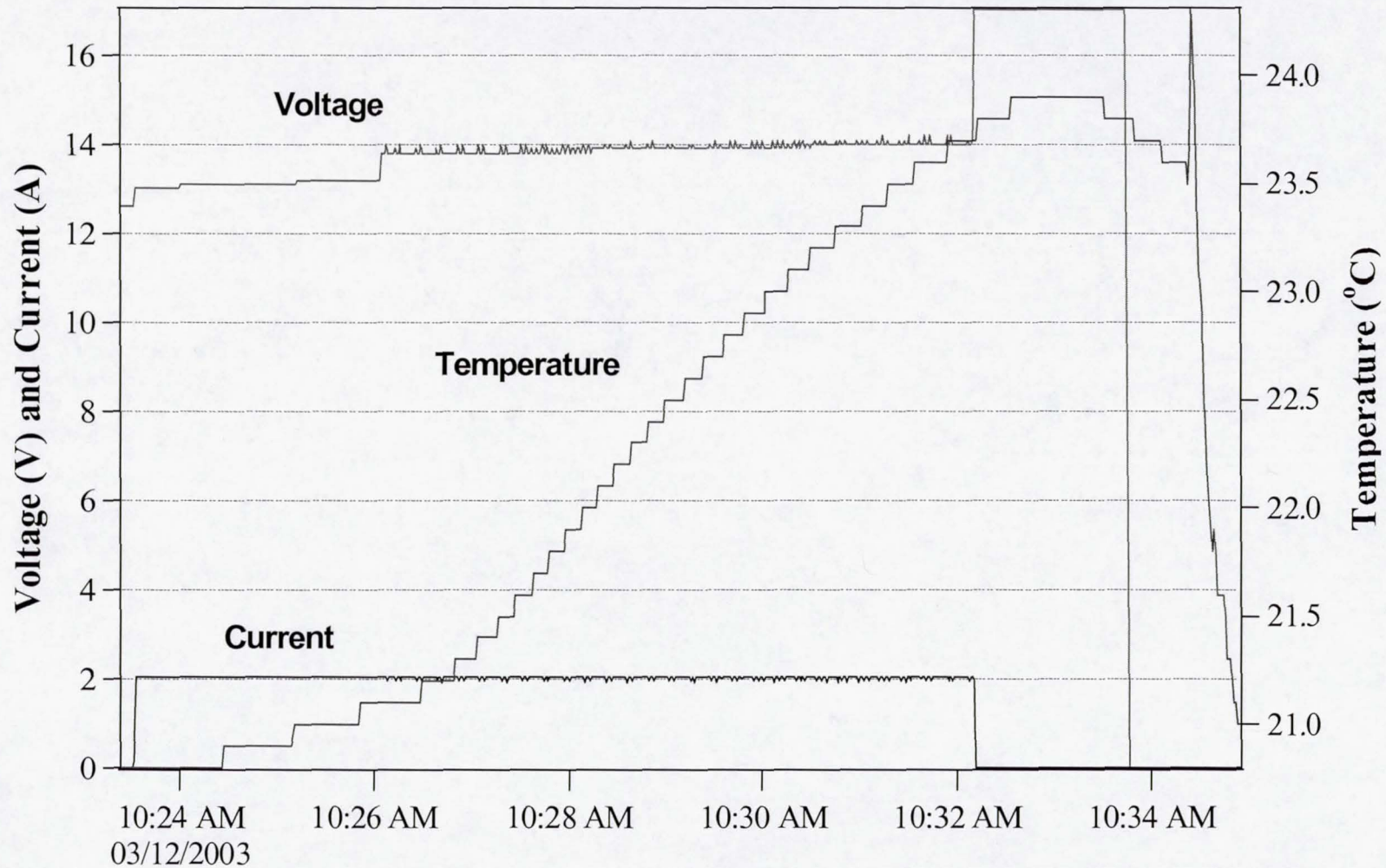



# Voltage Profile for the Individual Cell Banks During Overcharge of the Top Cell Bank for Thinkpad 760XD

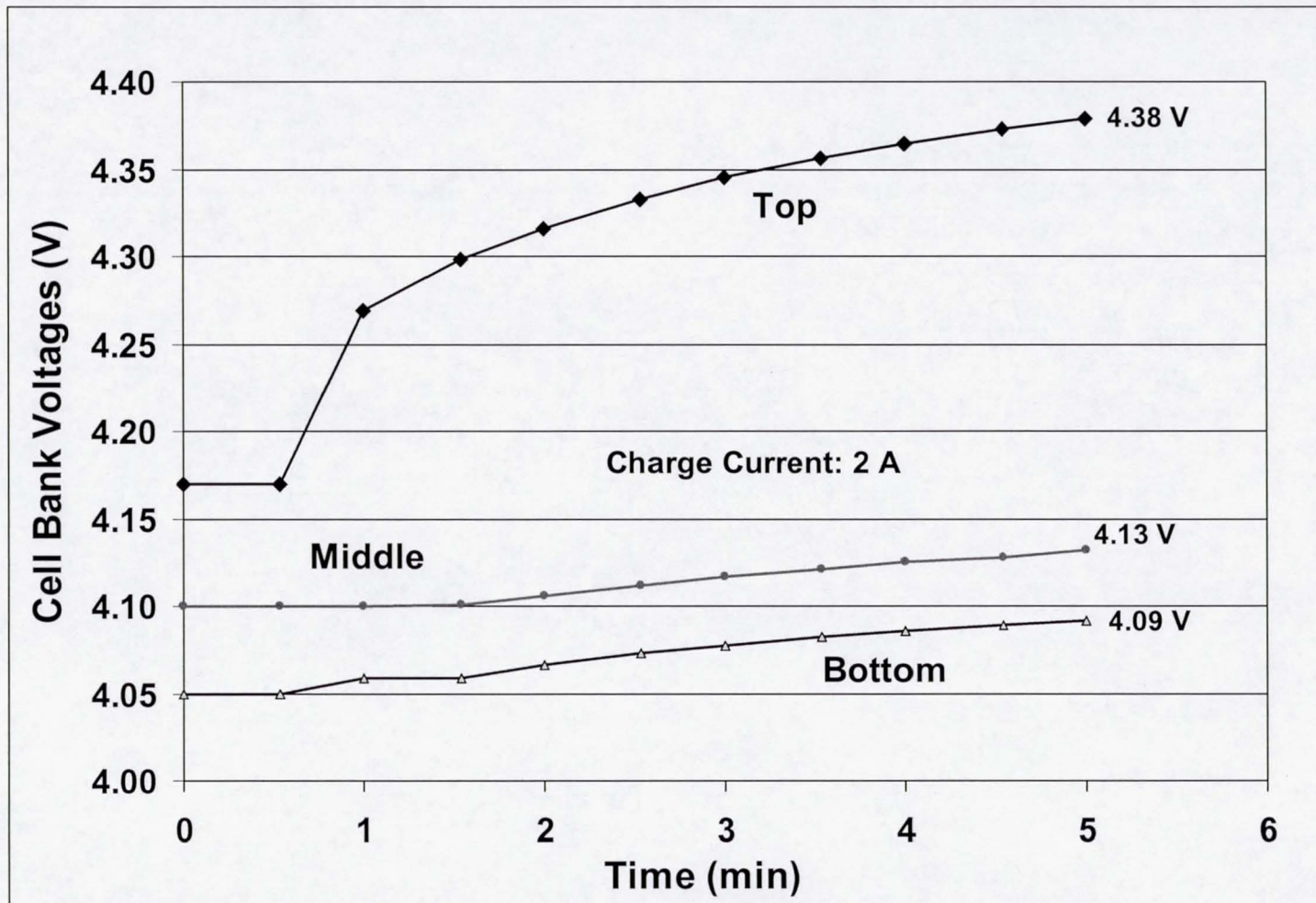

# Overcharge of Individual Cell Bank in the Thinkpad A31P Panasonic Battery

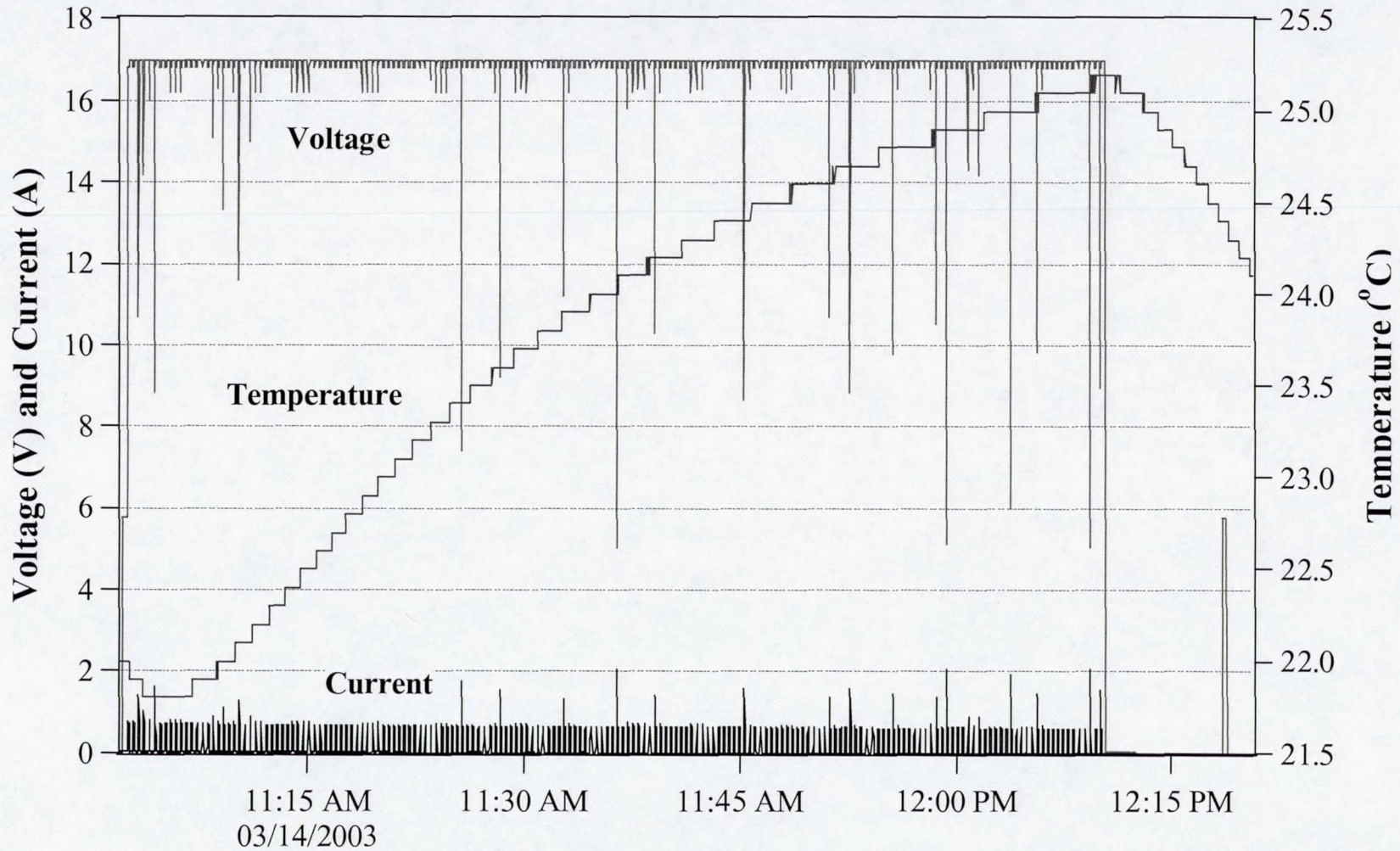



# Overdischarge of the Panasonic Lithium-ion Battery for Thinkpad 760XD

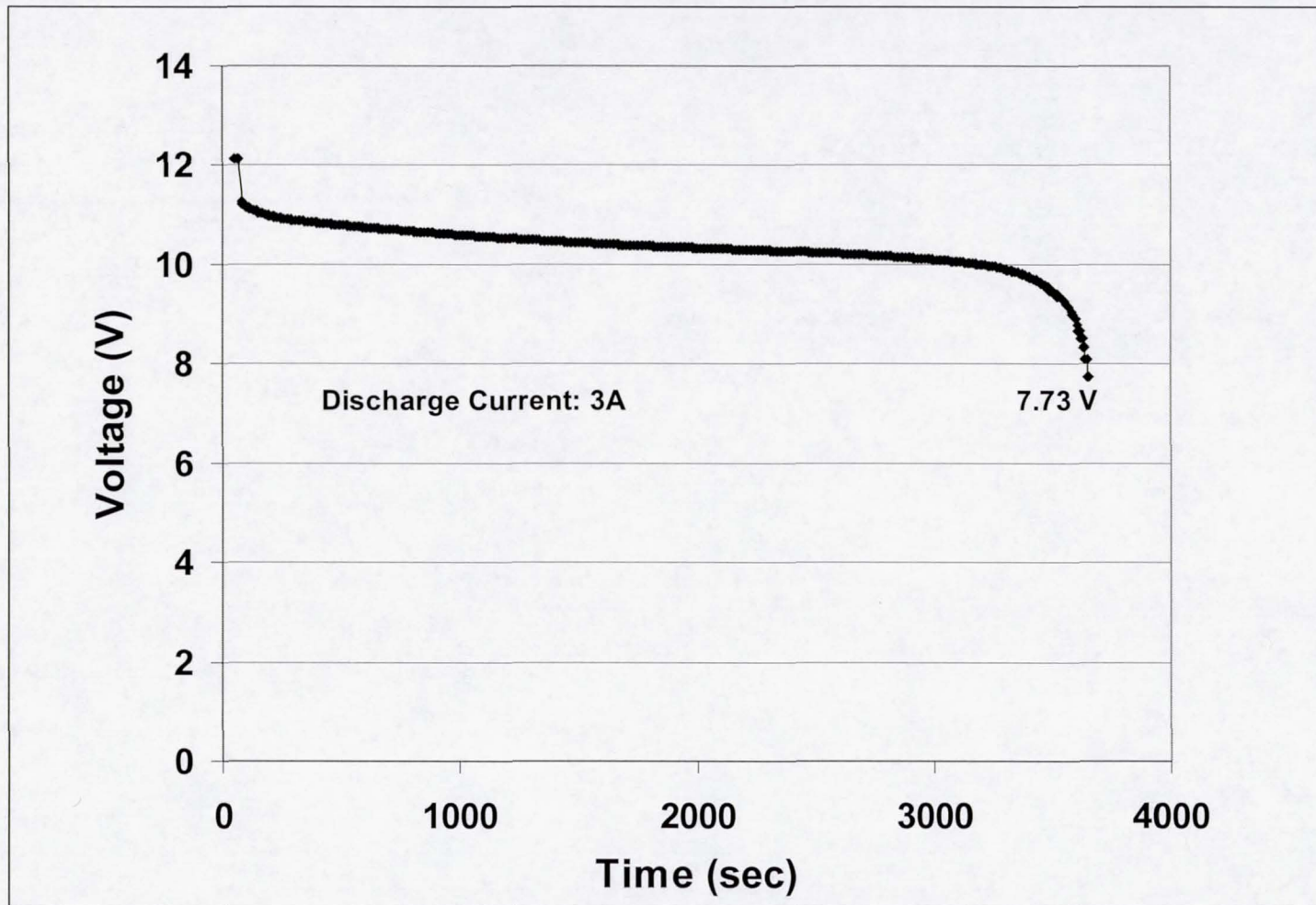

# Overdischarge of the Panasonic Lithium-ion Battery for the A31P Thinkpad

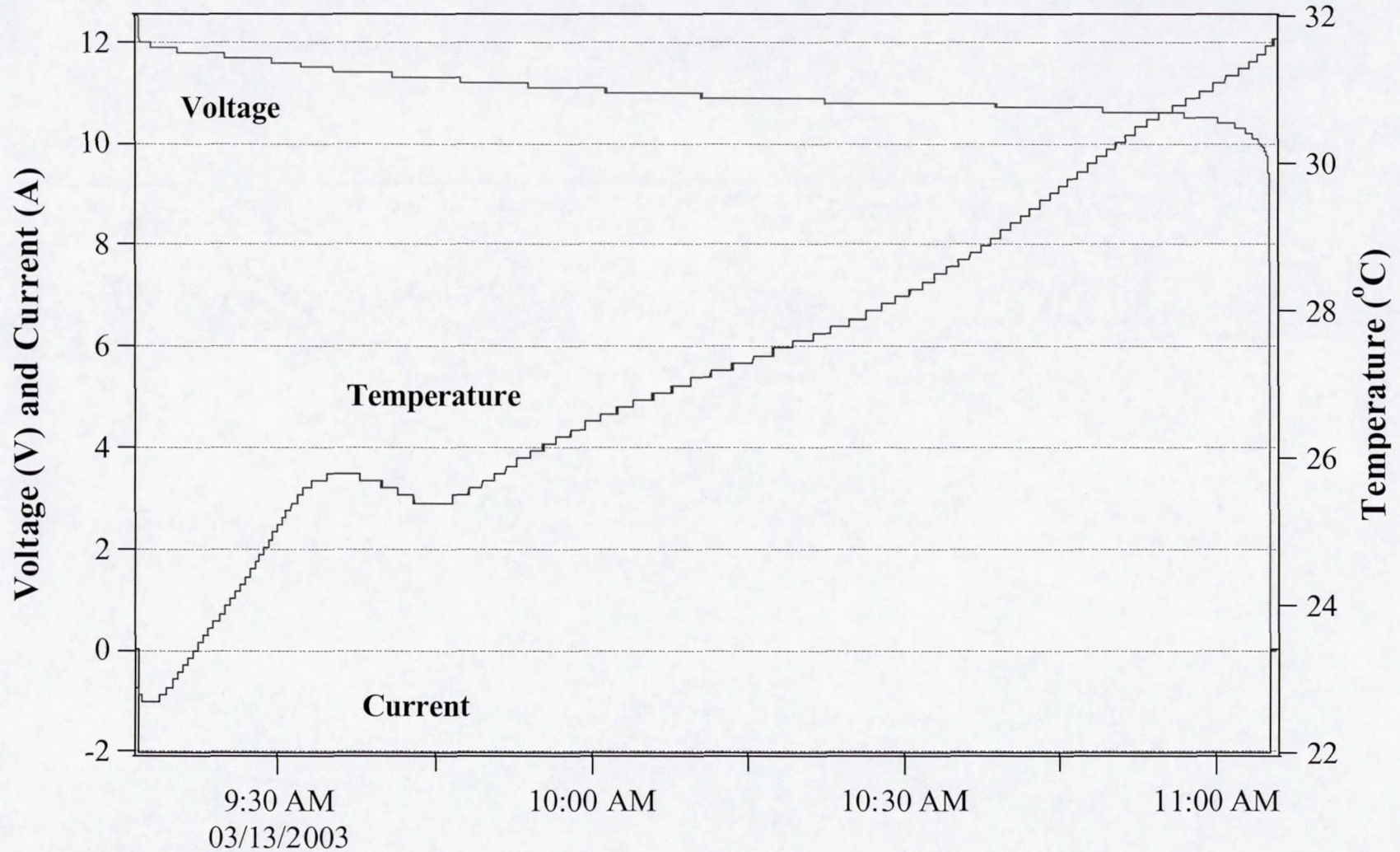



## Voltage Profile of Individual Cell Banks During Overdischarge of Top Cell Bank for Thinkpad 760XD

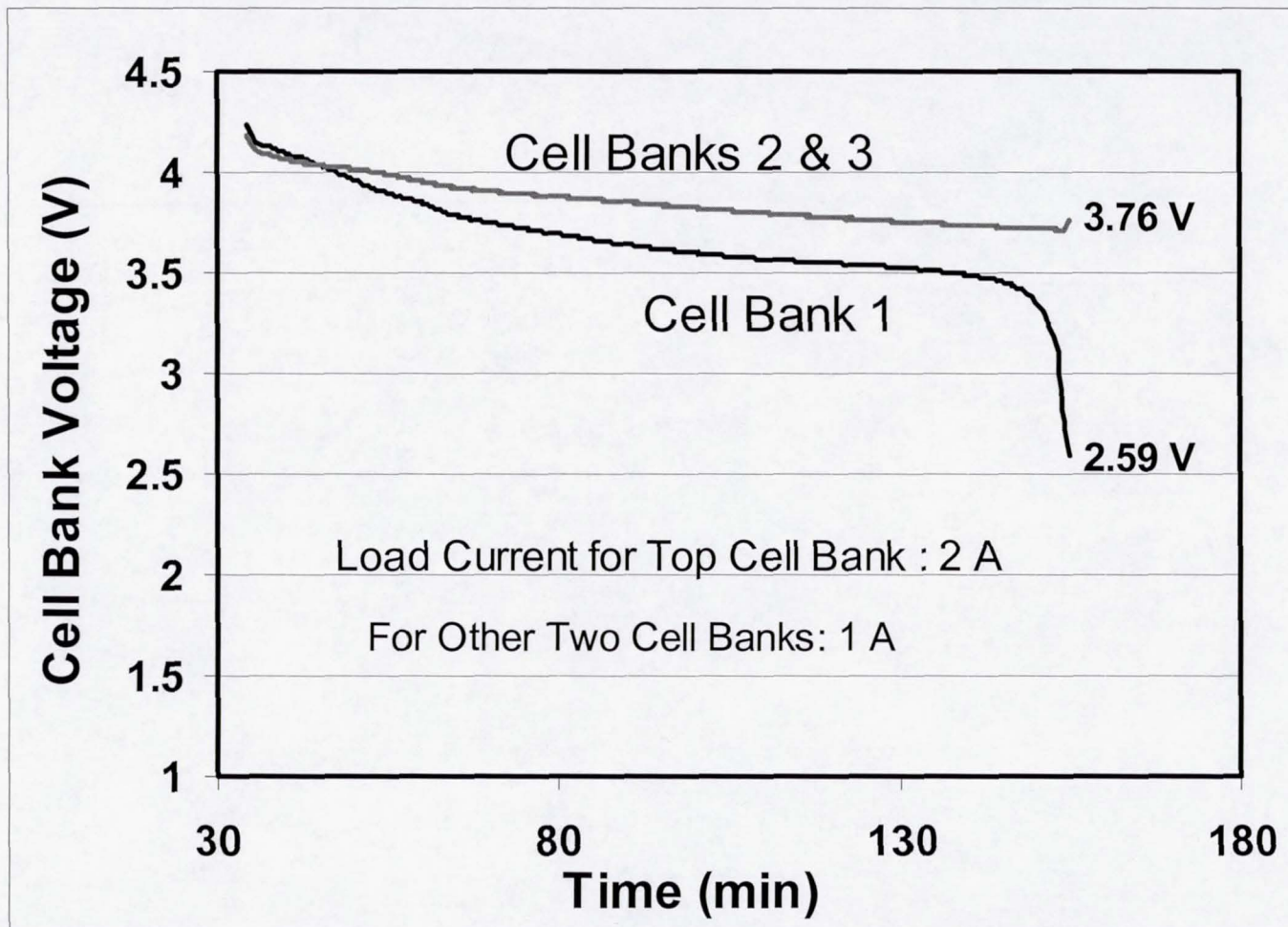

# Voltage Profile of Individual Cell Banks During Overdischarge of Top Cell Bank for Thinkpad A31P

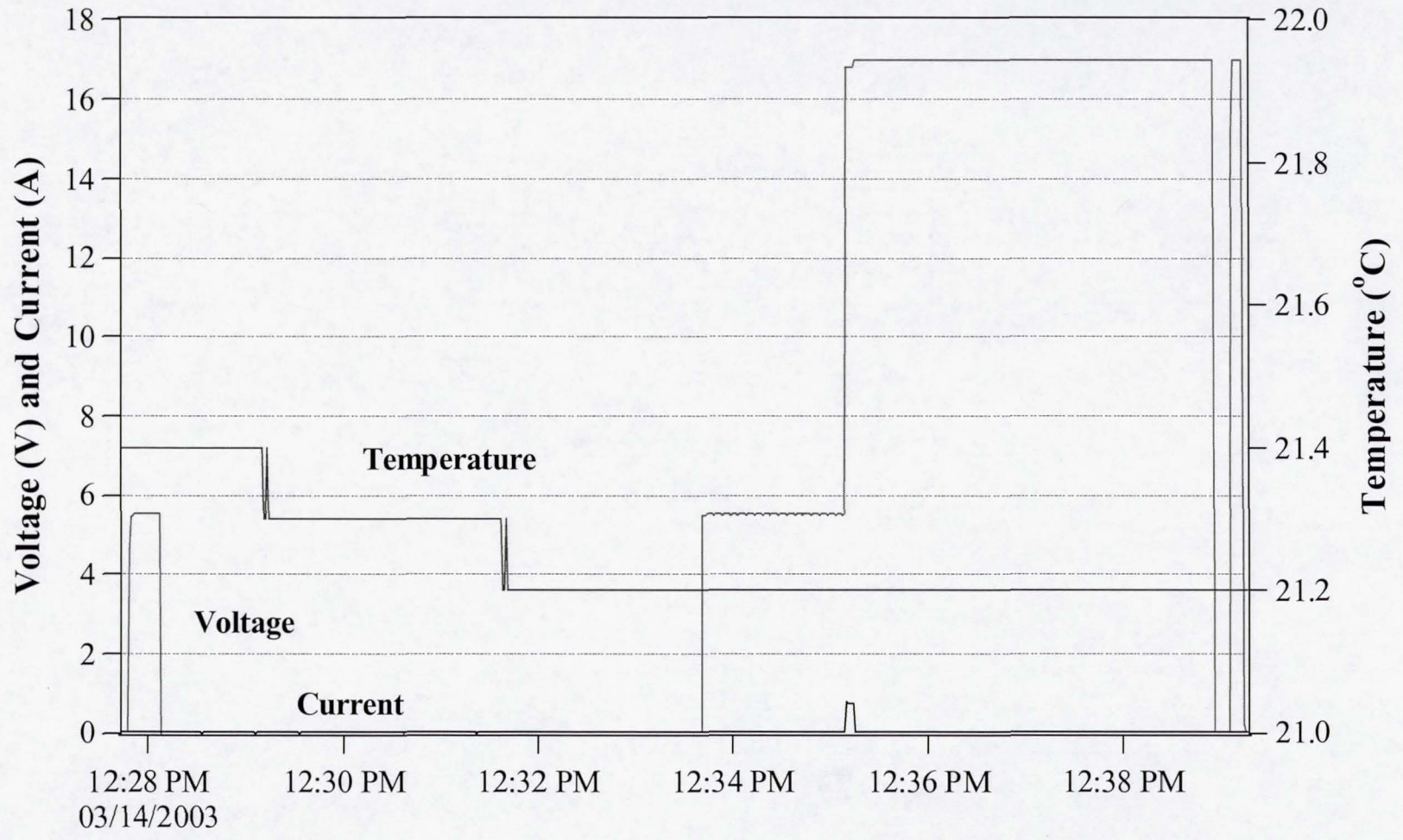

12:28 PM  
03/14/2003



## Circuit Board in the Panasonic Lithium-ion Battery for Thinkpad 760XD

- Decisions about turning off charge and discharge switches based on cell bank voltages and current are made by firmware in microcontroller.
- Protective circuit performs capacity gauge function.
- Protective circuit can balance cell bank states-of-charge by putting small (15 mA) discharge currents on individual cell banks.

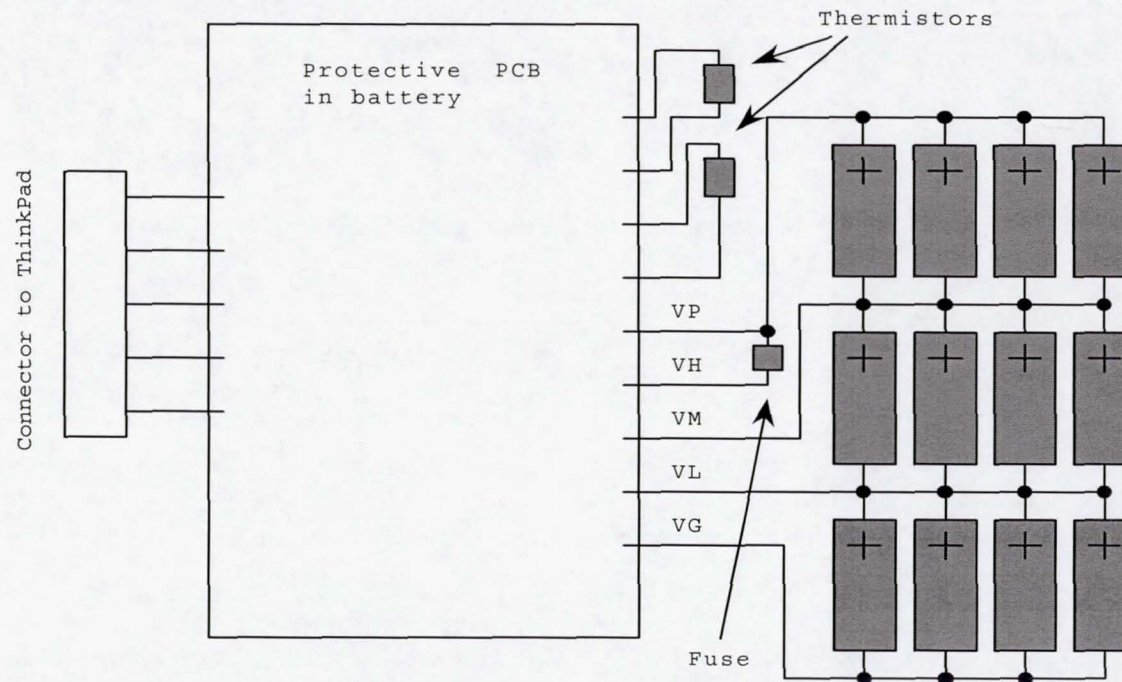

## Circuit Analysis for Thinkpad 760XD

- Failures were imposed on the parts of the circuit board and it was determined that there were no single point circuit element failures that would result in a hazardous condition.
- There is a single IC chip and two MOSFET switches. The two MOSFET switches are connected in series in the main current path. One controls charge current (at 13.38 V) and the other controls discharge current (at 7.7 V).
- There is a thermal fuse in series with the MOSFETs, which opens at 135 °C with no current and at 50 °C with a 4 A DC flowing through it.
- The thermal fuse is placed next to the MOSFETs, presumably to trip if they overheat.



## Circuit Analysis for Thinkpad A31P

- **Current limit:** Discharge currents  $>5A$  cause battery disconnect from load. Reset by connection to charger.
- **Undervoltage cutoff:** If any cell bank voltage drops below 2.5 volts, battery disconnects from load. Reset occurs when all cells are greater than 2.7 V or when connected to the charger.
- **Overvoltage cutoff:** Charger disconnected if any cell is  $>4.3$  volts. Reset occurs when all cells are less than 4.2 V or when connected to a load.
- **Cell temperature sensor (thermistor):** Analog temperature sensor in close proximity to cells. Charge cuts off if temperature  $> 50^{\circ}C$ . Resets when temperature falls.
- **Cell Thermal cutoff switch (thermostat):** Opens electrical connection to cells, preventing charge or discharge if temperature  $> 80^{\circ}C$ . Resets when temperature falls.

## Circuit Analysis for Panasonic Battery in Thinkpad A31P

- **MOSFET thermal cutoff:** Ceramic device thermally bonded to charge and discharge control MOSFETs. Opens like a fuse if temperature exceeds 120°C.
- **Self safing feature:** If any cell voltage  $> 4.3$  V, control circuit activates heater in MOSFET thermal cutoff device, permanently blowing it. This permanently disables the battery if it subject to extreme abuse.



## Vibration Test for the Panasonic Lithium-Ion Batteries for the Thinkpads 760XD and A31P

<u>Frequency</u>	<u>Level</u>
20-80 Hz	+3 dB/octave
80-350 Hz	0.1 g <sup>2</sup> /Hz
350-2000 Hz	-3 dB/octave

Both batteries were subjected to the above vibration levels and did not exhibit any significant changes in discharge capacity on post-vibration cycling. Less than 2% changes in capacity was observed in the 760XD batteries. The A31P batteries showed a 0.5 % increase in capacity.

## Vibration Test Fixture

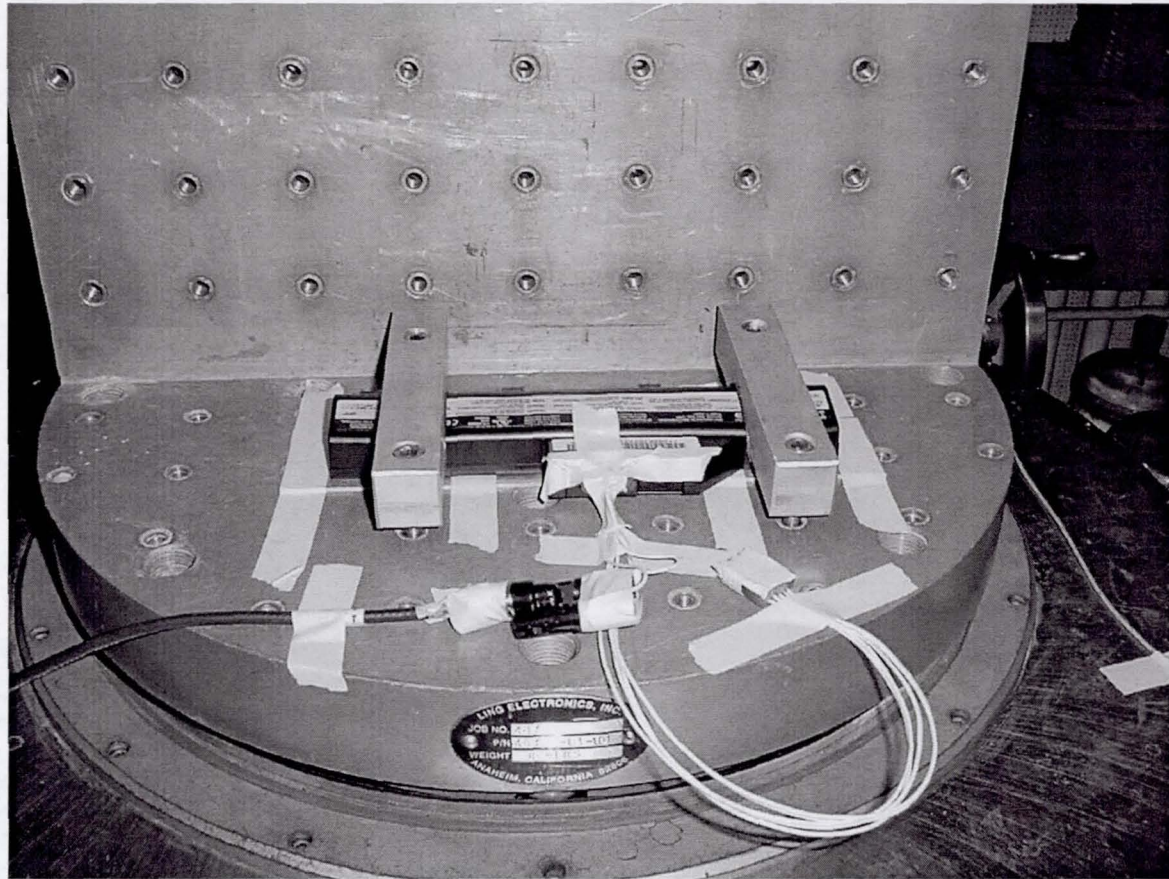

Battery: Z-axis



## CONCLUSIONS

- The Panasonic lithium-ion batteries for the Thinkpad 760XD and A31P were tested under normal and abuse conditions.
- The protective features in both batteries are different but they prevent the cells from going into any hazardous situations under abuse conditions.
- The cells and the battery have adequate protection under conditions of overcharge and overdischarge to prevent any catastrophic occurrences. Batteries have protection under unbalanced conditions.
- The failures imposed on the circuit boards proved that there would be no single element failures that would cause the cells to go into a hazardous condition.
- The new Panasonic lithium-ion battery for the Thinkpad A31P has been qualified for flight on the Space Shuttle and International Space Station.

## **ACKNOWLEDGMENT**

**Johny Rodriguez, Tony Parish, Randal Parish, Alan Barth -  
Lockheed Martin/NASA-JSC**