

An Effective Division of Labor between Human and Robotic Agents Performing a Cooperative Assembly Task

Fredrik Rehnmark¹, William Bluethmann², Jennifer Rochlis³, Eric Huber⁴, Robert Ambrose³

¹ Lockheed Martin Space Operations

frehnmar@ems.jsc.nasa.gov

² Hernandez Engineering

bluethmann@jsc.nasa.gov

³ NASA Johnson Space Center

jrochlis@ems.jsc.nasa.gov, Robert.Ambrose@jsc.nasa.gov

⁴ Metrica

eric@roboteyes.com

Abstract. NASA's Human Space Flight program depends heavily on spacewalks performed by human astronauts. These so-called extra-vehicular activities (EVAs) are risky, expensive and complex. Work is underway to develop a robotic astronaut's assistant that can help reduce human EVA time and workload by delivering human-like dexterous manipulation capabilities to any EVA worksite. An experiment is conducted to evaluate human-robot teaming strategies in the context of a simplified EVA assembly task in which Robonaut, a collaborative effort with the Defense Advanced Research Projects Agency (DARPA), an anthropomorphic robot works side-by-side with a human subject. Team performance is studied in an effort to identify the strengths and weaknesses of each teaming configuration and to recommend an appropriate division of labor. A shared control approach is developed to take advantage of the complementary strengths of the human teleoperator and robot, even in the presence of significant time delay.

1. Background

This section establishes proper context for the particular variety of human-robot teaming to be studied in this paper. It also explains the motivation behind the work in terms relevant to a wide audience.

1.1 The Role of Humans in Space

The International Space Station (ISS) is the largest and most complex space structure ever flown. Each phase of the ISS lifecycle, with the exception of final de-orbiting, depends heavily on human labor with activities ranging from the exotic to the mundane. The planned human workload, already well underway, calls for a significant amount of direct physical interaction with ISS hardware during assembly,

deployment, maintenance, research, and repair operations. Some of these are Intra-Vehicular Activity (IVA) operations taking place in the carefully controlled environment found in the ISS cabin. Others are Extra-Vehicular Activity (EVA) operations requiring trained crewmembers to don External Mobility Unit (EMU) spacesuits and exit the pressurized cabin through an airlock.

Should it require a spacewalk, even a seemingly trivial task instantly becomes both hazardous and complex. Accidents or malfunctions can quickly turn deadly in the vacuum of space, where sunlit surfaces can heat up to 100°C and shaded surfaces can plunge to -200°C. Strict procedures are practiced to ensure that a spacewalking astronaut is always secured with at least one lifeline in the event that the astronaut loses her/his grip while climbing and begins drifting away from the spacecraft. Flight hardware design requirements prohibit sharp edges and corners to avoid puncturing spacesuits. Background radiation levels can be orders of magnitude higher outside Earth's protective atmosphere and there is always the remote risk of a micrometeoroid/orbital debris (MMOD) impact. Because of the inherent risk and expense, EVA time is a precious resource used sparingly. Cost estimates range as high as \$100K per astronaut-hour of EVA time. Nevertheless, EVA operations are unavoidable, especially when critical equipment fails unexpectedly.

1.2 The Role of Robots in Space

Today's robotic explorers are pushing back the frontiers of the solar system and will soon extend our reach even beyond. Because they can accept high levels of risk, robotic space missions offer ever-expanding capabilities at decreasing cost. The highly successful Mars Pathfinder mission, for example, made observations and performed experiments on the Martian surface for a period of almost three months at a cost comparable to a single Space Shuttle flight (about \$250M).

Robots built to work in space have several advantages over their human counterparts. These machines can far exceed the physical capabilities of humans in limited roles demanding precision, strength and speed. They are not dependent on perishable consumables or pressurized cabins and can withstand extreme environmental effects including temperature and radiation. They may even be able to continue functioning at reduced capacity in the event of serious damage. Most importantly, robots are expendable machines that can be repaired or replaced when they fail.

1.3 Human-Robot Teaming in EVA Operations

When comparing humans and robots, it is only natural to differentiate between the types of work suited to each. But what happens when the work demands the complementary strengths of humans *and* robots? Such scenarios are common in the EVA world of precisely machined and mated components cluttered with umbilical cables, thermal blankets and storage bags. An EVA human-robot team combining the information-gathering and problem-solving skills of human astronauts with the

survivability and physical capabilities of space robots is proposed as a compromise designed to increase productivity.

Astronauts already use teleoperated robots, built by the Canadian Space Agency (CSA) to assist them in EVA operations. The Space Shuttle's robotic arm, or Shuttle Remote Manipulator System (SRMS), is used to capture and position large orbiting payloads or to retrieve them from the Shuttle cargo bay. The Space Station Remote Manipulator System (SSRMS), provides ISS crewmembers the ability to reconfigure the Station by moving functional modules from one docking port to another. These robots excel in instances where high strength, long reach, and coarse positioning capability are required. They are well suited to large-scale construction and deployment tasks. Maintenance work, in contrast, requires a much finer degree of control and greater dexterity than either arm can offer. To meet this need CSA has developed the two-armed Special Purpose Dexterous Manipulator (SPDM) to perform some very well-defined servicing work, like replacing failed Orbital Replacement Unit (ORU) modules in precisely located receptacles found on the outside of the ISS.

1.4 Introducing Robonaut

Recognizing the opportunity to augment human presence in space with cost-effective machines, the Automation, Robotics and Simulation Division (AR&SD) at NASA's Johnson Space Center (JSC) is developing, in collaboration with the Defense Advanced Research Projects Agency (DARPA), a humanoid robot called Robonaut (Figure 1). Unlike other space robots, Robonaut is designed specifically to work with and around humans. The robot's considerable mechanical dexterity allows it to use EVA tools and manipulate flexible materials much like a human astronaut would. About the same size as the EMU spacesuit, Robonaut can go wherever a suited astronaut can. By meeting these requirements, the Robonaut project leverages NASA's enormous investment in tools, procedures, and workspaces for spacewalking astronauts. Aboard the ISS, robotic astronauts like Robonaut could perform routine chores, assist humans in more complex tasks, and be available for emergency EVA operations in minutes, instead of hours.

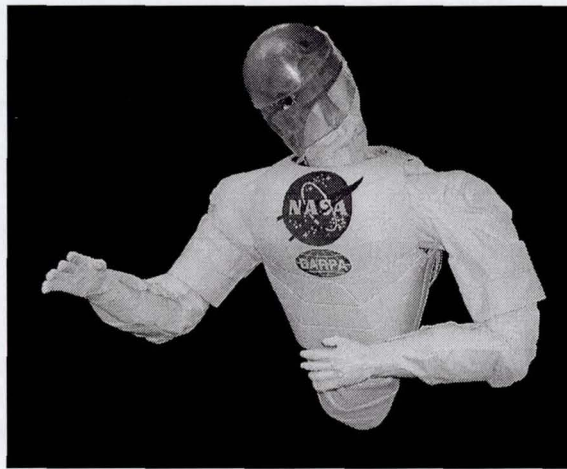

Fig. 1. Ground-based Robonaut system

2. Robonaut System Overview

This section provides an overview of the various elements making up the robotic system used in the cooperative assembly task trials.

2.1 System Morphology

The requirements for interacting with ISS crew members, interfaces and tools provided the starting point for the Robonaut design. Anatomically, the robot closely resembles the form of a suited EVA astronaut except that it has only one leg instead of two (Figure 2). Altogether, the planned free-flyer configuration will have at least 50 coordinated degrees-of-freedom (DOFs) and physical capabilities approaching those of a human in a spacesuit. A detailed discussion of subsystem anatomy may be found in [1].

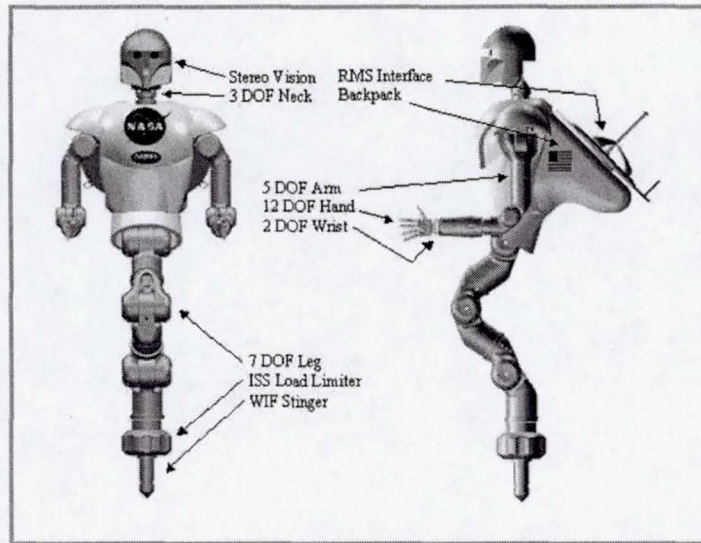

Fig. 2. Anatomy of Robonaut (free-flyer configuration)

Although the challenges of designing robots for space and terrestrial applications are very different, a ground-based Robonaut system was built at JSC to develop and test control strategies. On Earth, the robot is encumbered by gravity and does not have sufficient strength to stand on its single leg. For this reason, only the waist joints appear in the ground-based system. The focus, nevertheless, remains fixed on eventual orbital deployment, severely limiting the selection of materials, motors, and electronic components while posing unique thermal management problems.

2.2 Control System Architecture

Because Robonaut is a humanoid designed to work with and in near proximity to humans, the interface between the robot and the various humans in the system is central to the high-level control system design. Figure 3 shows the layout of the Robonaut control system architecture and highlights the possible human-robot interactions. Which agents and elements of the control system are active at any given time is task dependent.

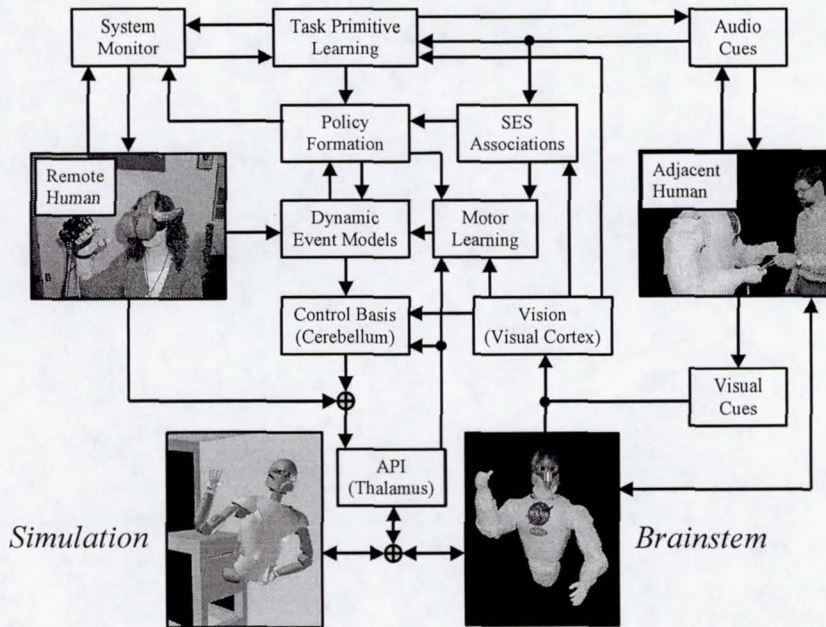

Fig. 3. High-level Robonaut control system architecture

The fundamental control methods for Robonaut are Cartesian position control of the arms and joint position control of the hands. A two-tiered force accommodation approach is used to handle external forces. For relatively small forces, Robonaut uses an impedance control law. In this control mode, the arm acts as a mass-spring-damper, complying to external forces, but returning to the original position if the load is relieved. For loads exceeding a user-defined threshold, the arm transitions into a damping control law, where the arm moves at a velocity proportional to the applied load. The two control modes are shown in relation to the rest of the Robonaut arm control laws in Figure 4.

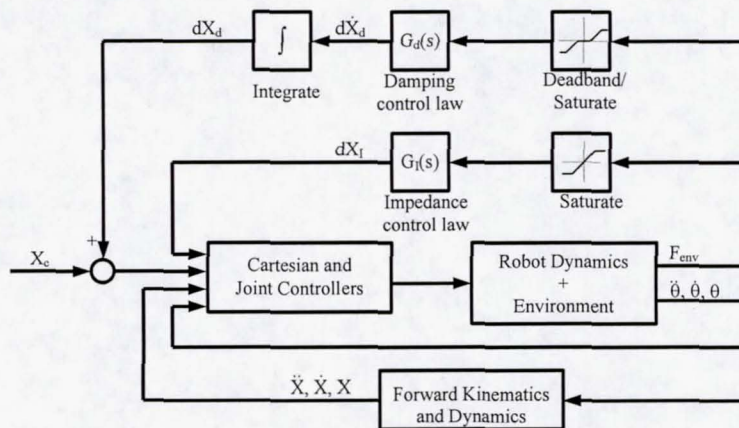

Fig. 4. Robonaut arm control system

While designed for safety, the force accommodation control laws can also be great tools for performing work. For example, when attempting to place a peg into a hole, the impedance control law may be stiff in the direction of insertion and compliant in the off-axes. This allows the manipulator to apply forces in the insertion direction without building up forces in the other axes. Damping control is effective in multi-agent tasks, where the robot follows a teammate's lead by moving to minimize loads.

2.3 System Capabilities

A wide array of tools and interfaces, both EVA and conventional, have been successfully handled in the course of testing the Robonaut system's capabilities [2]. Many of these have been utilized or manipulated to complete demonstration tasks of varying complexity. Some of the more interesting tasks are well beyond the capabilities of conventional robotic systems. One example is unzipping a backpack and searching through the contents.

3. Human-Robot Interfaces

The human-robot team used to perform the assembly task trials is depicted in Figure 5. Of the four team members, only two (Robonaut and the human co-worker) are actually present at the assembly worksite. Each member of the team can communicate with any other team member by exchanging information signals. Humans exchanging information with Robonaut interact with human-robot interfaces consisting of input devices and displays. These interfaces enable communication by encoding/decoding information into an intelligible form. In addition, the collocated task agents (Robonaut and the human co-worker) can interact by exchanging power signals such as force, touch, and vibration. These types of physical interactions are distinguished from those reproduced by an appropriate interface, such as a force-feedback joystick, because of signal degradation issues. Such an interface is called a teleoperation interface.

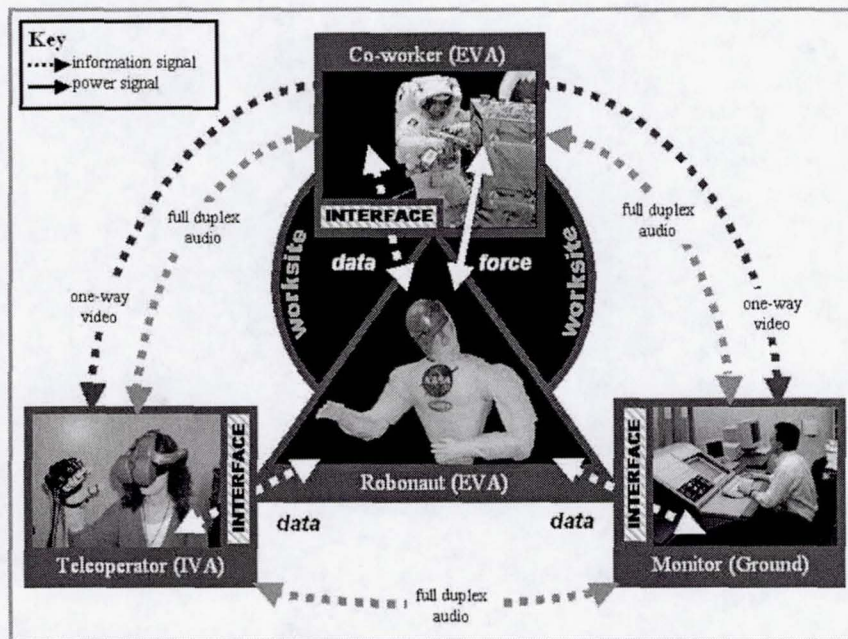

Fig. 5. Information and energy exchange in a typical human-robot team

3.1 The Teleoperator's Interface

In its simplest form, Robonaut is a teleoperated master-slave system in which a human, the "teleoperator," becomes the robot master. The anthropomorphic form of the robot allows an intuitive, one-to-one mapping between master and slave motions. The teleoperation interface used in the assembly task trials is shown in Figure 6. To enhance the operator's sense of immersion (telepresence), additional feedback may be provided in the form of visual aids and kinesthetic, tactile, and auditory cues. Williams [3] showed that the addition of visual and kinesthetic feedback improved the performance of teleoperators working a specific task with the Robonaut system. Care must be taken, however, to ensure that the operator's workload in processing all of the new information does not become excessive [4].



Fig. 6. The teleoperation interface used in the assembly task trials

For all its utility in the laboratory, a teleoperated system degrades quickly in the presence of communication time delay. A human teleoperator can deal with a few seconds of time delay by slowing down her/his motions, effectively compressing the effect, or by adopting a move-and-wait strategy, thereby allowing the feedback to catch up [5], but these techniques are only useful for non-contact tasks or when interacting with a very compliant environment. Significant time delays are expected when communicating with space robots and, depending on the magnitude, varying degrees of autonomy are required to deal with them.

3.2 Interacting With and Through Robonaut

Humans interact with Robonaut in one of three roles including teleoperator, monitor, and co-worker. This interaction takes different forms depending on the configuration of the human-robot team and the degree of autonomy exercised by the robot. While the remotely located teleoperator and monitor exchange mainly information signals with the system, the co-worker is actually present at the worksite and can interact with the robot in a direct, physical manner. Robonaut is equipped with force and tactile sensors to sense these physical stimuli as well as motors to act upon them. When a human co-worker is present at the worksite, the teleoperator has the opportunity to interact indirectly with the co-worker through the robot, which may be considered an extension of the teleoperator's own body. From the co-worker's point of view, interacting with a teleoperated Robonaut is much like interacting with the teleoperator.

4. Cooperative Assembly Task Trials

A simplified, hypothetical EVA assembly task featuring human-robot teaming is simulated with hardware-in-the-loop to study the human-robot interaction problem.

4.1 Description of the Task

The task is purposely designed to require more than two hands and, therefore, multiple agents so that meaningful interactions can take place. A long structural beam, too awkward for one agent to handle alone, is to be inserted into a fixed socket and pinned in place.

Assembly Hardware. Three components are assembled together in this task (see Figure 7). There is a fixed socket, a lightweight 12 ft (3.7 m) structural beam, and a mating pin that locks them together. The socket is mounted on a six-axis force/torque sensor measuring the contact forces/torques between the beam and the socket. These forces/torques are resolved about a coordinate frame centered at the beam-socket interface and oriented as shown in the figure.

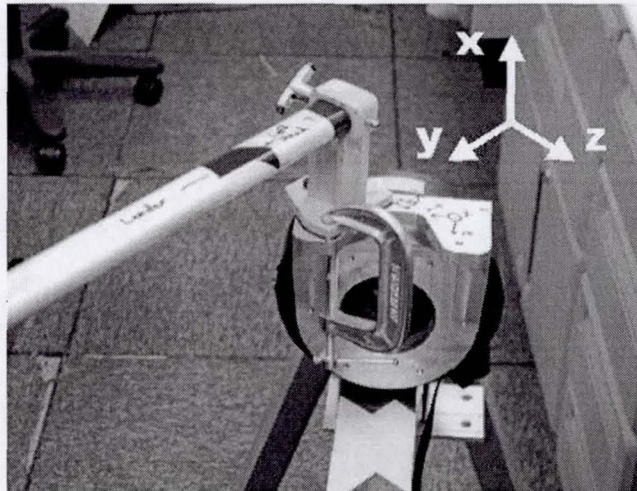

Fig. 7. Hardware used in the assembly task trials, force sensor axes shown

Assembly Sequence. The task begins with both agents, robot and co-worker, situated at the worksite. One agent, the leader (EV1 in NASA terminology), is near the fixed socket and the other agent, the follower (EV2), is located 10 ft (3.1 m) from the socket. Both agents start the task within arm's reach of the beam, which is initially supported at both ends. Initial conditions are controlled to reproduce the worksite between each trial and for each teaming configuration. The complete assembly sequence is laid out in Table 1.

Table 1. The assembly task trial sequence

Step	Leader (EV1)	Follower (EV2)
1. Initial Condition	at worksite near mating end of beam and socket	at worksite near free end of beam
2. Task Initiation	give signal to begin task	standby for signal
3. Acquire Beam	grasp beam with TWO hands	grasp beam with ONE hand
4. Position Beam	guide mating end of beam close to socket	support free end of beam; comply with commands/forces
5. Align Beam	align beam with socket	support free end of beam; comply with commands/forces
6. Insert Beam	insert mating end of beam into socket until it stops; mating holes in beam and socket should be aligned	support free end of beam; comply with commands/forces
7. Release Beam	release beam with both hands	support free end of beam; comply with commands/forces
8. Acquire Pin	grasp mating pin	support free end of beam; comply with commands/forces
9. Insert Pin	insert mating pin in nearest mating hole	support free end of beam; comply with commands/forces
10. Task Completion	push mating pin through mating holes; adjust beam alignment as necessary	support free end of beam; comply with commands/forces

Description of the Human-Robot Team. The assembly team consists of one robot and three humans. One human, the co-worker, is collocated with the robot at the worksite while the other two, the teleoperator and monitor, are in different remote locations. For this experiment, all four participants perform their roles in the same room but interaction is artificially limited as dictated by the target task.

Several constraints are imposed on the human co-worker in order to preserve the EVA relevance of the task. Spacewalking astronauts have a very limited field-of-view restricted to the window in the EMU helmet, which does not swivel with neck motions. In general, two astronauts working side-by-side on an EVA cannot see each other (Figure 8). They are unable to communicate through body language or gestures and cannot anticipate each other's actions through observation. By necessity, EV1 and EV2 communicate almost exclusively by radio, employing very methodical

handshaking to confirm mutual understanding. To minimize unrealistic interactions, an opaque curtain was hung between the agents during the task trials (see Figure 8). The agents were, however, allowed to communicate verbally.

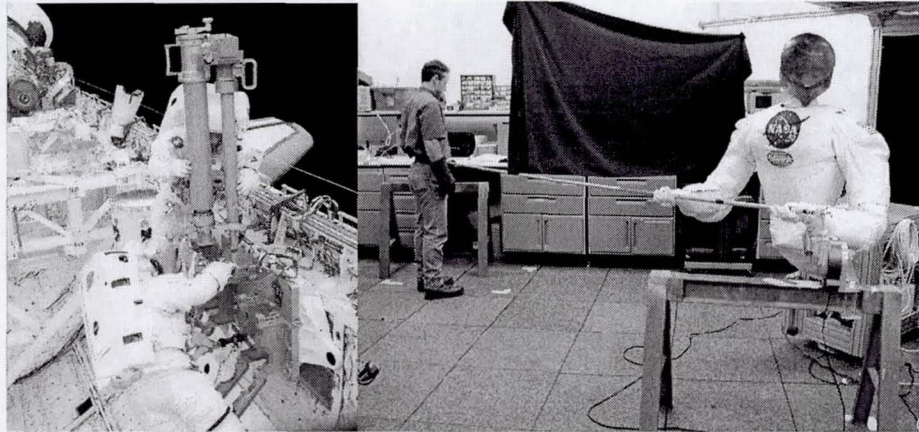

Fig. 8. Comparison of actual and simulated working conditions

The EMU encumbers the body motions of an EVA worker. Spacewalking astronauts have a restricted working envelope dictated by the EMU range of motion. The human co-worker in our task was instructed to remain stationary from the waist down during the task to prevent unrealistic physical feats. The EMU glove also degrades the tactile sensing of the wearer. The human co-worker was required to perform the task wearing heavy welder's gloves to simulate this effect.

4.2 Methodology

Two subjects, both experienced Robonaut teleoperators, participated in the experiment over the course of two days. Task trials were distributed across three experiment periods to reduce effects due to human subject fatigue. 8 possible teaming scenarios were identified based on combinations of role, subject and degree of automation (Tables 2, 3). For each of the 8 teams, the task was conducted 3 times for a total of 24 total trials. To reduce the effects of learning, a practice run was conducted between team reconfigurations to familiarize the subjects with their new role in the experiment.

Table 2. Team definition elements

Subjects	Roles	Automation
H ₁ = human subject 1	L = task leader (EV1)	M = manual, no automation
H ₂ = human subject 2	F = task follower (EV2)	T = teleoperation
		S = shared control

For task trials where Robonaut was involved, the major differences between teleoperation and shared control were the active force control settings described in Section 2.2. When Robonaut was the follower and teleoperated (H_xFT), the force control law was set up with damping control disabled and impedance control enabled but very stiff. In this case, the assumption was that the motions were gross and the teleoperator could control the gross motions.

With Robonaut as the follower running under shared control (H_xFS), the force control law was set up with damping control enabled, with the system well damped in the direction of insertion, lightly damped in other directions and impedance control disabled. This allows the leader to easily maneuver the robot in off-axes, but forces the leader to be meticulous in the insertion axis. For each of these trials (Teams 4 and 6), the teleoperator initially grasped the beam and lifted it slightly off the rest. Then control of the arm and hand was relinquished by issuing a voice command.

When Robonaut was the leader and teleoperated (H_xLT), the force control law was set up with damping control disabled and impedance control enabled, compliant in the off-axes and relatively stiff in the direction of insertion. In this case, the teleoperator performs fine motions and requires some assistance from the force controller.

Data Collection. The following data were recorded during each trial: videotape of the task leader, robot wrist forces/torques, socket contact forces/torques, elapsed time, and voice communication between the two subjects. Although task time was recorded, subjects were not instructed to perform the task rapidly. Human subjects were asked to turn in comments at the end of each experiment period. A final questionnaire was distributed to each human subject at the end of the experiment.

4.3 Performance Metrics

Performance metrics for the assembly task include task success, task completion time, maximum contact force/torque, and cumulative linear/angular impulse. Task success describes the degree to which a team was able to meet all task objectives. Task completion time reflects how efficiently resources were used in accomplishing the task. Maximum contact force/torque quantifies the risk of hardware failure or damage due to excessive momentary peak loads at the beam-socket interface. Cumulative linear/angular impulse quantifies the risk of hardware failure or damage due to excessive wear and tear as a result of extended contact at the beam-socket interface [3].

4.4 Results

Objective Results. Experimental results are presented in the Appendix in Table 3 and Figures 9 through 15. The first and most important measure of team performance is whether the task could be successfully completed at all. Teams 1 through 6 accomplished all 10 steps of the task successfully. The leader of Team 7, however, failed to insert the mating pin because the limited video resolution of the helmet-mounted display (HMD) prevented him from seeing the mating hole. As a result, Teams 7 and 8 required the test conductor's assistance in handling the mating pin (steps 8 through 10) but were still able to align the mating holes so the pin would go through. The task completion times shown for Teams 7 and 8 are artificially low. Pin insertion, however, does not require much force or torque so the maximum contact force and torque is still representative of the team's performance.

The most effective teams accomplished the entire task in a short amount of time with low contact forces/torques and low cumulative linear/angular impulses. In this case, "short" and "low" are relative terms defined by the benchmark performance of the humans-only Teams 1 and 2. In Figures 9 through 11, each of these metrics is normalized with respect to the average of all trials performed by Teams 1 and 2. The data shows that maximum contact forces (overall average = 48.0 N) were comparable across all team configurations with no discernable trend (see Figure 9). Task completion times, on the other hand, increased monotonically over the course of the experiment as the robot's role increased from nonparticipant to task follower to task leader (see Figure 11). The longest team average task completion times exceeded the benchmark time by factors of 8.9 and 6.6. Maximum contact torques (overall average = 5.49 Nm) fell somewhere in between, exceeding the benchmark by factors of 3.67 and 3.40. Representative contact force/torque data is presented in Figures 12 and 13.

Because cumulative linear/angular impulse (CLI, CAI) and verbal communication event count (VCEC) are all strongly correlated to task completion time ($r = .87, .96, .81$ respectively), the longer completion times indicate greater difficulty in performing the task. That is, the longer duration trials tended to require more communication between the human subjects and resulted in greater wear-and-tear on the hardware. Since these are the same trials featuring an increased robot workload, the correlation can be used as a starting point to identify candidate tasks suitable for human-robot teaming.

A word of caution: these experimental results should not be interpreted as a ranking metric or score that will, by itself, lead to the selection of the best human-robot team for the task. For one thing, human agents will always outperform robots in tasks designed for humans. Even if a weighting function combining all the performance metrics were constructed, there would still be other, equally important considerations like cost and risk. For example, the teleoperated robot-led trials (Teams 7 and 8) were the least impressive from a performance standpoint but they hold the potential for a new team consisting entirely of robots. That is, if robots can fill both the leader and follower role, the task may be performed in locations completely inaccessible to humans.

Subjective Results. With the exception of some first-trial outliers such as Team 2, Trial 1 and Team 6, Trial 1 (possibly due either to human subject unfamiliarity or simply suboptimal performance), the team groupings are reasonably coherent (see Figures 14, 15). They suggest that there is most room for improvement in Teams 7 and 8, in which the teleoperated robot acted as task leader. Both subjects commented that degraded visual feedback and lack of force feedback hampered their role as task leader in these teams. They rated the H_xLT role "Very Difficult" and "Average Difficulty." They did not, however, list the same complaints about either of the robot follower roles in Teams 3, 4, 5, and 6. They rated the H_xFT role "Average Difficulty" and "Somewhat Easy" and the H_xFS role "Average Difficulty" and "Somewhat Easy." Taken together, the data and comments indicate that the human-robot interface used in the experiment is useful for simple tasks but could be improved to enable more complex tasks.

In each new teaming configuration, the human subjects were exposed to new interface and task elements. These elements motivated a range of interaction strategies ranging from verbal position indexing commands in an improvised reference frame ("up/down", "towards/away from me") to kinesthetic communication via forces and torques passed through the beam. One of the most interesting innovations occurred during the teleoperated leader trials (Teams 7 and 8) when the leader, deprived of force feedback, asked the follower to report forces during the contact phase of the task. This proved to be an effective strategy in correcting a misaligned insertion.

Both human subjects reported that increased verbal communication helped them accomplish the task, both as leader and follower. As team leader, one human subject reported the difficulty of translating the beam in the "soft" directions and the ease of translating it in the "stiff" direction using only force (Teams 4 and 6). This is due to the mechanical advantage enjoyed by the follower, who is at the other end of a long moment arm.

5. Conclusions

Four different team configurations were tried in this experiment. As the robot played a progressively greater role and the humans suffered more sensory deprivation, task completion time increased monotonically but maximum contact force remained constant. In each case, the team leader recognized that the task was harder, slowed the working pace, and treated the hardware more gently. The leader was not, however, as effective at controlling contact torque, which is dominated by the follower. These slower trials were also characterized by increased verbal communication as the human subjects shared task-relevant information in both directions.

Due to interface issues, the teams led by a teleoperated robot required assistance in completing the task. A different team with better performance (robotic follower under shared control) can tolerate significant time delay because the teleoperated portion of the task, grasping the beam, does not require contact with a stiff environment. This team shows promise for working effectively in the target space environment.

This experiment highlights the necessity of good verbal communication between team members in challenging work environments, especially when those environments limit other types of sensory feedback. The capability to learn and issue improvised commands is a critical teaming skill, which no team member, robotic or otherwise, should be without.

6. Future work

Interaction forces/torques between the agents were measured but not extensively analyzed in this experiment. For one thing, no benchmark data was available because only trials involving the robot had any wrist torque/force data. A force/torque sensor installed in-line in the center of the beam would provide a way to benchmark and measure these interactions.

A framework has been laid for future human-robot interaction experiments. A higher fidelity simulation of EVA working conditions, including suited human subjects, realistic lighting conditions and time delay, is needed before teaming approaches can be evaluated in the proper context.

Different team configurations required different modes of communication and interaction between the agents. Elements of these should be mixed and tested to identify new ways of enabling intuitive human-robot interaction. One interesting possibility involves combining verbal position indexing commands to make angular adjustments in the "soft" alignment directions and force commands to translate in the "stiff" insertion direction. This dual strategy was, in fact, used extensively by the human subjects in the human-only task trials (Teams 1 and 2).

The human-robot team should be expanded to include a mix of robotic agents of different classes. One such team might include an astronaut, an RMS, a Robonaut, and a free-flying camera such as Aercam. Teaming configurations with no humans in them should also be studied.

References

1. Ambrose, Robert O., Aldridge, H., Askew, R. S., Burrige, R., Bluethmann, W., Diftler, M.A., Lovchik, C., Magruder, D. and Rehnmark, F., "ROBONAUT: NASA's Space Humanoid", IEEE Intelligent Systems Journal, August 2000.
2. Ambrose, R.O., Culbert, C., and Rehnmark, F., "An Experimental Investigation of Dexterous Robots working with EVA Hardware", AIAA Space 2001, Albuquerque, NM, August 2001.
3. Williams, L. (2001). *Bisensory Force Feedback in Telerobotics*. Unpublished doctoral dissertation, University of Houston.
4. Rochlis, J. L. (2002). Human Factors and Telerobotics: Tools and Approaches for Designing Remote Robotic Workstation Displays. *Aeronautics and Astronautics*. Cambridge, MA, Massachusetts Institute of Technology: 139.
5. Ferrell, W. R. (1965). Remote manipulation with transmission delay. *IEEE Transactions on Human Factors in Electronics HFE-6* (1).

Appendix

Table 3. Assembly task trial results

Teaming Configuration	Trial No.	Task Completion Time (sec)	Max Force (N)	Max Torque (Nm)	CLI ¹ (Ns)	CAI ² (Nms)	VCEC ³
1. H ₁ LM, H ₂ FM	1	28.4	35.5	2.23	133.2	11.22	10
	2	13.5	44.2	4.17	135.8	7.19	3
	3	13.2	43.1	3.61	130.8	6.38	4
2. H ₂ LM, H ₁ FM	1	20.4	71.1	6.18	245.2	25.25	6
	2	17.7	17.9	0.50	40.7	2.43	6
	3	18.3	14.0	0.17	34.6	1.96	6
3. H ₁ LM, H ₂ FT	1	45.5	39.3	2.40	265.6	19.69	12
	2	23.7	80.4	4.76	202.9	11.04	7
	3	34.2	72.2	5.38	370.6	24.10	11
4. H ₁ LM, H ₂ FS	1	45.6	60.6	11.80	234.1	20.04	5
	2	37.6	56.7	9.35	217.6	17.48	4
	3	53.2	60.2	9.77	221.0	23.22	4
5. H ₂ LM, H ₁ FT	1	44.0	37.9	5.14	109.7	17.18	12
	2	44.6	25.4	1.08	52.3	2.68	15
	3	46.8	14.9	0.57	40.5	1.37	14
6. H ₂ LM, H ₁ FS	1	116.0	99.7	23.34	432.7	93.05	5
	2	85.1	47.8	1.73	85.4	4.92	5
	3	60.9	28.4	3.55	103.0	8.79	4
7. H ₁ LT, H ₂ FM	1	179.3	57.0	11.88	873.1	66.73	26
	2	184.5	59.4	12.09	938.4	102.26	31
	3	134.3	27.6	0.76	385.3	6.81	21
8. H ₂ LT, H ₁ FM	1	142.8	60.4	5.8	1601.1	76.96	22
	2	129.4	60.8	4.38	612.2	27.42	18
	3	97.6	37.1	1.11	294.5	7.71	13

1. CLI = Cumulative Linear Impulse at beam-socket interface $\sum_{t_i}^{t_f} |\vec{F}(t)| \Delta t$

2. CAI = Cumulative Angular Impulse at beam-socket interface $\sum_{t_i}^{t_f} |\vec{M}(t)| \Delta t$

3. VCEC = Verbal Communication Event Count, approximate (both human subjects)

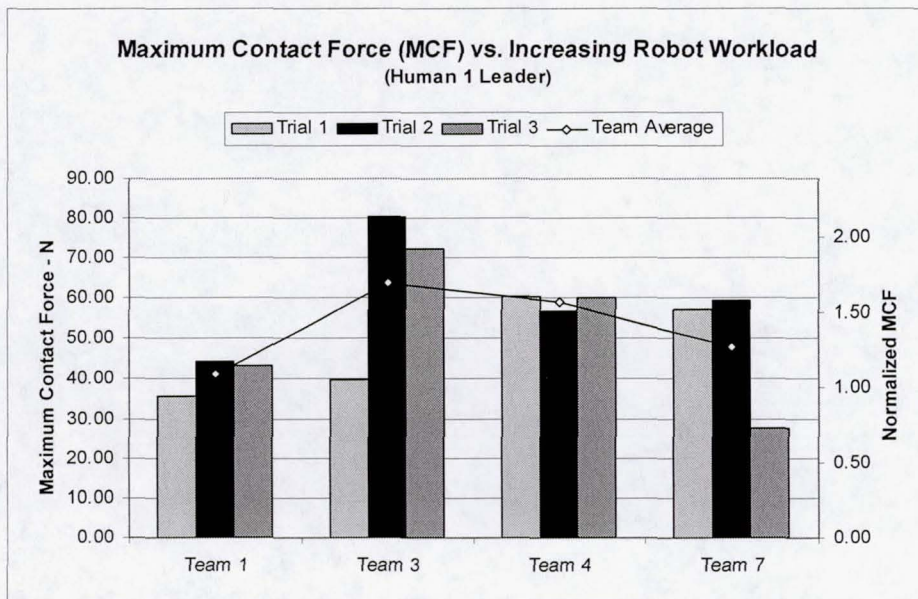

Fig. 9. Maximum Contact Force vs. Increasing Robot Workload (Human 1 Leader)

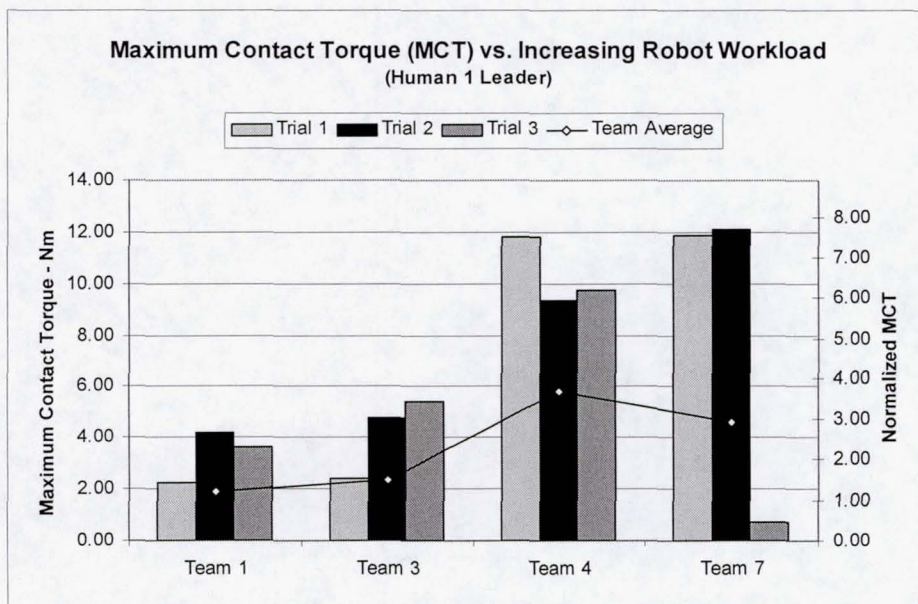

Fig. 10. Maximum Contact Torque vs. Increasing Robot Workload (Human 1 Leader)

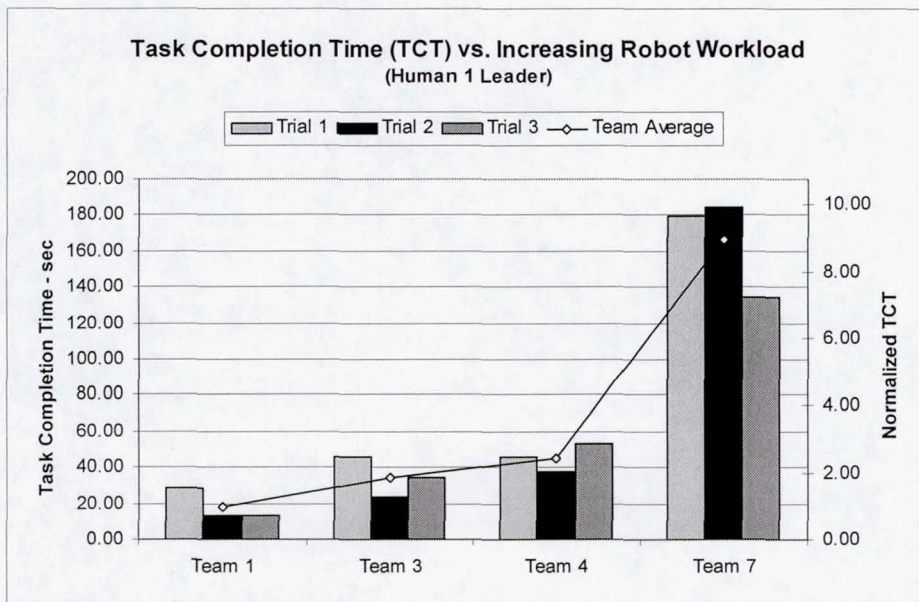

Fig. 11. Task Completion Time vs. Increasing Robot Workload (Human 1 Leader)

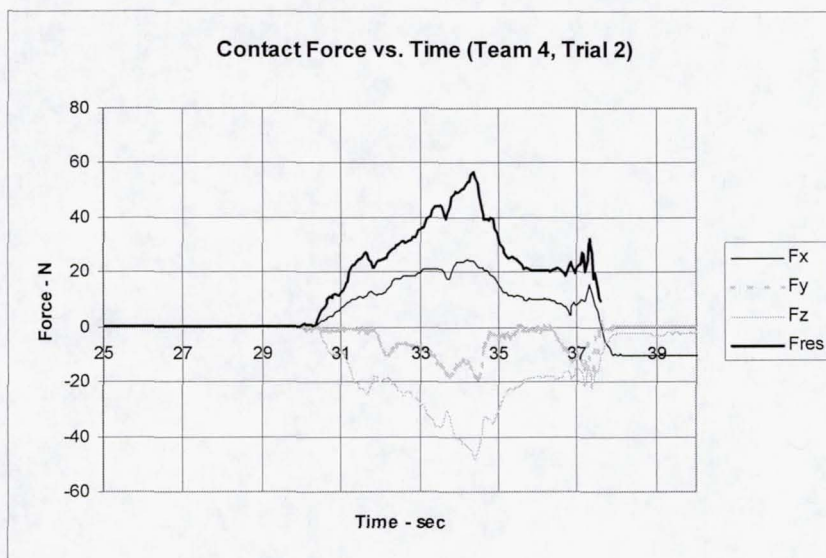

Fig. 12. Contact Force vs. Time (Team 4, Trial 2)

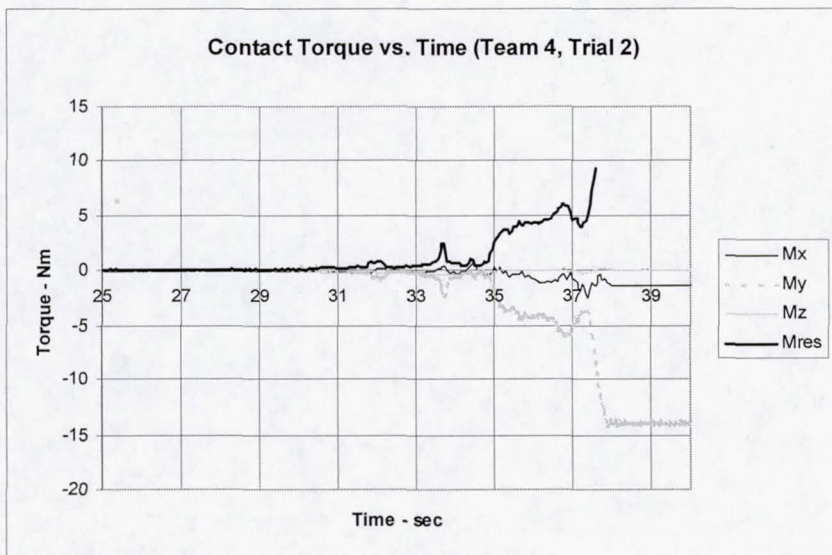

Fig. 13. Contact Torque vs. Time (Team 4, Trial 2)

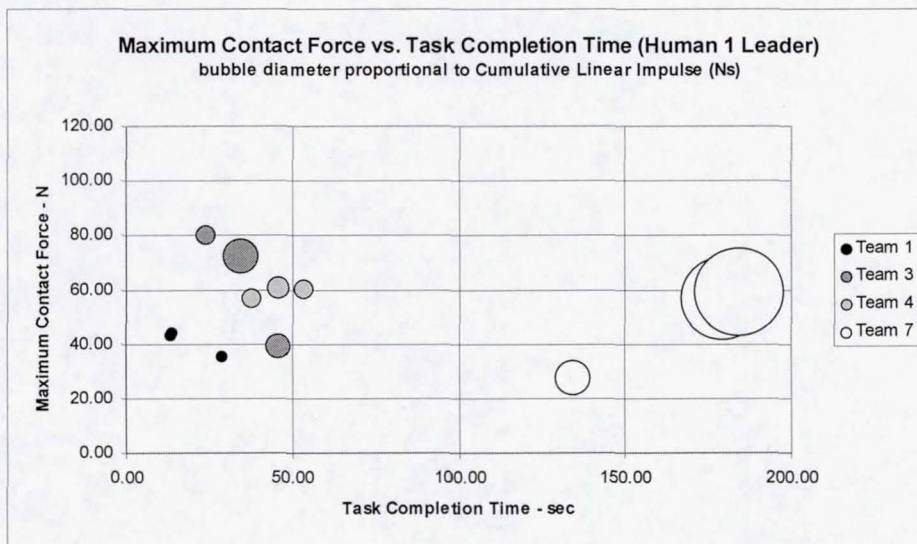

Fig. 14. Maximum Contact Force vs. Task Completion Time (Human 1 Leader)

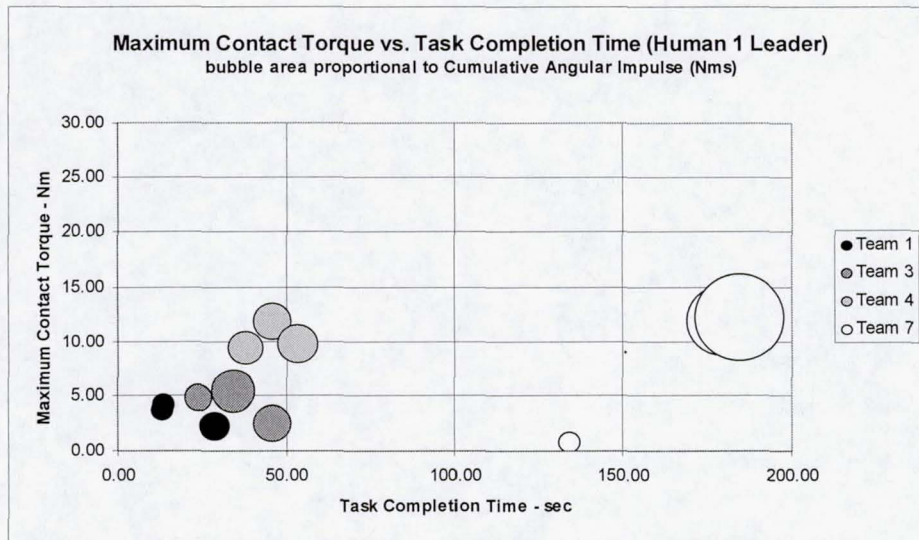

Fig. 15. Maximum Contact Torque vs. Task Completion Time (Human 1 Leader)