

## Nanosatellite Launch Adapter System (NLAS)

**Bruce D. Yost, John W. Hines, Elwood F. Agasid**  
NASA Ames Research Center

M/S:202-3, Moffett Field, CA 94035; (650)604-0681

[Bruce.d.yost@nasa.gov](mailto:Bruce.d.yost@nasa.gov), [John.w.hines@nasa.gov](mailto:John.w.hines@nasa.gov), [Elwood.f.agasid@nasa.gov](mailto:Elwood.f.agasid@nasa.gov)

**Steven J. Buckley**  
Operationally Responsive Space  
Kirtland AFB, NM 87117; (505)853-7799  
[steven.buckley@kirtland.af.mil](mailto:steven.buckley@kirtland.af.mil)

### ABSTRACT

The utility of small spacecraft based on the University cubesat standard is becoming evident as more and more agencies and organizations are launching or planning to include nanosatellites in their mission portfolios. Cubesats are typically launched as secondary spacecraft in enclosed, containerized deployers such as the CalPoly Poly Picosat Orbital Deployer (P-POD) system. The P-POD allows for ease of integration and significantly reduces the risk exposure to the primary spacecraft and mission. NASA/ARC and the Operationally Responsive Space office are collaborating to develop a Nanosatellite Launch Adapter System (NLAS), which can accommodate multiple cubesat or cubesat-derived spacecraft on a single launch vehicle. NLAS is composed of the adapter structure, P-POD or similar spacecraft dispensers, and a sequencer/deployer system. This paper describes the NLAS system and its future capabilities, and also provides status on the system's development and potential first use in space.

**KEYWORDS:** P-POD, cubesat, secondary payload

### BACKGROUND

Access to space has continually been an area of concern for a number of space agencies, both in terms of numbers of launch opportunities and costs associated with space lift. Traditional launch campaigns tend to be unique and require a significant amount of non-recurring engineering expense, sustaining a high cost structure. Presently, there are two major trends working in tandem to overcome access to space barriers.

The first of these innovations surrounds the emergence of low-cost launch vehicles in the space lift marketplace. Relatively new entrants such as Space Exploration Technologies (SpaceX) with their Falcon family of vehicles, and existing companies such as Orbital Sciences Corporation (OSC) with their Taurus and Minotaur product lines are making significant inroads into the cost component associated with launch vehicle production and operation. There are other companies in earlier stages of development that also may potentially add to this equation. Other developments such as the reduction of range support service costs are also contributing to reducing the overall prospect of mounting a space campaign.

The second trend is the willingness and ability of major launch programs to accommodate smaller spacecraft platforms as rideshares in order to maximize the utility of the overall launch campaign. This acceptance is largely based on the smaller spacecraft's ability to contribute a minimal if not zero risk component to the primary spacecraft's mission. The successful demonstration of secondary launch capability over the past 5 to 6 years has resulted in stimulating an emerging smallsat/nanosat spacecraft market, attracting high-level interest from both the scientific and operational space communities.

This paper addresses a development program that primarily addresses the second trend. The Nanosatellite Launch Adapter System (NLAS) is designed to build upon past successful multi-spacecraft launch missions, while protecting the primary spacecraft and mission operator from additional risk exposure from rideshare launches. While it is hopeful that the cost/unit to lift a kilogram of payload to orbit is decreasing, it is still problematic to buy a kilo (or few) of upmass. The NLAS attempts to remedy this by essentially fractionating lift.

## History

Co-manifesting spacecraft on launch programs is not new. Both the US and USSR as well as other nations have executed many missions with multiple spacecraft on a single launch vehicle. The advent of cubesats (<http://www.cubesat.org/>) earlier this decade has since resulted in a number of nanosatellite launches. In addition, cubesats and similar nano- or small satellite platforms are finding increasingly useful roles in science and exploration, while also providing an excellent training platform for future engineers and scientists.

([http://www.nsf.gov/funding/pgm\\_summ.jsp?pims\\_id=503172&org=GEO](http://www.nsf.gov/funding/pgm_summ.jsp?pims_id=503172&org=GEO)).

California Polytechnic University, San Luis Obispo, (CalPoly) has been instrumental in developing the first generations of cubesat launch adapters. The Poly-Picosat Orbital Deployer (P-POD) system has been in use since 2005 as a launch vehicle to spacecraft adapter for both foreign and domestic launchers. The key feature of the P-POD system is that it provides a containerization function, which physically separates the internally housed cubesat from the launch vehicle and primary or other spacecraft. This containerization approach, along with the P-POD's ease of integration, has been a significant factor in reducing overall mission risk for rideshare launches.

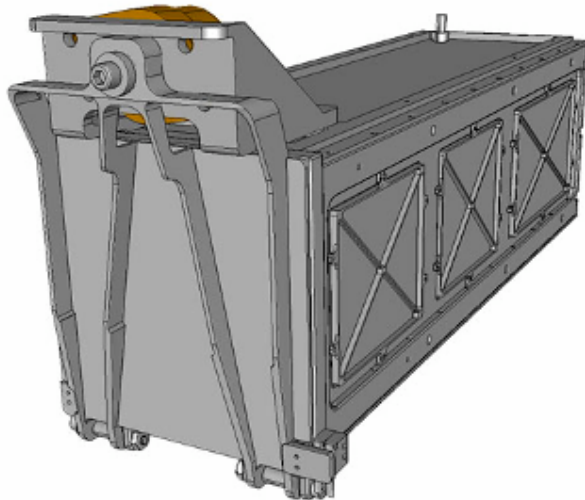

*P-POD Mk. III (Cal Poly SLO)*

In August 2008, DoD/Operationally Responsive Space organized a LEO mission informally designated Jumpstart. Jumpstart consisted of a military primary spacecraft and two secondary nanosatellites, both of which were provided by NASA. One of these 3U cubesats, named PreSat, was developed by NASA/Ames Research Center. PreSat was a technology demonstration for an upcoming operational

cubesat mission. The other 3U spacecraft was developed as part of a collaboration between ARC and the NASA Marshall Space Flight Center (MSFC). The Nanosail-D triple cubesat was a solar sail demonstration spacecraft, designed to investigate the use of large space sails for interplanetary propulsion and aerobraking.

In order to accommodate all three spacecraft, a Rideshare Adapter (RSA), originally developed for a foreign customer by Design\_Net Engineering, LLC, (<http://www.design-group.com/>) was used. The RSA “lifted” the primary spacecraft from the original separation plane in order to allow secondary spacecraft to be mounted on the exterior walls of the adapter. A sequencer was also provided to give the P-PODs their deployment signal at the correct time.

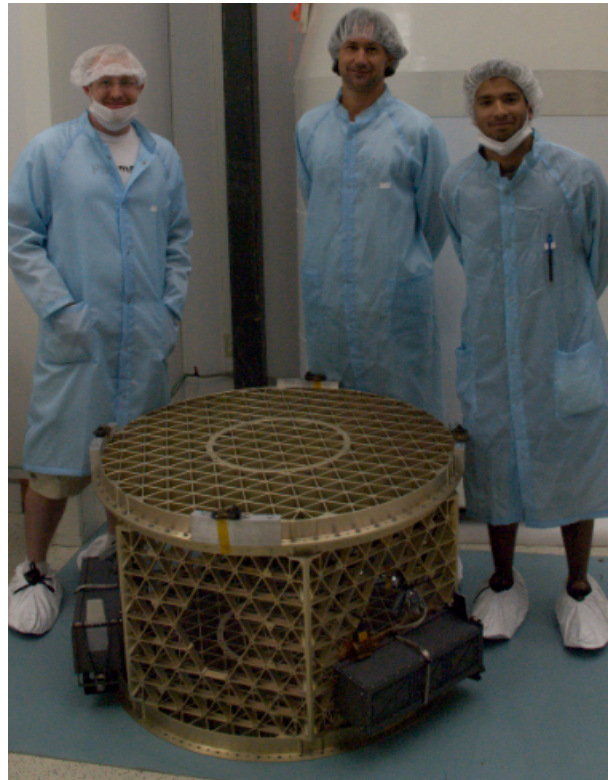

*RSA integrated with Presat and Nanosail-D.  
(Design\_Net LLC and ATSB<sup>TM</sup>)*

Unfortunately, the third Falcon-1 flight that the Jumpstart mission was manifested on did not reach orbit due to a vehicle staging anomaly. However, the integration of three spacecraft into a small lift mission paved the way to future designs and concepts.

**DESCRIPTION - Nanosat Launch Adapter System (NLAS)**

Following the Falcon-1 launch attempt in 2008, a number of small studies were initiated at NASA/ARC focused on adapters and multiple spacecraft accommodations solutions. Further discussions with ORS, industry, and others indicated that a similar adapter system to the RSA might find wide acceptance within the cubesat community and provide significant utility for government launch campaigns. (Unfortunately, the original RSA design is owned by a foreign corporation, and is, therefore, not readily available to domestic governmental launch agencies). In parallel, NASA/ARC was developing concepts that built upon the cubesat concept: modular spacecraft dimensions (1U, 3U, 6U, 12U etc.) using containerized launch adapters. From these initial studies and conversations, the Nanosat Launch Adapter System (NLAS) was envisioned.

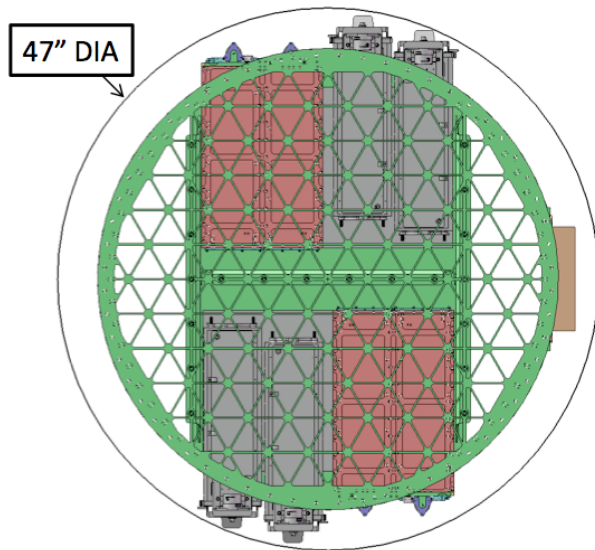

*Top view of NLAS showing a combination of 6U dispensers (x2) and P-PODs (x4)*

The NLAS consists of 3 major subsystems:

**Adapter structure.** The structure essentially raises the separation plane approximately 26 cm for the primary spacecraft. This dimension was selected to allow P-POD-type dispensers under the top deck, but also to limit the distance that the primary spacecraft must be raised in order to limit unacceptable dynamic loads issues. The structure includes all load bearing elements for the entire system. As it uses a 38.8” outer diameter, the NLAS adapter is designed to be compatible with both the SpaceX Falcon 1 series, as well as the OSC Minotaur I launchers.

The adapter structure is further designed to accommodate a primary spacecraft on the top deck. By using an isogrid design, configurations for 38.8” or 15” LightBand deployer mechanisms are possible. Final mass allowable for a primary is dependent on the mounting/deployer size used and the launch vehicle selected.

**Nanosatellite Dispensers.** As mentioned previously, the Nanosat Missions Office at ARC has larger than cubesat spacecraft form factors in mind, all of which are derived from the cubesat modular architecture. The first of these new configurations is roughly a combination of two 3U cubesats into one 6U form factor. To accommodate the 6U spacecraft, a new dispenser is being introduced into the NLAS architecture. The 6U dispenser occupies the same footprint and uses the same bolt hole mounting pattern as two 3U P-PODs placed side-by-side. If desired, a dividing wall can be configured down the center of the NASA 6U dispenser, and with the exchange of the pusher foot at the rear of the container, cubesat compatible 3U (or multiple 1U) spacecraft can also be accommodated. Finally, if P-PODs are required, up to 8 can be individually mounted within the adapter structure.

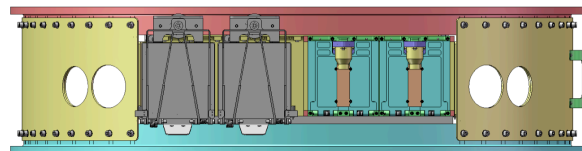

*Side view of the NLAS system. P-PODs (x2) on the left; 6U dispenser on the right. Sequencer mounting bracket shown on extreme right.*

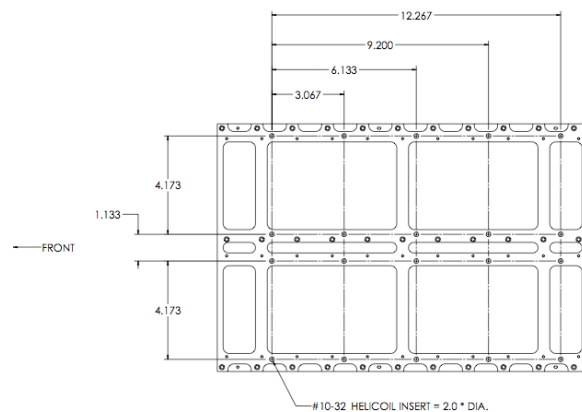

*Selected mounting pattern for the 6U dispenser. It essentially replicates two 3U (P-PODs) side by side.*

**Sequencer.** Finally, the NLAS also provides an electronic sequencer to release the P-POD or dispenser doors in a pre-determined manner. The sequencer accepts a traditional launch vehicle pyrotechnic signal and then issues separation commands to individual dispensers/P-PODs at the appropriate time. This allows mission designers to optimize deployment operations in order to ensure a low probability of recontact after ejection. The sequencer can forward up to 9 discreet signals; one for each 3U ejector (8), plus one more signal for other sequencers or events. The sequencer is mounted on the external side of the adapter structure. Cables are routed internally to the various dispenser/ejectors.

## DEVELOPMENT AND QUALIFICATION

Development of the NLAS system is a joint effort between the NASA/ARC Nanosat Missions Office located at Moffett Field, California and Operationally Responsive Space (ORS) at Kirtland AFB, New Mexico. NASA/ARC leads the design and development phase, with significant input and requirements from ORS, and ORS will perform qualification tests on the protoflight NLAS hardware system. Once all tests are successfully completed, NASA/ARC plans to license the NLAS system design to interested industrial parties. ORS and NASA intend to demonstrate the NLAS system on a mission in early to mid calendar 2011.

NLAS is being designed and tested to specifications that will qualify it for either the SpaceX Falcon 1E or OSC Minotaur I launch vehicles. The primary spacecraft mass carrying requirement is approximately 400 kg, but will ultimately be a function of the mission design and launch vehicle performance margins. Table 1 shows the current worst-case mass estimates for the NLAS.

**Table 1. NLAS Max Mass Estimates**

Element	Mass (estimated)	Remarks
Adapter Structure	85 kg	Structure plus cabling
Dispensers/P-PODs	25 kg	Assumes 8 @ 3 kg (3U)
Spacecraft	48 kg	6 kg each 3U
Sequencer	2 kg	Not including cabling
TOTAL	160 kg	In launch configuration

## FLIGHT VALIDATION

The NLAS is targeted for space demonstration in early to mid-2011. The launch vehicle will be a SpaceX Falcon 1E launched from Kwajalein Atoll in the

Pacific. The mission concept calls for two NLAS adapter structures accommodating fourteen 3U P-PODs (or equivalents) sponsored by the DoD, and one 6U spacecraft provided by NASA/ARC. A small DoD spacecraft will also be launched as the primary payload on top of the NLAS stack.

This will be the first flight of NLAS, and the 6U spacecraft form factor. The mission design calls for a LEO circular orbit at 450 km. Deployment scenarios as well as related mission operations concepts are currently under development.

## SUMMARY

The NLAS extends the successful use of containerized secondary spacecraft accommodations strategies for small launch vehicles. Combined with the expected low launch cost associated with next generation space lift, the ability to aggregate a number of small spacecraft willing and able to pay a fraction of marginal launch costs for secondary launch, will work to further erode access to space barriers. In addition, we expect that novel mission types and architectures will result from the capability that the NLAS and other similar systems will be able to contribute towards the achievement of critical mission goals.