

NASA Docking System (NDS) Interface Definitions Document (IDD)

**System Architecture and Integration Office
Engineering Directorate**

Date: November 2010
Revision: C

Verify that this is the correct version before use

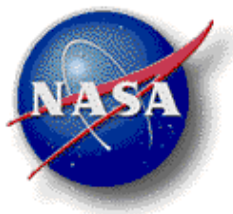

National Aeronautics and Space Administration
Houston, Texas 77058

NASA Docking System (NDS) Interface Definitions Document (IDD)

Prepared By:

<u>James Lewis</u>	<u>11-15-10</u>
Name	Date
James Lewis	
Project Manager, EA3	

Approved By:

<u>Bruce W. Sauser</u>	<u>11-15-10</u>
Name	Date
Bruce Sauser	
Systems Architecture and Integration Office, Manager, EA3-1	

<u>Caris A. Hatfield</u>	<u>11/15/10</u>
Name	Date
Caris (Skip) Hatfield	
CDA Project Manager, OA	

Change Record

Rev.	Description	Date
Basic	Initial issue	05/2010
A	Revised to add definition to the interface by removing TBDs and providing updates based on matured design. Sections 4 and 5 swapped as well as including Section 6 in Section 5 in order to improve readability by discussing the docking interface prior to the host interface.	07/2010
B	Changed Export Control designation from ITAR to EAR. Made non-technical editorial changes. Updated errata documenting comments from NDS Baseline Review.	08/2010
C	Incorporated changes approved during the NDS Baseline Review. Added definition of -301, -302, -303, and -304 configurations. Added IDs to interface definition requiring verification. Added section 7 describing Host Requirements for NDS Integration. Removed Export Control EAR designation. Document can be released in the public domain.	11/2010

Table of Contents

Section	Page
1.0 INTRODUCTION.....	1-1
1.1 Purpose and Scope.....	1-1
1.2 Responsibility and Change Authority.....	1-2
2.0 APPLICABLE AND REFERENCE DOCUMENTS.....	2-1
2.1 Applicable Documents.....	2-1
2.2 Reference Documents.....	2-1
2.3 Order of Precedence.....	2-2
3.0 GENERAL SYSTEM OVERVIEW.....	3-1
3.1 System Description.....	3-1
3.2 Mass Properties.....	3-4
3.3 Volume Properties.....	3-5
3.4 Mating Plane Definition.....	3-5
3.5 Units of Measure, Dimensions, and Tolerances.....	3-6
3.6 Coordinate System.....	3-6
3.6.1 NDS Coordinate System.....	3-6
4.0 NDS DOCKING INTERFACE.....	4-1
4.1 Structural/Mechanical.....	4-2
4.1.1 Thermal Interface.....	4-4
4.1.2 Soft Capture System.....	4-8
4.1.3 Hard Capture System.....	4-18
4.1.4 Loads.....	4-27
4.1.5 Leak Rate.....	4-30
4.2 Electrical Interfaces.....	4-30
4.2.1 Electrical Bonding.....	4-30
4.3 Resource Transfer.....	4-32
4.3.1 Power Transfer and Command and Data Handling Transfer Umbilical....	4-33
4.3.2 Water Transfer.....	4-34
4.3.3 Fuel Transfer.....	4-34
4.3.4 Pressurant Transfer.....	4-34
4.3.5 Oxidizer Transfer.....	4-34
5.0 NDS-TO-HOST VEHICLE INTERFACE.....	5-1
5.1 Interface Description.....	5-1
5.2 Structural/Mechanical/Seal.....	5-1
5.2.1 Mounting Interface.....	5-2
5.2.2 Mechanical Mounting and Seal Interface.....	5-8
5.2.3 Thermal Interface.....	5-9
5.3 NDS-to-Host Vehicle Electrical and Signal Interface.....	5-11
5.3.1 Umbilical Power Transfer Interface-to-Host Vehicle.....	5-13
5.3.2 Umbilical Data Transfer Interface-to-the Host Vehicle.....	5-13
5.3.3 Pyrotechnic Interface NDS (-301 and -303).....	5-13

5.3.4	Electrical Power from Host Vehicle-to- NDS.....	5-15
5.3.5	Communications Between the Host Vehicle and the NDS	5-15
5.3.6	Heater Power and Control	5-17
5.3.7	GSE Software Interface to NDS	5-18
5.3.8	Electrical Bonding Between the Host Vehicle and the NDS	5-19
5.4	NDS-to-Host Vehicle Software Interface	5-19
5.4.2	NDS Packet Structures.....	5-24
5.4.3	NDS Data Transfer	5-28
5.4.4	Command List	5-29
5.4.5	Measurement List.....	5-29
5.5	NDS-to-Host Vehicle Connectors Locations.....	5-29
5.5.1	NDS (excluding -302) Power Transfer Interface to Host Vehicle Connector Location.....	5-33
5.5.2	NDS (excluding -302) Data Transfer Interface to Host	5-33
5.5.3	Water Transfer	5-34
5.5.4	Fuel Transfer	5-34
5.5.5	Pressurant Transfer.....	5-34
5.5.6	Oxidizer Transfer.....	5-34
6.0	NDS-TO-GROUND SUPPORT EQUIPMENT INTERFACE	6-1
6.1	Structural/Mechanical.....	6-1
6.1.1	Lifting Interface.....	6-1
6.1.2	Seal Cover Interface.....	6-1
6.1.3	Pressure Dome Interfaces.....	6-1
6.1.4	Pressure Seal Interface, Pass-Through Connectors	6-1
6.1.5	Pressure Seal Interface, Test Ports.....	6-1
6.1.6	Handling Fixture Interface	6-4
6.1.7	Instrument Checkout	6-5
6.2	Electrical Interfaces for Command and Data Handling.....	6-5
7.0	HOST REQUIREMENTS FOR NASA DOCKING SYSTEM INTEGRATION.....	7-1
APPENDIX A	ACRONYMS AND ABBREVIATIONS.....	A-1
APPENDIX B	DEFINITION OF TERMS	B-1
APPENDIX C	NDS COMMANDS LIST	C-1
APPENDIX D	NDS MSID.....	D-1
APPENDIX E	NDS CONFIGURATION DIFFERENCES	E-1
APPENDIX F	HOST INTERFACE CONNECTOR PINOUTS [R.LIDS.5037]	F-1
APPENDIX G	FAILURE RESPONSE TABLES	G-1
APPENDIX H	ERRATA AND TBD/TBR – LIST	H-1

List of Tables

Section	Page
Table 3-1: Mass Properties	3-5
Table 4-1: NDS Initial Contact Conditions “Design To” Limits ⁽¹⁾⁽²⁾⁽³⁾⁽⁴⁾⁽⁵⁾ [R.LIDS.0063].....	4-17
Table 4-2: SCS Maximum Docking Loads.....	4-28
Table 4-3: SCS Maximum Component Loads	4-28
Table 4-4: HCS Maximum Mated Loads	4-29
Table 4-5: HCS Mated Load Sets	4-29
Table 4-6: FRAM-Type Connector Pinouts [R.LIDS.5022].....	4-33
Table 5-3: Host Vehicle-to-NDS Command Packet.....	5-24
Table 5-4: Host Vehicle-to-NDS Command Packet Parameters	5-25
Table 5-5: NDS-to-Host Vehicle H&S Packet.....	5-25
Table 5-6: NDS-to-Host Vehicle H&S Packet Parameters	5-26
Table 5-7: NDS-to-Host Vehicle H&S Packet Types	5-27
Table 5-8: NDS-to-Host Vehicle H&S Command Response Types	5-27
Table 5-9: Transfer Frame Packet Structure	5-28
Table 5-10: Transfer Frame Parameter Definitions	5-28
Table 5-11: CRC-CCITT Parameters	5-28
Table 5-12: NDS-to-Host Vehicle C&DH Interface Layers	5-29

List of Figures

Figure 1-1: IDD Structure	1-2
Figure 3-1: NDS System Functional Interface Diagram.....	3-3
Figure 3-2: NDS (-301 and -303).....	3-4
Figure 4-1: NDS Docking Interface Diagram	4-1
Figure 4-2: NDS Docking Interface.....	4-2
Figure 4-3: NDS Cross Section [R.LIDS.5003].....	4-3
Figure 4-4: NDS Mating Interface Allowable Thermal Differential for Hard Capture [R.LIDS.5007].....	4-6
Figure 4-5: NDS Post Hard Mate Warm Up Profile	4-7
Figure 4-6: NDS Capture Ring in Passive Mode [R.LIDS.5008].....	4-8
Figure 4-7: NDS Capture Ring in Active Mode [R.LIDS.5009]	4-9
Figure 4-8: SCS Guide Petal System [R.LIDS.5010]	4-10
Detail Side View	4-11
Figure 4-9: SCS Guide Petal System Detail [R.LIDS.5011]	4-11
Figure 4-10: SCS Guide Petal System Profile [R.LIDS.5012]	4-14
Figure 4-11: Guide Petal Removal – IVA Interface	4-15
Figure 4-12: SCS Magnetic Capture System [R.LIDS.5013].....	4-16
Figure 4-13: HCS Docking Interface [R.LIDS.0029]	4-19

Figure 4-14: NDS (excluding -302) HCS Mating Plane Seal and Electrical Bonding Details [R.LIDS.5015].....	4-20
Figure 4-15: NDS (-302) HCS Mating Plane Seal and Electrical Bonding Details [R.LIDS.5016].....	4-21
Figure 4-16: HCS Guide Pin Detail [R.LIDS.1005].....	4-22
Figure 4-17: HCS Guide Pin Hole Detail [R.LIDS.1005].....	4-23
Figure 4-18: HCS Hook Configurations [R.LIDS.0029].....	4-24
Figure 4-19: HCS Active Hook Detail [R.LIDS.1124].....	4-25
Detail View	4-26
Figure 4-20: HCS Passive Hook Detail (Excluding -304) [R.LIDS.1125].....	4-26
Figure 4-21: NDS Electrical Bonding.....	4-31
Figure 4-22: NDS Resource Transfer.....	4-32
Figure 5-1: NDS-to-Host Vehicle Interface Diagram.....	5-1
Figure 5-2: NDS (-302) Host Provided MMOD Interface	5-3
Figure 5-3: NDS-to-Host Vehicle Mounting Interface [R.LIDS.0001].....	5-8
Figure 5-4: NDS Post Hard Mate Warm Up Profile	5-10
Figure 5-5: NDS-to-Host Vehicle Electrical Interface [R.LIDS.5030].....	5-12
Figure 5-6: Maximum Pyroshock Levels at NDS/Host I/F for Contingency Pyrotechnic NDS Separation	5-14
Figure 5-7: Block Diagram TIA-422-B Serial Communications Host Vehicle to NDS	5-16
Figure 5-8: Block Diagram MIL-STD-1553B Serial Communications Host Vehicle to NDS.....	5-16
Figure 5-9: Safe Operation Area for TIA-422-B C&DH Serial Port [R.LIDS.5033].....	5-17
Figure 5-10: Host Vehicle-to-NDS Command Handling Interface	5-20
Figure 5-11: Host Vehicle-to-NDS H&S Data Handling Interface	5-21
Figure 5-12: Host Vehicle-to-NDS FDIR Handling Interface.....	5-23
Figure 5-13: NDS (excluding -302) to Host Vehicle Electrical Interface	5-30
Figure 5-14: NDS (excluding -302) Box Connections-to-Host Vehicle Electrical Interface	5-31
Figure 5-15: NDS (excluding -302) Tunnel Connections-to-Host Vehicle Electrical Interface [R.LIDS.5036].....	5-31
Figure 5-16: NDS (-302)-to-Host Vehicle Electrical Interfaces	5-32
Figure 5-17: NDS (-302) Remote Electrical Boxes.....	5-33
Figure 6-1: Leak Test Port Locations (excluding -302).....	6-2
Figure 6-2: Leak Test Port Cross Section	6-3
Figure 6-3: Leak Test Port Detail	6-4
Figure 6-4: Handling Fixture Interface to NDS Bolt Pattern.....	6-5

1.0 INTRODUCTION

The NASA Docking System (NDS) mating system supports low approach velocity docking and provides a modular and reconfigurable standard interface, supporting crewed and autonomous vehicles during mating and assembly operations.

The NDS is NASA's implementation for the emerging International Docking System Standard (IDSS) using low impact docking technology. All NDS configurations can mate with the configuration specified in the IDSS Interface Definition Document (IDD) released September 21, 2010. The NDS evolved from the Low Impact Docking System (LIDS). The acronym international Low Impact Docking System (iLIDS) is also used to describe this system. NDS and iLIDS may be used interchangeably. Some of the heritage documentation and implementations (e.g., software command names) used on NDS will continue to use the LIDS acronym.

1.1 Purpose and Scope

The NDS IDD defines the interface characteristics and performance capability of the NDS, including uses ranging from crewed to autonomous space vehicles and from low earth orbit to deep space exploration.

The responsibility for developing space vehicles and for making them technically and operationally compatible with the NDS rests with the vehicle providers. Host vehicle examples include crewed/uncrewed spacecraft, space station modules, elements, etc. Within this document, any docking space vehicle will be referred to as the host vehicle. This document defines the NDS-to-NDS interfaces, as well as the NDS-to-host vehicle interfaces and performance capability.

This IDD is an applicable document to future Interface Requirement Documents (IRDs). It is also an applicable document for JSC-63686, Project Technical Requirements Specification for the International Low Impact Docking System document as a directed interface from the NASA Docking System Project (NDSP). In order to identify interfaces that must be verified by the NDS Project, requirement identification numbers of the format, R.LIDS.0000, have been added to this document. Further, requirements for the host vehicles are identified with IDs R.LIDS.6000 and higher. It is up to implementers to examine the Project Technical Requirements Specification (PTRS) and the IDD to determine if there are any issues regarding the implementation of the NDS on their vehicle. Refer to Figure 1-1: IDD Structure.

Other docking relevant requirements outside of the docking system interfaces, such as navigation systems and propulsion, will be covered in other documentation/agreements between the host vehicles. Specific NDS-to-vehicle Interface Control Documents (ICDs) and specifications will be addressed on a case-by-case basis.

This document contains requirements for four NDS configurations: SEZ29101800-301, SEZ29101800-302, SEZ29101800-303, and SEZ29101800-304. This document will use the term "NDS" when the interface description describes all

configurations. Specific differences will be addressed by referring to the dash number(s) where the description is applicable. For example, the text will contain statements such as “(-301 and -303 only)” or “(excluding -302)” to identify that the interface description only applies to certain configurations.

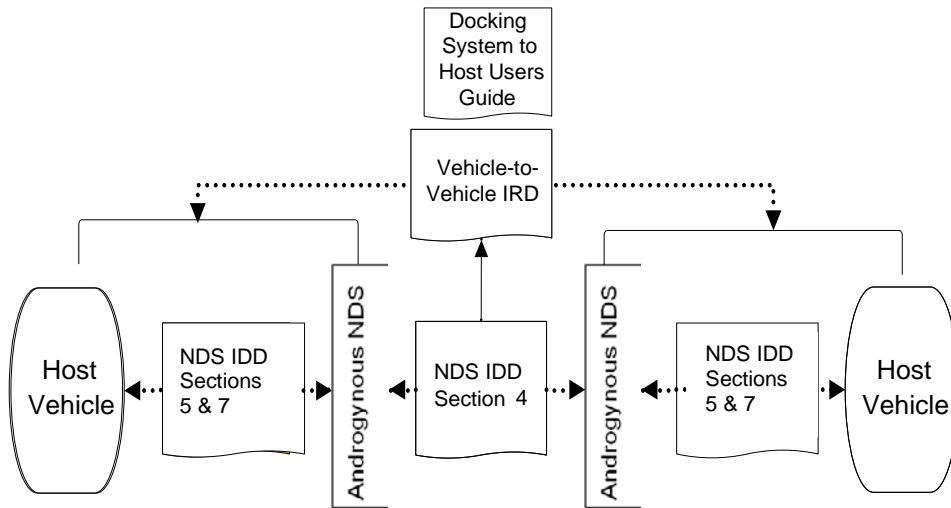

Figure 1-1: IDD Structure

1.2 Responsibility and Change Authority

The responsibility for this document, including change authority, rests with the NDS Project Office.

2.0 APPLICABLE AND REFERENCE DOCUMENTS

2.1 Applicable Documents

The following documents, of the exact date and revision shown, form a part of this document to the extent specified herein.

Document Number	Revision/ Release Date	Document Title
684-016105	Draft available March 15, 2011	Drill Template, NDS – Host Interface
D684-14211-01	Draft available June 2011	iLIDS FRAM Connector Test Evaluation
JSC-62809	Rev D April 22, 2010	Human Rated Spacecraft Pyrotechnic Specification
JSC-64599	Draft Sept 2010	Electric Power Quality Description Document
JSC-65842	Draft Sept 2010	Electromagnetic Environmental Effects (E3) Requirements Document
JSC-65970	Baseline/ November 5, 2010	iLIDS Thermal and Induced Environments
MIL-A-8625	Rev. F 9/10/1993	Anodic Coatings for Aluminum and Aluminum Alloys
MIL-DTL-5541	Rev. F 7/11/2006	Chemical Conversion Coatings on Aluminum and Aluminum Alloys
MIL-STD-1553B	Rev. B, Notice 2 09/8/1986	Digital Time Division Command/Response Multiplex Data Bus
NASA-STD-4003	Rev. Basic 09/08/2003	Electrical Bonding for NASA Launch Vehicles, Spacecraft, Payloads, and Flight Equipment
SSP 30559	Rev D July 27, 2007	Structural Design and Verification Requirements
SKZ29101796	Draft available March 15, 2011	NDS Guide Petal Removal/Installation Procedure
SKZ29101797	Draft available March 15, 2011	NDS to Host Installation Procedure
TIA-422-B	Rev B May 1994	Electrical Characteristics of Balanced Voltage Digital Interface Circuits

2.2 Reference Documents

The following documents are reference documents used in the development of this document. These documents do not form a part of this document, and are not controlled by their reference herein.

Document Number	Revision/ Release Date	Document Title
ARP 5412	Rev A February 2005	Aircraft Lightning Environment and Related Test Waveforms
JSC-26938	Rev D June 2009	Procurement Specification for the Androgynous Peripheral Docking System for the ISS Missions
JSC-63686	Rev B July 2010	Project Technical Requirements Specification for the International Low Impact Docking System
JSC-63844	Draft Available March 15, 2011	NDS Capture Performance Data Book
JSC-64096	Rev C September 2010	Software Requirements Specification for the ILIDS Control System Software
JSC-65978	Draft available March 15, 2011	iLIDS Thermal Data Book

2.3 Order of Precedence

This document provides a set of interface definitions to support integrating the NDS with existing and future space vehicles. In the event of conflict between the text of this document and any other document, the NDS IDD takes precedence over other documents.

3.0 GENERAL SYSTEM OVERVIEW

The following subsections describe the system interfaces for the NDS. Interface responsibilities are defined with respect to the interface boundaries in Figure 3-1: NDS System Functional Interface Diagram.

3.1 System Description

The NDS is a peripheral docking system. NDS (-301 and -303) are fully androgynous, meaning the configurations are capable of mating to an identical configuration. In addition, the fully androgynous NDS configurations can mate to all other NDS configurations. The exceptions are; NDS (-302) cannot mate to its identical configuration. NDS (-304) cannot operate as a configuration in passive mode.

The NDS facilitates low approach velocity docking via a reconfigurable, active, closed-loop, and force-feedback controlled mating system using modern technologies. The NDS supports both crewed and autonomous vehicles during mating and assembly operations. In addition, it is modular and reconfigurable for variety of missions.

The NDS establishes the initial capture of two vehicles through the Soft Capture System (SCS). The SCS uses the low impact docking technology. The SCS consists of guide petals, magnets, magnetic striker plates (excluding -304), scarring for SCS mechanical latch striker interfaces, electromechanical actuators in a Stewart platform configuration, and load sensing rings. During docking soft capture, the guide petals are the first element to make contact, transferring contact/load inputs into the load sensing load cells. The load cells provide information to drive the electromechanical actuators to correct lateral and angular misalignment between the two opposing interfaces. Soft capture is complete when electromagnetic attachment of the magnets to the striker plates on the opposing capture ring occurs. The SCS then aligns the two mating vehicles and retracts to bring the two hard capture interfaces into hard capture range.

The Hard Capture System (HCS) uses powered hooks to engage with the passive system, providing a structural connection ready for pressurization between the mated vehicles that allows for cargo and crew transfer. The HCS consists of a tunnel, 12 active/passive hook pairs, seals, fine alignment guide pins, mechanized separation springs, and mechanized umbilicals.

The docking is complete when mechanized resource transfer umbilicals are extended and engaged with the spring-loaded separation system energized for undocking.

The NDS is a docking system that can be commanded via NDS electronics interface from the host in either an active mode or passive mode. Active mode is when the NDS controls the soft capture function and all sequences of docking. Passive mode is when the NDS yields control and allows the NDS on the other vehicle, in active

mode, to mate to it. Figure 3-2: NDS (-301 and -303) depicts the Androgynous NDS.

In support of the NDSP, four NDS configurations are used: the -301, -302, -303, and -304.

The -301 is a standalone assembly with all required hardware [e.g. Micro Meteoroid Orbital Debris (MMOD) shielding, electrical boxes, etc.] contained in the assembly. The -301 can dock to another -301 or any other configuration of the NDS.

The -302 has most of the same functionality as the -301. The main difference is the electrical boxes are integrated in the host vehicle rather than the docking system assembly. Hence, the tunnel structure is shorter (i.e., compact). In addition, the -302 relies on the host for MMOD shielding. Further, the -302 does not contain a seal on the mating surface, which would support longer duration missions such as for the International Space Station (ISS) Common Docking Adapter (CDA). Therefore the NDS-302 cannot dock to another -302 but it can dock to all other NDS configurations that have a seal at the interface (-301, 303, and -304). However, the -302 will not be initially certified to perform powered soft capture. Therefore, the -302 will only initially be certified for passive mode operations.

The -301 and -302 will be the first units produced by the NDSP with the -301 slated for use on visiting vehicles to the ISS and the -302 on the CDA and docking hub. The -303 and -304 will be available upon request.

The -303 is identical to -301 with the exception that it operates on 28 Vdc instead of 120 Vdc.

The -304 is identical to the -301 with the exception that magnets, passive hooks, and pyrotechnics have been removed to reduce mass.

For complete list of configuration differences between the dash numbers, refer to APPENDIX E.

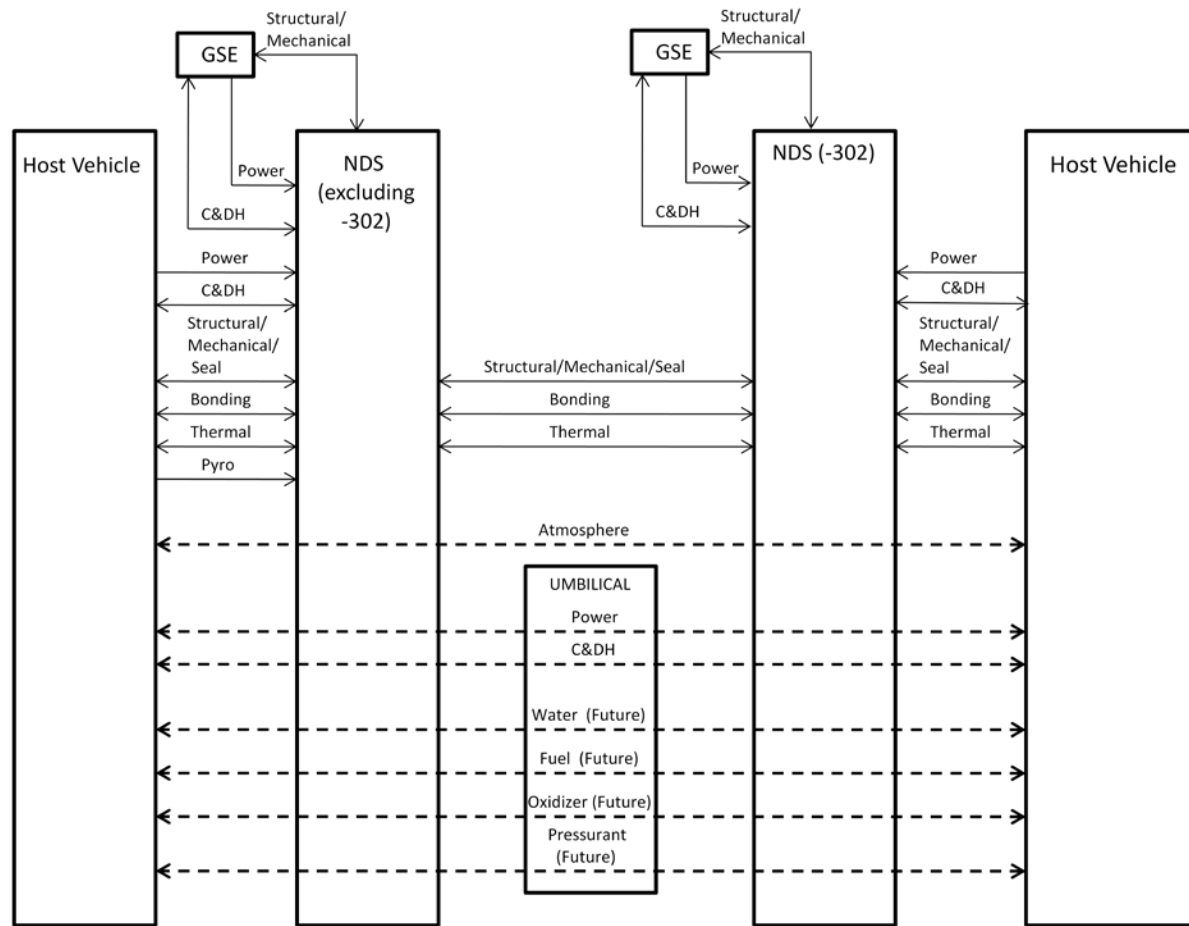

_____ Solid lines = functional interfaces

----- Dashed lines = pass-through resources vehicle-to-vehicle

Pyro is not available on -302 or -304.

Figure 3-1: NDS System Functional Interface Diagram

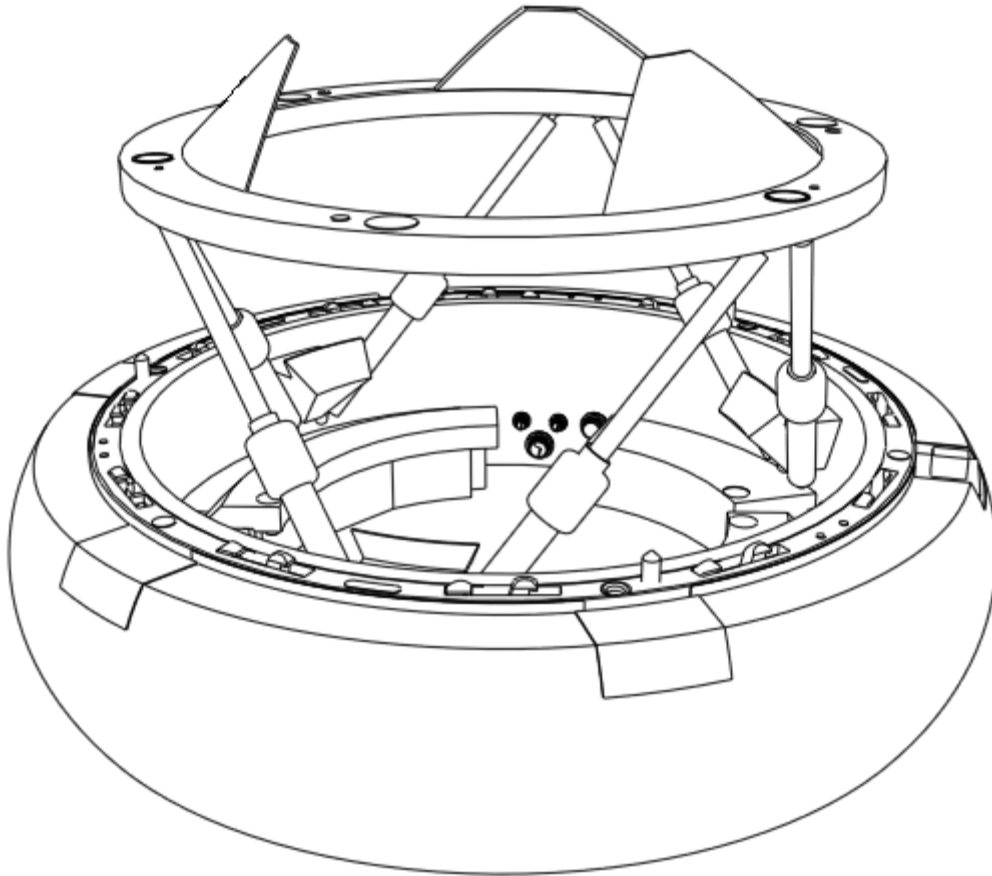

Note: Refer to APPENDIX E for complete list of configuration differences.

Figure 3-2: NDS (-301 and -303)

3.2 Mass Properties

The mass properties described in Table 3-1: Mass Properties reference the NDS center of gravity relative to the coordinate system defined in Figure 4-2: NDS Docking Interface and Figure 4-3: NDS Cross Section.

Table 3-1: Mass Properties

	Mass (Not to Exceed) lb (kg)	Inertia⁽²⁾ xx lb-in² (kg-mm²)	Inertia⁽²⁾ yy lb-in² (kg-mm²)	Inertia⁽²⁾ zz lb-in² (kg-mm²)	Center of Gravity X,Y,Z in. (mm)
NDS (-301 & -303) [R.LIDS.0080]	750 lb (341 kg)	2.348E+05 lb-in ² (6.87E+07 kg-mm ²)	2.485E+05 lb-in ² (7.272E+07 kg-mm ²)	4.516E+05 lb-in ² (1.322E+08 kg-mm ²)	X = 0.022 in. (0.6 mm) Y = 0.708 in. (18.0 mm) Z = 8.777 in. (222.9 mm)
NDS (-302) [R.LIDS.1056]	704 lb ⁽¹⁾ (320 kg)	TBD-2	TBD-2	TBD-2	
NDS (-304) [R.LIDS.5000]	711 lb (323 kg)	TBD-2	TBD-2	TBD-2	

Notes:

1. The -302 mass listed does not include host-supplied components [e.g., MMOD shield, Thermal Protection System (TPS), etc.]. This document will define excluded integration components. The mass of these host-provided integration components is dependent on the host implementation. The -302 mass listed does include cabling and electrical box mass for the NDS-provided, host-mounted boxes.
2. Moments of inertia are based on the nominal center of gravity location.

3.3 Volume Properties

For host Environmental Control and Life Support System (ECLSS) analysis, the following worst case volumes may be used. The NDS (excluding -302) internal vestibule volume is not to exceed 16.64 ft³ (.47 m³) [R.LIDS.5001]. The NDS (-302) internal vestibule volume is not to exceed 9.90 ft³ (.28 m³) [R.LIDS.5002]. This volume is defined from the NDS mounting plane to the NDS HCS mating plane. The calculated volume assumes no hardware inside the pressure wall of the NDS tunnel. Therefore, the actual volume will be slightly less.

3.4 Mating Plane Definition

The HCS mating plane is defined as the seal plane between HCS tunnels when structurally mated. See Figure 4-6: NDS Capture Ring in Passive Mode and Figure 4-7: NDS Capture Ring in Active Mode [R.LIDS.5009] for illustrations of the mating planes.

The SCS mating plane is the plane normal to the soft capture ring axis and intersects the conic outline of the guide petals at a diameter of 1045 mm. Additional details follow for SCS-specific modes:

- A. Passive Mode: When the SCS capture ring is stowed and the docking system is in the passive mode, the magnetic strikers are coplanar with the SCS mating plane; see Figure 4-6.
- B. Active Mode: When the SCS capture ring is extended and the docking system is in the active mode, the magnets are coplanar with the SCS mating plane and the strikers are to be at least 1.5 mm below this plane; see Figure 4-7.

3.5 Units of Measure, Dimensions, and Tolerances

Unless otherwise noted herein, all dimensions in this document are shown in the English system of inch-pound units followed by the System International (SI) in parenthesis or square brackets. All dimensions shown in this document assume ambient conditions [i.e., 70 °F (21 °C) and 14.7 psi (1013.5 hPa)]. Linear tolerances on metric dimensions are derived from English measurements and tolerances. Implied tolerances on linear dimensions are defined in Table 3-2: Linear Tolerances. Angular tolerances are shown in Table 3-3: Angular Tolerances. Dimensions enclosed within parenthesis are for reference only and provide no tolerance. Orthographic projections are constructed using the third angle projection system.

Table 3-2: Linear Tolerances

English Dimensions	Implied Tolerances	
	(Inches)	(Millimeters)
x.x	± .1	± 2.5
x.xx	± .02	± .5
x.xxx	± .005	± .13

Table 3-3: Angular Tolerances

Dimensions	Tolerances
Angular dimension (degrees)	± .5 degrees

3.6 Coordinate System

3.6.1 NDS Coordinate System

The NDS coordinate system is shown in Figure 4-2 and Figure 4-3. The origin of the coordinate system is defined as the intersection of the NDS cylindrical axis and the HCS mating plane.

4.0 NDS DOCKING INTERFACE

This section describes the interfaces between two NDS assemblies. Specific implementation differences for various NDS configurations will be noted where applicable.

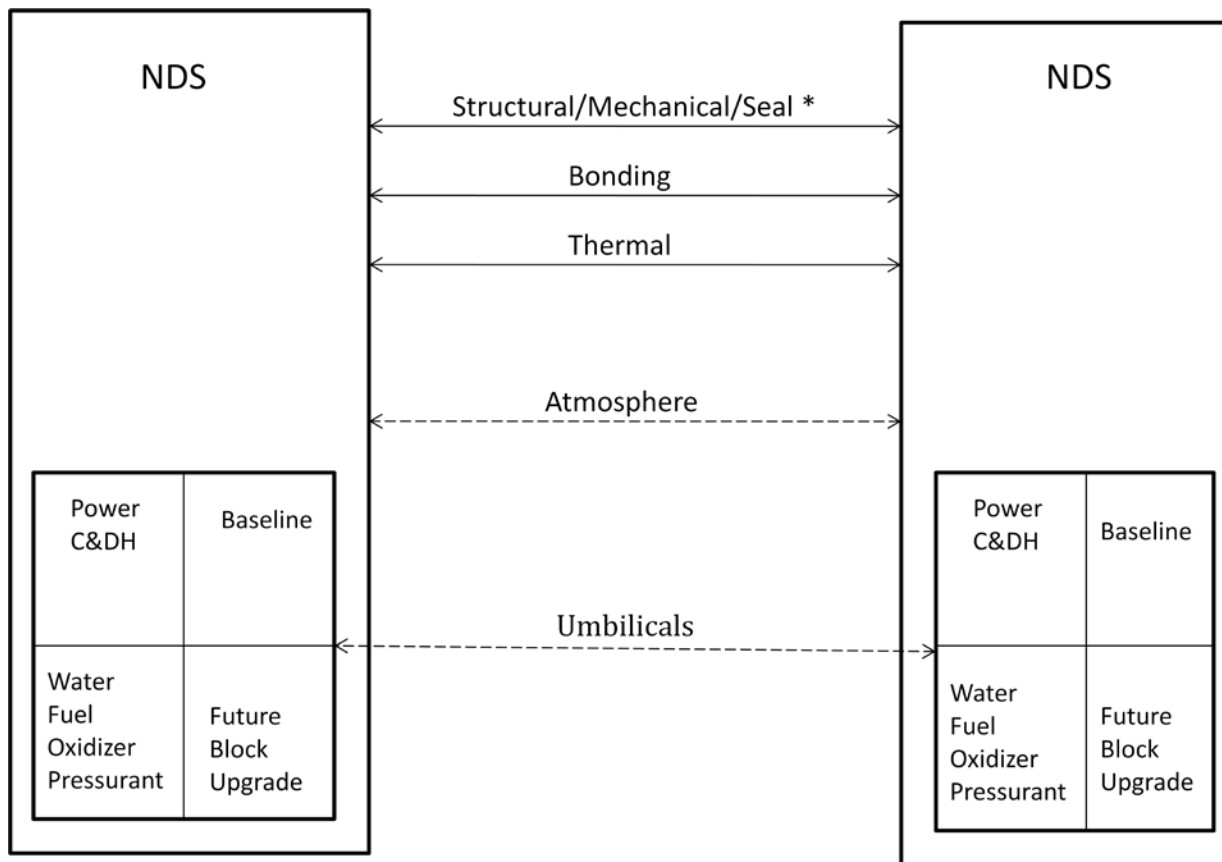

————— Solid lines = functional interfaces
 - - - - - Dashed lines = pass-through resources vehicle to vehicle
 * Seal is not on -302. Passive hooks and magnetic strikers are not available on -304. Therefore, -302 or -304 cannot dock to itself.

Figure 4-1: NDS Docking Interface Diagram

4.1 Structural/Mechanical

When two NDS units dock, the initial connection occurs in the SCS between the magnets on the active mode NDS and the striker plates on the passive mode NDS. Once the soft capture phase is finished, the HCS on the active mode NDS completes the docking structural connection via the latch system. Any two NDS units can only mate with a unique relative clocking orientation, which is determined by the pair of adjacent guide pin and guide pin receptacle on the HCS shown in Figure 4-2. The volume and keep out zones are defined in Figure 4-3: NDS Cross Section [R.LIDS.5003].

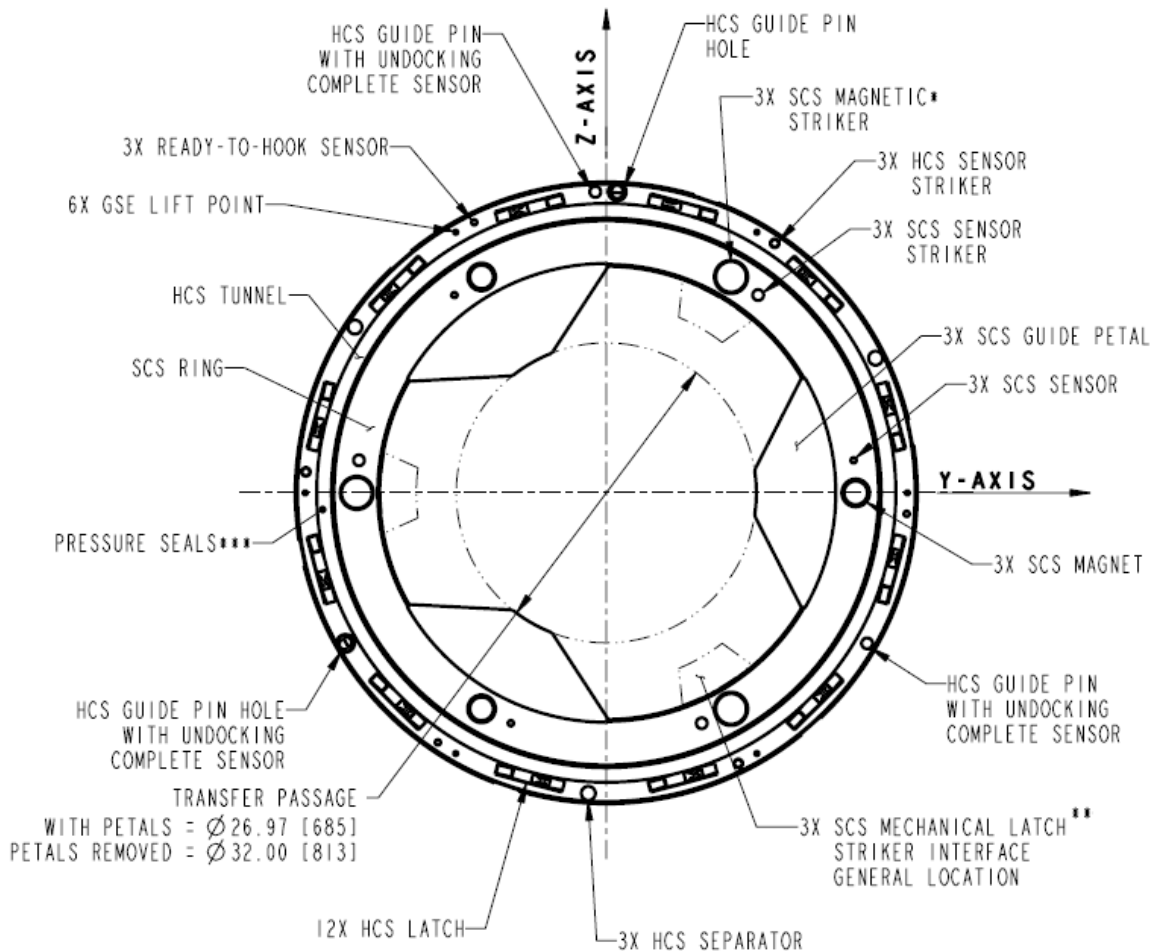

Notes:

MMOD shield and umbilicals are not shown for clarity.

* Not applicable for NDS (-304).

For a complete list of configuration differences, refer to APPENDIX E.

** Indicates allocated area for SCS mechanical latch implementation (this is not part of the NDS configuration).

*** Not applicable for NDS (-302).

Figure 4-2: NDS Docking Interface

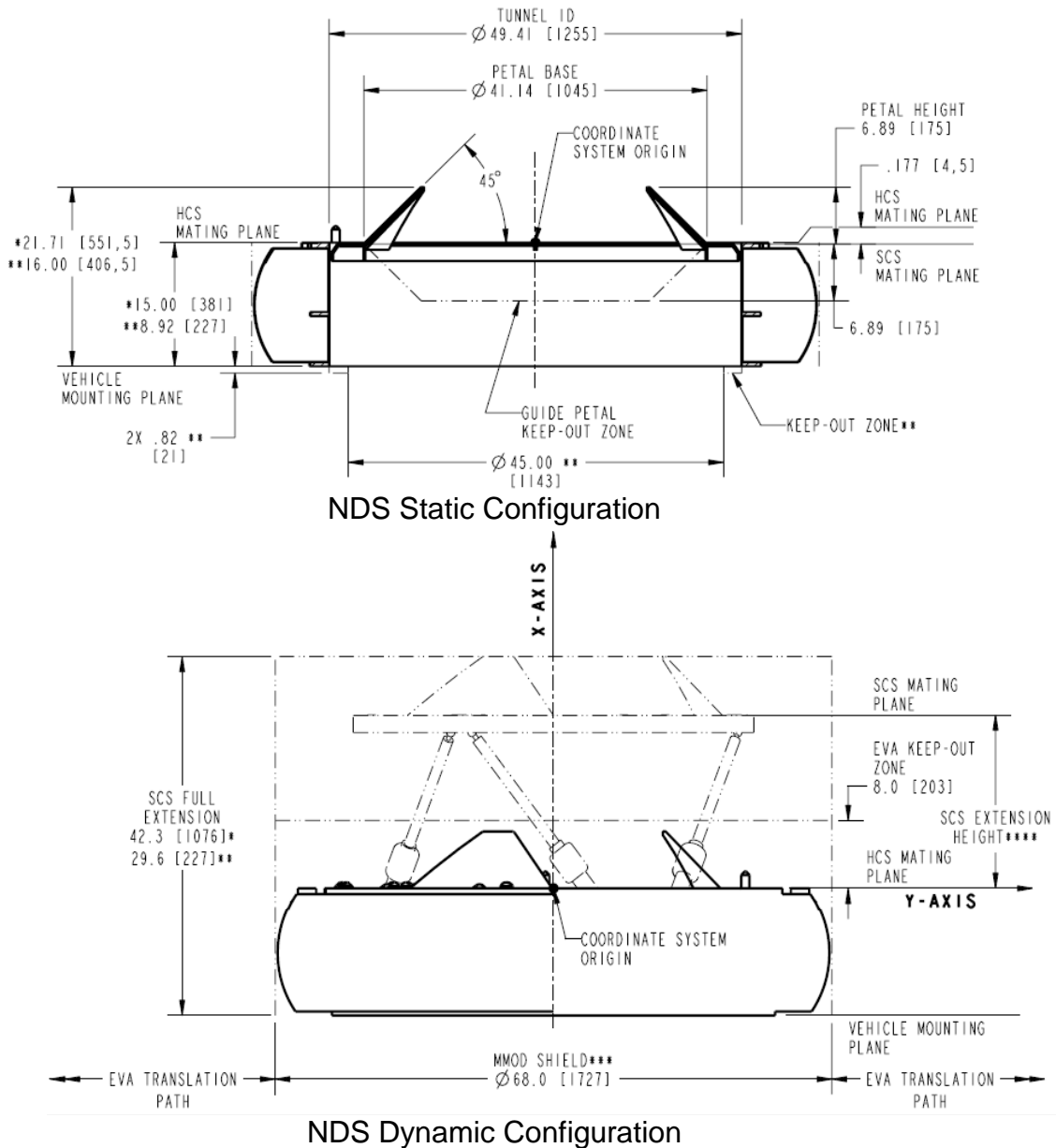

Notes:

Petals are shown symmetric about centerline for dimensioning purposes.

* Applicable for NDS (excluding -302).

** Applicable for NDS (-302).

*** Diameter dimension includes MMOD shield and TPS. Metallic MMOD shield and TPS are not supplied for NDS (-302).

**** SCS extension height:

Maximum extension = 20.63 [524]-

Ready-to-dock extension = 14.00 ± 1.0 [457 ± 25] (TBR-41)

Figure 4-3: NDS Cross Section [R.LIDS.5003]

4.1.1 Thermal Interface

The thermal environments and analysis approach is documented in JSC-65970, iLIDS Thermal and Induced Environments.

The thermal contact conductance across the NDS-to-NDS docking interface is defined as ranging from 15 Btu/hr-ft²-°F (85 W/m²-K) to 50 Btu/hr-ft²-°F (284 W/m²-K) for the metal-to-metal contact area [R.LIDS.5004].

The NDS utilizes heaters to condition/maintain temperatures above the minimum limits for each operating mode.

The allowable NDS-to-NDS interface acceptance temperature ranges for each operating condition are defined in the following sections.

4.1.1.1 Non-Operational Survival

The following applies when the docking system is unmated under non-operational conditions. Only heaters are active at this point.

-65 °F to +192 °F (-54 °C to +89 °C) [R.LIDS.5039]

Minimum – The defined minimum interface temperature of -65 °F (-54 °C) is based on heater capability. The NDS heaters can maintain the temperatures of the NDS components above their minimum survival limits when used in the environments defined in JSC-65970, iLIDS Thermal and Induced Environments.

Maximum – The defined maximum interface temperature of +192 °F (+89 °C) is the lowest maximum acceptance level temperature limit for the NDS hardware.

Warning: Unmated NDSs in solar inertial attitudes with the NDS facing the sun are known to cause violations of operational and survival limits. In these attitude/configuration conditions, time constraints will be imposed to protect the NDS. Refer to JSC-65978, iLIDS Thermal Data Book.

4.1.1.2 Operational

This section defines operational limits for the NDS. Individual components have capabilities outside these ranges. Specific component allowable limits will be defined in JSC-65978, iLIDS Thermal Data Book.

4.1.1.2.1 Tunnel and Seal Mating Interface

The following applies to the docking system (excluding the SCS) when the system is preparing to dock up through hard mate but prior to pressurization.

-38 °F to +122 °F (-39 °C to +50 °C) [R.LIDS.1051]

Minimum – The minimum interface temperature of -38 °F (-39 °C) is defined by the minimum acceptance level seal operational temperature limit.

Maximum – The maximum interface temperature of +122 °F (+50 °C) is defined by the maximum acceptance level seal operational temperature limit.

4.1.1.2.2 Soft Capture Mating Interfaces

The following applies to soft capture components when the system is preparing to dock up through hard mate but prior to pressurization.

-65 °F to +165 °F (-54 °C to +74 °C) [R.LIDS.5005]

Minimum – The minimum interface temperature of -65 °F (-54 °C) is defined by the minimum acceptance level limit switch operational temperature limit.

Maximum – The maximum interface temperature of +165 °F (+74 °C) is defined by the maximum acceptance level load cell operational temperature limit.

4.1.1.2.3 Sealing Surfaces at Mating

The following applies as the two hard mate interfaces engage from ready-to-hook through hard mate.

The acceptance level seal operational temperature limits are defined as -38 °F to +122 °F (-39 °C to +50 °C) [R.LIDS.5006]. However, the allowable temperature differential between the sealing interfaces during docking hard capture may be restricted. If the temperatures are not within the defined boundaries, a thermal hold prior to hard latching is required until the temperature requirements are satisfied. Figure 4-4: NDS Mating Interface Allowable Thermal Differential for Hard Capture [R.LIDS.5007] defines the boundaries of acceptable temperature regions for hard capture of for the two mating interfaces.

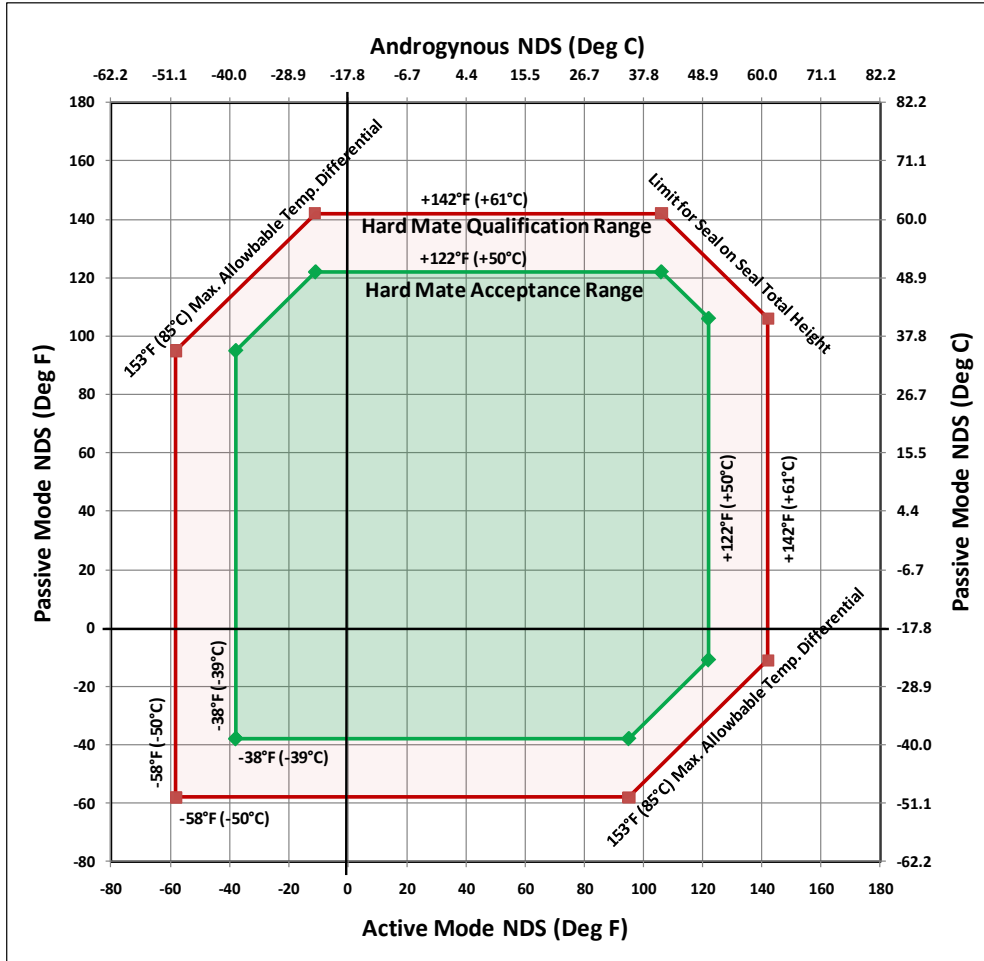

Figure 4-4: NDS Mating Interface Allowable Thermal Differential for Hard Capture [R.LIDS.5007]

4.1.1.3 Mated and Pressurized

The following is the steady state temperature range after hard mate and pressurization. The time allowable to achieve this steady state temperature is 8 hours. Analysis has shown that after hard mating, it can take as long as 8 hours in a cold environment for an NDS to warm up to the minimum dew point temperatures when starting from the minimum allowable operating temperatures. This warm up profile is shown in Figure 4-5: NDS Post Hard Mate Warm Up Profile. This does not restrict pressurization or hatch opening, but it would result in condensation within the vestibule during this transition period.

The length of time could be reduced by changing the NDS heaters to the mated/pressurized setpoints prior to hard mate. This will heat the NDS above minimum operating temperatures. In this operation, the temperatures achieved prior to mating are dependent on environment, heater power, and the time duration between setpoint change and hard mating.

Dew Point < Min °F to +113 °F (min °C to +45 °C) [R.LIDS.1051]

Minimum – The minimum temperature may be specified by the host vehicle and the docking system setpoint will be adjusted accordingly. The docking system assumes the host vehicle minimum temperature is set above the dew point.

Maximum – The maximum temperature of +113 °F (+45 °C) is defined by the barehanded touch temperature limit.

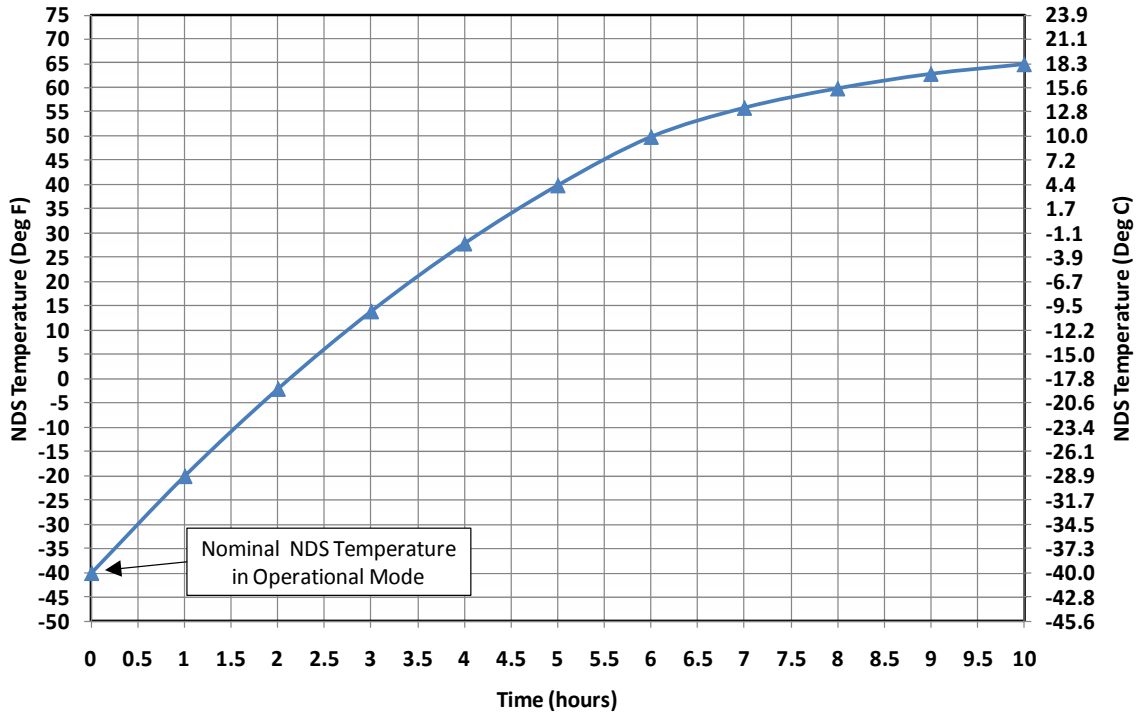
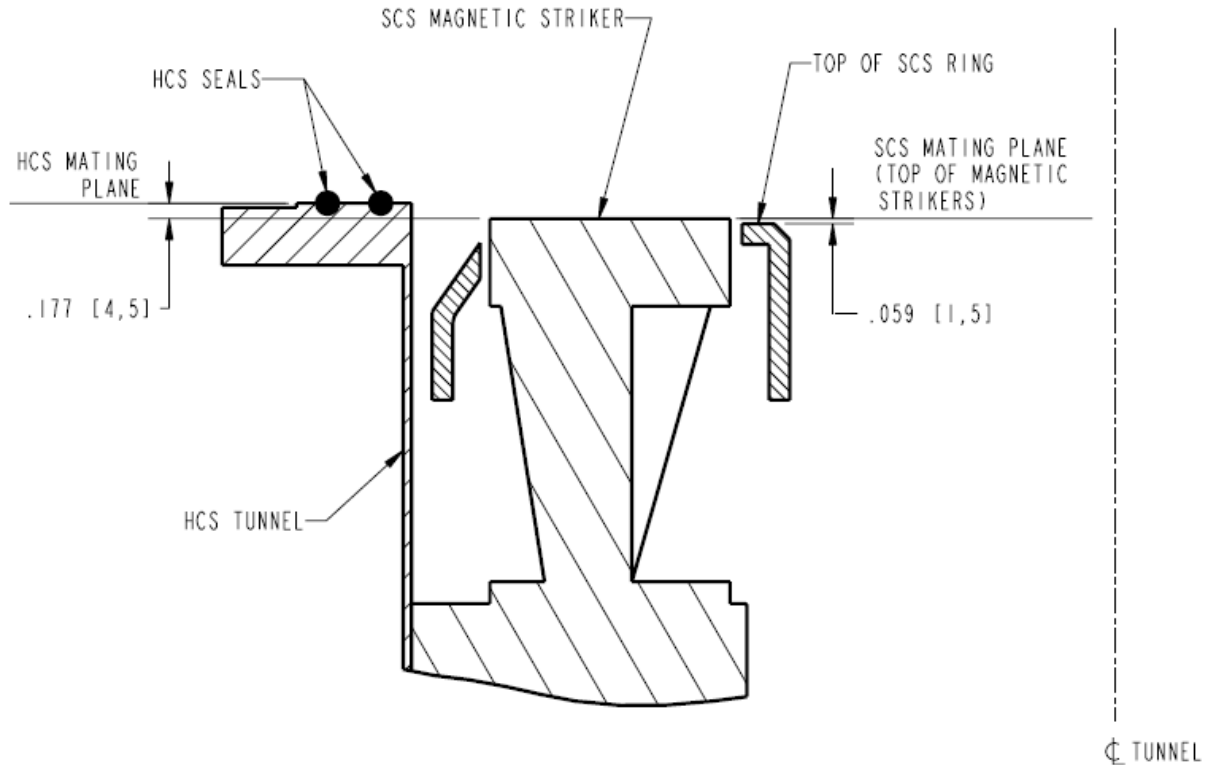

Figure 4-5: NDS Post Hard Mate Warm Up Profile

4.1.2 Soft Capture System

The NDS performs soft capture using electromagnets and magnetic striker plates. The passive mode NDS will also be scarred for future implementation of an SCS mechanical latch striker interface, which would allow an NDS-compatible docking system, using passive SCS mechanical latch striker, to capture. Soft capture is not structural mating, but the first level of attachment in the docking sequence.



Note: Configuration shown is not applicable for NDS (-304).

Figure 4-6: NDS Capture Ring in Passive Mode [R.LIDS.5008]

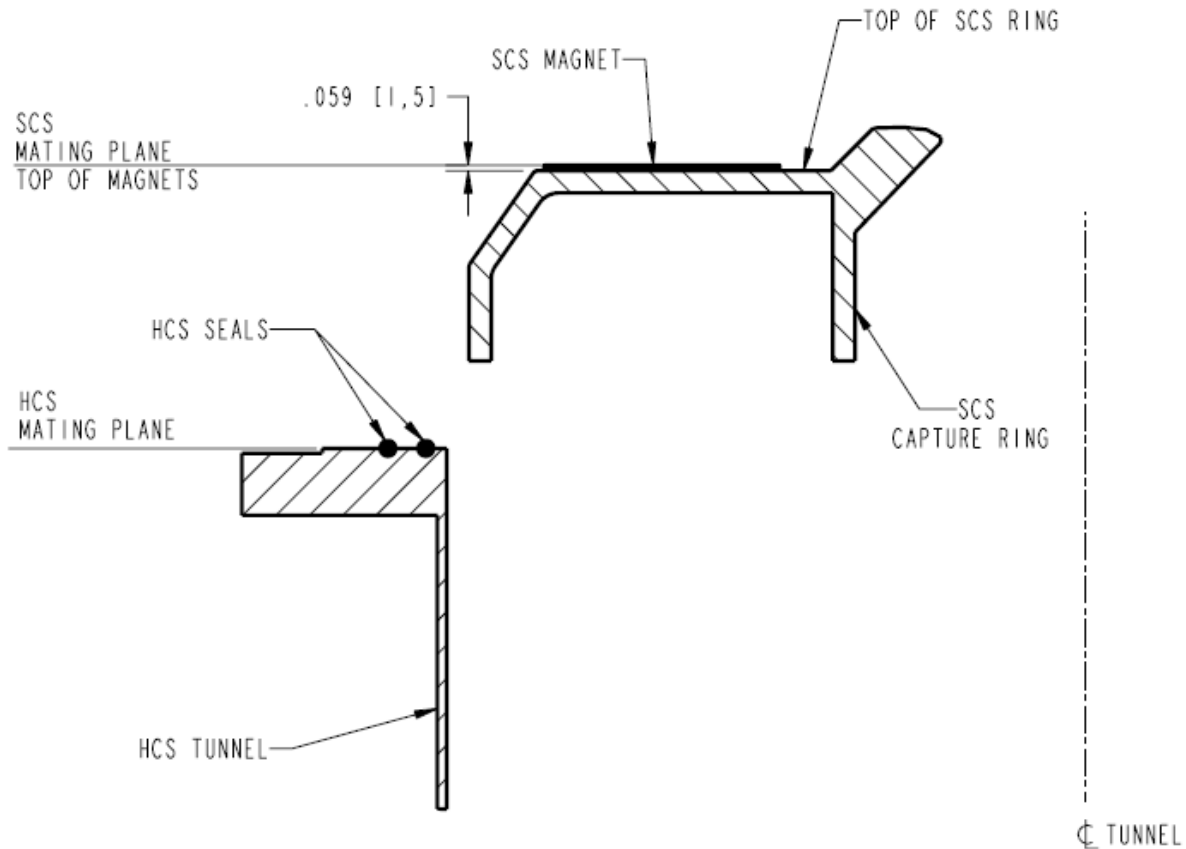

Figure 4-7: NDS Capture Ring in Active Mode [R.LIDS.5009]

4.1.2.1 Guide Petal System

There are three guide petals that mount to the soft capture ring and face inward. The petals are equally spaced around the circumference of the soft capture docking ring. A representative depiction of the guide petal layout can be seen in Figure 4-8: SCS Guide Petal System [R.LIDS.5010], Figure 4-9: SCS Guide Petal System Detail [R.LIDS.5011] and Figure 4-10: SCS Guide Petal System Profile [R.LIDS.5012]

The guide petals are Intravehicular Activity (IVA) removable. Refer to Figure 4-11: Guide Petal Removal – IVA Interface for details. For guide petal IVA removal/installation procedure, refer to SKZ29101796.

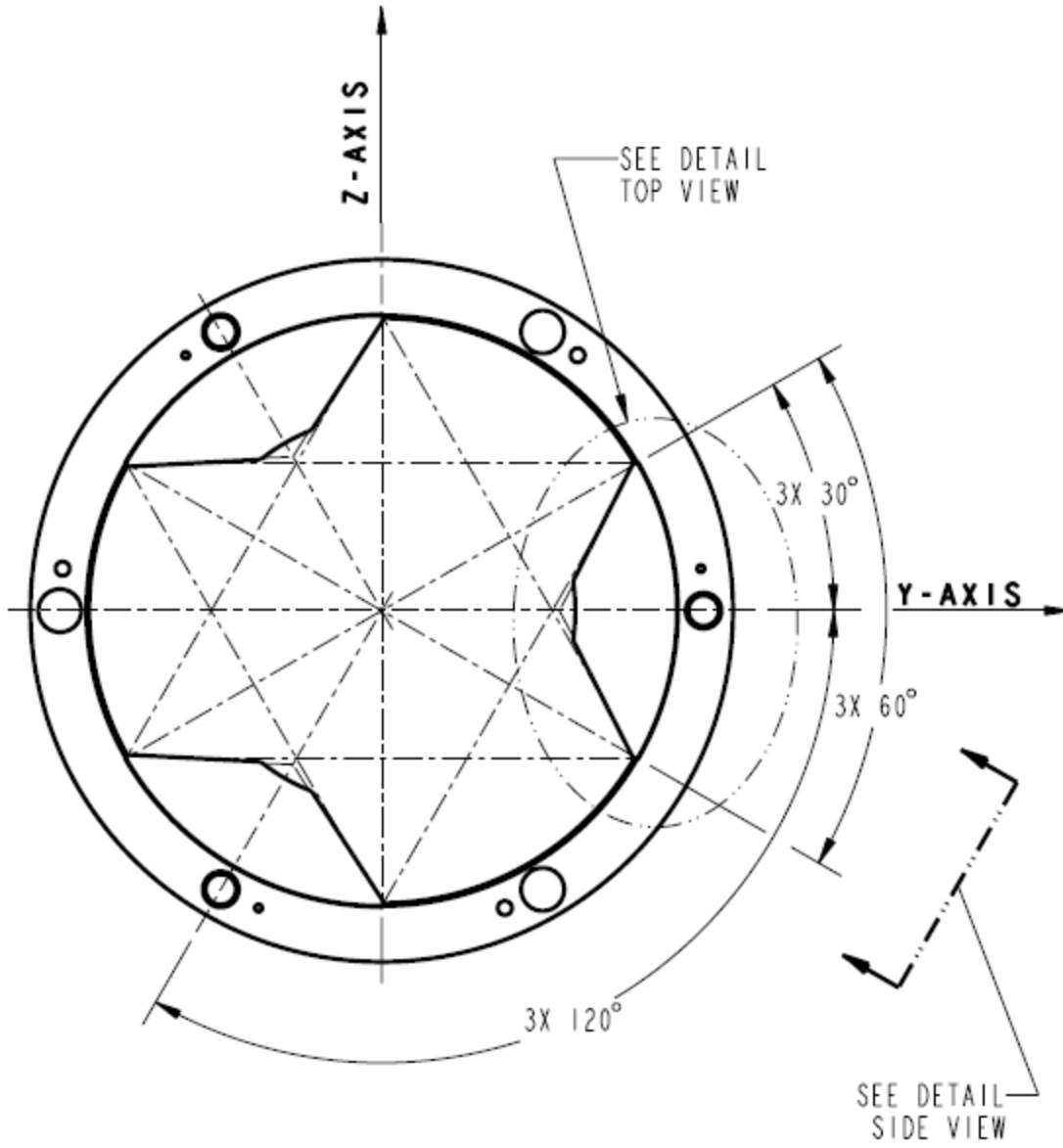
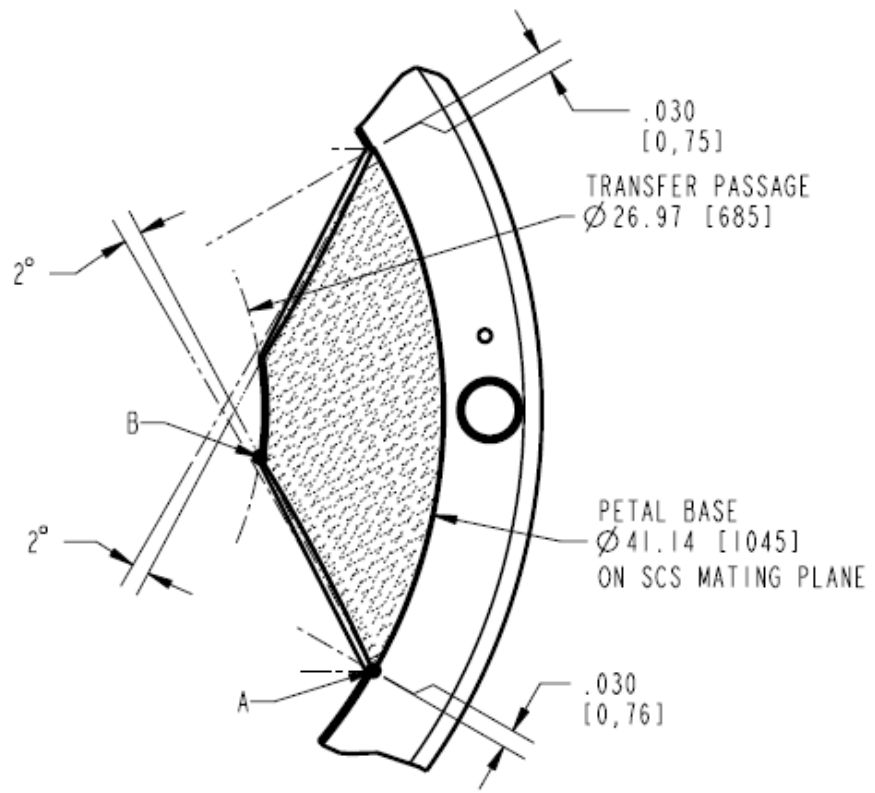
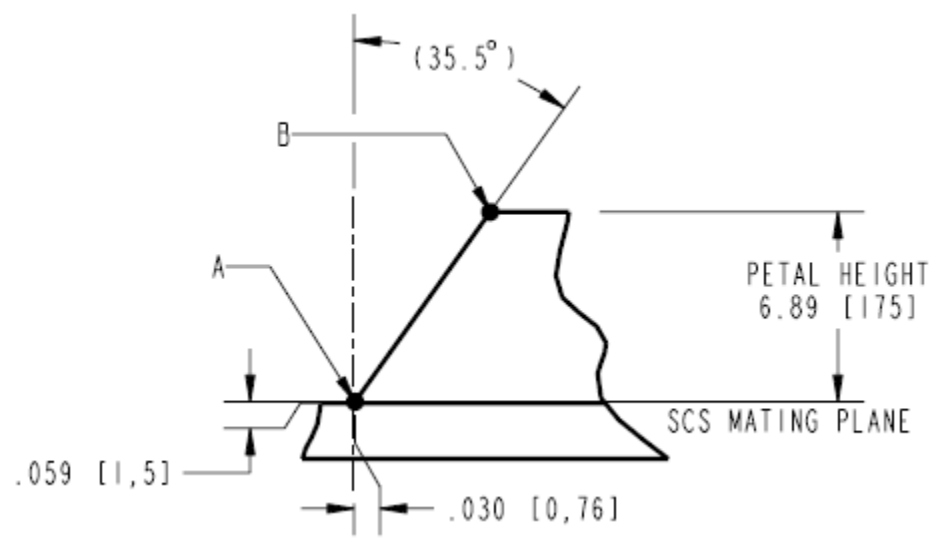

Figure 4-8: SCS Guide Petal System [R.LIDS.5010]



Detail Top View



Detail Side View

Figure 4-9: SCS Guide Petal System Detail [R.LIDS.5011]

4.1.2.2 Soft Capture Ring

The SCS ring dimensions are defined in Figure 4-10: SCS Guide Petal System Profile [R.LIDS.5012]

The SCS ring in passive mode is located as depicted in Figure 4-6: NDS Capture Ring in Passive Mode [R.LIDS.5008]. The SCS ring in active mode is actuated above the mating plane for soft capture as depicted in Figure 4-7: NDS Capture Ring in Active Mode [R.LIDS.5009].

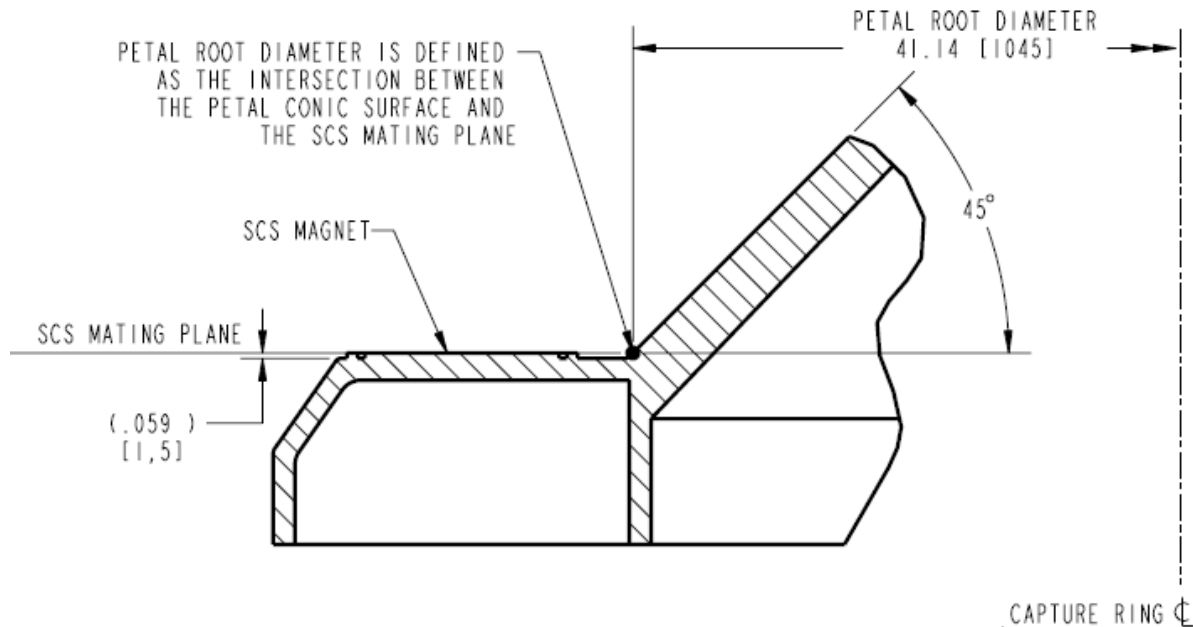

Definition of SCS Mating Plane (Page 1 of 3)

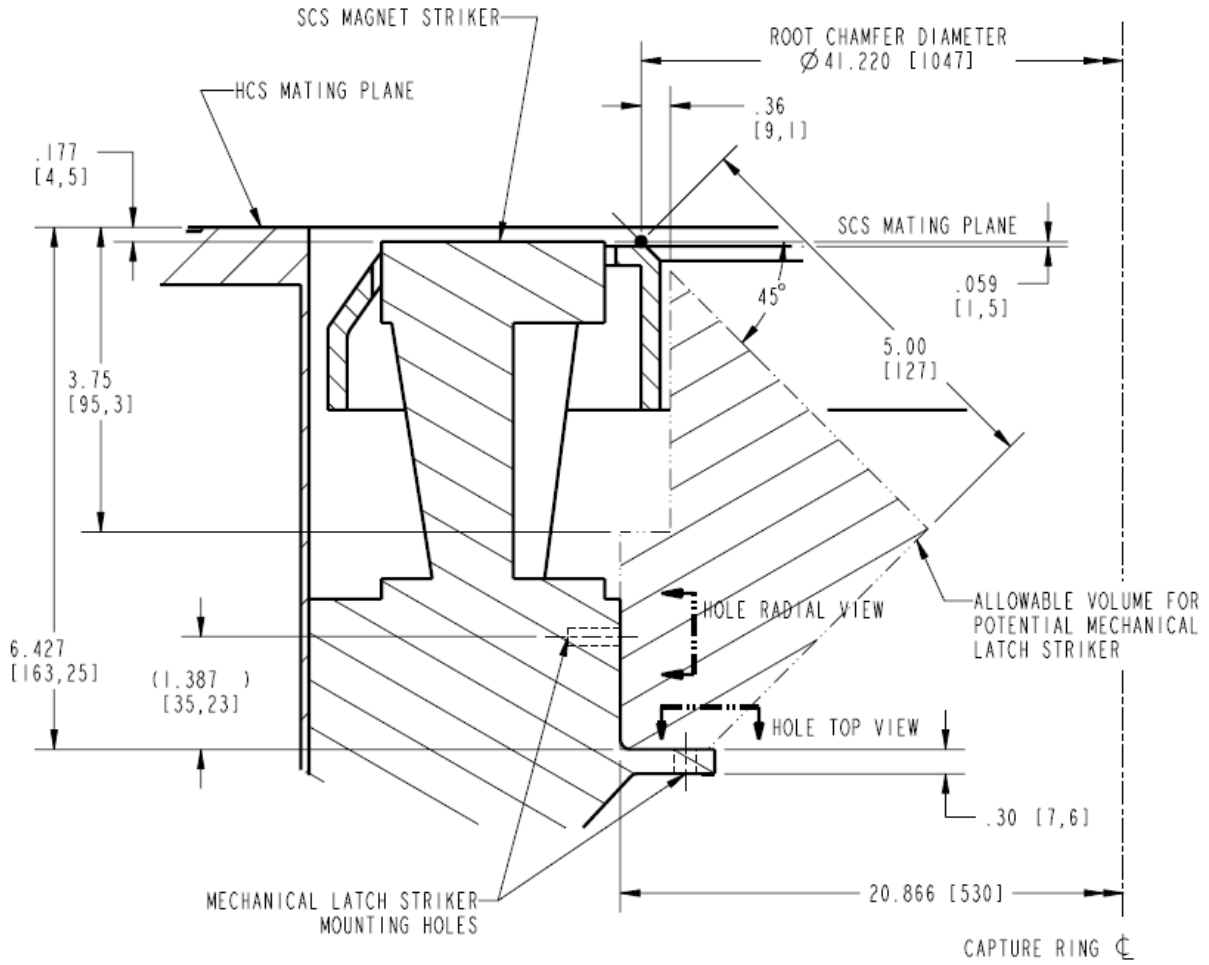

Potential Mechanical Latch Striker Interface (Page 2 of 3)

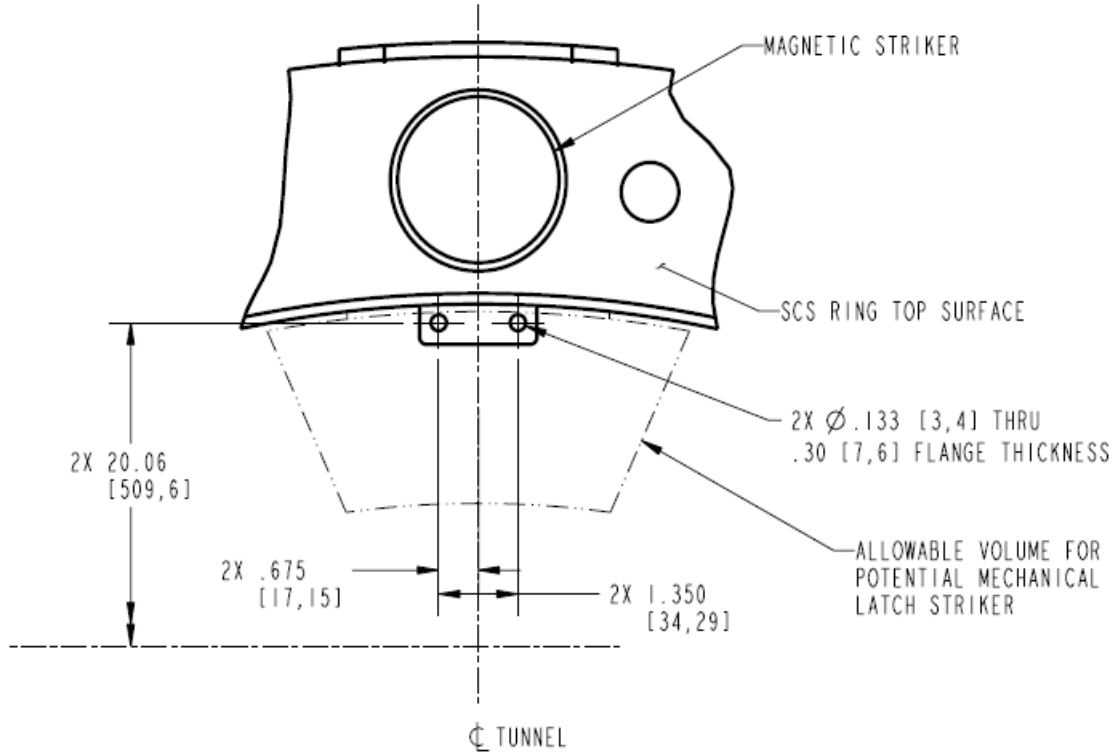

Mechanical Latch Striker Mounting Hole Top View

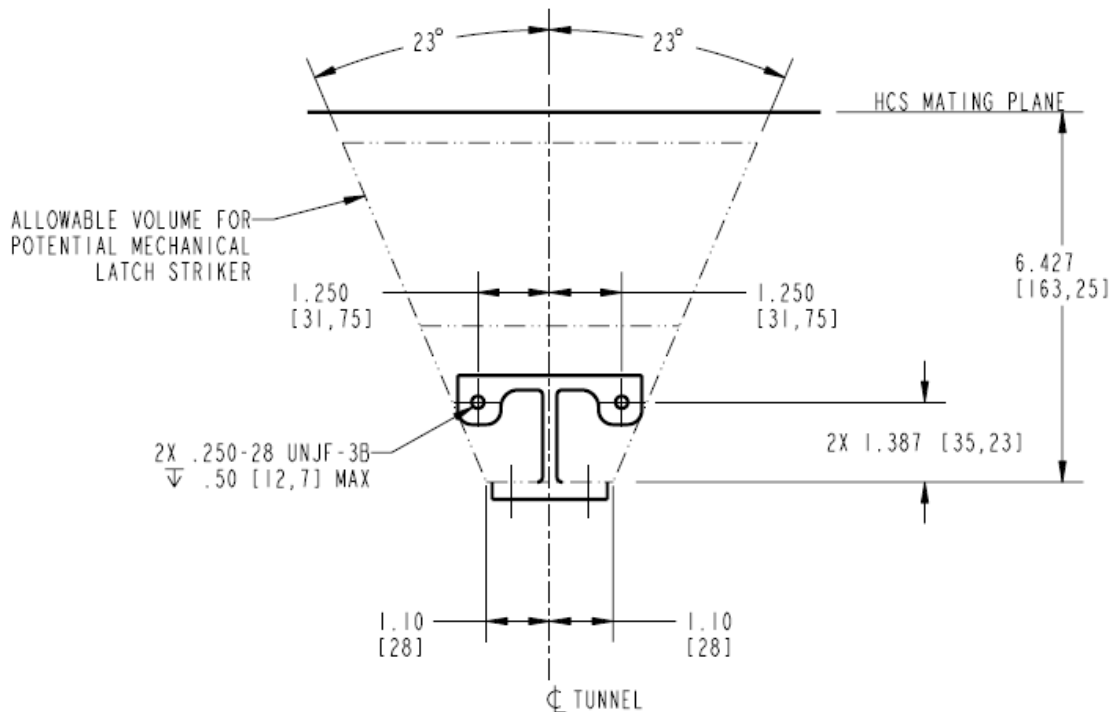

Mechanical Latch Striker Mounting Hole Radial View (Page 3 of 3)

Figure 4-10: SCS Guide Petal System Profile [R.LIDS.5012]

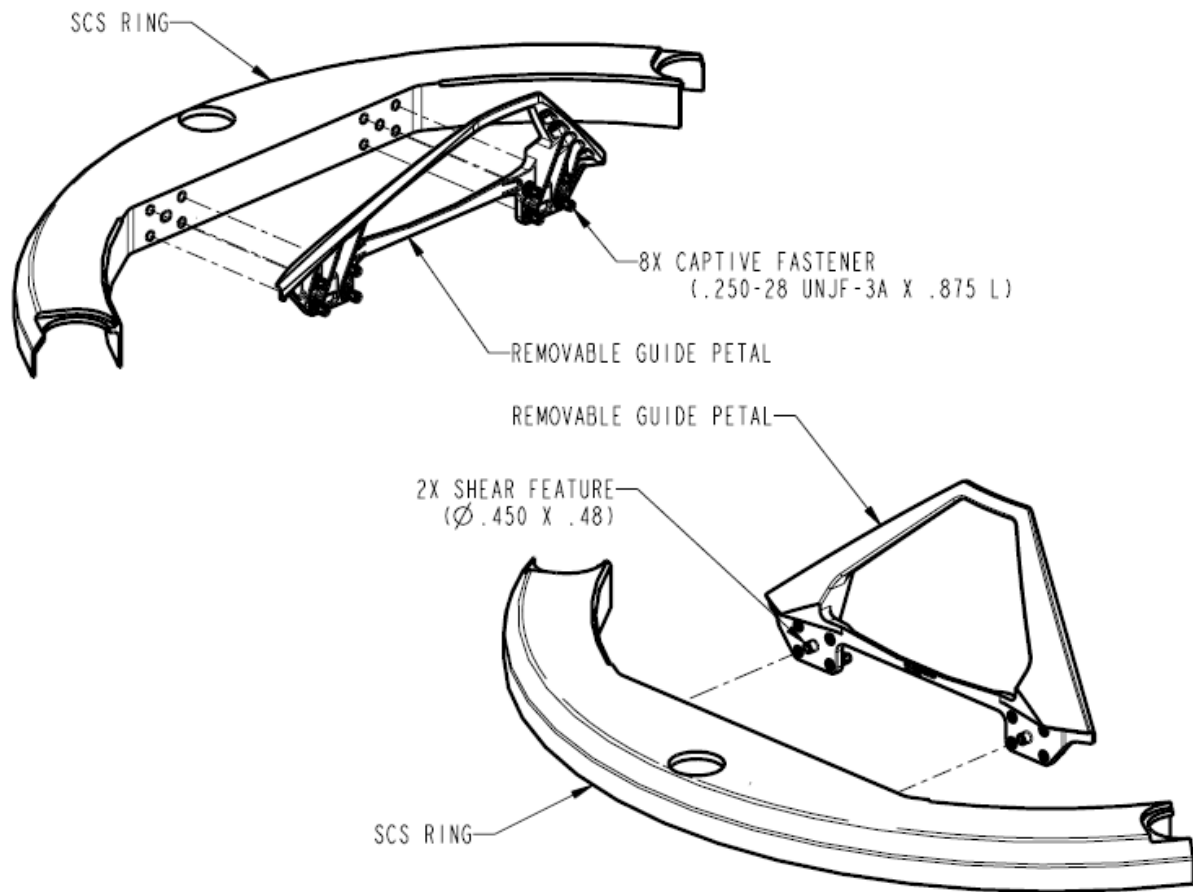
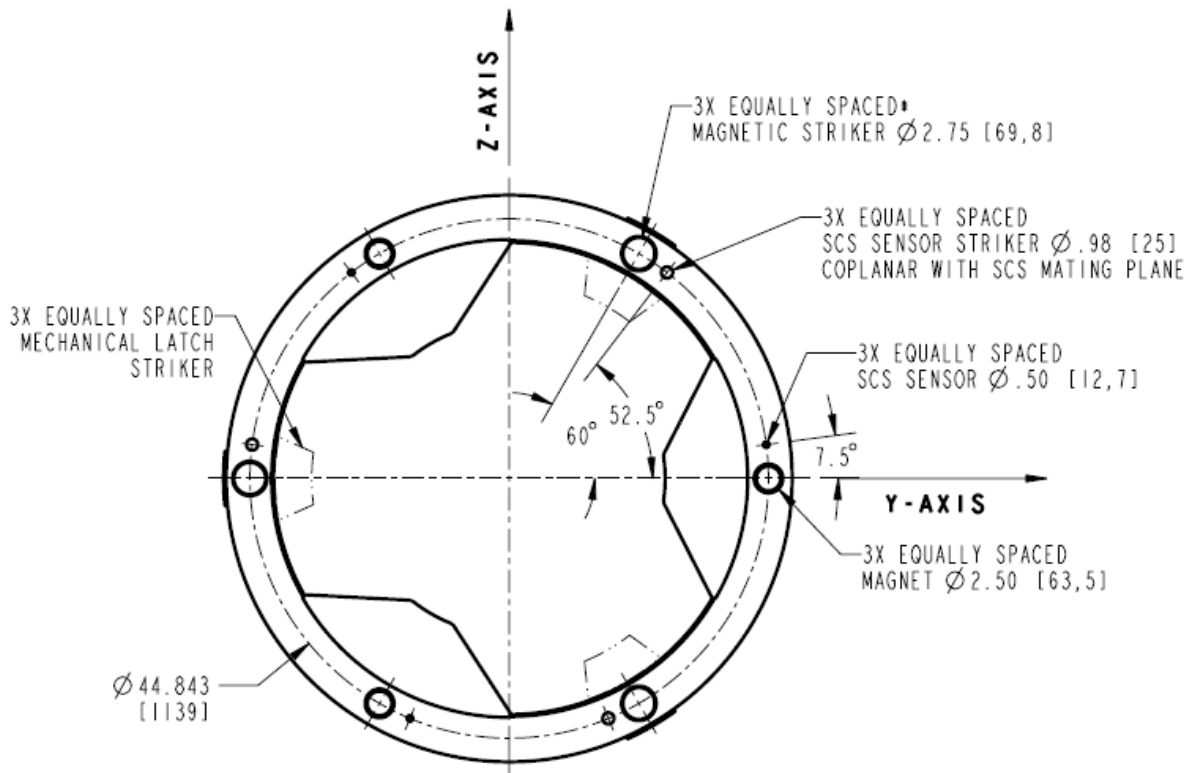

Figure 4-11: Guide Petal Removal – IVA Interface

4.1.2.3 Magnet and Striker

The SCS employs three magnets and three striker plates distributed across the soft capture ring, as defined in Figure 4-12: SCS Magnetic Capture System [R.LIDS.5013]. Per this figure, the three striker plates across the soft capture ring are not applicable for the NDS (-304). The SCS striker in passive mode elevation relative to the SCS ring must be as depicted in Figure 4-6. The SCS striker in active mode elevation relative to the SCS ring must be as depicted in Figure 4-7.



Note: *Not applicable for NDS (-304).

Figure 4-12: SCS Magnetic Capture System [R.LIDS.5013]

4.1.2.4 Soft Capture Sensors and Strikers

The SCS of the docking system provides an indication when the two SCS mating planes become co-planar through the use of limit switch sensors. These switches trigger the energization of the electromagnets, which creates the soft capture holding force. The NDS has three soft capture indication locations, located at an offset from the magnet/striker centerline as defined in Figure 4-12.

4.1.2.5 Pre-Capture SCS Compressive Force Resistance

The low impact technology SCS requires minimal compressive force resistance across the interface prior to capture. In order to achieve soft capture, a maximum of 10 lb compressive force resistance is allowed across the interface. This means each side is allowed to have a maximum of 5 lb resistance. This resistance might

include magnet strikers compliance mechanism, the SCS capture sensors, and any other sources of compressive force resistance [R.LIDS.5014].

4.1.2.6 SCS Mechanical Latch Striker

All NDS configurations have reserved volume for potential implementation of SCS mechanical latch strikers, which would allow other IDSS-compatible docking systems that use SCS mechanical latches to dock to NDS. This is not structural mating, but the first level of attachment. All NDS configurations have reserved the volume defined in Figure 4-10 located as depicted in Figure 4-2.

4.1.2.7 Capture Envelope

See Table 4-1: NDS Initial Contact Conditions “Design To” Limits⁽¹⁾⁽²⁾⁽³⁾⁽⁴⁾.

Table 4-1: NDS Initial Contact Conditions “Design To” Limits⁽¹⁾⁽²⁾⁽³⁾⁽⁴⁾⁽⁵⁾ [R.LIDS.0063]

Initial Conditions	Limiting Value
Closing (axial) rate	0.05 to 0.15 ft/s (0.015 to 0.045 m/s)
Lateral (radial) rate	0.15 ft/sec ⁽⁴⁾ (0.045 m/s)
Angular rate	0.15 deg/sec about NDS X axis; vector sum of 0.15 deg/sec about NDS Y and Z axes
Lateral (radial) misalignment	4.2 ± .125 inches [106 ± 3 mm]
Angular misalignment	4.0 ± .25 degrees about NDS X axis; vector sum of 4.0 ± .25 degrees about NDS Y and Z axes

Notes:

- (1) Initial conditions to be applied simultaneously.
- (2) The NDS will use a right-hand orthogonal body coordinate system, the origin of which lies in the intersection of the NDS cylindrical center line X-axis and HCS mating plane (refer to Figure 4-3).
- (3) These initial conditions are applicable for the docking of a chaser host vehicle with a mass of at least 1000 slugs (15000 kg), but no greater than 1700 slugs (25000 kg), to a target vehicle with a mass of at least 24000 slugs (350000 kg). It is assumed the chaser host vehicle has no lateral center of gravity offset.
- (4) Lateral (radial) rate limit includes combined lateral and rotational rates of both vehicles.
- (5) In order to achieve capture with these initial conditions, it may be necessary for Post Contact Thrust (PCT) firing with TBD-46 properties.

4.1.3 Hard Capture System

The HCS facilitates a hard capture (i.e., when two vehicles are structurally mated, sealing is complete, and the vestibule is ready for pressurization and hatch opening).

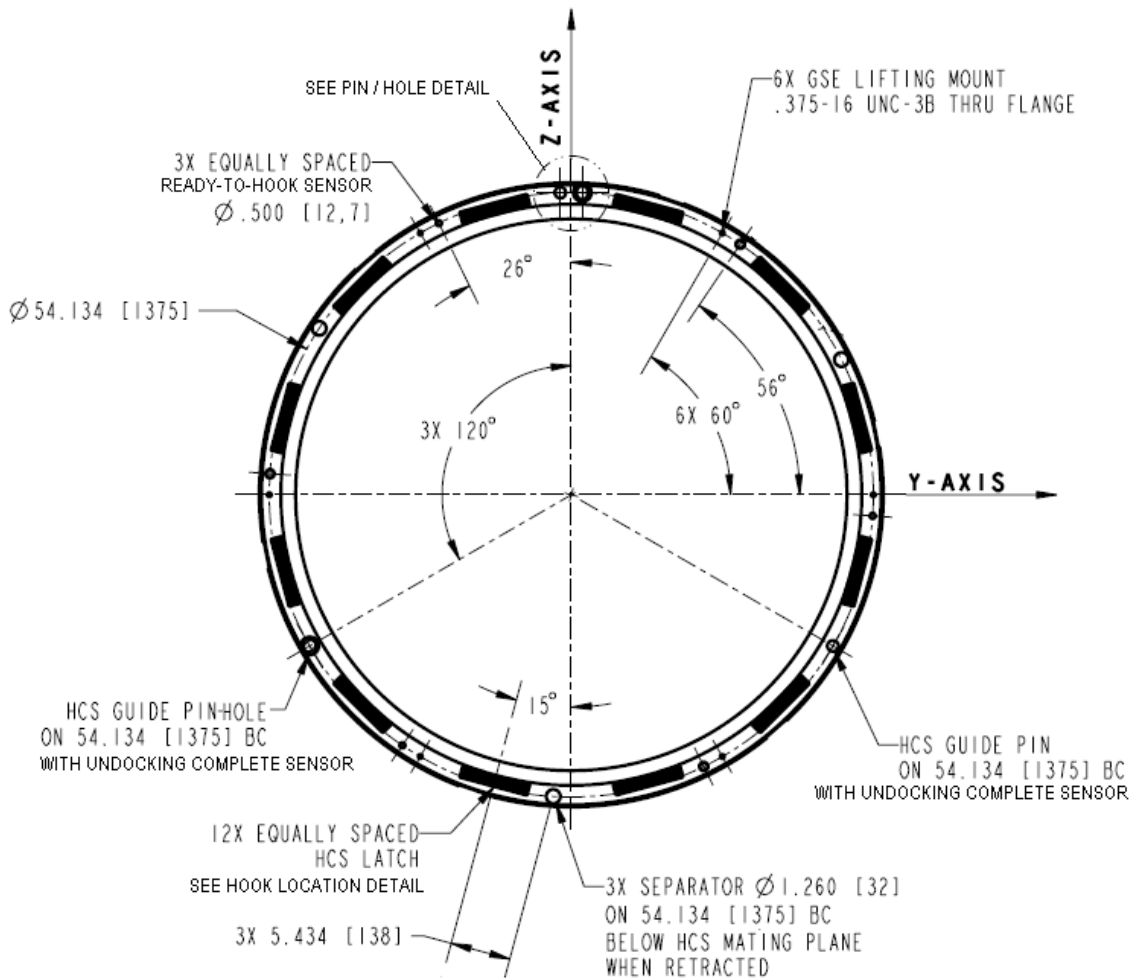

HCS Component Interface Definition (Page 1 of 2)

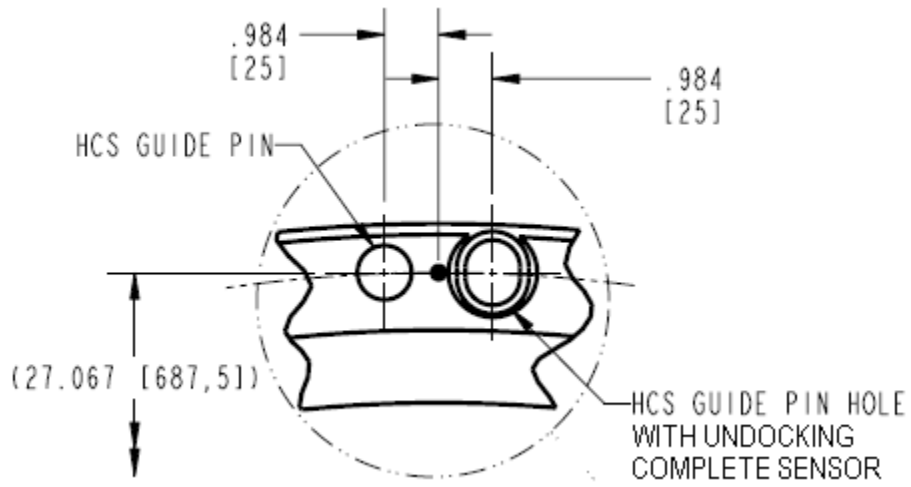

Pin / Hole Detail

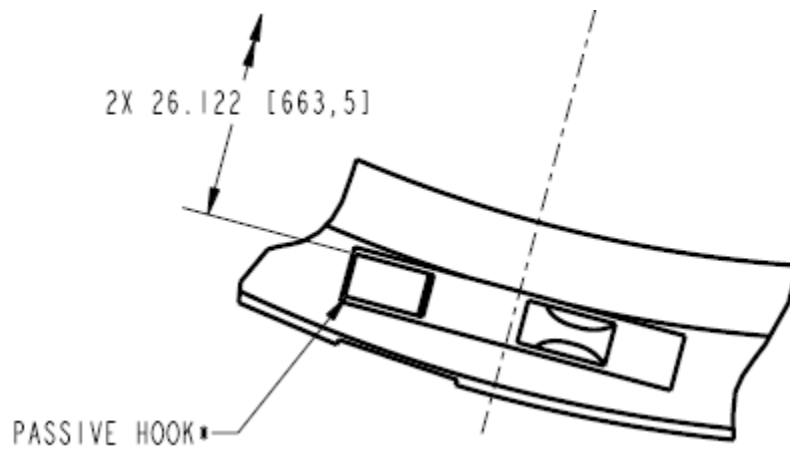

Hook Location Detail
(Page 2 of 2)

Note: *Not applicable for NDS (-304).

Figure 4-13: HCS Docking Interface [R.LIDS.0029]

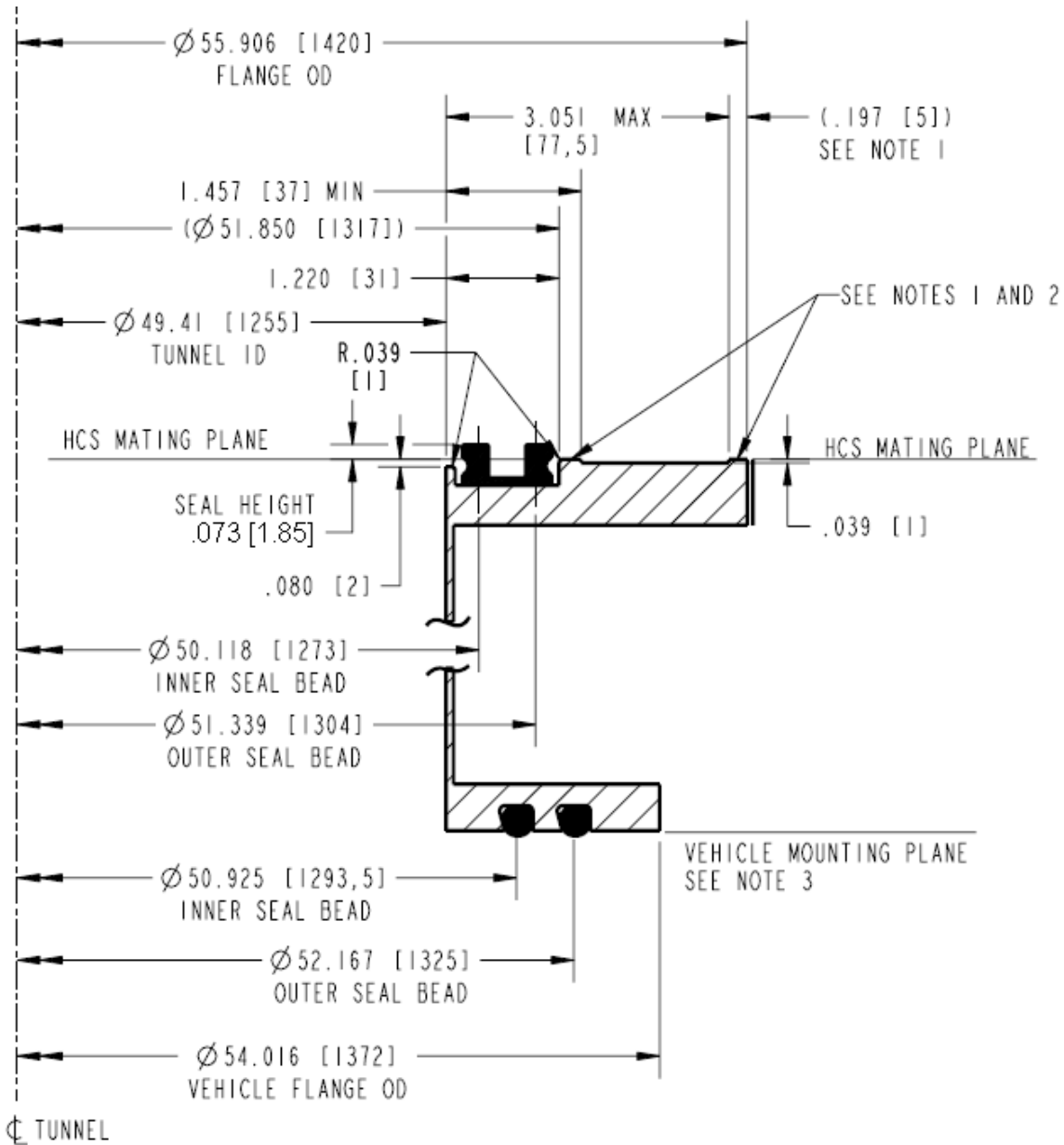

Notes:

- (1) Chemical conversion coat per MIL-DTL-5541, TYPE 1, Class 3.
- (2) Global surface flatness not to exceed .010 on indicated surface.
Local surface flatness not to exceed .003 across any area on indicated annular surface (O.D. = 54.075[1373], I.D. = 52.32[1329]) for an arbitrary 30° arc, except for the .039[1] recessed area.
- (3) Global surface flatness not to exceed .010 on indicated surface.
Local surface flatness not to exceed .003 across any area on indicated annular surface (O.D.= 54.016[1372], I.D. = 49.41[1255]) for an arbitrary 30° arc.

Figure 4-14: NDS (excluding -302) HCS Mating Plane Seal and Electrical Bonding Details [R.LIDS.5015]

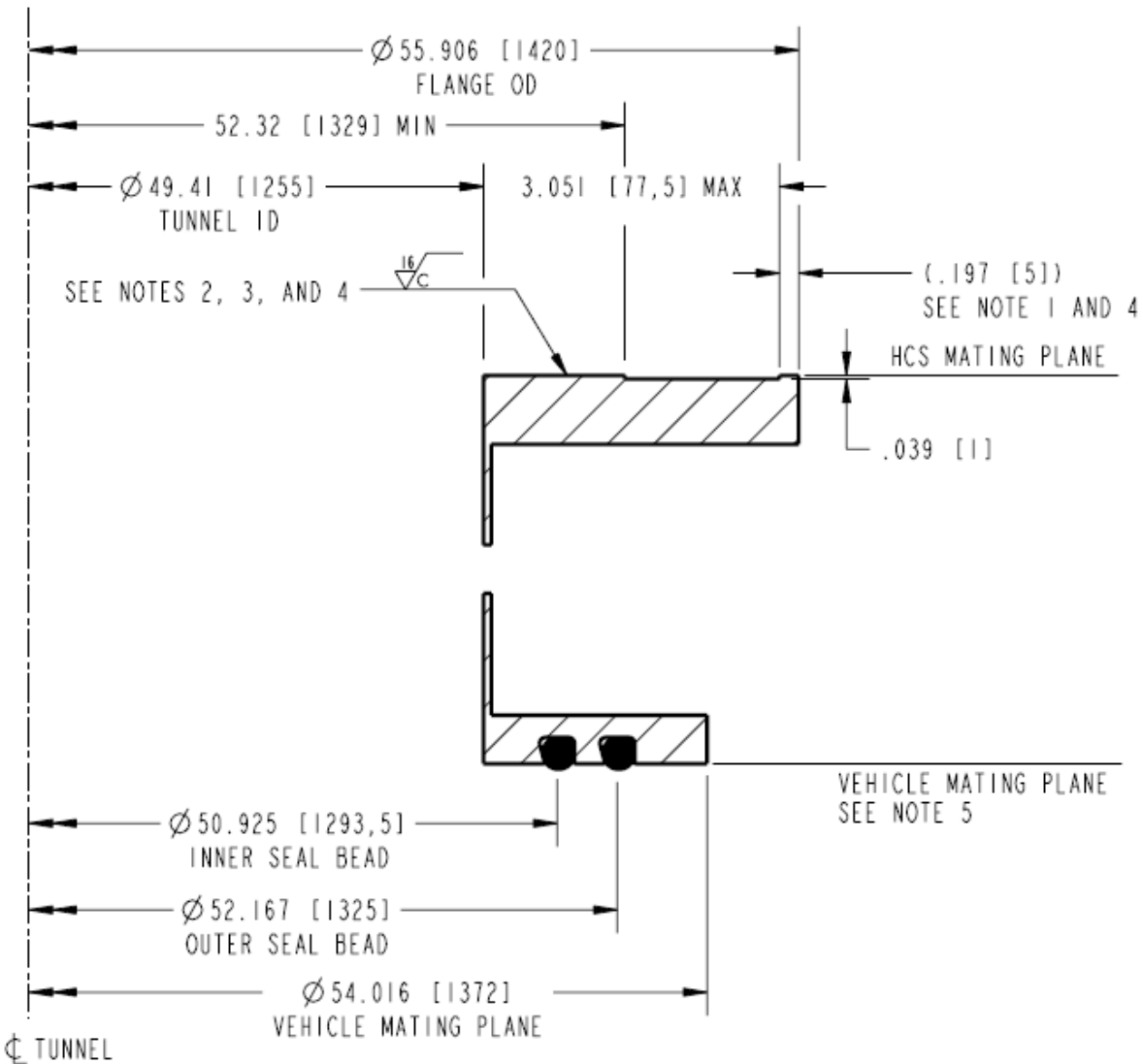

Notes:

- (1) Chemical conversion coat per MIL-DTL-5541, Type 1, Class 3.
- (2) Surface finish applicable prior to metal finish.
- (3) Anodize per MIL-A-8625, Type II, Class 1, using hot water seal.
- (4) Global surface flatness not to exceed .010 on indicated surface.
Local surface flatness not to exceed .003 across any area on indicated annular surface (O.D. = 55.906 [1420], I.D. = 49.41 [1255]) for an arbitrary 30° arc, except for the .039 [1] recessed area.
- (5) Global surface flatness not to exceed .010 on indicated surface.
Local surface flatness not to exceed .003 across any area on indicated annular surface (O.D. = 54.016 [1372], I.D. = 49.41 [1255]) for an arbitrary 30° arc.

Figure 4-15: NDS (-302) HCS Mating Plane Seal and Electrical Bonding Details
[R.LIDS.5016]

4.1.3.1 Tunnel

For tunnel interfaces refer to Figure 4-13: HCS Docking Interface [R.LIDS.0029], Figure 4-14: NDS (excluding -302) HCS Mating Plane Seal and Electrical Bonding Details, and Figure 4-15: NDS (-302) HCS Mating Plane Seal and Electrical Bonding Details.

4.1.3.2 Seal

The HCS of the NDS accommodates a seal-on-seal interface and a seal-on-metal interface with two concentric seals at specified diameters. The NDS has the pressure seal interfaces located internally with respect to the tangential hook location. For seal-on-seal interfaces refer to Figure 4-13. For seal-on-metal interfaces, refer to Figure 4-14.

4.1.3.3 Guide Pins and Receptacles

The NDS has two guide pins and two guide pin receptacles, as illustrated in Figure 4-13, for final alignment of the hard-mate interface. Refer to Figure 4-16: HCS Guide Pin Detail and Figure 4-17: HCS Guide Pin Hole Detail.

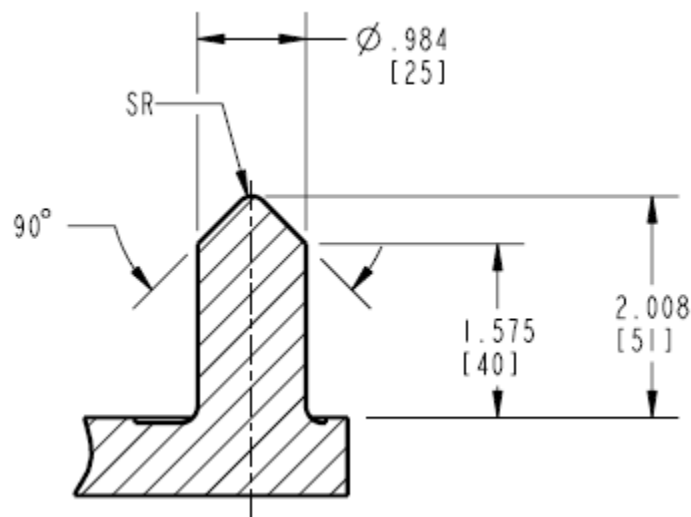

Figure 4-16: HCS Guide Pin Detail [R.LIDS.1005]

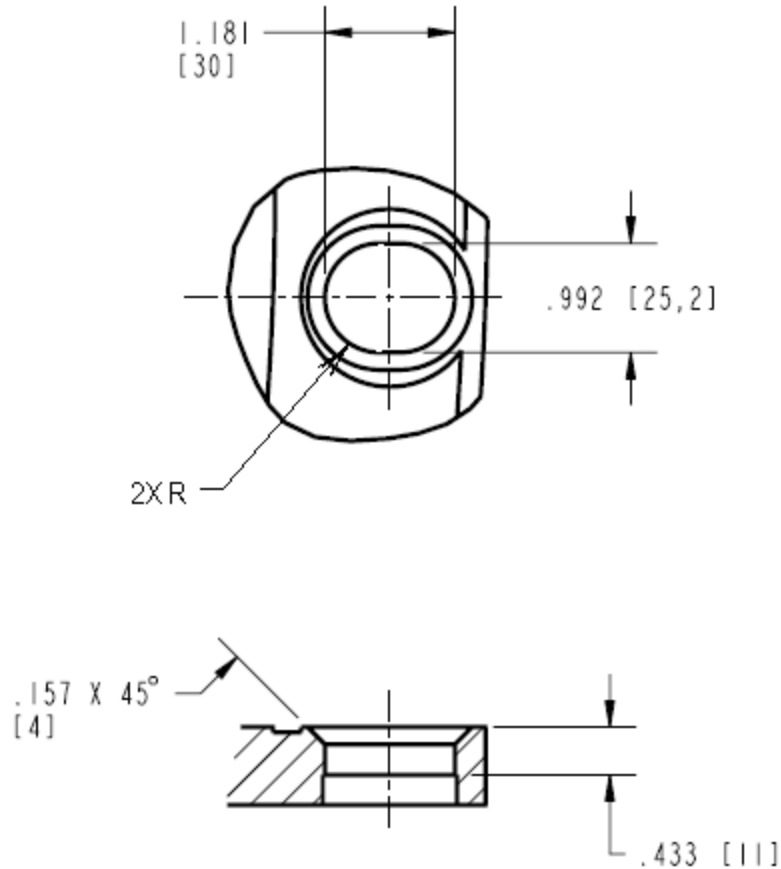
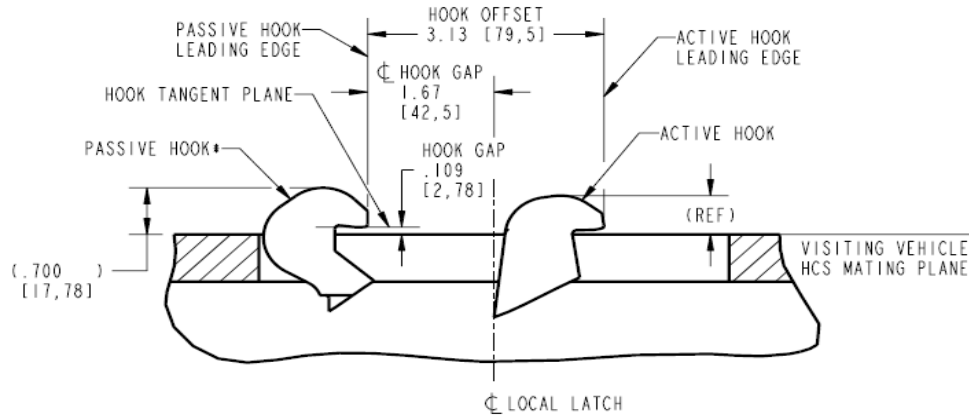

Figure 4-17: HCS Guide Pin Hole Detail [R.LIDS.1005]

4.1.3.4 Hard Capture Hooks

The NDS is configured with tangential hooks on the HCS. The NDS (excluding -304), when mated, has 24 attachment points where 12 active hooks on one system engage 12 passive hooks on the mating system to carry nominal loads. Refer to Figure 4-13. The 12 active hooks can be driven in two gangs of six that form an alternating pattern (i.e., every other hook). The -304 does not include the 12 passive hooks. Each of the 12-hook pair locations on the HCS has 1 passive and 1 active hook assembly. The NDS implements a spring-biased self-compliance passive hook between the mating active-passive hook pair. Refer to Figure 4-13, Figure 4-19, and Figure 4-20: HCS Passive Hook Detail.



Ready-To-Dock Configuration

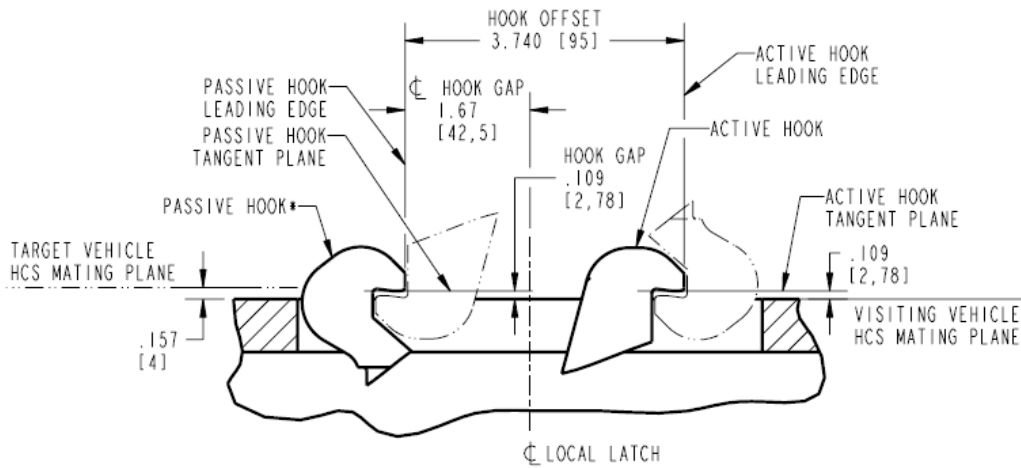

Ready-To-Hook Configuration

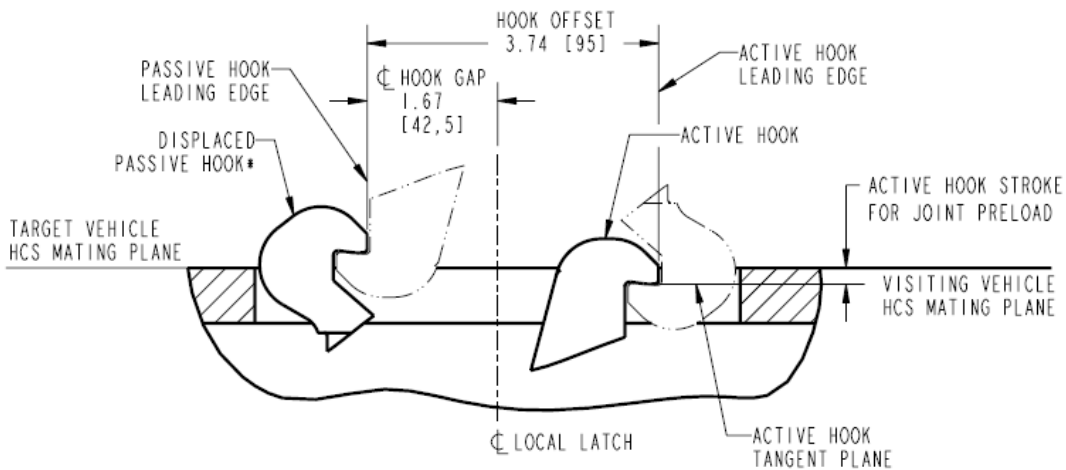

Fully Mated Configuration

Note: *Spring loaded passive hook has a minimum stroke of .315 [8]. Passive hook is excluded from NDS (-304).

Figure 4-18: HCS Hook Configurations [R.LIDS.0029]

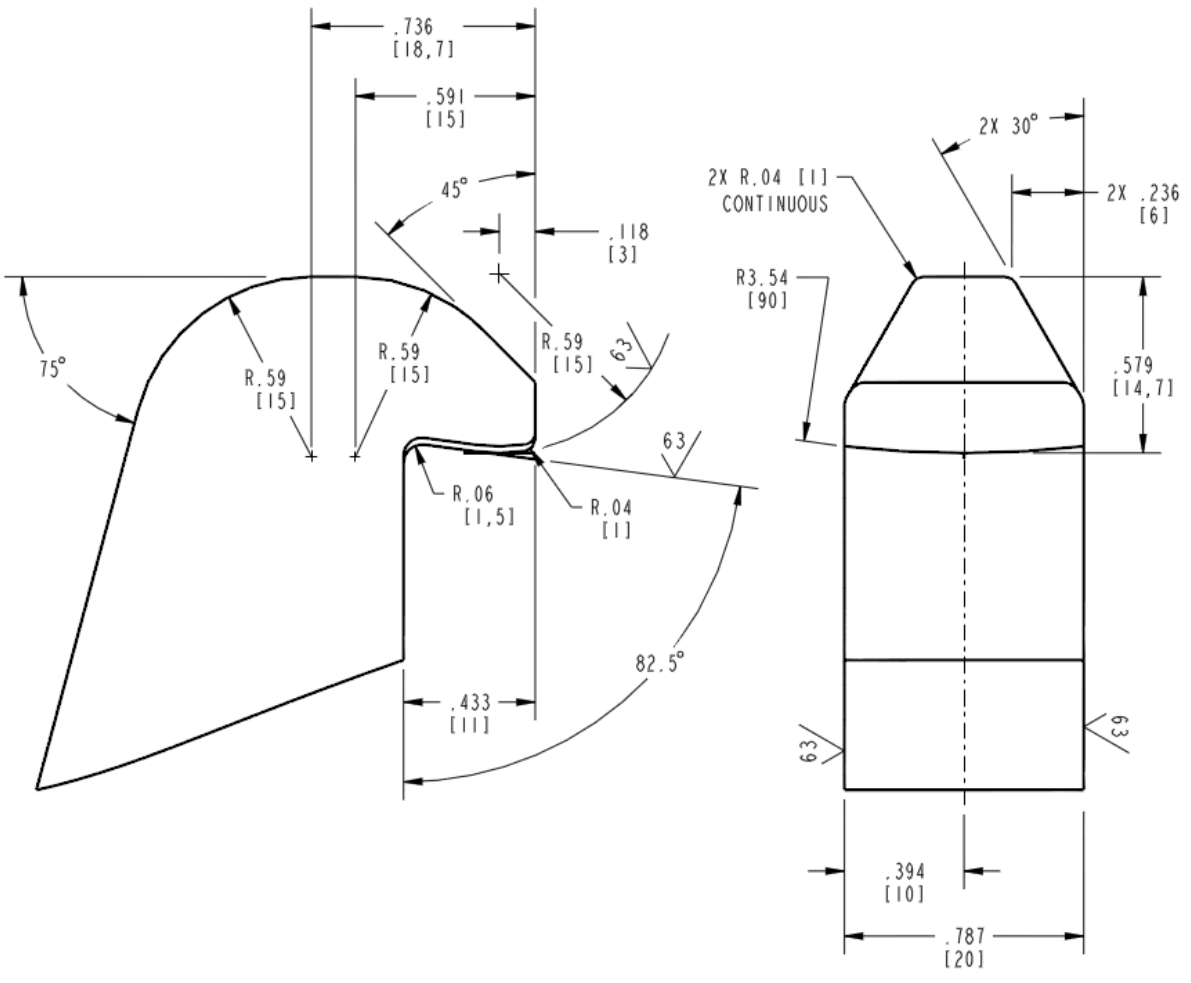

Note: See previous page for ready-to-dock, ready-to-hook, and fully mated configurations.

Figure 4-19: HCS Active Hook Detail [R.LIDS.1124]

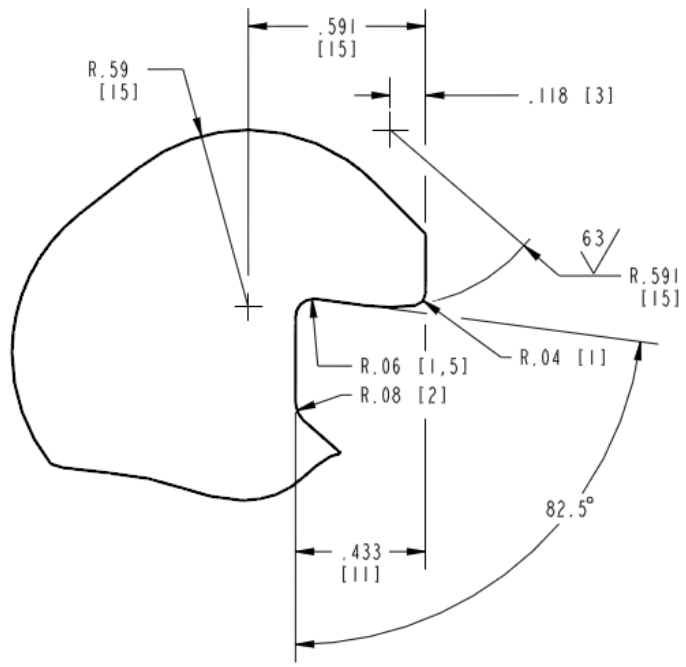
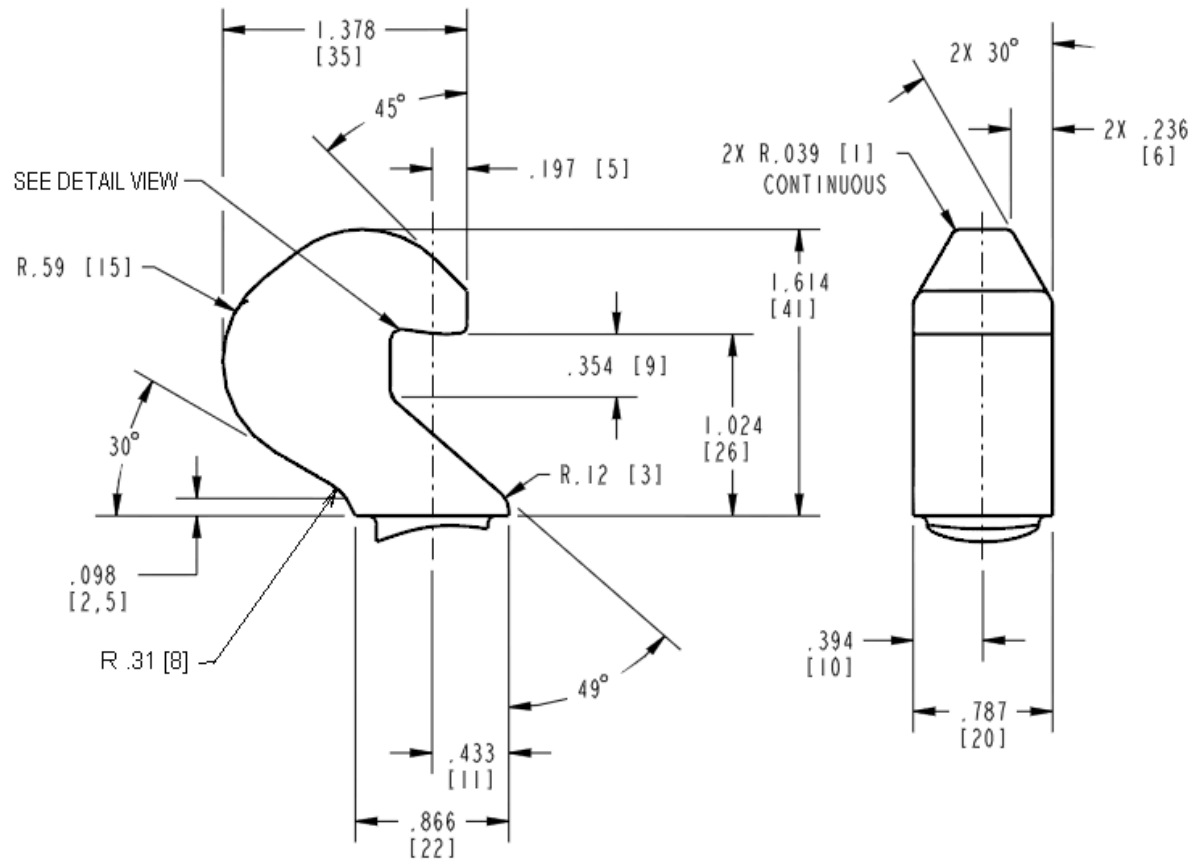

Detail View

Figure 4-20: HCS Passive Hook Detail (Excluding -304) [R.LIDS.1125]

4.1.3.5 Hard Capture Sensors and Strikers

The NDS has a Ready-to-Hook (RTH) indication capability achieved by having RTH sensors and strikers. There are three sensor and three striker locations, which reside 120 degrees from one another on the hard capture tunnel. Refer to Figure 4-13. The NDS also has hook position sensors, which indicate the active hook is fully open, fully closed, and the hook is locked in the overcenter position.

4.1.3.6 Undocking Complete Sensors and Strikers

The NDS docking system has an undocking complete indication capability achieved by having an undocking-complete sensor. There are three sensor locations that correspond to three sensor/striker locations. The three separation sensors indicate NDS approximate clearance of guide pins after the mated vehicles have been pushed apart. Refer to Figure 4-13.

4.1.3.7 Separation System

The NDS includes three separation springs recessed below the docking sealing surface that can be remotely engaged for separation and reset to a recessed position for docking. The three separation springs will induce an initial separation force of 551 lb (250 kgf) minimum and 595 lb (270 kgf) maximum [R.LIDS.5017]. To demate, the work (energy) applied will be between 28.9 ft-lb (4.0 kgf-m) and 31.1 ft-lb (4.3 kgf-m) [R.LIDS.1069]. The seal stiction and the umbilicals will be demated during separation. Refer to Figure 4-12. The initial force and work energy was sized to provide the same capability as specified in JSC-26938, Procurement Specification for the Androgynous Peripheral Docking System for the ISS Missions.

4.1.4 Loads

The NDS is capable of performing docking operations under the following load conditions, as outlined in Table 4-2: SCS Maximum Docking Loads, Table 4-3: SCS Maximum Component Loads, Table 4-4: HCS Maximum Mated Loads, and Table 4-5: HCS Mated Load Sets.

4.1.4.1 Soft Capture Docking Loads

Table 4-2: SCS Maximum Docking Loads

Tension	877 lbf	(3900 N)
Compression (Static)	787 lbf	(3500 N)
Compression (Dynamic, < 0.1 sec)	1461 lbf	(6500 N)
Shear	719 lbf	(3200 N)
Torsion	1106 lbf*ft	(1500 Nm)
Bending	2065 lbf*ft	(2800 Nm)

Table 4-3: SCS Maximum Component Loads

Mechanical Latch Striker Tension	674 lbf		(3000 N)	
Magnetic Latch Striker Tension	517 lbf		(2300 N)	
Striker Compression	674 lbf		(3000 N)	
Petal Edge Length	0%	10%	60%	80%
Petal Contact Loads	787 lbf	517 lbf	517 lbf	225 lbf
	(3500 N)	(2300 N)	(2300 N)	(1000 N)

Notes for Table 4-2: and Table 4-3::

- Loads shown in these tables are for reference only. JSC-65970, iLIDS Thermal and Induced Environments Specification is the governing document for applicable loads [R.LIDS.1069].
- Values are design limit loads.
- Values in Table 4-2 are defined at the center of the SCS mating plane. Refer to Figure 4-6 and Figure 4-7.
- Values are 3σ maxima and are to be applied simultaneously as provided in Table 4-2 such that the component values in Table 4-3 are not exceeded.
- Shear and bending loads are vector sums in the plane of the SCS mating plane. Refer to Figure 4-6 and Figure 4-7.
- The active SCS must meet all of its functional and performance requirements without exceeding loads defined in Table 4-2.
- The passive soft capture interface, or active SCS in the passive mode, must meet all of its functional and performance requirements during and after exposure to loads defined in Table 4-2 and Table 4-3.
- The petal contact load is applied to the edge of the petal or the outer face of the petal. The load can only be applied to the petal edge from the root of the petal to 80% of the petal length. The load can only be applied to the outer face from the root of the petal to 60% of the petal length from the base.

4.1.4.2 Hard Capture Mated Loads

Table 4-4: HCS Maximum Mated Loads

	Mated ISS	Trans-Lunar
Maximum Design Pressure	15.95 psi (1100 hPa)	0 psi (0 hPa)
Seal Closure Force	137 lbf/in (24 000 N/m)	137 lbf/in (24 000 N/m)
Compressive Axial Load	3979 lbf (17 700 N)	67443 lbf (300 000 N)
Tensile Axial Load	3979 lbf (17 700 N)	22481 lbf (100 000 N)
Shear Load	3754 lbf (16 700 N)	2248 lbf (10 000 N)
Torsion Moment	11063 ft*lbf (15 000 Nm)	7376 ft*lbf (15 000 Nm)
Bending Moment	50671 ft*lbf (68 700 Nm)	29502 ft*lbf (40 000 Nm)

Table 4-5: HCS Mated Load Sets

Load Set	Case 1	Case 2	Case 3	Case 4
Compressive Axial	1124 lbf (5000 N)	3979 lbf (17 700 N)	3080 lbf (13 700 N)	67443 lbf (300 000 N)
Tensile Axial	1124 lbf (5000 N)	3979 lbf (17 700 N)	3080 lbf (13 700 N)	22481 lbf (100 000 N)
Shear	1124 lbf (5 000 N)	3327 lbf (14 800 N)	3754 lbf (16 700 N)	2248 lbf (10 000 N)
Torsion	7376 ft*lbf (15 000 Nm)	7376 ft*lbf (15 000 Nm)	7376 ft*lbf (15 000 Nm)	7376 ft*lbf (15 000 Nm)
Bending	50671 ft*lbf (65 300 Nm)	28912 ft*lbf (39 200 Nm)	50671 ft*lbf (68 700 Nm)	29502 ft*lbf (40 000 Nm)

Notes for Table 4-4: and Table 4-5:

- Loads shown in these tables are for reference only. JSC-65970, iLIDS Thermal and Induced Environments is the governing document for applicable loads [R.LIDS.0027].
- Values are design limit loads.
- Hard capture hook preload and tunnel stiffness will be such that, when under external loading within limits, there remains metal-to-metal contact in the local vicinity of the hooks as specified in SSP 30559, Structural Design and Verification Requirements [R.LIDS.0124].
- Seal closure force to be included in all cases in Table 4-5.
 - Cases 1 through 3 in Table 4-5 are pressurized mated cases.
 - Case descriptions:
 - Case 1 – Attitude control by Orbiter-like, combined with crew activity.
 - Case 2 – Berthing of ISS segment while mated.

- v. Case 3 – Orbiter-like translation with payload attached to NDS.
- vi. Case 4 – TLI-like, modified from Constellation analysis. Not pressurized.

4.1.5 Leak Rate

The leak rates defined in this section assume a pressure internal to the NDS vestibule of 14.7 psia and an external vacuum pressure. The leak rate at the host interface is less than 0.0008 lbm dry air/day [R.LIDS.1114]. The leak rate at the NDS-to-NDS interface is less than 0.0025 lbm dry air/day [R.LIDS.1113]. The leak rate for feed-through connectors internal to NDS (excluding -302) is less than 0.0007 lbm dry air/day [R.LIDS.0041]. The NDS (-302) does not include feed through connectors.

When calculating the mated leak rate for a combined mated NDS stack, only account for the NDS-to-NDS leak rate once.

The following assumptions are made:

1. The leak rate at the NDS-to-NDS interface assumes 12 hooks fully engaged.
2. The leak rate for the feed-throughs internal to the NDS (excluding -302) vestibule is based on 14 class 77H hermetic feed-throughs (8X size 25 connectors, 6X size 13 connectors).

4.2 Electrical Interfaces

4.2.1 Electrical Bonding

The NDS establishes bond paths to mitigate electrical hazards on the integrated subsystem interfaces. The electrical bond meets the requirements established in NASA-STD-4003, Electrical Bonding for NASA Launch Vehicles, Spacecraft, Payloads, and Flight Equipment.

4.2.1.1 Electrical Bonding at Hard Capture (Class-R – Protection Against Radio Frequency Emission)

The NDS is protected against Radio Frequency (RF) emissions by maintaining a NASA-STD-4003 class-R bond at the “hard capture” NDS-to-NDS interface. There are three Class R bond paths between the mated systems. The first bond path is through the metal-to-metal contact on the seal interface between the two NDS mated systems. Refer to Figure 4-14. The second bond path is through the electrical umbilical connector backshell for the plug connector. The third path is through the electrical umbilical connector backshell for the receptacle connector. Refer to Figure 4-22: NDS Resource Transfer.

4.2.1.1.1 Electrical Bonding at Hard Capture (Class-H Protection Against Electrical Faults)

The NDS provides an electrical path for currents to flow in the structure between mated vehicles. There are three Class H bond paths between the mated systems. The first bond path is through the metal-to-metal contact on the seal interface

between the two NDS mated systems. Refer to Figure 4-15. The second bond path is a #8 wire carried through the electrical umbilical plug connector. The third path is also a #8 wire carried through the electrical receptacle connector. These wires are provided as a resource between the mated vehicles. Termination of these lines should be negotiated between the two vehicles. Refer to Figure 4-21 for an example of bonding between host vehicles.

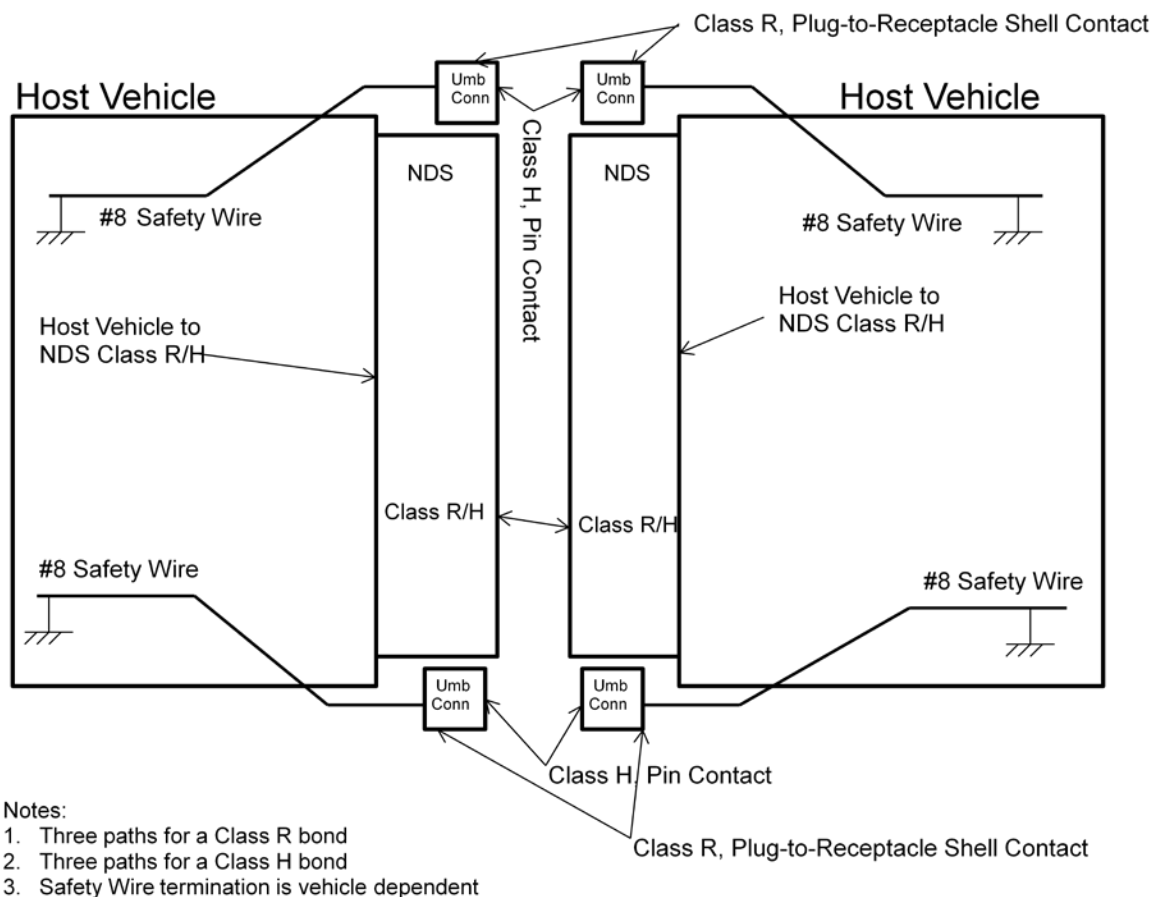

Figure 4-21: NDS Electrical Bonding

4.2.1.2 Electrical Bonding at Soft Capture (Class-S – Protection Against Electrostatic Discharge)

NDS protects against static discharge by maintaining a NASA-STD-4003, Class-S bond through the soft capture system from initial contact to hard capture during docking operations. The bond path is from the electromagnet on the NDS in the active mode to the striker plate on the NDS in the passive mode.

4.3 Resource Transfer

The NDS umbilical connector interfaces transfer resources between the docked vehicles. These resources are power, data, and ground safety wire, for the NDS configurations defined in this IDD. Future block upgrades may add water source and water return, fuel, tank pressurization and oxidizer transfer capability. All umbilical connections are recessed below the docking mating plane during docking. The umbilical connectors are mechanized such that they can be driven to mate after docking hard capture occurs. On undocking, these connectors are nominally driven to the unmated state prior to unlatching the hooks. However, they can be separated passively by the energized separation system in the event of a failure to retract the umbilicals [R.LIDS.5021]. For the NDS-to-NDS umbilical interface location, refer to Figure 4-22.

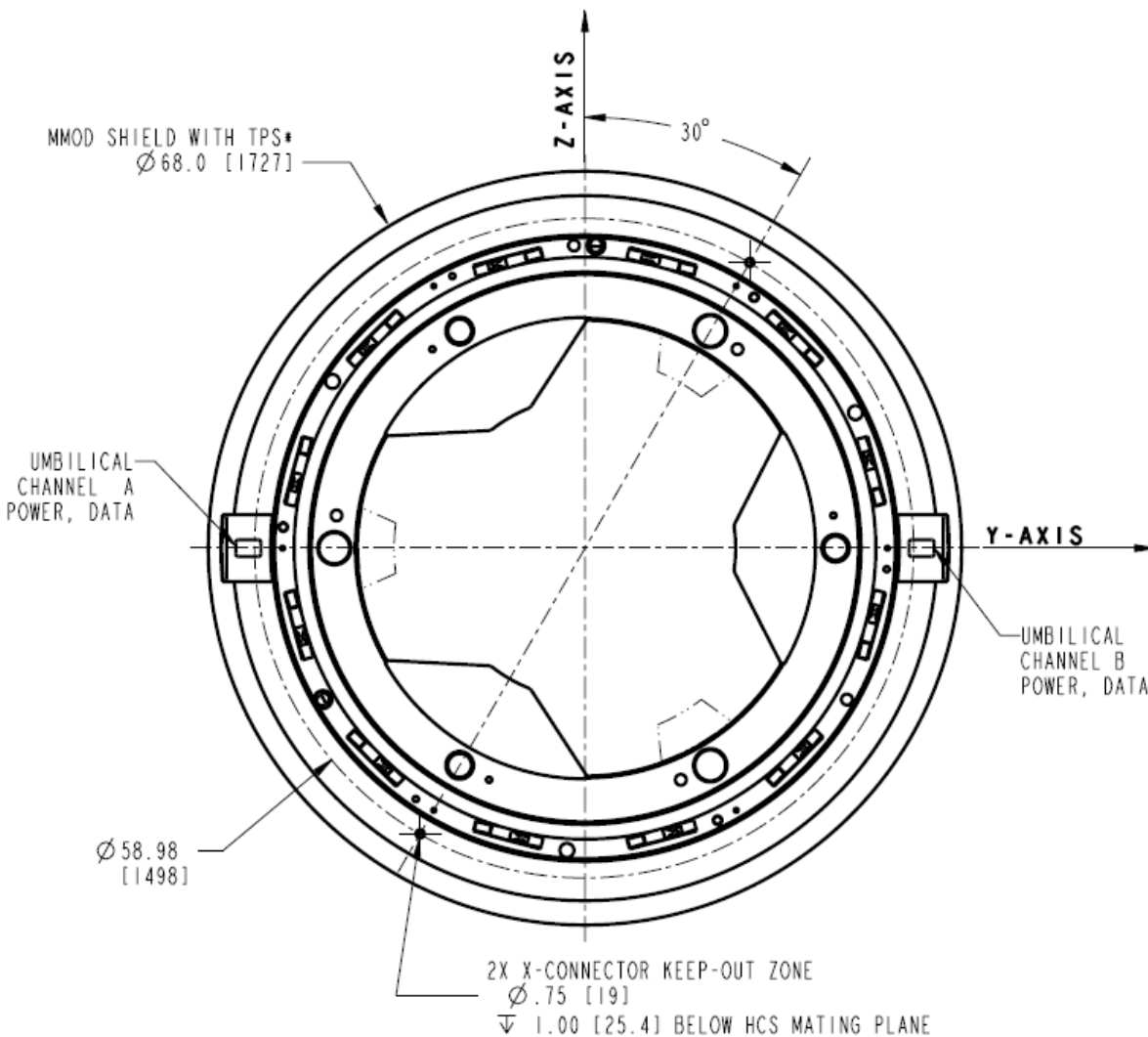

Figure 4-22: NDS Resource Transfer

4.3.1 Power Transfer and Command and Data Handling Transfer Umbilical

As shown in Figure 4-22, there are two umbilical connectors for power/data transfer. Each connector is a SSQ22680 FRAM-type connector that contains both power and data in the same connector shell. Separate power and data cable bundles are routed to the connector then combined in the connector backshell. Maximum possible separation is maintained inside the connector. The connector body is the only shared volume where these two different Electromagnetic Compatibility (EMC) classes are combined. Refer to JSC-65842, Electromagnetic Environmental Effects (E3) Requirements Document, for the exception allowing two different EMC classes to reside in the same connector.

Table 4-6: FRAM-Type Connector Pinouts [R.LIDS.5022] shows the pinouts of the FRAM-type umbilical connector.

The NDS electrical power transfer between the two docked vehicles is not used by the NDS, but only transferred between the docked vehicles. Each connector has four #8 AWG pins and wiring for power transfer [R.LIDS.0030]. The pins on either side of the interface must be assigned to match the mating vehicle for the desired power transfer. For example, this would allow transfer of two independent power circuits in a single connector. Power transfer is described in D684-14211-01, iLIDS FRAM Connector Test Evaluation.

The NDS data transfer has separate pins for MIL-STD-1553B Single Bus (A and B) and 100 Base T Ethernet interface transfer. These signals are not used by the NDS, but only transferred between the docked vehicles.

Performance (e.g., voltage drop, frequency response, etc.) for power and data transfer is described in D684-14211-01, iLIDS FRAM Connector Test Evaluation [R.LIDS.0290].

Table 4-6: FRAM-Type Connector Pinouts [R.LIDS.5022]

Umbilical Power + Data (single connector)		
P/N SSQ22680-021 (Plug)		
P/N SSQ22680-022 (Receptacle)		
P/N SSQ22680-10-004 (EMI Backshell)		
PIN #	AWG	SIGNAL
45	8	Power Circuit 1
46	8	Power Circuit 1-RTN
47	8	Power Circuit 2
48	8	Power Circuit 2_RTN
49	8	FAULT_RTN
50	8	Reserved
64	20	100BaseT_RX+
53	20	100BaseT_RX-
34	20	100BaseT_TX+
43	20	100BaseT_TX-
8	20	1553 CH 1A+
29	20	1553 CH 1A-
87	20	1553 CH 1B+

Umbilical Power + Data (single connector)		
P/N SSQ22680-021 (Plug)		
P/N SSQ22680-022 (Receptacle)		
P/N SSQ22680-10-004 (EMI Backshell)		
PIN #	AWG	SIGNAL
67	20	1553 CH 1B-
10	20	GND / Shield
89	20	GND / Shield
2	20	Loopback_1+
14	20	Loopback_1-
81	20	Loopback_2+
93	20	Loopback_2-

4.3.2 Water Transfer

The NDS will perform water source and water transfer as a future block upgrade capability.

4.3.3 Fuel Transfer

The NDS will perform fuel transfer as a future block upgrade refueling capability.

4.3.4 Pressurant Transfer

The NDS will perform tank pressurization for fuel and oxidizer transfer as a future block upgrade capability.

4.3.5 Oxidizer Transfer

The NDS will perform oxidizer transfer as a future block upgrade refueling capability.

5.0 NDS-TO-HOST VEHICLE INTERFACE

This section describes the interfaces between the NDS to a host vehicle. Specific implementation differences for various NDS configurations will be noted where applicable.

5.1 Interface Description

See Figure 5-1: NDS-to-Host Vehicle Interface Diagram.

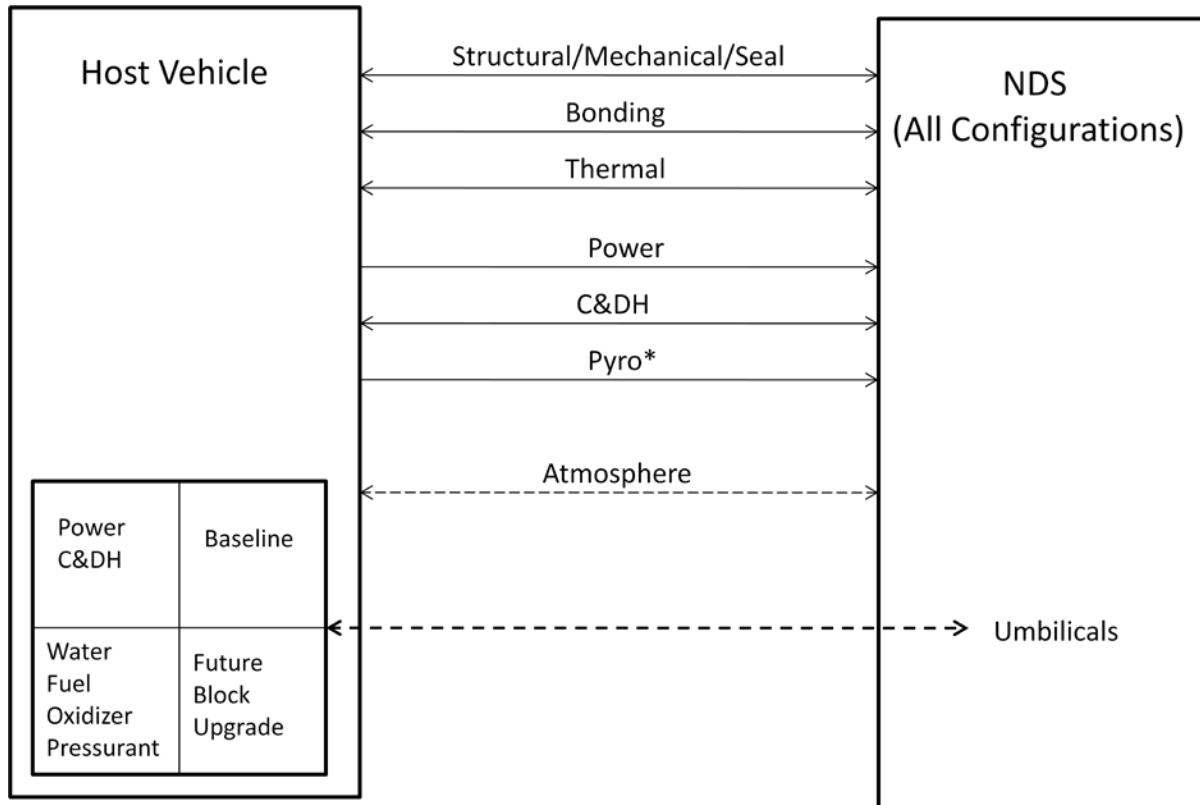

Notes: *Denotes pyro is not applicable for NDS (-302 or -304). 5-1 andling

_____ Solid lines = functional interfaces

----- Dashed lines = pass-through resources vehicle-to-vehicle

Figure 5-1: NDS-to-Host Vehicle Interface Diagram

5.2 Structural/Mechanical/Seal

The structural/mechanical/seal interface for the NDS resides at the plane of attachment between the host vehicle and the NDS. The NDS attaches directly to a bolt and seal interface flange on the host vehicle. The NDS attaches to the host vehicle with circular arrangement of fasteners.

5.2.1 Mounting Interface

5.2.1.1 NDS Mounting

The NDS will be installed with MMOD sheet metal shielding removed for host vehicle fastener access. The NDS is installed on the host vehicle by fasteners provided by NDSP. Once the NDS is mounted to the host vehicle, the NDSP provided (excluding -302) MMOD sheet metal shielding is installed on NDS using NDSP provided fasteners. In order to maintain NDS certification, the host must follow SKZ29101797, NDS Installation Procedure.

Note, for -302, MMOD shielding is provided by the host vehicle. The NDS will provide MMOD shield mounting interface defined in Figure 5-2: NDS (-302) Host Provided MMOD Interface.

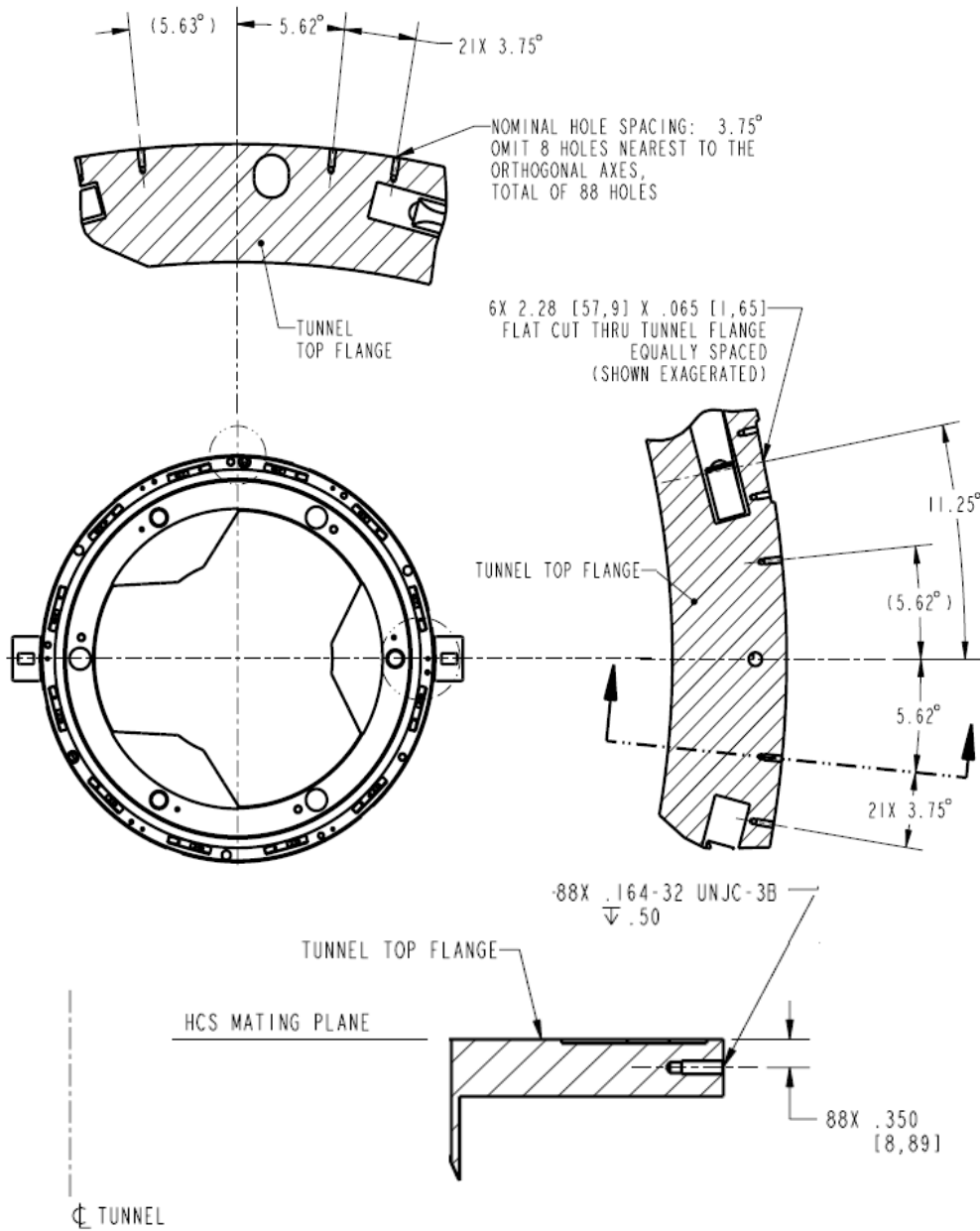

Section Thru Mounting Hole

Figure 5-2: NDS (-302) Host Provided MMOD Interface

5.2.1.2 NDS Electrical Boxes

The NDS electrical boxes with the exception of -302 are mounted within the NDS tunnel. The NDS (-302 only) electrical boxes are mounted within the host. The boxes for all configurations contain captive fasteners for host installation/replacement. Refer to Figure 5-17: NDS (-302) Remote Electrical Boxes for mounting interfaces.

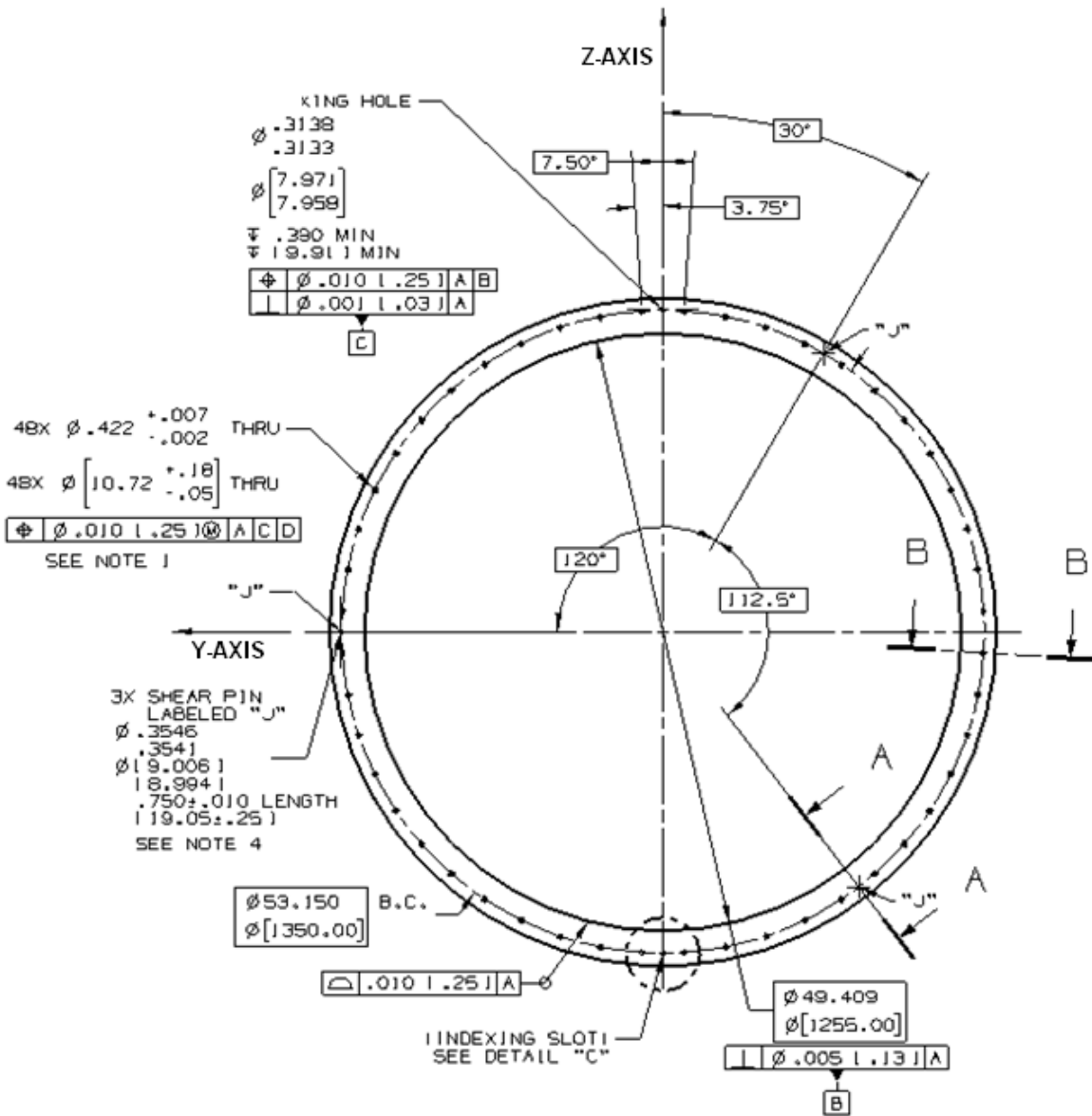

**VIEW LOOKING TOWARD NDS MATING
 FLANGE INTERFACING ELEMENT.
 (O-RINGS GROOVES OMITTED FOR CLARITY)**

Note: View looking at NDS mounting flange from the host vehicle.

(Page 1 of 5) [R.LIDS.5023]

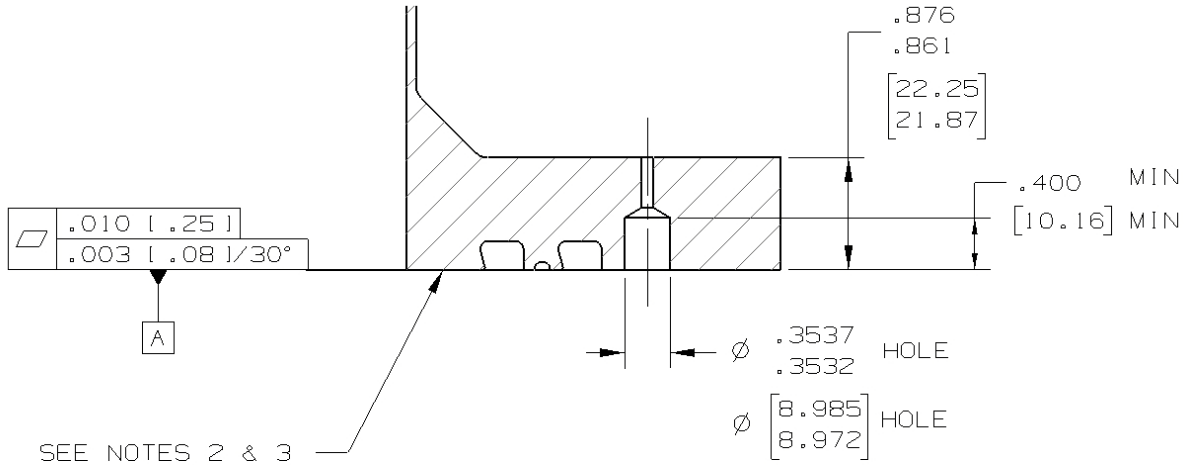

SECTION A - A
 SHOWN WITH SHEAR PIN
 ROTATED 52.50° CCW
 3 PLACES

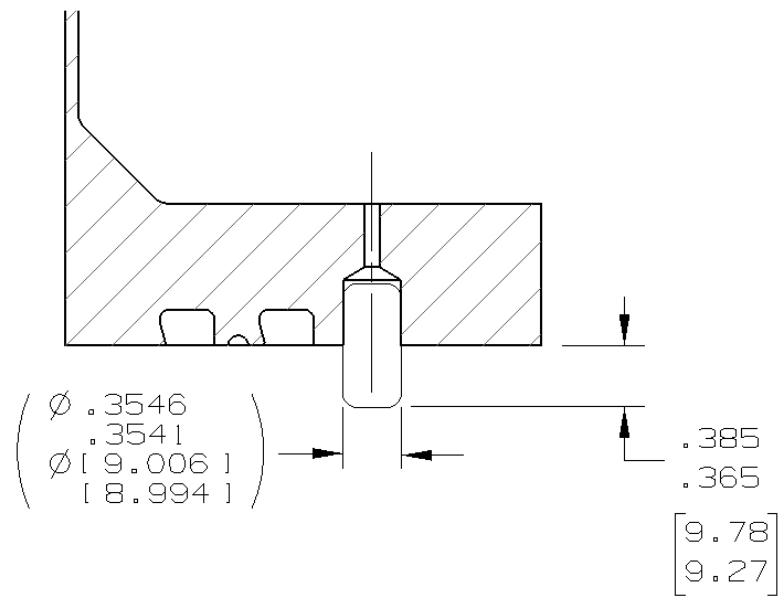

SECTION A - A
 SHOWN WITH SHEAR PIN
 ROTATED 52.50° CCW
 3 PLACES

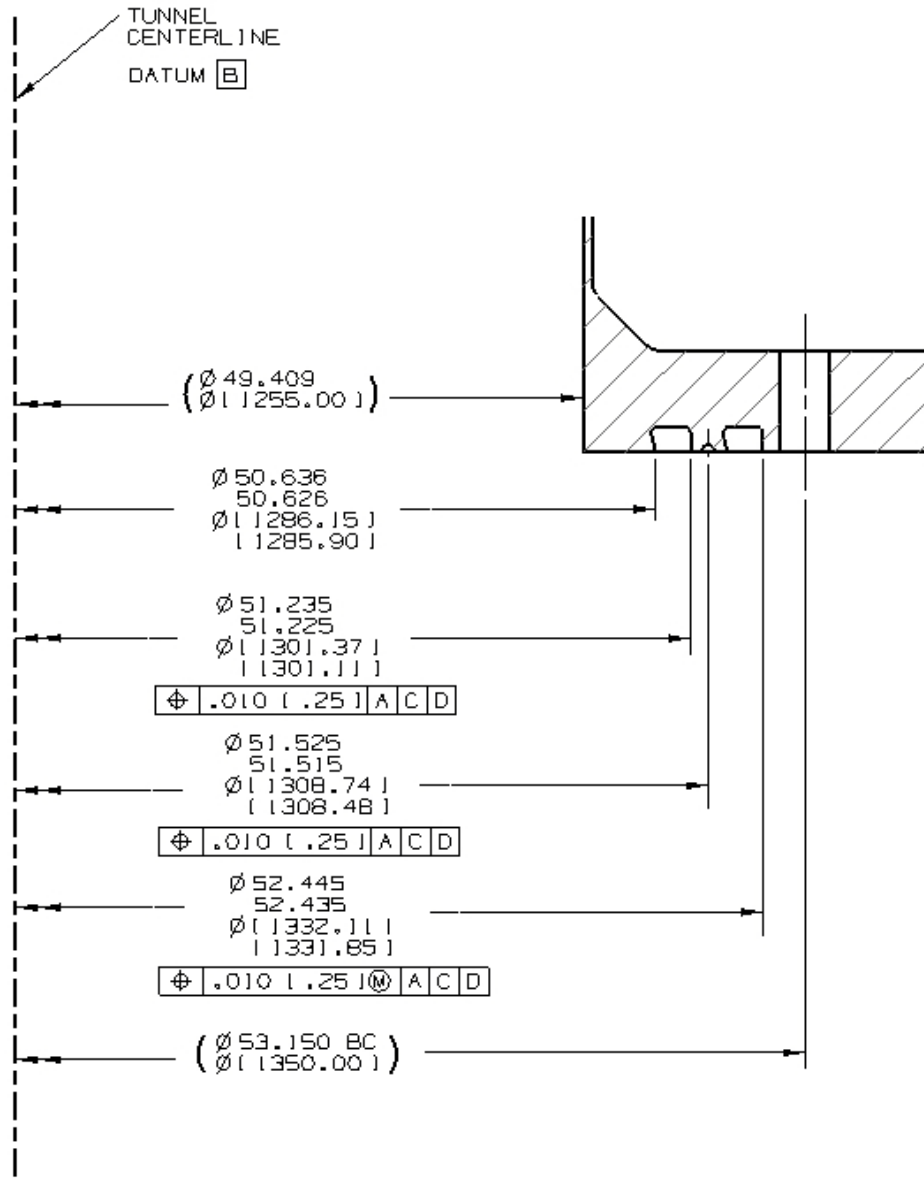

SECTION B-B
ROTATED 3.75° CCW

(Page 3 of 5) [R.LIDS.5025]

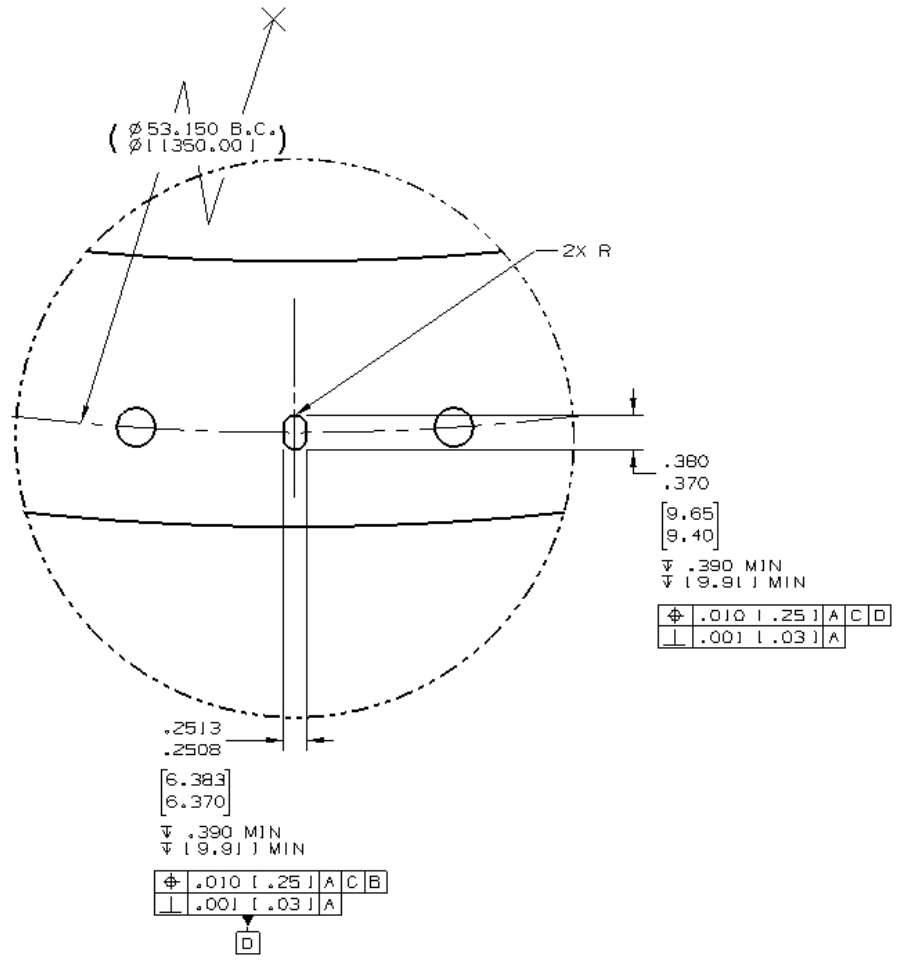

DETAIL C

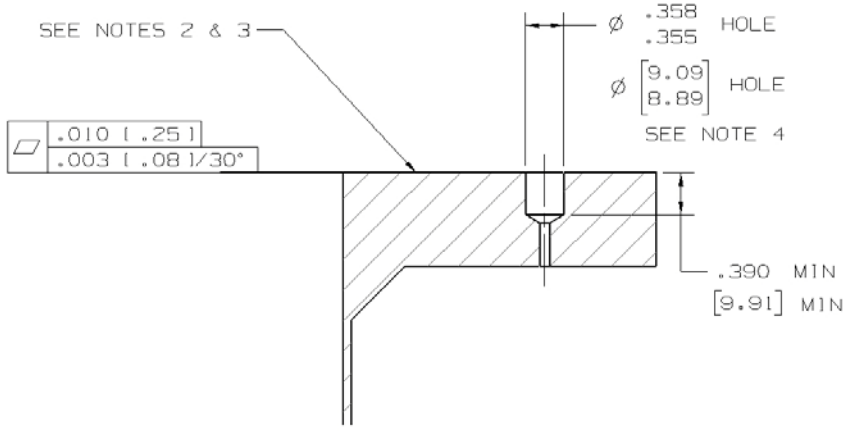

HOST VEHICLE MOUNTING FLANGE
SHEAR PIN HOLE DETAIL

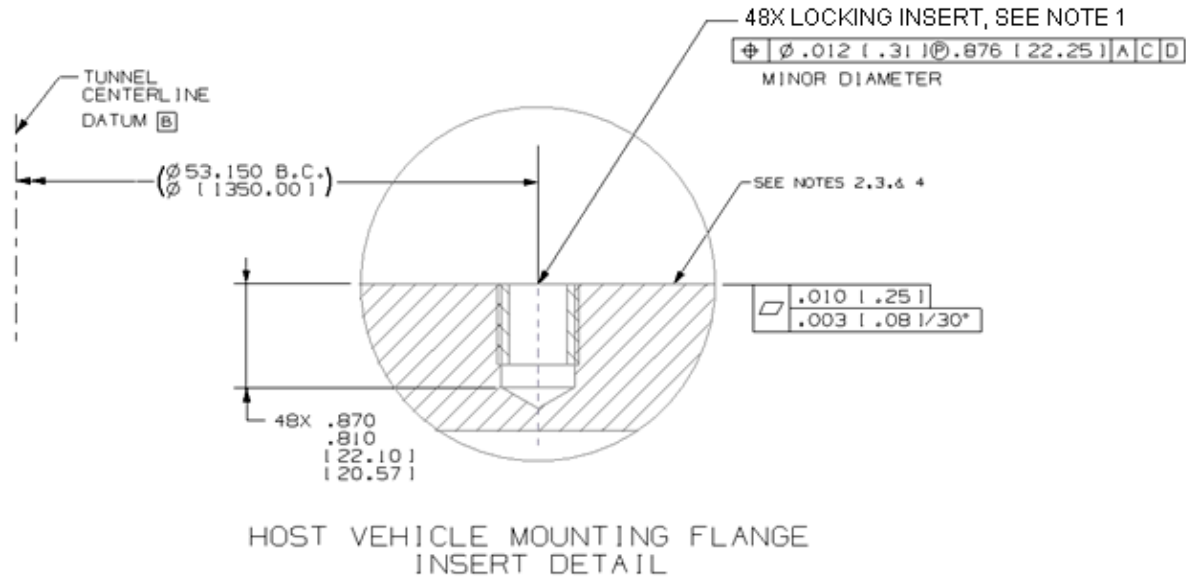

Example host threaded hole detail.

Notes:

- 1) NDS provides thru holes and associated fasteners for host vehicle mounting. Host vehicle provides mating insert part number: KNML10 x 1.5T Keensert, vendor: Fairchild Fasteners.
- 2) Chemical conversion coat per MIL-DTL-5541, Type 1, Class 3.
- 3) Host vehicle to provide mating surface coating per Note 2. Host surface flatness must match NDS surface flatness per Figure 4-14: and Figure 4-15:. The host surface finish requirements apply to the surfaces within a minimum of .25 [6] width margin on each side of the seal pair. Refer to Section B-B (this figure page 3 of 5) for seal bead locations.
- 4) Located with drill template tool (684-016105 – Drill Template, NDS – Host Interface) provided by NASA using datums A, C, and D to achieve Class 1 fit of shear pins to mating holes.

(Page 5 of 5)

Figure 5-3: NDS-to-Host Vehicle Mounting Interface [R.LIDS.0001]

5.2.2 Mechanical Mounting and Seal Interface

The host vehicle provides a seal land which corresponds to seal locations defined in Details and Figure 4-15: NDS (-302) HCS Mating Plane Seal and Electrical Bonding Details. The NDS will provide the seals for this interface that are capable of limiting leakage as specified in Section 4.1.5, Leak Rate.

5.2.3 Thermal Interface

The thermal environments and analysis approach is documented in JSC-65970, iLIDS Thermal and Induced Environments.

5.2.3.1 NDS-to-Host Vehicle

The thermal contact conductance across the NDS-to-host vehicle interface is defined as ranging from 15 Btu/hr-ft²-°F to 50 Btu/hr-ft²-°F for the metal-to-metal contact area [R.LIDS.5027].

For -302 electrical boxes, the thermal contact conductance from the electrical boxes to the host provided mounting interface is 1.04 Btu/hr-°F at each of the two mounting interfaces per box for the metal-to-metal contact area. The host mounting interface cannot exceed 122°F.

The NDS utilizes heaters to condition/maintain temperatures above the minimum limits for each operating mode.

Warning: Unmated NDS systems in Solar Inertial attitudes with the NDS facing the Sun are known to cause violations of operational and survival limits. In these attitude/configuration conditions time constraints will be imposed to protect the NDS. Refer to JSC-65978, iLIDS Thermal Data Book.

The allowable NDS-to-host vehicle interface acceptance temperature ranges for each operating condition are defined as follows.

5.2.3.1.1 Non-Operational Survival

The following applies when the docking system is unmated under non-operational conditions. Only heaters are active at this point.

-58 °F to +192 °F (-50 °C to +89 °C) [R.LIDS.1051]

Minimum – The defined minimum interface temperature of -58 °F (-50 °C) is the limit at which the NDS heaters can maintain the temperatures of the NDS components above their minimum survival limits.

Maximum – The defined maximum interface temperature of +192 °F (+89 °C) is the lowest maximum acceptance level temperature limit for the NDS hardware.

5.2.3.1.2 Operational

The following applies when the docking system is preparing to dock up through hard mate but prior to pressurization.

-22 °F to +122 °F (-30 °C to +50 °C) [R.LIDS.5038]

Minimum – The defined minimum interface temperature of -22 °F (-30 °C) is the limit at which the NDS heaters can maintain the temperatures of the NDS components above their minimum operational limits.

Maximum – The maximum temperature of +122°F (+50°C) is the maximum allowable tunnel temperature, which allows electronics to perform the docking power profile without violating their maximum temperature limits.

5.2.3.1.3 Mated and Pressurized

The following is the steady state temperature after hard mate and pressurization. The time allowable to achieve this steady state temperature is 8 hours [R.LIDS.5028]. Analysis has shown that after hard mating, it can take as long as 8 hours in a cold environment for an NDS to warm up to the minimum dew point temperatures when starting from the minimum allowable operating temperatures. This warm up profile is shown in Figure 5-4: NDS Post Hard Mate Warm Up Profile. This does not restrict pressurization or hatch opening but would result in condensation within the vestibule during this transition period.

The length of time could be reduced by changing the NDS heaters to the mated/pressurized setpoints prior to hard mate. This will heat the NDS above minimum operating temperatures. In this operation, the temperatures achieved prior to mating are dependent on environment, heater power and the time duration between setpoint change and hard mating.

Min °F to +113 °F (min °C to +45 °C) [R.LIDS.1051]

Minimum – The minimum temperature may be specified by the host vehicle and the docking system setpoint will be adjusted accordingly. The docking system assumes the host vehicle minimum temperature is set above the dew point.

Maximum – The maximum temperature of +113°F (+45°C) is defined by the bare handed touch temperature limit.

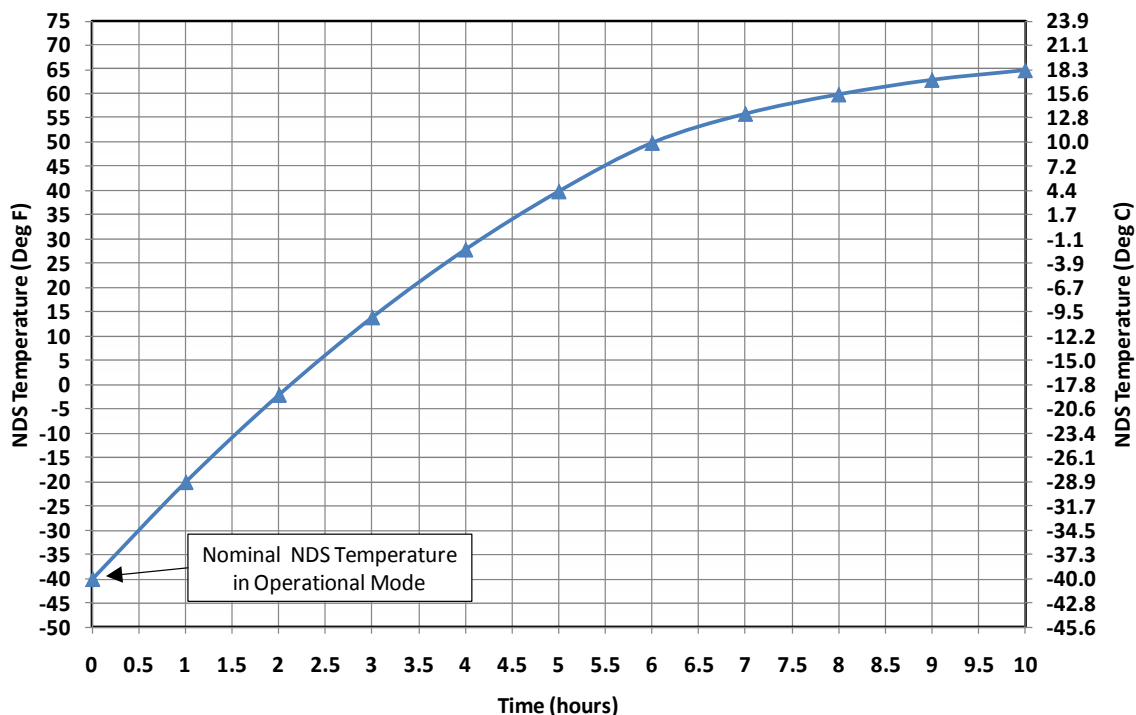

Figure 5-4: NDS Post Hard Mate Warm Up Profile

5.2.3.2 NDS (-302 only)

The thermal contact conductance across the NDS (-302) to CDA tunnel interface is defined as ranging from 15 Btu/hr-ft²-°F to 50 Btu/hr-ft²-°F for the metal to metal contact area [R.LIDS.5029].

The Multi-Layer Insulation (MLI) thermal cover and MMOD external shielding for -302 is provided by the host.

5.3 NDS-to-Host Vehicle Electrical and Signal Interface

This section describes the electrical and signal interfaces between the NDS and the host vehicle. As indicated in Figure 5-5: NDS-to-Host Vehicle Electrical Interface, there are two NDS-to-NDS electrical umbilical connectors allowing redundant electrical signals. Both power and C&DH is routed through a single connector. However, after exiting the backshell of the NDS-to-NDS umbilical connector, the power and C&DH are separated and run to individual connectors at the host side. The NDS electrical connections are located as shown in Figure 5-13: NDS (excluding -302) to Host Vehicle Electrical Interface. The electrical interface between the NDS and the host vehicle has the functions indicated in Figure 5-5.

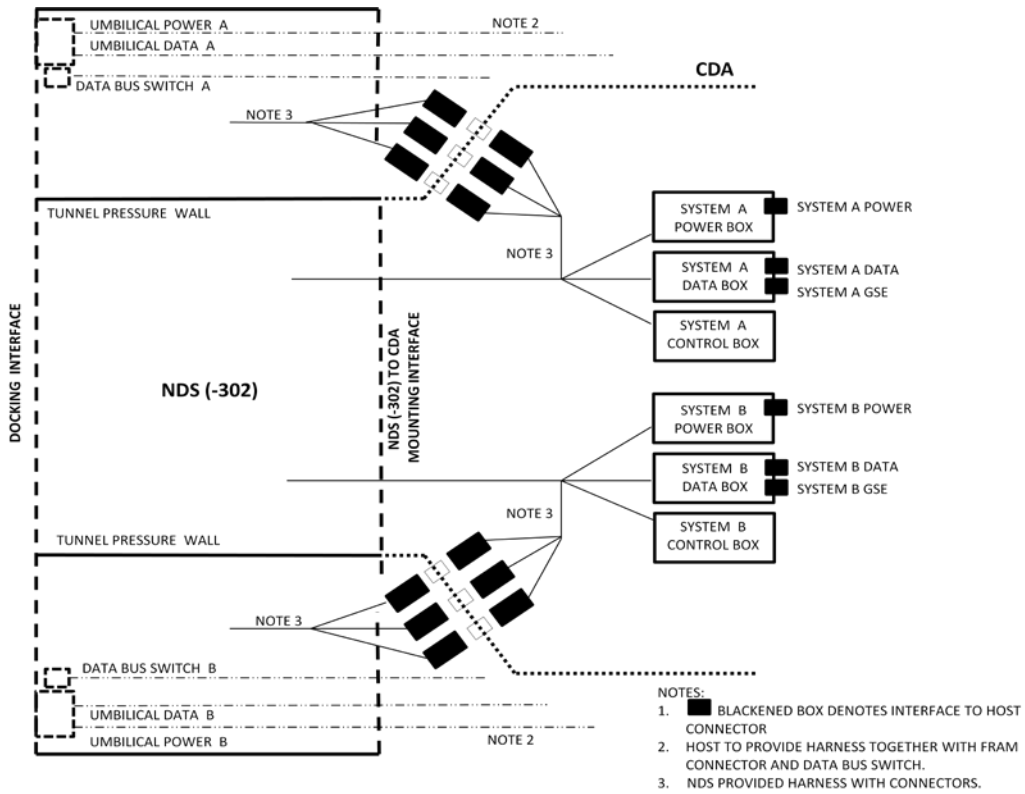
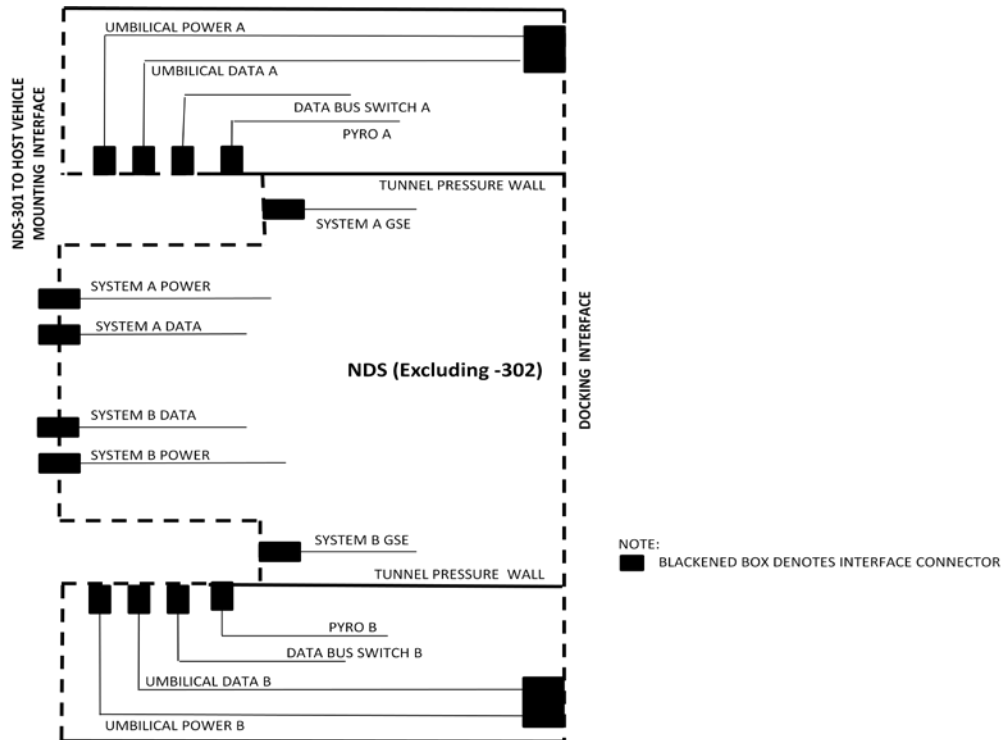

Note: NDS (-302) interface is schematic representation only; not physical location.

Figure 5-5: NDS-to-Host Vehicle Electrical Interface [R.LIDS.5030]

5.3.1 Umbilical Power Transfer Interface-to-Host Vehicle

The vehicle interface has a separate connector for power and data, unlike the NDS umbilical interface, which combines power and data. Refer to NDS power transfer capability defined in Section 4.3.1. The pinouts are shown in APPENDIX F [R.LIDS.5031].

5.3.2 Umbilical Data Transfer Interface-to-the Host Vehicle

Refer to NDS data transfer capability defined in Section 4.3.1. Unlike the NDS umbilical interface, which combines power and data, the vehicle interface has a separate connector for data. Refer to Figure 5-13: NDS (excluding -302) to Host Vehicle Electrical Interface. The pinouts are shown in APPENDIX F.

5.3.2.1 Umbilical Connector Mated Indication

The data connector interface to the host provides indication that pins have engaged between the NDS-to-NDS umbilical connectors. Each connector has pins that are electrically shorted together; when the connectors mate, this short can be sensed by the docking vehicles. This is an indication that the connectors are seated and the pins have engaged. This indicates that power and data can be exchanged. Interface shows the umbilical locations to the host vehicle.

5.3.2.2 Umbilical Connector Data Bus Termination Switch

A connector containing the MIL-STD-1553B termination wires is located at the interface. The termination switch operates when the mating umbilicals are in contact. The pinouts are shown in APPENDIX F.

5.3.3 Pyrotechnic Interface NDS (-301 and -303)

The NDS (-301 and -303 only) contains pyrotechnics in both the active and passive hooks at the hard mate interface [R.LIDS.1115]. Therefore, if the NDS active hooks fail to unlatch, the host may fire the pyrotechnics releasing hooks. The 24 hooks will be fired in gangs six at a time in an alternating pattern, with a maximum of 100 ms (TBR-40) between firings [R.LIDS.1115]. The total time required for hook release within one gang of six hooks is less than 150 ms (TBR-40) [R.LIDS.1115]. The control and inhibits for this firing are provided by the host vehicle. The host provides three inhibits to inadvertent firing. There are 24 NASA Standard Initiators (NSI) in NDS (one per hook). For each NSI, the host must provide a pyrotechnic controller channel [e.g. Pyrotechnic Event Controller (PEC) or Pyrotechnic Initiator Controller (PIC)]. Pyrotechnics would be used as contingency in the event of two failures to undock. Therefore, no redundancy is required in the NSIs or pyrotechnic controller channel. All pyrotechnics used in this system follow the requirements of JSC 62809, Human Rated Spacecraft Pyrotechnic Specification [R.LIDS.1103]. In the event of activation of the pyros, all potential Foreign Object Debris (FOD) are contained [R.LIDS.5032]. The docking system vestibule must be depressurized prior to pyrotechnic separation of the host vehicles.

The NDS induces pyroshock on the host vehicle per Figure 5-6: Maximum Pyroshock Levels at NDS/Host I/F for Contingency Pyrotechnic NDS Separation. Refer to Figure 5-13: NDS (excluding -302) to Host Vehicle Electrical Interface. The NDS provides connectors for host initiation of the pyrotechnics. The pinouts are shown in APPENDIX F.

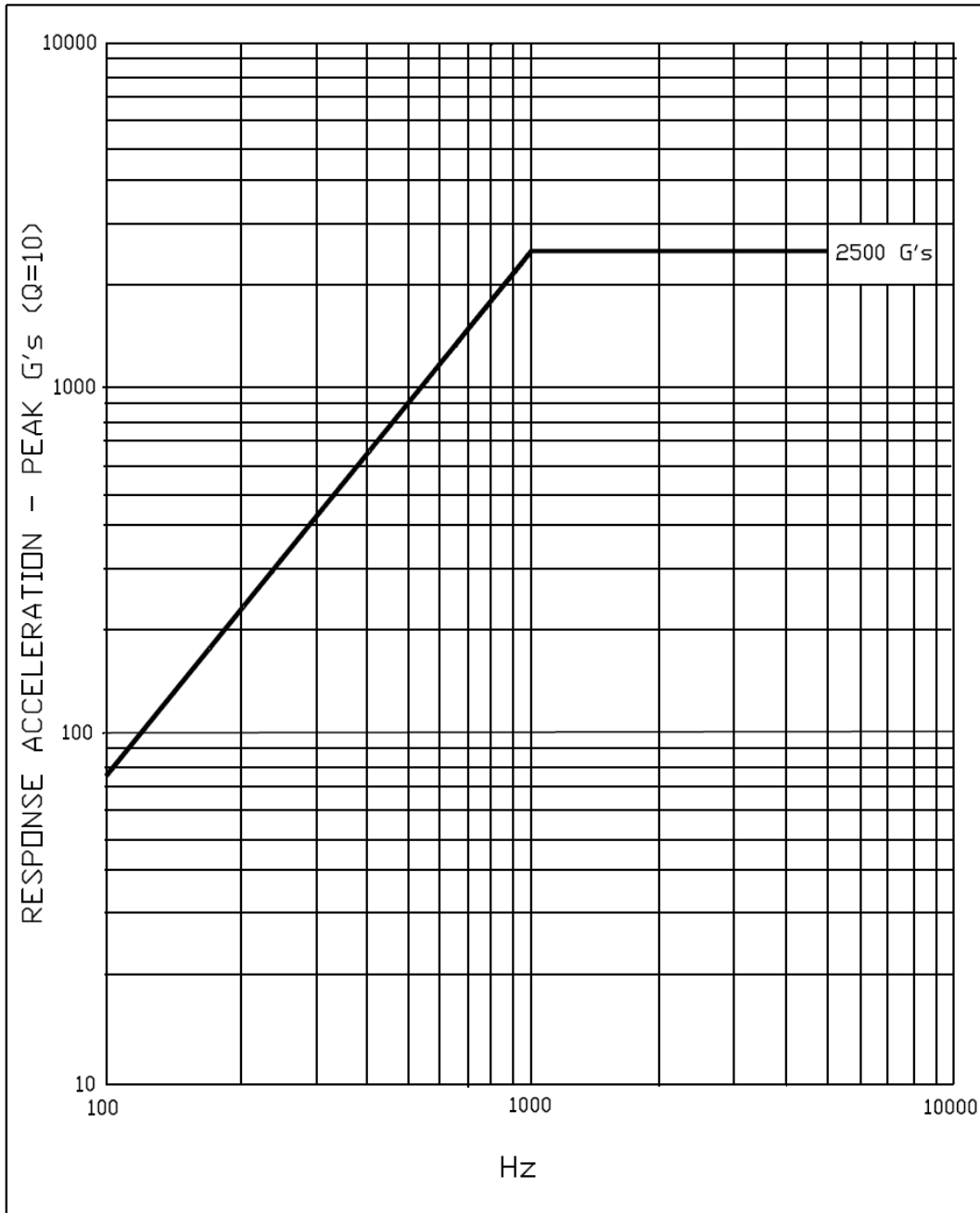

Figure 5-6: Maximum Pyroshock Levels at NDS/Host I/F for Contingency Pyrotechnic NDS Separation

5.3.3.1 Pyrotechnic Interface NDS (-302 and -304)

The NDS (-302 and -304) does not contain pyrotechnics for hook release; therefore, there is not pyrotechnic electrical interface on the NDS (-302 and -304). The pyro bolt in the active and passive hooks is replaced with an inert bolt. Using pyrotechnics on the NDS (-302) for CDA would foul the port such that it could no longer be used for docking. The ISS will rely on the visiting vehicle undocking redundancy and pyrotechnics to allow the visiting vehicle to depart. The NDS (-304) does not contain pyrotechnics in order to reduce mass.

5.3.4 Electrical Power from Host Vehicle-to- NDS

The NDS operates with power from the host vehicle that meets the JSC-64599, iLIDS Power Quality Description Document [R.LIDS.0003]. All NDS configurations (excluding -303) operate on 120 Vdc. The NDS (-303) operates on 28 Vdc power from the host vehicle. There are two redundant power system feeds required: one for system A and one for system B. Both system A and system B will draw power during the docking/undocking event Per JSC-64599.

5.3.5 Communications Between the Host Vehicle and the NDS

The NDS receives command and data handling (C&HD) commands (e.g., docking, undocking, docking termination) from the host vehicle through a serial interface. There are two serial formats available: TIA-422-B and MIL-STD-1553B. The host indicates desired serial communications by installing a jumper in the host communications connector. See APPENDIX F for the pinout and installation of the jumpers. All communication, commands, and data and status for operating the NDS are sent through this serial port. This serial port controls both the NDS docking system and the heater controller. The TIA-422-B serial data channel is described in Figure 5-7: Block Diagram TIA-422-B Serial Communications Host Vehicle to NDS. The MIL-STD-1553B serial communications port is described in Figure 5-8: Block Diagram MIL-STD-1553B Serial Communications Host Vehicle to NDS.

5.3.5.1 Command and Data Handling Interface, Physical Layer SOA

The TIA-422-B C&HD interface is protected against lightning transients up to the limits shown in Figure 5-9: Safe Operation Area for TIA-422-B C&DH Serial Port. These curves were computed for the Transient Voltage Suppressor (TVS) using the ARP5412 lightning current impulse waveforms. Open circuit voltage and short circuit current refer to the circuit parameters at the NDS host connector.

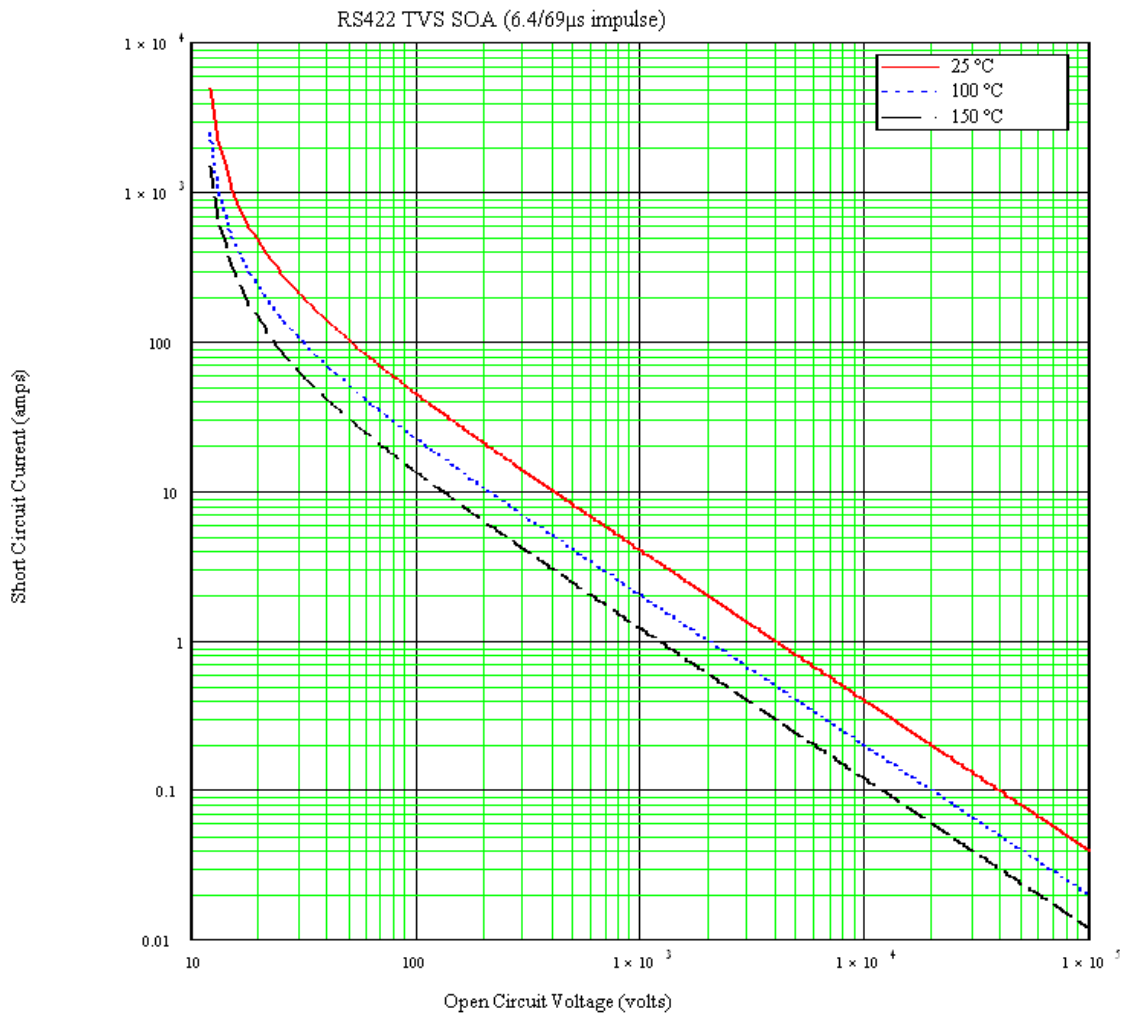

Figure 5-9: Safe Operation Area for TIA-422-B C&DH Serial Port [R.LIDS.5033]

5.3.6 Heater Power and Control

The NDS has internal active heater elements, which allow it to survive and operate to the thermal levels in Section 5.2.3.1. Heater power is redundant with one heater circuit for NDS system A and another independent power input for system B. Each channel has a power requirement of 0 to 400 W at 120 Vdc, although only one

channel is active at a time the other is in standby [R.LIDS.5034]. Refer to JSC-64599, Electric Power Quality Description Document for heater power timelines. Control for the heater is through the same serial port that is used to control the NDS Docking system described in Section 5.3.5 above. For TIA-422-B heater, refer to APPENDIX C. For MIL-STD-1553B heater commands, refer to Table 5-1.

Table 5-1: Heater Command List for MIL-STD-1553B Serial Port

Command	Code(Hex)	Action
Heater Controller System A Remote Terminal (RT) Address	TBD-48	ISS 1553 RT address for System A
Heater Controller System B RT Address	TBD-48	ISS 1553 RT address for System A
Status	TBD-48	TBD-48 Byte packet of: <ul style="list-style-type: none"> • RTD temp readings for heaters; two TBD-48 values per heater channel • RTD temp readings for heater electrical circuits • Health information
Load Heater Setpoints	TBD-48	TBD-48 Byte packet of: <ul style="list-style-type: none"> • Override default heater setpoints; one TBD-48 value per heater channel • Adjust thermal management profile • Override thermal shutdown
Reset	TBD-48	Force internal state machine to recycle

5.3.7 GSE Software Interface to NDS

The NDS provides two GSE connectors, one for system A and one for system B. The connectors allow for maintenance and upgrades. These connectors are not used by the host vehicle and will only be uncapped during maintenance. The GSE circuits allow direct access to the processor and the Complex Electronics (CE).

5.3.8 Electrical Bonding Between the Host Vehicle and the NDS

NDS establishes bond paths to mitigate electrical hazards on the ground test article and integrated subsystem interfaces. The electrical bond meets the requirements established in NASA-STD-4003, Electrical Bonding for NASA Launch Vehicles, Spacecraft, Payloads, and Flight Equipment. The NDS will be protected against radio frequency emissions by maintaining a class-R/H bond at the NDS-to-host vehicle interface. The DC bond resistance across the interface will be 2.5 milliohms or less.

The bond path will be through the chemical conversion coated metal to metal contact on the seal interface between the host vehicle and the NDS, and through the #8 wires provided in the umbilical for grounding/bonding. Refer to Figure 5-13.





5.4 NDS-to-Host Vehicle Software Interface

The NDS will receive commands from the host vehicle for docking, undocking, docking termination, undocking termination, pause docking, pause undocking, checkout, idle and reconfigure. Refer to JSC 64096, Software Requirements Specification for the ILIDS Control System Software for details on software functionality modes and states. The NDS will also validate commands from the Host Vehicle and send command responses to the host vehicle. Periodic H&S data will be sent to the host vehicle at 50 Hz. NDS-to-Host Vehicle Application Software Interface

This section will describe the NDS-to-host vehicle application software interface. The host vehicle application software provides the vehicle interface for NDS. It supports NDS-vehicle command and data processing and some NDS Fault Detection, Isolation, and Recovery (FDIR).

The following sections contain UML communication diagrams to illustrate the communication sequence. See Table 5-2: UML Communication Diagram Elements for details.

Table 5-2: UML Communication Diagram Elements

Communication Diagram Element	Description
 Actor	An Actor is a user of the system
 Object	An Object is a particular instance of a Class at run time.
 Entity	An entity component typically passes information in and out of interfaces and is often persisted as a whole.
 Message	Messages indicate a flow of information or transition of control between elements.

5.4.1.1 NDS to Host Command Handling

Refer to Figure 5-10: Host Vehicle-to-NDS Command Handling Interface for a graphic depiction of the command handling process between the host vehicle and the NDS. Specific steps are described below.

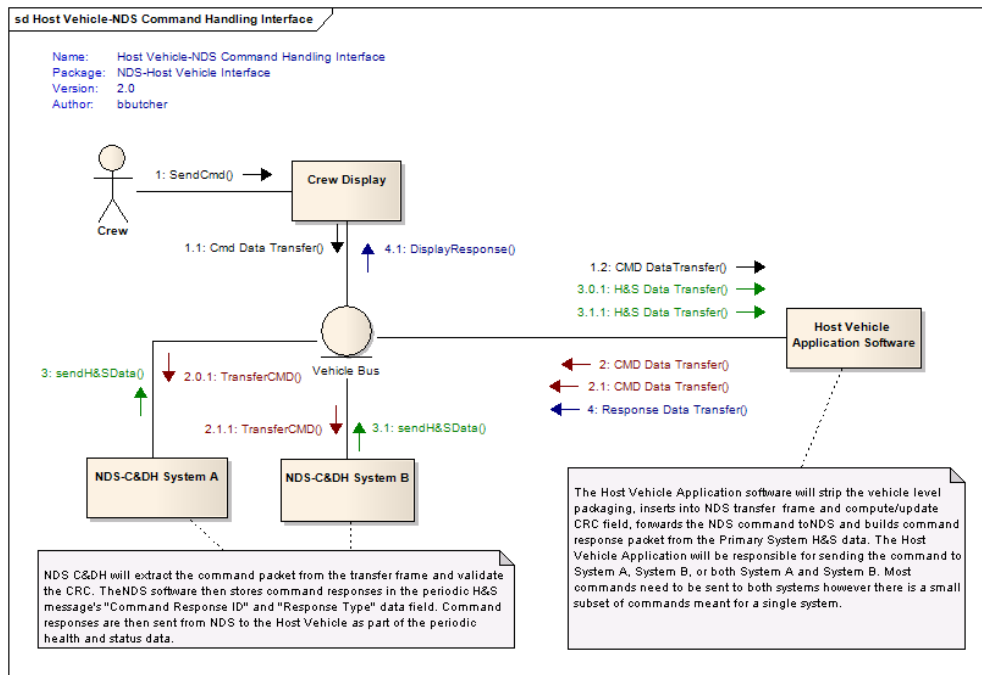

Figure 5-10: Host Vehicle-to-NDS Command Handling Interface

1. A command is sent to the NDS from the host vehicle.
2. The command packet is routed to the host vehicle application software, which then:
 - a. Inserts into the transfer frame and computes/updates the Cyclic Redundancy Check (CRC) field.
 - i. Adds transfer sync bits and CRC.
 - b. Determines which NDS system to send the command based on the Command ID (CID). It is possible for a command to go to a single system or both systems depending on the command. Each individual system/string does not know which one it is, only the vehicle knows which data path is tied to which system. (This requires the vehicle to have separate commands for tasks such as Enable system A and Enable system B.)
 - c. Forwards the NDS command to the correct LIDS system.
3. The NDS receives the command and processes the command, which includes validation and execution.

- a. Extract command packet from the transfer frame and validates the CRC.
 - b. The NDS software then stores command responses in the periodic H&S message's "Command Response ID" and "Response Type" data field.
 - c. Command responses are then sent from NDS to the host vehicle as part of the periodic H&S data at 50 Hz. If no response is present, the status bits will be set to indicate that no command was processed this cycle.
4. Host vehicle application software receives the H&S packet from the primary system and processes the command response based on the command response status field.
 5. The response packet is then sent back to the command source.

5.4.1.2 NDS-to-Host Vehicle H&S Data Handling

Refer to Figure 5-11: Host Vehicle-to-NDS H&S Data Handling Interface for a graphic depiction of the H&S data handling process between the host vehicle and the NDS. Specific steps are described below.

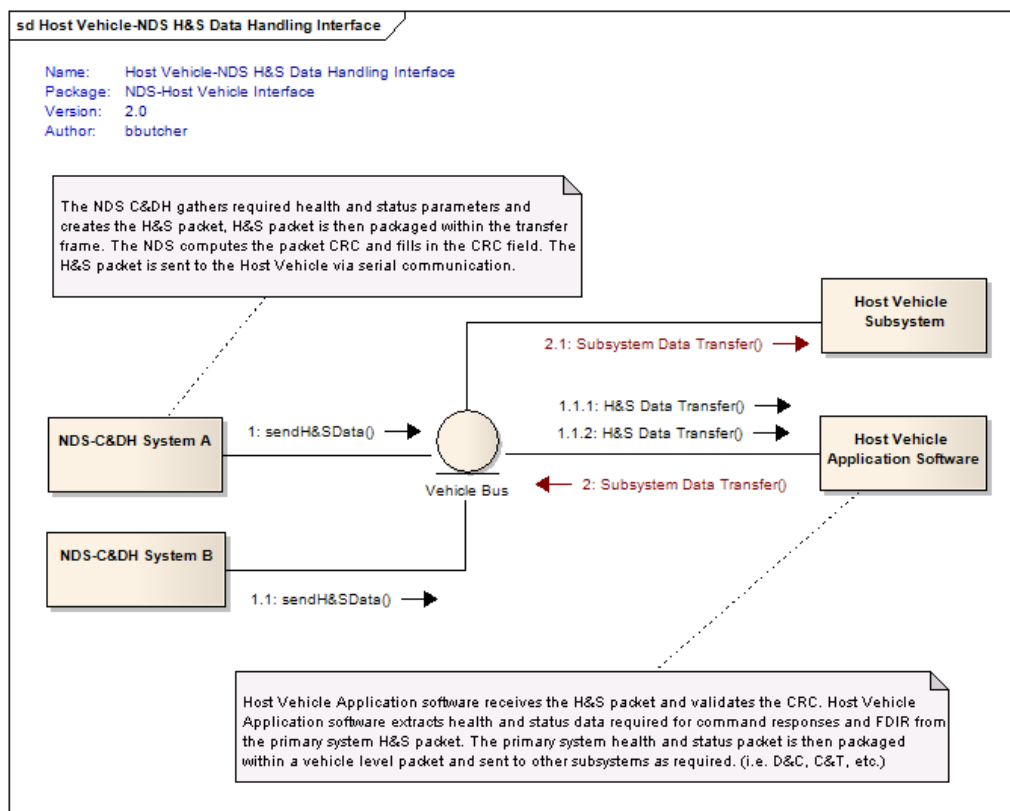

Figure 5-11: Host Vehicle-to-NDS H&S Data Handling Interface

1. NDS sends H&S data to the host vehicle at 50 Hz.

- a. NDS system A and system B gathers required H&S parameters and creates the H&S packet.
 - b. H&S packet is packaged within the transfer frame.
 - c. NDS computes the packet CRC and fills in the CRC field.
 - d. The H&S packet is sent to the host vehicle via serial communication from system A and system B.
2. The packet is received by the host vehicle and the packet is forwarded to the host vehicle application software.
 3. The host vehicle application software receives the H&S packet for system A or/and system B.
 - a. Receives H&S packet and validates the CRC.
 - b. The host vehicle application software extracts H&S data required for command responses and FDIR from the packet.
 - c. The primary system H&S packet is then packaged within a vehicle level packet and forwarded to required subsystems [i.e., Display and Control (D&C), Communication and Tracking (C&T), etc.] (Note: An assumption has been made that only primary NDS status will be sent to other applications.)

5.4.1.3 NDS FDIR

NDS has two controllers: system A and system B. If the NDS detects a fault in system A then the host vehicle needs to switch control to system B because NDS cannot make this switch on its own. Systems A and B do not communicate directly with each other in any way. The fault switching function has to be performed in the host vehicle. If a fault requiring a switch to the redundant string is identified, there is a minimum amount of time to switch between controllers in order to maintain safe control of the linear actuators, depending on the mode and state of NDS. This switch time is most critical during dock mode capture and attenuation states. Two hundred ms is the max total time required for a switch from A to B to take place. This time is from fault detection, outputting the fault indicator in NDS H&S data to the host vehicle, the passage of the H&S message through host vehicle subsystem interfaces, busses/networks, into the flight computer/software that is monitoring the fault indicator, and the time it takes for the host vehicle's switch command to traverse back to NDS to effect the switch. The total time has to be allocated between NDS and the host vehicle. The host vehicle will be required to switch primary control from the NDS system A to system B within 120 ms when it receives the indication from NDS that a fault has been detected in the primary controller and needs to be switched to the backup controller, where the performance measurement is taken from the time the NDS indication crosses the host vehicle-to-NDS interface to the time the host vehicle's response command crosses the host vehicle-to-NDS interface. Refer to Figure 5-12: Host Vehicle-to-NDS FDIR Handling Interface.

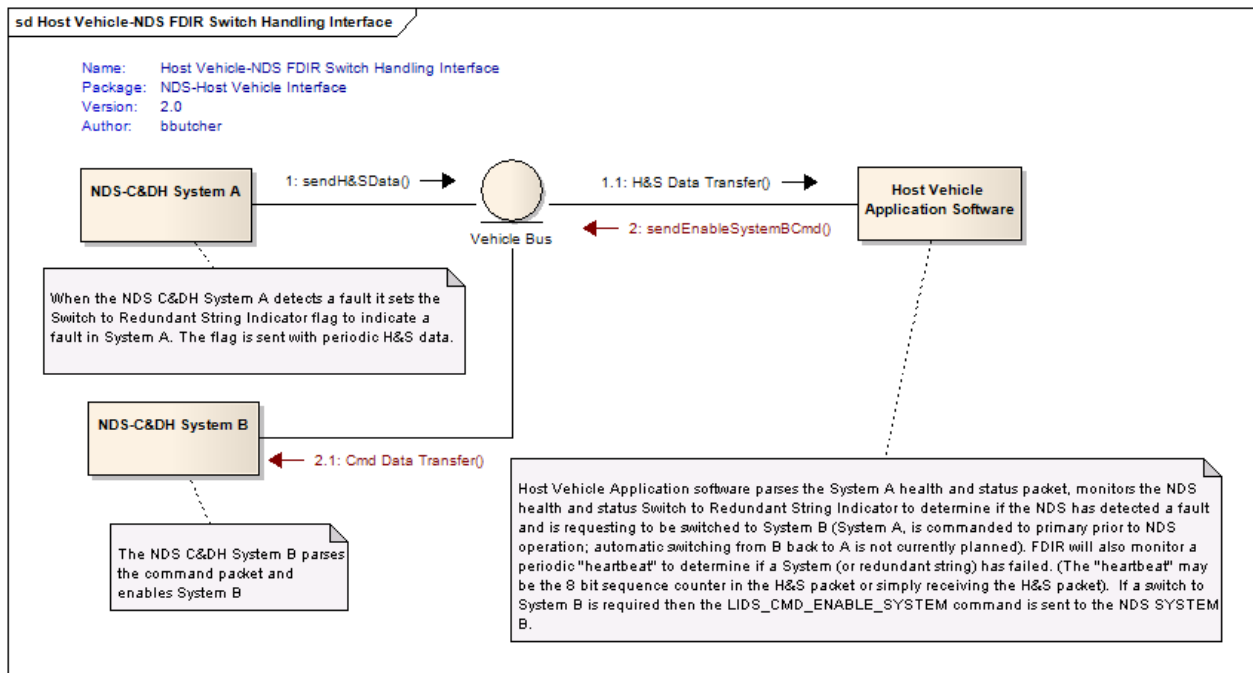

Figure 5-12: Host Vehicle-to-NDS FDIR Handling Interface

1. The host vehicle application software parses the H&S packet of the primary system for required FDIR parameters.
 - a. The host vehicle application software will monitor the NDS H&S switch to redundant string indicator to determine if NDS has detected a fault and is requesting to be switched to system B (system A or string A is commanded to primary prior to NDS operation; automatic switching from B back to A is not currently planned).
 - b. FDIR will also monitor "heartbeat" at 50 Hz to determine if a system (or redundant string) has failed. (The "heartbeat" may be the combination of a sequence counter in the H&S packet as well as receiving the H&S packet)
2. Each processing cycle, the host vehicle application software checks that the periodic heartbeat was received. If the heartbeat is missing for three cycles from currently enabled system (redundant string), then:
 - a. The host vehicle application software powers down NDS system A.
 - b. The LIDS_CMD_ENABLE SYTEM command is sent to NDS system B.
3. If the heartbeat exists then the host vehicle application software checks the switch to redundant string indicator to see if a system (redundant string) switch is required. If a switch to system B is required then:
 - a. The host vehicle application software powers down NDS system A.

- b. The LIDS_CMD_ENABLE_SYSTEM command is sent to NDS system B.
- c. Note: The enable system command makes that system “primary.” “Primary” only has meaning with respect to linear actuator control. The only thing that makes a system primary is enabling the linear actuator effector control output. Only one string can control the linear actuators at one time. However, both strings always control all other mechanisms.

5.4.2 NDS Packet Structures

The NDS communications will consist of two application level packet structures that include a command packet and an H&S packet. The command packet will be used by the host vehicle to command the NDS operations. The command packet has a size of 58 Bytes. NDS data packets are 32-bit word aligned and use big endian byte ordering. See Table 5-3: Host Vehicle-to-NDS Command Packet for details. See Table 5-4: Host Vehicle-to-NDS Command Packet Parameters for parameter definitions.

Table 5-3: Host Vehicle-to-NDS Command Packet

Primary Header						Packet Data Field				
						Secondary Header		Payload		
Packet Version (3 bits)	Packet Identification			Packet Seq. Control		Packet Data Length (16 bits)	Time-stamp (64 bits)	Cmd ID (16 bits)	Rsvd (16 bits)	Payload (40 Bytes)
	Packet Type (1 bit)	Sec. Hdr. Flag (1 bit)	App. ID (11 bits)	Seq. Flags (2 bits)	Seq. Count (14 bits)					

Table 5-4: Host Vehicle-to-NDS Command Packet Parameters

Field Name	Size	Values	Description
Version	3 bit	0	CCSDS packet version '000'.
Type	1 bit	1	1 identifies command packets.
Sec Hdr Flag	1 bit	1	1 indicates a secondary header.
Application ID	11 bits	0	Currently unused, may be used later to determine command source.
Segmentation Flag	2 bits	0x11	Will be 0x11 to indicate an unsegmented packet.
Source Seq Count	14 bits	0-16383	Packet sequence counter.
Packet Data Length	16 bits	51	This 16-bit field shall contain a length count C that equals one fewer than the length (in octets) of the packet data field. The length count C shall be expressed as: $C = (\text{total number of octets in the Packet Data field}) - 1$.
Timestamp	64 bits	32-bit Seconds field and 32-bit Micro-seconds field	Currently, a relative timestamp from when the processor is powered on. Used for data logging and debugging.
Command ID	16 bits	Table 3.2.1.5.3-1	Commands will have a minimum hamming distance of 3 to eliminate the possibility of incorrect command execution with up to two bit flip errors in the CID.
Reserved	16 bits	0	Reserved field (currently used to keep 32-bit alignment).
Payload	40 Bytes	Defined in Appendix D	The payload will consist of 10 command arguments (32-bit) data fields.

The H&S packet will be used to send periodic H&S data to the host vehicle at a rate of 50 Hz. This data will include command responses and measurements. The H&S packet has a max size of 1024 Bytes. See Table 5-5: NDS-to-Host Vehicle H&S Packet for details. See Table 5-6: NDS-to-Host Vehicle H&S Packet Parameters for parameter definitions.

Table 5-5: NDS-to-Host Vehicle H&S Packet

Primary Header					Packet Data Field					
Packet Version (3 bits)	Packet Identification			Packet Seq. Control		Packet Data Length (16 bits)	Secondary Header			Payload (1000 Bytes Max)
	Type (1 bit)	Sec. Hdr. Flag (1 bit)	App. ID (11 bits)	Seq. Flags (2 bits)	Seq. Count (14 bits)		Time-stamp (64 bits)	Cmd Resp ID (16 bit)	Cmd Resp Type (8 bits)	

Table 5-6: NDS-to-Host Vehicle H&S Packet Parameters

Field Name	Size	Values	Description
Version	3 bit	0	CCSDS packet version '000'.
Type	1 bit	0	0 identifies telemetry packets.
Sec Hdr Flag	1 bit	1	1 Indicates a secondary header.
Application ID	11 bits	Defined in Table 5-8	Used to indicate packet such as H&S, Configuration, etc.
Segmentation Flag	2 bits	0x11	Will be 0x11 to indicate an unsegmented packet.
Source Seq Count	14 bits	0-16383	Packet sequence counter.
Packet Length	16 bits	1011 (H&S packet) 235 (config packet)	This 16-bit field shall contain a length count C that equals one fewer than the length (in octets) of the Packet Data field. The length count C shall be expressed as: $C = (\text{total number of octets in the Packet Data field}) - 1$.
Timestamp	64 bits	32-bit Seconds field and 32-bit Micro-seconds field	Currently, a relative timestamp from when the processor is powered on. Used for data logging and debugging.
Command Response ID	16 bits	Defined in Appendix C	Command ID of the command being reported on.
Command Response Type	8 bits	Defined in Table 5-9	Command response such as Valid, Invalid, Received, and Executed.
Reserved	8 bits	0	Reserved field (currently used to keep 32-bit alignment between secondary header and payload).
Payload	998 Bytes Max	Defined in Appendix D	H&S payload packet defined in the MSID list.

The H&S packet can be used for different types of data transfer. These types and sizes will be predefined in the following table. The configuration parameter packet will be sent to the host vehicle at a rate of 1 Hz when the NDS software is in Safe mode and the configuration state. The configuration packet will replace the final H&S packet in a major frame. The packet type identifier will be created using a minimum hamming distance of 3, which will ensure that more than two bit flips would be required to misrepresent a packet type. See Table 5-7: NDS-to-Host Vehicle H&S Packet Types for details.

Table 5-7: NDS-to-Host Vehicle H&S Packet Types

Packet Name	Packet Type ID	Packet Size (without frame)	Description
Periodic H&S	0x07	1018 Bytes	The periodic H&S packet will be transmitted at 50 Hz, and will be the default packet used for FDIR and command response.
Configuration Parameters	0x19	242 Bytes	The configuration parameter packet will be transmitted either when requested or when parameter changes are commanded.

Command responses will be transmitted using the command response and response type data fields of the H&S packet. The command response will be transmitted once per command received. Command response history can be obtained in the H&S payload data. See Table 5-8: NDS-to-Host Vehicle H&S Command Response Types for details.

Table 5-8: NDS-to-Host Vehicle H&S Command Response Types

Response Name	Response Type ID	Description
Command Received	0x07	Command response to indicate the command has been received.
Command Valid	0x19	Command response to indicate the command id, parameters, state/mode are valid.
Command Invalid	0x1E	Command response to indicate either the command id, parameters, state/mode are invalid.
Command Executed	0x2A	Command response to indicate the command has been executed.

The NDS uses a transfer frame format that includes a sync marker and a 16-bit CRC for Transmit (TX) and Receive (RX) messages. The maximum size of the packet including the payload and transfer frame overhead is 1024 Bytes. See Table 5-9: Transfer Frame Packet Structure for details. See Table 5-10 for parameter definitions.

Table 5-9: Transfer Frame Packet Structure

Frame Header	Payload Data Field	Frame Trailer
Sync Marker (32 bit) 1ACFFC1D	CCSDS Packet (H&S – 1018 Bytes) (CONFIG – 242 Bytes) (CMD – 58 Bytes)	CRC (16 bit)

Table 5-10: Transfer Frame Parameter Definitions

Name	Size	Values	Description
Sync Marker	32 bit	1ACFFC1D	Sync Marker is a 32-bit data field used to indicate the beginning of a packet.
Payload	1018 Byte Max	Tables 5-2 and 5-4	Payload packet defined above in Tables 5-2 and 5-4.
CRC	16 bit	Variable	CRC-CCITT defined in Table 5-11.

The CRC field will be used to ensure that the message was not corrupted during transmission. The CRC-CCITT algorithm has been chosen due to its popularity among other protocols such as HDLC and CCSDSs. The CRC is calculated for the entire length of the payload data field excluding the sync marker and CRC. See Table 5-11: CRC-CCITT Parameters for details.

Table 5-11: CRC-CCITT Parameters

Algorithm:	CRC-CCITT
Width:	16 bits
(Truncated) Polynomial:	0x1021
Initial Remainder:	0xFFFF
Final XOR Value:	0x0000
Reflect Data:	No
Reflect Remainder:	No

5.4.3 NDS Data Transfer

The NDS will transmit packets using two independent serial data (TIA-422-B) command/control paths from the host vehicle as system A and system B. See Table 5-12: NDS-to-Host Vehicle C&DH Interface Layers for details. The data will be transferred in network byte order (Big Endian).

Table 5-12: NDS-to-Host Vehicle C&DH Interface Layers

Layer No.	C&DH Interface Layers	Implementation
5, 6, 7	Data Layer – C&DH Packets	See Tables 5-2 and 5-4.
3, 4	Network/Transport Layer – Transfer Frame Packet	See Table 5-8.
2	Data Link Layer – Frame UART definition	921.6 K baud, 8 bits data, no parity, 1 start bit, 1 stop bit, no flow control.
1	Physical Layer – TIA-422-B	4-wire + return + shield.

The NDS will transmit and receive data to/from the host vehicle at 921.6 K bits/sec. The bit rate will be fixed.

5.4.4 Command List

The command list is maintained in an attached file to this IDD (Refer to APPENDIX C). The commands list contains detailed command information such as valid mode/state, CID, parameters, and valid ranges. CIDs are created using a minimum Hamming distance of 3, which will ensure that more than two bit flips would be required to misrepresent a CID.

5.4.5 Measurement List

The measurement list is maintained in an Excel spreadsheet and is part of this IDD. The measurement list contains Measurement Stimulation Identification (MSID), data range, measurement type, size, and units. Refer to APPENDIX D for the measurement list.

5.5 NDS-to-Host Vehicle Connectors Locations

This section defines the NDS-to-host connector location. Refer to Section 5.3 for electrical interface details. Refer to Figure 5-13: NDS (excluding -302) to Host Vehicle Electrical Interface through Figure 5-15: NDS (excluding -302) Tunnel Connections-to-Host Vehicle Electrical Interface [R.LIDS.5036] for NDS-to-Host Vehicle connector locations.

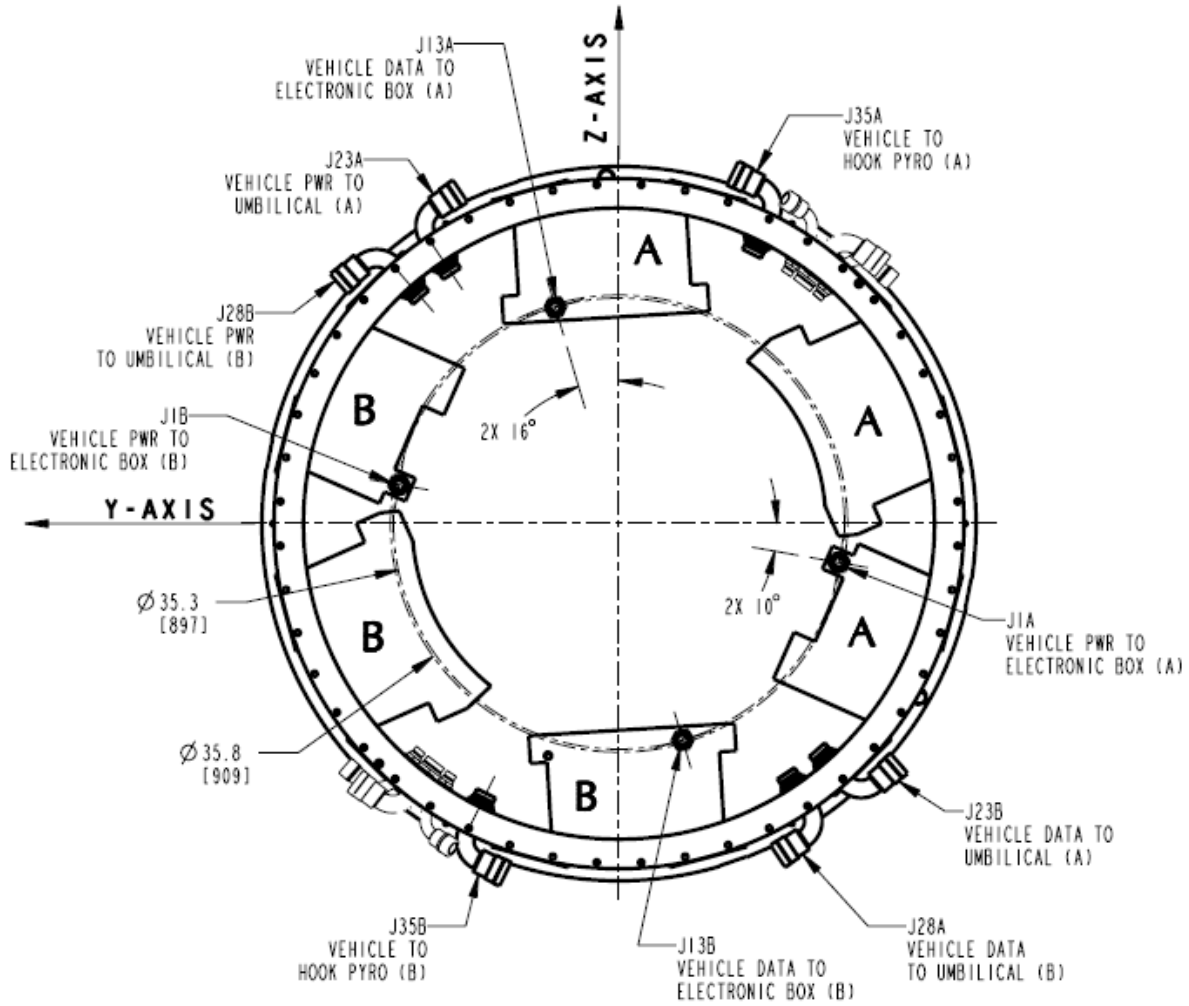

Note: Pyro connectors are excluded from -304.

Figure 5-13: NDS (excluding -302) to Host Vehicle Electrical Interface

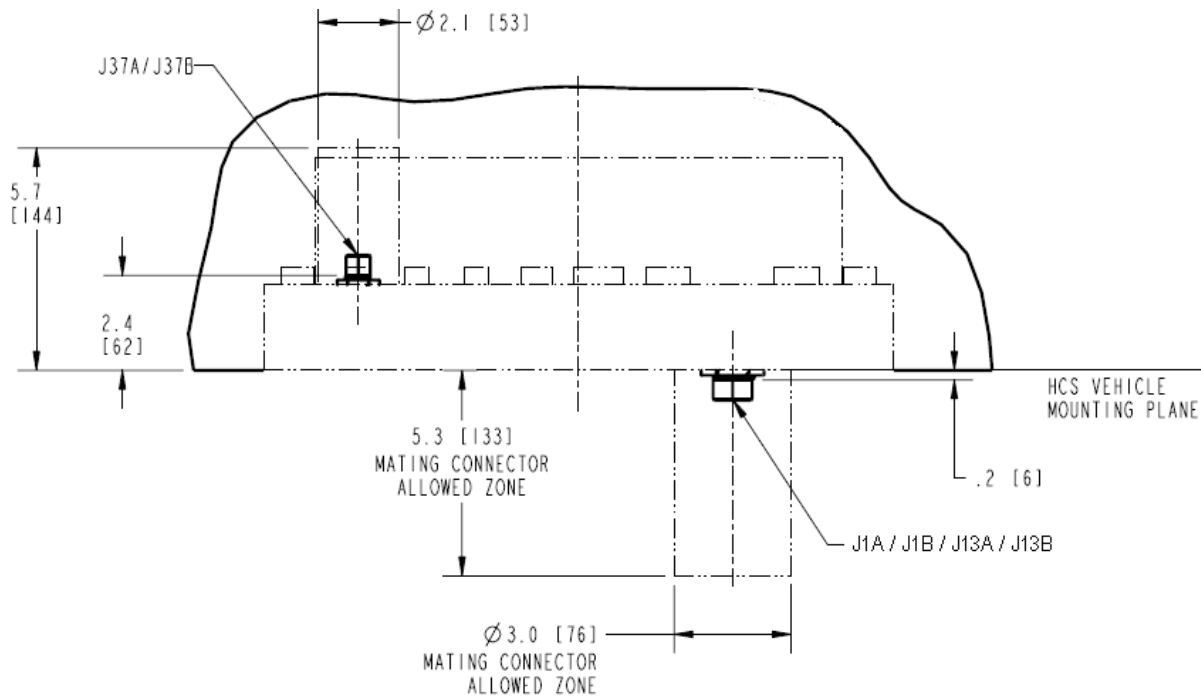
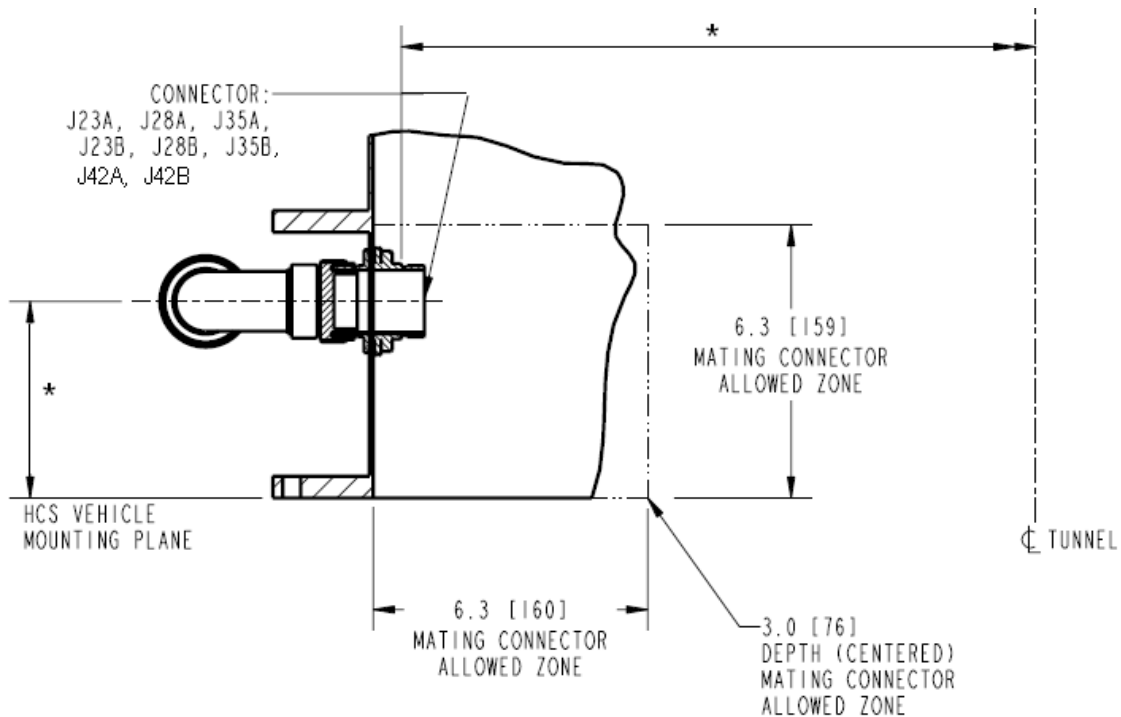
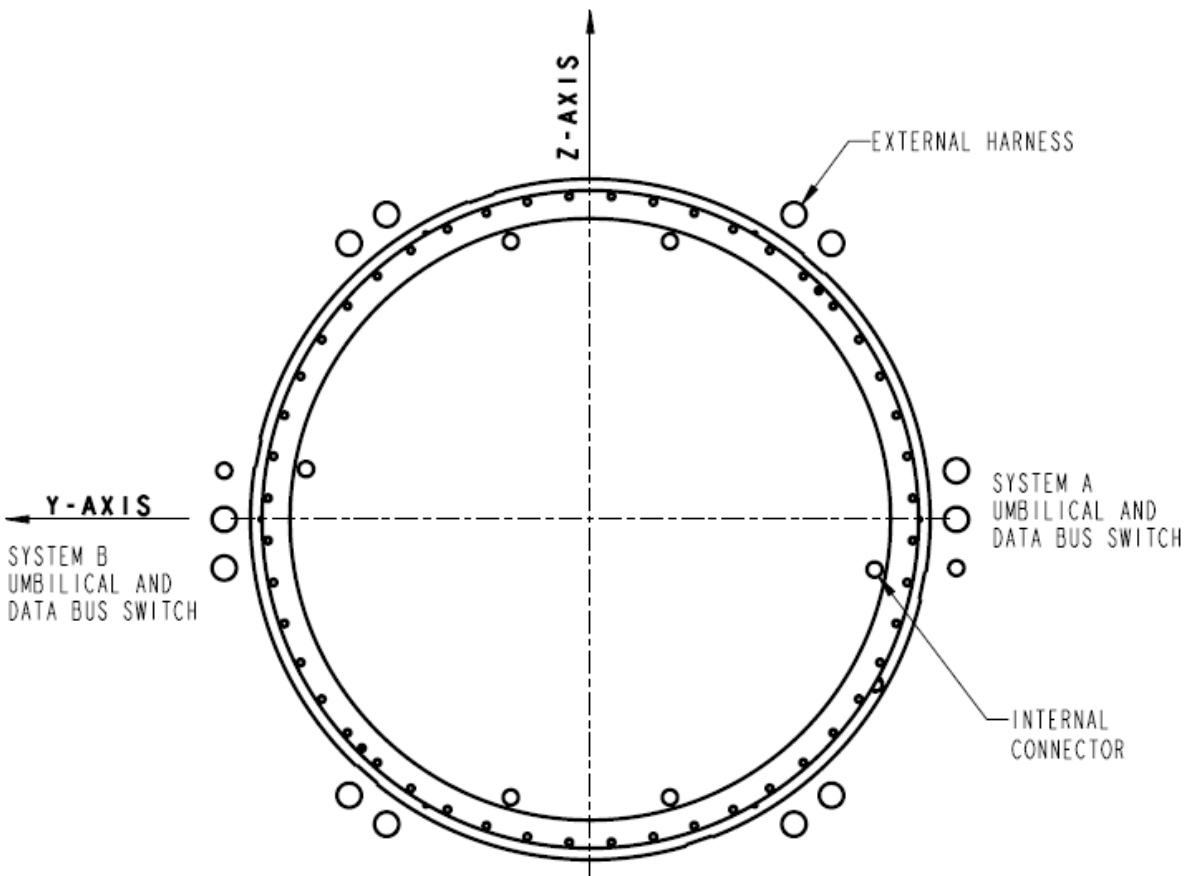

Figure 5-14: NDS (excluding -302) Box Connections-to-Host Vehicle Electrical Interface



Note: *TBD-50 for future definition of elevation of host interface connectors.

Figure 5-15: NDS (excluding -302) Tunnel Connections-to-Host Vehicle Electrical Interface [R.LIDS.5036]



Notes:

View looking at NDS mounting flange from the host.

The following items are TBD-51:

- External harness strain relief locations
- External harness various lengths
- Interface between host-provided harnesses and Umbilical Assembly
- External and Internal connector locations and quantity

Figure 5-16: NDS (-302)-to-Host Vehicle Electrical Interfaces

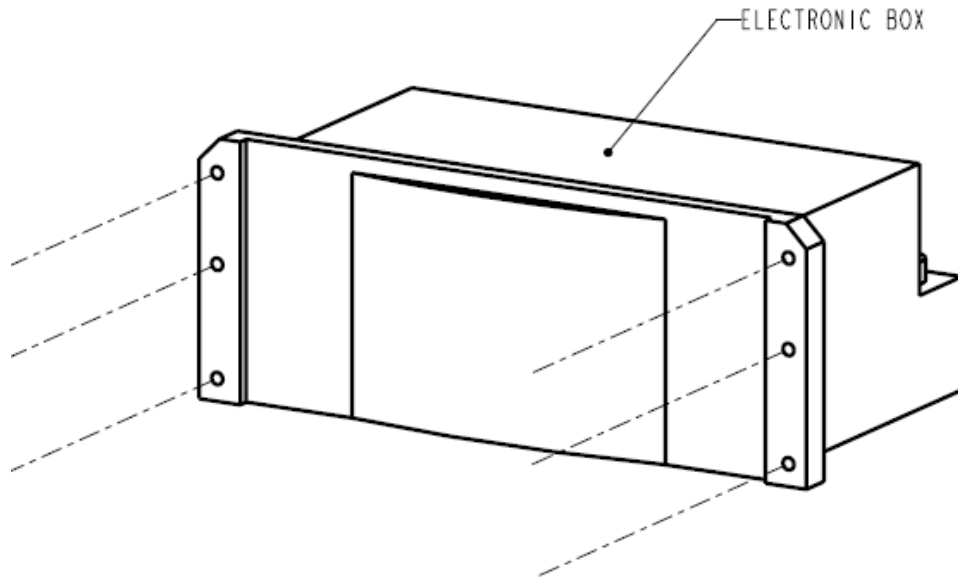

Notes:

- Mounting interface: TBD-49
- Box dimensions: TBD-49
- Box mass properties: TBD-49
- Keep-Out zones for connector access: TBD-49

Figure 5-17: NDS (-302) Remote Electrical Boxes

5.5.1 NDS (excluding -302) Power Transfer Interface to Host Vehicle Connector Location

Refer to Section 4.3.1 for a description of NDS power transfer capability and Section 5.3.1 for a description of the power transfer electrical interface to the host vehicle.

5.5.1.1 NDS (-302) Power Transfer Interface to Host

The NDS (-302) power transfer host interface is a connector in line below the umbilical mechanism connector, located at the ISS Passive NDS interface to the CDA tunnel. Refer to Figure 5-17: NDS (-302) Remote Electrical Boxes.

5.5.2 NDS (excluding -302) Data Transfer Interface to Host

Refer to Section 4.3.1 for a description of NDS data transfer capability and Section 5.3.2 for a description of the data transfer electrical interface to the host. Refer to Interface and Interface for the location of the connector to the host interface.

5.5.2.1 NDS (-302) Data Transfer Interface to Host

The NDS (-302) Data transfer host interface is a connector in line below the umbilical mechanism connector, located at the ISS Passive NDS interface to the CDA tunnel. Refer to Figure 5-16: NDS (-302)-to-Host Vehicle Electrical Interfaces.

5.5.3 Water Transfer

The NDS may add water source and water transfer as a future block upgrade capability.

5.5.4 Fuel Transfer

The NDS may add fuel transfer as a future block upgrade refueling capability.

5.5.5 Pressurant Transfer

The NDS may add tank pressurization for fuel and oxidizer transfer as a future block upgrade capability.

5.5.6 Oxidizer Transfer

The NDS may add oxidizer transfer as a future block upgrade refueling capability.

6.0 NDS-TO-GROUND SUPPORT EQUIPMENT INTERFACE

The NDS contains features built in to accommodate Ground Support Equipment (GSE) interfaces for attaching lifting hardware, seal protective covers, bell jars, and electrical connector for 6-1 handling & HD.

6.1 Structural/Mechanical

6.1.1 Lifting Interface

Refer to Figure 4-12 for details showing lift points. The lift points are designed for a vertical lift only and requires the use of a NDSP provided spreader bar.

6.1.2 Seal Cover Interface

NDSP provided Upper and lower seal covers will provide protection for the seals during handling and shipping of the NDS hardware.

The upper seal protective cover attaches to the upper seal surface of the NDS through the six .375-16 lift attach points per Figure 4-13: HCS Docking Interface [R.LIDS.0029]. When lifting the NDS, the seal cover attach fasteners are replaced with the lift hardware at the lift attach points. It is not necessary to remove the upper seal cover to use the lift hardware.

The lower seal cover attaches to the NDS lower surface through the NDS-Host Vehicle mounting interface holes per Figure 5-3.

6.1.3 Pressure Dome Interfaces

NDSP provided Upper and lower pressure domes will be used for seal leak tests during ground testing. In addition to ground testing of seal leaks, the upper pressure dome will be used for leak testing of the upper seal while mounted to a vehicle.

The upper dome will attach to the NDS by engaging the NDS passive hook with a manually activated hook on the pressure dome side. The upper pressure dome includes pins and sockets to align with the NDS alignment pins. Figure 4-13 shows the specifics on alignment pin and hook locations.

The lower pressure dome that will be used in ground testing of the NDS will attach to the NDS through the 48 NDS-to-vehicle bolt pattern. Refer to Figure 5-3.

6.1.4 Pressure Seal Interface, Pass-Through Connectors

The NDS pass-through connectors are designed to accommodate bell jars to measure leaks around pass-through connectors during ground tests. The surface surrounding the connectors on the outside of the tunnel provide a flat surface for the sealing of the bell jar to the tunnel.

6.1.5 Pressure Seal Interface, Test Ports

Two pressure test ports are located on the NDS lower seal to provide the capability to perform individual seal leak tests of the lower seal surface both on the ground and

while integrated to a vehicle. The ports are located 180 degrees apart with access from the outside of the NDS tunnel. NDSP provides GSE to support leak testing. Refer to Figure 6-1: Leak Test Port Locations, Figure 6-2: Leak Test Port Cross Section, and Figure 6-3: Leak Test Port Detail.

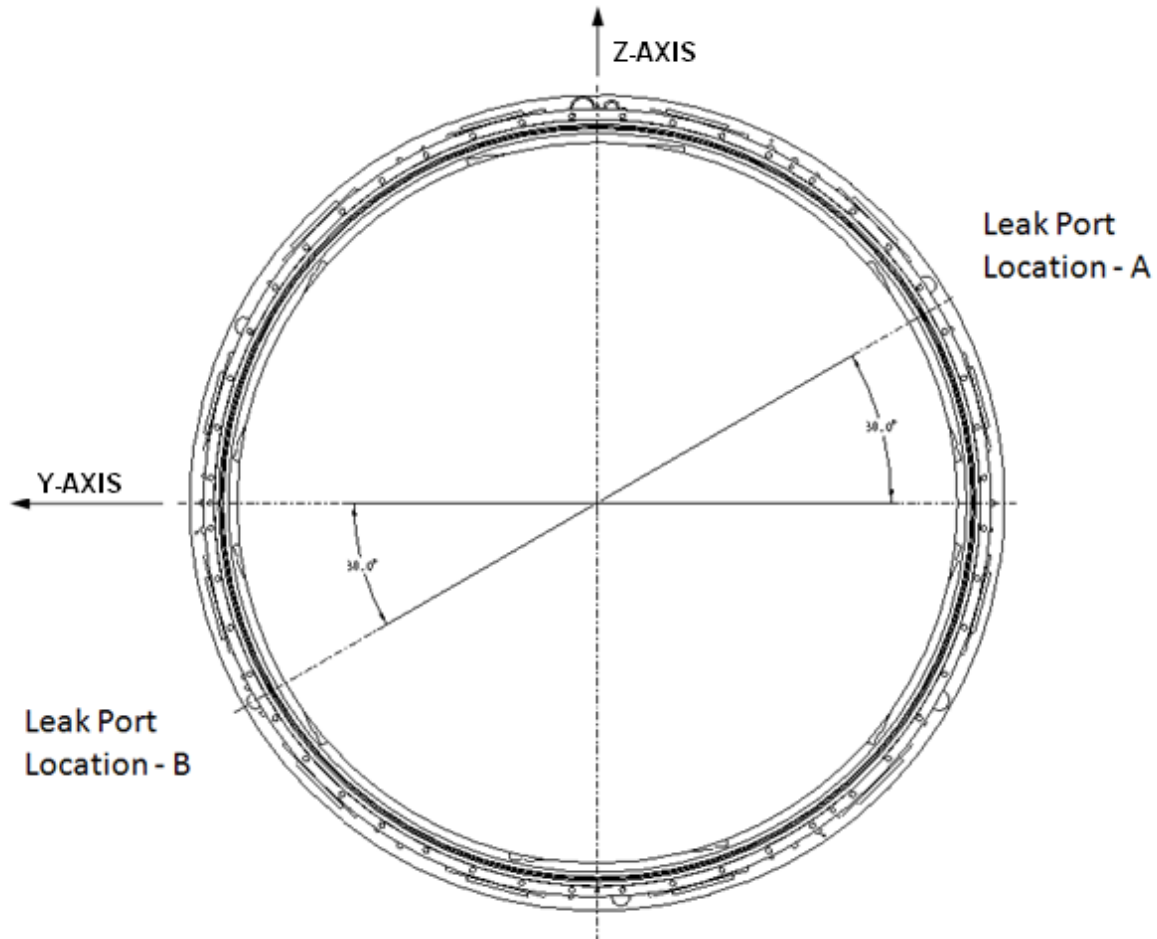

Figure 6-1: Leak Test Port Locations (excluding -302)

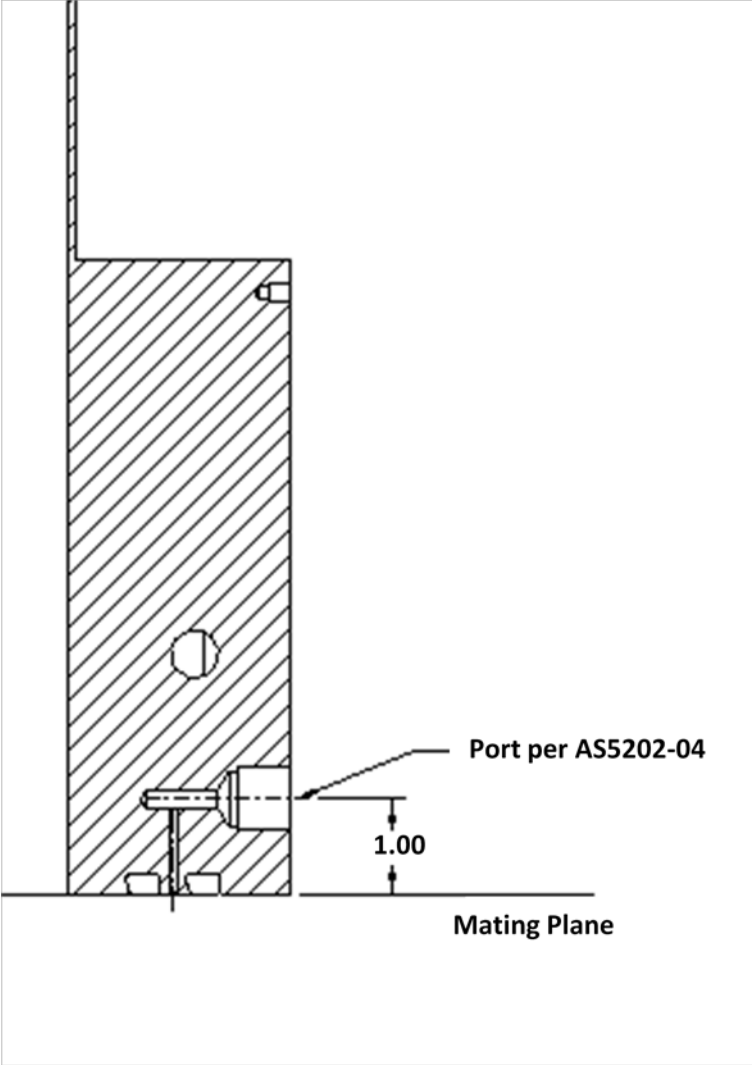
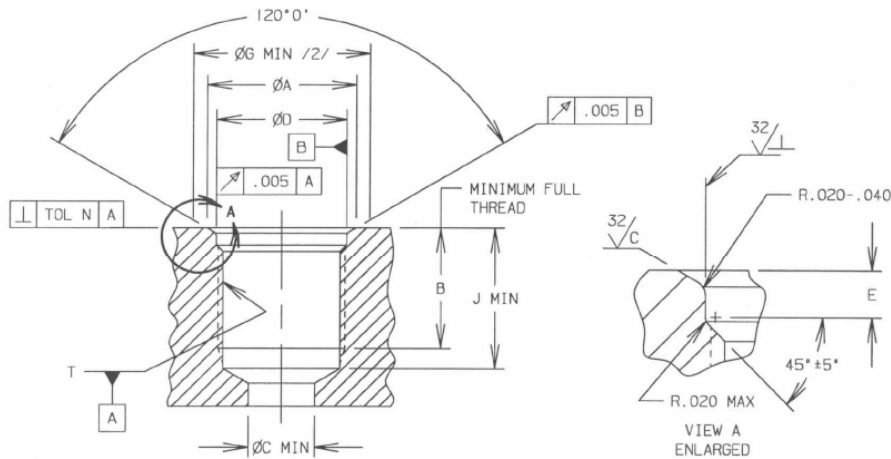

Figure 6-2: Leak Test Port Cross Section



BASIC NO. AS5202	(NOMINAL TUBE SIZE)	T THREAD PER AS8879 CLASS 3B	A	B	C	D	E	G	J	N		
/9/ SIZE CODE 04	.250	.4375-20-UNJF	-.000/+0.015	.562	.568	.172	-.000/+0.005	.454	.075	.728	.656	.003

Figure 6-3: Leak Test Port Detail

6.1.6 Handling Fixture Interface

The NDSP provided handling fixtures interface to the NDS through the 48 NDS-to-vehicle bolt pattern as shown in Figure 6-4: Handling Fixture Interface to NDS Bolt Pattern. The lower seal cover will remain on the NDS while using the handling fixture providing protection to the seals.

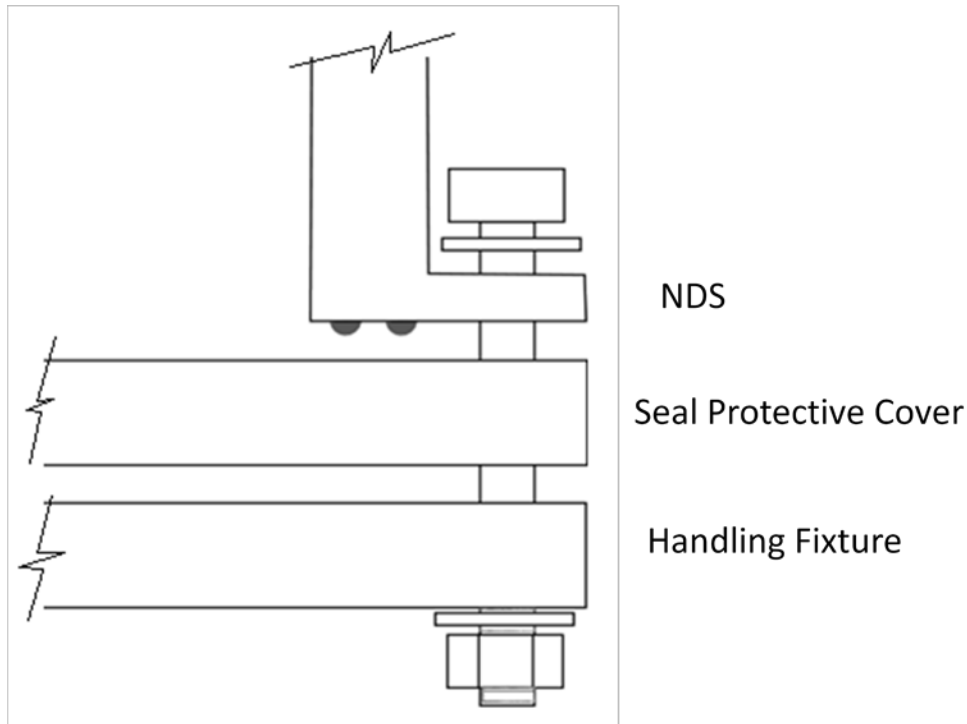

Figure 6-4: Handling Fixture Interface to NDS Bolt Pattern

6.1.7 Instrument Checkout

The NDS will use a sensor ring to simulate docking during ground testing. The sensor ring will be equipped to activate capture sensor for functional validation prior to flight. The sensor ring will interface to the NDS through the six .375-16 lift attach points specified in Figure 4-13.

6.2 Electrical Interfaces for Command and Data Handling

The NDS assembly will provide a dedicated GSE connector on the NDS control box. NDS will provide GSE software with a Graphical User's Interface (GUI) for an engineering evaluation of the unit via the dedicated GSE connector. The GSE software can be run on a standard laptop and will allow commanding as well as H&S data viewing. Refer to Figure 5-13.

7.0 HOST REQUIREMENTS FOR NASA DOCKING SYSTEM INTEGRATION

This section defines the requirements the host must meet in order to control integrated host/NDS hazards and/or specific host requirements to integrate the NDS. The References column indicates the IDD section or PTRS requirement related to the host requirement. The mechanism for invoking these requirements on the host vehicle will be determined in the future. The NDSP is not responsible for verification of these requirements.

Host Requirement ID	Requirement	References
R.LIDS.6000	To prevent injury due to accidental violation of the NDS keep out zone (as well as preventing connector damage), the vehicle supplying umbilical power shall provide a minimum of 3 inhibits to prevent voltage from being present on the exposed terminals.	4.3.1, 5.3.1
R.LIDS.6001	The host vehicle firing circuitry shall provide a minimum of 3 inhibits to protect against inadvertent firing. Inhibits are controlled by switches with guards and/or multi-step commanding to prevent inadvertent inhibit removal.	5.3.3
R.LIDS.6002	The host vehicle shall ensure that vehicle/mission-specific loads are all enveloped by the NDS designed-to loads.	4.1.4
R.LIDS.6003	The host shall use the locking insert KNML10 x 1.5T for the structural interface to NDS to ensure back out prevention.	Figure 5-3 Notes 1 and 6
R.LIDS.6004	The host vehicle shall provide circuit protection to ensure the NDS power cables and connectors upstream of the NDS circuit protection will not overheat.	Figure 5-13 and APPENDIX F
R.LIDS.6005	The host vehicle shall provide a Class R bonding path through the base of the NDS tunnel.	5.3.8
R.LIDS.6006	The host vehicle shall maintain NDS within its operating and non-operating temperature limits.	4.1.1, 5.2.3 , 5.3.6
R.LIDS.6007	The host integrating -302 electrical boxes shall provide a minimum thermal contact conductance of 1.04 Btu/hr-°F at each of the two mounting interfaces per box for the metal-to-metal contact area such that maximum interface temperature is 122 °F.	5.2.3.1
R.LIDS.6008	The host vehicle shall respond to NDS heater H&S message anomalies (including lost and	5.3.6

Host Requirement ID	Requirement	References
	corrupted H&S message) in accordance with the NDS heater failure response matrix.	
R.LIDS.6009	The host vehicle shall maintain all NDS surfaces Visibly Clean (VC) Sensitive and NDS seals VC Highly Sensitive following receipt for integration.	4.1.1.2.3 and 5.2.2
R.LIDS.6010	The host vehicle shall ensure that the contamination constituents and quantities deposited on the NDS do not exceed SSP 30426, Space Station External Contamination Control Requirements.	R.LIDS.0096
R.LIDS.6011	The host vehicle shall protect NDS from primary lightning effects (i.e. lightning direct current path) and limits secondary effects to within the NDS Safe Operation Level (SOL).	5.3.5.1, Figure 5-9
R.LIDS.6013	The host vehicle shall verify the NDS soft capture system is locked down for launch using NDS telemetry.	APPENDIX D
R.LIDS.6014	The host vehicle shall supply power within the NDS capability to operate.	5.3.4
R.LIDS.6015	The host vehicle shall ensure that any potential radio frequency transmitters are incapable of radiating NDS pyrotechnic circuitry with sufficient energy to induce a current in the firing circuit capable of igniting a NASA Standard Initiator (NSI).	5.3.3
R.LIDS.6016	The host vehicle's firing circuitry shall supply sufficient power for a sufficient duration to ignite each of the 24 NDS pyrotechnics within TBD-40 ms ensure they disengage in synchronization.	5.3.3
R.LIDS.6017	The host vehicle shall ensure that the NDS pyrotechnics have sufficient life remaining to perform the desired mission.	5.3.3
R.LIDS.6047	The host vehicle shall ensure that the NDS vestibule is depressurized prior to pyrotechnic separation of the NDS hooks.	5.3.3
R.LIDS.6018	The chaser vehicle shall approach the target vehicle within the NDS soft capture envelope.	Table 4-1
R.LIDS.6019	The host vehicle Guidance, Navigation, and Control (GN&C) for the NDS in active mode shall transition into free drift within TBD seconds of receipt of the "initial contact" indication in the NDS H&S message from either system A or	4.1.2.7

Host Requirement ID	Requirement	References
	system B. The host vehicle will be 2-Fault Tolerance (FT) to a failure to receive the initial contact indication via the serial communications link with NDS.	
R.LIDS.6020	The host vehicle shall detect a loss or corruption of the serial link and notify the vehicle's computing system of the failures. Loss of serial communications to both NDS systems in a docking attempt results in a docking attempt abort.	4.1.2.7
R.LIDS.6021	The host vehicle shall be 2-FT to inadvertent thruster firing during "free drift" period.	4.1.2.7
R.LIDS.6022	The host vehicle GN&C for the NDS in passive mode shall transition to free drift within TBD seconds of receipt of the soft capture indication. The two vehicle combined will be 2-FT to a failure to receive the soft capture indication.	4.1.2.7
R.LIDS.6023	The host vehicle with the passive mode NDS shall receive the soft capture indication from either NDS system A, NDS system B or from an RF link from the vehicle with the active NDS. The two docking vehicles establish an RF communications path by which the vehicle with the active docking mechanism can provide the vehicle with the passive mechanism an additional soft capture indication.	4.1.2.7
R.LIDS.6024	The host vehicle shall send NDS the commands to power on and dock. Then, at the final GN&C transition to docking approach (30 meters distance – TBD), the host vehicle shall send NDS the "Capture" command. –	5.4.1.1
R.LIDS.6025	The host shall allow for 5 seconds of free drift during NDS calibration in preparation for docking.	N/A
R.LIDS.6026	The host vehicle shall respond to NDS failure indications (including loss of H&S message or a corrupted/repeating H&S message) per the FDIR logic tables in 1.1.1.1.1.1.1 APPENDIX A.	5.4.1.3, 1.1.1.1.1.1.1 APPENDIX A
R.LIDS.6027	The host vehicle shall provide the capability to remove power from NDS and abort a docking attempt in the event that NDS system A and system B have experienced a failure and in certain other failure scenarios. The docking attempt abort criteria are contained in the FDIR	5.4.1.3

Host Requirement ID	Requirement	References
	logic tables in the NDS IDD.	
R.LIDS.6028	The host vehicle shall separate the actions required to enable power to NDS such that enabling of NDS motor power and NDS control system power are never combined into a single command or crew action or could be activated by a single failure.	5.4.1.1
R.LIDS.6029	The host vehicle shall separate the actions required to command NDS to undock such that the Enable Undock and Execute Undock commands are never scripted together in the host vehicle software.	5.4.1.1
R.LIDS.6030	<p>In order to preclude a catastrophic inadvertent undocking, to the host vehicle shall ensure power is removed from both NDS systems A and B prior to unlocking the hatch on either side of the docking vestibule.</p> <p>The host vehicle shall inhibit power NDS systems A and B until the hatches on both sides of the docking vestibule are closed and confirmed to be locked.</p>	TBD
R.LIDS.6031	The host vehicle shall provide the capability to recover from an uneven departure using its GN&C sensors and thrusters to prevent a collision from occurring. Refer to JSC-63844, NDS Capture Performance Data Book.	N/A
R.LIDS.6032	The host vehicle shall provide an independent means (outside of NDS) of confirming that undocking is complete. The host vehicle will enable its GN&C active control when either system A, system B, or the independent means indicates that undocking is complete.	4.1.3.6
R.LIDS.6033	The host vehicle provides separate power strings to NDS system A, system B, and pyrotechnics controller such that a single power system failure cannot eliminate more than one NDS undocking functional path.	Figure 5-13, APPENDIX F
R.LIDS.6034	The host vehicle shall limit the interface loads to values as defined in JSC-65970, iLIDS Thermal and Induced Environments.	R.LIDS.0102
R.LIDS.6035	The host vehicle shall limit the depressurization rate to 0.76 psi/sec (5.24 kPa/sec) over the range of 15.2 psia (104.8 kPa) to 5.5E-12 psia (2.7E-10 Torr).	R.LIDS.0103

Host Requirement ID	Requirement	References
R.LIDS.6036	The host vehicle shall limit the repressurization rate to 0.30 psi/sec (2.07 kPa/sec) repressurization rate over the range of 5.5E-12 psia (2.7E-10 Torr) to 15.2 psia (104.8 kPa).	R.LIDS.1118
R.LIDS.6037	The two mated host vehicles together will provide a minimum of 2-FT to an inability to depressurize the docking vestibule.	R.LIDS.6053, R.LIDS.6054
R.LIDS.6038	The host vehicle shall provide an indication to the mated host vehicle that NDS has failed to gain structural integrity.	4.1.3.4, 4.1.3.5
R.LIDS.6039	The two host vehicles shall each have active hooks.	4.1.3.4
R.LIDS.6040	The host integrating NDS (-302) shall provide MMOD shielding for NDS (-302) to meet vehicle Probability of No Penetration (PNP) requirements.	3.1, 5.2.3
R.LIDS.6041	The host integrating NDS (-302) shall provide external TPS for NDS (-302).	5.2.3
R.LIDS.6042	The host integrating NDS (-302) shall provide mounting provisions for NDS (-302) electrical boxes.	5.3.4
R.LIDS.6043	The host integrating NDS (-302) shall provide connectors and cable restraint as required per host mounting implementation of NDS (-302) electrical boxes.	5.3.4
R.LIDS.6044	The host integrating NDS (-302) shall provide passage way TPS and closeout for NDS (-302).	3.1
R.LIDS.6045	The mating host vehicle shall provide separators for undocking separation redundancy.	4.1.3.7
R.LIDS.6046	The mating host vehicle shall provide class-R/H bond at the NDS-to-NDS vehicle interface.	4.2.1.1.1
R.LIDS.6048	The host integrating NDS (-302) shall provide class-R/H bond at the NDS electrical box-to-host vehicle interface.	Figure 5-17
R.LIDS.6049	The host vehicle will limit NDS seals' cumulative exposure to ultraviolet below 214 (TBR-212) "sun hours" equivalent.	R.LIDS.0202 R.LIDS.1113

APPENDIX A Acronyms and Abbreviations

Btu	British Thermal Units
C&DH	Command and Data Handling
CCSDS	Consultative Committee for Space Data Systems
CDA	Common Docking Adapter
CE	Complex Electronics
CID	Command ID
CRC	Cyclic Redundancy Check
C&T	Communication and Tracking
°C	Degrees Celsius
°F	Degrees Fahrenheit
deg/sec	Degrees per Second
DEM	Data Exchange Message
E3	Electromagnetic Environmental Effects
ECLSS	Environmental Control and Life Support System
FOD	Foreign Object Debris
FT	Fault Tolerance
ft/sec	Feet per Second
FDIR	Fault Detection, Isolation, and Recovery
D&C	Display and Control
EMC	Electromagnetic Compatibility
FRAM	Flight Releasable Attachment Mechanism
ft ³	Cubic Feet
GN&C	Guidance, Navigation, and Control
GSE	Ground Support Equipment
GUI	Graphical User's Interface
H&S	Health and Status
HCS	Hard Capture System
HDLC	High-Level Data Link Control
hPa	Hecto Pascal(s)
I/F	Interface

ICD	Interface Control Document
ID	Internal Diameter or Identification
IDD	Interface Definition Document
IDSS	International Docking System Standard
iLIDS	International Low Impact Docking System
IRD	Interface Requirements Document
ISS	International Space Station
IVA	Intravehicular Activity
kg	Kilogram(s)
kgf	Kilograms Force
kPa	Kilo Pascal(s)
lb	Pound(s)
lbf	Pound sForce
lbm	Pounds Mass
LIDS	Low Impact Docking System
m ³	Cubic Meters
MLI	Multi-Layer Insulation
MMOD	Micro Meteoroid Orbital Debris
ms	Millisecond(s)
m/s	Meters per Second
MSID	Measurement Stimulation Identification
N	Newton(s)
Nm	Newton-Meter(s)
NASA	National Aeronautics and Space Administration
NDS	NASA Docking System
NDSP	NASA Docking System Project
NSI	NASA Standard Initiator
OD	Outer Diameter
PCT	Post Contact Thrust
PDU	Power Distribution Unit
PEC	Pyrotechnic Even Controller
PIC	Pyrotechnic Initiator Controller

P/N	Part Number
PNP	Probability of No Penetration
psi	Pounds per Square Inch
PTRS	Project Technical Requirements Specification
RF	Radio Frequency
RPC	Remote Power Controller
RT	Remote Terminal
RTH	Ready to Hook
RX	Receive
SCS	Soft Capture System
SI	System International
SOA	Safe Operating Area
SOL	Safety Operation Level
TBD	To Be Determined
TBR	To Be Reviewed
TPS	Thermal Protection System
TVS	Transient Voltage Suppressor
TX	Transmit
UML	Unified Modeling Language
VC	Visibly Clean
Vdc	Volts Direct Current
VM	Vehicle Manager
W	Watt(s)

APPENDIX B Definition of Terms

Reserved

APPENDIX C NDS Commands List



NDS_IDD_Appendix_
C_Command_List.xls

APPENDIX D NDS MSID



NDS_IDD_Appendix_
D_MSID_List.xls

APPENDIX E NDS Configuration Differences

Dash Number	NDS (-301)	NDS (-302)	NDS (-303)	NDS (-304)
Configuration Differences				
Status	In Development	✓	Avail on Request	Avail on Request
Specification Max Weight (lb)	750	704*	✓	711
Host Power	120 VDC	✓	28 VDC	✓
NDS Tunnel Height (in.)	15	TBD	✓	✓
Dynamic Seal	Seal	Seal Surface	✓	✓
Host Leak Check Port	NDS Tunnel	Host tunnel	✓	✓
Separator Striker Interface	Integral to NDS	TBD	✓	✓
Power/ Data Transfer I/F	Integral to NDS	On Host	✓	✓
SCS Magnet Striker	Yes	✓	✓	No
Active/Passive Hooks	12 pairs	✓	✓	12 Active Only
Pyrotechnic Hook Release	Yes	No	✓	No
Electrical Boxes Mounting	Integral to NDS	On Host	✓	✓
Electrical Cable Length/Routing	Integral to NDS	Host specific routing	✓	✓
Hermetic Pass Thru for NDS control	Integral to NDS	In Host Structure	✓	✓
MMOD Shield	Integral to NDS	Host Provided	✓	✓
Passage Way Closeout	Integral to NDS	Host Provided	✓	✓
Life	231 days	15 Years	✓	✓
Active Docking Cycles	2	Future	✓	✓
Passive Docking Cycles	50	✓	✓	None
Other Key Interfaces				
S/W Interface to Host	TIA-422-B or MIL-STD-1553	✓	✓	✓
Comm Channels to Host (NDS control and heater control)	One ea. channels A&B	✓	✓	✓
Motorized Transfer Umbilicals	Power/Data	✓	✓	✓
Motorized Separation System	Yes	✓	✓	✓
Legend				
✓	Indicates configuration is same as -301			

*The -302 mass listed does not include host supplied components (e.g. MMOD shield, TPS, etc.).

APPENDIX F Host Interface Connector Pinouts [R.LIDS.5037]



lids_connector_pino
uts_block_0_IDD_app

APPENDIX G Failure Response Tables

NDS Control System Failure Response

The host vehicle is required to perform failure recovery actions in response to various NDS failures. The recovery actions differ depending on the following:

- a) The type of failure indication. Depending on the failure mode and the NDS software mode and state, NDS will determine the appropriate failure indication to provide to the vehicle such that the vehicle can perform the appropriate recovery action. For failures NDS detects, it posts the failure indication status in the periodic H&S message provided to the host vehicle through the serial data communications link. For failures that NDS cannot detect, the vehicle will detect the failures through the integrity of the NDS H&S message that serves as a “heartbeat” Refer to section 5.4.1.3.
- b) Whether the failure indication was received from the system commanded to be Primary or from the system commanded to be Non-Primary. Refer to section 5.4.1.3.
- c) Whether a previous NDS failure has already occurred.

A **PRELIMINARY** description of the appropriate vehicle responses to NDS failures are described in the tables below:

First Failure Indication	Vehicle response if from Primary System	Vehicle Response if from Non-Primary System
“Pause” indication in H&S Message ^[1]	Vehicle commands both systems to pause for troubleshooting	Vehicle commands both systems to pause for troubleshooting
“Switch to Redundant String” indication in H&S Message	Vehicle commands Primary system to become Non-Primary and vice versa and sets software “flag” to abort on next Primary system “Switch to Redundant String”, “System Failure”, Bad H&S Message, or Incorrect Primary/Non-Primary indication.	Vehicle sets software “flag” to abort on next Primary system “Switch to Redundant String”, “System Failure”, Bad H&S Message, or Incorrect Primary/Non-Primary indication.
a) “System Failure” indication in H&S Message, OR b) Bad H&S Message (i.e. missing, invalid, or repeating message) ^[3] , OR c) Incorrect Primary/Non-Primary indication in H&S Message ^[3]	Vehicle removes power from Primary system and commands the Non-Primary System to become Primary. Vehicle sets software “flag” to abort on next Primary system “Switch to Redundant String”, “System Failure”, Bad H&S Message, or Incorrect Primary/Non-Primary indication.	Vehicle removes power from Non-Primary system. Vehicle sets software “flag” to abort on next Primary system “Switch to Redundant String”, “System Failure”, Bad H&S Message, or Incorrect Primary/Non-Primary indication.

Second Failure Indication^[2]:	Vehicle response if from Primary System	Vehicle Response if from Non-Primary System
"Pause" indication in H&S Message ^[1]	Vehicle commands both systems to pause for troubleshooting	Vehicle commands both systems to pause for troubleshooting
"Switch to Redundant String" indication in H&S Message	Vehicle removes power from both the Primary and Non-Primary systems. Vehicle then commands a docking attempt abort (i.e. back-out) maneuver.	No action taken.
a) "System Failure" indication in H&S Message, OR b) Bad H&S Message (i.e. missing, invalid, or repeating message) ^[3] , OR c) Incorrect Primary/Non-Primary indication in H&S Message ^[3]	Vehicle removes power from both the Primary and Non-Primary systems. Vehicle then commands a docking attempt abort (i.e. back-out) maneuver.	Vehicle removes power from Non-Primary system.

[1] Pause is only used by NDS when the failure experienced in a system results in a desire to pause both systems. For other failures where a single system may enter fault state and pause automatically, but no "Pause" failure indication is placed in the H&S Message, troubleshooting will only be performed if both the primary and non-primary systems enter fault state and automatically pause. In these cases, the flight or ground crews will monitor the telemetry and provide troubleshooting and corrective action commanding.

[2] Second failure means that the "flag" was previously set to command a docking attempt abort on the next indication from the Primary system of "SCS Switch", "System Failure", Bad H&S Message, or Incorrect Primary/Non-Primary.

[3] Bad H&S Message and Incorrect Primary/Non-Primary indications are not part of the NDS H&S Message and must be interpreted independently by the vehicle.

NDS Heater System Failure Response

The host vehicle is also required to perform failure recovery actions in response to various NDS heater system failures. The recovery actions differ depending on the following:

- d) The type of failure indication. NDS provides raw temperature status data and electrical current data to the host vehicle along with some heater controller health data. The host vehicle must interpret this data to detect failures and respond appropriately. Additionally, the vehicle must monitor the integrity of the heater H&S message that serves as the "heartbeat" of the heater controller.
- e) Whether the failure indication was in the same zone as a previously failed zone

A **PRELIMINARY** description of the appropriate vehicle responses to NDS heater system failures are described in the table below:

Failure Indication	Single System Failure	Redundant System Failure ^[2]
Temperatures between RTD A and RTD B in a zone differ by more than TBD-52 deg C	Vehicle commands the affected zone's minimum temperature set point to the "disable" ^[1] value	<p>Vehicle commands the affected zone's minimum temperature set point to the "disable"^[1] value.</p> <p>Vehicle C&W system notifies flight and ground crew that a heater zone can no longer be monitored for use in mission re-planning and/or troubleshooting.</p>
Either temperature on RTD A or RTD B in a zone drops below minimum temperature threshold for the applicable zone and operation scenario^[3] (indicating under temp condition)	Vehicle C&W system notifies flight and ground crew of NDS thermal excursion for use in mission re-planning and/or troubleshooting.	Vehicle C&W system notifies flight and ground crew of NDS thermal excursion for use in mission re-planning and/or troubleshooting.
Either temperature on RTD A or RTD B in a zone drops below TBD-52 deg C (indicating erroneous sensor data)	Vehicle commands affected zone's minimum temperature set point to the "disable" ^[1] value	<p>Vehicle commands the affected zone's minimum temperature set point to the "disable"^[1] value.</p> <p>Vehicle C&W system notifies flight and ground crew that a heater zone can no longer be monitored for use in mission re-planning and/or troubleshooting.</p>
Either temperature on RTD A or RTD B in a zone exceed the maximum temperature threshold for the applicable zone and operation scenario^[3] (indicating overtemp condition or erroneous sensor data)	<p>Vehicle uses heater current data from the heater H&S message to determine if a heater is inadvertently enabled and then commands the affected zone's minimum temperature set point to the "disable"^[1] value.</p> <p>Vehicle C&W system notifies flight and ground crew of NDS thermal excursion for use in mission re-planning and/or troubleshooting.</p>	<p>Vehicle commands both of the affected zones' minimum temperature set points to the "disable"^[1] value.</p> <p>Vehicle C&W system notifies flight and ground crew of NDS thermal excursion for use in mission re-planning and/or troubleshooting.</p>
Current in any zone exceeds TBD Amps	Vehicle commands affected zone's minimum temperature set point to the "disable" ^[1] value	Vehicle commands both of the affected zones' minimum temperature set points to the "disable" ^[1] value.
<p>a) Heater Controller Error indication in H&S Message, OR</p> <p>b) Bad H&S Message (i.e. missing, invalid, or repeating message)^[4]</p>	Vehicle removes heater power from affected system	<p>Vehicle removes heater power from both affected system</p> <p>Vehicle C&W system notifies flight and ground crew that a heater zone can no longer be monitored for use in mission re-planning and/or troubleshooting.</p>

[1] NDS heaters do not have a specific command to enable or disable a heater zone; rather, the minimum temperature set point is used to enable or disable a heater zone.

[2] For a failure that only affects a single zone, the responses described in the “Redundant System Failures” column of the table only apply to the worst-case failures (i.e., those failures that occur in the same zone in both systems). If the failures only affect a single zone and occur in different zones in the two heater systems, both failure responses should be the responses described in the “Single System Failures” column of the table.

[3] Maximum and minimum allowable temperatures for the various zones under various operating and non-operating conditions are defined in JSC 65978, iLIDS Thermal Data Book.

[4] Bad H&S message is not part of the NDS heater H&S Message and must be interpreted independently by the vehicle.

APPENDIX H Errata and TBD/TBR – List

This document is intended to define all the functional interfaces and their locations. However, the document is being released in parallel with the maturing interface requirements and definition. As such, there are several To Be Determined (TBD) and To Be Reviewed (TBR) values. These have been uniquely identified in the table below for closure tracking and update in future releases. The attached spreadsheet documents the comments and disposition from the NDS Baseline Review. The NDS configurations (-301, -302, -303, and -304) were added after the baseline review. This revision of the NDS IDD added known information about these configurations. However, the -302 electrical interfaces to the host is under review and will be updated as required in the next revision.



NDS_BR_IDD_Comm
ent_Spreadsheet_j.x

TBD #	Section, Figure, or Table #	Section, Figure, or Table Title
TBD-2	Table 3-1	Mass Properties – ISS Passive NDS Inertias
TBR-40	Section 5.3.3	Pyrotechnic Interface Androgynous NDS (timing)
TBR-41	Figure 4-3	Extended SCS Position Note
TBD-45	Appendix C	NDS Commands List
TBD-47	Figure 5-8	Serial communications RT Address note in Block Diagram MIL-STD-1553B Serial Communications Host Vehicle to NDS
TBD-46	Table 4-1 notes	Initial Capture Conditions
TBD-48	Table 5-1	Serial communications Heater Command Code (Hex)
TBD-49	Figure 5-17	NDS (-302) Remote Electrical Boxes
TBD-50	Figure 5-15	NDS (excluding -302) Tunnel Connections-to-Host Vehicle Electrical Interface [R.LIDS.5036]
TBD-51	Figure 5-16	NDS (-302) -to- Host Vehicle Umbilical Electrical Interfaces
TBD-52	Appendix G	Failure Response Table Temperatures
TBR-212	Section 7	TBR tied to PTRS requirements R.LIDS.0202, R.LIDS.1113