

Overview of the Turbine Based Combined Cycle Discipline

The NASA Fundamental Aeronautics Hypersonics project is focused on technologies for combined cycle, air-breathing propulsions systems to enable reusable launch systems for access to space. Turbine Based Combined Cycle (TBCC) propulsion systems offer specific impulse (Isp) improvements over rocket-based propulsion systems in the subsonic takeoff and return mission segments and offer improved safety. The potential to realize more aircraft-like operations with expanded launch site capability and reduced system maintenance are additional benefits.

The most critical TBCC enabling technologies as identified in the National Aeronautics Institute (NAI) study were: 1) mode transition from the low speed propulsion system to the high speed propulsion system, 2) high Mach turbine engine development, 3) transonic aero-propulsion performance, 4) low-Mach-number dual-mode scramjet operation, 5) innovative 3-D flowpath concepts and 6) innovative turbine based combined cycle integration.

To address several of these key TBCC challenges, NASA's Hypersonics project (TBCC Discipline) initiated an experimental mode transition task that includes an analytic research endeavor to assess the state-of-the-art of propulsion system performance and design codes. This initiative includes inlet fluid and turbine performance codes and engineering-level algorithms. This effort has been focused on the Combined Cycle Engine Large-Scale Inlet Mode Transition Experiment (CCE LIMX) which is a fully integrated TBCC propulsion system with flow path sizing consistent with previous NASA and DoD proposed Hypersonic experimental flight test plans. This experiment is being tested in the NASA-GRC 10'x10' Supersonic Wind Tunnel (SWT) Facility. The goal of this activity is to address key hypersonic combined-cycle-engine issues: (1) dual integrated inlet operability and performance issues – unstart constraints, distortion constraints, bleed requirements, controls, and operability margins, (2) mode-transition constraints imposed by the turbine and the ramjet/scramjet flow paths (imposed variable geometry requirements), (3) turbine engine transients (and associated time scales) during transition, (4) high-altitude turbine engine re-light, and (5) the operating constraints of a Mach 3-7 combustor (specific to the TBCC). The model will be tested in several test phases to develop a unique TBCC database to assess and validate design and analysis tools and address operability, integration, and interaction issues for this class of advanced propulsion systems. The test article and all support equipment is complete and available at the facility. The test article installation and facility build-up in preparation for the inlet performance and operability characterization is near completion and testing is planned to commence in FY11.



NASA

Fundamental Aeronautics Program - Hypersonics Project **Overview of the TBCC Discipline**

Mr. Scott R. Thomas, API
Mr. James F. Walker, APM

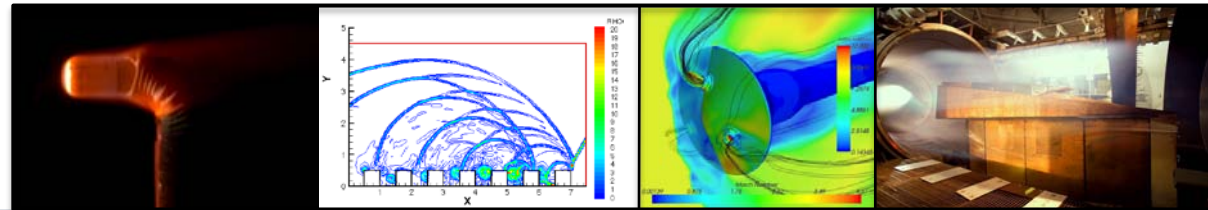

2009 Annual Meeting
September 29-October 1, 2009

TBCC Propulsion Benefits : Efficiency, Safety, Reliability



- High effective specific impulse, I_{eff}
- Horizontal takeoff and landing enhances launch, flight and ground operability
 - ✓ Benign ascent abort/engine out
- Large structural mass fraction providing large margins
 - ✓ Design for life
 - ✓ Design for safety
- Reduced sensitivity to weight growth
 - ✓ Reduced design/development risk
 - ✓ Reduced user constraints
- High payload fraction

Airbreathing Propulsion Significantly Increases Propulsion Efficiency

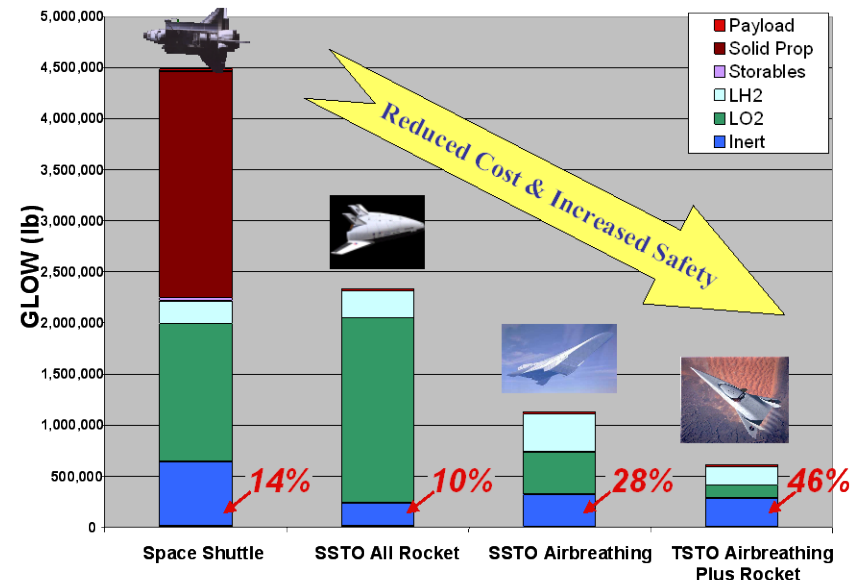
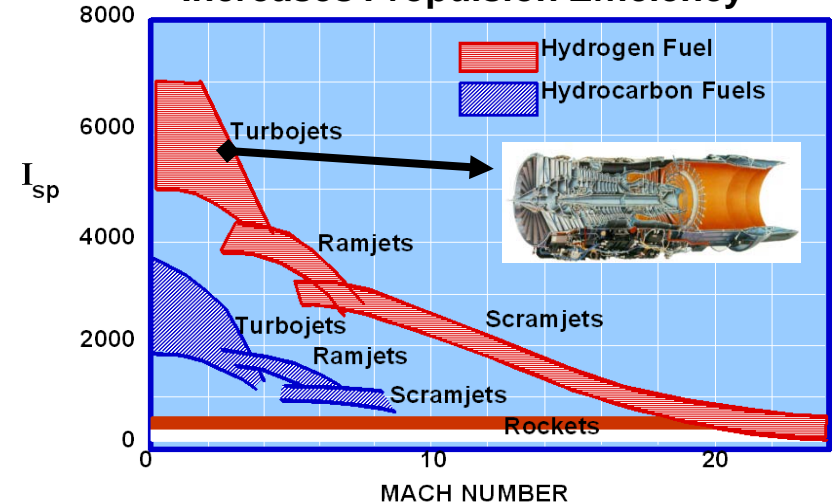

TBCC BENEFITS:

- Quick Turn Around Time (Aircraft Like Operations)
- Re- useable > 1000 missions
- Versatile Usage + Launch & Landing Sites
- Low Maintenance, High Durability, Performance Margin

$$I_{SP} = \text{Thrust/Pound per second of propellant (fuel) flow rate}$$

TBCCTechnology Challenges: *Develop Air-Breathing Propulsion Technology for Two-Stage-to-Orbit Vehicles*



Turbine Based propulsion

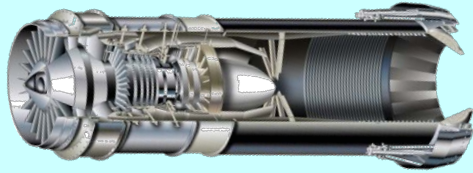

Hypersonic Scramjet propulsion

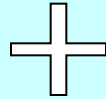
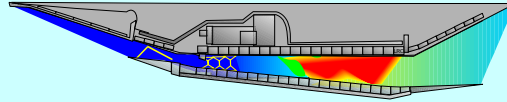

Hypersonic TBCC propulsion

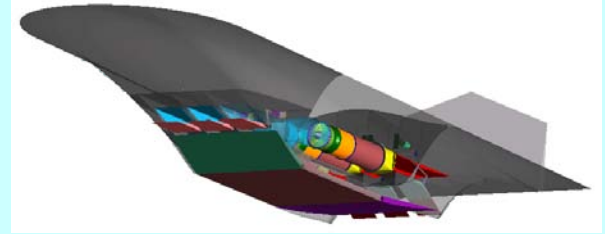

High Mach Turbine Tech Challenges:

- Increase Maximum Mach from 2+ → 4+
- Provide thrust margin over entire range ($0 < M < 4+$)
 - *Light Weight High Temperature Materials*
 - *Thermal Management*
 - *High Temperature Bearings and Seals*
 - *Highly Loaded Turbomachinery*

Scramjet Tech Challenges:

- Reduce Scramjet Ignition Mach Speed ($M5 \rightarrow M3$)
- Provide transition speed margin ($3 < M < 4$)
 - *Advanced Combustion Schemes*
 - *Light Weight High Temperature Materials*
 - *Thermal Management*
 - *High Temperature Seals*

Propulsion System Tech Challenges:

- Propulsion System/ Airframe Integration
- Inlet(s)/ Engine(s)/ Nozzle(s) Integration
- Achieve required performance and operability over entire flight range
- Accomplish stable mode transition

TBCC Discipline Roadmap

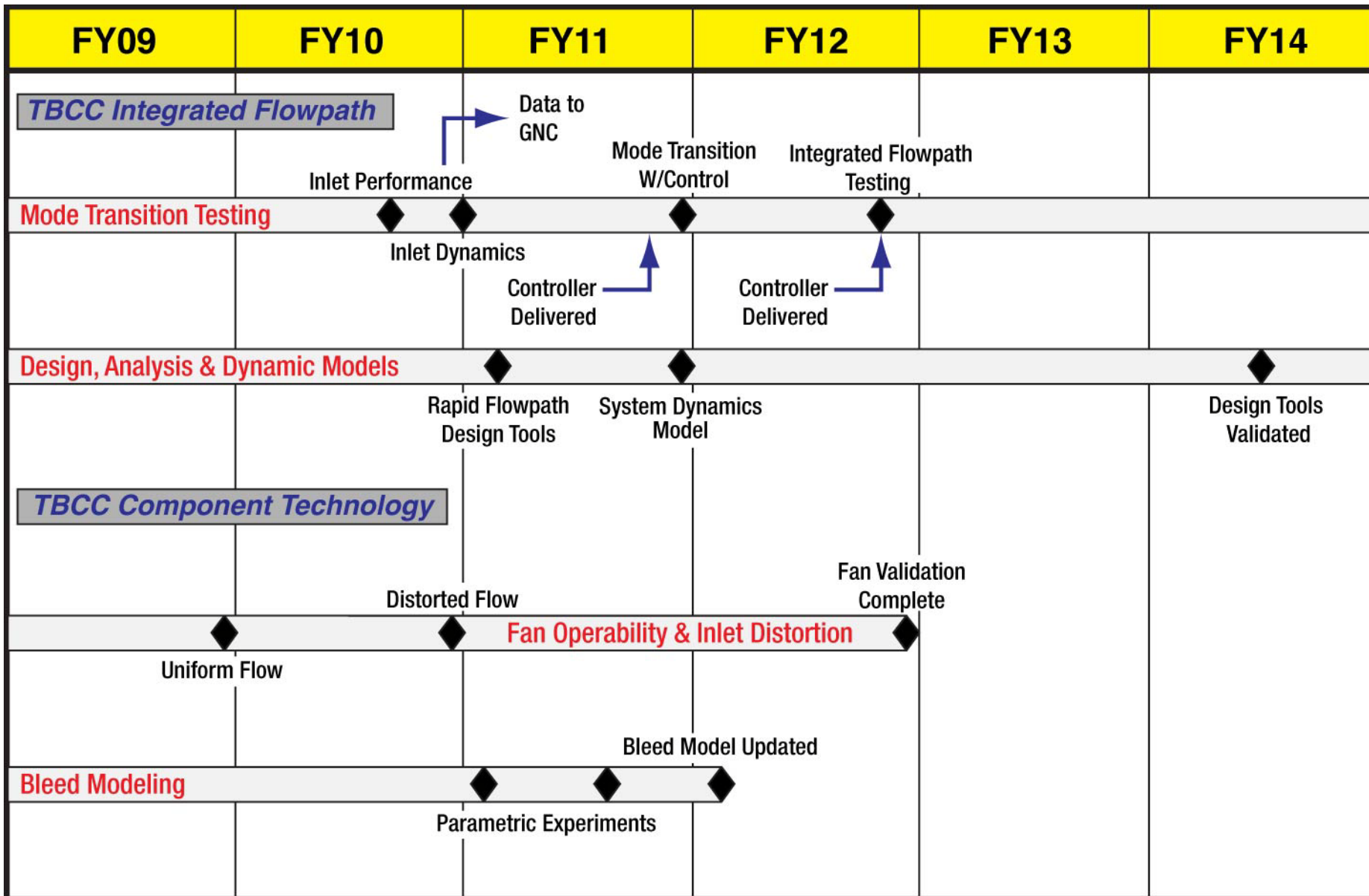

TBCC Technology Approach



Propulsion

M & S

GNC

Supporting Disciplines

Integrated Propulsion System Design & Analysis Tools

Validated tools

MDAO

Partnerships & Collaboration

- AFRL/Aerojet TBCC inlet test
- DARPA/AFRL Facet / MoTr, et al
- RATTLRS - inlet /controls
- AFRL/ WI High Mach Turbine

Ground Experiments

- CCE LIMX Testing in the GRC 10x10 SWT (4 phases)
- High Mach Fan Rig testing in GRC W8 Compressor Facility
- Inlet Bleed Studies in GRC 15X15 cm & 1X1 ft SWT facility

Integrated Flowpath: Computational Efforts

- CCE Low Speed Flowpath
- CCE High Speed Flowpath & Isolator

Component Technologies: Computational Efforts

- High Mach Turbine CFD Analysis
- High Mach Turbine Integrated Inlet/ Fan Analysis

NRA's

- Techland:** Mode Transition Strategies for TBCC inlets
- Boeing:** Flowpath Integration for TBCC Propulsion Systems
- Spiritech:** TBCC Dynamic Simulation Model Development

Challenge: Inlet Performance & Operability

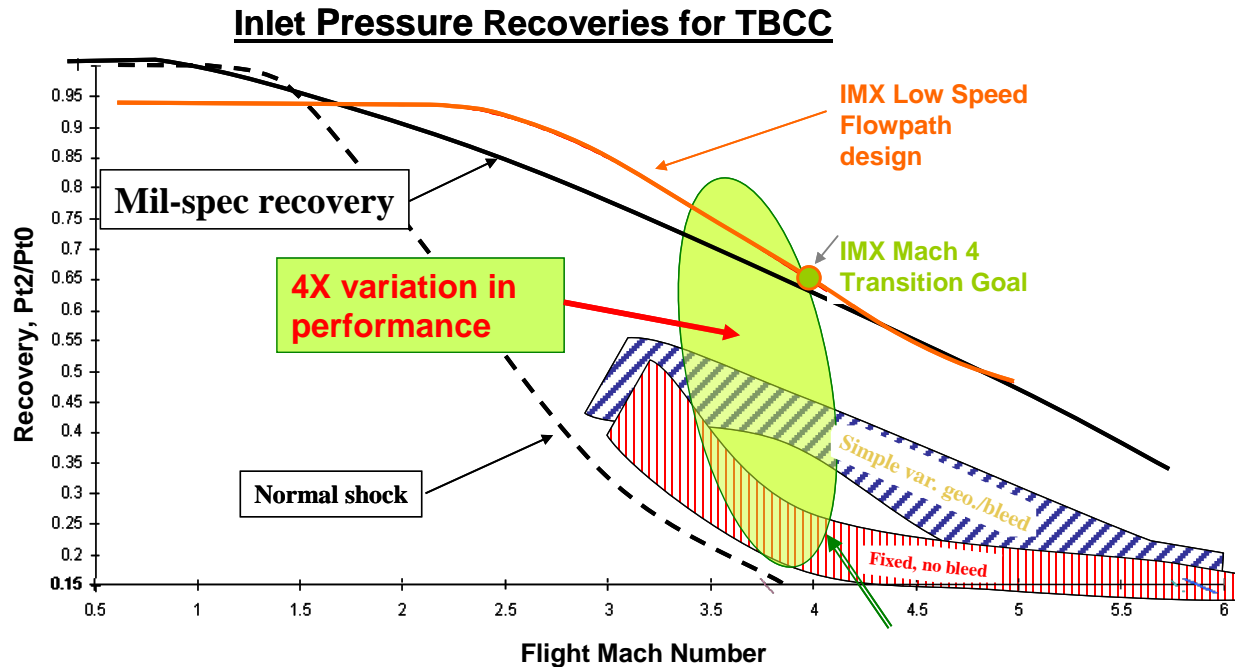

- Establish Inlet performance & Operability over a wide range of conditions
- Validate computational tools for prediction of inlet performance & operability
- Assess the trade-off between bleed and inlet performance/ operability
- Perform predictions of low/high speed inlet interaction
- Evaluate backpressure and cowl positioning effects.

Challenge: Mode Transition



Fully Integrated Inlet / Engine / Vehicle

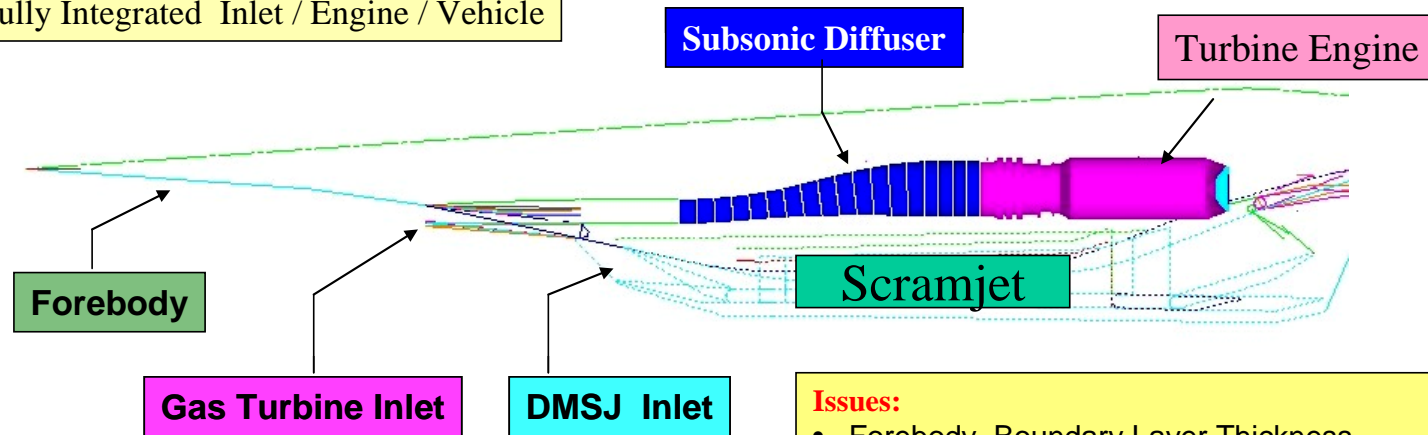

- Issues:**
- Forebody Boundary Layer Thickness
 - Propulsion System Mode Transition
 - Wide Operating Range / Variable Geometry
 - Integration / Interaction Issues
 - inlet / engine compatibility - unstart
 - minimize frontal area/ maximize thrust

- Establish a stable mode transition process
- Perform a controlled mode transition
- Avoid inlet and/or engine unstart
- Mitigate low/high speed inlet/engine interactions.
- Account for backpressure and cowl positioning effects.
- Utilize design tools to optimize the configuration



RESEARCH OBJECTIVES

1. Proof of concept of over/under split flow inlet
 - Develop performance & operability database
 - Demonstrate mode transition
2. Validate CFD predictions for both LSFP and HSFP
3. Develop realistic distortion characteristics throughout the mode transition Mach number range.
4. Testbed for mode transition controls research & for integrated inlet/engine propulsion systems



Test Approach - 4 Phases

1. Inlet performance and operability characterization
2. Unsteady Inlet system Identification for Controls
3. Demonstrate mode transition control strategies and ability to recover from inlet unstart
4. Add engines/ nozzle for integrated system test

CCE Mode Transition Team



Williams International

NASA GRC 10 x 10 Installation

- ✓ Forebody plate
- ✓ Rakes
- ✓ Bleed pipes
- ✓ Bypass Valve Assembly
- ✓ CFD Analyses
- ✓ Test

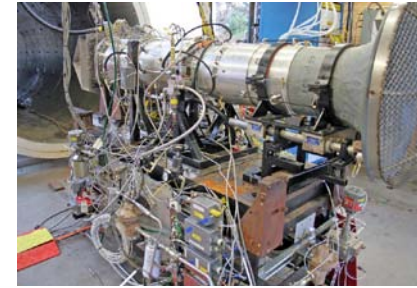

High Mach
Turbine Engine



Integrated Dual Inlet

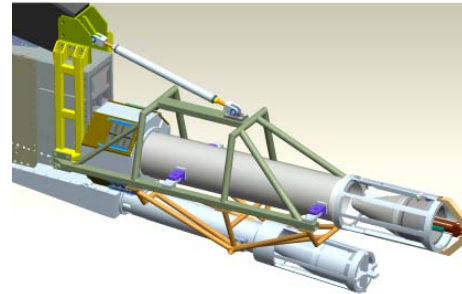

Integration Strongback



Integrated Nozzle

CCE CFD Effort

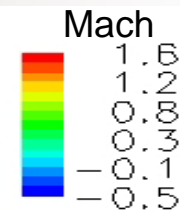
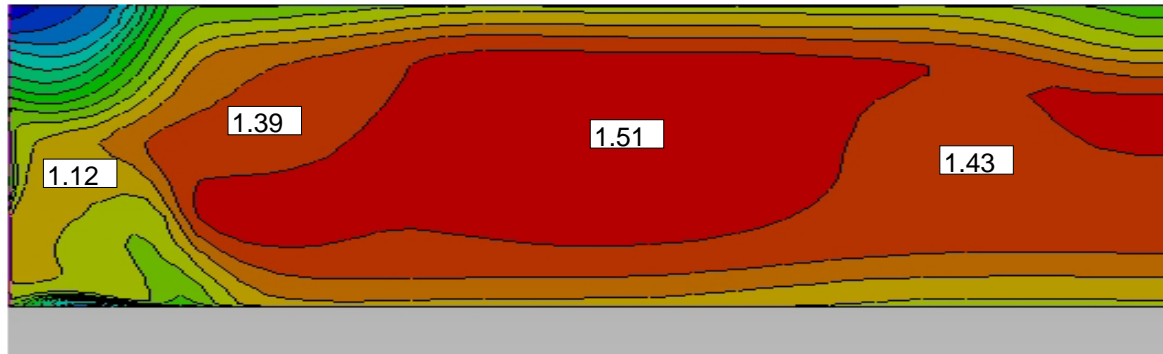

**Mach
Number
Contours
LSFP Inlet
Throat**



IMX-Small-Scale (~1/7th) 1x1 SWT CFD Simulations

- Provided estimates of performance, flowfield visualization, and porous bleed characteristics prior and during the 1x1 SWT testing (Lee, Slater, and Dippold).
- Post-test analysis of 1x1 SWT data to validate Wind-US CFD methods (Slater).
- Post-test analysis of 1x1 SWT data to validate BCFD (Boeing).

IMX-Large-Scale 10x10 SWT CFD Simulations

- Pre-test analysis for performance, characterizing the flowfield, and assessing effectiveness of porous bleed (Boeing).
- Pre-test analysis of the high-speed flowpath and isolator performance (Dippold).
- Explore sensitivities to variations in low-speed ramp angle and back-pressure for development of inlet controls (Slater, Boeing).

Challenge: High Mach Number Turbine Engine which must Operate with Inlet Flow Distortion



Back-pressured CFD Study:
Distortion at M4,
- high bleed
- no v.g.s

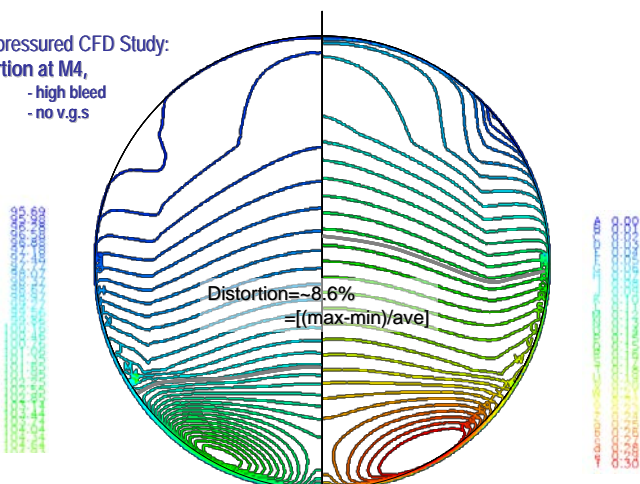

CFD indicates distortion at Turbine Engine Inlet may be high

High Mach Turbine Based propulsion

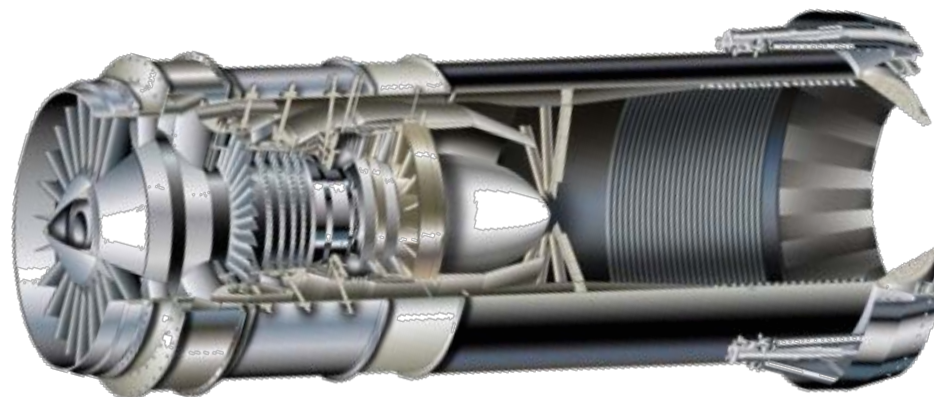

- Characterize Performance & Operability of a High Mach Number Capable Turbine Engine
- Evaluate impact of inlet flow distortion
- Validate the ability of computational tools to predict turbine engine performance & operability and evaluate the impact of inlet flow distortion
- Utilize computational tools to predict inlet /engine interactions.
- Demonstrate Ram Starting of a turbine engine at High Mach conditions.

Williams WJ38 Modifications For Mach 3 Operation & Wind Tunnel Integrated Inlet Test



- **Expanded operational envelope to accommodate**
 - SLS development tests
 - Ability to run a range of dynamic pressures from ~ 570 – 1500 psf Q
 - Up to 3.1 Mach number (Base engine Mach 0.9)
- **Increase T2 temperature capability (fan stage, housing, bearings, rub strips)**
 - New distortion tolerant fan stage, bypass duct, liners, high specific flow fan and IGV
 - All new hardware downstream of turbine (AB design from IR&D program)
- **SLS testing At WI w/ Integrated CCE Nozzle**
- **TBCC integrated inlet / engine Test**
 - WI to support facility and fuel system set up
 - WI to provide on-site test support
 - Control system software verification
 - TBCC interface (turbine/ramjet) issue validation
- **Engine delivery 1st Quarter FY10**

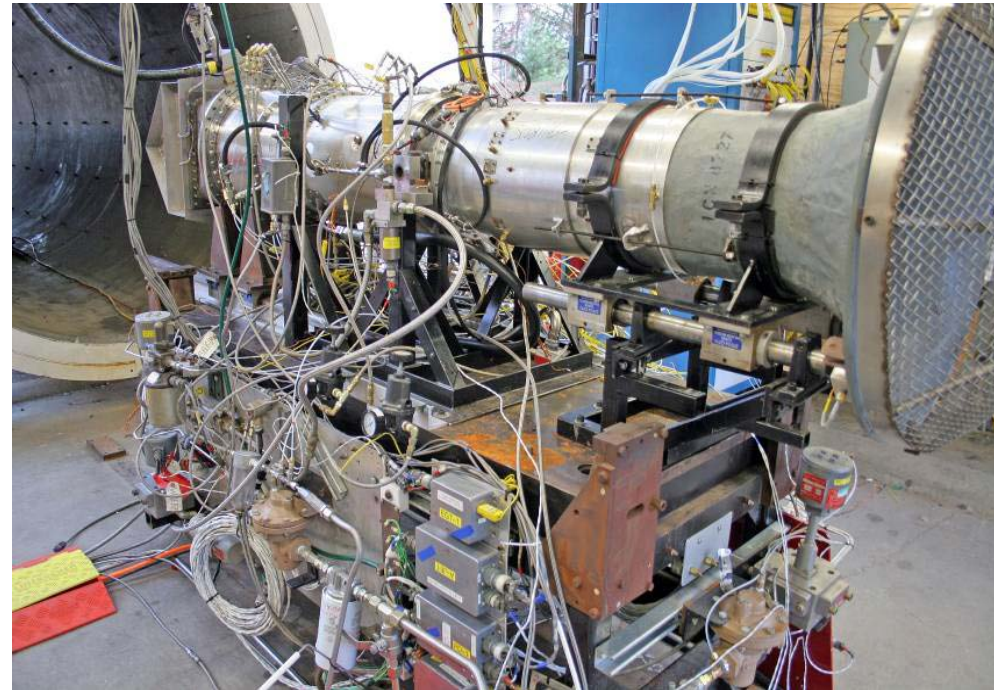

TBCC Fan Stage Operability and Performance



Fan Rotor Blisk



Inlet Distortion Screens

RTA: GE 57 / NASA Mach 4 capable TBCC Engine

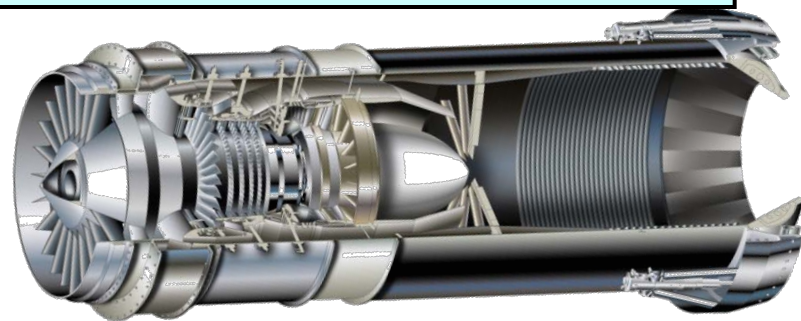

FAN STAGE = Rotor + OGV + Fan Frame Strut

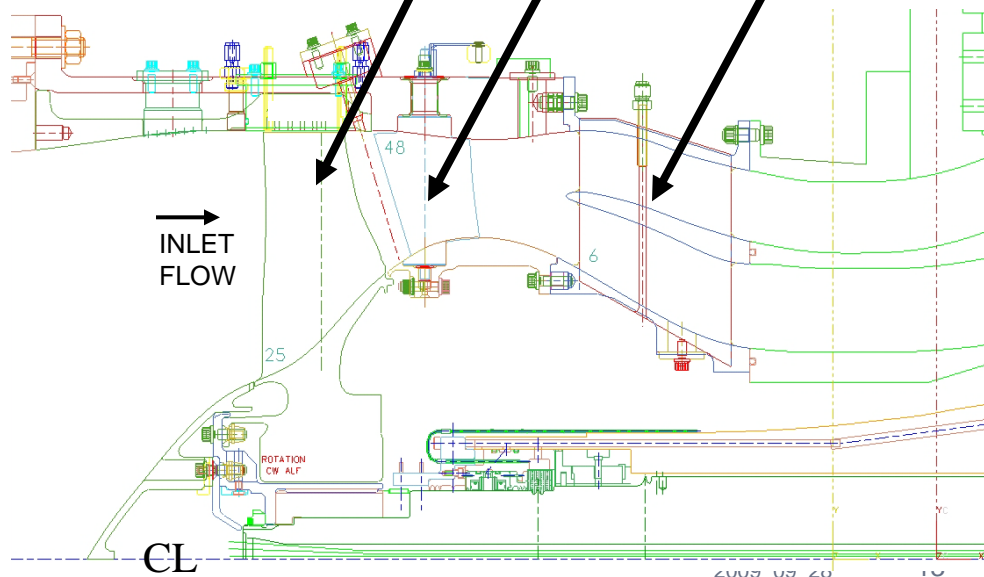

Approach:

- Perform sub-scale testing of a relevant Mach 4 turbine engine fan stage in the NASA W8 high speed compressor facility.
- Predict performance & operability prior to test using SOA analysis tools.
- Map fan stage performance and measure stall line stability boundary over wide range of engine operation and compare to pre-test predictions.
- Measure Fan Aeromechanics and identify vibration & flutter boundaries
- Assess ability of SOA tools to predict flutter.
- Incorporate inlet distortions and quantify performance & operability
- Assess the capability of SOA tools to predict results with flow distortions
- Utilize test article to understand physics and improve models.

TURBO CODE DEVELOPMENT



Objective:

1. Develop high fidelity CFD tools capable of predicting unsteady 3D, full annulus or phase lag, multi-stage turbomachinery in integrated inlet/fan configurations with multiple exit flow paths.
2. Validate CFD results with aero and aeromechanical data taken from the RTA fan rig tests.

Technical Approach:

1. Expand TURBO (MPI-implemented multi-block parallel, 3D unsteady, multi-stage, full annulus or phase lag mode) to handle a wider spectrum of turbomachinery configurations.
2. Establish the speed line at 80% design with both phase lag and full annulus simulations.
3. Predict aeromechanical response due to flow distortions and flutter.
4. Validate results with the fan rig test data.

Major Accomplishments to date:

- Split flow path and stator-Strut interface features have been implemented in TURBO and debugged.
- Phase lag and full annulus computation of the RTA fan at 80% speed with uniform inlet condition close to the operating point are near completion.
- The figure shows total pressure contour (relative scales) results from the full annulus simulation (218 blocks with 45 million cells) at 2 axial locations with the casing and some of the blades being removed for clarity.

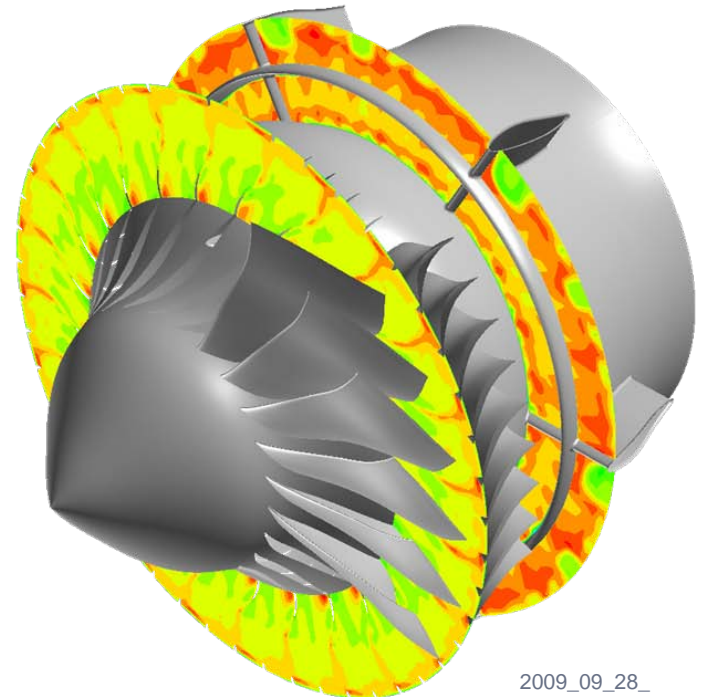

Bleed Modeling



Elements of Model:

- Critical aspect in CFD simulation of the low-speed flowpath.
- Capability to predict bleed rates and plenum pressures.
- Captures the spatial variation of the bleed rates over the bleed region due to pressure variations & terminal shock location
- Simulate either constant-pressure or fixed-exit bleed plenums.
- CFD simulations will explore the role of bleed and the need for control of bleed during inlet mode transition.

Computational Efforts:

- Wind-US CFD analysis (Slater)
- BCFD analysis (Boeing NRA)
- PEPSI-S PNS Solver (Benson, et al)

Experimental Efforts:

- Test in GRC 15X15 cm facility FY11
- IMX entry with variable bleed in GRC 1X1 ft SWT FY11
- CCE LIMX testing in FY10

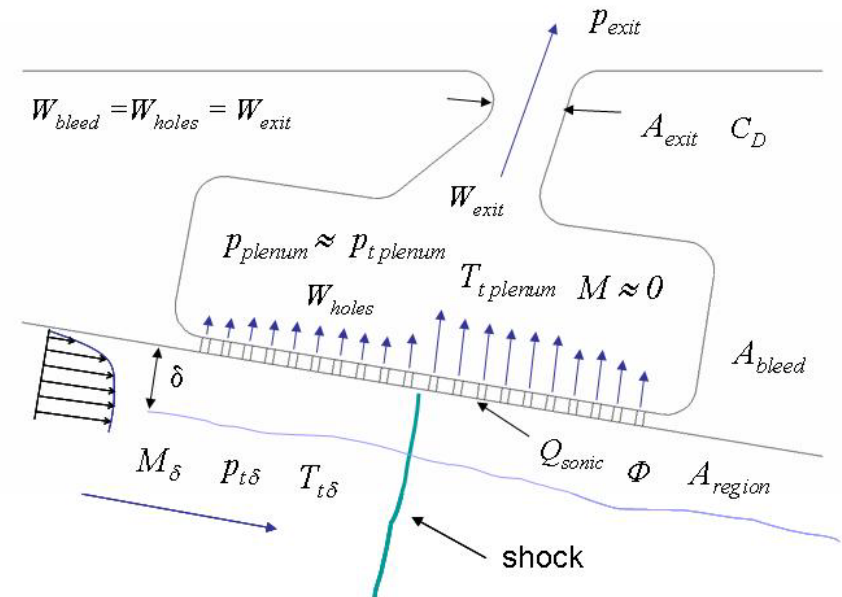
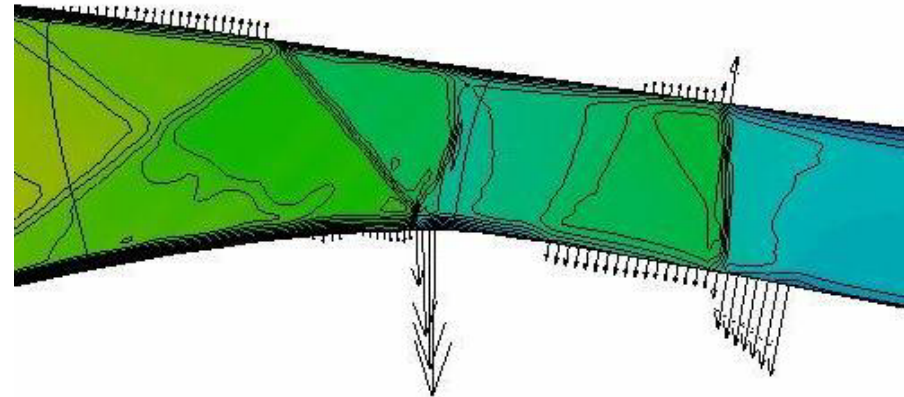

TBCC: NRA Integration Strategy



**Dynamic System
Modeling Tools & MDO
Process Tools**

**Large Scale TBCC Mode
Transition Database:
Performance & Operability**

NRA

Multidisciplinary Optimization (MDO) of an Integrated Flowpath
Dynamic simulation model for gas turbine engine
Dynamic simulation model for dual mode ramjet
Dynamic simulation model for thermal management system
Dynamic simulation model for hydraulic system

NASA

Interactive PNS Solver for Inlet/ Nozzle Preliminary Design
Rapid Geometry and Mesh Generation

Analysis & Design Tools

NRA

Optimized Bleed for Performance and Operability of TBCC Inlets
Mode Transition Strategies for TBCC Inlets
CFD Analysis to generate TBCC Database for Performance and Control System Development
Test Requirements Document for TBCC Mode Transition Experiment
Assessment of inlet performance characterization and mode transition results

NASA

Flowpath Bleed Modeling
TBCC Inlet and Engine mode transition experiments
Controls Development

TBCC Database

NRA TechLand: Mode Transitioning for Dual-Flow TBCC Propulsion

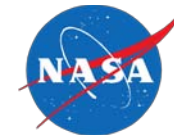

Objectives:

- Investigate TBCC dual inlet designs both analytically and experimentally
- Provide unique expertise and support in the development and testing of the NASA CCE mode transition experiments including flow path integration, incorporation of control strategies, and engine integration.

Task Elements

- Develop inlet mode transition strategies
- Provide dual inlet operability database and identify optimum bleed configurations
- Support testing on-site & provide consultation on inlet/ engine integration and test procedures

Accomplishments:

- Documented scheduled mode transition strategy and optimum bleed configurations
- Developed prioritized test matrix and instrumentation plan and computing requirements in coordination w/ NASA participation

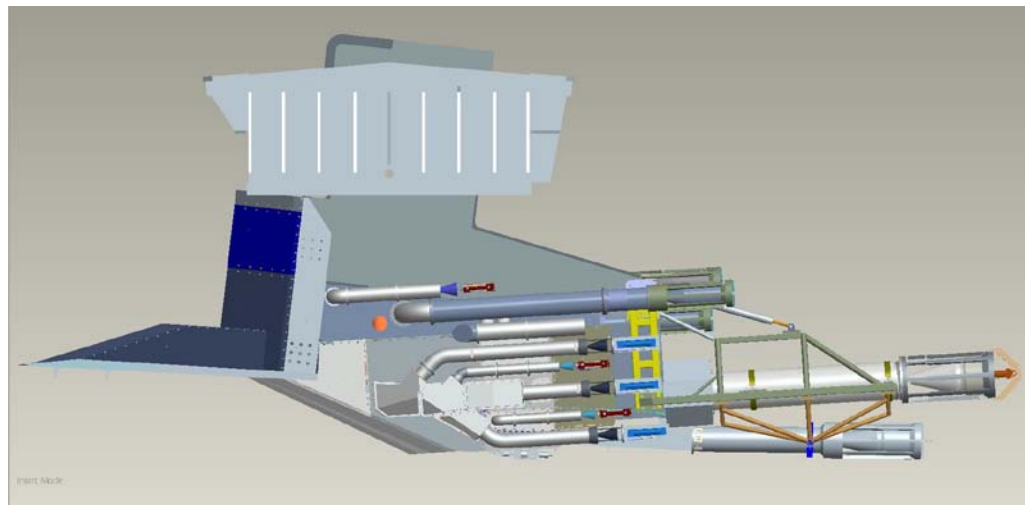

FY 2008-10 Key Deliverables and Milestones:

FY'08 3rd qtr.— report documented data and analysis of small-scale dual inlet performance and operability

FY'09 3rd qtr. – LIMX test requirements document

FY'10 4th qtr. – Preliminary report on inlet performance characterization and mode transition results.

NRA Boeing: Flowpath Integration for TBCC Propulsion Systems



Objectives:

- Validate CFD tools and methods applied to a TBCC flowpath
- Develop a turbine-based low-speed propulsion baseline design for a NASA TBCC vehicle
- Develop and apply a multi-disciplinary analysis & optimization (MDAO) process to a NASA TBCC design

Task Elements:

- Perform high fidelity “rapid” CFD analysis to generate a performance data base for the NASA LIMX model test in the GRC 10X10
- Develop an integrated low-speed propulsion system baseline design for the TBCC 1st stage flowpath of the NASA TSTO HRRLS vehicle
- Conduct MDAO of the integrated TBCC 1st stage flowpath for the NASA TSTO HRRLS vehicle

Accomplishments :

- TBCC propulsion flowpath performance data base for LIMX which includes back-pressured low-speed and high-speed flowpath cases
- CFD-generated control loads database for small perturbations in back pressure and cowl flap angle of the LIMX low-speed propulsion flowpath

Centerline Mach Contours for LIMX at Mach 3.5

(No Back Pressure Test Case)

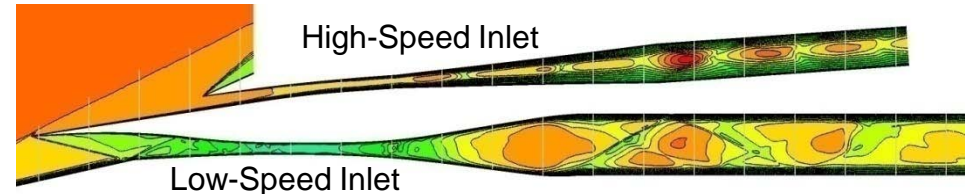

Scheduled Key Milestones:

- April 30, 2008: CFD Analysis and Validation Plan
- September 30, 2008: LIMX Flowpath Performance Database
- June 1, 2009: LIMX Control Loads Database and Analysis Report
- Jan. 30, 2010: RALV TBCC 1st Stage Lo-Speed Propulsion System Baseline Design and Performance
- Sept. 1, 2010: Recommended MDAO Design Process Report
- Sept. 1, 2010: TBCC Flowpath Design and Performance Report

NRA SPIRITECH: Turbine-Based Combined Cycle Dynamic Simulation Model Development Program



Objectives:

Develop tools and procedures that lead to numerical dynamic system modeling tools for TBCC System, and demonstrate mode transition using those tools in an integrated model

Task 1 & 2: Develop dynamic simulation model for gas turbine & DMSJ engines

Task 3: Develop dynamic simulation model for Thermal Management System

Task 4: Develop dynamic simulation model for Hydraulic/Kinematic System

Technical Approach:

Develop an integrated simulation tool (Simulink):

- ✓ Gas turbine engine (2008)
- ✓ Dual-mode scramjet (2008)
- Thermal management system (2009)
- Hydraulic system (2009)

Accomplishments to Date:

Task 1 & 2: Complete

Task 2: Hydraulic/Kinematic dynamic model is in progress

- ✓ Inlet/Nozzle kinematic models complete
- Pressure loads in progress

Task 2: Thermal management model is in progress

- ✓ Fuel/power subsystems complete
- Delivery subsystem in progress

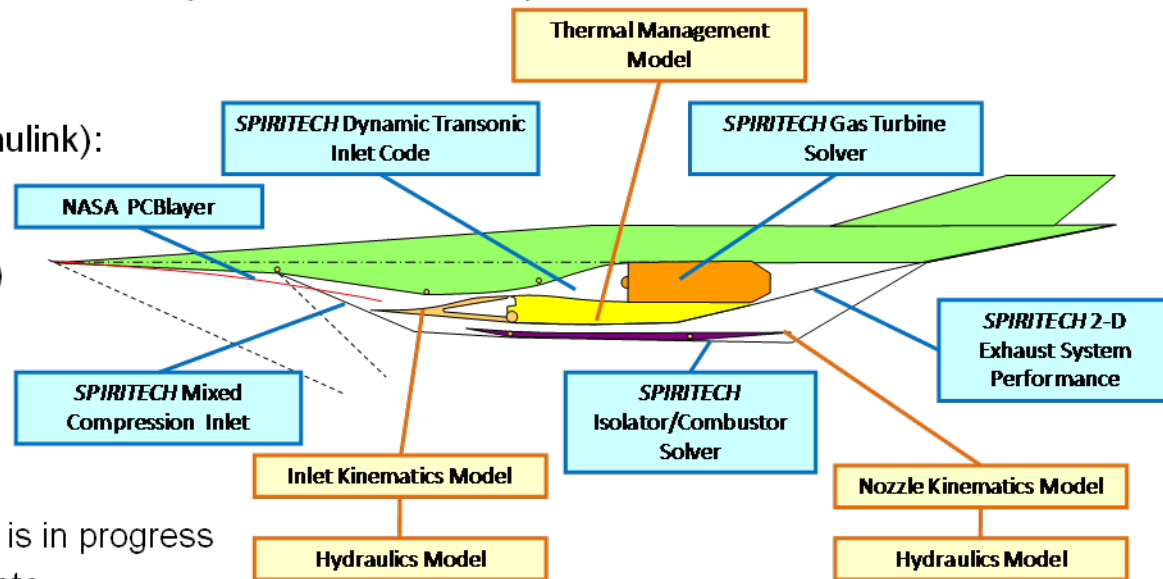

Aerojet Combined Cycle Integrated Inlet Test, Transonic Test Entry



AEROJET

• *What*

Transonic Wind Tunnel Test for the Aerojet
Advanced Combined Cycle Integrated Inlet, (ACCII)

- Previous test showed workable pressure recovery and distortion levels



• *Why*

- To extend previous wind tunnel performance and operation data over the full operating regime
- To increase in-house understanding of integrated combined-cycle technology
- To identify potential technology challenges related to integrated combined-cycle configurations
- Important technology development for future Operationally Responsive Space Access platforms

• *Current Status*

- AFRL/RBAA led program with RZ support (RZA and RZT) in partnership with the NASA Fundamental Aeronautics Program, Hypersonics project (GRC)
- Modified existing model
 - Re-instrumented existing model and modify model mount to integrate with 8 x 6 foot facility at NASA Glenn Research Center (NASA GRC)
 - Added vacuum lines to simulate demand from turbojet engines and simulate active pilot to create thrust and prevent flow recirculation in dual-mode ramjet
- Testing completed in September, 2009. Preliminary Results are under review.
- *First complete data set (from subsonic through propulsion mode transition) for an integrated TBCC inlet.*



SUMMARY: TBCC Discipline **FY10 Key Deliverables and Milestones**



- **FY09/ 1st qtr. – High Mach Turbine Fan CFD compared with Experimental Data for uniform inflow**
- **1st qtr. – CCE Inlet Model & Strongback delivered to GRC**
- **1st / 2nd qtr. – Mach 3 Turbine Engines Delivered**
- **2nd qtr. – CCE Inlet Model installed into the NASA GRC 10X10 SWT**
- **3rd qtr. – Steady State Large Scale Inlet Test complete**
- **4th qtr. – Large Scale Inlet Dynamics test complete**
- **4th qtr. – High Mach Fan Rig test with flow distortion (as characterized during CCE Steady State Testing) conducted in GRC W8 facility**

Hypersonics Airbreathing Propulsion Session

Turbine Based Combined Cycle Discipline



Agenda

➤ **Overview of the Turbine Based Combined Cycle Discipline**

Scott Thomas

➤ **Status of the Combined Cycle Engine Rig**

Dave Saunders

➤ **High Mach Number Turbine Fan Development**

Ken Suder