

## Tool for Coupling a Torque Wrench to a Round Cable Connector

**Torque is applied without offset.**

*Lyndon B. Johnson Space Center, Houston, Texas*

A tool makes it possible to couple a torque wrench to an externally knurled, internally threaded, round cable connector. The purpose served by the tool is to facilitate the tightening of multiple such connectors (or the repeated tightening of the same connector) to repeatable torques.

The design of a prior cable-connector/torque-wrench coupling tool provided for application of the torque-wrench jaws to a location laterally offset from the axis of rotation of the cable connector, making it necessary to correct the torque reading for the offset. Unlike the design of the prior tool, the design of the present tool provides for application of the torque-wrench jaws to a location on the axis of rotation, obviating correction of the torque reading for offset.

The present tool (see figure) consists of a split collet containing a slot that provides clearance for inserting and bending the cable, a collet-

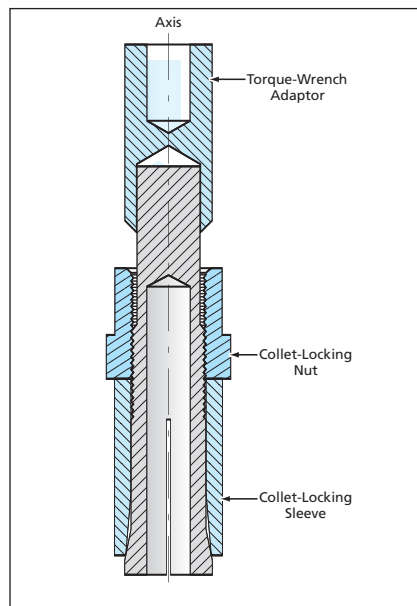

This **Simple Tool** makes it possible to tighten round cable connectors to repeatable torques, without need to make offset corrections.

locking sleeve, a collet-locking nut, and a torque-wrench adaptor that is press-fit onto the collet. Once the collet is positioned on the cable connector, the collet-locking nut is turned to force the collet-locking sleeve over the collet, compressing the collet through engagement of tapered surfaces on the outside of the collet and the inside of the locking sleeve. Because the collet is split and therefore somewhat flexible, this compression forces the collet inward to grip the connector securely. The torque wrench is then applied to the torque-wrench adaptor in the usual manner for torquing a nut or a bolt.

*This was done by Scott C. Hacker, Richard J. Dean, and Scott W. Burge of Johnson Space Center. For further information, contact Johnson Technology Transfer Office at (281) 483-3809.*