

to test this method (see Fig. 1), the local oscillator has a wavelength of 1,064 nm, and another laser is used as a signal transmitter at a slightly different wavelength to establish an IF of about 6 MHz. There are 16 photodetectors in a 4x4 focal-plane array; the detector outputs are digitized at a sampling rate of 25 MHz, and the signals in digital form are combined by use of the LMS algorithm. Convergence of the adaptive combining algorithm in the presence of

simulated atmospheric turbulence for optical PPM signals has already been demonstrated in the laboratory; the combined output is shown in Fig. 2(a), and Fig. 2(b) shows the behavior of the phase of the combining weights as a function of time (or samples). We observe that the phase of the weights has a sawtooth shape due to the continuously changing phase in the down-converted output, which is not exactly at zero frequency.

Detailed performance analysis of this coherent free-space optical communication system in the presence of simulated atmospheric turbulence is currently under way.

*This work was done by Victor Vilnrotter and Michela Muñoz Fernández of Caltech for NASA's Jet Propulsion Laboratory. Further information is contained in a TSP (see page 1).  
NPO-40974*

## Multichannel Phase and Power Detector

Purposes served by this system include beam steering and power combining.

NASA's Jet Propulsion Laboratory, Pasadena, California

An electronic signal-processing system determines the phases of input signals arriving in multiple channels, relative to the phase of a reference signal with which the input signals are known to be coherent in both phase and frequency. The system also gives an estimate of the power levels of the input signals. A prototype of the system has four input channels that handle signals at a frequency of  $\approx 9.5$  MHz, but the basic principles of design and operation are extensible to other signal frequencies and greater numbers of channels.

The prototype system consists mostly of three parts:

- An analog-to-digital-converter (ADC) board, which coherently digitizes the input signals in synchronism with the reference signal and performs some simple processing;
- A digital signal processor (DSP) in the form of a field-programmable gate

array (FPGA) board, which performs most of the phase- and power-measurement computations on the digital samples generated by the ADC board; and

- A carrier board, which allows a personal computer to retrieve the phase and power data.

The DSP contains four independent phase-only tracking loops, each of which tracks the phase of one of the pre-processed input signals relative to that of the reference signal (see figure). The phase values computed by these loops are averaged over intervals, the length of which is chosen to obtain output from the DSP at a desired rate. In addition, a simple sum of squares is computed for each channel as an estimate of the power of the signal in that channel.

The relative phases and the power level estimates computed by the DSP could be used for diverse purposes in

different settings. For example, if the input signals come from different elements of a phased-array antenna, the phases could be used as indications of the direction of arrival of a received signal and/or as feedback for electronic or mechanical beam steering. The power levels could be used as feedback for automatic gain control in preprocessing of incoming signals. For another example, the system could be used to measure the phases and power levels of outputs of multiple power amplifiers to enable adjustment of the amplifiers for optimal power combining.

*This work was done by Samuel Li, James Lux, Robert McMaster, and Amy Boas of Caltech for NASA's Jet Propulsion Laboratory. Further information is contained in a TSP (see page 1).  
NPO-42697*

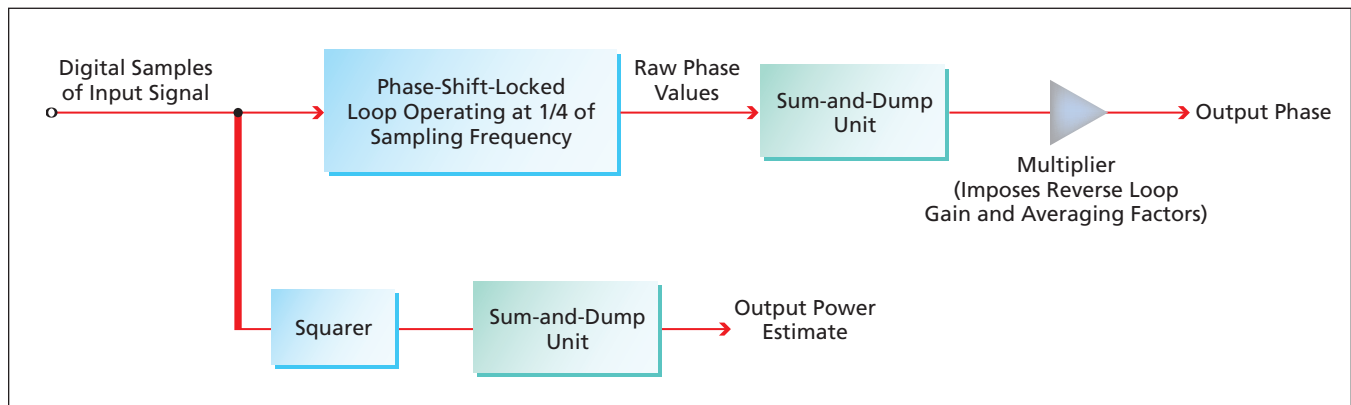

A Functional Block Diagram of the DSP shows one channel. The other channels are identical.