

This **Laboratory Setup** was used to demonstrate the basic principle of generating a microwave signal in a low-threshold hyperparametric process.

of the combiner was fed to a fast photodiode that demodulated light and generated microwave signal.

In this optical configuration, the resonator was incorporated into one arm of a Mach-Zehnder interferometer, which was necessary for the following reasons: It was found that when the output of the resonator was sent directly to a fast photodiode, the output of the photodiode

did not include a measurable microwave signal. However, when the resonator was placed in an arm of the interferometer and the delay in the other arm was set at the correct value, the microwave signal appeared. Such behavior is distinctly characteristic of phase-modulated light.

The phase-modulation signal had a frequency of about 8 GHz, corresponding to the free spectral range of the resonator.

The spectral width of this microwave signal was less than 200 Hz. The threshold pump power for generating the microwave signal was about 1 mW. It would be possible to reduce the threshold power by several orders of magnitude if resonators could be made from crystalline materials in dimensions comparable to those of microresonators heretofore made from fused silica.

This work was done by Lute Maleki, Andrey Matsko, Anatoliy Savchenkov, and Dmitry Strekalov of Caltech for NASA's Jet Propulsion Laboratory. Further information is contained in a TSP (see page 1).

In accordance with Public Law 96-517, the contractor has elected to retain title to this invention. Inquiries concerning rights for its commercial use should be addressed to:

*Innovative Technology Assets Management
JPL*

*Mail Stop 202-233
4800 Oak Grove Drive
Pasadena, CA 91109-8099
(818) 354-2240*

E-mail: iaoffice@jpl.nasa.gov

Refer to NPO-41074, volume and number of this NASA Tech Briefs issue, and the page number.

Pointing Reference Scheme for Free-Space Optical Communications Systems

A technique is proposed for referencing infrared transmit lasers with silicon detectors.

NASA's Jet Propulsion Laboratory, Pasadena, California

A scheme is proposed for referencing the propagation direction of the transmit laser signal in pointing a free-space optical communications terminal. This recently developed scheme enables the use of low-cost, commercial silicon-based sensors for tracking the direction of the transmit laser, regardless of the transmit wavelength. Compared with previous methods, the scheme offers some advantages of less mechanical and optical complexity and avoids

expensive and exotic sensor technologies.

In free-space optical communications, the transmit beam must be accurately pointed toward the receiver in order to maintain the communication link. The current approaches to achieve this function call for part of the transmit beam to be split off and projected onto an optical sensor used to infer the pointed direction. This requires that the optical sensor be sensitive to the wavelength of the transmit

laser. If a different transmit wavelength is desired, for example to obtain a source capable of higher data rates, this can become quite impractical because of the unavailability or inefficiency of sensors at these wavelengths. The innovation proposed here decouples this requirement by allowing any transmit wavelength to be used with any sensor.

We have applied this idea to a particular system that transmits at the standard

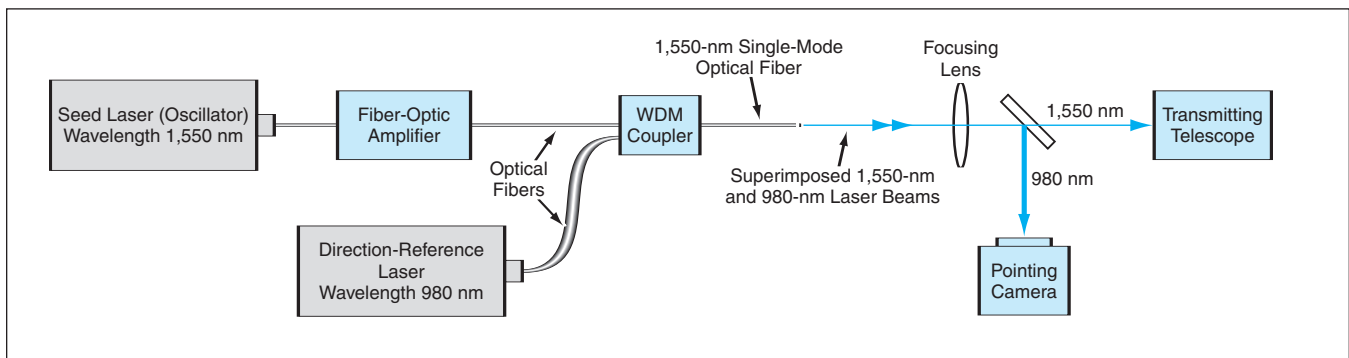

An **Example Implementation** is shown of the much simpler pointing reference scheme.

telecommunication wavelength of 1,550 nm and uses a silicon-based sensor, sensitive from 0.5 to 1.0 micrometers, to determine the pointing direction. The scheme shown in the figure involves integrating a low-power 980-nm reference or boresight laser beam coupled to the 1,550-nm transmit beam via a wavelength-division-multiplexed fiber coupler. Both of these signals propagate through the optical fiber where they achieve an extremely high level of co-alignment before they are launched into the telescope. The telescope uses a dichroic beam splitter to reflect the 980-nm beam onto the silicon image sensor (a quad detector, charge-coupled device, or active-pixel-sensor array) while the 1,550-nm signal beam is transmitted through the optical assembly toward the remotely located receiver. Since the 980-nm reference signal originates from the same single-mode fiber-coupled source as the transmit signal, its position on the sensor is used to

accurately determine the propagation direction of the transmit signal.

The optics are considerably simpler in the proposed scheme due to the use of a single aperture for transmitting and receiving. Moreover, the issue of mechanical misalignment does not arise because the reference signal and transmitted laser beams are inherently co-aligned. The beam quality of the 980-nm reference signal used for tracking is required to be circularly symmetric and stable at the tracking-plane sensor array in order to minimize error in the centroiding algorithm of the pointing system. However, since the transmit signal is delivered through a fiber that supports a single mode at 1,550 nm, propagation of higher order 980-nm modes is possible. Preliminary analysis shows that the overall mode profile is dominated by the fundamental mode, giving a near symmetric profile. The instability of the mode was

also measured and found to be negligible in comparison to the other error contributions in the centroid position on the sensor array.

This work was done by Malcolm Wright, Gerardo Ortiz, and Muthu Jeganathan of Caltech for NASA's Jet Propulsion Laboratory. Further information is contained in a TSP (see page 1).

In accordance with Public Law 96-517, the contractor has elected to retain title to this invention. Inquiries concerning rights for its commercial use should be addressed to:

*Innovative Technology Assets Management
JPL
Mail Stop 202-233
4800 Oak Grove Drive
Pasadena, CA 91109-8099
(818) 354-2240
E-mail: iaoffice@jpl.nasa.gov
Refer to NPO-30606, volume and number of this NASA Tech Briefs issue, and the page number.*

High-Level Performance Modeling of SAR Systems

NASA's Jet Propulsion Laboratory, Pasadena, California

SAUSAGE (Still Another Utility for SAR Analysis that's General and Extensible) is a computer program for modeling (see figure) the performance of syn-

thetic-aperture radar (SAR) or interferometric synthetic-aperture radar (InSAR or IFSAR) systems. The user is assumed to be familiar with the basic principles of

SAR imaging and interferometry. Given design parameters (e.g., altitude, power, and bandwidth) that characterize a radar system, the software predicts various performance metrics (e.g., signal-to-noise ratio and resolution). SAUSAGE is intended to be a general software tool for quick, high-level evaluation of radar designs; it is not meant to capture all the subtleties, nuances, and particulars of specific systems. SAUSAGE was written to facilitate the exploration of engineering tradeoffs within the multidimensional space of design parameters. Typically, this space is examined through an iterative process of adjusting the values of the design parameters and examining the effects of the adjustments on the overall performance of the system at each iteration. The software is designed to be modular and extensible to enable consideration of a variety of operating modes and antenna beam patterns, including, for example, strip-map and spotlight SAR acquisitions, polarimetry, burst modes, and squinted geometries.

This program was written by Curtis Chen of Caltech for NASA's Jet Propulsion Laboratory. Further information is contained in a TSP (see page 1).

This software is available for commercial licensing. Please contact Karina Edmonds of the California Institute of Technology at (626) 395-2322. Refer to NPO-43373.

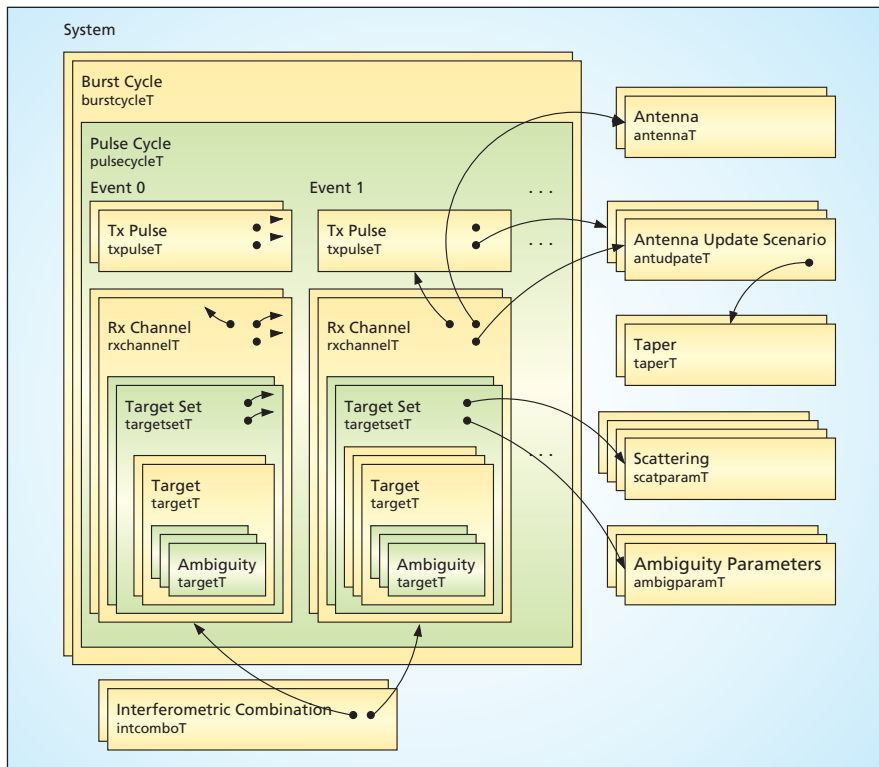

Logical Block Diagram shows how a radar system is modeled by SAUSAGE. Blocks represent software objects, which describe physical aspects of the system. Arrays are indicated by stacked blocks. Arrows represent pointers to other objects.