

Robust IR Remote sensing technique of the total column of trace gases including carbon dioxide and methane

Georgieva, E.M¹, Heaps, W.S.²

¹Joint Center for Earth Systems Technology (JCET), UMBC, Baltimore, MD 21228, USA

e-mail: Elena.M.Georgieva@nasa.gov

² NASA, Goddard Space flight Center, Greenbelt, MD 20771, USA

Progress on the development of a differential radiometer based upon the Fabry-Perot interferometer (FPI) for methane (CH₄) and carbon dioxide (CO₂) detection in the atmosphere is presented. Methane measurements are becoming increasingly important as a component of NASA's programs to understand the global carbon cycle and quantify the threat of global warming. Methane is the third most important greenhouse gas in the Earth's radiation budget (after water vapor and carbon dioxide) and the second most important anthropogenic contributor to global warming. The importance of global warming and air quality to society caused the National Research Council to recommend that NASA develop the following missions [1]: ASCENDS (Active Sensing of CO₂ Emissions over Nights, Days, and Seasons), GEOCAPE (Geostationary Coastal and Air Pollution Events), and GACM (Global Atmosphere Composition Mission). Though methane measurements are not specifically called out in these missions, ongoing environmental changes have raised the importance of understanding the methane budget. In the decadal survey is stated that "to close the carbon budget, we would also address methane, but the required technology is not obvious at this time. If appropriate and cost-effective methane technology becomes available, we strongly recommend adding a methane capability". In its 2007 report the International Panel on Climate Change identified methane as a key uncertainty in our understanding saying that the causes of recent changes in the growth rate of atmospheric CH₄ are not well understood. What we do know is that methane arises from a number of natural sources including wet lands and the oceans plus man made sources from agriculture, as well as coal and petroleum production and distribution. It has recently been pointed out that large amount of methane are frozen in the permafrost of Canada and Siberia. There is a fear that melting of this permafrost driven by global warming may release large amounts of methane very suddenly further exacerbating climate change [2].

Last year our group began a joint effort with Johns Hopkins Applied Physics Laboratory to investigate the possibility of developing a small unmanned aerial vehicle (UAV) equipped to measure greenhouse gases-particularly methane. Although we are targeting our system for smaller UAV's the instrument will be directly applicable to missions involving larger NASA UAV's such as Global Hawk or even on missions utilizing manned aircraft. Because of its small size, inherent ruggedness and simplicity some version of our proposed instrument may find a role as a satellite instrument for NASA or NOAA.

Figure 1 shows the existing methane sensor developed using IRAD and Ignition funds [3]. Light enters the instrument from the left, passes through a bandpass filter and is then split. One half goes directly to a detector and the other half passes through a Fabry-Perot interferometer tuned to transmit at wavelengths where methane absorbs light. The detector for this half then responds strongly to changes in the atmospheric methane. The sensor is using ~1600 nm light and has the capability of measuring CH₄ in the Earth environment. We are working now on an improved methane sensor which is using a CCD array to sample both the reference and the Fabry-Perot signal simultaneously on different areas of the array. It

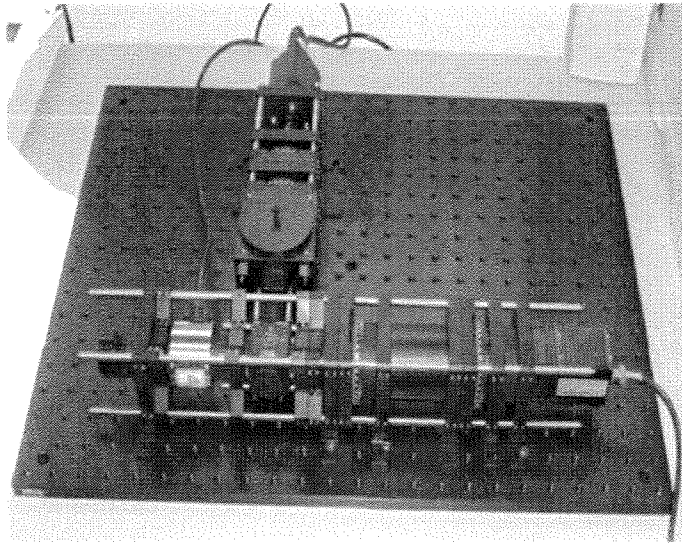

will increase the signal to noise ratio (SNR) while permitting a reduction in the overall size of the instrument. (**Figure 2**)

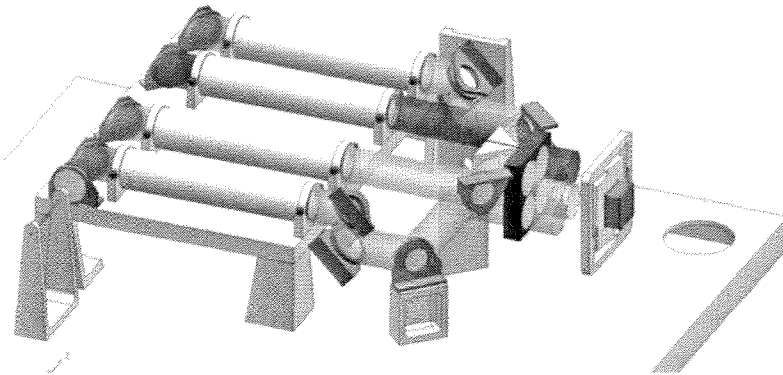

Limited testing demonstrates that our Fabry-Perot based differential radiometer has the ability to measure the methane column both as a ground based instrument as well as from an airborne platform. Further work to improve the light gathering properties of the instrument front end

and tuning of the Fabry-Perot bandpass should increase the sensitivity and response time.

References:

- [1] NRC, Earth Science and Applications from Space: National Imperatives for the Next Decade and Beyond, *The National Academies Press. Committee on Earth Science and Applications from Space: A Community Assessment and Strategy for the Future Space Studies Board*, www.nap.edu, 2007.
- [2] K. W. Anthony, "Methane: A Menace Surfaces", *Scientific American*, Dec., pp. 68-75, 2009.
- [3] W.S. Heaps, E.L. Wilson, E. M. Georgieva, "Precision Measurement of Atmospheric Trace Constituents Using a Compact Fabry-Perot Radiometer", *International Journal of High Speed Electronics and Systems*, vol.18, Sept., 2008.

Robust IR Remote sensing technique of the total column of trace gases including carbon dioxide and methane

Georgieva, E.M.¹, Heaps, W.S.²

¹Joint Center for Earth Systems Technology (JCET), UMBC, Baltimore, MD 21228, USA

e-mail: Elena.M.Georgieva@nasa.gov

²NASA, Goddard Space flight Center, Greenbelt, MD 20771, USA

Abstract Progress on the development of a differential radiometer based upon the Fabry-Perot interferometer (FPI) for methane (CH₄) and carbon dioxide (CO₂) detection in the atmosphere is presented. Carbon dioxide and methane measurements are becoming increasingly important as a component of NASA's programs to understand the global carbon cycle and quantify the threat of global warming. Methane is the third most important greenhouse gas in the Earth's radiation budget (after water vapor and carbon dioxide) and the second most important anthropogenic contributor to global warming. The importance of global warming and air quality to society caused the National Research Council to recommend that NASA develop the following three missions^{1,2} ASCENDS (Active Sensing of CO₂ Emissions over Nights, Days, and Seasons), GEOCAPE (Geostationary Coastal and Air Pollution Events), and GACM (Global Atmosphere Composition Mission). The importance of CO₂ and methane study is reflected in the successful operation of the Japanese Greenhouse gases Observing Satellite (GOSAT) monitoring those trace gases globally from orbit.³

Instrumentation; measurement; metrology; remote sensing; atmospheric composition; optical instruments; absorption; interferometry; Fabry-Perot.

I. INTRODUCTION

Accumulation of heat-absorbing gases and aerosols in the atmosphere can result in an enhanced "greenhouse" effect and cause warming of the Earth's climate. Understanding the budget of carbon dioxide in the atmosphere is an overriding need. For more than two decades it has been understood that a significant "missing sink" reduces the global annual increase in atmospheric CO₂ by almost a factor of two yet the mechanism for this sink remains unknown.² Discovering the location and nature of this loss mechanism is one of the chief goals of NASA's proposed ASCENDS mission.⁴ Locating sources and sinks from space is exceedingly difficult because they are expected to give rise to only about a 1 ppm change in the existing total CO₂ column (approaching 400 ppm) presently determined by a network of ground based measurement systems.^{5,6}

Though methane measurements are not specified in future NASA missions, the environmental changes have raised the importance of understanding CH₄ and its role in atmospheric chemistry and dynamics. In the decadal survey¹ it is stated that "to close the carbon budget, we would also address methane, but the required technology is not obvious at this time. If appropriate and cost-effective methane technology becomes available, we strongly recommend adding a methane

capability". In its 2007 report the International Panel on Climate Change⁶ identified methane as a key uncertainty in our understanding saying that the causes of recent changes in the growth rate of atmospheric CH₄ are not well understood. What we do know is that methane arises from a number of natural sources including wet lands and the oceans plus man made sources from agriculture, as well as coal and petroleum production and distribution. It has recently been pointed out that large amount of methane are frozen in the permafrost of Canada and Siberia⁵. There is a fear that melting of this permafrost driven by global warming may release large amounts of methane very suddenly further exacerbating climate change. Retrievals of CO₂ and CH₄ are presently available from MOPITT/TERRA, SCIAMACHY/ENVISAT, AIRS/AQUA, and NOAA/TOVS. However they mostly correspond to the upper troposphere concentrations that are less sensitive to surface carbon sources and sinks⁹.

Last year our group began a joint effort with Johns Hopkins Applied Physics Laboratory to investigate the possibility of developing a small unmanned aerial vehicle (UAV) equipped to measure greenhouse gases-particularly methane. Although we are targeting our system for smaller UAV's the sensor will be directly applicable to missions involving larger NASA UAV's such as Global Hawk or even missions utilizing manned aircraft. The goal of this research has been to develop small, simple detectors capable of measuring the total column of carbon dioxide (CO₂) and methane (CH₄) from space using reflected sunlight. Because of its reduced size, inherent ruggedness and simplicity this type of sensors may find a role as a satellite instrument for NASA or NOAA in the future. Another possibility is to be used as receivers in the detector part of future lidar missions¹⁰.

The design employs a Fabry-Perot interferometer and makes use of two features to achieve high sensitivity. The first is high spectral resolution enabling one to match the width of an atmospheric absorption feature by the solid etalon transmission line. The second is high optical throughput enabled by using multiple spectral lines simultaneously. For any species that one wishes to measure, this first feature is available while the use of multiple spectral features can be employed only for species with suitable spectra and freedom from interference in the same wavelength region. Over the last few years at GSFC we developed similar passive sensors for CO₂, O₂ and water vapor to measure atmospheric column

using scattered solar flux and tested them during two successful flight campaigns¹¹⁻¹⁵.

II. DESCRIPTION OF INSTRUMENT AND BASIC THEORY

Figure 1 shows the existing methane sensor developed using IRAD and Ignition funds and demonstrated its ability to measure methane absorption by actual measurement of the atmospheric column using a sun tracker to introduce sunlight into the instrument. We have also operated it looking directly at the ground and using scattered light from the surface. This is the way the sensor would be used from an aircraft or spacecraft platform. Light enters the instrument from the left, passes through a bandpass filter and is then split. One half goes directly to a detector and the other half pass through a Fabry-Perot interferometer tuned to transmit at wavelengths where methane absorbs light. The detector for this half then responds strongly to changes in the atmospheric methane. The sensor is using ~1600 nm light and has the capability of measuring CH₄ in the Earth environment.

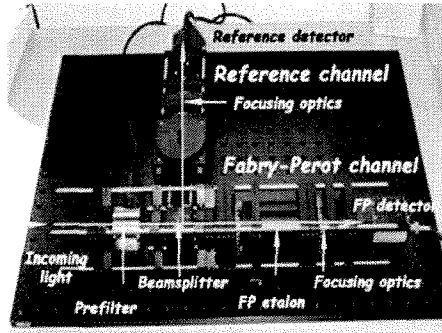

Figure 1: Mechanical Setup of the Fabry-Perot Detector for methane measurements

The instrument uses a solid Fabry-Perot etalon to restrict the measurement to light in CH₄ absorption bands. Light passing through the etalon undergoes multiple reflections on each inside surface, creating an interference pattern of evenly spaced fringes as a function of wavelength. At wavelengths where these fringes peak (constructive interference), light passes through the etalon. At the troughs of these fringes, (destructive interference) light is blocked. The width of the pass bands depends on the coatings quality and on the flatness and parallelism of the surfaces. The Fresnel formalism gives the reflected and transmitted amplitude components for the light wave as functions of the optical constants of the two media and the angle of incidence. The resulting intensity follows the Airy function distribution pattern. The ideal Fabry-Perot etalon with perfectly flat surfaces transmits a narrow spectral band and the energy transmission coefficient I_T is given by¹⁶:

$$I_T = \frac{T^2}{(1-R)^2} \left[1 + \frac{4R}{(1-R)^2} \sin^2 \left(\frac{2\pi n d \cos \theta}{\lambda} \right) \right]^{-1}$$

where λ is the wavelength, n is the refractive index, d is the thickness of the etalon and θ is the angle of incidence within the cavity, T is the intensity transmission coefficient for each coating and R is the intensity reflection coefficient.

We adjust the thickness of the etalon so that the separation (in frequency) of the transmitted fringes is equal to the almost constant separation of the CH₄ absorption lines. This is illustrated in Figure 2. By adjusting the angle of incidence of light passing through the Fabry-Perot the transmission fringes (yellow) can be brought into nearly exact correspondence with the CH₄ absorptions (blue). When this is done changes in the amount of CH₄ in the atmosphere strongly affect the amount of light transmitted by the Fabry-Perot. A narrow-band filter (passband shown in red) is used to confine the overall spectral band pass of the instrument to the region from 1633 to 1653 nm.

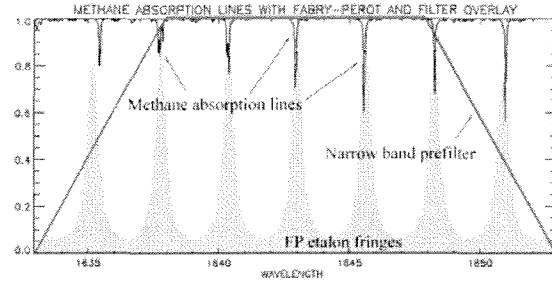

Figure 2 Modeling results for the methane absorption lines and FP transmission

III. EXPERIMENTAL

A. Laboratory and field data taken with the CH₄ sensor

When the instrument works as a ground based sensor the CH₄ column is measured through absorption of light by CH₄ in the atmosphere directly between the sun and the ground instrument. We accomplished this by collecting light with a small telescope fixed to an equatorial mount, aligned to track the sun throughout the day. An optical fiber coupled at the rear of the collimator brings light into the instrument. We used wedge prisms in the optical path to adjust the angle of incidence of the light on the Fabry-Perot. We attempted to align the passbands of the FP so that one of them coincided with the methane line located at 1637.8 nm.

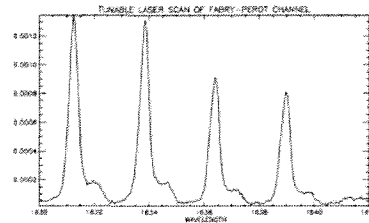

Figure 3 Scan of the FP channel when the instrument was first assembled

Figure 4 illustrates a typical data set collected over the course of a clear day with the CH₄ sensor. The ratio of Fabry-Perot to

reference signals is a function of the time of day.

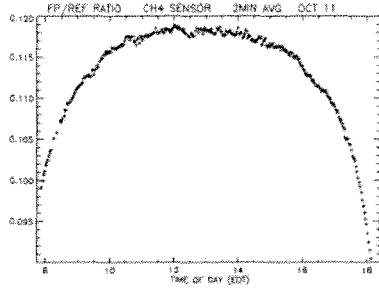

Figure 4 Ratio of the FP/Ref signals during the day

The arched shape arises because of the motion of the sun. Early in the morning and late in the evening when the sun is low in the sky the path through the atmosphere is long and the amount of absorption caused by the CH₄ is large. Near noon the path through the atmosphere is the shortest so the amount of absorption is less and the ratio of the FP channel to the reference channel is greatest. We can calculate the length of the path through the atmosphere for different times of the day and the next plot shows the same data plotted against this "airmass". An airmass of one is obtained when the sun is directly overhead. Figure 5 shows the same data plotted as a function of the calculated airmass. The airmass decreases all morning until local noon and then increases until sunset.

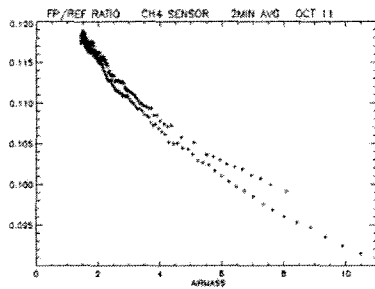

Figure 5 Methane column absorption as a function of airmass

The two branches of the plot versus airmass show that the total column methane changed slightly during the day so that the afternoon absorption is slightly stronger than the morning absorption.

The last result we wish to present is a plot obtained using the instrument to measure methane employing light scattered up from the ground. This is the mode in which the instrument would be used if it were on an aircraft or a satellite. The ratio is a little bit noisier than that in fig. 4 and 5 (the signal from ground scattering is 1000 times weaker than direct viewing of the sun) but this does demonstrate that the instrument is capable of measuring the methane column abundance from a satellite.

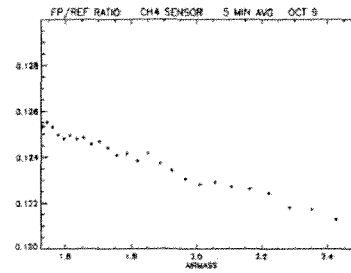

Figure 6 Ratio when collecting light reflected off the ground

Figure 7 is a plot of the data collected with both the CO₂ and CH₄ sensors.

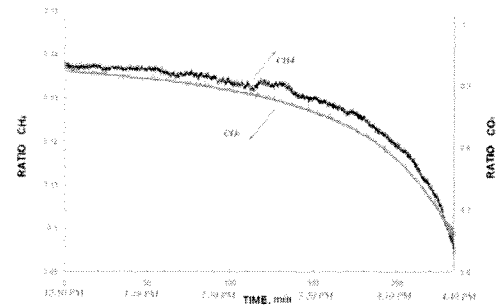

Figure 7: Data collected on December 29 with a sun tracker.

B. New sensor design

We are working now on an improved carbon dioxide and methane sensors which will use a CCD array to sample both the reference and the Fabry-Perot signal simultaneously on different areas of the array. It will increase the signal to noise ratio (SNR) while permitting a reduction in the overall size of the instrument.(Figure 8)

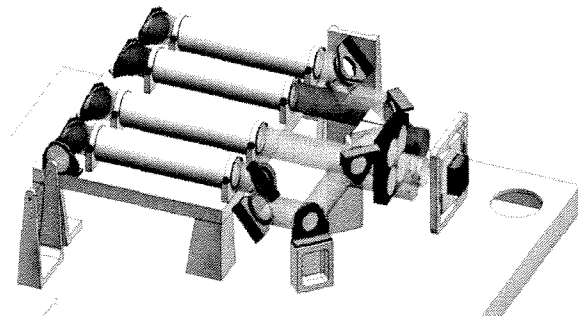
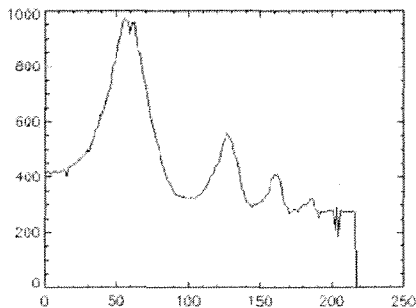
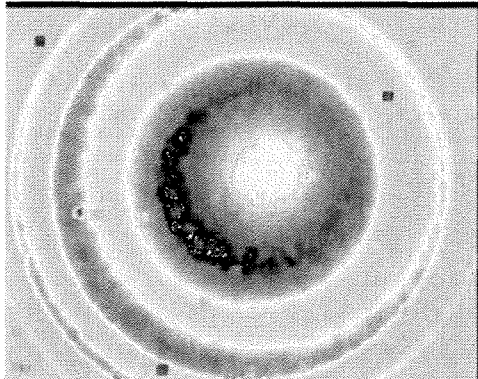

Figure 8: A representation of the physical design of the small-size CO₂ instrument

Our new design will use a Fabry-Perot interferometer plus a focal plane array in place of a single diode detector. In addition to being used as a passive sensor this offers a new capability to spectrally resolve lidar signals; moreover the arrays provide outstanding noise characteristics that improve the ability to make precise measurements of the very small anticipated return signals for LIDARS operating from space.

Figure 9 represents a Fabry-Perot illuminated by a single wavelength laser producing the ring pattern shown on the left. Summing the signals around the rings and binning by radius in pixels yields the plot on the right. This is a spectrum that repeats over the free spectral range of the Fabry-Perot.



IV. CONCLUSIONS

Limited testing demonstrates that our Fabry-Perot based differential radiometer has the ability to measure the carbon dioxide and methane column both as a ground based instrument as well as from an airborne platform. Further work to improve the light gathering properties of the instrument's

front end and tuning of the Fabry-Perot bandpass should increase the sensitivity and response time.

REFERENCES

- [1] Earth Science and Applications from Space: National Imperatives for the Next Decade and Beyond, Committee on Earth Science and Applications from Space: A Community Assessment and Strategy for the Future, National Research Council.
- [2] Responding to the Challenge of Climate and Environmental Change: NASA's Plan for a Climate-Centric Architecture for Earth Observations and Applications from Space, June 2010.
- [3] Suto H., Kawashima T., Shiomi K., Kina T., Kuze A., Urabe T., Kawakami S., Kaneko Y. and Hamazaki T., The performance test results for Engineering Model (EM) of Thermal And Near infrared Sensor for carbon Observation (TANSO) on GOSAT, Proc. of SPIE Vol. 6678, 667815, pp. 667815-1- 667815-9, 2007.
- [4] Active Sensing of CO₂ Emissions over Nights, Days, and Seasons (ASCENDS) Mission, NASA Science Definition and Planning Workshop Report, University of Michigan in Ann Arbor, Michigan.
- [5] Sarmiento J L, Gruber N., Sinks for Anthropogenic Carbon, Physics Today, pp. 30-36.2002.
- [6] O'Brien D. M., Rayner P. J., Global observations of the carbon budget 2. CO₂ column from differential absorption of reflected sunlight in the 1.61 mm band of CO₂, Journal of Geophysical Research, vol. 107 (D18), Art.No 4354, pp.1-16, 2002.
- [7] U.S. Global Carbon Cycle Science Program 2007, Highlights of Recent Research and Plans for FY 2007, Chapter 5, pp.114-120, 2007.
- [8] Katey Walter Anthony: Methane: A Menace Surfaces, Scientific American, December, pp. 69-75, 2009.
- [9] Alexander P. Trishchenko et al, An approach for retrieval of atmospheric trace gases CO₂, CH₄ and CO from the future Canadian Micro Earth Observation Satellite (MEOS), Proc. of SPIE Vol. 6744, 674420, pp. 674420-1- 674420-9, 2007.
- [10] Heaps W.S., E. Georgieva, W. Huang, Broadband Lidar technique for precision CO₂ measurement, AGU Fall meeting, San Francisco, December, 2009.
- [11] Georgieva E.M., Wilson E.L., Miodek M., Heaps W.S., "Total Column Oxygen Detection Using Fabry-Perot Interferometer", Optical Engineering, vol. 45 (11), Paper No115001, Nov., pp.1-11, 2006.
- [12] W.S. Heaps, E.L. Wilson, E.M. Georgieva, "Precision Measurement of Atmospheric Trace Constituents Using a Compact Fabry-Perot Radiometer", International Journal of High Speed Electronics and Systems, accepted, February, 2007.
- [13] E.L. Wilson, E. M. Georgieva, W. S. Heaps, "Development of a Fabry-Perot interferometer for ultra-precise measurements of column CO₂", Measurement Science and Technology, Vol. 1, pp. 1495-1502, 2007.
- [14] Georgieva, E.M., Wilson E.L., and W.S. Heaps, "Precise measurement of CO₂ from space using Fabry-Perot based optical setup: current status and development", ProcSPIE Earth Observing Systems XI, vol.6296, pp.62961G-62961G-12, 2006.
- [15] Georgieva, E.M. Wilson, M. Miodek and W.S. Heaps, "Atmospheric column CO₂ and O₂ absorption based on Fabry-Perot etalon for remote sensing", Proc. SPIE Earth Observing Systems X, vol.5882 , pp.58820G-1-58820G-9, 2005.
- [16] Hernandez G., Fabry-Perot Interferometers, Cambridge, New York, 1986.
- [17] Bolin, B., The carbon cycle, Sci. Amer. 223(3), pp. 124-132, 1970.