

Advanced Development of a Compact 5-15 lbf Lox/Methane Thruster for an Integrated Reaction Control and Main Engine Propulsion System

*Eric Hurlbert
John Patrick Mcmanamen
Josh Sooknanen
Joseph W. Studak*

*NASA Johnson Space Center
Houston, Texas 77058*

This paper describes the advanced development and testing of a compact 5 to 15 lbf LOX/LCH₄ thruster for a pressure-fed *integrated* main engine and RCS propulsion system to be used on a spacecraft “vertical” test bed (VTB). The ability of the RCS thruster and the main engine to operate off the same propellant supply in zero-g reduces mass and improves mission flexibility. This compact RCS engine incorporates several features to dramatically reduce mass and parts count, to ease manufacturing, and to maintain acceptable performance given that specific impulse (Isp) is not the driver. For example, radial injection holes placed on the chamber body for easier drilling, and high temperature Haynes 230 were selected for the chamber over other more expensive options. The valve inlets are rotatable before welding allowing different orientations for vehicle integration. In addition, the engine design effort selected a coil-on-plug ignition system which integrates a relay and coil with the plug electrode, and moves some exciter electronics to avionics driver board. The engine injector design has small dribble volumes to target minimum pulse widths of 20 msec. and an efficient minimum impulse bit of less than 0.05 lbf-sec. The propellants, oxygen and methane, were chosen because together they are a non-toxic, Mars-forward, high density, space storable, and high performance propellant combination that is capable of pressure-fed and pump-fed configurations and integration with life support and power subsystems. This paper will present the results of the advanced development testing to date of the RCS thruster and the integration with a vehicle propulsion system.

Vehicle Subsystem Integration of Oxygen and Methane Propulsion Systems

One of the motivations for developing oxygen based propulsion for human spacecraft is to enable common fluids between life support, power, and propulsion as shown figure 1. Liquid oxygen is an obvious choice given it is critical to life support and is used in spacecraft power systems, where it is typically stored as a cryogenic fluid. The choice of fuel is more dependent on other factors, such as storage density, combustion characteristics, etc. One such characteristic is that both propellants vaporize easily and burn clean, which is a benefit in a vacuum for short pulses of thrusters. In addition, methane has hardware commonality with liquid oxygen tanks and feed systems. Methane is in a sense a product of life. It is interesting to note that on ISS, there is enough methane produced to fuel a smaller lander to go to the moon. Looking forward, together

oxygen and methane are also a good candidate for In-Situ Resource Utilization (ISRU) technologies that are able to produce propellants on the surface of Mars.

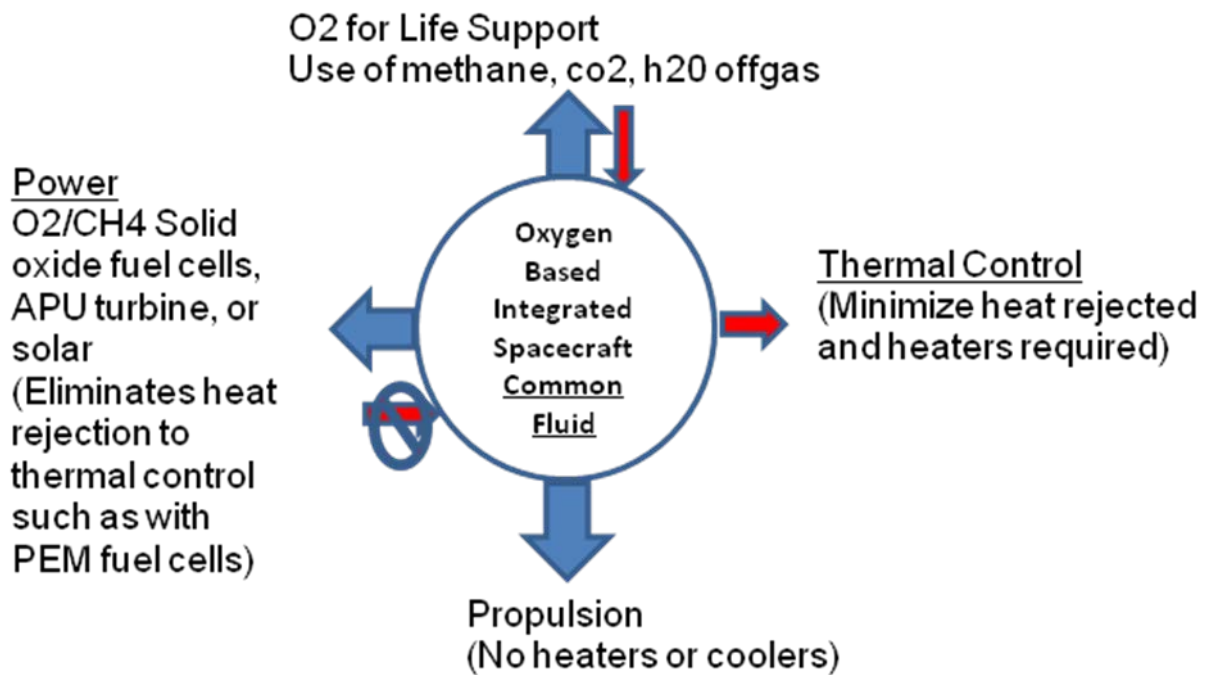

Figure 1. Common Fluids for Spacecraft Power, Propulsion, and Life Support

However, the use of cryogenic propellants presents several vehicle integration issues and questions that need to be addressed.

1. Can a small (5-15 lbf) cryogenic thruster provide repeatable pulses given that some variation in propellant quality can be expected?
2. How can propellant quality be maintained without wasting the propellants or without requiring complex cryo-cooler systems?
3. How should the ignition system for multiple (16 or more) RCS engine be architected to reduce complexity, wiring, and weight, given that previous excitors for space use have not been optimized for RCS applications?

Objectives and Approach of Testing

Starting in April 2010, a small advanced development effort was started under Project Morpheus to address these questions and to build a set of robust RCS thrusters for test vehicle, Morpheus. Although the Morpheus vehicle RCS feed system is designed to control propellant conditions, the RCS thruster is being tested over a wide range of propellant conditions from gaseous to two-phase to sub-cooled liquid, thus insuring robust and reliable thruster operation on the vehicle. These tests are being conducted at ambient pressure conditions using a small thruster test capability called the "cryo-carts" at the Energy System Test Area (ESTA). These "cryo-cart" test rigs were developed for

ISRU field demonstrations in Hawaii, but have proven themselves to be low cost and useful to Project Morpheus.



Figure 2. "Cryo-Cart" test stand ESTA

Early Testing of an Igniter Converted to a Thruster

Initially, a small igniter from the Aerojet 870 lbf engine ^{ref 1,2} was converted to a thruster for use as an early proof of concept. Under the Propulsion & Cryogenics Advanced Development (PCAD) project, this igniter was tested at WSTF over a wide range of inlet conditions at vacuum, where it demonstrated reliable ignition even with the propellant initially two phase at start.



Figure 3. Aerojet 870 lbf engine igniter, chamber, and hot fire picture

For Project Morpheus, a stainless steel chamber was fabricated as shown figure 3, and installed on the Cryo-Cart test stand. In November of 2010, a total of 74 test sequences, with 378 total pulses were conducted over a range of inlet pressures and temperatures. These tests included 10 sec single pulses, 34 pulse runs at 25% duty cycle with engine pulse width (EPW) of .5 sec, and 50 pulse runs at 50% duty cycle with EPW of .150 sec. An example is shown in Figure 4, which is an initial 5 second burn followed by 0.5 sec pulse sequence at 25% duty cycle with no temperature control of the line, such that the propellant condition became two-phase over time.

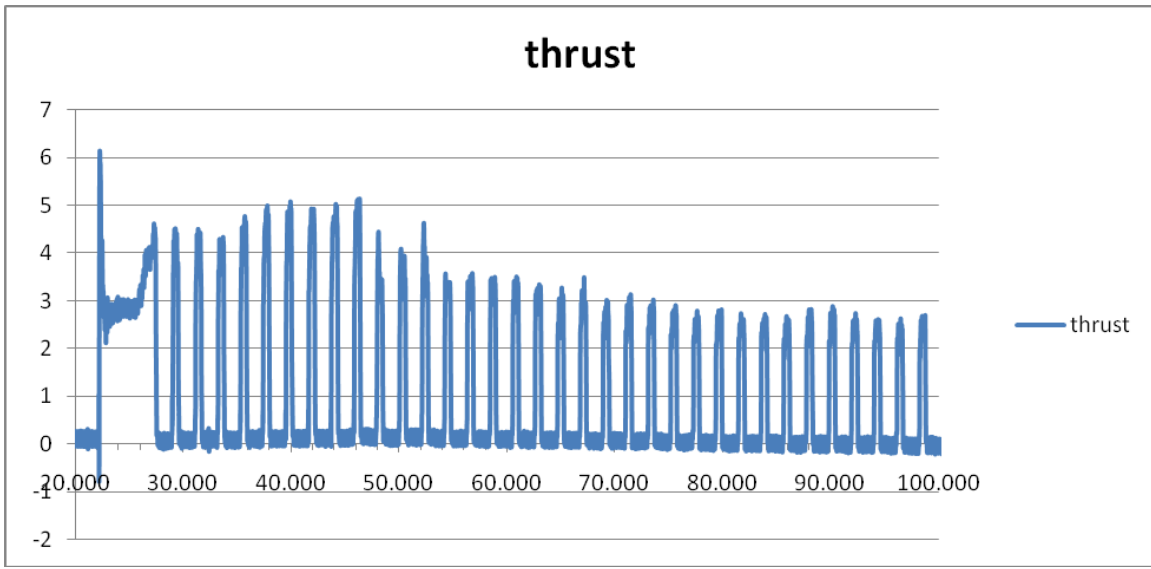

Figure 4. Hot-fire Run#11: Profile 5 sec pulse followed by EPW of 0.5 sec at 25% duty cycle

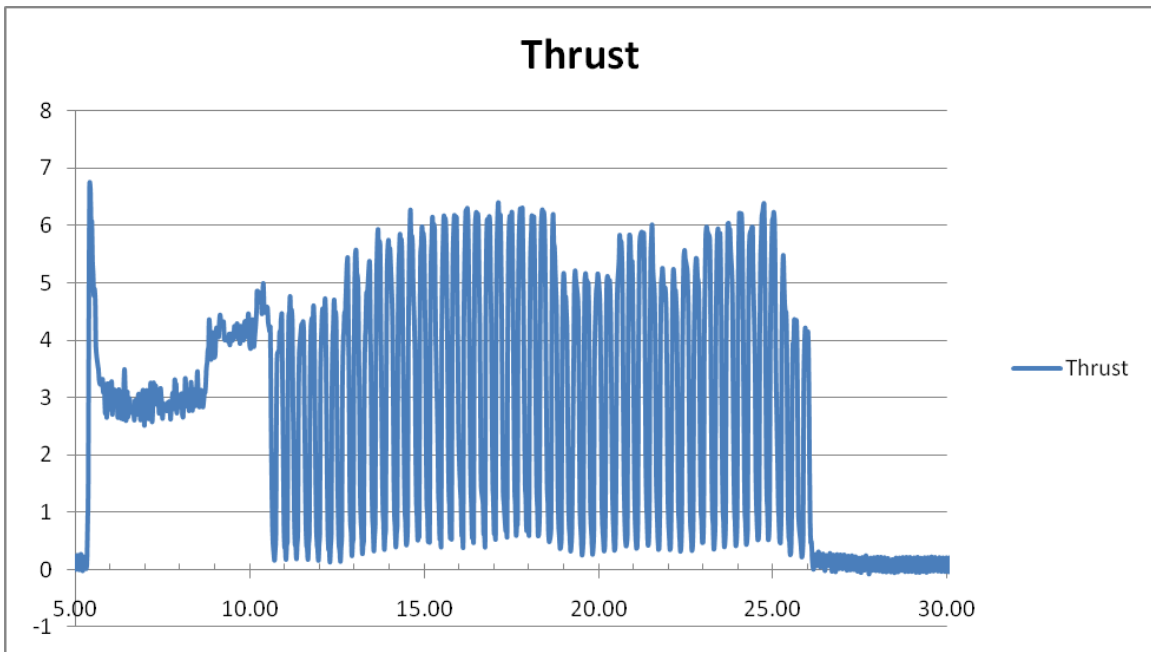

Figure 5. Hot Fire #14: Profile 5 second run followed by 50 pulses at EPW=0.150 and 50% duty cycle

Figure 5 was a test performed to see behavior under duty cycles where the thruster is rapidly pulsed. The inlet conditions were 300 psig LO2 and 250 psig fuel. The thrust variations were from 3 to 6 lbf. Although this behavior can be improved by controlling feed line conditions as demonstrated in feed system testing, it is significant that even in

this over-test condition, that the thruster performed reliably, and produced thrust from 3 to 6 lbf. The acceptability of this variation in thrust for vehicle control will be demonstrated in planned tests on the vertical test bed (VTB) vehicle.

Prototype Compact RCS Thruster

The Aerojet igniter tests proved the basic concept and design for small thrusters from around 5 lbf to 15 lbf. The next step was to develop a thruster that could be made easily in significant numbers for the Project Morpheus lander. This new compact RCS engine incorporates several features to dramatically reduce mass and parts count, to ease manufacturing, and to increase performance. For example, radial injection holes placed on the chamber body and high temperature Haynes 230 were selected for the thruster design. The valve inlets are rotatable before welding allowing different orientations for vehicle integration. In addition the engine design effort investigated a coaxial coil-on-plug ignition system which integrates the coil and plug electrode, and moves the electronics to jet driver board. The engine design incorporates fast valves and small dribble volumes targeted for minimum pulse widths of 20msec, and efficient minimum impulse bits of less than 0.05 lbf-sec.

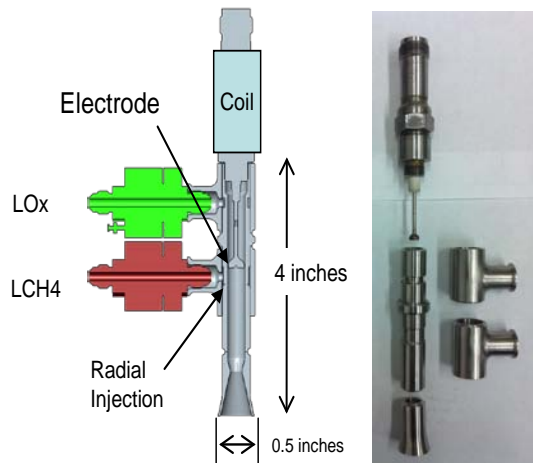

Figure 6. Compact Thruster

Thruster Spark Ignition System Integration with the Vehicle

Typically the current space qualified ignition systems, which have been used for upper-stage engines such as the J2X and RL10 engine, are rather large and weigh more than 5 lbs. These are typically purged boxes with long cable leads. These solutions have worked well for main engines, however it would be excessively heavy to have one of these for each RCS engine, which could number from 8 to 24 jets.

Another enhancement would be to need only three wires for each thruster that would power the thruster valves and the exciter. These three wires would be power, spark signal, and a common ground. The power wire would supply both the valve coils and the

ignition coil. The coil would have a built-in relay switch that is driven by a low voltage timing signal from the avionics box.

The solution for these problems is from the automotive industry. The industry has moved towards coil-on-plug solution, which has 12 volt power connected to the coil and a timing signal wire. The only electronics in or near the coil is a relay switch which is operated by timing signal from the computer. The coils themselves are fully potted and would be suitable for vacuum operation. By potting this connection of the coil directly to the plug electrode, the issue with corona can be eliminated that has been seen with long spark plug cable connections between the plug and the exciter box.

Integrated RCS Thruster Tests on Vehicle using a Vertical Test Bed

The compact 5-15 lbf thruster will be undergoing testing on the “Cryo-Cart” test stand prior to flying a vertical test bed that integrates the RCS thrusters with a throttling main engine on a common feed system. Four or more of these engines will be installed to provide pitch control of the vehicle in addition to the gimballed main engine, as shown in figure 7. This common RCS and main engine feed system operates at typical pressures of 250 to 500 psia with highly sub-cooled liquid oxygen and liquid methane (or liquefied natural gas). The vehicle feed system design incorporates some propellant temperature conditioning techniques that insure repeatable pulses.

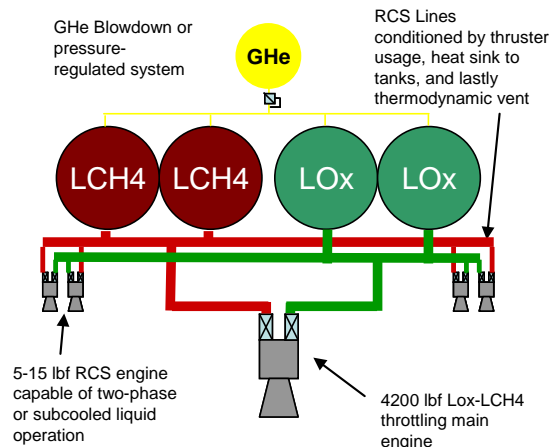

Figure 7. Integrated RCS and Main Engine Simplified Schematic

The vertical test bed, which has been co-developed on a cooperative agreement with Armadillo Aerospace, is to be a test vehicle for spacecraft sub-systems applicable to a multitude of possible NASA missions, not only a lander but also in-space human spacecraft. The first version shown in figure 8 of this lander called Pixel or risk reduction 1 (RR1) flew several times recently in May – July 2010.



Figure 8. Armadillo Aerospace Pixel Lander (RR1) modified to run on Lox/Methane during free flight on July 25, 2010.

A 2nd lander, called Morpheus, with provisions for RCS feed system integration has been built as shown in figure 9a and 9b. This lander integrates all subsystems software, avionics, power, propulsion, and structures. From an RCS technology development perspective, it provides an excellent test vehicle since the propulsion system is essentially flight-weight and flight geometry, and uses flight software and avionics. From a spacecraft test bed perspective, having this low-cost RCS engine provides enhanced control capability for flying some challenging trajectories.

The integration of the RCS feedsystem can be done in a manner to improve thruster performance. The RCS thrusters on Morpheus will be installed by mounting them outboard on the propellant tanks. This will allow the RCS lines to be heat-sinked to the propellant tanks. This will help keep the propellant to the RCS thrusters conditioned thereby improving impulse bit repeatability. A thermodynamic vent system (TVS) valve can also be used to further condition the propellant at the thruster valve-to-feedsystem interface. This propellant which is being vented would not be wasted, it would instead be used for power, life support, or a small cold gas thruster for even smaller impulse bits.

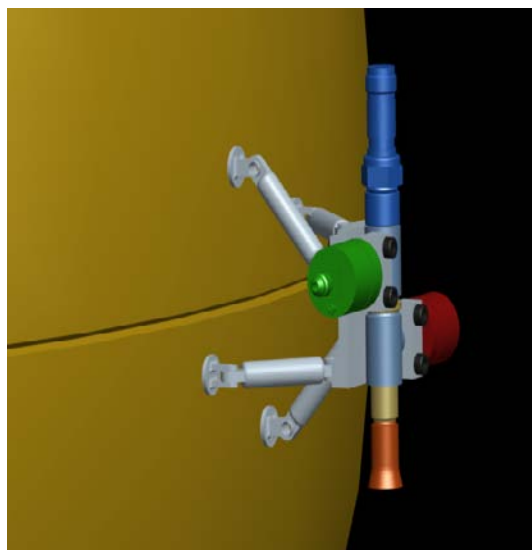
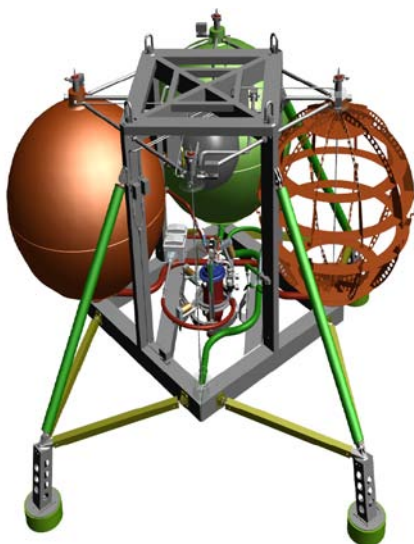

Figure 9a and 9b. Cutaway of 2nd Morpheus (RR2) lander test vehicle and final assembly stage of the vehicle



Conclusion

This effort made some progress on addressing some of the key questions and objectives; 1) can small cryogenic thrusters provide repeatable pulses given that some variation in propellant quality can be expected, 2) how can propellant quality be maintained without wasting the propellants or without requiring complex cryo-cooler systems; 3) how should the ignition system be architected for multiple (16 or more) RCS engine to reduce complexity, wiring, and weight; and 4) how to design a compact thruster for manufacturability and low cost.

The test results of the Aerojet igniter at ESTA, where it was converted to a thruster, and previously at WSTF, demonstrated the concept that a small cryogenic thruster can provide a reliable pulse. The variability in thrust was measured from over a range of propellant inlet conditions. These results showed that if the propellants are initially conditioned, then pulses are repeatable. As the inlet conditions warm up and the flow becomes partially gas, then the thrust drops approximately in half. Discussions with vehicle control system engineers have indicated that this can be tolerated. Operation in a gas-gas mode should provide an efficient minimum impulse bit that is well suited to low duty cycle operations in a vacuum. This will be explored in future vehicle tests on Morpheus.

There are several ways by which this thruster minimizes volume, mass, and power impacts to the vehicle. By using liquid oxygen and liquid methane, this RCS thruster can

integrate directly with a main engine feed system and tanks. This provides significant mass savings by eliminating separate tanks and enhances flexibility in the mission propellant budgets. The compact packaging, the coil-on-plug, and the simplified wiring further reduce vehicle impacts. LO₂/methane also do not require any heaters for maintain temperature which can be a major power draw for spacecraft.

In addition this technology development effort was compact in its execution as well. To rapidly make progress on the key RCS questions at the vehicle level, the vertical test bed provides an excellent test vehicle since the propulsion system is essentially flight-weight and flight geometry, and uses flight software and avionics. This allows the major objectives to be addressed such as the effect of pulse repeatability and how to architect the integrated solution. From a Morpheus lander perspective, having this low-cost RCS engine provides the control capability for flying some challenging trajectories. This will be the focus of future test activities.

References:

1. Robinson, Philip J.; Veith, Eric M.; Turpin, Alicia A., "Test Results for a Non-toxic, Dual Thrust Reaction Control Engine", 41st AIAA/ASME/SAE/ASEE Joint Propulsion Conference, 11-13 Jul. 2005, Tucson, AZ, United States, AIAA Paper 2005-4457.
2. NASA/TM-2010-216135 Test Report for 870-lbf Reaction Control System Tests Using Liquid Oxygen/Ethanol and Liquid Oxygen/Methane at White Sands Test Facility