



Method of Real-Time Principal-Component Analysis

Hardware can be simplified.

NASA's Jet Propulsion Laboratory, Pasadena, California

Dominant-element-based gradient descent and dynamic initial learning rate (DOGEDYN) is a method of sequential principal-component analysis (PCA) that is well suited for such applications as data compression and extraction of features from sets of data. In comparison with a prior method of gradient-descent-based sequential PCA, this method offers a greater rate of learning convergence. Like the prior method, DOGEDYN can be implemented in software. However, the main advantage of DOGEDYN over the prior method lies in the facts that it requires less computation and can be implemented in simpler hardware. It should be possible to implement DOGEDYN in compact, low-power, very-large-scale integrated (VLSI) circuitry that could process data in real time.

For the purposes of DOGEDYN, the input data are represented as a succession of vectors measured at sampling times t . The objective function [the error measure (also called "energy" in the art) that one seeks to minimize in gradient-descent iterations] is defined by

$$J(w) = \sum_{i=1}^m J_i(w_i) = \sum_{i=1}^m \sum_{t=1}^k |x_t - w_i w_i^T x_t|^2$$

where m is the number of principal components, k is the number of sampling time intervals (the number of measurement vectors), x_t is the measured vector at time t , and w_i is the i th principal vector (equivalently, the i th eigenvector). The term $J_i(w_i)$ in the above equation is further expanded by

$$J_i(w_i) = \sum_{t=1}^k |y_t - w_i w_i^T y_t|^2$$

and

$$y_t = x_t - \sum_{j=1}^{i-1} w_j w_j^T x_t$$

The learning algorithm in DOGEDYN involves sequential extraction of the

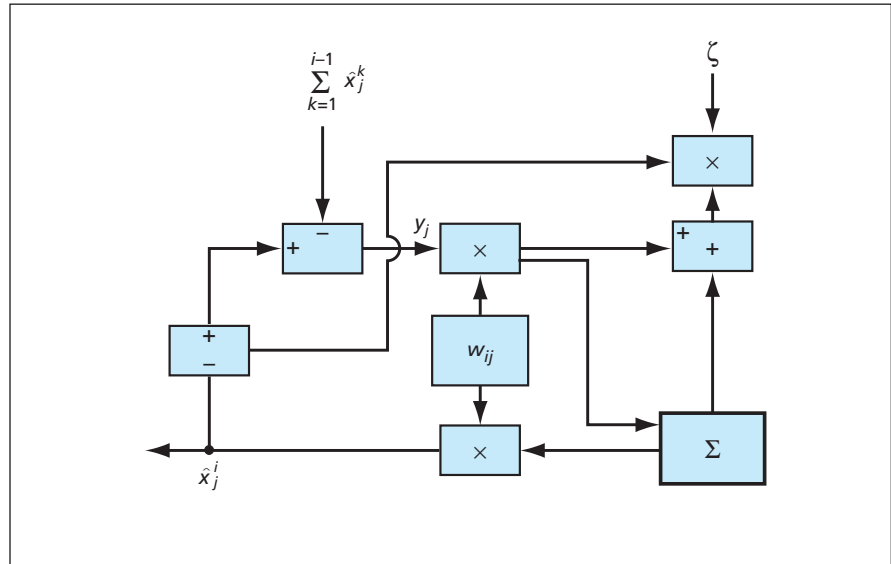

The Hardware Represented by This Diagram can be regarded as a unit that can be cascaded to obtain as many parallel eigenvector extractors as needed in a given application. The cascaded, identical units can be fabricated on a single integrated-circuit chip.

principal vectors by means of a gradient descent in which only the dominant element is used at each iteration. Omitting details of the mathematical derivation for the sake of brevity, an iteration includes updating of a weight matrix according to

$$W_{ij}^{\text{new}} = W_{ij}^{\text{old}} + \zeta \Delta w_{ij} = W_{ij}^{\text{old}} + \zeta \mathcal{E}_{ij} (w_i^T y_i + w_{ij} y_{ij})$$

where w_{ij} is an element of the weight matrix and ζ is the dynamic initial learning rate, chosen to increase the rate of convergence by compensating for the energy lost through the previous extraction of principal components. The value of the dynamic learning rate is given by

$$\zeta = \frac{E_0}{E_{i-1}}$$

where E_0 is the energy at the beginning of learning and E_{i-1} is the energy of the $i-1$ st extracted principal component.

The figure depicts a hardware architecture for implementing DOGEDYN. The raw input data, here denoted x_j ,

are subtracted from the sum of the data previously projected on the previous principal components to obtain y_j (which is equivalent to y_t as defined above, after appropriate changes in subscripts). The Σ box calculates the inner product of vectors y and w_i . The output of the Σ box is summed with the previously computed product of y_j and w_{ij} and the result multiplied by the dynamic learning rate before updating of w_{ij} .

This work was done by Tuan Duong and Vu Duong of Caltech for NASA's Jet Propulsion Laboratory. Further information is contained in a TSP (see page 1).

In accordance with Public Law 96-517, the contractor has elected to retain title to this invention. Inquiries concerning rights for its commercial use should be addressed to:

Innovative Technology Assets Management
JPL

Mail Stop 202-233

4800 Oak Grove Drive

Pasadena, CA 91109-8099

(818) 354-2240

E-mail: iaoffice@jpl.nasa.gov

Refer to NPO-40034, volume and number of this NASA Tech Briefs issue, and the page number.