

Gifford-McMahon/Joule-Thomson Refrigerator Cools to 2.5 K

This system is relatively simple.

NASA's Jet Propulsion Laboratory, Pasadena, California

A compact refrigerator designed specifically for cooling a microwave maser low-noise amplifier is capable of removing heat at a continuous rate of 180 mW at a temperature of 2.5 K. This refrigerator is a combination of (1) a commercial Gifford-McMahon (GM) refrigerator nominally rated for cooling to 4 K and (2) a Joule-Thomson (J-T) circuit. The GM refrigerator pre-cools the J-T circuit, which provides the final stage of cooling. The refrigerator is compact and capable of operating in any orientation. Moreover, in comparison with a typical refrigerator heretofore used to cool a maser to 4.5 K, this refrigerator is simpler and can be built at less than half the cost.

The figure is a flow diagram of the refrigerator. The GM refrigerator comprises two stages. The first GM stage nominally provides 50 W of cooling power at a temperature of 50 K. The second GM stage nominally provides 1.5 W at 4.2 K. The working fluid of the J-T circuit is helium, which is supplied at ambient temperature at a pressure of 110 kPa. The J-T helium is circulated by means of a commercial scroll vacuum

pump that does not use any oil and hence does not contaminate the helium.

In the J-T circuit, the helium flowing toward a cold plate (the final, coldest stage) passes through a first-stage counterflow heat exchanger, where it is cooled by the helium in the return flow that has passed from the cold plate through a second-stage counterflow heat exchanger. The helium then passes through the first GM stage, where it is cooled to a temperature between 35 and 40 K. After the first GM stage, the helium flows through the second-stage counterflow heat exchanger, wherein it is cooled by helium returning from the cold plate. The helium then passes through the GM second stage, where it is cooled to between 3.5 and 4.2 K.

The flow is then throttled by means of an externally adjustable expansion valve (a J-T valve) to the final-stage (cold-plate) operating temperature and pressure. The temperature at the final stage is the saturation temperature of helium at the pressure in that stage. From the final stage, the helium returns through the heat exchangers as mentioned be-

fore, and is then compressed back to the supply pressure and recycled.

The cooling to ≤ 4.2 K in the GM second stage makes it possible to liquefy the helium immediately prior to the J-T expansion. This enables the refrigerator to operate without the third-stage heat exchanger that would otherwise be needed in the J-T circuit. Elimination of the third-stage heat exchanger reduces both the cool-down time and the complexity of the system.

During cool-down, helium is supplied from an external helium bottle through a regulator that maintains its pressure at 110 kPa. Once the cooler has reached thermal equilibrium, no more helium is supplied from the external bottle. Thereafter, an external buffer tank accommodates small changes in the helium pressure with changes in the cooling load, and an external relief valve prevents the pressure from rising above 130 kPa.

This work was done by Michael Britcliffe, Jose Fernandez, and Theodore Hanson of Caltech for NASA's Jet Propulsion Laboratory. Further information is contained in a TSP (see page 1). NPO-30661

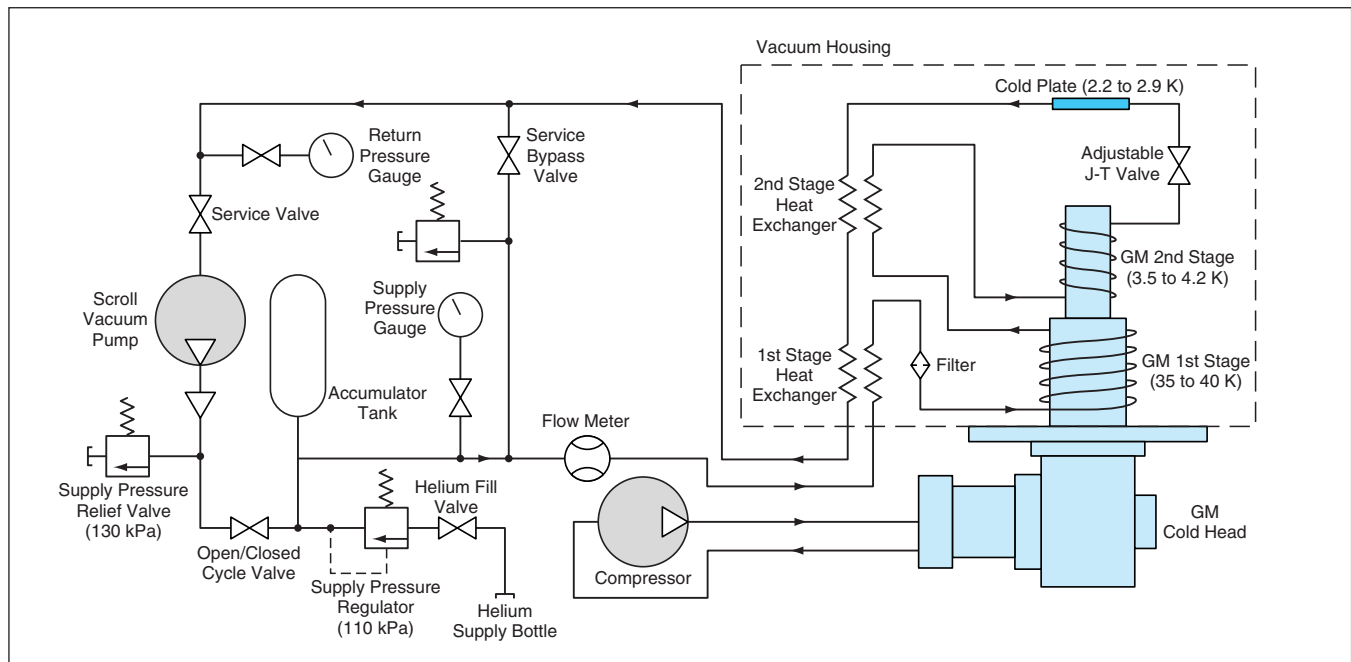

This Refrigeration System is a combination of a commercial Gifford-McMahon refrigerator and a simplified Joule-Thomson circuit.