



## Modified Penning-Malmberg Trap for Storing Antiprotons

One set of electrodes is used for both transmission and reception.

Marshall Space Flight Center, Alabama

A modified Penning-Malmberg trap that could store a small cloud of antiprotons for a relatively long time (weeks) has been developed. This trap is intended for use in research on the feasibility of contemplated future matter/antimatter-annihilation systems as propulsion sources for

spacecraft on long missions. This trap is also of interest in its own right as a means of storing and manipulating antiprotons for terrestrial scientific experimentation.

The use of Penning-Malmberg traps to store antiprotons is not new. What is new here is the modified trap design, which utilizes state-of-the-art radio-frequency (RF) techniques, including ones that, heretofore, have been used in radio-communication applications but not in ion-trap applications.

A basic Penning-Malmberg trap includes an evacuated round tube that contains or is surrounded by three or more collinear tube electrodes. A steady axial magnetic field that reaches a maximum at

the geometric center of the tube is applied by an external source, and DC bias voltages that give rise to an electrostatic potential that reaches a minimum at the center are applied to the electrodes. The combination of electric and magnetic fields confines the charged particles (ions or electrons) for which it was designed to a prolate spheroidal central region. However, geometric misalignments and the diffusive cooling process prevent the steady fields of a basic Penning-Malmberg trap from confining the particles indefinitely.

In the modified Penning-Malmberg trap, the loss of antiprotons is reduced or eliminated by use of a "rotating-wall" RF stabilization scheme that also heats the antiproton cloud to minimize loss by matter/antimatter annihilation. The scheme involves the superposition of a quadrupole electric field that rotates about the cylindrical axis at a suitably chosen radio frequency.

The modified Penning-Malmberg trap (see Figure 1) includes several collinear sets of electrodes inside a tubular vacuum chamber. Each set comprises either a single metal tube or else a tube that is segmented into four electrodes that subtend equal angles about the cylindrical axis. The output of an RF signal generator is fed through a 90° hybrid coupler and then through two baluns to generate four replicas of the signal at relative phase shifts of 0°, 90°, 180°, and 270° (see Figure 2). These signal replicas are fed through -6-dB directional couplers, then via coaxial cables to the vacuum chamber. The signal is then routed to a phase cancellation network, which filters out the drive signal with the difference representing the plasma interaction. Inside the vacuum chamber, twisted-pair wires feed the signals from the coaxial cables to the four electrodes of each segmented electrode tube.

It is not necessary to use a different set of electrodes for moni-

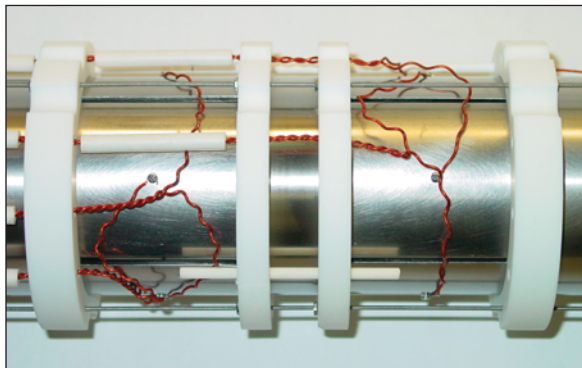

Figure 1. The **Modified Penning-Malmberg Trap** includes electrode tubes separated by insulating rings. Some of the tubes are segmented into four electrodes each.

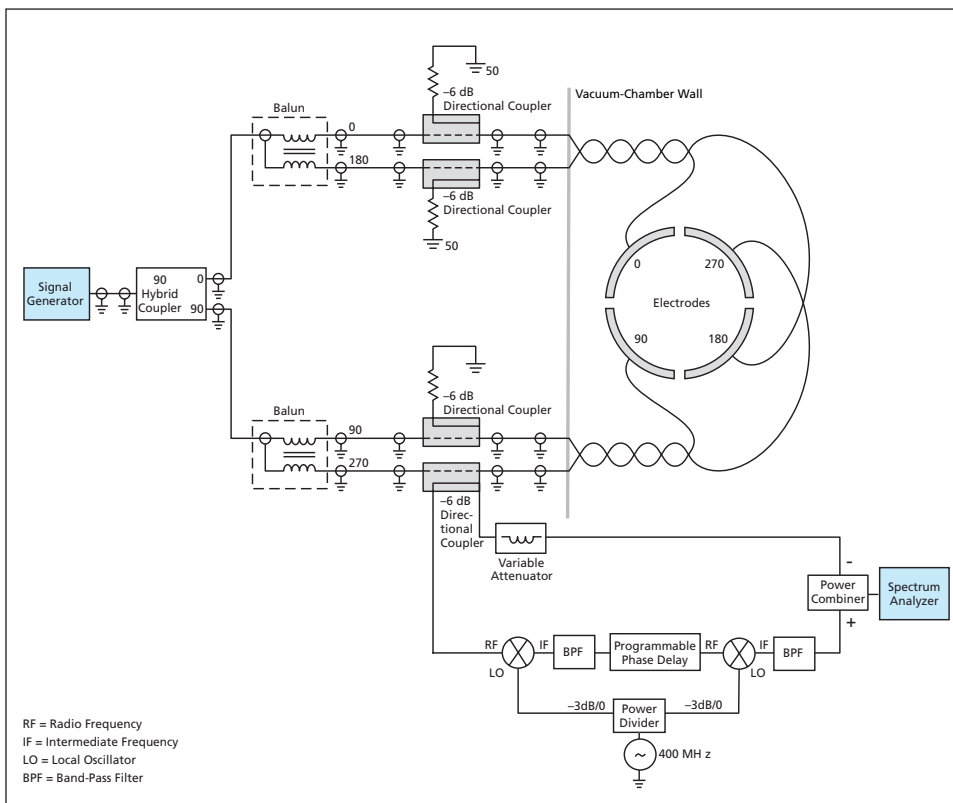

Figure 2. This **Radio-Frequency Circuit** enables simultaneous application of the RF stabilizing signal and monitoring of the RF response of the cloud of antiprotons confined in the trap.

toring the antiproton cloud. Instead, the -6-dB directional couplers are used to receive the signal that emanates from the antiproton cloud when the cloud interacts with the applied signal. The received signal can be routed to either a spectrum analyzer or a network analyzer.

*This work was done by William H. Sims and James Martin of Marshall Space Flight Center, and Raymond Lewis of RLewis Co. Further information is contained in a TSP (see page 1).*

*This invention is owned by NASA, and a patent application has been filed. Inquiries*

*concerning nonexclusive or exclusive license for its commercial development should be addressed to the Patent Counsel, Marshall Space Flight Center, (256) 544-0021. Refer to MFS-31780.*

---

## Tumbleweed Rovers

**Lightweight balls containing scientific instruments are propelled across terrain by wind.**

*NASA's Jet Propulsion Laboratory, Pasadena, California*

Tumbleweed rovers, now undergoing development, are lightweight, inflatable, approximately spherical exploratory robotic vehicles designed to roll across terrain, using only wind for propulsion. Tumbleweed rovers share many features with "beach-ball" rovers, which were discussed in several prior *NASA Tech Briefs* articles. Conceived for use in exploring remote planets, tumbleweed rovers could also be used for exploring relatively inaccessible terrain on Earth.

A fully developed tumbleweed rover would consist of an instrumentation package suspended in an inflated two-layer (nylon/polypropylene) ball. The total mass of the rover would be of the order of 10 kg, the diameter of the ball when inflated would be 2 meters, and the minimum wind speed needed for propulsion would be about 5 m/s. The instrumentation package would contain

a battery power supply, sensors, a Global Positioning System (GPS) receiver, and a radio transmitter that would send the sensor readings and the GPS position and time readings to a monitoring station via a satellite communication system. Depending on the specific exploratory mission, the sensors could include a thermometer, a barometer, a magnetometer (for studying the terrestrial magnetic field and/or detecting buried meteorites), a subsurface radar system (for measuring ice thickness and/or detecting buried meteorites), and/or one or two diametrically opposed cameras that would take the part of sending two side-looking images out.

In the planned Antarctic field test, a prototype tumbleweed rover was released at a location near the South Pole. Using the global Iridium satellite network to send information about its position, the

rover transmitted temperature, pressure, humidity, and light intensity data to NASA's Jet Propulsion Laboratory. The rover reached speeds of 30 km per hour over the Antarctic ice cap, and traveled at an average speed of about 6 km per hour. The test was designed to confirm the rover's long-term durability in an extremely cold environment, with the goal being eventual use of the device to explore the Martian polar caps and other planets in the solar system. On future Antarctic exploratory missions, tumbleweed rovers might be used to acquire sensor data for studies of global warming, ozone depletion, and impacts of meteorites.

*This work was done by Alberto Behar, Jack Jones, Frank Carsey, and Jaret Matthews of Caltech for NASA's Jet Propulsion Laboratory. Further information is contained in a TSP (see page 1).  
NPO-40499*

---

## Two-Photon Fluorescence Microscope for Microgravity Research

**The benefits of two-photon fluorescence microscopy are realized at reduced cost.**

*John H. Glenn Research Center, Cleveland, Ohio*

A two-photon fluorescence microscope has been developed for the study of biophysical phenomena. Two-photon microscopy is a novel form of laser-based scanning microscopy that enables three-dimensional imaging without many of the problems inherent in confocal microscopy. Unlike one-photon optical microscopy, two-photon microscopy utilizes the simultaneous nonlinear absorption of two near-infrared photons. However, the efficiency of two-photon absorption is much lower than that of one-photon absorption, so an ultra-fast pulsed laser source is typically employed.

On the other hand, the critical energy threshold for two-photon absorption leads

to fluorophore excitation that is intrinsically localized to the focal volume. Consequently, two-photon microscopy enables optical sectioning and confocal performance without the need for a signal-limiting pinhole. In addition, there is a reduction (relative to one-photon optical microscopy) in photon-induced damage because of the longer excitation wavelength. This reduction is especially advantageous for *in vivo* studies. Relative to confocal microscopy, there is also a reduction in background fluorescence, and, because of a reduction in Rayleigh scattering, there is a 4× increase of penetration depth.

The prohibitive cost of a commercial two-photon fluorescence-microscope sys-

tem, as well as a need for modularity, has led to the construction of a custom-built system (see Figure 1). This system includes a coherent mode-locked titanium:sapphire laser emitting 120-fs-duration pulses at a repetition rate of 80 MHz. The pulsed laser has an average output power of 800 mW and a wavelength tuning range of 700 to 980 nm, enabling the excitation of a variety of targeted fluorophores. The output from the laser is attenuated, spatially filtered, and then directed into a confocal scanning head that has been modified to provide for side entry of the laser beam. The laser output coupler has been replaced with a dichroic filter that reflects the longer-wavelength excitation