

# **FULL-SCALE ADVANCED SYSTEMS TESTBED: ENSURING SUCCESS OF ADAPTIVE CONTROL RESEARCH THROUGH PROJECT LIFECYCLE RISK MITIGATION**

Kate M. Pavlock  
Operations Engineer  
NASA Dryden Flight Research Center  
Edwards, California Email: kate.pavlock@nasa.gov

## **1. ABSTRACT**

The National Aeronautics and Space Administration Dryden Flight Research Center (Edwards, California) completed flight-testing of adaptive controls research on the Full-Scale Advanced Systems Testbed (FAST) in January of 2011. The research addressed the technical challenges involved with reducing risk in an increasingly complex and dynamic national airspace. Specific challenges lie within the development of validated, multidisciplinary, integrated aircraft control design tools and techniques that will enable safe flight in the presence of adverse conditions such as structural damage, control surface failures, or aerodynamic upsets. The testbed is an F-18 airplane (McDonnell Douglas, now The Boeing Company, Chicago, Illinois) serving as a full-scale vehicle to test and validate adaptive flight control research, and lends significant confidence to the development, maturation, and acceptance process of incorporating adaptive control laws into follow-on research and ultimately the operational environment. The experimental systems integrated into the Full-Scale Advanced Systems Testbed were designed for flexible yet safe flight-test evaluation and validation and revolve around two major hardware upgrades: the modification of flight control computers and integration of two fourth-generation Airborne Research Test Systems. Flight validation of these systems provided the foundation for Nonlinear Dynamic Inversion and Model Reference Aircraft Control adaptive control law experiments. To ensure success of flight in terms of cost, schedule, and test results, emphasis on risk management was incorporated into the early stages of design and flight-test planning and continued through the execution of each flight-test mission. Specific consideration was made to incorporate safety through hardware and software features, test processes, and training to reduce the human factors impact to safe and successful flight-testing. This paper describes the research configuration, experiment functionality, overall risk mitigations, flight-test approach and results, and lessons learned from the adaptive controls research of the Full-Scale Advanced Systems Testbed.

## **2. NOMENCLATURE**

1553	Mil-Std-1553 data bus
68040	research flight control computer processor
701E	production flight control computer processor
ail	aileron
ARTS IV	Airborne Research Test System, 4th Generation
CAT	Choose-A-Test
cmd	command
DAG	Dial-A-Gain
DDI	Digital Display Indicator
DFRC	Dryden Flight Research Center

DPRAM	dual-port random access memory
FAST	Full-Scaled Advanced Systems Testbed
FCC	flight control computer
FCS	flight control Surface
FDMS	Flight Deflection Measurement System
GTM	ground-test mode
HILS	hardware-in-the-loop simulation
IRAC	Integrated Resilient Aircraft Control
KIAS	Knots Indicated Airspeed
LCD	liquid crystal display
LEF	leading edge flap
MRAC	Model Reference Adaptive Control
NASA	National Aeronautics and Space Administration
NDI	Nonlinear Dynamic Inversion
NWS	Nosewheel Steering
PLA	power lever angle
OBES	On-Board Excitation System
PSFCC	Production Support Flight Control Computer
PVI	pilot-vehicle interface
RFCS	research flight control system
RS-422	twisted pair data transmission American National Standards Institute standard
rud	rudder
SARE	Simple ARTS IV Research Experiment
stab	stabilator
TEF	trailing edge flap

### 3. INTRODUCTION

The National Aeronautics and Space Administration (NASA) Dryden Flight Research Center (DFRC) (Edwards, California) completed adaptive flight control research flight-testing in January 2011 in support of the Integrated Resilient Aircraft Control (IRAC) project. The project aimed to address technical challenges of the NASA Aviation Safety Program involving the development of validated, multidisciplinary, integrated aircraft control design tools and techniques to enable safe flight in the presence of adverse conditions such as structural damage, control surface failures, icing, or aerodynamic upsets. Such adaptive control research ultimately supports the ability to reduce risk in an increasingly complex and dynamic national airspace.

Full-scale flight research is critical to the development, maturation, and acceptance of adaptive control laws for both future research and use in the operational environment; it also provides the capability of piloted evaluations and exploration of unanticipated human-algorithm interactions in flight. To facilitate full-scale testing of IRAC adaptive control technologies, supporting hardware and software was incorporated into the NASA F-18 airplane (McDonnell Douglas, now The Boeing Company, Chicago, Illinois), tail number 853, termed the Full-Scale Advanced Systems Testbed (FAST). The testbed was identified as a principal asset for the anticipated research for three key reasons: 1) the pre- and post-departure characteristics of this airplane are already well understood; 2) the platform has a robust capability to recover from unusual attitudes and departures; and 3) significant research instrumentation has been incorporated into the testbed from previous research flight-testing.

The effort utilized a build-up approach to integration and testing, culminating in the in-flight evaluation of a Model Reference Adaptive Controller (MRAC) designed to evaluate whether a

very simple adaptive control algorithm can be adequately tested using traditional flight qualification methods and still serve as a useful level of safety enhancement to flight control.

## **4. RESEARCH CONFIGURATION**

To allow for flexible yet safe flight-test evaluation and validation of modern adaptive control technologies, several experimental systems were integrated into FAST. Two major hardware upgrades included the modification of flight control computers (FCCs) and the integration of two dual-redundant, fourth-generation Airborne Research Test Systems (ARTS IV).

### **4.1. Flight control computer modifications**

Unmodified FCCs are quad-redundant and incorporate 701E processors.<sup>1</sup> Previous Active Aeroelastic Wing (AAW)<sup>2</sup> project modifications incorporated a Motorola 68040 research processor (Motorola Solutions, Inc., Schaumburg, Illinois) into each channel of the FCCs and dual-port random access memory (DPRAM) and software interfacing between the 701E and 68040. The 68040 hardware and software combination comprises the research flight control system (RFCS) and the modified FCCs are termed Production Support FCCs (PSFCCs). The RFCS can perform fading between experiments and production control laws, execute replicated F-18 production control laws, monitor research disengage limits, pass state data and replication control law commands to the ARTS IV units, receive experimental control law commands from the ARTS IV units, and provide actuator commands and RFCS state information to an instrumentation downlink.

### **4.2. Airborne Research Test System IV**

Two dual-redundant ARTS IV units installed in the front fuselage of the FAST airplane are designed to provide the flexibility needed for quick software development, testing, integration, and validation. The units augment the RFCS by providing external input/output, internal memory, and additional processing power. Operating in parallel, the units communicate with five external systems: 1) RFCS 68040 software; 2) instrumentation; 3) embedded global positioning system (GPS) and inertial navigation system (EGI); 4) pilot-vehicle interface (PVI); and 5) payloads. The general research interface architecture interfacing with the RFCS and ARTS IV systems is shown in figure 1.

Experimental software hosted in the RFCS and ARTS IV computers has the capability to exercise full control over aircraft flight control surfaces and throttle levers. Up to eight experiments may run simultaneously. Only one out of the potential eight is designated as the controlling experiment and can command the aircraft actuators. Communication between experiments, however, is set up to allow inputs to the controlling experiment as needed.

The RFCS and ARTS IV research hardware and software upgrades also tie into extensive pre-established research instrumentation that includes loads, dynamics, and aerodynamic parameters that are available to the instrumentation downlink for real-time or post-flight analysis.

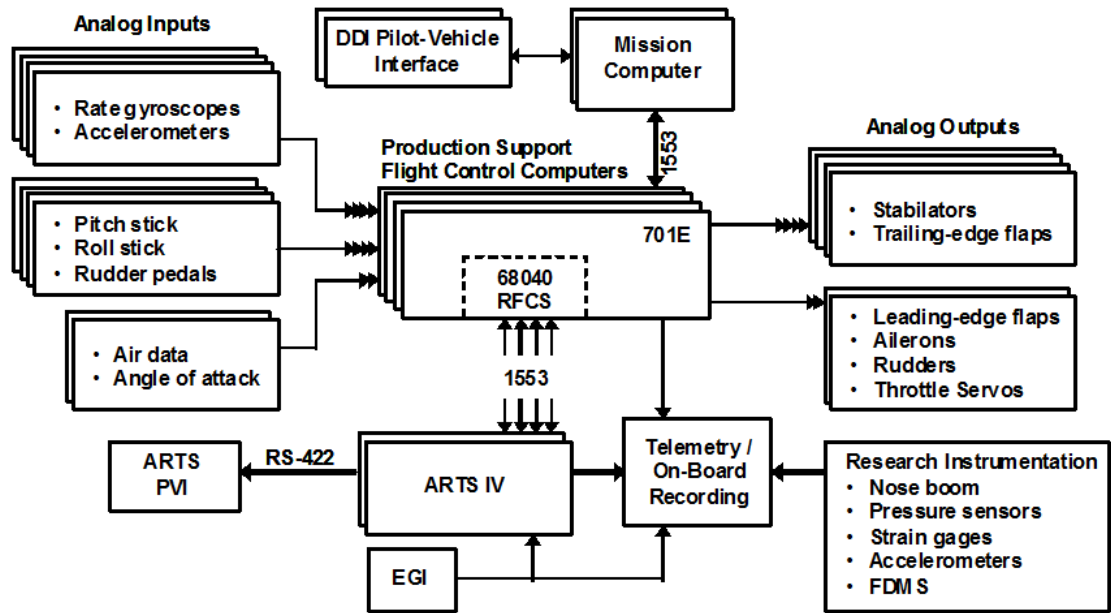

Figure 1. The Full-Scale Advanced System Testbed research flight control system interface architecture.

Further design features include a PVI installed below the Up Front Controls in the cockpit that provides visual feedback to the pilot by means of a 2-by-20-character backlit liquid crystal display (LCD) as shown in figure 2. The PVI displays ARTS IV interpretations of proper experiment selection inputs, experiment modes, system status, and ARTS IV health messages.

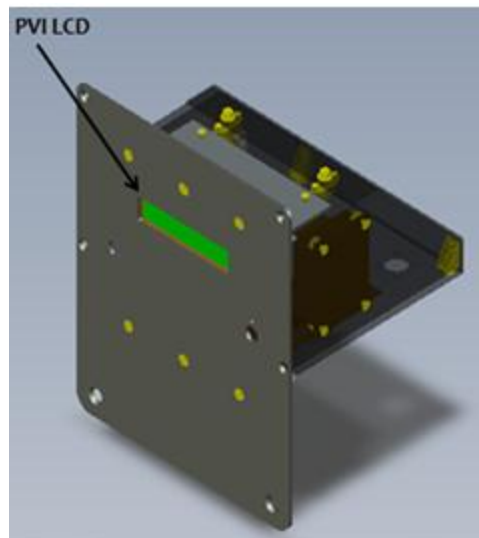

Figure 2. The pilot vehicle interface unit with liquid crystal display.

## 5. EXPERIMENT MODES, STATES, AND EXPERIMENT CAPABILITIES

Several experiment modes are available that further facilitate flexible yet safe flight-test evaluation of adaptive control technologies. A ground-test mode (GTM) provides the means for functional systems verification testing of the RFCS and ARTS IV units before flight. In flight,

three experimental modes affect the way in which RFCS replication control law commands are combined with commands from the ARTS IV units. Once an experimental mode is selected, RFCS states provide a safe mechanism for transitioning between production and research control laws, and provide situational awareness of the operational status of the experimental mode to the pilot. Different selectable experiment capabilities are available depending on the experiment mode. Experiment capabilities are selected in a predefined approach that incorporates several checks and balances for increased risk mitigation.

### 5.1. Experiment modes

The research control laws can run in three research experiment modes: RFCS Primary, RFCS/ARTS mixed mode, and ARTS Primary. In RFCS Primary mode, F-18 production control laws replicated within the RFCS provide surface and throttle commands to the 701E; all ARTS IV commands are ignored. In the RFCS/ARTS mixed mode, surface and throttle commands from the RFCS replication control laws are merged with commands from the ARTS IV and sent to the 701E. In ARTS Primary mode, the ARTS IV performs all control law calculations internally and ARTS IV control surface and throttle commands replace RFCS control law commands. In all modes, however, the RFCS safety monitors all commands.

### 5.2. States

There are three RFCS states which ultimately describe the transfer of control between the 701E and the RFCS: 1) disengaged; 2) armed; and 3) engaged. Experiment selection occurs in the disengaged state while the 701E maintains control over the primary flight control system and no replication control law commands are generated by the RFCS. A research-modified flight control surface (FCS) page shows the traditional control surface health status and RFCS state data (figure 3). This page supplements the standard F-18 FCS page and integrated PVI for additional aircraft and research state information relay to the pilot.

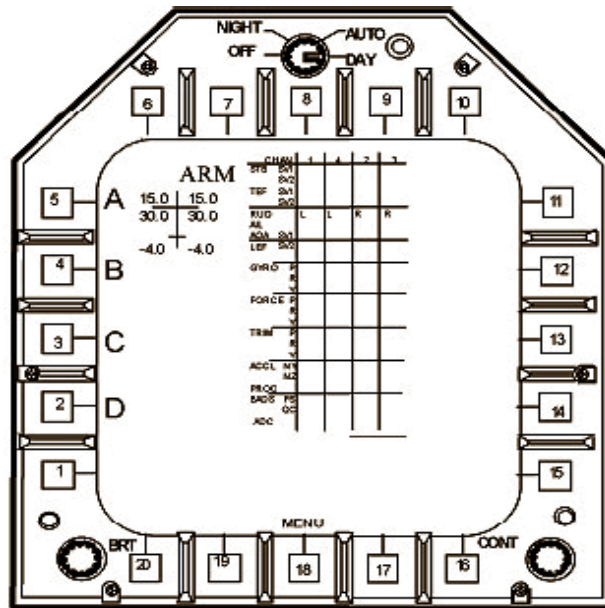

Figure 3. Depiction of Digital Display Indicator showing research flight control system page.

The button representing “A” on the Digital Display Indicator (DDI) is reserved for arming the RFCS. In the armed state, the 68040 processor begins to generate replication control law

commands while the 701E retains control over the primary flight control system. Upon arming, the “ARM” indication is displayed on the research FCS page. If an incorrect experiment selection sequence is entered, the software will not allow subsequent arming of the RFCS. A single depression of the Nosewheel Steering (NWS) button from the armed state is required to engage the research. In the engaged state, command of aircraft control is handed over from the 701E to the RFCS and the “ARM” indication on the research FCS page is replaced with “1234.”

### 5.3. Experiment capabilities and experiment selection

Each experiment mode houses selectable experiment capabilities that support RFCS and ARTS IV checkout flights. Several of these capabilities reside in the RFCS and include replicated F-18 production control laws. The replication control laws were used to conduct back-to-back comparisons of flight dynamics with the 701E to ensure that the RFCS did not introduce any undesirable effects. Use of an additional system called the On-Board Excitation System (OBES) added programmed digital signals to the control system actuator commands for excitation of aircraft dynamics. Excitation maneuvers for OBES include both collective and differential doublets of individual control surfaces, frequency sweeps of rudders, flaps, and throttles, and doublets injected into the pilot’s stick, pedal, and throttle inceptor paths. Five combinations of simulated control surface failures are also programmed into the RFCS with the addition of four varying levels of simulated damaged wing scenarios.<sup>3</sup> Each was designed to present varying levels of challenging yet controllable failure scenarios. Selected simulated failures and OBES maneuvers were evaluated in RFCS Primary mode to validate proper baseline RFCS-701E command logic.

A Simulink® (The MathWorks, Natick, Massachusetts) generated Simple ARTS IV Research Experiment (SARE) was used to verify operation of the RFCS/ARTS mixed mode. The purpose of the SARE was to either inject OBES maneuvers into the pilot command path to the RFCS replication control laws or the surface command path from the RFCS replication control laws. Testing of the SARE signified the first in-flight execution of an ARTS IV controlling experiment and validated ARTS IV capabilities.

The ARTS Primary mode was validated using ARTS IV Pass-Thru experiments. The Pass-Thru experiments receive control surface commands generated within the RFCS but not initially sent to the 701E. Instead, the ARTS IV passes the commands back to the RFCS unaltered, where they are loaded into the DPRAM and read by the 701E.

The experiment capabilities residing in the RFCS or ARTS IV units are selected by the pilot through Dial-a-Gain (DAG) and Choose-a-Test (CAT) entries using the standard F-18 DDIs in the cockpit. The DDI buttons representing “B,” “C,” and “D” are used to select a particular experiment capability correlating to predefined DAG (0-26) or CAT (0-26) number pair sequences stored in memory. Table 1 outlines the DAG/CAT flight configurations available for each experimental mode.

Experimental Mode	DAG
RFCS Primary	0
RFCS/ARTS Mode	1-13
ARTS Primary	14 – 26

Table 1(a). The Dial-A-Gain flight configurations.

	DAG	CAT	RFCS Research Experiment
No Failures	Any	0	No OBES, no simulated failures
Simulated Failures: - RFCS Primary - RFCS/ARTS Mode - ARTS Primary	Any	1	Right Stab, Left/Right Aileron failed at 0° offset
	Any	2	Left/Right Stab failed at 0° offset
	Any	3	Left/Right Stab, Left/Right Aileron failed at 0° offset
	Any	4	Left/Right Stab, Left/Right Ail, Left/Right Rudder, Differential LEF and TEF failed at 0° offset
	Any	5	Collective LEF/TEF schedule multiplier 1.0, Right LEF/TEF failed at 0° absolute
	Any	6	Collective LEF/TEF schedule multiplier 2.0, Right LEF/TEF failed at 0° absolute
	Any	7	Collective LEF/TEF schedule multiplier 4.0, Right LEF/TEF failed at 0° absolute
	Any	8	Collective LEF/TEF schedule multiplier 8.0, Right LEF/TEF failed at 0° absolute
	Any	9	Right Stab failed at 0° absolute
RFCS OBES: - RFCS Primary - RFCS/ARTS Mode - ARTS Primary	Any	10	OBES – Frequency sweep, differential Rud
	Any	11	OBES – Frequency sweep, differential TEF
	Any	12	OBES – Frequency sweep, collective PLA
	Any	13	OBES – Frequency sweep, differential PLA
	Any	14	OBES – Collective surface doublets
	Any	15	OBES – Differential surface doublets
ARTS OBES: - RFCS/ARTS Mode	4 - 8	16	SARE – High amplitude inceptor doublets
	4 - 8	17	SARE – Medium amplitude inceptor doublets
	4 - 8	18	SARE – Low amplitude inceptor doublets
ARTS Spares	Any	19 – 26	N/A

Table 1(b). The Choose-A-Test flight configurations.

## 6. RISK MITIGATION TECHNIQUES

Up-front and continued risk management is a key component to safe and successful flight-testing. Risk management involves the identification of risks, assessment of their impact, and implementation of tailored mitigations to minimize, monitor, or eliminate the credibility of risk. Effective risk management can control the probability or impact, or both, to test successes. Common risk management techniques include bounding risk through design features, utilizing a systematic build-up approach, incorporating thoroughly documented processes and procedures, and establishing a safety-focused test team. Several key risk mitigations implemented for the IRAC project are discussed below.

### 6.1. Bounding risk

The foundational approach to risk mitigation for the project was to reduce or eliminate unnecessary risk. This was achieved through the determination to conduct testing while in RFCS armed or engaged states within the Class B envelope depicted in figure 4. The phrase “Class B” refers to a predetermined flight envelope associated with a NASA DFRC flight qualification level of software that is considered mission critical (Level B) rather than safety critical (Level A).<sup>3</sup> Analysis showed that test points within the Class B envelope would not produce transients exceeding aircraft load limits should maximum rate deflections of all control surfaces to their position limits, known as a “hard-over,” occur. Operating within this flight envelope minimizes structural concerns while providing sufficient altitude for recovery from unusual attitudes. Therefore, operating within this flight envelope bounded risk to an acceptable level.

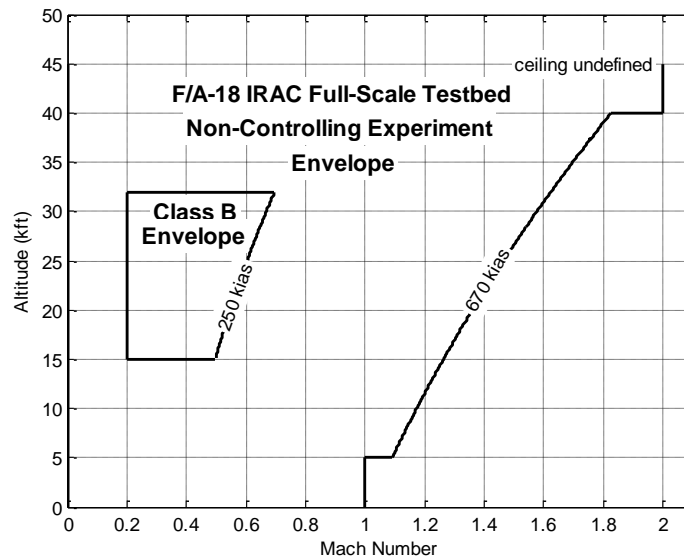

Figure 4. The Class B flight envelope and the Integrated Resilient Aircraft Control project flight conditions.

Another technique used to bound risk and reduce single-point failures is to design-in safety mitigations. Several design features were incorporated into the research architecture to alleviate or significantly reduce pilot and mission control personnel workload during testing and improve situational awareness for increased safety and higher data quality acquisition. For example, the Class B envelope was enforced automatically by RFCS software disengage limits. Although these limits were also monitored in the mission control center in real time, these software-enforced limits reduced dependency on pilot reaction time to disengage the system if a failure occurred.

Another important safety feature incorporated into the design of the research software architecture is the three-stage RFCS state transition to engagement described above. This offers an additional measure of safety by requiring two distinct inputs by the pilot to completely transition control of the flight control system to the RFCS. Furthermore, the system is designed to register disengagement whenever the pilot executes any one of several manual disengagement options, including depressing the Autopilot Disengage Switch, positioning the flap switch to full or half, or pulling any single FCS breaker, to name a few. By incorporating several manual disengagement options the project pilot or project team is always the ultimate controller of the research while eliminating single-point failures.

The ARTS IV software also offers an additional built-in risk mitigation feature: all output signal checks apply a DFRC-designed “floating limiter” on commands to limit the potential for a hard-over. Within the floating limiter, shown in figure 5, a maximum drift rate or rate of change is designed into the limiter. When a signal exceeds its specified maximum drift rate, the floating limiter boundary is hit and this signal is rate-limited, thus preventing a hard-over.



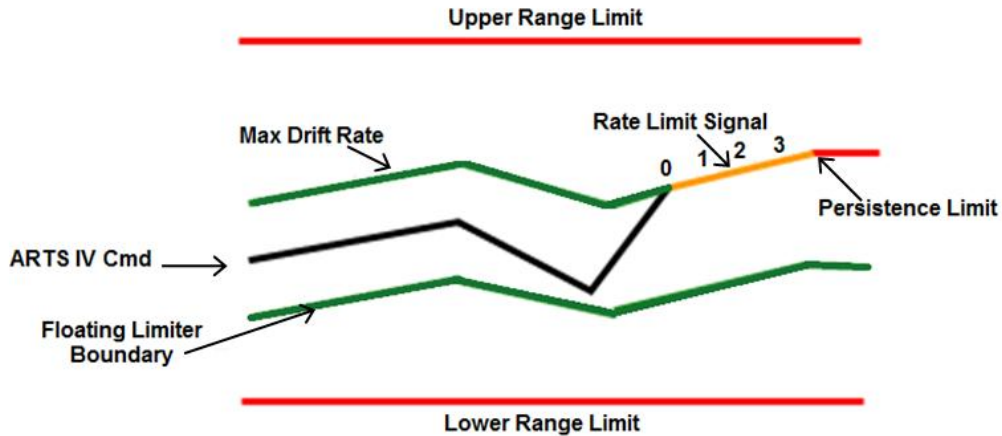

Figure 5. The Airborne Research Test System, 4th Generation, floating limiter.

Despite the benefits of up-front risk mitigations their full potential may not be achieved if thorough end-to-end requirements supporting final design decisions are not properly scoped. For example, the PVI LCD was chosen without pilot input prior to procurement. The display proved to be limited in available character spacing to display all ARTS IV desired status information to the pilots. This resulted in abbreviated character representation (figure 6). In some instances, desired display data had to be altogether excluded, such as RFCS auto-disengagement flags. Furthermore, available installation locations were limited to forward of the control stick and below the DDIs in the cockpit. This location combined with sun glare made the PVI unreadable during some flight maneuvers. Flight test evaluations prior to final installation to evaluate configuration and flight environment impacts would have provided helpful design upgrades to produce a more universally applicable display. For example, the display could have incorporated an angled display for a clearer screen view.

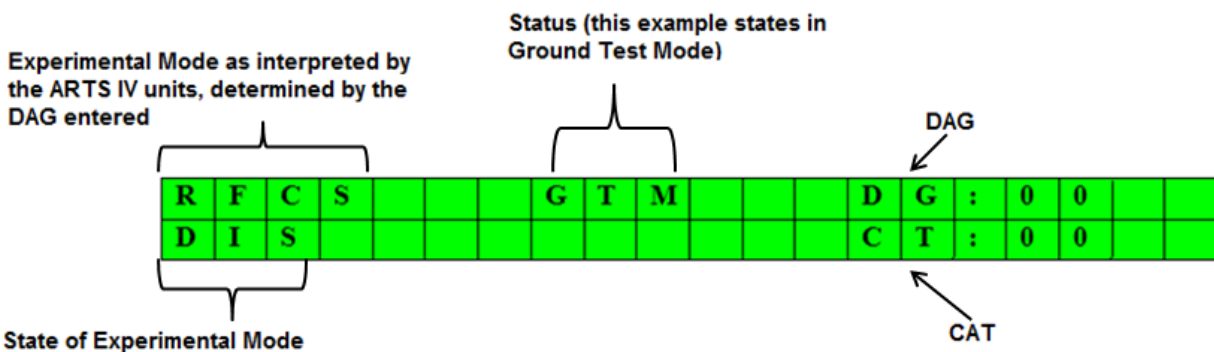

Figure 6. Example of pilot vehicle interface liquid crystal display character design

Flight test card development and test point sequencing served as another example of built-in risk mitigation, albeit through procedure documentation rather than design. Several verification checkpoints were incorporated into the flight test cards at key test point execution stages to ensure proper situational awareness of the state and operation of the research for both the pilot and mission control center personnel. Verification checkpoints included approvals to proceed from system level engineers to the flight director with hand-off to the mission controller and ultimately the pilot. In addition, DDI entries for experiment capability selection and state

transitions, and NWS inputs for RFCS engagement were performed with step-by-step verification checkpoints as described above to augment the limited situational awareness provided by the PVI display. A secondary benefit to this approach is that test card execution points and checkpoints provided an expected cadence representing efficient flight-testing. This served as a metric to evaluate team situational awareness and readiness. For example, it was observed that after unexpected research disengagements, whether manual or automatic, the cadence was affected and more prompting to control room personnel or the pilot was needed. These cues may have been indicative of a lack of readiness to proceed and serve as an evaluation point for a flight-test pause to refocus the test team. Specific recommendation is made to incorporate cadence metrics, when appropriate, to obtain human factor cues that can indicate stress risers which may affect flight-test safety or efficiency.

## **6.2. Build-up approach to integration and testing**

Component and system-level testing provides valuable verification of proper functionality that lends considerable confidence to success in the final flight-test environment. Several testing efforts were conducted both at outside agency facilities responsible for the research modifications as well as at DFRC. After traditional component and system level acceptance and electromagnetic compatibility/interference testing was completed on the research components, emphasis was placed on simulation testing.

The Boeing Company headed FCC modifications and RFCS integration with the bulk of RFCS component-level testing occurring at their St. Louis, Missouri facility. Hardware-in-the-loop Simulation (HILS) testing preceded combined RFCS-ARTS IV integration testing at Boeing to verify the mechanization of the RFCS in an integrated closed-loop environment with a six-degrees-of-freedom aircraft simulation. In addition, Boeing HILS testing was performed by NASA DFRC project pilots to evaluate flying qualities with mission-representational pilot command inputs. This participation also provided flight familiarization for the project pilots and the opportunity for researchers to obtain early experiment performance feedback. Additional DFRC hardware and software-configurable simulation testing included duplicated Boeing HILS test cases, RFCS flight operating envelope limit checks, and back-to-back RFCS and F-18 production control law comparisons. To validate the simulation, a series of time history check cases were generated for each simulation release and over-plotted against the previous release to confirm that no unexpected changes to the dynamics were introduced into the system.

The available resource of the DFRC simulation prompted evaluation to assess its applicability to serve as a build-up approach tool for the implementation of additional safety mitigations. Evaluation of this potential culminated in the implantation of *pre-mission* rules that outlined the project approach toward verifying the acceptability of proposed test points for a given research mission prior to flight by means of specific simulation testing. Such rules mandated the tracking and verification of test card points and DAG/CAT functionality in the piloted simulation prior to flight. Furthermore, these rules required project pilot evaluation rather than engineering to aid in pilot familiarity of the test approach outlined in the test cards and to gain a perspective on expected transients given typical pilot inputs. Traditional mission rules are implemented to mitigate identified research hazards with respect to adverse human, asset, or mission impacts during flight-testing. The DFRC simulation provided an opportunity to incorporate additional build-up approach stepping stones and enhanced safety oversight in support of successful flight testing beyond traditional mitigations.

Further use of the DFRC simulation as a build-up approach tool involved training for non-project specific pilots whose experiment evaluation feedback aided in obtaining well-rounded test results from a variable-gain test pilot pool. Such training incorporated discipline and mission controller participation to exercise expected test point cadence and prompting. Additional required familiarization included participation as chase aircraft pilot to hear real-time flight-test prompts and visually assess expected transients. The benefit to this approach was realized during HILS testing as a low-gain pilot discovered an adaptive controller problem that neither the other pilots nor research engineers had discovered. It was found that with a constant non-zero stick input and no roll motion, the MRAC gains tended to saturate. This destabilized the roll axis and resulted in a pilot-induced oscillation in that axis. Although a high-pass filter for lateral stick commands could have been incorporated into the controller logic, the issue was mitigated through gain parameter monitoring in the mission control center in real time for gain parameter saturation and contact lateral stick position. If either were detected, a “knock-it-off” call was issued to the pilot to cease test point execution and manually disengaged out of the RFCS.

Despite the recognized benefits of the DFRC simulation application, a shortfall of the approach was revealed during flight-testing. Often test point evaluation in the simulation omitted traditional in-flight test point set-up techniques or evaluation much outside the boundaries of the test point. Due to this reduced scope in simulation testing, several nuisances were found such as what were described to be “pitch bobbles” while setting up for air-to-air tracking task maneuvers during MRAC flight testing. Although this finding was determined to be a nuisance, it highlighted the potential for unrealized safety problems if simulation testing is too narrowly scoped. When appropriate, test planning should incorporate safety-of-flight verification of control laws beyond the intended flight-test point to include test point set-up maneuvers in preparation for unanticipated human algorithm interactions.

### **6.3. Team cohesion**

Team cohesion promotes effective communication and improves planning efforts that are essential to cultivating a safety-conscious test team. The project team focused on thoroughly vetted and well-documented policies and procedures to promote group cohesion. For example, a project contingency management plan was documented and rehearsed using project team members and project pilots during a combined system test to increase mission control center familiarity and reinforce the need for quick, rational decisions in a high-stress environment. Building up to this demonstration, project personnel participated in Crew Resource Management training. All efforts culminated in a documented control room training plan outlining the roles and responsibilities of the project team members in the mission control center. The plan described proper communication to identify inoperative mission parameters, circumstances requiring an immediate return to base, familiarity with incident response checklists, training requirements for discipline backup personnel, display change rules, and interdisciplinary communications. These efforts instilled project personnel with confidence and group trust, and reinforced a safety-first test team culture. Clearly communicated and documented policies and procedures also provide ease of flexibility to adapt to changing flight test goals. For example, implemented mission rules were incorporated into a project document that included project implementation rationale and the criteria for removing the rule. This practice provided a clear metric for determining which rules were applicable to a given flight-test regime, rather than carrying unnecessary limitations that could impact data quality or induce needless interruptions to test point execution.

## 7. FLIGHT-TEST APPROACH AND RESULTS

Implementation of a build-up approach to flight-testing, as with integration and test, is useful in the identification of potential unexpected hazards or threats to the technical integrity of the research under test. Each step progressively brings the outcome into focus with a clarity that is not possible from the beginning. A general build-up approach toward increased research complexity was implemented to verify proper component and system functionality, manage risk, and allow the project team to gain experience with test procedures and the general functionality of the research systems. An aggressive flight schedule, shown in table 2, was attainable because of the design of the ARTS IV and RFCS architecture, aircraft robustness especially within the Class B envelope, team cohesion, and documented processes.

Date	Test Type
Nov 2009	Instrumentation checkout flight
Dec 2009	Mission Computer configuration checkout flight
Apr 2010	RFCS ONLY (OBES & Simulated Failures) flight
Apr 2010	RFCS ONLY (Simulated Failures & Throttles Only) flight
Apr 2010	RFCS ONLY flight
July 2010	RFCS/ARTS Combined Systems ground test
Aug – Sept 2010	RFCS/ARTS flight + 1 repeat flight
Sept – Oct 2010	NDI Combined Systems ground test + 5 flights
Dec – Jan 2011	MRAC Combined Systems ground test + 11 flights

Table 2. Verification and Validation schedule of the Full-Scale Advanced Systems Testbed

### 7.1. Baseline checkouts

Several baseline checkout flights in the upgraded instrumentation and 701E configuration were accomplished in late 2009. When the baseline checkout flights were completed, unmodified FCCs were swapped for the PSFCCs that incorporated the RFCS.

### 7.2. Research Flight Control System and Airborne Research Test System IV checkouts

Subsequent research validation flights followed the build-up approach as the RFCS Primary, RFCS/ARTS mixed mode, and ARTS Primary modes were validated sequentially. Prior to the start of RFCS Primary flights, however, a combined systems test was conducted to serve as an end-to-end check between the aircraft research systems and the mission control center. This test verified proper research and mission control center display functionality as well as verified no adverse electromagnetic compatibility or interference during external or internal aircraft power. As a stepping-stone to each flight, a GTM preflight check was performed. The GTM check supplemented the standard F-18 pre-taxi checks and permitted research engagement when weight-on-wheels and throttles idle were “true.” The GTM checks exercise the command and response communication between the mission control center and the pilot, animate mission- or safety-critical parameters on mission control center displays, and confirm proper arm, engage, and disengagement operation of the RFCS prior to takeoff. Initial RFCS Primary in-flight checks repeated validation of arming (including failed arming attempts), disarming, engagement, and both manual and automatic disengagement attempts specific to the RFCS. A subset of test points performed in the Boeing and Dryden HILS were flown with the intention of confirming the accuracy of the HILS results. Flight dynamic maneuvers followed functionality checks within the same flight and included typical maneuvers such as doublets, pitch and bank

captures, steady-heading sideslips, 360-degree rolls, 2-g loaded rolls, and 2.5-g wind-up turns. Back-to-back comparisons of the flight dynamics between the 701E control laws and the RFCS control laws were performed to confirm that the RFCS control laws replicated the production control laws in the 701E within expectations. Further testing included a subset of OBES maneuvers and simulated failures programmed into the RFCS. A total of three RFCS Primary checkout flights were performed in April of 2010.

After the RFCS Primary mode in-flight validation flights were completed, the integration and ground-testing of the ARTS IV units, PVI, and associated instrumentation system commenced using the RFCS/ARTS mixed mode and ARTS Primary research modes. Since integration of the additional research hardware required a break in the previously-documented configuration, an additional combined systems test was conducted. Post-flight evaluation of the combined systems test data revealed that a stabilator hard-over occurred upon disengagement of the RFCS/ARTS mixed mode as the 701E commanded the horizontal stabilator to its trailing-edge-down limit. Upon re-arming and engaging, the RFCS and ARTS IV software retained the trailing-edge-down command limit to the stabilators. This finding prompted immediate flight grounding and additional testing until the behavior could be better understood. The additional testing showed that the surface positions were commanded based on the design of the forward-loop integrator in the pitch axis of the 701E control laws as well as the compensation required during engagement and disengagement of the RFCS control laws. The project team determined that engaging RFCS in GTM may cause the 701E integrator to be pre-seeded with an improper value upon RFCS disengagement. The effect was deemed a “nuisance” when in GTM and not a safety-of-flight problem within the Class B envelope. The combined systems test finding served as a role-model event that highlighted attention to detail, non-complacency, willingness to identify potential safety concerns, and a dedication to resolving problems effectively among project team members. The event ultimately stressed the importance of training, team cohesion, and adherence to policies and procedures.

RFCS/ARTS mixed mode and ARTS Primary mode research flights involved similar pre-taxi and in-flight arming or disarming, and engage or disengage checks as were performed during RFCS Primary checkout flights. Subsequent testing included checkout of the PVI as well as SARE experiments specific to the ARTS IV units. The ARTS IV Pass-Thru experiment capability was tested in the ARTS Primary mode. This experiment validated ARTS IV operation, timing, failure annunciation, and integration of the ARTS IV units with the 701E-RFCS system. Similar to the RFCS Primary mode, flight dynamic maneuvers were used to evaluate back-to-back comparisons of the Pass-Thru experiment and RFCS control laws to ensure that ARTS IV processing and communication with RFCS did not introduce any excessive time delay. During ARTS Primary mode experiment capability testing, candidate handling qualities tasks were developed to better assess future experiments. Handling qualities tasks included wingtip formation flight, in-trail formation flight, and 2-g air-to-air tracking tasks. At this stage, formation tasks were evaluated exclusively using 701E production control laws; however, 2-g air-to-air tracking tasks were performed in both 701E and RFCS Primary mode.

Checkout of the RFCS/ARTS mixed mode and ARTS Primary experimental modes were completed after two flights in August and September of 2010. Flight data showed that the RFCS and ARTS IV software behaved as expected with only minor discrepancies noted. Overall, results showed good flight-to-simulation match. Completion of the research mode flight tests laid the groundwork for follow-on flight-testing of Nonlinear Dynamic Inversion (NDI) and MRAC controllers.

### **7.3. Nonlinear Dynamic Inversion controller**

Several standard flight control designs are largely linear control laws with integrated nonlinear elements to account for real-world vehicle dynamics and handling qualities requirements. Nonlinear Dynamic Inversion is a technique for control law design based on feedback linearization to achieve desired dynamic response characteristics.<sup>4</sup>

An NDI control law was loaded into the ARTS IV system for flight-test validation as the baseline control law to enable follow-on MRAC flight-testing and validation. The primary goals of NDI flight-testing were to demonstrate that the NDI control law was well suited to support subsequent MRAC flights, demonstrate the RFCS and ARTS IV capability in ARTS Primary mode with a closed-loop control law, and explore the accuracy of the current prediction tools for the effectiveness of non-conventional control surface mixing.<sup>4</sup>

As with previous hardware or software configuration changes, ground verification and validation tests of the NDI control law were conducted. Ground-test results showed good software and hardware correlations. This lent strong support for continued software simulation usage for robustness check cases. In addition, sufficient stability margins were noted within the Class B envelope for all robustness cases.

The bulk of the flight-testing was intended to show that the NDI controller behaves the same way in flight as in the simulation and to highlight any handling qualities deficiencies that may adversely affect the MRAC research.<sup>4</sup> Typical test maneuvers were employed at multiple flight conditions within the Class B envelope and included maneuvers such as piloted frequency sweeps, speed brake deployment, 3-axis doublets, pitch and bank captures, steady-heading side slips, 360-degree rolls, 2-g loaded rolls, 2.5-g wind-up turns, and disengagement transient testing. Furthermore, experiment configurations were selected to show that the NDI control law was robust enough to remain controllable for a variety of simulated failure conditions such as pitch axis control effectiveness failures, failures that result in cross-axis coupling, and failures that result in undesirable open-loop dynamics.<sup>4</sup> Tracking performance and handling qualities tasks were also performed at nominal conditions to verify that the NDI was an adequate baseline controller for future MRAC testing. In-trail formation flight tasks and 2-g air-to-air tracking tasks were performed as previously described for both gross acquisition and fine tracking. Tracking task performance was evaluated by the pilots using Cooper-Harper and pilot-induced oscillation rating scales.<sup>5</sup>

Five NDI checkout flights throughout September and October of 2010 were completed with the participation of three project pilots. Overall, flight-test results verified that the NDI control law had good characteristics in a range of flight conditions throughout the Class B envelope.<sup>6</sup> General NDI behavior showed equivalent baseline control law handling qualities aside from minor deficiencies such as heavier stick forces.<sup>6</sup> The success of the baseline NDI controller gave the “green light” to proceed with in-flight demonstration of the strengths and weaknesses of a simple “textbook” MRAC.

### **7.4. Model Reference Adaptive Controller**

The MRAC experiment was developed to further the acceptance of adaptive controls as a means for improving the safety of future aircraft designs in the event of damage or failures of onboard systems. Conventional methods used for verification and validation testing of flight controls software rely upon predictable responses to test scenarios and are ensured by control gains that are either fixed or scheduled via a predefined lookup table or function. Adaptive flight

controls incorporate time-varying gains, however, whose values are less easy to predict and which impose difficulty in flight qualification to a safety-critical level. In response to this difficulty, the MRAC experiment was designed to evaluate whether a very simple adaptive control algorithm can be adequately tested using traditional flight qualification methods and still serve as a useful level of safety enhancement to flight control.

The MRAC contains three modes of varying levels of complexity.<sup>7</sup> The simplest control mode (sMRAC) has a single adaptive gain in each of the pitch and roll axes. The second control mode (onMRAC) retains the same number of adaptive gains while introducing additional complexity into the algorithm that adjusts the values of the gains in response to undesirable aircraft dynamics. The third control mode (onMRAC+) adds a second adaptive gain in each axis to account for failures or damage scenarios that exhibit undesirable coupling between the axes. Each controller mode was evaluated against a suite of simulated failures, ranging from changes to the aircraft's pitch and roll damping to failures that introduced significant coupling between the axes. Flight-test maneuvers and handling qualities evaluations were also performed with tasks similar to the NDI flight-test regime across five pilots and ten research flights.<sup>3</sup>

Challenges were realized that influenced result consistency despite the benefits of previously well-defined handling qualities tasks, test point reordering to reduce anticipated responses, and pilot practice of expected maneuvers. For example, handling quality and nuisance scale ratings from pilot feedback showed a noticeable disparity between the ability of some pilots to adapt to simulated failures. The nuisance scale was similar in scope to the Cooper-Harper and pilot-induced oscillation scales in that it required pilot feedback ratings using a "yes-or-no" flow diagram structure. The purpose of the scale was to determine whether the MRAC induced any noticeable annoyances in its baseline, healthy-aircraft configuration. In some cases, the same simulated failure was rated as either a "major" or "minor" deficiency, depending on the pilot. Although five pilots varying from high-gain (aggressive) to low-gain (smooth and steady) in their pilot-input technique supported flight test activity, test result consistency could have been improved with a larger pilot evaluation group.

Overall, MRAC full-scale flight-testing showed that increased complexity improved aircraft dynamics for simulated failures and restored performance similar to the un-failed aircraft. An accepted handling qualities criterion for fixed-wing aircraft does not exist; however, based on metrics provided by United States Air Force Test Pilot for fixed-wing aircraft, the onMRAC+ controller had the largest reduction in coupling and was rated the same as the un-failed aircraft.<sup>8</sup> Despite this improvement, however, increased complexity also showed an increase in adverse impact to pilot performance.<sup>7</sup> This illustrates the importance of piloted, full-scale flight-testing to both validate predictions and identify unexpected tendencies. Fixes to correct these adverse interactions have been identified, but are not currently planned for flight-testing. More details of the MRAC flight-test results are described in references 7 and 9. In general, MRAC flight-testing showed that increased complexity improved aircraft dynamics for simulated failures and restored performance similar to the un-failed airplane.

## **8. LESSONS LEARNED**

Many lessons learned can be taken from the success of the IRAC project which are indiscriminant to experiment types and are therefore beneficial to the overall flight-test community:

1. Involve all project members as early as possible to bridge research requirement expectations among team members.

2. Designed-in safety features can significantly reduce human factor effects on flight-test safety.
3. Human factors cues are beneficial in highlighting reduced safety conditions due to stress factors or reduced situational awareness.
4. A thoroughly documented control room training plan can be instrumental in ensuring continued situational awareness, consistency of culture, and well-understood roles and responsibilities no matter how experienced the test team.
5. Expand simulation testing beyond specific test points to uncover potential safety impacts to flight due to unanticipated human-algorithm interactions during test point set-up maneuvers.
6. A wide range of test pilots with varying stick input techniques is highly desired to better vet-out controller compensation responses.
7. Perform test point simulation testing as comparable to flight-test techniques as possible to uncover unanticipated technique effects to handling qualities.

## **9. CONCLUSION**

Ultimately, the Integrated Resilient Aircraft Control adaptive flight controls project contributed to the relatively small set of adaptive control flight data available to the flight-test community. Such data provide additional aid to future control designers and their selection of the appropriate level of complexity for their application. Furthermore, the flight-test data provide a better understanding of potential interactions between pilots and adaptive systems. The validated and matured research systems and subsequent experiment development process have longstanding application in facilitating future project success as well as cross-program and cross-platform follow-on projects such as lightweight flexible structures. The rapid concept-to-flight tempo with minimal mission success impacts and lack of safety issues was significantly supported by the incorporation of a variety of risk mitigation techniques into the life of the project and by making a safety-of-flight mindset common culture within the project team. Lessons learned may offer improved safety involving further flight-testing of adaptive control laws.

## **10. REFERENCES**

1. Carter, J.F., "Production Support Flight Control Computers: Research Capability for F/A-18 Aircraft at Dryden Flight Research Center," NASA/TM-97-206233, Oct 1997.
2. Clarke, Robert, Michael J. Allen, Ryan P. Dibley, Joseph Gera, John Hodgkinson, "Flight Test of the F/A-18 Active Aeroelastic Wing Airplane," AIAA-2005-6316, 2005.
3. Hanson, C., "Capability Description for NASA's F/A-18 TN 853 as a Testbed for the Integrated Resilient Aircraft Control Project," DFRC-IRAC-CAP-002, January 28, 2009.
4. Miller, C. J., "Nonlinear Dynamic Inversion Baseline Control Law: Architecture and Performance Predictions," AIAA Conference, 2011 (not yet published).
5. Cooper, G.E. and Harper, R. P., "The Use of Pilot Rating in the Evaluation of Aircraft Handling Qualities," NASA TN D-5153, April 1969.



6. Miller, C. J., Nonlinear Dynamic Inversion Baseline Control Law: Flight Test Results, AIAA GNC August 2011, AIAA Conference, 2011 (not yet published).
7. Hanson, C., Johnson, M., Schaefer, J., Nguyen, N., "Handling Qualities Evaluations of Low Complexity Model Reference Adaptive Controllers for Reduced Pitch and Roll Damping Scenarios" AIAA Guidance, Navigation and Control Conference, Portland, OR, Aug. 2011 (not yet published).
8. D. Fields, D. Marten, G. Di Loreto, R. Koo, J. Lemery, K. Ryan, "Limited Handling Qualities Evaluation of Inter-axis Control Coupling (Project Icarus)," AFFTC-TIM-10-03, June 2010.
9. Schaefer, J., Hanson, C., Johnson, M. and Nguyen, N., "Handling Qualities of Model Reference Adaptive Controllers with Varying Complexity for Pitch-Roll Coupled Failures," AIAA Guidance, Navigation and Control Conference, Portland, OR, Aug. 2011 (not yet published).

## **11. BIOGRAPHY**

Kate is the Lead Operations Engineer responsible for the airworthiness, research requirement development, hardware design, environmental testing, flight test planning, and mission controlling of the research F-18 aircraft at NASA's Dryden Flight Research Center. Her latest work supported the development of integrated aircraft control design tools and techniques to enable safe flight in the presence of adverse conditions to promote further development, maturation, and acceptance of adaptive control laws in the operational environment. She completed a Bachelors of Science in Chemical & Petroleum Engineering from the University of Pittsburgh in 2003 prior to a 4-yr active duty career as a developmental engineer responsible for system integration and test efforts of the Airborne Laser Test Bed program. Kate has continued her education with the accomplishment of a Masters of Arts in Management and Leadership and Masters of Business Administration from Webster University. She is currently working on a part-time Master's of Science in Engineering for Aeronautics and Astronautics through Purdue University as she continues with follow-on research efforts involving health management, flight dynamics and other aviation safety concepts.