

# The New Meteor Radar at Penn State: Design and First Observations

J. Urbina · R. Seal · L. Dyrud

**Abstract** In an effort to provide new and improved meteor radar sensing capabilities, Penn State has been developing advanced instruments and technologies for future meteor radars, with primary objectives of making such instruments more capable and more cost effective in order to study the basic properties of the global meteor flux, such as average mass, velocity, and chemical composition. Using low-cost field programmable gate arrays (FPGAs), combined with open source software tools, we describe a design methodology enabling one to develop state-of-the art radar instrumentation, by developing a generalized instrumentation core that can be customized using specialized output stage hardware. Furthermore, using object-oriented programming (OOP) techniques and open-source tools, we illustrate a technique to provide a cost-effective, generalized software framework to uniquely define an instrument's functionality through a customizable interface, implemented by the designer. The new instrument is intended to provide instantaneous profiles of atmospheric parameters and climatology on a daily basis throughout the year. An overview of the instrument design concepts and some of the emerging technologies developed for this meteor radar are presented.

**Keywords** meteor radar · FPGAs · software radar · open source

## 1 Introduction

Meteoroids impact and disintegrate in the Earth's atmosphere daily. Current estimates for this global meteor flux vary from 2,000-200,000 tons per year, and estimates for the average velocity range between 10 km/s and 70 km/s [Taylor, 1995; Ceplecha et al., 1998; Janches et al., 2000b; Cziczo et al., 2001; Mathews et al., 2001]. The understanding of the properties of the meteor flux is important for several fields of study which range from solar system evolution to imaging of gravity waves in the mesosphere. For example, meteoric metals are one of the sources of metal and ion layers in the mesosphere/lower thermosphere (MLT) region. They are also the source of condensation nuclei which is needed for the formation of noctilucent clouds (NLC) [Kelly and Gelinias, 2000; Smith et al., 2000; Liu et al., 2002; Rapp et al., 2003]. Yet, the basic properties of this global meteor flux, such as average mass, velocity, and chemical composition remain poorly understood [Mathews et al., 2001].

It is still unknown how the changes in the meteor flux will influence these phenomena, because current modeling efforts of the physics and chemistry of meteor atmospheric entry and ablation require better observational constraints [McNeil et al., 2002; Pellinen-Wannberg et al., 2004; Plane, 2004]. We

---

J. Urbina (✉)  
315 EE East, University Park, PA 16802. Phone: 814-863-5326; Fax: 814-863-8457; E-mail: jvu1@psu.edu

R. Seal  
University Park, PA 16802

L. Dyrud  
Applied Physics Laboratory, John Hopkins University, Columbia, MD, 20723

believe much of the mystery surrounding the basic parameters of the meteor input exists for two reasons: 1) The unknown sampling biases of different meteor observation techniques, and 2) The lack of continuous and routine measurements of radar meteors using advanced techniques. In an effort to provide new and improved meteor radar sensing capabilities, Penn State has been developing advanced instruments and technologies for future meteor radars, with primary objectives of making such instruments more capable and more cost effective in order to study the basic properties of the global meteor flux. With the rapid emergence of new standards and protocols in wireless communication, many functions of traditional radio receivers are being implemented in software [Mitola, 2000; Reed, 2002]. These new radio receivers are called software radios since their implementation relies heavily on digital signal processing techniques and require fewer radio frequency components than classic analog radios.

We describe in this paper the current implementation of an open source VHF software radar system as a first step towards developing a new generation of radar systems for meteor and astronomical science. In section 2, we describe the analysis and design of the system. Section 3 is devoted to a discussion of the software architecture and system configuration. We present first meteor observations in section 4. Finally, in section 5, a summary of the paper is presented.

## 2 System Analysis and Design

Precise definition of the problem domain is the first stage of design known as requirements analysis [Fowler, 2004]. This section discusses the techniques used to analyze, model, and implement the design of the data acquisition presented in this paper. Detailed discussion of both hardware and software are combined to better communicate their interdependence.

### 2.1 Requirements Analysis

Definition of the system's capabilities and features are best defined by users (domain experts) of the system. A preliminary list of requirements were created as a first step in the design process:

1. System users are primarily scientists.
2. Users need the ability to configure the system to meet their own specifications.
3. System configuration should be stored for later re-use.
4. Multiple configurations, cycled at predetermined intervals, are sometimes necessary for a single experiment.
5. The system will use the Linux Operating System.
6. Some experiments require large bandwidths and high storage rates.
7. Minimal real-time processing and plotting tools are necessary to ensure proper setup and equipment function.
8. Data headers are needed for data storage and retrieval. A standard format will be required.
9. Analysis software will be required for post processing.
10. Software should be able to accommodate newer hardware revisions with minimal effort.
11. Documentation is a critical component.

This list served as the framework for the design and each item was categorized according to a function. Primary tasks were identified and further refinement produced smaller, well-defined subtasks.

From this requirement analysis, 5 primary functions and 4 supporting subfunctions were defined. These tasks, having well-defined boundaries, partitioned the system into 5 primary programs of operation: 1) System Configuration Program, 2) Data Collection Program, 3) Real-Time plotting Program, 4) Post Processing Software, and 5) Data Formatting Routines. Next, the process of hardware selection followed. Hardware was categorized as follows: 1) Wide-Band digital receiver, 2) High speed general purpose computer, 3) High speed, large capacity data storage, 4) Radar pulse controller, and 5) Antenna Configuration and Control System. Due to space limitation and relevance of the acquisition system, only the wide-band receiver implementation is described below. For a complete discussion of the integration of these four components, please see [Seal, 2010].

## 2.2 Software Radar System

The software-defined radio for radar systems takes advantage of existing open source radio software created by the GNU Software Radio for AM, FM, and HDTV signal detection [<http://www.gnu.org/software/gnuradio/>]. The system is built around a PC with a 2.6 GHz AMD Phenom X4 Quad-core processor, 4 GB DDR2 RAM, with 16 1 TB SATA hard drives, and Gentoo Linux operating system. Commercially available PC boards will be used for radar controller and digitization/processing purposes. The functional diagram of the transmitting and receiving modules of the VHF radar system is shown in Figure 1.

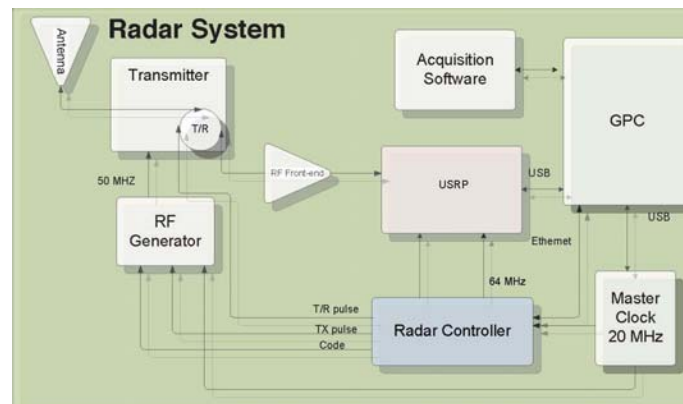

**Figure 1.** Functional diagram of the transmitting and receiving module of the 50 MHz Defined Radar for Meteor and Aeronautical Science.

The received signal from the antenna is passed through an analog band-pass filter tuned to the desired operating frequency. The next stage is a low-noise amplifier with programmable gain that boosts the signal level further. The output of this amplifier is passed through a protection circuit before it is sent to the digital receiver units where the carrier signal is sampled at 64 MHz (50 MHz carrier signal is translated to 14 MHz into the first Nyquist zone of 32 MHz) and then is digitally down converted and decimated in software to produce quadrature and in-phase baseband signals. The dynamic range of the system is about 90 dB. To ensure coherence of the transmitter/receiver, a 10 MHz oven controlled local oscillator is used to produce the clocks required by different parts of the system including the radio frequency gated signal for the transmitter. The desired frequency of operation is selected by software and set to 50 MHz (the system can be tuned to any value between 1 and 100 MHz with adequate RF front-end circuitry). Each A/D inside the digital receiver card can operate at a maximum speed of 80 Msamp/s per unit channel. With one digital receiver board the system will support a total of 4-complex

channels to serve a 4-receiver interferometric radar. If more channels are needed, the system can easily be extended to 8, 16, 32, 64, or 128 complex channels with additional receiver boards.

The system operates as follows: data acquisition software is used to load and initiate the frequency synthesizer board (that provides all the required clock for the system), load the radar controller card, configure the digital receiver boards, initiate data collection, and route the digital samples to a disk file as they become available. The radar controller will provide four control signals: a sample start trigger to the receiver board, blanking, T/R switching, and RF pulse. Additional control pulses, e.g., coding, etc., can also be provided by the counter/timer card if needed. The frequency synthesizer card will have three (more can be provided if needed) additional frequency outputs, which may be useful in frequency domain interferometry measurements. Four 5kW (20kW total peak power) transmitters with two pairs of T/R switches are used to excite the interferometric antenna. The transmitter has about 1 MHz bandwidth and a duty cycle of 10%.

Radar data collection begins when a trigger signal is applied to the external gate of the universal software radio peripheral (USRP). Next, the user application requests data from the USRP, via the driver's interface. When data is available, the user application selects a segment of data and copies it into a secondary, user allocated buffer system. This secondary system allows data sharing among multiple processes by utilizing the POSIX shared memory library and the tmpfs [Robbins, Online] file system. Tmpfs transparently allows large regions of PC RAM to be used as a standard storage device. This filesystem is, by default, dynamically resizable through the use of swap space. For high speed operation, a fixed size tmpfs is required; preventing interaction with swap space which drastically degrades performance. The POSIX shared memory library uses the tmpfs filesystem to allocate regions of memory included in the requesting process's own address space; providing data sharing among processes. Efficient buffer operation in a read/write system is accomplished using the producer/consumer (P/C) threading model [Binstock, Online]. The P/C model requires two threads: the producer thread handles data writes to the buffers, and the consumer thread manages data reads. Synchronization is controlled through a shared variable that tracks dirty buffers (buffers containing pending data). In this model, the consumer thread starts the sequence, requesting data from the first buffer. If data is not available, the consumer thread is put to sleep. Then, the producer begins filling buffers at a continuous rate; waking the consumer thread upon completion of a buffer. This operation continues indefinitely using a predetermined number of buffers. Non-real-time operating systems can impose unpredictable latencies [Seelam, Online]; violating real-time operation. Applying the P/C model, latencies can be masked through buffering; bypassing the need for a real-time operating system. Additionally, use of this model, combined with shared memory regions, allow for multiple levels of real-time processing to occur simultaneously. This approach preserves storage device bandwidth which is critical for high speed, real-time data writing. This provides a major advantage over older systems in which the storage device spent a large amount time seeking to satisfy system reads and writes; further limiting bandwidth.

### **3 First Radar Observations**

We have conducted first radar observations with the software radar system in conjunction with four 5-element Yagi antennas for transmission and a 50-MHz transmitter with peak power of 20 kW. On reception, we used five 5-element Yagi antennas in a cross configuration. The experiment was carried out with an inter-pulse period (IPP) of 1 ms and pulse width of 1 km range resolution. After a quick analysis of the meteor trails of the received data, the first results of the new system look promising.

Figure 2 shows In-Phase and Quadrature raw voltages of an underdense meteor trail. Clearly present in the signal is the attenuation or classical exponential decay of these type of reflections.

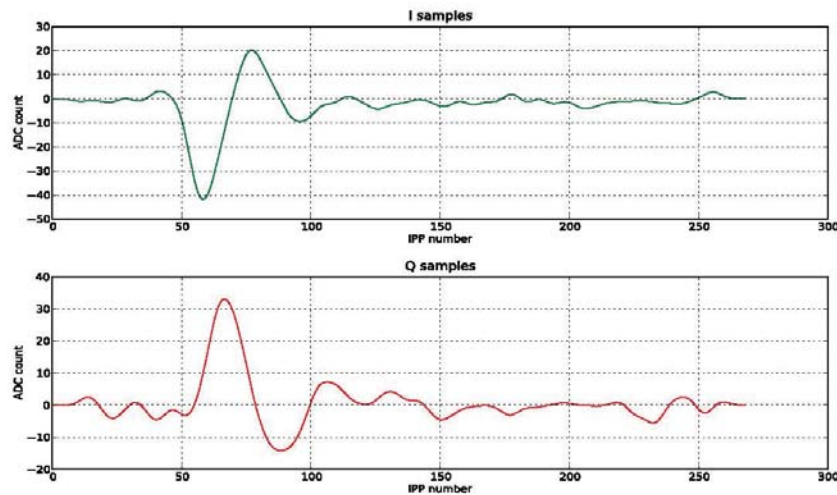

**Figure 2.** In-Phase and Quadrature raw voltages an underdense meteor trail detected on May 5, 2010.

## 4 Summary

We have presented an overview of the implementation of a new meteor system based on open source hardware and software tools. This system will be used by Communication and Space Sciences Laboratory at Penn State University to conduct meteor research. The acquisition system enables the operation of the radar with bandwidths approaching 10 MHz and data throughput greater than 30 MB/s. The system is flexible and is easily reconfigurable, allowing the user to implement newer ionospheric experiments. We will make our software radar control programs available freely through the Open Source software development web site of SourceForge at: [<http://sourceforge.net>].

## Acknowledgements

This work is supported by the National Science Foundation under grants: ATM-0638624 and ATM-0457156 to Penn State University.

## References

- Binstock, A., The producer/consumer threading model.  
[[http://www.intel.com/cd/ids/ developer/asmo-na/eng/columns/performance/52523.htm](http://www.intel.com/cd/ids/developer/asmo-na/eng/columns/performance/52523.htm)].
- Cepilecha, Z., J. Borovicka, W. G. Elford, D. O. Revelle, R. L. Hawkes, V. Porubcan, and M. Simek, Meteor phenomena and bodies, *Space Science Reviews*, 84, 327471, 1998.
- Cziczko, D. J., D. S. Thomson, and D. M. Murphy, Ablation, flux, and atmospheric implications of meteors inferred from stratospheric aerosol, *Science*, 291, 17721775, 2001.
- Fowler, M. UML Distilled Third Edition. Pearson Education, Inc., 2004.
- Janches, D., J. D. Mathews, D. D. Meisel, and Q. H. Zhou, Micrometeor Observations Using the Arecibo 430 MHz Radar, *Icarus*, 145, 5363, 2000b.

- Kelly, M. C., and L. J. Gelinas, Gradient drift instability in midlatitude sporadic E layers: localization of physical and wavenumber space, *Geophysical Research Letters*, 27, 457, 2000.
- Liu, A. Z., W. K. Hocking, S. J. Franke, and T. Thayaparan, Comparison of Na lidar and meteor radar wind measurements at Starfire Optical Range, NM, USA, *Journal of Atmospheric and Terrestrial Physics*, 64, 3140, 2002.
- Mathews, J. D., D. Janches, D. D. Meisel, and Q.-H. Zhou, The micrometeoroid mass flux into the upper atmosphere: Arecibo results and a comparison with prior estimates, *Geophys. Res. Lett.*, 28, 1929, 2001.
- Mitola, J. III *Software Radio Architecture: Object Oriented Approaches to Wireless Systems Engineering*, John Wiley and Sons Inc., 2000.
- McNeil, W. J., E. Murad, and A. J. M. C. Plane, Models of Meteoric Metals in the Atmosphere, pp.265, *Meteors in the Earths atmosphere*. Edited by Edmond Murad and Iwan P. Williams. Publisher: Cambridge, UK: Cambridge University Press, 2002., p.265, 2002.
- Pellinen-Wannberg, A., E. Murad, B. Gustavsson, U. Brandstrom, C. Enell, C. Roth, I. P. Williams, and A. Steen, Optical observations of water in Leonid meteor trails, *Geophys. Res. Lett.*, 31, 3812, 2004.
- Plane, J. M. C., A time-resolved model of the mesospheric Na layer: constraints on the meteor input function, *Atmospheric Chemistry and Physics*, 4, 627638, 2004.
- Rapp, M., F. Lubken, P. Hoffmann, R. Latteck, G. Baumgarten, and T. A. Blix, PMSE dependence on aerosol charge number density and aerosol size, *Journal of Geophysical Research (Atmospheres)*, 108,81, 2003.
- Reed, J. H., *Software Radio A Modern Approach to Radio Engineering*, Prentice Hall Communications Engineering and Emerging Technologies Series, 2002.
- Robbins, D., *Common threads: Advanced filesystem implementors guide*, part 3. [<http://www-128.ibm.com/developerworks/library/l-fs3.html>].
- Seal, R., J. Urbina, M. Sulzer, S. Gonzalez, N. Aponte, Design of an FPGA-based radar controller, National Radio Science Meeting, Boulder, CO, January 3-6, 2008.
- Seal, R., A new generation of meteor radar systems, MS thesis, Penn State University, University Park, PA, 16802, 2010.
- Seelam, S., J. S. Babu, and P. Teller, Automatic i/o scheduler selection for latency and bandwidth optimization, 4th International Conference on Parallel Architectures and Compilation Techniques, 2005. [<http://pact05.ce.ucsc.edu/>].
- Smith, S. M., M. Mendillo, J. Baumgardner, and R. R. Clark, Mesospheric gravity wave imaging at a subauroral site: First results from Millstone Hill, *Journal of Geo-physical Research*, 105, 27,11927,130, 2000.
- Taylor, A.D., The Harvard Radio Meteor Project meteor velocity distribution reap-praised, *Icarus*, 116, 205-209,1995.