

The Division Factor (w_D) was calculated as a function of reduced density (ρ_r) for several binary fluid mixtures. The curves were calculated by use of $\delta_D = c\rho_r^{3/2}$, where $c = 0.42$ and $c = 0.58$.

and the model evaluated by means of correlations with experimental data from the literature (see figure). Typical uncertainties in the correlations have been estimated to lie between 10 and 15 percent and to reach a maximum of about 30 percent at high density.

Simulations of heptane drops in nitrogen under zero gravity and at high pressure were performed using the model in order to investigate the sensitivities of predicted drop diameters to uncertainties in diffusivity values. The results of the simulations showed that the root-mean-square deviations of relative drop diameters were approximately one-fourth of the corresponding imposed relative changes in diffusivities.

This work was done by Josette Bellan and Kenneth Harstad of Caltech for NASA's Jet Propulsion Laboratory. Further information is contained in a TSP (see page 1). NPO-30409

Fresnel Lenses for Wide-Aperture Optical Receivers

These would be relatively inexpensive, lightweight alternatives to conventional telescope lenses.

NASA's Jet Propulsion Laboratory, Pasadena, California

Wide-aperture receivers for free-space optical communication systems would utilize Fresnel lenses instead of conventional telescope lenses, according to a proposal. Fresnel lenses weigh and cost much less than conventional

lenses having equal aperture widths. Plastic Fresnel lenses are commercially available in diameters up to 5 m — large enough to satisfy requirements for aperture widths of the order of meters for collecting sufficient light in typ-

ical long-distance free-space optical communication systems.

Fresnel lenses are not yet suitable for high-quality diffraction-limited imaging, especially in polychromatic light. However, optical communication systems utilize monochromatic light, and there is no requirement for high-quality imaging; instead, the basic requirement for an optical receiver is to collect the incoming monochromatic light over a wide aperture and concentrate the light onto a photodetector.

Because of lens aberrations and diffraction, the light passing through any lens is focused to a blur circle rather than to a point. Calculations for some representative cases of wide-aperture non-diffraction-limited Fresnel lenses have shown that it should be possible to attain blur-circle diameters of less than 2 mm. Preferably, the blur-circle diameter should match the width of the photodetector. For most high-bandwidth communication applications, the required photodetector diameters would be about 1 mm. In a less-preferable case in which the blur circle was wider than a single photodetector, it would be possible to occupy the blur circle with an array of photodetectors.

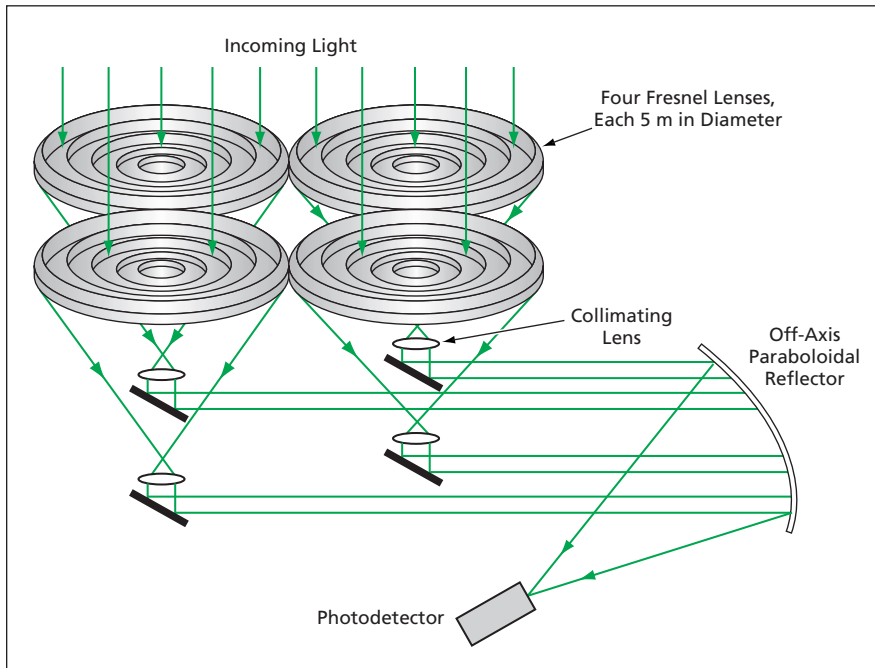

Incoming Light Would Be Collected by four Fresnel lenses, then the light would be collimated and concentrated onto a single photodetector.

As an alternative to using a single large Fresnel lens, one could use an array of somewhat smaller lenses to synthesize the equivalent aperture area. Such a configuration might be preferable in a case in which a single Fresnel lens of the requisite large size would be impractical to manufacture, and the blur circle could not be made small enough. For example one could construct a square array of four 5-m-diameter Fresnel lenses to obtain the same light-collecting area as that of a single 10-m-diameter lens. In that case (see fig-

ure), the light collected by each Fresnel lens could be collimated, the collimated beams from the four Fresnel lenses could be reflected onto a common off-axis paraboloidal reflector, and the paraboloidal reflector would focus the four beams onto a single photodetector. Alternatively, detected signal from each detector behind each lens would be digitized before summing the signals.

This work was done by Hamid Hemmati of Caltech for NASA's Jet Propulsion Laboratory. Further information is contained in a TSP (see page 1).

In accordance with Public Law 96-517, the contractor has elected to retain title to this invention. Inquiries concerning rights for its commercial use should be addressed to:

*Innovative Technology Assets Management
JPL*

Mail Stop 202-233

4800 Oak Grove Drive

Pasadena, CA 91109-8099

(818) 354-2240

E-mail: iaoffice@jpl.nasa.gov

Refer to NPO-40436, volume and number of this NASA Tech Briefs issue, and the page number.