

The integer and fractional phase-counter outputs are also fed to accumulators to compute the sum of many phase measurements over a programmed interval. The sum is then used to compute an average. The summing interval can be made to repeat at a fixed frequency, typically in the range between 1 Hz and 1 kHz, that is defined by a signal from a summation-synchronizing clock. The averaging interval can be programmed to

start any time after the summation-synchronizing clock signal and can continue for any time up to the next such signal. During the summation, each negative-going transition of the unknown signal causes a phase measurement to be summed into the integer and fractional phase accumulators. As a result, the number of readings in an average equals the duration of the summation interval multiplied by the unknown heterodyne

frequency; for example, if the heterodyne frequency is 10 kHz and the summation interval is 0.1 second, then 1,000 measurements are accumulated.

*This work was done by Donald Johnson, Robert Spero, Stuart Shaklan, Peter Halverson, and Andreas Kuhnert of Caltech for NASA's Jet Propulsion Laboratory. Further information is contained in a TSP (see page 1).
NPO-30866*

Optoelectronic Instrument Monitors pH in a Culture Medium

This instrument is noninvasive and is not significantly affected by biofilm.

Lyndon B. Johnson Space Center, Houston, Texas

An optoelectronic instrument monitors the pH of an aqueous cell-culture medium in a perfused rotating-wall-vessel bioreactor. The instrument is designed to satisfy the following requirements:

- It should be able to measure the pH of the medium continuously with an accuracy of ± 0.1 in the range from 6.5 to 7.5.
- It should be noninvasive.
- Any material in contact with the culture medium should be sterilizable as well as nontoxic to the cells to be grown in the medium.
- The biofilm that inevitably grows on any surface in contact with the medium should not affect the accuracy of the pH measurement.
- It should be possible to obtain accurate measurements after only one calibration performed prior to a bioreactor cell run.
- The instrument should be small and lightweight.

The instrument includes a quartz cuvette through which the culture medium flows as it is circulated through the bioreactor. The cuvette is sandwiched between light source on one side and a photodetector on the other side. The

light source comprises a red and a green light-emitting diode (LED) that are repeatedly flashed in alternation with a cycle time of 5 s. The responses of the photodiode to the green and red LEDs are processed electronically to obtain a quantity proportional to the ratio between the amounts of green and red light transmitted through the medium.

The medium contains some phenol red, which is an organic pH-indicator dye. Phenol red dissociates to a degree that is a known function of pH and temperature, and its optical absorbance at the wavelength of the green LED (but not at the wavelength of the red LED) varies accordingly. Hence, the pH of the medium can be calculated from the quantity obtained from the photodetector responses, provided that calibration data are available.

During the calibration procedure, the dyed culture medium to be used in the bioreactor is circulated through the cuvette and the photodetector responses are processed and recorded while small amounts of hydrochloric acid are added to the medium from time to time to make the pH decrease in small increments through the pH range from 7.5 to 6.5. For each set of measurements, the

pH is determined by conventional means. Then the resulting data are fitted with a second-order polynomial, the coefficients of which are thereafter used to compute the pH as a function of the aforementioned quantity proportional to the ratio between the amounts of green and red light transmitted.

The cuvette is the only part of the instrument in contact with the culture medium. The cuvette can readily be sterilized, either separately from or as incorporated into the bioreactor system, by use of an autoclave or by use of ethylene oxide. Tests have shown that the error in the pH measurement by this instrument does not range beyond ± 0.1 pH unit, even when a biofilm is present. As required, the instrument is lightweight (total mass, including electronic circuitry, only 150 g) and compact [overall dimensions of 1.0 by 1.5 by 2.5 in. (approximately 2.5 by 3.8 by 6.4 cm)].

*This work was done by Melody M. Anderson and Neal Pellis of Johnson Space Center and Anthony S. Jeevarajan and Thomas D. Taylor of Wyle Laboratories. For further information, contact the Johnson Commercial Technology Office at (281) 483-3809.
MSC-23107*

Imaging of γ -Irradiated Regions of a Crystal

Electron-trapping and photorefractive effects are exploited.

NASA's Jet Propulsion Laboratory, Pasadena, California

A holographic technique has been devised for generating a visible display of the effect of exposure of a photorefractive crystal to γ rays. The technique exploits the space charge that results from

trapping of electrons in defects induced by γ rays.

The technique involves a three-stage process. In the first stage, one writes a holographic pattern in the crystal by use

of the apparatus shown in Figure 1. A laser beam of 532-nm wavelength is collimated and split into signal and reference beams by use of a polarizing beam splitter. On its way to the crystal, the ref-

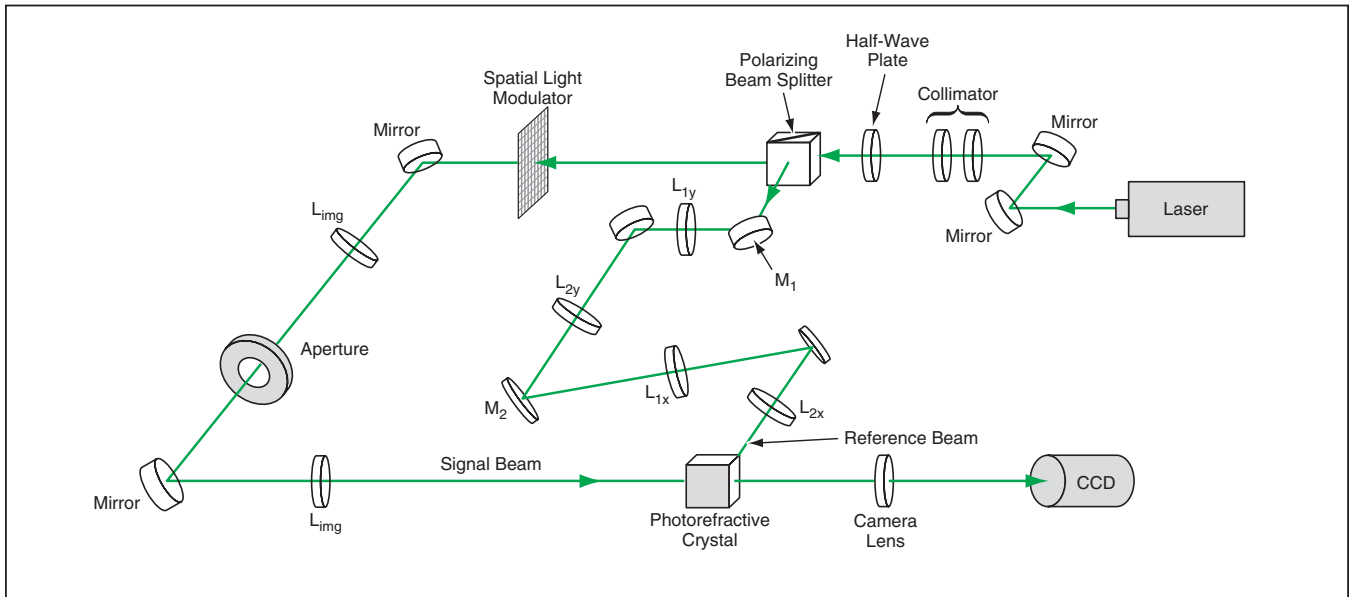

Figure 1. A Hologram Is Formed in a Crystal to be exposed to γ rays. After exposure to γ rays, the crystal is remounted in this apparatus for reading of the hologram.

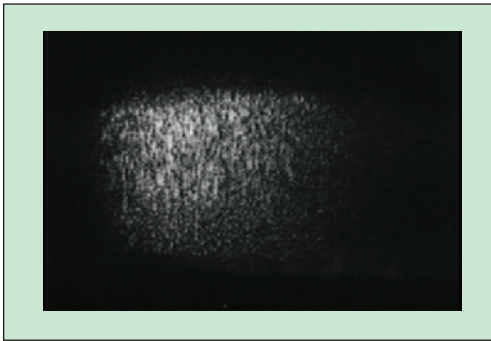

Figure 2. This Image Shows the Effect of γ Rays that have passed through a crystal of Fe:LiNbO₃.

reference beam goes through a two-dimensional optical scanner that contains two pairs of lenses (L_{1y}, L_{2y} and L_{1x}, L_{2x}) and mirrors M_1 and M_2 , which can be rotated by use of micrometer drives to make fine adjustments. The signal beam

is sent through a spatial light modulator that imposes the holographic pattern, then through two imaging lenses L_{img} on its way to the crystal. An aperture is placed at the common focus of lenses L_{img} to suppress high-order diffraction from the spatial light modulator. The hologram is formed by interference between the signal and reference beams.

A camera lens focuses an image of the interior of the crystal onto a charge-coupled device (CCD). If the crystal is illuminated by only the reference beam once the hologram has been formed, then an image of the hologram is formed on the CCD: this phenomenon is exploited to make visible the pattern of γ irradiation of the crystal, as described next.

In the second stage of the process, the crystal is removed from the holographic apparatus and irradiated with γ rays at a dose of about 100 krad. In the third stage of the process, the crystal is remounted in the holographic apparatus in the same position as in the first stage and illuminated with only the reference beam to obtain the image of the hologram as modified by the effect of the γ rays. The orientations of M_1 and M_2 can be adjusted slightly, if necessary, to maximize the intensity of the image. Figure 2 shows such an image that was formed in a crystal of Fe:LiNbO₃.

This work was done by Danut Dragoi, Steven McClure, Allan Johnston, and Tien-Hsin Chao of Caltech for NASA's Jet Propulsion Laboratory. Further information is contained in a TSP (see page 1). NPO-30622

Photodiode-Based, Passive Ultraviolet Dosimeters

Outputs of photodiodes are fed to coulometers.

Marshall Space Flight Center, Alabama

Simple, passive instruments have been developed for measuring the exposure of material specimens to vacuum ultraviolet (VUV) radiation from the Sun. Each instrument contains a silicon photodiode and a coulometer. The photocharge generated in the photodiode is stored in the coulometer. The accumulated electric charge measured by use of the coulometer is assumed to be propor-

tional to the cumulative dose of VUV radiation expressed in such convenient units as equivalent Sun hours (ESH) [defined as the number of hours of exposure to sunlight at normal incidence]. Intended originally for use aboard spacecraft, these instruments could also be adapted to such terrestrial uses as monitoring the curing of ultraviolet-curable epoxies.

Each instrument includes a photodiode and a coulometer assembly mounted on an interface plate (see figure). The photodiode assembly includes an aluminum housing that holds the photodiode, a poly(tetrafluoroethylene) cosine receptor, and a narrow-band optical filter. The cosine receptor ensures that the angular response of the instrument approxi-