

Laboratory for Atmospheres: Instrument Systems Report

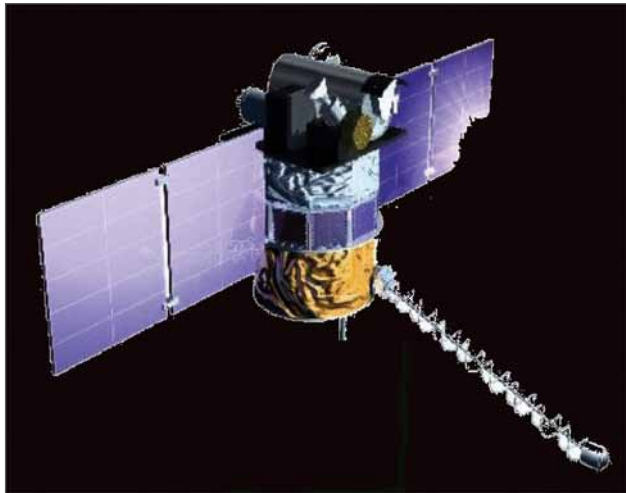

The NASA STI Program Office ... in Profile

Since its founding, NASA has been dedicated to the advancement of aeronautics and space science. The NASA Scientific and Technical Information (STI) Program Office plays a key part in helping NASA maintain this important role.

The NASA STI Program Office is operated by Langley Research Center, the lead center for NASA's scientific and technical information. The NASA STI Program Office provides access to the NASA STI Database, the largest collection of aeronautical and space science STI in the world. The Program Office is also NASA's institutional mechanism for disseminating the results of its research and development activities. These results are published by NASA in the NASA STI Report Series, which includes the following report types:

- **TECHNICAL PUBLICATION.** Reports of completed research or a major significant phase of research that present the results of NASA programs and include extensive data or theoretical analysis. Includes compilations of significant scientific and technical data and information deemed to be of continuing reference value. NASA's counterpart of peer-reviewed formal professional papers but has less stringent limitations on manuscript length and extent of graphic presentations.
- **TECHNICAL MEMORANDUM.** Scientific and technical findings that are preliminary or of specialized interest, e.g., quick release reports, working papers, and bibliographies that contain minimal annotation. Does not contain extensive analysis.
- **CONTRACTOR REPORT.** Scientific and technical findings by NASA-sponsored contractors and grantees.

- **CONFERENCE PUBLICATION.** Collected papers from scientific and technical conferences, symposia, seminars, or other meetings sponsored or cosponsored by NASA.
- **SPECIAL PUBLICATION.** Scientific, technical, or historical information from NASA programs, projects, and mission, often concerned with subjects having substantial public interest.
- **TECHNICAL TRANSLATION.** English-language translations of foreign scientific and technical material pertinent to NASA's mission.

Specialized services that complement the STI Program Office's diverse offerings include creating custom thesauri, building customized databases, organizing and publishing research results . . . even providing videos.

For more information about the NASA STI Program Office, see the following:

- Access the NASA STI Program Home Page at <http://www.sti.nasa.gov/STI-homepage.html>
- E-mail your question via the Internet to help@sti.nasa.gov
- Fax your question to the NASA Access Help Desk at (443) 757-5803
- Telephone the NASA Access Help Desk at (443) 757-5802
- Write to:
NASA Access Help Desk
NASA Center for AeroSpace Information
7115 Standard Drive
Hanover, MD 21076

Cover Caption:

More information can be found at the Laboratory Web site:<http://atmospheres.gsfc.nasa.gov>

NASA/TP-2011-215875

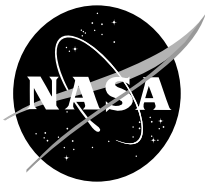

Laboratory for Atmospheres: Instrument Systems Report

National Aeronautics and
Space Administration

Goddard Space Flight Center
Greenbelt, Maryland 20771

July 2011

Trade names and trademarks are used in this report for identification only. Their usage does not constitute an official endorsement, either expressed or implied, by the National Aeronautics and Space Administration.

Available from:

NASA Center for AeroSpace Information
7115 Standard Drive
Hanover, MD 21076-1320

National Technical Information Service
5285 Port Royal Road
Springfield, VA 22161

Executive Summary

Studies of the atmosphere require a comprehensive set of observations, relying on instruments flown on spacecraft, aircraft, and balloons, as well as those deployed on the surface. The Laboratory of Atmospheres has an active program of instrument systems development that provides: 1) information leading to a basic understanding of atmospheric processes and their relationships with the Earth's climate system, 2) prototypes for future flight instruments, 3) instruments to serve as calibration references for satellite mission planning and 4) instruments for future field validation campaigns that support ongoing space missions. Laboratory scientists participate in the design of the instruments, data processing algorithms, calibration techniques, and the data processing systems. The Laboratory has well-equipped labs and test equipment to support the development and testing of instrument systems. For example, a radiometric calibration and development facility exists that supports the calibration for ultraviolet and visible (UV/VIS) space-borne solar backscatter instruments. A class 10,000 clean room is maintained.

The features and characteristics of 36 instrument systems that currently exist or are under development are summarized in this document. The report is organized into five sections: Lidar, Passive Optical, Microwave, In-Situ, and Research and Development. The first four sections summarize existing systems that are considered operational in that they are performing measurements in the laboratory or have operated in the field and are capable of being deployed on short notice. The fifth section describes systems that are under study, of low Technical Readiness Level (TRL), or of new designs undergoing development and testing.

The lidar systems in Section 1 are designed for surface or airborne platforms for measurements of clouds, aerosols, methane, water vapor pressure, temperature and winds. Lasers capable of generating radiation from 300 nm to 1100 nm are available, as is a corresponding range of sensitive photon detectors. The various systems provide high sensitivity measurements based on returns from backscatter, or Raman scattering, including intensity and polarization. Measurements of the frequency (Doppler) shift of light scattered from various atmospheric constituents can also be made.

The passive optical sensors in Section 2 operate on the surface or from aircraft. The Solar Disk Sextant (SDS) is the single balloon-borne platform. The systems consist of radiometers and spectrometers that measure atmospheric parameters such as trace gases, aerosols, optical properties, or altitude profiles of various species. The systems operate mostly in the spectral bands from 300 nm to 940 nm; one system (SMART) reaches 1,230 nm. Spatial resolution is typically in the 0.5–1 km range; spectral resolution is generally in the 0.5 nm range.

Section 3 contains summaries of microwave sensors that are deployed on the surface or in aircraft. The systems consist of both active (radar) and passive (radiometer) systems. These systems are important for studies of processes involving water in various forms. The dielectric properties of water in various forms affect microwave brightness temperatures, which are separable into atmospheric parameters such as rainfall rate and key elements of the hydrological cycle. The radar systems operate in the range from 9.6 GHz to 94 GHz and have measurement accuracies from -5 to 1 dBZ; radiometers operate in the 50 GHz to 874 GHz range with accuracies from 0.5 to 1 degree K.

An important in situ capability is discussed in Section 4. COMMIT is a complete mobile facility housed in a 20-foot trailer that had traveled widely over the globe in conjunction with SMART (passive optical) to support numerous field and validation campaigns.

Section 5 covers systems that are not yet available for experimental operations. Seven instruments fall into this category with at least one in each of the three areas previously described. Four of the systems are entirely new designs while the remaining three are improvements over existing systems. All of the instruments are intended to support and contribute to future space missions which include GPM, IceSat-2, ASCENDS, ACE, Geo-CAPE, and 3D Winds.

Instrument systems evolve and change over time and therefore the report will be updated as required, typically every three to five years. The previous report was completed in 2005; 18 new instruments programs began since that time and are included in the 2010 report. A copy of this report can be found on the Laboratory for Atmospheres Web site at <http://atmospheres.gsfc.nasa.gov/>.

We wish to thank all of the Laboratory members who contributed material on the various instrument systems, and especially the efforts of Chuck Cote (GEST/Caelum Research) who managed and coordinated the report preparation as well as Judith Clark (TIMS) and Omega Williams for their formatting, proofreading, editing, and printing support.

Sincerely,



William K-M Lau, Chief



James R. Irons, Associate Chief

Table of Contents

Scientific Products and Measurements Parameters.....	v
Lidar Instrument Systems	1
ALVICE	2
AROTAL.....	4
AT Lidar	6
CPL.....	8
GLOW.....	10
HARLIE.....	12
KILT	14
MABEL.....	15
The NASA Micro Pulse Lidar Network.....	16
RASL	18
STROZ LITE.....	20
THOR	22
TWILITE.....	24
UAV CPL.....	26
Passive Optical Instrument Systems.....	27
ACAM	28
Brewer	29
EPIC	30
GeoSpec.....	32
PACS Polarimeter.....	33
Pandora and Cleo.....	34
SDS	36
SMART	38
In Situ Instrument Systems	41
COMMIT	42
Microwave Instrument Systems.....	45
ACHIEVE.....	47
CoSMIR.....	48
CoSSIR.....	50
CRS	52
EDOP	54
HIWRAP	56
Research and Development Instrument Systems	59
Broadband Lidar for Precision CO ₂ Measurement	61
CATS	62
EXRAD	64
Fabry-Perot Based Sensor for Trace Atmospheric Species	66
GCAS	67
In Situ Airborne Formaldehyde Experiment.....	68
Acronymns.....	69

Scientific Products and Measurements Parameters

The Laboratory is constantly seeking new opportunities for instrument concepts that promote NASA Earth Science objectives, leading eventually to new space-based remote sensing systems. The approach that is used to accomplish this is the scientific process shown in Figure 1. The process begins with a scientific question raised by a NASA goal or objective and proceeds through the various phases and results in new science outcomes. This science-to-science approach is repeated with each new opportunity.

During the process, mission goals are formulated to address an important scientific problem, hypothesis, or both. Definition of the measurement requirements is a key process and identifies the geophysical parameters of specific interest to Laboratory investigators. Instrument development begins with a concept definition and design followed by synthesis and fabrication. Laboratory and field models are then built and tested. Stringent requirements are placed on measurement accuracies in order to understand fully the complexity and variability of Earth science processes. This requires careful attention to calibration procedures to remove error sources and biases from instruments and data-processing algorithms. Uncertainties are uncovered and characterized through field and sub-orbital campaigns that provide feedback to hardware or software designs to improve accuracy and performance. These lead to a better understanding of physical parameters in the context of retrievals of these parameters from remote sensing. Field campaigns may be carried out jointly between government organizations, universities and other research institutions, under agency, or national or international programs. The successive feedback and refinement process continues throughout the lifetime of all atmospheric instrument systems. Calibration and Validation (CalVal) is therefore an essential element of Earth science research prior to and during flight operations. Some ground validation systems take the form of complete multi-instrument mobile vans or trailers that are never intended for space. They provide measurements to validate space-derived products, including calibration.

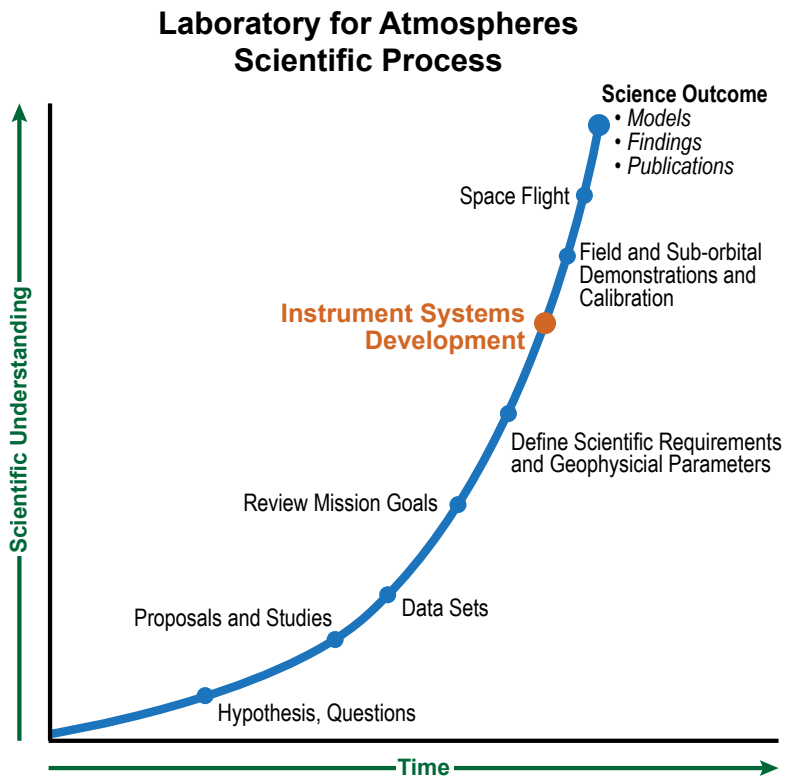

Figure 1. Instrument Systems Development (in orange) is the subject of this report.

The final phases shown in Figure 1 are space flight and the generation of scientific outcomes (products) derived from sensor measurements. As systems migrate through the various phases of the NASA project cycle, Principal Investigators (PIs) and Instrument Scientists have the responsibility to ensure that scientific integrity is maintained throughout all development and testing phases. They are essential participants and stakeholders in any decision process that affects the performance or cost of an instrument, and are responsible to the scientific community to explain any constraints imposed by limited resources or schedule.

Data are the primary product of NASA experimentation and provide the underpinnings for all scientific findings and outcomes. Raw data are transformed into products through data-processing algorithms. Design, development, and testing of retrieval algorithms is an essential aspect of the scientific measurement process. Regional or global

computer models are used to place the data in a larger context and derive useful information. They add to our existing knowledge and enhance our capability to draw conclusions relative to the original scientific formulation and hypothesis.

Peer reviewed publications are essential to the success of an experimental campaign or mission. Laboratory scientists have established an impressive record of publications and citations over the years based on data products from various stages of the instrument formulation, from laboratory fabrication to space flight. A list of yearly publications can be found the Laboratory website: <http://atmospheres.gsfc.nasa.gov/>.

Concerns over changes in aerosols, clouds, precipitation, atmospheric composition including ozone depletion/recovery, and their impacts on water and energy cycle, air quality, greenhouse gas warming, and climate change are among the many questions and issues that are addressed through these measurements and their corresponding satellite retrievals. Figure 2 shows a summary of products generated by our instrument systems that support this research on the atmosphere. Much of the data are available for scientific studies and can be found through URLs identified in the individual instrument system summaries or through direct contact with PIs and their collaborators.

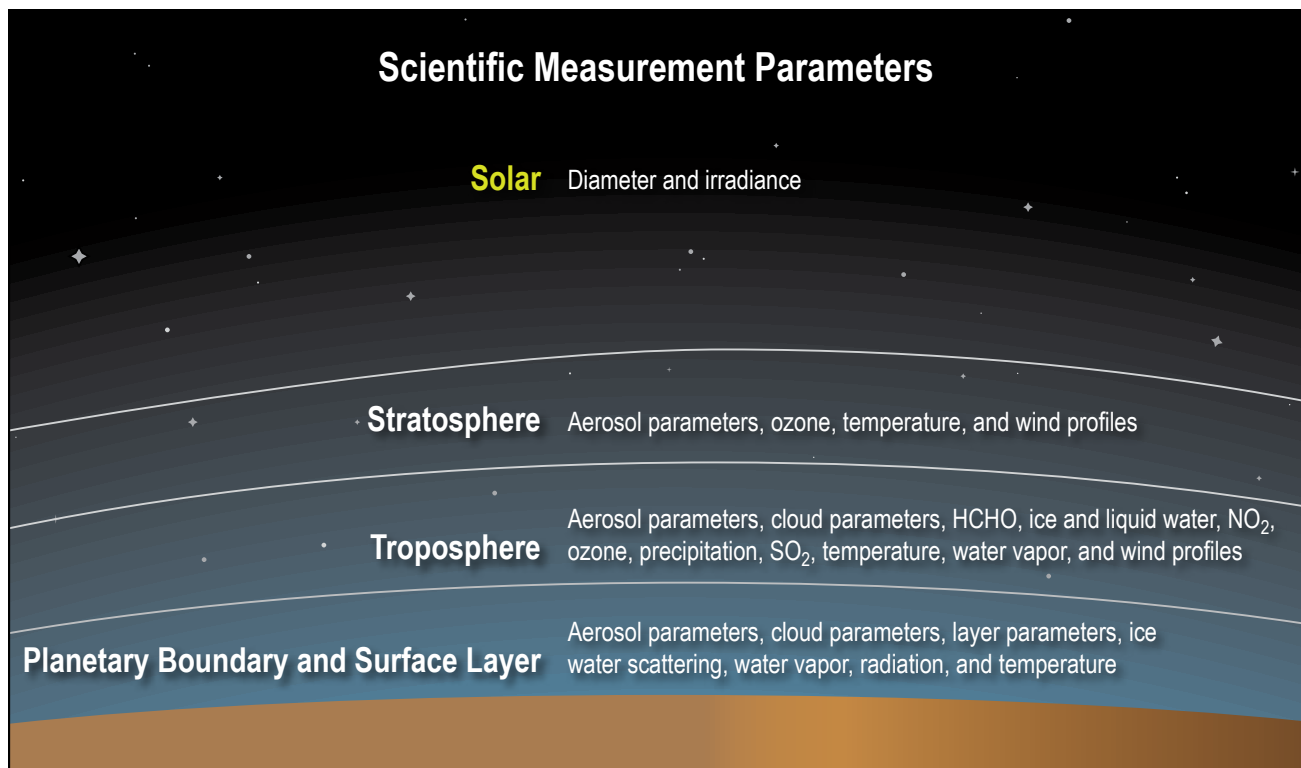

Figure 2. Summary of atmospheric research products.

Lidar Instrument Systems

ALVICE

The Atmospheric Lidar for Validation, Interagency Collaboration and Education



Graduate student operating the ALVICE instrument during MOHAVE-II.

Key Facts

- Heritage: Marine boundary-layer lidar, 1980 – 1989, Scanning Raman Lidar, 1990 – 2006.
- ALVICE is the upward looking configuration of the Raman Airborne Spectroscopic Lidar. It makes use of Raman scattering in the atmosphere to measure various atmospheric properties.
- Participated in three MOHAVE measurement campaigns hosted at NASA's Jet Propulsion Laboratory, Table Mountain Facility and three WAVES campaigns hosted at the Howard University Beltsville Campus.
- Nominal field configuration: All of the ALVICE instrumentation, including the laser, telescope, and data acquisition electronics, is housed within a single environmentally controlled mobile trailer, which also supplies workspace for several experimenters.

Description

Water is the most active infrared molecule in the atmosphere; water vapor response is a major factor in any global warming triggered by increasing carbon dioxide. Over the coming decades, upper tropospheric water vapor is anticipated

to increase due to climate change, providing a significant additional radiative feedback in the atmosphere. Monitoring the changes in atmospheric water vapor due to climate change is a central focus of two international networks: NDACC (Network for the Detection of Atmospheric Composition Change) and GRUAN (GCOS Reference Upper Air Network). ALVICE is participating in both networks as a calibration transfer instrument to aid in acquiring climate quality data records over an extended period from diverse sites.

ALVICE Data Products

- Water vapor mixing ratio
- Aerosol scattering ratio
- Aerosol extinction
- Aerosol backscattering coefficient
- Aerosol extinction/backscatter ratio
- Aerosol depolarization
- Cloud optical depth
- Cloud liquid water
- Rotational Raman temperature measurements
- Ice water scattering and cirrus optical depth

ALVICE Parameters

- Laser wavelength: 355 nm
- Laser pulse energy: 350 mJ at 50 Hz
- Laser pulse length: 7 ns
- FOV: 25 μ rad, 0.6 m aperture
- Optical channels: 354.7, 375, 386.7, 403.2, and 407 nm

Principal Investigator

David N. Whiteman
NASA's Goddard Space Flight Center
David.N.Whiteman@nasa.gov

ALVICE Team Members/Co-Investigators

Martin Cadirola
Electronic Systems, Ecotronics, Inc.

Gerry McIntire
SGT

Demetrius Venable
Howard University

Kevin Vermeesch
Science Systems and Applications, Inc.

Igor Veselovskii
University of Maryland, Baltimore County

Science Goals for Future Campaigns

- Serve as a calibration/validation transfer standard for water vapor measurements within the Network for the Detection of Atmospheric Composition Change.

- Study the measurement requirements to detect trends in atmospheric water vapor.

References

Whiteman, D.N., K. Rush, S. Rabenhorst, W. Welch, M. Cadirola, G. McIntire, F. Russo, M. Adam, D. Venable, R. Connell, I. Veselovskii, R. Forno, B. Mielke, B.d Stein, T. Leblanc, S. McDermid, H. Vömel, 2010. "Airborne and ground-based measurements using a high-performance Raman lidar, *J. Atmos. Oceanic Technol.*, **27** (11), 1781–1801.

AROTAL

Airborne Raman Ozone, Temperature, and Aerosol Lidar



AROTAL in a DC-8 with an up-looking telescope (the black cylinder) and one laser showing.

Key ARODAL Facts

- Heritage: Originally designed for temperature and methane; modified to include temperature, ozone, and aerosol.
- A visible infrared/ultraviolet lidar for polar atmospheric measurements above 12 km.
- Participated in the 1999–2000 SOLVE campaign and the 2003 SAGE III validation campaign in Kiruna, Sweden.
- Nominal field configuration: Designed for deployment on the NASA DC-8 aircraft with the telescope looking up through a 16-in diameter quartz window.
- ARODAL URL: <http://hyperion.gsfc.nasa.gov>

Description

Ozone loss in the polar stratosphere is directly caused by catalytic chlorine and bromine reactions. The high levels of reactive chlorine occur because of reactions of reservoir chlorine species on the surfaces of polar stratospheric clouds (PSCs). Temperature plays a key role in the formation and lifetime of PSCs. In part because of temperature's pivotal role, ARODAL provides high-resolution profiles of the arctic temperature fields. Lidar retrievals from the DC-8 provide high-precision temperature profiles, along with measurements of ozone, aerosols, clouds, and water vapor throughout the region of interest. These measurements were designed to help understand the conditions under which PSCs form and persist by identifying regions in the lower Arctic stratosphere where temperatures were low enough for PSCs to persist (195 K or lower).

AROTAL is made up of three major components: the transmitter, the receiver, and the data acquisition system. The transmitter comprises two different lasers: an XeCl excimer laser, transmitting 308 nm; and a Nd-YAG laser, transmitting at 1064, 532, and 355 nm. The primary receiver is a 16-in Newtonian telescope. The visible and infrared radiation is split from the ultraviolet wavelengths; the 532 nm radiation is polarized 90° to the transmitted 532 nm radiation and is also collected. Ultraviolet returns are separated into four wavelengths: the two transmitted wavelengths at 308 and 355 nm, as well as the Raman scattered return from atmospheric N₂ at 332 and 387 nm.

AROTAL Data Products

Vertical profiles of:

- O₃ from 14–30 km
- Temperature, 13–60 km
- Aerosol scattering
- Aerosol depolarization at 532 nm

AROTAL Parameters

- Laser wavelengths: 308, 355, 532, and 1064 nm
- Laser pulse energy: 200 mJ
- Pulse Rate: 50 Hz at 1064, 532, and 355 nm; 200 Hz at 308 nm
- Field of view: typically 2 mrad (variable)
- Optical channels: 308, 332, 355, 387, 532, and 1064 nm
- Horizontal resolution: 4–48 km
- Vertical resolution: 0.5–1.5 km

Principal Investigator

Thomas J. McGee
NASA's Goddard Space Flight Center
Thomas.J.McGee@nasa.gov

AROTAL Team Members

John Burris, (Co-PI)
NASA's Goddard Space Flight Center

Robert Farmer
NASA's Goddard Space Flight Center

William Heaps
NASA's Goddard Space Flight Center

Walter Hoegy
NASA's Goddard Space Flight Center

Chris Hostetler
NASA's Langley Research Center

Leslie Lait
Science Systems and Applications, Inc.

Chip Trepte
NASA's Langley Research Center

Lawrence Twigg
Science Systems and Applications, Inc.

Co-Investigators

Paul Newman
NASA's Goddard Space Flight Center

Stuart McDermid
NASA's Jet Propulsion Laboratory

Science Questions for Future Campaigns

- What is the validity of the ozone measuring instruments on board the Aura satellite?
- What is the effect of the ozone variability within the Aura measurement footprint?

References

Burris, J., T. McGee, W. Hoegy, L. Lait, L. Twigg, G. Sumnicht, W. Heaps, C. Hostetler, T. Bui, R. Neuber, and I.S. McDermid, 2002: Validation of temperature measurements from the Airborne Raman Ozone Temperature and Aerosol Lidar (AROTAL) during SOLVE. *J. Geophys. Res.*, **107**, D20, 8286–8296.

Burris, J., T. McGee, W. Hoegy, P. Newman, L. Lait, L. Twigg, G. Sumnicht, W. Heaps, C. Hostetler, R. Neuber, and K. Kunzi, 2002: Lidar temperature measurements during the SOLVE campaign and the absence of PSCs from regions of very cold air. *J. Geophys. Res.*, **107**, D20, 8297–8306.

AT Lidar

Aerosol and Temperature Lidar



AT Lidar operating at GSFC; 532 nm beam is clearly visible.

Key AT Lidar Facts

- Heritage: Originally designed for stratospheric parameters; modified to include the troposphere.
- The AT Lidar is an elastic and Raman backscatter lidar designed for aerosol and temperature profiling in the stratosphere and above; and for tropospheric water vapor and temperature, cirrus cloud parameters, and temperature within cirrus clouds.
- Nominal field configuration: The system is mobile and is housed in a large, environmentally controlled trailer.

Description

This Lidar system has high sensitivity aerosol and temperature capabilities using two separate Nd-YAG lasers to transmit three different wavelengths: 1064, 532, and 355 nm. Returns from the spectrally narrow transmitted 1064 and 532 nm beams are used to measure aerosol backscatter into the stratosphere. The depolarization ratio of the 532 nm radiation is measured to determine the physical state of the particles. The transmitted 532 nm beam is spectrally narrow and rotational. Raman lines scattered from nitrogen can be spectrally resolved. These lines are temperature sensitive, so

temperature within cirrus clouds can be retrieved. Raman scattering of the transmitted 532 nm radiation from nitrogen (607 nm radiation) is also collected. Raman scattered returns from nitrogen (at 387 nm) and water vapor (at 407 nm) are also collected from the transmitted 355 nm beam. The ratio of the elastically scattered 355 or 532 nm radiation to the corresponding Raman scattered return at 387 or 607 nm, allows for the direct measure of the aerosol backscatter ratio. The ratio of the 407 nm return to the 387 nm return yields a relative water vapor profile. This can be calibrated to yield an absolute measurement of the tropospheric water vapor profile.

AT Lidar Data Products

- Aerosol backscatter at 1064, 532, and 355 nm
- Aerosol depolarization at 532 nm
- Aerosol backscatter and extinction at 532 and 355 nm
- Stratospheric aerosol and temperature
- Tropospheric water vapor
- Tropospheric temperature (includes within clouds)

AT Lidar Parameters

- Laser wavelengths: 1064, 532, and 355 nm at 50 Hz
- Optical returns: 1064, 532, 607, 355, 387, and 407 nm
- Vertical resolution (raw signal): 15 m
- Telescope: 36-in Newtonian

Principal Investigator

Thomas J. McGee
NASA's Goddard Space Flight Center
Thomas.J.McGee@nasa.gov

AT Lidar Team Members

Paul Newman
NASA's Goddard Space Flight Center

Grant Sumnicht
Science Systems and Applications, Inc.

Laurence Twigg
Science Systems and Applications, Inc.

Co-Investigator

Jens Reichardt
German Weather Service

Science Question for Future Campaigns

- What determines the formation of cirrus cloud particles as a function of temperature within the cloud?

References

Beyerle, G., M.R. Gross, D.A. Haner, N.T. Kjome, I.S. McDermid, T.J. McGee, J.M. Rosen, H.J. Schaefer, and O. Schrems, 2001: STRAIT'97: An aerosol lidar and backscatter sonde intercomparison campaign at Table Mountain Observatory during February–March 1997, *J. Atmos. Sci.*, **58**, 1275–1287.

CPL

Goddard Lidar Observatory for Winds



The ER-2 CPL system in flight configuration.

Key CPL Facts

- Heritage: Cloud Lidar System (CLS)
- ER-2 airborne lidar for cloud and aerosol profiling. Provides cloud/layer boundary, depolarization ratio, optical depth, and extinction ratios.
- Participated in more than a dozen field campaigns, including SAFARI-2000, CRYSTAL-FACE, and TC4.
- Nominal Flight Characteristics: 65,000 ft (20 km), above 94 percent of Earth's atmosphere. Nadir viewing, 9 h duration time with 5 GB storage.
- CPL URL: <http://cpl.gsfc.nasa.gov>

Description

The effect of clouds and aerosols on regional and global climate is of great scientific importance. Long-standing elements of the NASA climate and radiation science program are field studies incorporating airborne remote sensing and in situ measurements of clouds and aerosol. The CPL system is designed specifically for studying clouds and aerosols using the ER-2 High Altitude Aircraft. Because the ER-2 typically flies at 65,000 ft (20 km), its instruments are above 94% of the Earth's atmosphere, thereby allowing ER-2 instruments to function as spaceborne instrument simulators. The CPL provides a unique tool for atmospheric profiling and

is sufficiently small and low cost to include in multiple instrument missions. Active lidar profiling is especially valuable because the cloud height structure is measured unambiguously, up to the limit of signal attenuation.

CPL Data Products

- Planetary Boundary Layer (PBL) boundaries for aerosols and clouds
- Layer optical depth
- Layer extinction-to-backscatter ratio(s) used
- Layer extinction profile
- Layer transmission profile
- Images of extinction and optical depth
- Depolarization ratio

CPL Parameters

- Vertical Resolution: 30 m
- Horizontal Resolution: 200 m
- Wavelengths: 1064, 532, and 355 nm
- Laser Repetition Rate: 5000 Hz
- Laser Pulse Energy: 50 microJ at 1064 nm; 25 microj at 532 nm; 50 microj at 355nm
- Total Power: 60 W to 1200 W
- Weight: 50 kg to 110Kg
- FOV: 100 μ rad

Principal Investigator

Matthew J. McGill
NASA's Goddard Space Flight Center
Matthew.J.McGill@nasa.gov

Co-Investigators

William Hart
Science Systems and Applications, Inc.

Dennis Hlavka
Science Systems and Applications, Inc.

Scientific Questions for Future Campaigns

- What are the particle sizes within clouds?
- What is the effect of multiple scattered signals on estimates of extinction-to-backscatter and optical depth?

Future Campaigns

- CALIPSO validation flights
- Yearly campaigns supporting various Earth Science missions or experiments.

References

McGill, M.J., D.L. Hlavka, W.D. Hart, J.D. Spinhirne, V.S. Scott, and B. Schmid, 2002: The cloud physics lidar: Instrument description and initial measurement results. *Appl. Opt.*, 41, 3725–3734.

McGill, M.J., D.L. Hlavka, W.D. Hart, E.J. Welton, and J.R. Campbell, 2003: Airborne lidar measurements of aerosol optical properties during SAFARI-2000. *J. Geophys. Res.*, 108, doi: 10.1029/2002JD002370.

McGill, M.J., L. Li, W.D. Hart, G.M. Heymsfield, D.L. Hlavka, P.E. Racette, L. Tian, M.A. Vaughan, and D.M. Winker, 2004: Combined lidar-radar remote sensing: Initial results from CRYSTAL-FACE. *J. Geophys. Res.*, 109, D07203, doi: 10.1029/2003JD004030.

GLOW

Goddard Lidar Observatory for Winds



The GLOW mobile Doppler lidar measures wind profiles from surface into the stratosphere. The two-axis scanner (on the roof) allows full-sky scanning of the lidar.

Key GLOW Facts

- Heritage: Double Edge Wind Lidar, and ZEPHYR New Millennium Program.
- GLOW is a mobile system for determining vertical profiles of wind from the Doppler shifted frequency of the laser signal scattered back towards the lidar. Profiles of wind speed and direction are produced.
- GLOW participated in several field experiments including the International H₂O Project (IHOP), the Groundwinds, NH Validation Experiment and HARGLO.
- GLOW currently operates at the Howard University Research Facility in Beltsville, Maryland as part of a three-year NASA-funded Wind Lidar Science program.
- Nominal Field Configuration: Truck based scanning Doppler lidar designed for day and night operation. Step stare scanning in azimuth (0–360 deg) with fixed elevation angle (0–90 deg).
- GLOW URL: <http://glow.gsfc.nasa.gov>

Description

Tropospheric winds are recognized as the single most important measurement for improved weather forecasting. Winds are also required for a variety of research applications

requiring knowledge of the atmospheric dynamics for process and transport studies. The Goddard Lidar Observatory for Winds (GLOW) is a mobile wind lidar system utilizing direct detection Doppler lidar techniques for measuring wind profiles up to 35 km. The GLOW mobile lidar system has a twofold purpose: First, to provide wind profile measurements from the surface into the stratosphere for use in scientific measurement programs, and second, as a testbed for validating the performance of new technologies and measurement techniques proposed for use in future spaceborne applications. Future plans include spaceborne observation of global winds as well ground and airborne measurements of winds for investigation of mesoscale dynamics and atmospheric processes.

GLOW Data Products

- Range resolved scans (PPI, RHI) of radial wind speed
- Vertical Profiles of u, v, w component winds and wind speed and direction
- Coverage: 0.1 to 30 km
- Minimum range resolution: 40 m
- Accuracy : 0.5 to 3 m/s

GLOW Parameters

- Laser Wavelengths: 1064 and 355 nm
- Laser Energy/Pulse: 50 mJ @ 355nm
- Pulse Repetition Rate: 50 Hz
- Telescope/scanner aperture: 45 cm
- FOV: 0.2 mrad

Principal Investigator

Bruce Gentry
NASA's Goddard Space Flight Center
Bruce.M.Gentry@nasa.gov

GLOW Team Members

Tulu Bacha
Howard University

Huailin Chen
Science Systems and Applications, Inc.

Belay Demoz
Howard University

Gerry McIntire
SGT

Demetrius Venable
Howard University

Kevin Vermeesh
Science Systems and Applications, Inc.

Science Questions for Future Campaigns

- How do clouds and aerosols impact the molecular Doppler lidar wind measurement?
- Can wind profile observations through the tropopause improve understanding of tropospheric/stratospheric exchange?

References

- Demoz, B., C. Flamant, T. Weckwerth, D. Whiteman, F. Fabry, P. Di Girolamo, D. Miller, B. Geerts, W. Brown, G. Schwemmer, B. Gentry, W. Feltz, and Z. Wang, 2006: The dryline on 22 May 2002 during IHOP_2002: Convective-scale measurements at the profiling site. *Mon. Wea. Rev.*, **134**, 294–310.
- Gentry, B. and H. Chen. “Performance Validation and Error Analysis for a Direct Detection Molecular Doppler Lidar,” invited paper, SPIE Third International Asia-Pacific Environmental Remote Sensing Conference, Hangzhou, 2002.
- Gentry, B. and H. Chen. “Profiling tropospheric winds with the Goddard Lidar Observatory for Winds (GLOW),” Proceedings of the 21st International Laser Radar Conference, Quebec City, Canada, 2002.
- Gentry, B., H. Chen. S. X. Li, 2000: Wind measurements with a 355 nm molecular Doppler lidar. *Opt. Lett.*, **25**, 1231–1233.
- Gentry, B., H. Chen. S. X. Li, S. Mathur, J. Dobler, and W. Hasselbrack. “Tropospheric Wind Profiles Obtained with the GLOW Molecular Doppler Lidar during the 2002 International H₂O Project,” International Symposium on Tropospheric Profiling, Leipzig, Germany, 2003.
- Gentry, B., 2001: “Advances in Direct Detection Doppler lidar technology and techniques”, *Proceedings of the 2001 International Geoscience and Remote Sensing Symposium*, Sydney, Australia, July 9–14, 2001.
- Koch, S., C. Flamant, J. Wilson, B. Gentry, B. Jamison, 2007: An atmospheric solution observed with Doppler radar, differential absorption lidar, and a molecular Doppler lidar. *J. Atmos. Oceanic Technol.*, **25**, 1267–1287.
- Korb, C. L., B. Gentry, S. Li, 1997: Edge technique Doppler lidar wind measurements with high vertical resolution. *Appl. Opt.*, **36**, 5976–5983.
- Korb, C. L., B. Gentry, S. Li, C. Flesia, 1998: Theory of the double-edge technique for Doppler lidar wind measurement. *Appl. Opt.*, **37**, 3097–3104.

HARLIE

Holographic Airborne Lidar Instrument Experiment

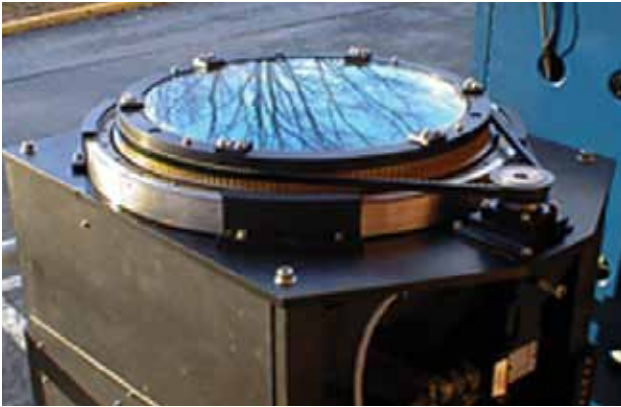

Photo of HARLIE Transceiver and 40.6 cm HOE.

Key HARLIE Facts

- A unique scanning lidar based on a rotating holographic telescope, to measure atmospheric profiles of aerosol, boundary layer & cloud top heights, cloud bottom heights and wind profiles with high temporal resolution.
- Participated in several field campaigns including IHOP, ARMIOp2000, and HARGLO.
- Nominal Deployment Characteristics:
- Surface: Housed in an environmentally controlled mobile trailer.
- Aircraft: Transceiver mounted on a frame a few cm from a viewing window provides a 200 μ rad FOV and sweeps out 45-degree cone.
- HARLIE URL: <http://harlie.gsfc.nasa.gov/>

Description

HARLIE measures cloud and aerosol structure and dynamics via laser backscatter in three dimensions. Utilizing a unique conical scanning holographic telescope and a diode pumped solid-state infrared laser, this compact high-performance lidar fits into low- to medium-altitude aircraft as well as in a portable ground-based environmental housing for relatively low cost field experiment deployments. HARLIE will also be used to test concepts for an airborne direct detection wind lidar that could one day be used for spaceborne applications. It uses a 40-cm diameter by 1-cm thick Holographic Optical Element (HOE) as the receiver collecting and focusing aperture. It has a 45-degree diffraction angle and a 1-m focus normal to its surface. It is continuously scanned up to 30 rpm, and can also operate in step-and-stare or static modes.

HARLIE Data Products

- Aerosol Backscatter Profiles: 20 m and 100 ms resolution
- Boundary Layer and Cloud Heights: ± 20 m, 100 ms intervals
- Cloud Fraction vs Altitude
- Wind Profiles: ± 2 m/s, 200 m vertical, 15 min time resolution

HARLIE Parameters

- Wavelength: 1064 nm
- Laser Power: 200 μ J
- LaserPulse Rate: 5 Khz
- Scan Modes: Continuous up to 30 rpm, point and stare, 8-position step-stare, sector, and 3-D scanning

HARLIE Principal Investigator

Bruce Gentry
NASA's Goddard Space Flight Center
Bruce.M.Gentry@nasa.gov

HARLIE Team/Investigators

Belay Demoz
Howard University

Tim Kane
Pennsylvania State University

Sangwoo Lee
Science Engineering Services

Gerry McIntire
SGT

David O. Miller
Pennsylvania State University

Geary K. Schwemmer
Science Engineering Services

Thomas Wilkerson
Utah State University

Science Questions for Future Campaigns:

- What are atmospheric profiles of backscattered aerosols during daytime?
- How do gravity waves interact with and organize convection in the Planetary Boundary Layer?
- How important are convectively driven gravity waves in transferring momentum and energy to the free troposphere?

Upcoming Field Campaigns

HARLIE is currently on loan to the Pennsylvania State University where it is being used by Professor Tim Kane and his graduate student David Miller to study Boundary Layer convection and dynamics.

References

Berkoff, T.A., D.N. Whiteman, R.D. Rallison, G.K. Schwemmer, L. Ramos-Izquierido and H. Plotkin, 2000: Remote detection of Raman scattering by use of a holographic optical element as a dispersive telescope. *Optics Letters*, **25**, 1201–1203.

Demoz, B., C. Flamant, T. Weckwerth, D. Whiteman, F. Fabry, P. Di Girolamo, D. Miller, B. Geerts, W. Brown, G. Schwemmer, B. Gentry, W. Feltz, and Z. Wang, 2006: The dryline on 22 May 2002 during IHOP_2002: Convective-scale measurements at the profiling site. *Mon. Wea. Rev.*, **134**, 294–310.

Schwemmer, G., 1993: "Conically scanned holographic LIDAR telescope," *NASA Tech Briefs*, October 1993, 61–62.

Schwemmer, G., T. Wilkerson, and D. Guerra, 1998: "Compact scanning lidar systems using holographic optics," in *Optical Remote Sensing for Industry and Environmental Monitoring*, U. N. Singh, H. Hu, G. Wang, Eds., *Proc. SPIE*, **3504**, Beijing, China, 14–17 September 1998, 51–59.

Schwemmer, G., J. A. Sanders, D. V. Guerra, D. O. Miller, and S. E. Moody, 2001: "Ground based operational testing of holographic scanning lidars," in *Advances in Laser Remote Sensing*, A. Dabas, C. Loth and J. Pelon, Eds., Ecole Polytechnique, France, 69–72.

KILT

Kiritimati Island Lidar Trailer



KILT was deployed at the Jet Propulsion Laboratory's (JPL) Table Mountain Facility North of Los Angeles, California. The power generating solar panels and windmill are visible in this picture.

Key KILT Facts

- KILT is an autonomous, elastic backscatter/depolarization lidar instrument for the measurement of cloud parameters from a remote location. The instrument will generate a cirrus cloud climatology in the tropical Pacific, above Kiritimati (also known as “Christmas”) Island (2°N lat).
- Nominal field configuration: The system is mobile and uses solar panels and a windmill to generate the power necessary to operate the instrument. KILT has been in operation in the field since 2004.

Description

In the current environment of concern about global warming, climate change, and ozone depletion/recovery, measurements in the tropics, within $\pm 5^\circ$ of the equator are limited, sporadic, or both. Routine observations in this region are therefore of great benefit to many programs including those dealing with atmospheric chemistry, dynamics and radiation, and validating satellite instruments. Kiritimati Island is located in the equatorial dry zone of the central Pacific where significant rainfall only occurs during the warm phase of the Southern Oscillation. The thick, persistent cloud cover typical in the convectively active western Pacific is absent in the region of Kiritimati Island thus providing the clear skies required for the atmospheric observations to be made by KILT.

There is a clear need for long-term, high spatial resolution, depolarization lidar observations of cirrus cloud layers near the equator. KILT is an autonomous, eye-safe instrument. It transmits two laser wavelengths, 1064 and 532 nm, at a 2,500 Hz pulse repetition frequency, at a total energy of 200 μJ per pulse. The 532 nm return is separated into parallel and perpendicular polarizations to measure the depolarization caused by scattering from irregular particles (ice in cirrus clouds). Data will be transferred via satellite phone to a server at Table Mountain.

KILT Data Products

- Aerosol backscatter at 532 and 1064 nm
- Aerosol depolarization at 532 nm

KILT Parameters

- Laser wavelengths: 1064 and 532 nm at 2.5 kHz
- Optical returns: 1064, 532 nm (parallel and perpendicular)
- Vertical resolution (raw signal): 15 m
- Telescope: 12-in Cassegrain

Principal Investigators

Thomas J. McGee
NASA's Goddard Space Flight Center
Thomas.J.McGee@nasa.gov

I. Stuart McDermid
NASA's Jet Propulsion Laboratory, Table Mountain Facility

Co-Investigators

Thierry LeBlanc
NASA's Jet Propulsion Laboratory

Grant Sumnicht
Science Systems and Applications, Inc.

Laurence Twigg
Science Systems and Applications, Inc.

Science Questions for Future Campaigns

- What is the cirrus cloud climatology above an equatorial Pacific site?
- What is the frequency and extent of sub-visible cirrus clouds? Is Kiritimati Island suitable for a long-term NDSC facility?

MABEL

Multiple Altimeter Beam Experimental Lidar



MABEL being installed in the ER-2 nose.

Description

The Multiple Altimeter Beam Experimental Lidar (MABEL) is a new instrument being developed in support of the ICESat-2 mission. The ICESat-2 mission is critically dependent on making cross-track measurements of surface slope. This is accomplished by using multiple independent beams, measured simultaneously, to profile the surface. Moreover, to enable this measurement concept, ICESat-2 is embracing a new approach to surface altimetry measurements by using high repetition rate, low pulse energy lasers and photon-counting detection.

Because there are many engineering and science trades made possible by using the multiple beam photon-counting approach, it is essential to have an airborne simulator instrument that can be used to demonstrate the measurement concept. MABEL is an airborne demonstrator instrument that has enough design flexibility to permit exploration of engineering and science trade spaces to inform and validate the ICESat-2 instrument design. Initial plans call for deployment on the high-altitude ER-2 aircraft, with eventual adaptation to the Global Hawk unmanned platform.

The design for MABEL is two wavelength (532 and 1064 nm) with 16 beams at 532 nm and 8 beams at 1064 nm. Each transmit beam produces a 2-m diameter footprint on the surface, centered on a 4-m diameter field of view. Fiber-optic arrays coupled to the transmit and receive telescopes determine the viewing geometry. The fiber arrays, arranged similar to a telephone switchboard, permit selection of specific viewing geometry that can be varied in increments of 20 m across a 2-km swath.

MABEL Instrument Parameters

- Wavelength: 532 and 1064 nm.
- Laser repetition rate: 5 to 25 kHz
- Laser energy (per beam): $\sim 5 \mu\text{J}$ at 532 nm; $\sim 5 \mu\text{J}$ at 1064 nm.
- Number of beams: up to 16 at 532 nm, up to 8 at 1064 nm.
- Telescope diameter: 6 inches
- Total Power: <1500 watts
- Weight: <120 kg
- FOV: 200 microradians
- 30 m vertical resolution

Principal Investigator

Matthew McGill
 NASA's Goddard Space Flight Center
matthew.j.mcgill@nasa.gov

Future Plans

- Provide demonstration measurements in support of ICESat-2 for 2011 and beyond.
- Provide validation measurements in support of ICESat-2.

The NASA Micro Pulse Lidar Network (MPLNET)

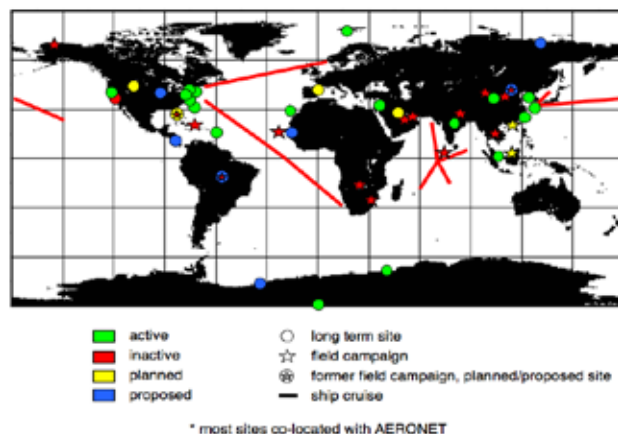

Key MPLNET Facts

- Heritage: GSFC Director's Discretionary Fund (DDF)
- Nominal field configuration: Global ground-based sites in the NASA Micro-Pulse Lidar Network (MPLNET).
- Instruments are compact and eye-safe lidars capable of profiling the vertical structure of aerosols and clouds up to 20+ km.
- The instrument design was engineered for deployments to remote field locations requiring continuous lidar observations.
- MPL URL: <http://mplnet.gsfc.nasa.gov>

Description

The Micro Pulse Lidar instrument was developed at GSFC during the early 1990s and is now a commercial product. MPL is a unique eye-safe lidar system created to autonomously measure aerosol and cloud vertical structure. The NASA Micro Pulse Lidar Network (MPLNET) is a federated network of MPL systems designed to profile aerosol and cloud vertical structure continuously, day and night in an autonomous fashion, over long time periods required to contribute to climate change studies and provide ground validation for models and satellite sensors in the NASA Earth Observing System (EOS). At present, there are 18 active sites worldwide, and three more in the planning stage. Numerous temporary sites have been deployed in support of various field campaigns, and two more are planned in 2010. Most MPLNET sites are co-located with sites in the NASA Aerosol Robotic Network (AERONET) to provide both column and vertically resolved aerosol and cloud data. The combined measurements are able

to produce quantitative aerosol and cloud products, such as optical depth, sky radiance, vertical structure, and extinction profiles. Over the past 10 years, MPLNET measurements have been conducted from urban locations, remote areas near desert regions, biomass burning zones, ships at sea, and even the South Pole. Data collected from around the globe has led to an increased understanding of aerosol properties and transport, aerosol-cloud interactions, and polar cloud and snow properties. MPLNET also serves as a ground-calibration network for several NASA satellite programs. MPLNET data, publications, and more information on the project are available at <http://mplnet.gsfc.nasa.gov>.

MPLNET Data Products

- Backscatter lidar signals from surface to 20+ km (1 min, 75 m resolutions)
- Aerosol, cloud, and planetary boundary layer heights, vertical feature mask
- Aerosol and cloud properties

MPL Instrument Parameters

- Laser wavelength: 523, 527, or 532 nm
- Laser pulse energy: 5–10 μ J
- Pulse repetition rate: 2500 Hz
- Telescope: 7–8-in Cassegrain
- Vertical resolution: 15–300 m
- Typical data rate: 1 s to 1 min

Principal Investigator

Ellsworth J. Welton
 NASA's Goddard Space Flight Center
Ellsworth.J.Welton@nasa.gov

Co-Investigators

Timothy A. Berkoff
 University of Maryland, Baltimore County

James R. Campbell
 UCAR Visiting Scientist, Naval Research Laboratory
 Monterey

Brent N. Holben
NASA's Goddard Space Flight Center

Si-Chee Tsay
NASA's Goddard Space Flight Center

Scientific Questions for Future Observations

- What are the altitudes of absorbing aerosol layers?
- Can aerosol transport models accurately determine aerosol height?
- How does boundary layer height impact aerosol transport and surface pollution levels?
- How do dust, smoke, and pollution aerosols effect cloud formation and precipitation?
- What are the optical properties of thin polar clouds and polar stratospheric clouds (PSC)?



MPL data system and instrument.

RASL

Raman Airborne Spectroscopic Lidar



University of Maryland, College Park graduate student Scott Rabenhorst is shown at the RASL control panel during onboard measurements.

Key RASL Facts

- Heritage: GSFC Instrument Incubator Program (IIP) 2001
- Designed to measure water vapor mixing ratio, aerosol and backscatter, extinction and depolarization, and liquid cloud properties.
- RASL's first flights occurred in the summer of 2007 demonstrating the first simultaneous measurements of water vapor mixing ratio and aerosol backscatter and extinction; a combination that can add insight into cloud growth processes. In addition, cloud droplet size distribution measurements were demonstrated.

Description

RASL can perform day and nighttime measurements of water vapor mixing ratio, aerosol backscatter coefficient, extinction, depolarization, and extinction to backscatter ratio. Cloud liquid water, droplet radius and number density retrievals are available at night. RASL is the only airborne lidar system to combine measurements of water vapor, aerosol backscatter, extinction, and depolarization. In addition, research mode measurements of liquid cloud properties are available. It also possesses a great advantage in eye safety over existing airborne water vapor lidar systems.

RASL Data Products

- Water vapor mixing ratio
- Aerosol scattering ratio
- Aerosol extinction
- Aerosol backscattering coefficient
- Aerosol extinction/backscatter ratio
- Aerosol depolarization
- Cloud liquid water, droplet radius, number density
- Rotational Raman temperature (added since the 2007 flights)

RASL Parameters

- Laser wavelength: 355 nm
- Laser pulse energy: 350 mJ at 50 Hz
- Laser pulse length: 7 ns
- FOV: 25 μ rad, 0.6 m aperture
- Optical channels: 354.7, 375, 386.7, 403.2, and 407 nm

Principal Investigator

David N. Whiteman
NASA's Goddard Space Flight Center
David.N.Whiteman@nasa.gov



The RASL aircraft, a Beechcraft King Air B200, prepares for the first engineering flight.

RASL Team Members/Co-Investigators

Martin Cadirola
Electronic Systems, Ecotronics, Inc.

Gerry McIntire
SGT

Kurt Rush
NASA's Goddard Space Flight Center

Igor Veselovskii
University of Maryland, Baltimore County

Wayne Welch
Welch Mechanical Designs, LLC

Science Goals for Future Campaigns

- Quantify the spatial variation of boundary-layer water vapor, aerosols, and clouds in mesoscale systems, such as fronts and bores.
 - Study the relationship of relative humidity on aerosol extinction within the boundary layer.
 - Investigate the relationship of aerosol extinction and cloud properties, such as liquid water content, droplet radius, and number density.
- If flown in an upward looking configuration or from high altitude aircraft looking downward, quantify cirrus cloud optical depth, equivalent particle size, and ice water content.

References

Whiteman, D.N., G. Schwemmer, T. Berkoff, H. Plotkin, L. Ramos-Izquierdo, and G. Pappalardo, 2001: Performance modeling of an airborne Raman water vapor lidar. *Appl. Opt.*, **40**, 375–390.

Whiteman, D.N., K. Rush, S. Rabenhorst, W. Welch, M. Cadirola, G. McIntire, F. Russo, M. Adam, D. Venable, R. Connell, I. Veselovskii, R. Forno, B. Mielke and B. Stein, T. Leblanc, S. McDermid, and H. Vömel, “Airborne and ground-based measurements using a high-performance Raman lidar.” Accepted to JTECH.

Whiteman, D.N., I. Veselovskii, M. Cadirola, K. Rush, J. Comer, J. Potter, R. Tola, 2007: Demonstration measurements of water vapor, cirrus clouds, and carbon dioxide using a high-performance Raman lidar, *J. Atmos. Ocean. Tech.*, **24**, 1377–1388.

STROZ LITE

Stratospheric Ozone Lidar Trailer Experiment

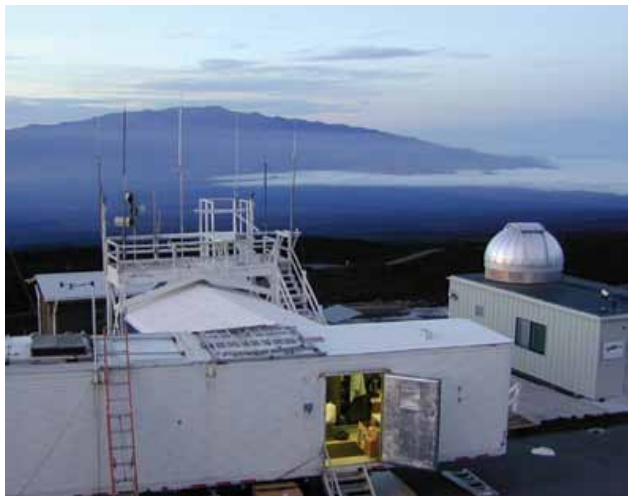

The STROZ LITE Trailer deployed at the Mauna Loa Observatory in August 2002. Mauna Kea is visible in the background.

Key STROZ LITE Facts

- Heritage: Originally designed for stratospheric ozone, modified to include temperature, aerosols, and tropospheric water vapor.
- A differential absorption, elastic and inelastic backscatter lidar instrument that returns vertical profiles of ozone, temperature, and aerosol parameters in the stratosphere, and a vertical profile of water vapor in the troposphere.
- The lidar has been involved in 18 national and international campaigns supporting satellite validation, aircraft campaigns, and NDSC validation campaigns.
- Nominal field configuration: The system is mobile and is housed in a large, environmentally controlled shipping container.

Description

The STROZ LITE lidar uses two lasers to generate the two wavelengths that are transmitted into the atmosphere: an XeCl excimer laser, emitting at 308 nm; and another laser to transmit near 350 nm with a spectrally narrow emission line. Ozone is extracted using a Differential Absorption (DIAL) technique: two wavelengths are transmitted into the atmosphere. One is strongly absorbed by ozone, while the other is not absorbed. Ozone can then be deduced from the difference in slope between the lidar returns at the

two transmitted wavelengths. In addition to collecting the backscatter signal from each of these transmitted wavelengths, STROZ LITE collects several inelastic returns from Raman scattering from N_2 and H_2O . The STROZ LITE instrument was the first to develop the Raman scatter differential absorption technique for the measurement of ozone profiles in the presence of heavy aerosol loadings. This was put into place shortly after the eruption of Mt. Pinatubo in 1991. The success of this technique resulted in a recommendation from the NDSC Steering Committees that all ozone lidar instruments within the NDSC should incorporate the Raman channels needed for the Raman DIAL technique.

STROZ LITE Data Products

- Aerosol backscatter and extinction at 355 nm, troposphere
- Stratospheric and mesospheric temperature
- Tropospheric water vapor
- Stratospheric ozone

STROZ LITE Parameters

- Laser wavelengths: 308 nm at 200Hz; 355 nm at 50 Hz
- Optical returns: 308, 332, 355, 387, and 407 nm
- Vertical resolution (raw signal): 15 m
- Telescope: 30-in Dall-Kirkham

Principal Investigator

Thomas J. McGee
NASA's Goddard Space Flight Center
Thomas.J.McGee@nasa.gov

Co-Investigators

Paul Newman
NASA's Goddard Space Flight Center

Grant Sumnicht
Science Systems and Applications, Inc.

Laurence Twigg
Science Systems and Applications, Inc.

Science Questions for Future Campaigns

- Has ozone begun its recovery from the losses because of Cl destruction?
- What are the variability and abundance of water vapor just above the troposphere?

References

Bailey, P.L., D.P. Edwards, J.C. Gille, L.V. Lyjack, S.T. Massie, A.E. Roche, J.B. Kumer, J.L. Mergenthaler, B.J. Connor, M.R. Gunson, J.J. Margitan, I.S. McDermid, and T.J. McGee, 1996: Comparison of Cryogenic Limb Array Etalon Spectrometer (CLAES) ozone observations with correlative measurements. *J. Geophys. Res.*, **101**, 9737–9756.

THOR

cloud Thickness from Offbeam Returns

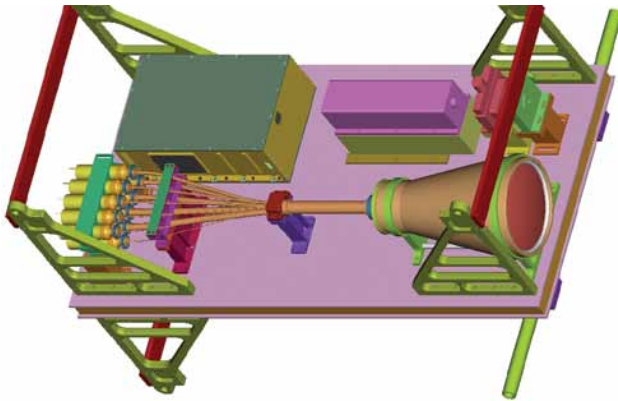

THOR digital image courtesy of Welch Mechanical Designs, LLC (P3 optical bench configuration).

Key THOR Facts

- Heritage: 1996–2000 DDF
- Off-beam lidar using pulsed laser beam to measure diffusing wave propagation in dense clouds to determine optical and geometrical properties. A unique focal plane consists of 250,000 fiber filaments arranged into eight annular rings.
- Instrument validation campaign completed in 2002 over the DOE ARM site in northern Oklahoma.
- Nominal flight characteristics: 5 km above cloud tops; duration typically 8 h.
- THOR URL: <http://climate.gsfc.nasa.gov/thor>

Description

The physical thickness of a cloud layer, and sometimes multiple cloud layers, can be estimated from the time delay of off-beam returns from a pulsed laser source illuminating one side of the cloud layer. In particular, the time delay of light returning from the outer diffuse halo of light surrounding the beam entry point, relative to the time delay at beam center, determines the cloud physical thickness. The delay combined with the pulse stretch gives the optical thickness. The halo method works best for thick cloud layers, typically optical thickness exceeding 2, and thus complements conventional

lidar, which cannot penetrate thick clouds. The THOR System flies on the NASA P3, and measures the halo timings from several kilometers above the cloud top, at the same time providing conventional lidar cloud top height. A refractive telescope with approximately a 7.5-in (19.05-cm) aperture is used to gather the returned light and collect it into a custom-designed fiber optic bundle. The fiber optic bundle routes specific sections of the light, focused by the telescope, into 10 Hamamatsu detectors.

THOR Data Products

- Cloud top and cloud base height
- Vertical scattering extinction profile
- Optical thickness
- Sea ice thickness
- Sea ice scattering and extinction profile

THOR Parameters

- Laser wavelength: 540 nm
- FOV: 6°
- Laser pulse energy: 200 μ J
- Laser pulse rate: 1 kHz

Principal Investigator

Robert F. Cahalan
NASA's Goddard Space Flight Center
Robert.F.Cahalan@nasa.gov

Co-Investigators

Matthew J. McGill
NASA's Goddard Space Flight Center

THOR Team Members

Matthew J. McGill
NASA's Goddard Space Flight Center

Luis A. Ramos-Izquierdo

NASA's Goddard Space Flight Center

Tamas Varnai

University of Maryland Baltimore County

Wayne Welch, Mechanical Engineer

Welch Mechanical Designs, LLC

Science Questions for Future Campaigns

- How does sea ice thickness vary for different ice types, locations, and seasons?
- How will small-scale variations seen by THOR affect Cryosat estimates of sea ice thickness?"?
- What is the vertical profile of cloud scattering extinction, particle size, and absorption?

TWiLiTE

Tropospheric Wind Lidar Technology Experiment

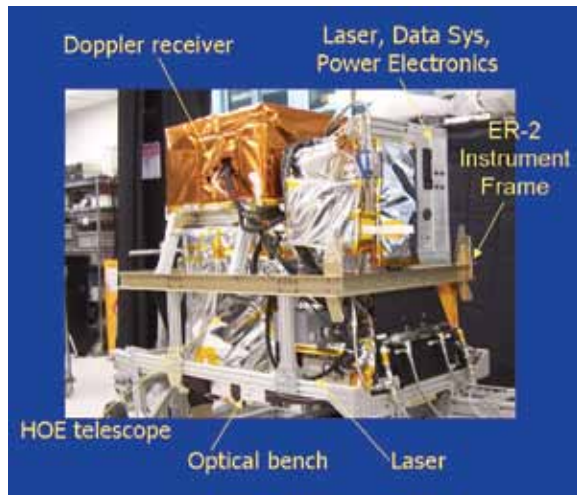

The Tropospheric Wind Lidar Technology Experiment (TWiLiTE) lidar configured for flight on the NASA ER-2.

Key TWiLiTE Facts

- Heritage: Double Edge Wind Lidar, GLOW, ESTO Instrument Incubator Program
- An autonomous airborne Doppler lidar system for measuring vertical profiles of wind from the Doppler shifted frequency of the laser signal scattered back towards the instrument by air molecules.
- Demonstrates key technologies needed for space-based Global Tropospheric Wind Mission
- In fiscal years 2009 and 2010, test flights on the NASA ER-2 demonstrated key functions of the instrument. Additional flights on the ER-2 are planned in the early fiscal year 2011. The instrument will then be reconfigured to fly on the NASA Global Hawk as part of the Hurricane and Severe Storm Sentinel (HS3) Earth Venture Mission.
- Nominal Field Configuration: Airborne scanning Doppler lidar system designed to operate autonomously on NASA high altitude research aircraft including the WB-57, ER-2 and Global Hawk. Step stare scanning in azimuth (0–360 degrees) with 45-degree elevation angle.

Description

The TWiLiTE Doppler lidar measures vertical profiles of wind by transmitting a short laser pulse into the atmosphere, collecting the laser light scattered back to the lidar by air molecules and measuring the Doppler shifted frequency of that light. The magnitude of the Doppler shift is proportional

to the wind speed of the air in the parcel scattering the laser light. TWiLiTE was developed with funding from the Earth Science Technology Office's Instrument Incubator Program (IIP). The primary objectives of the TWiLiTE program are twofold: First, to advance the development of key technologies and subsystems critical for a future space based Global Wind Sounding Mission, as recommended by the National Research Council in the recent Decadal Survey for Earth Science and second, to develop for the first time a fully autonomous airborne Doppler wind lidar instrument to demonstrate tropospheric wind-profile measurements from a high-altitude, downward-looking, moving platform to simulate spaceborne measurements.

TWiLiTE Data Products

- Range resolved conical scans of radial wind speed
- Vertical Profiles of u,v,w component winds, and wind speed and direction
- Coverage: 20 km to the surface
- Nominal vertical resolution: 250 m
- Accuracy : 0.5 to 3 m/s

TWiLiTE Parameters

- Laser wavelength: 355 nm
- Laser energy/pulse: 35 mJ at 355nm
- Pulse repetition rate: 200 Hz
- Telescope/scanner aperture: 40 cm
- FOV: 0.2 mrad

Principal Investigator

Bruce Gentry
NASA's Goddard Space Flight Center
Bruce.M.Gentry@nasa.gov

TWiLiTE Co-Investigators/ Team Members

Alan Brewer
NOAA Earth System Research Laboratory

Ryan Cargo
Sigma Space, Inc

Huailin Chen
Science Systems and Applications, Inc.

Michael Hardesty
NOAA Earth System Research Laboratory

Bill Hart
Science Systems and Applications, Inc.

Roman Machan
Sigma Space, Inc

Cathy Marx
NASA's Goddard Space Flight Center

Matthew McGill
NASA's Goddard Space Flight Center

Dan Reed
Sigma Space, Inc

Stan Scott
NASA's Goddard Space Flight Center

Geary Schwemmer
Science Engineering Services

Marcos Sirota
Sigma Space, Inc

Shane Wake
NASA's Goddard Space Flight Center

Thomas Wilkerson
Utah State University

John Yorks
Science Systems and Applications, Inc.

Science Questions for Future Campaigns

- Can wind observations in and around a tropical cyclone improve the prediction of hurricane intensity and track?
- Can wind profile observations through the tropopause improve understanding of tropospheric/stratospheric exchange?

References

Gentry, B., M. McGill, G. Schwemmer, M. Hardesty, A. Brewer, T. Wilkerson, R. Atlas, M. Sirota, S. Lindemann and F. Hovis. "The TWiLiTE airborne direct detection Doppler lidar for tropospheric wind profiling", invited paper, Proceedings of the Annual Meeting of the American Meteorological Society, New Orleans, Louisiana, 2008.

Gentry, B., M. McGill, G. Schwemmer, M. Hardesty, A. Brewer, T. Wilkerson, R. Atlas, M. Sirota, S. Lindemann and F. Hovis. "New technologies for direct detection Doppler lidar: Status of the TWiLiTE airborne molecular Doppler lidar project", Proceedings of the 24th International Laser Radar Conference, Boulder, Colorado, 2008.

Gentry, B., M. McGill, G. Schwemmer, M. Hardesty, A. Brewer, T. Wilkerson, R. Atlas, M. Sirota, S. Lindemann and F. Hovis. "Recent advances in Doppler lidar instrument Technology at NASA's Goddard Space Flight Center", IGARSS 2009, Cape Town, South Africa, 2009.

Gentry, B., M. McGill, R. Machan, D. Reed, R. Cargo, D. J. Wilkens, W. Hart, J. Yorks, S. Scott, S. Wake, M. Hardesty, and A. Brewer. "Flight testing of the TWiLiTE airborne molecular Doppler lidar", 25th International Laser Radar Conference, St Petersburg, Russia, 2010.

UAV CPL

Unmanned Aerial Vehicle Cloud Physics Lidar



The NASA Global Hawk aircraft.

Key UAV CPL Facts

- Heritage: ER-2 Cloud Physics Lidar (CPL)
- NASA's first lidar instrument for the new Global Hawk platform
- Nominal flight characteristics: 65,000 ft (20 km), nadir viewing, up to 36-hour duration, real-time command and control, and data downlinking
- URL: <http://cpl.gsfc.nasa.gov>

Description

Based on the success of the ER-2 Cloud Physics Lidar, or CPL (see <http://cpl.gsfc.nasa.gov>), a similar instrument, termed UAV-CPL, has been constructed for use on the Global Hawk unmanned platform. NASA now has two Global Hawks and UAV-CPL is the first lidar to fly on the new aircraft. Global Hawk is a large aircraft, and the UAV-CPL instrument package fits nicely into the nose section.

Data products and data quality will be similar to the current ER-2 CPL instrument. Using the proven ER-2 instrument as a design base has permitted easy and inexpensive construction of the UAV-CPL. The long duration flights possible with the Global Hawk will prove useful in future science campaigns allowing, for example, study of cyclogenesis life cycle from formation up through dissipation. Validation of satellite sensors in regions previously inaccessible by manned aircraft will also be enabled through use of Global Hawk.

The UAV-CPL is a backscatter lidar designed to operate simultaneously at three wavelengths: 1064, 532, and 355 nm. The lidar uses state-of-art technology with a high repetition rate, low pulse energy laser and photon-counting detection. Vertical resolution of the measurements is fixed at 30 m; horizontal resolution is variable but is typically 1 s. Primary instrument parameters are listed below.

UAV-CPL Parameters

- Laser wavelengths: 1064, 532, and 355 nm
- Laser type: solid state Nd:YVO₄
- Laser repetition rate: 5 kHz
- Laser output energy: 50 μJ at 1064 nm, 25 μJ at 532 nm, and 50 μJ at 355 nm
- Telescope: 20-cm diameter, off-axis parabola
- Telescope FOV: 100 μrad, full angle
- Raw data resolution: 1/10 s (30 m × 200 m horizontal)
- Processed data resolution: 1 s (30 m × 200 m horizontal)
- Instrument weight: Approximately 350 lbs
- Duration: Up to 36 h
- Flight altitude: 50,000–60,000 ft

Principal Investigator

Matthew J. McGill
 NASA's Goddard Space Flight Center
Matthew.J.McGill@nasa.gov

Co-Investigators

William Hart
 Science Systems and Applications, Inc

Dennis Hlavka
 Science Systems and Applications, Inc

John Yorks
 Science Systems and Applications, Inc

Science Questions for Future Campaigns

- How are clouds, particularly cirrus and subvisual cirrus, affecting radiative balance?
- How are aerosols transported from the source region to other areas?
- How are clouds and aerosols interacting?

Campaigns

GloPac was the first field campaign for the NASA Global Hawk during Feb – Mar 2010. UAV-CPL is a critical component of the GloPac campaign.

Passive Optical Instrument Systems

ACAM

The Atmospheric Lidar for Validation, Interagency Collaboration and Education

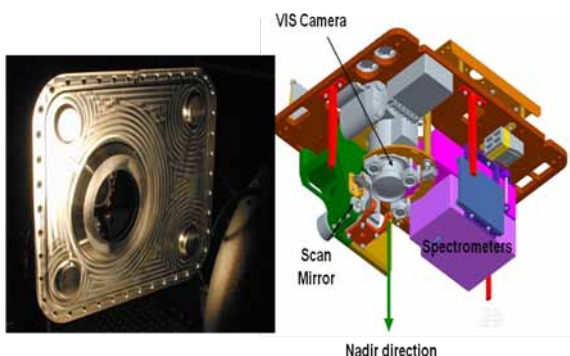

Key ACAM Facts

- High-definition video for cloud and scene identification
- Will fly on NASA's first Global Hawk science mission—GloPac (Spring 2010)
- Previously flown on WB-57 AVE, CRAVE, and NOVICE missions

Description

ACAM is designed to provide high spatial resolution (< 1 km) remote sensing observations of the tropospheric and boundary layer pollutants and aerosols in addition to providing coastal ocean color measurement capabilities. The system is designed to be low-cost and portable while still providing science grade sensitivity in order to support future Air Quality/Ocean science decadal survey geostationary mission planning. This effort will also improve our capabilities to perform in-field absolute calibration of UV/VIS spectrographs and explore absolute radiance transfers with satellite instruments (e.g., OMI) at the sub-5% accuracy level.

ACAM Data Products

- NO₂
- Slant column density of NO₂
- Aerosol index
- Slant column density of O₃
- SO₂
- HCHO

ACAM Parameters

- Sensitivity: 2×10^{-15} molecules/cm²
- Spatial Resolution: 750 m² (UV/VIS), 350 m² (VIS/NIR)

- Spatial Coverage Cross-Track: 15 km at flight altitude of 18 km
- Environmental requirements: Unpressurized compartment
- Instrument Mass: 24 kg
- Dimensions: 40 cm x 30 cm x 27.5 cm
- Power: 400 Watts max
- Data rate: Real-time status and swath averaged NO₂ at 1Hz = 4 Kbps
- Data storage: All data stored on instrument

Principal Investigator

Scott Janz
NASA's Goddard Space Flight Center

Team Members

Matt Kowalewski
University of Maryland, Baltimore County

Robert Frederickson
Sigma Space

Kent McCullough
Science Systems and Applications, Inc.

Science Questions for Future Observations

- What is the evolution of ozone and aerosol through chemical formation and loss, transport, and deposition processes?
- What are the influences of weather in transforming and dispersing emissions, ozone, and aerosol?
- What are the regional budgets for air quality criteria pollutants (O₃, NO_x, SO₂, and aerosol)?
- What are the emission patterns of the precursor chemicals for tropospheric ozone and aerosols?

References

Kowalewski M. and S. Janz, 2009: Remote sensing capabilities of the airborne compact atmospheric mapper, *Proc. SPIE*, 7452.

Brewer

MK IV Spectrophotometer

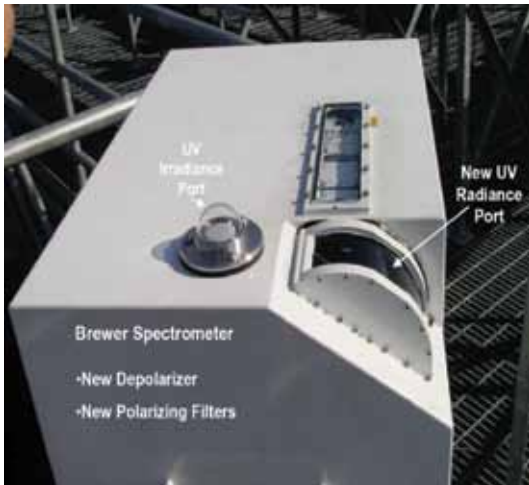

The GSFC modified Brewer spectrophotometer.

Key Facts

A MK IV Brewer Spectrophotometer was purchased primarily for use in the validation of EP-TOMS ozone measurements, for research on new methods to retrieve ozone and SO₂, and for the retrieval of aerosol properties in the ultraviolet range.

Description

The Brewer has the capability to measure the intensity of ultraviolet radiation but was modified to provide for sky radiance measurements by removing unneeded filters from the optical path. The TOMS team replaced them with a set of high quality polarization filters, added a curved quartz window to remove the Fresnel reflection effect, and incorporated a depolarizer. The TOMS team also developed new algorithms to measure the ultraviolet intensity and retrieve ozone and aerosols. The instrument has been well characterized and calibrated in laboratory at the Radiometric Calibration and Development Facility. A unique capability

to measure ozone profiles in both the stratosphere and troposphere was developed. This measurement uses multiple angle observations of the sky radiances throughout the day to determine the ozone profiles every 20 minutes. The method is now being ported to the newly developed Pandora spectrometers.

The GSFC Brewer spectrometer will continue to gather data at Goddard in validation support of the Pandora ozone measurements. In the spring of 2010 the Brewer was shipped to the University of Alaska Fairbanks, where the Brewer is being used to measure ozone at high latitudes as well as to detect trace gas amounts.

Data Products

- Ultraviolet radiation from 286 to 363 nm with a resolution of approximately 0.5 nm.
- Trace gases such as NO₂ in the 335–365 nm range; used to validate OMI NO₂ retrievals.
- Direct sun and zenith sky radiances at medium (327–343 nm) and high (349–363 nm) wavelengths
- Polarized radiance and almucantar measurements
- Polarized Umkehr ozone profiles

Co-Investigators:

Jay Herman
University of Maryland, Baltimore County
Joint Center for Earth Systems Technology

Richard McPeters
NASA's Goddard Space Flight Center

Alexander Cede
University of Maryland
Earth System Science Interdisciplinary Center

EPIC

Earth Polychromatic Imaging Camera on the DSCOVR Project



Drawing of the completed Earth-viewing Deep Space Climate Observatory (DSCOVR) Project (formerly Triana) spacecraft and instruments. EPIC awaits scheduling for launch and deployment to the Earth's Lagrange-1 point.

Key EPIC Facts

- Heritage: An improved version of the Triana spectroradiometer EPIC.
- EPIC is a 10-channel spectroradiometer spanning the ultraviolet to the near-infrared, 317.5–905 nm simultaneously imaging the Earth, from pole to pole and from sunrise to sunset, once per hour.
- Nominal orbit characteristics: Six-month orbit about the Lagrange-1 (L1) point, or neutral gravity point between the Earth and the Sun. The mission is awaiting a launch opportunity.
- EPIC URL: <http://triana.gsfc.nasa.gov/>

Description

EPIC is designed to observe the entire daylight side of the Earth from sunrise to sunset and pole-to-pole using a 10-channel spectroradiometer with 10-km resolution. EPIC has two unique characteristics: (1) the first spaceborne measurements from sunrise to sunset of the entire sunlit Earth, and (2) the first synoptic measurements in both the ultraviolet and visible wavelengths for the entire Earth. These capabilities will allow the determination of diurnal variations of ozone, SO₂, smoke, dust, pollution, water vapor, land and ocean characteristics (ocean color), vegetation index, bidirectional reflectivity (hotspot analysis),

and cloud properties. The applications to human health include knowledge and prediction of ultraviolet exposure and identification of high-exposure high-risk regions, detection and avoidance of smoke plumes from forest fires throughout the daylight hours, detection of floodwaters, and large-scale vegetation changes from drought and land-use changes. The in-storage DSCOVR/EPIC spacecraft and instruments are complete and tested for flight.

EPIC Data Products

- Column ozone: hourly
- Aerosols (dust, smoke, volcanic ash, and sulfate pollution): hourly
- Sulfur dioxide: hourly

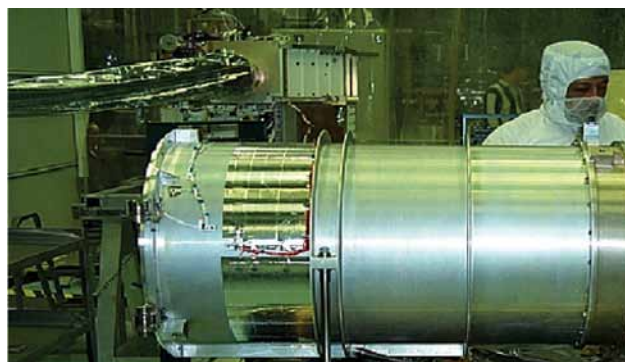

Photograph of EPIC showing the external housing.

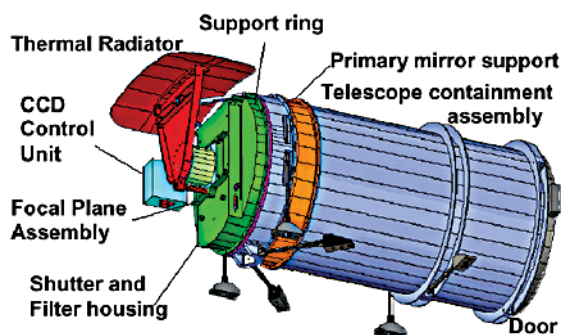

View of the EPIC spectroradiometer showing the external housing for the 30-cm telescope and the thermal radiator attached to the charge coupled device (CCD) housing to keep the CCD about -40°C. The six struts are for attachment to the spacecraft.

- Perceptible water: hourly
- Cloud height, cloud reflectivity, cloud phase (ice or water): every 15 min
- Ultraviolet radiation: every 15 min
- Cloud phase (ice crystal formation)

EPIC Parameters

- Wavelengths: 317.5, 320, 340, 388, 443, 551, 645, 870, and 905 nm
- Spatial resolution: 8–10 km
- Size: 0.4 m by 2 m
- Mass: 75 kg
- Power: 83 W
- Aperture: 30 cm

Principal Investigator

Francisco P.J.Valero
Scripps Institution of Oceanography
fvalero@ucsd.edu

Project Scientist

Jay R.Herman
NASA's Goddard Space Flight Center

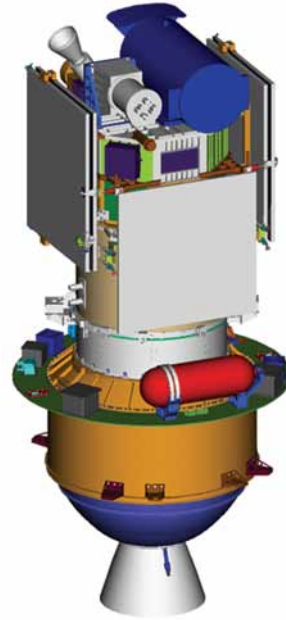

Assembled EPIC spectrometer prior to mounting on the DSCOVR spacecraft.

GeoSpec

Geostationary Spectrograph for Earth and Atmospheric Science Applications

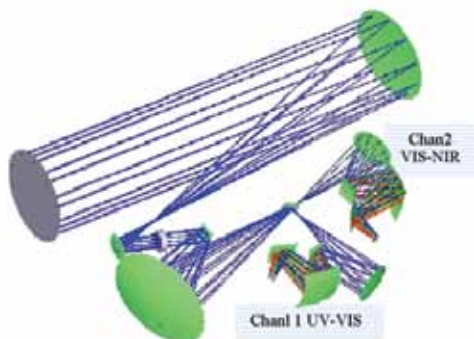

GeoSpec Layout: A 645-mm telescope coupled to a two channel spectrograph; a technology prototype for demonstrating the feasibility of a space-flight instrument.

Key Facts

- Used as baseline design in the Decadal Survey Tier II selection of the Geostationary Coastal and Atmospheric Pollution Events (GEO-CAPE) mission
- High signal-to-noise ratio hybrid
- Complementary Metal Oxide Semiconductor (CMOS) array detectors
- High efficiency broadband LYOT depolarizer
- Diffraction limited optical resolution

Description

GeoSpec is a dual spectrograph operating in the UV/VIS and VIS/Near-Infrared (NIR) wavelength region to measure trace gas concentrations, coastal and ocean pollution events, tidal effects, and aerosol plumes. Channel 1 measures the amount of trace gasses in the Earth's atmosphere. Channel 2 performs measurements important to ocean-land processes and coastal change. The technology demonstration is designed to show the feasibility of atmospheric trace gas retrievals using this type of spectrograph, in addition to testing new detector technology designed to increase the sensitivity in the ultraviolet range. GeoSpec is designed to operate in a laboratory environment and then outdoors at both GSFC and at Washington State University. The flight instrument that would be developed based on this demonstration is intended for a geostationary orbit to measure the variation in target gases throughout the day.

Advantages of a geostationary orbit: Diurnal variations in trace gas constituents can be resolved better than with typical Low-Earth Orbit satellites.

Data Products

- O_3 , SO_2 , and NO_2

GeoSpec Parameters

- Channel 1 spectral range: 300–480 nm
- Channel 2 spectral range: 480–940 nm
- Horizontal resolution:
 - 5 km (atmospheric chemistry)
 - 900 m (coastal ocean processes)
- Scanning time: 1 h (continental scale)
- Weight: 50 kg
- Length: 1 m
- Height: 0.4 m
- Power: 200 W

Principal Investigator

Scott J. Janz
 NASA's Goddard Space Flight Center
Scott.Janz@nasa.gov

Science Questions for Future Campaigns

- What is the evolution of ozone and aerosol through chemical formation and loss, transport, and deposition processes?
- What are the influences of weather in transforming and dispersing emissions, ozone, and aerosol?
- What are the regional budgets for air quality criteria pollutants (O_3 , NO_x , SO_2 , and aerosol)?
- What are the emission patterns of the precursor chemicals for tropospheric ozone and aerosols?

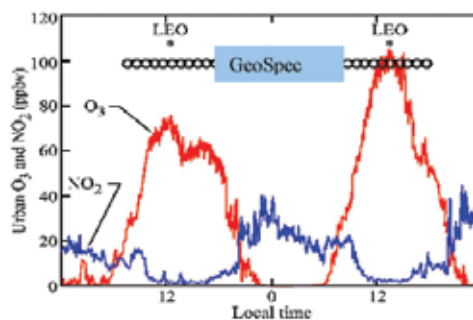

PACS Polarimeter

Passive Aerosol and Cloud Suite Polarimeter

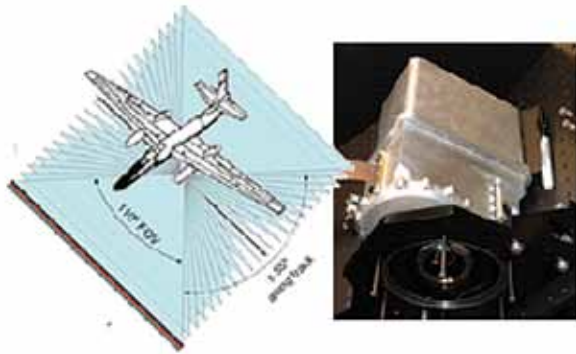

Multi-angle configuration of the PACS VNIR system.

Key PACS facts:

- Wide field of view (FOV) hyperangular polarization with no moving parts.
- Versatile, small, low power system.
- Other wavelength modules can be added from UV to shortwave infrared (SWIR).

Description

The PACS (Passive Aerosol and Cloud Suite) imaging polarimeter is designed as a robust, accurate, multiwavelength, hyperangular polarimeter with no moving parts. The PACS concept has also the advantage of a compact design with internal calibration features. The built-in hyperangular properties of PACS allow for the direct measurement of aerosol and cloud particle's angular scattering properties. As the aircraft moves, each angle and each wavelength are to cover the same region on the ground, producing continuous multi-angle observations for each scene. PACS has a very modular design which allows easy expansion to other wavelength ranges (already designed from 360 to 2250 nm).

PACS is currently designed for the ER-2 aircraft but it can be easily adapted for other platforms and inherently addresses space applications as most of its components have very high technical readiness level (TRL).

PACS Future Data Products

- Aerosol optical thickness and microphysical properties
- Cloudbow phase function in water droplets

- Hyperangular phase function of ice clouds
- Cloud droplet effect radius and variance
- Total column precipitable water vapor

PACS Visible and Near Infrared (VNIR) Parameters

- Wavelengths: 470, 550, 670, 865, and 910 nm
- Resolution from ER-2 altitude: 37 m
- Cross track swath: 37 km
- 1000 pixels cross track
- 22 along track angles at 470, 550, and 865 nm
- 66 cloudbow angles at 670 nm

PACS Principal Investigator

J. Vanderlei Martins
University of Maryland Baltimore County/JCET
NASA Goddard Space Flight Center
martins@umbc.edu

PACS Team Members

Roberto Fenandez-Borda
University of Maryland Baltimore County/JCET
NASA Goddard Space Flight Center

Ralph Kahn
NASA Goddard Space Flight Center

Lorraine Remer
NASA Goddard Space Flight Center

Lerroy Sparr
NASA Goddard Space Flight Center

Science Questions for Future Campaigns

- What are the true scattering properties of generic aerosols (spherical and non-spherical) and cloud ice particles?

Pandora and Cleo

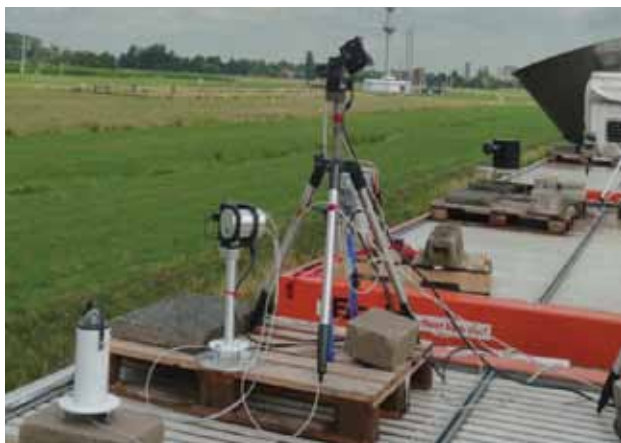

One Cleo spectrometer (left) and two Pandora spectrometers (center and right) deployed on a field trip in Cabauw, Holland.

Key Facts

- Heritage: Pandora and Cleo are new instruments developed in Code 613.3 to improve greatly the capabilities and reduce the cost of more existing expensive instruments (Brewer and the UV-MFRSR filter shadowband). The largest source of improvement in these instruments compared to their predecessors is the ability to measure all of the wavelengths simultaneously and to oversample the wavelengths at three times the resolution of the spectrometers. This eliminates the variability (noise) introduced into the measurements when the atmosphere changes in the short time between measurements at different wavelengths with the Brewer and UV-MFRSR. The result is extreme precision.
- NO₂ is measured at a precision of 0.01 DU relative to a typical value of 0.5 DU. With laboratory and field calibration, the absolute accuracy of Pandora for NO₂ measurements is 0.1 DU.
- Multiple copies of the Pandora and Cleo are being deployed at various sites in support of satellite and aircraft measurements.

Descriptions

Pandora can measure the UV and visible spectrum and is radiometrically stable and has picometer wavelength stability. This new spectrometer system incorporates a dual filter wheel for increased dynamic range for sun and sky measurements, polarization filters, and UV band-pass filters. The result is an instrument that can measure a variety of trace gases (O₃, SO₂, BrO, HCHO, NO₂, H₂O), as well as aerosol amounts and optical properties. The instrument can also determine altitude

profiles of the various species. Pandora is lightweight (less than 10 kg) and is highly portable for easy field operation.

Cleo operates by alternately blocking the sun with the black band (shadowband) and measuring the global solar irradiance (direct plus diffuse). The ratio of diffuse to global is used to determine aerosol properties such as optical depth and single scattering albedo (absorption). The spectral attributes of the absorption coefficient can be used to distinguish between different types of absorbing aerosols. By moving the band in very small steps, Cleo also measures the solar aureole to estimate the particle size distribution.



The optical heads (shown) lead to small spectrometers the size of a paperback novel connected with a fiber optic cable.

Data Products

Pandora

- O₃, SO₂, BrO, HCHO, NO₂, H₂O
- Aerosol Amounts
- Optical Properties

Cleo

- Direct plus diffuse solar irradiance
- Aerosol properties (optical depth and single scattering albedo)
- Particle size distribution (derived from solar aureole)

Parameters

Pandora

- UV and visible spectrum from 290 to 525 nm
- Resolution: 0.5 nm

Cleo

- Wavelength region: 300–825 nm
- Resolution: 1 nm

Pandora Team Members/Co-Investigators

Nader Abuhassan
University of Maryland, Baltimore County

Alexander Cede
University of Maryland, Baltimore County

Jay Herman
University of Maryland, Baltimore County
Joint Center for Earth Systems Technology

Science Goals for Future Campaigns

Pandora and Cleo are used in support of satellite validation programs (e.g., AURA/OMI) and in support of aircraft campaigns. A proposal has been submitted to fly aircraft in the US, perform regional modeling, and set up 12 Pandora and some Cleo instruments underneath the flight path for ground truth measurements. In addition, Cleo is being set up for

use on coastal boats in a joint effort with Dr. John Moisan from NASA's Wallops Flight Facility. A spring campaign is planned for Fairbanks, Alaska to measure BrO, total ozone, and ozone profiles. Pandora and Cleo instruments will be located at several permanent sites around the United States for long-term measurements. One such instrument has already been delivered to NASA's Langley Research Center.



Side view of Cleo showing the shadowband.

SDS

Solar Disk Sextant



SDS preparing for launch from Fort Sumner, New Mexico.

Key SDS Facts

- Heritage: Designed at GSFC for climate/solar physics studies by means of ultra precise measurements of the solar diameter and shape.
- The SDS uses a custom fused silica wedge to insure a long term, stable calibration reference.
- The SDS is a balloon-borne payload that is launched by CSBF at its facility in Fort Sumner, New Mexico.

Description

The Solar Disk Sextant (SDS) is a balloon-borne experiment whose objective is to measure the diameter of the Sun with a precision of several milli-arc-seconds, maintained over a time frame of decades. It has flown six times starting in 1992, and the latest flight was in October 2009. It is scheduled to fly again in fall 2011, with the primary objective of inter-calibration with the SODISM experiment onboard the CNES PICARD satellite, which was launched on June 15,

2010. The resultant diameter measurements are to be used along with simultaneous solar luminosity measurements to determine the relationship between radius and luminosity changes in the Sun. The team can then use historical solar radius change data (obtained from solar eclipse timings) to determine the amplitude of solar luminosity changes in the past. This is to help in validating climate models. In addition, as a byproduct of this research, the team plans to obtain a value for the solar oblateness, which is of great interest to those working in relativity and fluid dynamics and several areas of solar physics.

SDS Data Products

- Solar diameter
- Solar shape

SDS Instrument Parameters

- Main telescope is a ruggedized 7-in Questar.
- Reference wedge is 1/50 wave, optically bonded fused silica, detector package = 7 linear CCDs.

Principal Investigator

Sabatino Sofia
Yale University
Sabatino.sofia@yale.edu

Goddard Space Flight Center Principal Investigator

William Heaps
NASA Goddard Space Flight Center
William.S.Heaps@nasa.gov

SDS Team Members

Terry Girard
Yale University

U. J. Sofia
American University

Laurence Twigg
Science Systems and Applications, Inc.

Co-Investigators

Gerard Thuillier
CNES/LATMOS

Science Question for Future Campaigns

- How do the solar diameter and shape change with time?
- How do the SDS and SODISM (an instrument currently flying on the ESA PICARD satellite) solar diameter measurements compare?
- How does the solar diameter change effect climate?

References

Sofia, S., Heaps, W., and Twigg, L.W. 1994: *Ap. J*, **427**, 1048.

Egidi, A., Caccin, B., Sofia, S., Heaps, W., Hoge, W. and Twigg, L. 2006: *Solar Physics*, **247**, 225.

Djafer, D., Thuillier, G., Sofia, S. and Egidi, A. 2008: *Solar Physics*, **247**, 225.

SMART

Surface-Sensing Measurements for Atmospheric Radiative Transfer



The SMART trailer is the Laboratory's first mobile lab, which hosts an array of remote sensing instruments.

Key SMART Facts

- Nominal field configuration: Ground-based station with many global, diffuse, and direct broadband radiometers (Fig. a); sun/sky/surface photometers and a shadow-band radiometer (Fig. b); a spectroradiometer (Fig. c); a whole sky imager, a micro-pulse lidar, and an interferometer (Figs. d, e, and f); a scanning microwave radiometer with a physical and optical rain gauge and meteorological sensors (Figs. g, h, i, and j); and several data loggers and a local computer network operating inside the trailer (Figs. k and l).
- SMART URL: <http://smart-commit.gsfc.nasa.gov/>

Description:

The instrument list grew from a micro-pulse lidar, a sun photometer and five broadband radiometers in 1998, to more than two-dozen devices covering a wide spectral range—from ultraviolet, visible, near-infrared, shortwave-infrared, and longwave-infrared, to microwave. As the suite evolves, all the instruments are integrated into a 20-ft weather-sealed trailer with a thermostatic temperature control to facilitate the shipping to, and operation in, the field.

SMART has been deployed in many international and domestic field experiments. Many unique data sets have been generated for ground-based remote sensing studies in atmospheric sciences.

A companion *in situ* measurement package is built to form the SMART-COMMIT mobile laboratories.

The SMART-COMMIT mission is designed to pursue the following goals:

- EOS validation

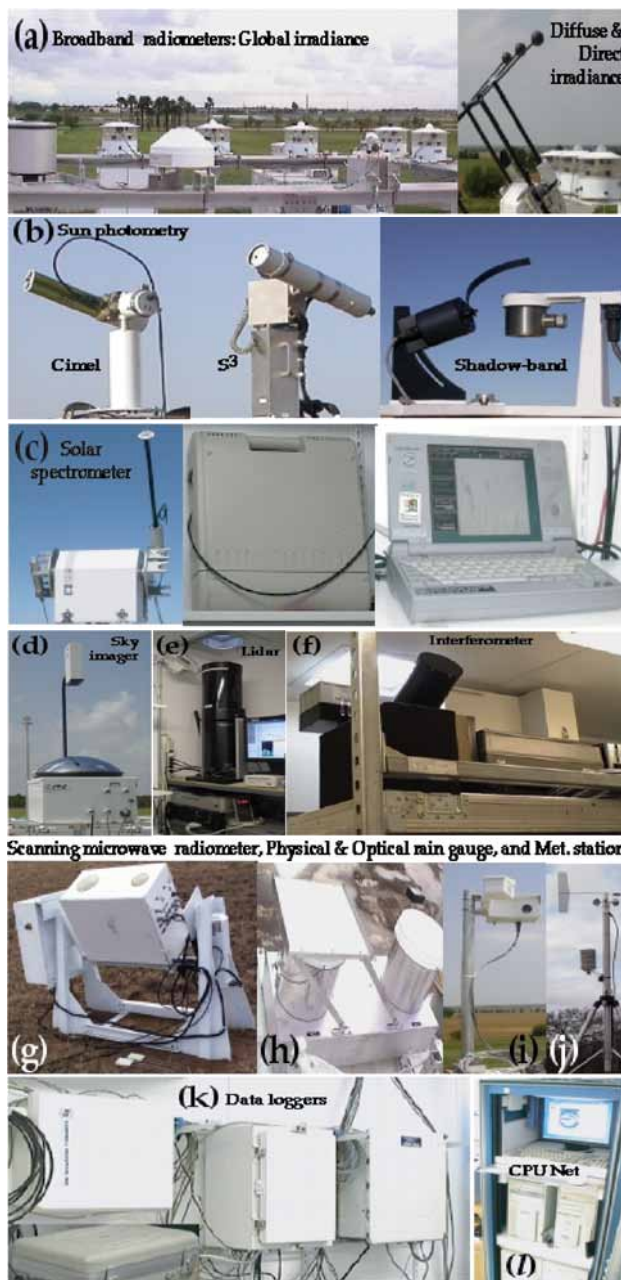

- Innovative investigations
- Long-term atmospheric monitoring

SMART Data Products

- Global, diffuse, and direct solar irradiance with various bands of energy partitioning
- Global sky longwave-infrared irradiance
- Transmitted and sky-solar spectral radiance and various narrow-band radiance at atmospheric window regions
- Emitted downwelling infrared radiance
- Microwave downwelling sky radiance
- Normalized backscatter intensity
- Total sky imagery
- Meteorological conditions near the ground

SMART Parameters

- Broadband wavelengths: 0.3-3, 0.4-3, 0.7-3, and 4-50 μm (global, diffuse, and direct component)

- Narrowband wavelengths: 302, 308, 315, 336, and 377 nm (global); 414, 498, 614, 672, 866, and 939 nm (global and diffuse); 340, 380, 440, 500, 670, 870, and 870 nm horizontally polarized, 870 nm vertically polarized, 940, 1020, 1240, 1440, and 2130 nm (direct)
- Laser frequency: 532 nm
- Shortwave spectra: 0.35-2.5 μm
- Longwave spectra: 3-20 μm
- Microwave: 23, 36, and 90 GHz
- Sky image: red, green, and blue (RGB)
- Meteorological parameters: pressure, temperature, relative humidity, wind direction, and speed (u , v , respectively)

SMART Team Members

Qiang Ji
University of Maryland, College Park

Si-Chee Tsay
NASA's Goddard Space Flight Center

In Situ Instrument Systems

COMMIT

Chemical, Optical, and Microphysical Measurements of In-situ Troposphere



Key COMMIT Facts

Heritage: Extending the success of the SMART mobile facility, COMMIT was built in 2006 as the companion in situ observatory for studying some basic chemical, optical and microphysical properties of atmospheric aerosols and trace gases. Like SMART, all COMMIT instruments are integrated in a 20-foot weather-sealed trailer with thermostatic temperature control. These two mobile laboratories can be deployed and operated together or individually. COMMIT has now been an integral part of multiple field campaigns, including the ongoing Asian monsoon years 2008-12, NAMMA (2006), and BASE-ASIA (2006).

Normal Field Configuration: COMMIT is equipped with an inlet stack to ingest sample air from 10 meters above the ground and to split it into several groups of instruments: an ambient particle monitor for aerosol mass concentration and chemical composition (Fig. a), three particle sizers for aerosol size distribution (Fig. b), a three-wavelength nephelometer for particle scattering in the visible (Fig. c), three single-wavelength nephelometers for particle light scattering at different relative humidities (Fig. d), a three- and a seven-wavelength aethalometer for particle absorption in the visible (Fig. e), and five trace gas analyzers for nitrogen monoxide/

dioxide, sulfur dioxide, carbon monoxide/dioxide, and ozone concentrations (Fig. f). In addition, the surface skin temperature and meteorological parameters near the surface and up to 2 km by tethered balloons (5 and 15 m³) are measured (Figs. g, h, and i).

COMMIT URL: <http://smart-commit.gsfc.nasa.gov/>



Science Questions

- How are the chemical and microphysical properties of aerosol particles linked to their optical properties?
- How are the aerosol properties near the surface related to those in the boundary layer and aloft?
- Can we better quantify the aerosol indirect effect on the climate?

Principal Investigators

Judith C. Chow
Desert Research Institute
judy.chow@dri.edu

J. Vanderlei Martins
University of Maryland, Baltimore County
martins@umbc.edu

Science Team Members

Shaun W. Bell
Science Systems and Applications, Inc.

Qiang “Jack” Ji,
University of Maryland, College Park

Can Li
University of Maryland, College Park

Si-Chee Tsay
NASA's Goddard Space Flight Center

COMMIT Data Products

- Aerosol particle mass concentration
- Aerosol chemical composition

- Aerosol particle size distribution
- Aerosol light scattering coefficient
- Aerosol light absorption coefficient
- Trace gas concentration
- Surface skin temperature
- Meteorological conditions, surface to 2 km

COMMIT Parameters

- Aerosol particle mass concentration with size cut at PM-10 (μm), PM-2.5, and PM-1
- Aerosol size distribution: 5 nm \sim 20 μm
- Aerosol light scattering coefficient at 450, 550, and 700 nm
- Aerosol light scattering coefficient at 530 nm, for dried, ambient, and humidified air samples
- Aerosol light absorption coefficient at (470, 522, and 660 nm) and (370, 430, 470, 520, 565, 700, and 950 nm)
- Gas concentration: NO/NO_x, SO₂, CO, CO₂, and O₃
- Meteorological parameters: pressure, temperature, relative humidity, wind direction and speed (u , v), surface to 2 km

Microwave Instrument Systems

ACHIEVE

Aerosol-Cloud-Humidity Interactions Exploring and Validating Enterprise

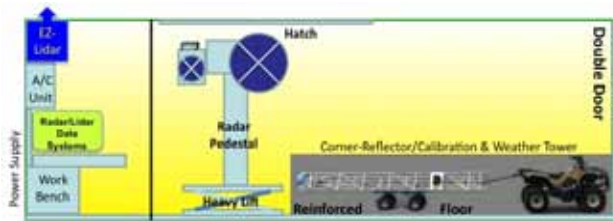

Description:

Accurate retrievals of aerosol and cloud properties from space-borne sensors have been achieved with certain degrees of confidence. One of the most difficult tasks remaining to be resolved is the interaction between aerosols and clouds when they co-exist. Solid ground-based observations of the aerosol-cloud-water cycle interactions are critical for providing independent assessments. ACHIEVE, extending the success of SMART-COMMIT mobile facility, is being built to provide urgently needed test-bed data with high temporal and spectral resolutions. A synergy of ground-based and airborne remote sensing and in-situ measurements will serve well in supporting satellite retrievals and validation, as well as diagnostic/prognostic modeling studies.

Like SMART-COMMIT, all ACHIEVE instruments will be integrated in a 20-foot weather-sealed trailer with thermostatic temperature control. These three mobile laboratories can be deployed and operated together or individually. ACHIEVE will be equipped mainly with active remote sensing instruments: a 95 GHz and 24 GHz radar mounted on a heavy-duty pedestal (Fig. a), a near-IR ceilometer (Fig. b), and a UV-wavelength lidar for aerosol extinction (Fig. c). In addition, two passive scanning microwave radiometers operating in SMART complement ACHIEVE.

ACHIEVE Data Products

- Cloud mask and cloud type
- Cloud base/top heights
- Cloud liquid/ice water content
- Precipitation occurrence
- Cloud optical thickness and effective radius profiles
- Aerosol precursors below clouds

ACHIEVE Parameters

- Cloud radars: 24 and 95 GHz
- Radiometers: 20, 36, and 89 GHz
- Ceilometer: 910 nm
- Lidar: 355 nm

Future Plans

- First field deployment to the 7 South East Asian Studies (7-SEAS) in March 2012, in concert with validating Glory, NPP, and other programs.

Science Team Members

Shaun W. Bell
Science Systems and Applications, Inc.
Shaun.W.Bell@nasa.gov

Qiang "Jack" Ji
University of Maryland, College Park
qiang.ji-1@nasa.gov

Si-Chee Tsay
NASA's Goddard Space Flight Center
si-chee.tsay@nasa.gov

Collaboration Members

N. Christina Hsu
NASA's Goddard Space Flight Center

William K. Lau
NASA's Goddard Space Flight Center

Wei-Kuo Tao
NASA's Goddard Space Flight Center

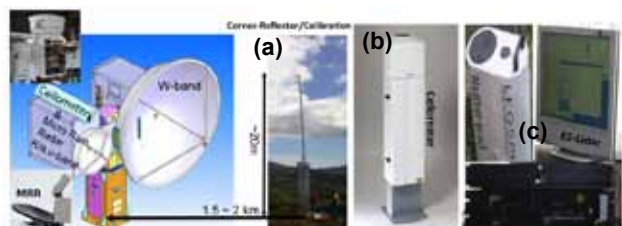

CoSMIR

Conical Scanning Millimeter-wave Imaging Radiometer

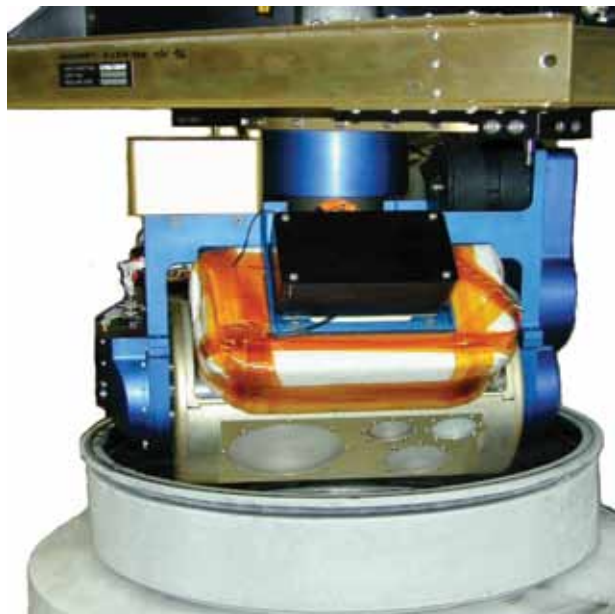

Figure showing CoSMIR in laboratory calibration with liquid nitrogen. The four antennae apertures correspond to the four visible receivers.

Key CoSMIR Facts

- **Heritage:** An improved version of GSFC airborne MIR (Millimeter-wave Imaging Radiometer), capable of acquiring radiometric data over the frequency range of 50–183 GHz in conical or across-track scan modes or both.
- Onboard the NASA ER-2 aircraft, performed calibration/validation of the high-frequency channels of the Special Sensor Microwave Imager/Sounder (SSMIS), a new generation orbiting microwave imager/sounder for the DMSP (Defense Meteorological Satellite Project) F-16 satellite during 2004–2005.
- Modified to conform to high-frequency channels of the GMI (Global Precipitation Measurement mission Microwave Imager) and to acquire data in field campaigns for algorithm development of precipitation retrievals.
- **Nominal Field Configuration:** CoSMIR is designed to operate onboard the NASA ER-2 aircraft, but it can be installed and flown in other aircraft with an appropriate nadir port (e.g., DC-8 aircraft). As GMI (GPM Microwave Imager) airborne simulator, a new scan mode to acquire both conical and across-track scan data simultaneously in

a given flight is implemented to satisfy the requirements of the PMM algorithm development team.

CoSMIR Parameters

- **Frequencies:** 9 channels at 50.3, 52.6, 89 (H & V), 165.5 (H & V), 183.3±1, 183.3±3, and 183.3±7 GHz.
- **Scan Modes:** Programmable for conical scan at angles between 0–53.6°, across scan, or a combination of both.
- **In-flight Calibration:** two external targets at ~328 K and at ambient temperature (~ 250 K at ER-2 aircraft cruising altitudes).
- **Scan head:** a cylinder 21.5 cm in diameter and 28.0 cm long.
- **FOV:** ~4° beam width (gives a nadir footprint at the surface of about 1.4 km at ER-2 cruising altitude of 20 km).

Description

CoSMIR is an airborne, nine-channel, total power radiometer that was originally developed for the calibration/validation of the SSMIS. When first completed in 2003, the system had four receivers near 50, 91, 150 and 183 GHz that measured horizontally polarized radiation at the frequencies of 50.3, 52.8, 53.6, 150, 183.3±1, 183.3±3, and 183.3±6.6 GHz, and dual polarized radiation at 91.665 GHz from onboard the high-flying NASA ER-2 aircraft. All receivers and radiometer electronics are housed in a small cylindrical scan head (21.5 cm in diameter and 28 cm in length) that is rotated by a two-axis gimballed mechanism capable of generating a wide variety of scan profiles. Two calibration targets, one maintained at ambient (cold) temperature and another heated to a hot temperature of approximately 328 K, are closely coupled to the scan head and rotate with it about the azimuth axis. Radiometric signals from each channel are sampled at 0.01 sec intervals. These signals and housekeeping data are fed to the main computer in an external electronics box.

CoSMIR has been flown only for calibration/validation of the SSMIS during years 2004–2005 off the coastal areas of California. Currently, it is being modified to play the role as an airborne high-frequency simulator for the GMI, which requires changes in both frequency and polarization for some channels. After modification, the nine channels will be at the frequencies of 50.3, 52.6, 89 (H and V), 165.5 (H & V), 183.3±1, 183.3±3, and 183.3±7 GHz. All channels

besides 89 and 165.5 GHz will be horizontally polarized. The modified CoSMIR will fly in a GPM-related field campaign in Oklahoma during April–May 2011.

CoSMIR Data Products

- Well-calibrated radiometric data between 50–183 GHz with accuracy on the order of ± 1 K.
- Through various retrieval algorithms, the acquired data can be used to estimate snowfall rates, water vapor profiles (with known temperature profiles), light precipitation, and shallow snow cover on the ground.

Principal Investigator

Gail Scofronick-Jackson
NASA's Goddard Space Flight Center
Gail.S.Jackson@nasa.gov

Co-Investigators/ Team Members

Bryan Monosmith
NASA's Goddard Space Flight Center

James Wang
Science Systems and Applications, Inc.

References

Wang, J.R., P.E. Racette, J.E. Piepmeier, B. Monosmith, and W. Manning. 2007: Airborne CoSMIR observations between 50 and 183 GHz over snow-covered Sierra mountains," *IEEE Trans. Geosci. Remote Sens.*, **45**, 55–61.

Wang, J.R., P.E. Racette, and J.E. Piepmeier. 2008: A comparison of near concurrent measurements from the SSMIS and CoSMIR for some selected channels over the frequency range of 50–183 GHz, *IEEE Trans. Geosci. Remote Sens.*, **46**, 923–933.

CoSSIR

Compact Scanning Submillimeter-wave Imaging Radiometer

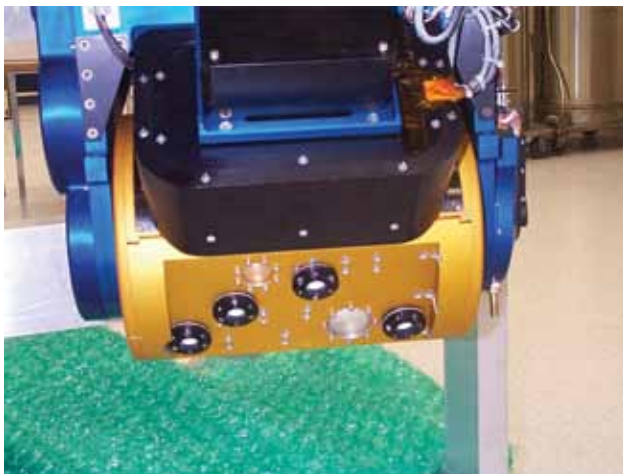

Figure showing CoSSIR in system functional check. The five antenna apertures corresponding to the five receivers are clearly displayed.

Key CoSSIR Facts

- **Heritage:** An instrument implemented for the measurements of ice clouds. It has five receivers covering the frequency range of 183-874 GHz, that are housed in a compact cylinder 21.5 cm in diameter and 28.0 cm long. All receivers at frequencies > 183 GHz were developed under the Small Business Innovation Research (GSFC SBIR) program.
- Flown on the NASA ER-2 aircraft during the Cirrus Regional Study of Tropical Anvils and Cirrus Layers–Florida Area Cirrus Experiment (CRYSTAL–FACE) in 2002 and the Tropical Composition, Cloud and Climate Coupling (TC4) experiment in 2007.
- Recently modified to serve as an airborne simulator for the Submillimeter-Wave and Infrared Ice Cloud Experiment (SIRICE), a potential NASA Earth science satellite mission, and to acquire data in field campaigns for algorithm development of ice-cloud parameter retrievals.
- **Nominal Field Configuration:** CoSSIR is designed to operate onboard the NASA ER-2 aircraft, but it has also been installed in WB-57 aircraft. In both CRYSTAL–FACE and TC4, the system acquired data mainly in conical scan mode. Recently, a new scan mode to acquire both conical and across-track scan data simultaneously during a given flight was successfully implemented and tested to satisfy the future science requirements.

Description

CoSSIR is an airborne, nine-channel total power imaging radiometer that was mainly developed for the measurements of ice clouds. However, it can be used for estimation of water vapor profiles and snowfall rates. When first completed and flown in the CRYSTAL–FACE field campaign during July 2002, the system had 15 channels at different frequencies from those listed above. All the receivers and radiometer electronics are housed in a small cylindrical scan head (21.5 cm in diameter and 28 cm in length) that is rotated by a two-axis gimballed mechanism capable of generating a wide variety of scan profiles. Two calibration targets, one maintained at ambient (cold) temperature and another heated to a hot temperature of about 328 K, are closely coupled to the scan head and rotate with it about the azimuth axis. Radiometric signals from each channel are sampled at 0.01 sec intervals. These signals and housekeeping data are fed to the main computer in an external electronics box.

CoSSIR Data Products

- Well-calibrated radiometric data between 183-874 GHz with accuracy on the order of ± 1 K.
- Through various retrieval algorithms, the acquired data can be used to estimate ice cloud parameters (ice water path and mean ice particle size), snowfall rates, and water vapor profiles (with known temperature profiles).

CoSSIR Parameters

- **Frequencies:** 12 channels at 183.3 \pm 1, 183.3 \pm 3, 183.3 \pm 7, 325 \pm 1.5, 325 \pm 3.5, 325 \pm 9.5, 448 \pm 1.4, 448 \pm 3, 448 \pm 7.2, 642 (H and V), and 874 GHz.
- **Scan Modes:** Programmable for conical scan at angles between 0–53.6°, across scan, or a combination of both.
- **In-flight Calibration:** two external targets at \sim 328° K and at ambient temperature (\sim 250 K at ER-2 aircraft cruising altitudes)
- **Scan head:** a cylinder 21.5 cm in diameter and 28.0 cm long
- **FOV:** \sim 4° beam width (gives a nadir footprint at the surface of about 1.4 km at ER-2 cruising altitude of 20 km)

Principal Investigator

Frank Evans
University of Colorado, Boulder
evans@nit.colorado.edu

Co-Principal Investigator

David Starr
NASA's Goddard Space Flight Center
David.Starr@nasa.gov

Team Members

Bryan Monosmith
NASA's Goddard Space Flight Center

References

Evans, K.F., J.R. Wang, P.E. Racette, G. Heymsfield, and L. Li. 2005: Ice cloud retrievals and analysis with data from the Conical Scanning Submillimeter Imaging Radiometer and the Cloud Radar System during CRYSTAL-FACE, *J. Appl. Meteor.*, **44**, 839–859.

Wang, J.R., L.A. Chang, B. Monosmith, and Z. Zhang. 2008: Water vapor profiling from CoSSIR radiometric measurements, *IEEE Trans. Geosci. Remote Sensing*, **46**, 137–145.

CRS

Cloud Radar System



CRS instrument and antenna located in the tail section of an ER-2 SuperPod. The antenna points at nadir.

Key CRS Facts

- Heritage: Second generation ER-2 instrument based on the ER-2 Doppler Radar (EDOP). Several other ground-based and lower-altitude airborne W-band radars are present in the community.
- A Doppler cloud radar system at W-band (94 GHz) developed for the ER-2 aircraft. Vertical profiles of radar reflectivity and hydrometeor motions are produced.
- The first deployment of CRS was in CRYSTAL-FACE during Summer 2002. Participated in TCSP, TC4, and CLASIC.
- Nominal aircraft configuration: The CRS system is configured for operation in the unpressurized tailcone of an ER-2 wing SuperPod. The single nadir antenna radiates through a 20 in × 20 in opening in the SuperPod.
- CRS URL: <http://bar.gsfc.nasa.gov>

Description

Cloud radars at millimeter wavelengths have demonstrated high sensitivity to clouds. These radars, at frequencies above 35 GHz, have been used in various ground-based and airborne studies that focus on the effect of clouds on the Earth's radiation budget. The CloudSat mission has 94 GHz cloud radar as its primary instrument. Cloud radars have strong synergism with profiling backscatter lidars which have higher sensitivity to cirrus and other clouds, but whose signal becomes considerably more attenuated in thicker, more opaque clouds. The ER-2 platform provides the best satellite-like view of the tropospheric clouds and along with CRS, has

a powerful suite of cloud remote sensing instruments. CRS is a W-band (94 GHz) cloud radar that is a fully coherent Doppler system with a fixed nadir pointing beam, which maps out Doppler winds and reflectivities in the vertical plane. CRS, combined with the existing CPL backscatter lidar system on the ER-2, provided a testbed for algorithms and a validation platform for the upcoming CloudSat and Calipso missions, as well as for the future ACE Decadal Survey Mission.

CRS Data Products

- Vertical profiles: radar reflectivity, hydrometeor and air vertical motions, ice and liquid water content, cloud layer locations
- Measurement interval: 37.5 m vertical, 100 m along track
- –Measurement accuracy: reflectivity of 1.0 dBZ; winds at 0.5 m s^{-1}

CRS Parameters

- Transmitter peak power: 1.7 kW
- Frequency: 94.155 GHz
- Pulse repetition frequency: 4000/5000 Hz (staggered)
- Pulse width: 0.5 μs .
- Receiver IF: 60 MHz
- Dynamic range: 80 dB
- Minimum detection signal: -29 dBZ (at 10 km range)

Principal Investigator

Gerald M. Heymsfield
 NASA's Goddard Space Flight Center
Gerald.M.Heymsfield@nasa.gov

CRS Team Members

Lihua Li
 NASA's Goddard Space Flight Center

Lin Tian
 Goddard Earth Sciences and Technology Center

Edward Zenker
 EZ Software, Inc.

Science Questions for Future Campaigns

- What are the particle sizes and ice contents in thunderstorm-generated cirrus?
- What is relation between convective intensity and the extent and depth of cirrus anvils generated by the convection?
- What are the growth mechanisms in cirrus clouds?
- What is the best approach for obtaining information on the cirrus properties using radar, lidar, and microwave and visible near-infrared radiometers?

References

- Heymsfield, G.M., L. Li, L. Tian, M. McGill, and Z. Wang. 2003: Thunderstorm generated cirrus observed from X and W-band airborne radar during CRYSTAL-FACE. Preprints, 31st AMS Conf. Radar Meteor., Seattle, Washington, 2003.
- Li, L., G.M. Heymsfield, P.E. Racette, and L. Tian, 2003: Calibration of a 94 GHZ airborne cloud radar using measurements from the ocean surface. Preprints, 31st AMS Conf. Radar Meteor., Seattle, Washington, 2003.
- Li, L., G.M. Heymsfield, P.E. Racette, and E. Zenker. 2003: A 94 GHz cloud radar system on a NASA ER-2 aircraft. *J. Atmos. Ocean. Tech.*, **21**, 1378–1388.
- Li, L., G.M. Heymsfield, L. Tian, and P.E. Racette. 2005: Measurements of ocean surface backscattering using an airborne 94-GHz cloud radar – Implication for calibration of airborne and spaceborne W-band radars, *J. Atmos. Oceanic Tech.*, **22**, 1033–1045.
- Liao, L., R. Meneghini, L. Tian, and G. M. Heymsfield. 2009: Measurements and simulations of nadir-viewing radar returns from the bright band at X- and W-Bands, *J. Appl. Meteor. and Clim.*, **48**, 2215-2226.
- McGill, M.J., L. Li, W.D. Hart, G. M. Heymsfield, D.L. Hlavka, P.E. Racette, L. Tian, M. A. Vaughan, and D.M. Winker. 2004: Combined lidar-radar remote sensing: initial results from CRYSTAL-FACE, *J. Geophys. Res.*, **109**, D2703.
- Tian, L., G. M. Heymsfield and L. Li, 2003: Stratiform precipitation observed by airborne radar at 94 and 10 GHZ. Preprints, 31st AMS Conf. Radar Meteor., Seattle, Washington, 2003.
- Tian, L., G. M. Heymsfield, L. Li, A. J. Heymsfield, A. Bansemmer, C.H. Twohy, and R.C. Srivastava. 2009: A study of cirrus ice particle size distribution using TC4 observations, *J. Atmos. Sci.*, **67**, 195–216.

EDOP

ER-2 Doppler Radar



Aft view of EDOP nose showing transmitter and data system.

Key EDOP Facts

- Heritage: Goddard/Communications Research Lab (Japan) dual-frequency airborne radar (Tropical Rainfall Measuring Mission [TRMM] algorithm development), lower altitude scanning Doppler radars.
- A Doppler weather radar system at X-band (9.6 GHz) was developed for the ER-2 aircraft. Vertical profiles of radar reflectivity and hydrometeor motions are produced.
- Participated in CAMEX 1, 2, 3, and 4; the Houston Precipitation Experiment (HOPEX); Texas and Florida Underflight Experiment (TEFLUN) A and B, TRMM LBA, CRYSTAL-FACE, TCSP, and TC4.
- Nominal aircraft configuration: The EDOP system is configured for operation in a refurbished military radar nose for the ER-2. Two fixed beams are used: one is pointing at nadir and the other is 33° forward of nadir.
- EDOP URL: <http://bar.gsfc.nasa.gov>

Description

Airborne weather radar systems have played an important role in studying mesoscale convective systems (MCSs) and other mesoscale and cloud-scale phenomenon. These radars have provided important information on kinematic and dynamical aspects of isolated thunderstorms, MCSs, and hurricanes.

Mesoscale phenomena often have long lifetimes (12–24 h), have large spatial extent (several hundred kilometers), and advect considerable distances over their lifetime. As a result, ground-based radars may not be suitably located for high-resolution measurements of MCSs and hurricanes because of either large radar slant ranges, or from the radars, or that the MCSs are located over open ocean. In addition, most airborne weather radars are side-looking and do not provide coverage of the top portions of weather systems.

The system operates at X-band (9.6 GHz) and is a fully developed, coherent Doppler weather radar with fixed nadir and forward pointing beams that map out Doppler winds and reflectivities in the vertical plane along the aircraft motion vector. Doppler winds from the two beams can be used to derive vertical and along-track air motions. In addition, the forward beam provides linear depolarization measurements, which are useful in discriminating microphysical characteristics of the precipitation.

EDOP Data Products

- Vertical profiles: Radar reflectivity, hydrometeor vertical motions, u , w wind components, rain rate, hail, and melting layer discrimination.
- Measurement interval: 37.5 m vertical, 100 m along-track
- Measurement accuracy: Reflectivity at 0.5 dBZ; winds 0.5 m s⁻¹

EDOP Parameters

- Transmitter peak power: 20 kW
- Split between 2 antennae
- Radio Frequency: 9.6 GHz
- Pulse repetition frequency: 4400 Hz
- Pulse width: 0.5 μs
- Receiver IF: 60 MHz
- Dynamic range: >90 dB

Principal Investigator

Gerald M. Heymsfield
 NASA's Goddard Space Flight Center
Gerald.M.Heymsfield@nasa.gov

EDOP Team Members

Lihua Li
NASA's Goddard Space Flight Center

Lin Tian
Goddard Earth Sciences and Technology Center

Edward Zenker
EZ Software, Inc.

Science Questions for Future Campaigns

- What is the role of convective bursts on hurricane intensification and track?
- What is the relation between convective intensity and the extent and depth of cirrus anvils generated by the convection?
- What is the distribution of rainfall in landfalling hurricanes?
- How well are hydrometeor particle size distributions represented in TRMM algorithms?
- How does overshooting convection interact with the lower stratosphere?

References

Geerts, B., G.M. Heymsfield, L. Tian, J.B. Halverson, A. Guillory, and M.I. Mejia, 2000: Hurricane Georges' landfall

in the Dominican Republic: Detailed airborne doppler radar imagery. *Bull. Amer. Meteor. Soc.*, **81**, 999–1018.

Heymsfield, G. M., L. Tian, A.J. Heymsfield, L. Li, and S. Guimond, 2010: Characteristics of deep tropical and subtropical convection from nadir-viewing high-altitude airborne Doppler radar. *J. Atmos. Sci.*, **67**, 301–324.

Heymsfield, G.M., S. Bidwell, I.J. Caylor, S. Ameen, S. Nicholson, W. Boncyk, L. Miller, D. Vandemark, P.E. Racette, and L.R. Dod, 1996: The EDOP radar system on the high altitude NASA ER-2 aircraft. *J. Atmos. Ocean. Tech.*, **13**, 795–809.

Heymsfield, G.M., J. B. Halverson, J. Simpson, L. Tian, and P. Bui, 2001: ER-2 Doppler Radar (EDOP) investigations of the eyewall of Hurricane Bonnie during CAMEX-3. *J. Atmos. Meteor.*, **40**, 1310–1330.

Tian, L., G. Heymsfield, and R.C. Srivastava, 2001: Measurement of attenuation with airborne and ground-based radar in convective storms over land and its microphysical implications. *J. Atmos. Ocean. Tech.*, **41**, 716–733.

HIWRAP

High-altitude Imaging Wind and Rain Airborne Profiler



Key HIWRAP Facts

- Heritage: HIWRAP is a completely new instrument developed under the NASA IIP and it was designed specifically for the Global Hawk.
- It is a conical scanning Doppler radar with two frequencies (Ku- and Ka-band) and two incidence angles (30 and 40 degrees).
- The first deployment of HIWRAP was for the Genesis and Rapid Intensification Processes (GRIP) campaign in 2010.
- Nominal Aircraft Configuration: HIWRAP is configured for operation in the zone 25 unpressurized radome area in the Global Hawk. The single dual-frequency, dual-beam aperture views through the Global Hawk deep radome. HIWRAP will be reconfigured for a nadir-pointing mode on the NASA ER-2.
- HIWRAP URL: <http://bar.gsfc.nasa.gov/>

Description

Wind measurements are crucial for understanding and forecasting tropical storms since they are closely tied to the overall dynamics of the storm. The High-Altitude Imaging Wind and Rain Airborne Profiler (HIWRAP) is a dual-frequency (Ka- and Ku-band), dual-beam (300 and 400 incidence angle), conical scan, solid-state transmitter-based system, designed for operation on the high-altitude (20 km) Global Hawk UAV. With the inclusion of Ka-band, HIWRAP will be able to image the winds through volume

backscattering from clouds and precipitation, enabling it to measure the tropospheric winds above heavy rain at high levels. It will also measure ocean surface winds through scatterometry, similar to QuikScat. These measurements from higher altitudes above storms, will be useful for providing higher spatial and temporal resolution than obtained by current satellites and lower-altitude instrumented aircraft. HIWRAP is configured for flying autonomously on the NASA Global Hawk. It completed its first deployment during the GRIP field campaign in 2010.

HIWRAP Data Products

- 3D structure below aircraft: radar reflectivity, horizontal winds, ice and liquid water content.
- Ocean surface winds: Over conical scan swath
- Measurement interval: 150 m in range initially, 37.5 m future, 600 m along-track
- Measurement accuracy:
- Reflectivity: 1.0 dBZ; winds 0.5 m/s

Parameters:

Ku-band

- Radio frequency: inner beam 13.91 GHz; outer beam 13.47 GHz
- Peak transmit power: 25 W
- 3 dB beamwidth: 3.0 degrees
- Polarization: V (outer beam), H (inner beam)
- Dynamic range: >65 dB
- Min. detect. reflectivity: 0 dBZ_e (60 m res 10 km range)
- Doppler velocity: 0-150 m/s (uncertainty <2 m/s for SNR>10)
- Scanning: conical scan 10–30 rpm

Ka-band

- Radio frequency: inner beam 35.56 GHz; outer beam 33.72 GHz
- Peak transmit power: 8 W
- 3 dB beamwidth: 1.2 degrees

- Polarization: V (outer beam), H (inner beam)
- Dynamic range: >65 dB
- Min. detect. reflectivity: -5 dBZe (60 m res 10 km range)
- Doppler velocity: 0-150 m/s (uncertainty <2 m/s for SNR>10)
- Scanning: conical scan 10–30 rpm

Principal Investigator

Gerald M. Heymsfield
 NASA's Goddard Space Flight Center
Gerald.Heymsfield@nasa.gov

HIWRAP Team Members
 Lihua Li
 NASA's Goddard Space Flight Center

Matthew Mclinden
 NASA's Goddard Space Flight Center

Martin Perrine
 NASA's Goddard Space Flight Center

Lin Tian
 University of Maryland, Baltimore County
 Goddard Earth Sciences and Technology Center

Amber Reynolds
 NASA's Goddard Space Flight Center

Science Questions for Future Campaigns

- How does hurricane vortex spin up during rapid intensification?
- Where does vortex originate during genesis of tropical cyclones?
- Do convective bursts and hot towers help intensify tropical storms?
- What are best algorithms for dual-frequency microphysics retrievals?

Upcoming Field Campaigns

- Hurricane Severe Storm Sentinel, 2011–2014
- GPM MC3E field campaign, 2011

References

Heymsfield, G.M. *et al.* "High-altitude Imaging Wind and Rain Airborne Profiler (HIWRAP)," NASA Science Technology Conference, College Park, Maryland, 2007.

Heymsfield, G.M. *et al.* "Status of High-altitude Imaging Wind and Rain Airborne Profiler (HIWRAP)," NASA Science Technology Conference, College Park, Maryland, 2008.

Research and Development Instrument Systems

Broadband Lidar for Precision CO₂ Measurement

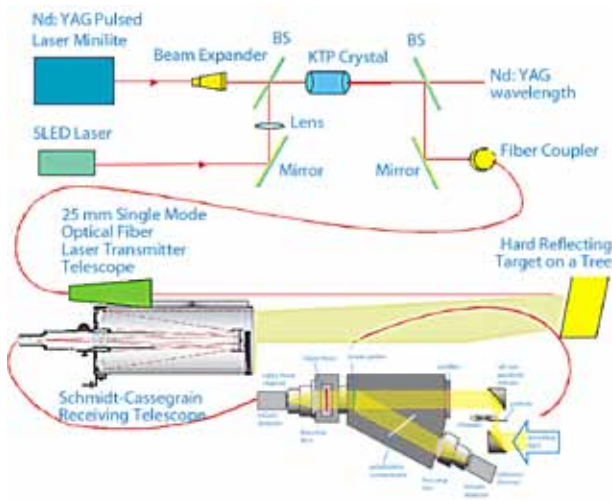

Broadband LIDAR Schematic. The SLED emits a broad output that is tailored to match the CO₂ absorption bands with a band-pass filter. This then is amplified with an OPA and transmitted. The return signal reflected off the ground is collected by a telescope and divided into two channels. One channel serves to normalize the overall intensity of the signals and the second, containing a Fabry-Perot interferometer, responds strongly to changes in the amount of CO₂ along the atmospheric path.

Description

There is a great need for remote sensing measurements of atmospheric carbon dioxide concentration with high spatial and temporal resolution for global and regional studies of the carbon cycle. Such measurements will better resolve the linkage between global warming and anthropogenic CO₂ emissions. In the Decadal Survey of Earth Science, the National Research Council recommended that NASA develop, build, and fly a laser based system for precision measurement of total carbon dioxide column (the ASCENDS mission). The mission demands precision measurements (~400:1) in order to locate sources and sinks. The task is made more difficult due to the strong dependence on changes in atmospheric pressure and temperature of atmospheric carbon dioxide absorption line position, shape, and strength.

Most lidar systems currently under development for remote sensing of atmospheric CO₂ require multiple lasers each operating at different, very narrow bandwidth wavelengths in order to resolve these effects.

The team is currently working on a promising new broadband lidar technique capable of dealing with the complications associated with the aforementioned atmospherically induced variations in CO₂ absorption line position, shape, and strength, while using only a single laser source. Our innovative new approach reduces the number of individual lasers required from three or more to only one, significantly reducing the risk of system failure inherent with a more complex multi-laser scheme and likely reducing overall system cost. This unique technique tremendously reduces the requirement for wavelength stability in the source, further simplifying demands on the laser because the requirement is transferred to a passive solid fused silica Fabry-Perot etalon in the detector/receiver.

Principal Investigator

William S. Heaps
 NASA's Goddard Space Flight Center
 William.S.Heaps@nasa.gov

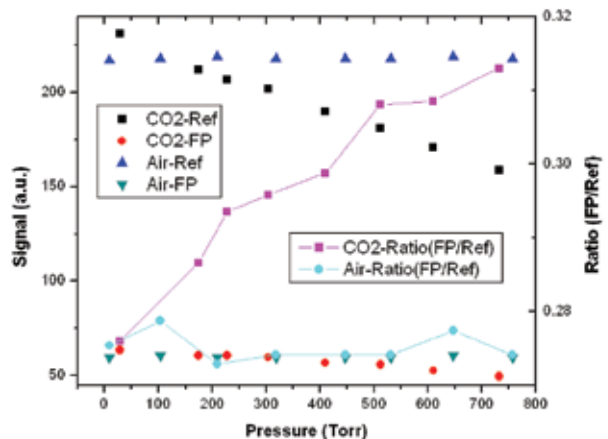

The figure shows the response of the instrument to CO₂ in a 1.4 meter long absorption cell in the lab. As the amount of CO₂ in the cell is increased the ratio of the ref to CO₂ channel increases (red squares) because the CO₂ channel signal gets smaller. When the same test is done using nitrogen instead of CO₂ no change is seen (triangles).

CATS

Cloud-Aerosol Transport Lidar

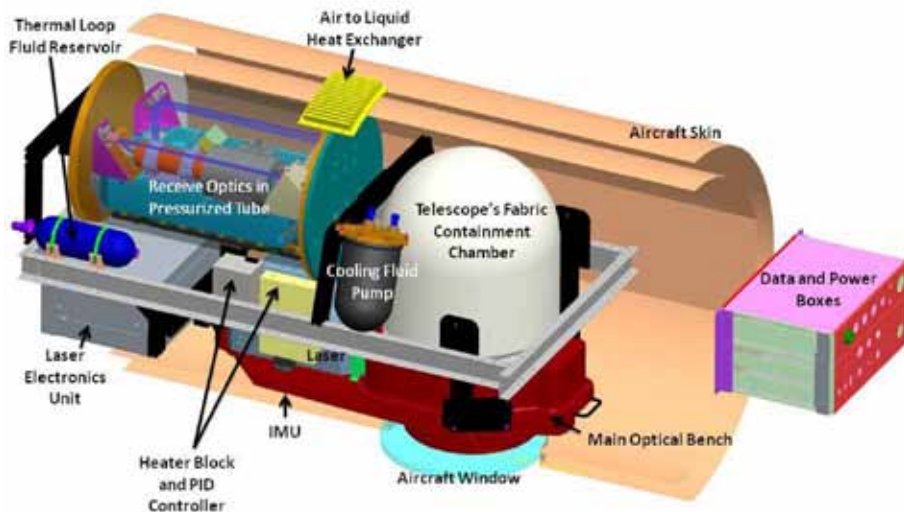

Description

Lidar remote sensing is a proven useful tool for profiling the structure of atmospheric cloud and aerosol features. In addition to basic intensity information, backscattered photons inherently possess other microphysical attributes, such as Doppler shift caused by the mean motion of the scattering medium. Thus, a lidar system capable of resolving the Doppler shifts inherent to atmospheric motions can simultaneously provide information about both the scattering intensity and the particle motion.

The Cloud-Aerosol Transport System (CATS) is a new instrument currently under development. The CATS instrument is a lidar that is both a Doppler lidar and, by its very nature, a high spectral resolution lidar (HSRL). The HSRL aspect of CATS will provide information on cloud and aerosol height, internal structure, and optical properties (e.g., extinction). The Doppler aspect adds capability to derive wind motion, which in turn enables studies of aerosol transport and cloud motion. The technology developed has direct application to future spaceborne missions, such as the proposed Aerosol-Cloud-Ecosystems (ACE) mission and will provide critical validation capability for future missions.

The CATS lidar is an aerosol-based fringe-imaging HSRL/Doppler lidar. The fringe-imaging method measures the Doppler shift of the spectral return by observing the signal spectroscopically (i.e., as a function of wavelength) using a spectral-resolving filter and a multi-element detector. A unique aspect of the fringe-imaging Doppler lidar concept is that it is also, by its very nature, an HSRL. Because the broad

Rayleigh-scattered spectrum is imaged as a nearly flat background (and can be characterized and removed from the total signal) the aerosol scattered signal can be directly and unambiguously measured. The integral of the aerosol-scattered spectrum is, in fact, analogous to the aerosol measurement made with a typical HSRL instrument. It is easily verified that the fringe-imaging lidar provides exactly the same pieces of information as a standard HSRL.

Designed for operation on high-altitude aircraft, the CATS lidar

instrument will provide a combination of backscatter lidar, Doppler lidar, and HSRL. Although it is an HSRL, the single-wavelength CATS lidar is designed to enable aerosol transport studies. In addition, the need to point off-nadir for wind measurements inherently enables cross-track cloud and aerosol measurements.

The CATS lidar will also provide an important technology demonstration for a future global wind system. Global wind measurements from space are recognized as an essential and unfulfilled measurement capability. Although different lidar techniques are being evaluated, no single method is yet mature enough to propose as a definitive space-based system. Because of the numerous difficulties inherent in the measurement, it is unknown if any of the methods currently being evaluated will result in either a successful demonstration of wind measurement technology or a system that is scalable to space platforms. Demonstration flights of the CATS lidar will permit both science and engineering evaluation of an alternate approach to the measurement.

The goal for the CATS lidar is to provide wind measurements with line-of-sight error <2 m/s at resolution of 100 m vertical by approximately 10 seconds horizontal (corresponding to ~ 2 km along track). The cloud/aerosol products of layer boundaries, optical depth, and extinction, similar to the current Cloud Physics Lidar (CPL) data products, will be provided with higher resolutions (30 m vertical by 1 s horizontal).

CATS Instrument Parameters

- Wavelength: 532 nm
- Laser repetition rate: 200 Hz
- Laser energy: 10mJ at 532nm
- Telescope diameter: 8 in
- Total Power: <1500 watts
- Weight: <120 kg
- FOV: 200 microradians
- Vertical resolution: 30 m (aerosol), 100 m (wind)
- Horizontal resolution: 200 m (aerosol), 2 km (wind)

Principal Investigator

Matthew McGill
NASA's Goddard Space Flight Center
matthew.j.mcgill@nasa.gov

Future Plans

- Provide demonstration measurements for ACE for 2010–2011 and beyond.
- Yearly campaigns supporting various Earth Science missions or experiments.

EXRAD ER-2 X-band Radar

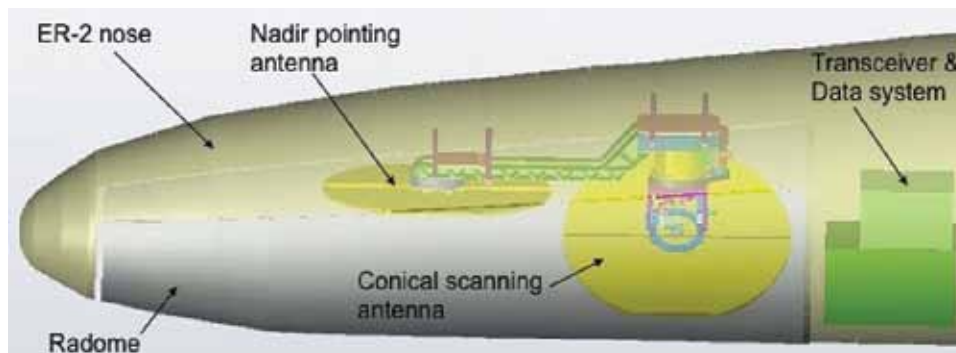

Key EXRAD Facts

- Heritage: EXRAD was developed originally for the Global Hawk but will be used as an EDOP replacement on the ER-2.
- It is a conical scanning single frequency (X-band) Doppler radar with two beams: a fully steerable antenna capable of conical or cross-track scanning, and a nadir-pointing beam.
- The first test flights of EXRAD on the ER-2 will be during fall 2011.
- The emphasis is on wind and precipitation measurements within hurricanes and other weather events.
- Nominal Aircraft Configuration: EXRAD will be configured for the ER-2 radar nose that was used previously for EDOP. It will have one fixed nadir pointing beam and one fully scannable (azimuth and elevation) beam.
- EXRAD URL: <http://bar.gsfc.nasa.gov/>

Description

Following the successful development and field campaigns for the X-band (9.6 GHz) ER-2 Doppler (EDOP) and the W-band (94 GHz) Cloud Radar System (CRS), a compact, lightweight, ER-2 X-band Radar (EXRAD) was developed for studies of tropical storm genesis using the Global Hawk Unmanned Aerial System (UAS). This instrument combines a precipitation radar and a scatterometer that measures both the 3D cloud/precipitation structure and surface winds with fixed nadir and conical/cross-track scanning beams. EXRAD utilizes a high peak power transmitter (TWT), and it is more compact and lighter than the current EDOP. It also employs significantly more processing capability than its predecessors. With EDOP aging and becoming more

difficult to repair, EXRAD was chosen for replacement for the ER-2 EDOP system. It provides additional science capabilities such as scanning and retrieval of the full horizontal wind vector rather than the along-track wind vector provided by EDOP. The onboard processing capabilities are enhancements over its predecessor by using an FPGA-based processor.

EXRAD is to be installed in the ER-2 for initial test flights and data analysis so that it can become an operational tool for studying various types of weather events, atmospheric composition, and water and energy cycle. The ER-2 is an excellent platform for EXRAD involvement in science studies examining convection, convective anvils, and hurricanes, whose tops often extend in the lower stratosphere.

EXRAD Products

- 3D structure below aircraft: radar reflectivity, horizontal winds, ice, and liquid water content.
- Ocean surface winds: Over conical scan swath
- Measurement interval: 37.5 m radial, 600 m along-track
- Measurement accuracy:
 - Reflectivity: 1.0 dBZ
 - Winds 0.5 m/s

EXRAD Parameters:

- Transmitter: TWT
- Peak power: 9.0 kW
- Radio frequency: 9.6 GHz scanning
- Intermediate frequency: 60 MHz
- PRF: 5k/4k kHz
- Pulse Width: 250–2000 ns
- Doppler Range: ± 150 m/s
- Maximum Range Resolution: 37.5 m
- Maximum Num of Range bins: 720

- Averaging Times:
 - 1/60 (scanning)
 - 0.5 (nadir)
- Sensitivity at 10 km:
 - -8 (scanning)
 - -15 (nadir)
- Scanning Rate: 10 rpm
- Antenna size: up to 30 in, flat plate

Principal Investigator

Gerald M. Heymsfield
NASA's Goddard Space Flight Center
Gerald.Heymsfield@nasa.gov

EXRAD Team Members

Lihua Li
NASA's Goddard Space Flight Center

Matthew Mclinden
NASA's Goddard Space Flight Center

Lin Tian
University of Maryland, Baltimore County
Goddard Earth Sciences and Technology Center

Edward Zenker
EZ Software, Inc.

Science Questions for Future Campaigns

- How does hurricane vortex spin up during rapid intensification?
- Where does vortex originate during genesis of tropical cyclones?
- Do hurricane hot towers have rotation and are they contributing to spin up of storms?
- What are the vertical motions in intense convection and how do they compare between regions?

Upcoming Field Campaigns

TBD

Fabry-Perot Based Sensor for Trace Atmospheric Species

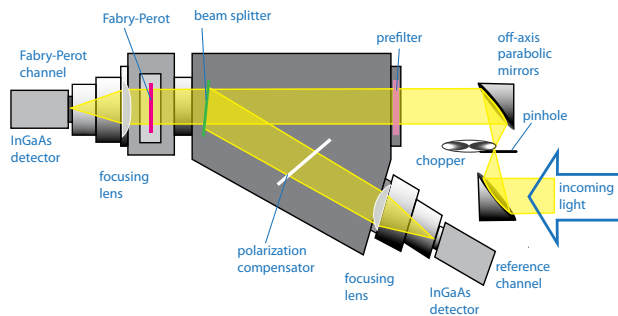

Basic layout of the instrument: Sunlight enters through a chopper, passes the band-pass filter and is split. One part goes directly to a detector and the rest passes through a Fabry-Perot (FP) interferometer and is then detected. The FP can be tuned to transmit only light that is absorbed by the species of interest. The ratio of the signal from the two detectors is very sensitive to changes in the atmospheric abundance of the key species.

Description

Water, carbon dioxide, and methane are the three most potent greenhouse gases in the atmosphere, and it is the increase in the latter two that is believed to be driving climate change

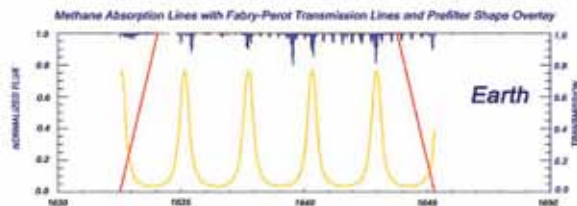

This shows a number of FP passbands (yellow) aligned with methane atmospheric absorption features (blue). When the atmospheric methane changes, the light passing through the FP is strongly affected.

at the present time. It is known that burning fossil fuels is responsible for most of the increase in CO₂ but the source of the increased CH₄ is more problematic.

The sensors that the team is developing are suitable for use from ground based, airborne, or space borne platforms. It is expected that these sensors will play a significant role in elucidating the behavior of these gases from the time of their initial release into the atmosphere until their final removal by the biosphere, the oceans, or some other as yet unknown process.

Principal Investigator

William Heaps
 NASA's Goddard Space Flight Center
 William.S.Heaps@nasa.gov

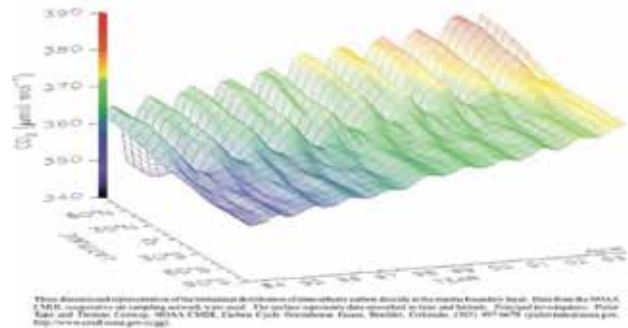

This figure shows the global annual increase in carbon dioxide as measured from ground stations located around the globe. The large semiannual variation in the northern hemisphere is caused by photosynthesis.

GCAS

GEO-CAPE Airborne Simulator

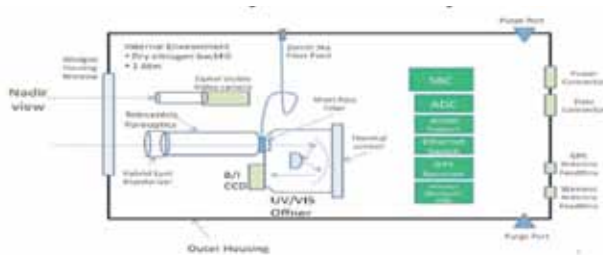

GCAS system concept.

Description:

This is an internal IRAD-funded effort to build an aircraft instrument with specifications that are aligned with the current science requirements of the Geostationary Coastal and Air Pollution Events (GEO-CAPE) mission as recommended by the National Research Council's decadal survey of Earth Science and Applications from Space. The task builds on achievements from our fiscal year 2008, IRAD effort and parallel ongoing efforts in the Atmospheric Chemistry and Dynamics Branch with the Geostationary Spectrograph (GeoSpec) and Airborne Compact Atmospheric Mapper (ACAM) instruments. The effort will consist of building a two-channel UV/VIS/NIR spectrograph suitable for flying onboard either the ER-2 or Global Hawk platforms. The primary objectives of the proposed work are targeted toward future geostationary atmospheric science missions geared toward studies of air quality processes involving trace gas column measurements in the troposphere and stratosphere. However, the spectral coverage provided by the prototype GeoSpec instrument design (developed under a previous IIP effort) also enables measurements of ocean and land/biosphere products, and although the spatial resolution requirements differ, an airborne demonstration will be applicable to both disciplines. One such application envisioned in the NRC Decadal Survey is the Geostationary Coastal and Air Pollution Events (GEO-CAPE) mission for the 2015–2018 timeframe.

Expected Products

- O₃, NO₂, HCHO, SO₂, Aerosol, Ocean Color

GCAS Parameters

Channel 1

- Spectral coverage: 300–540 nm
- Spectral resolution: 0.8 nm
- Spatial coverage: 18 km
- Spatial resolution: 1.0 km
- SNR: 2000:1 (aggregate)

Channel 2

- Spectral coverage: 480–940 nm
- Spectral resolution: 4.0 nm
- Spatial coverage: 18 km
- Spatial resolution: 0.25 km
- SNR: 2000:1 (aggregate)

Principal Investigator

Scott Janz
NASA's Goddard Space Flight Center

Team Members

Duncan Kahle
NASA's Goddard Space Flight Center

Cathy Marx
NASA's Goddard Space Flight Center

Lantrang Nguyen
NASA's Goddard Space Flight Center

Future Plans

The system is planned to be deployed for test flights in early 2012.

In Situ Airborne Formaldehyde Experiment

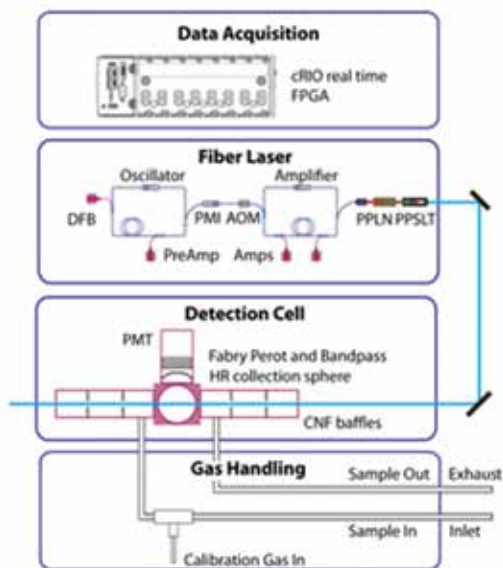

The schematic above shows the various subsystems of the formaldehyde instrument that are currently under development. The instrument is designed to sample ambient air onboard the NASA Global Hawk. The formaldehyde in the sample is detected with laser-induced fluorescence.

Description

Formaldehyde (H_2CO) serves a dual role as a tracer with a short photochemical lifetime (hours to days) and as an intermediate in the photochemistry of organic short-lived species. This versatility makes H_2CO an ideal choice to help constrain the treatment of convection, cloud microphysics, and ozone photochemistry in chemistry-climate models. As a consequence, H_2CO is a primary measurement objective in two proposed missions of the Decadal Survey (GEO-CAPE and GACM). These missions will require airborne in situ measurements of H_2CO from the ground to the lower stratosphere to determine science requirements in order to develop retrieval algorithms and validate. In addition, Venture class and other sub-orbital missions will target species like formaldehyde that can help deduce the link between the transport of urban pollution and the photochemistry and microphysics of the upper troposphere-lower stratosphere (UT/LS).

Our instrument concept uses laser-induced fluorescence (LIF) for the fast time response, high sensitivity, and accurate measurement of H_2CO . We will use a novel multi-stage fiber-amplified tunable pulsed laser. This solid-state approach will dramatically reduce the complexity and cost of the LIF instrument. At the same time, it provides a new capability for the Global Hawk and other NASA high-altitude aircraft (ER-2 and WB57), as well as optimizes sensitivity by applying several new technologies to the fluorescence detection technique.

Principal Investigator

Thomas Hanisco
thomas.hanisco@nasa.gov

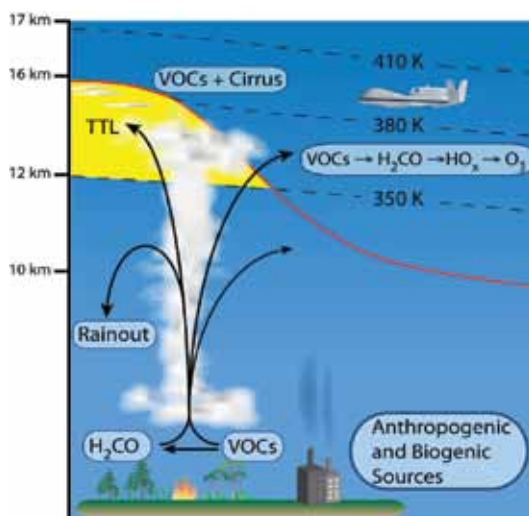

This figure illustrates how convection transports boundary layer pollution to the upper atmosphere where it influences ozone photochemistry and cloud microphysics. The instrument is designed to fly on the Global Hawk to determine the role of pollution on ozone and climate-related studies.

Acronyms

Acronymns

7-SEAS	Seven South East Asian Studies
ACAM	Airborne Compact Atmospheric Mapper
ACE	Advanced Composition Explorer
ACHIEVE	Aerosol-Cloud-Humidity Interactions Exploring and Validating Enterprise
AERONET	Aerosol Robotic Network
ALVICE	Atmospheric Lidar for Validation, Interagency Collaboration and Education
ARM IOP-2000	Atmospheric Radiation Measurement program – cloud Intensive Operational Period – March 2000
AROTAL	Airborne Raman Ozone, Temperature, and Aerosol Lidar
ASCENDS	Active Sensing of CO ₂ Emissions over Nights, Days, and Seasons
AT Lidar	Aerosol and Temperature Lidar
BASE-ASIA	Biomass-burning Aerosols in South-East Asia: Smoke Impact Assessment
CalVal	Calibration and Validation
CATS	Cloud-Aerosol Transport Lidar
CCD	Charge Coupled Device
CLS	Cloud Lidar System
CMOS	Complementary Metal-Oxide Semiconductor
CNES	Centre National d’Etudes Spatiales
COMMIT	Chemical, Optical, and Microphysical Measurements of In situ Troposphere
CoSMIR	Conical Scanning Millimeter-wave Imaging Radiometer
CoSSIR	Compact Scanning Submillimeter-wave Imaging Radiometer
CPL	Cloud Physics Lidar
CRS	Cloud Radar System
CRYSTAL-FACE	Cirrus Regional Study of Tropical Anvils and Cirrus Layers —Florida Area Cirrus Experiment
DDF	Director’s Discretionary Fund
DIAL	Differential Absorption Lidar
DSCOVER	Deep Space Climate Observatory
EDOP	ER-2 Doppler Radar
EPIC	Earth Polychromatic Imaging Camera
EP-TOMS	Earth Probe–Total Ozone Mapping Spectrometer
ER-2	Earth Science Technology Office
ESTO	Earth Sciences Technology Office
EXRAD	ER-2 X-band Radar
FOV	Field of View
FPGA	Field Programmable Gate Array
GACM	Global Atmospheric Composition Mission
GCOS	Global Climate Observing System
GEO-CAPE	Geostationary Coastal and Air Pollution Events

GeoSpec	Geostationary Spectrograph for Earth and Atmospheric Science Applications
GEST	Goddard Earth Sciences and Technology Center
GloPac	Global Hawk Pacific campaign
GLOW	Goddard Lidar Observatory for Winds
GPM	Global Precipitation Measurement
GRUAN	GCOS Reference Upper Air Network
HARGLO	Intercomparison of Wind Profile Systems experiment involving the HARLIE and GLOW instruments
HARLIE	Holographic Airborne Lidar Instrument Experiment
HIWRAP	High-Altitude Imaging and Wind and Rain Airborne Profiler
HOE	Holographic Optical Element
HOPEX	Houston Precipitation Experiment
HSRL	High Spectral Resolution Lidar
ICESat-2	Ice, Cloud, and land Elevation Satellite-2
IHOP	International H ₂ O Project
IIP	Instrument Incubator Program
IRAD	Internal Research and Development
JCET	Joint Center for Earth Systems Technology
JPL	Jet Propulsion Laboratory
KILT	Kiritimati Island Lidar Trailer
LBA	Large Scale Biosphere-Atmosphere Experiment in Amazonia
LIF	Laser Induced Florescence
MABEL	Multiple Altimeter Beam Experimental Lidar
MOHAVE	Measurements of Humidity in the Atmosphere and Validation Experiments
MPLNET	Micro Pulse Lidar Network
NAMMA	NASA African Monsoon Multidisciplinary Analyses
NASA	National Aeronautics and Space Administration
NDACC	Network for the Detection of Atmospheric Composition Change
NDSC	Network for the Detection of Stratospheric Change
NIR	Near Infrared
NPOESS	National Polar-orbiting Operational Environmental Satellite System
NPP	NPOESS Preparatory Project
NRC	National Research Council
OMI	Ozone Monitoring Instrument
PACS	Passive Aerosol and Cloud Suite
PSC	Polar Stratospheric Cloud
RASL	Raman Airborne Spectroscopic Lidar
SAFARI-2000	Southern African Regional Science Initiative 2000
SAGE III	Stratospheric Aerosol and Gas Experiment III

Acronymns

SLED	Storage Latency Estimation Descriptor
SMART	Surface-sensing Measurements for Atmospheric Radiative Transfer
SODISM	SOlar Diameter Imager and Surface Mapper
SOLVE	SAGE III Ozone Loss and Validation Experiment
STROZ LITE	Stratospheric Ozone Lidar Trailer Experiment
SWIR	Short-Wave InfraRed
TC4	Tropical Composition, Cloud, and Climate Coupling
TCSP	Tropical Cloud Systems and Processes
TEFLUN	Texas and Florida Underflight Experiment
THOR	Thickness from Offbeam Returns
TIMS	Technical Information and Management Services
TRL	Technical Readiness Level
TRMM	Tropical Rainfall Measuring Mission
TWiLiTE	Tropospheric Windd Lidar Technology Experiment
TWT	Traveling Wave Tube
UAS	Unmanned Aerial System
UAV	Unmanned Aerial Vehicle
UV	Ultraviolet
UV/VIS	Ultraviolet and Visible
UV-MFRSR	UV Multifilter Rotating Shadowband Radiometer
VIS	Visible Light
VNIR	Visible and Near InfraRed

REPORT DOCUMENTATION PAGE			Form Approved OMB No. 0704-0188		
<p>The public reporting burden for this collection of information is estimated to average 1 hour per response, including the time for reviewing instructions, searching existing data sources, gathering and maintaining the data needed, and completing and reviewing the collection of information. Send comments regarding this burden estimate or any other aspect of this collection of information, including suggestions for reducing this burden, to Department of Defense, Washington Headquarters Services, Directorate for Information Operations and Reports (0704-0188), 1215 Jefferson Davis Highway, Suite 1204, Arlington, VA 22202-4302. Respondents should be aware that notwithstanding any other provision of law, no person shall be subject to any penalty for failing to comply with a collection of information if it does not display a currently valid OMB control number.</p> <p>PLEASE DO NOT RETURN YOUR FORM TO THE ABOVE ADDRESS.</p>					
1. REPORT DATE (DD-MM-YYYY) 01-07-2011		2. REPORT TYPE Technical Publication		3. DATES COVERED (From - To)	
4. TITLE AND SUBTITLE Laboratory for Atmospheres 2010 Instrument Report			5a. CONTRACT NUMBER		
			5b. GRANT NUMBER		
			5c. PROGRAM ELEMENT NUMBER		
6. AUTHOR(S) Laboratory for Atmospheres			5d. PROJECT NUMBER		
			5e. TASK NUMBER		
			5f. WORK UNIT NUMBER		
7. PERFORMING ORGANIZATION NAME(S) AND ADDRESS(ES) Goddard Space Flight Center Greenbelt, MD 20771			8. PERFORMING ORGANIZATION REPORT NUMBER 2011-001157		
9. SPONSORING/MONITORING AGENCY NAME(S) AND ADDRESS(ES) National Aeronautics and Space Administration Washington, DC 20546-0001			10. SPONSORING/MONITOR'S ACRONYM(S)		
			11. SPONSORING/MONITORING REPORT NUMBER NASA-TP-2011-215875		
12. DISTRIBUTION/AVAILABILITY STATEMENT Unclassified-Unlimited, Subject Category: 47 Report available from the NASA Center for Aerospace Information, 7115 Standard Drive, Hanover, MD 21076. (443)757-5802					
13. SUPPLEMENTARY NOTES					
14. ABSTRACT Studies of the atmospheres of our solar system's planets—including our own—require a comprehensive set of observations, relying on instruments on spacecraft, aircraft, balloons, and on the surface. Laboratory personnel define requirements, conceive concepts, and develop instrument systems for spaceflight missions, and for balloon, aircraft, and ground-based observations. Laboratory scientists also participate in the design of data processing algorithms, calibration techniques, and data processing systems. The instrument sections of this report are organized by measurement technique: lidar, passive, in situ and microwave. A number of instruments in various stages of development or modification are also described. This report will be updated as instruments evolve.					
15. SUBJECT TERMS Technical Highlights, Laboratory for Atmospheres, Instrument Systems					
16. SECURITY CLASSIFICATION OF:			17. LIMITATION OF ABSTRACT Unclassified	18. NUMBER OF PAGES 72	19b. NAME OF RESPONSIBLE PERSON William Lau
a. REPORT U	b. ABSTRACT U	c. THIS PAGE U			19b. TELEPHONE NUMBER (Include area code) (301) 614-6332

