

## Linear Back-Drive Differentials

Lighter, smaller, simpler alternatives to gear differentials would be used in limited-rotation applications.

NASA's Jet Propulsion Laboratory,  
Pasadena, California

Linear back-drive differentials have been proposed as alternatives to conventional gear differentials for applications in which there is only limited rotational motion (e.g., oscillation). The finite nature of the rotation makes it possible to optimize a linear back-drive differential in ways that would not be possible for gear differentials or other differentials that are required to be capable of unlimited rotation. As a result, relative to gear differentials, linear back-drive differentials could be more compact and less massive, could contain fewer complex parts, and could be less sensitive to variations in the viscosities of lubricants.

Linear back-drive differentials would operate according to established principles of power ball screws and linear-motion drives, but would utilize these principles in an innovative way. One major characteristic of such mechanisms that would be exploited in linear back-drive differentials is the possibility of designing them to drive or back-drive with similar efficiency and energy input: in other words, such a mechanism can be designed so that a rotating screw can drive a nut linearly or the linear motion of the nut can cause the screw to rotate.

A linear back-drive differential (see figure) would include two collinear shafts connected to two parts that are intended to engage in limited opposing rotations. The linear back-drive differential would also include a nut that would be free to translate along its axis but not to rotate. The inner surface of the nut would be right-hand threaded at one

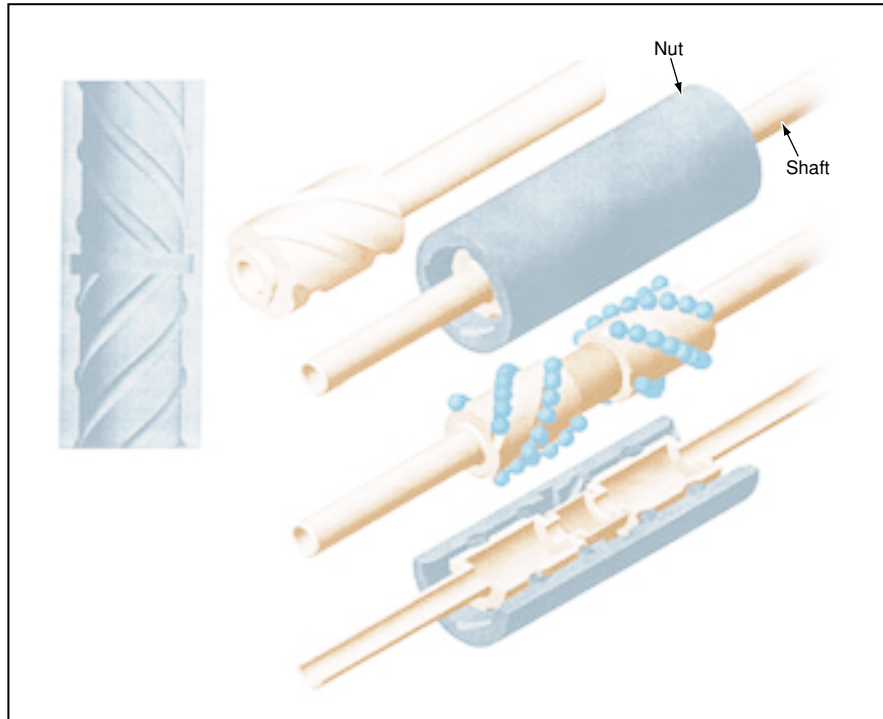

A **Linear Back-Drive Differential** would incorporate components like those of ball screws and linear-motion drives.

end and left-hand threaded at the opposite end to engage corresponding right- and left-handed threads on the shafts. A rotation and torque introduced into the system via one shaft would drive the nut in linear motion. The nut, in turn, would back-drive the other shaft, creating a reaction torque. Balls would reduce friction, making it possible for the

shaft/nut coupling on each side to operate with 90 percent efficiency.

*This work was done by Peter Waydo of Caltech for NASA's Jet Propulsion Laboratory. Further information is contained in a TSP [see page 1].*  
NPO-30366

## Miniature Inchworm Actuators Fabricated by Use of LIGA

These MEMS actuators could be mass-produced at low unit cost.

NASA's Jet Propulsion Laboratory,  
Pasadena, California

Miniature inchworm actuators that would have relatively simple designs have been proposed for applications in which there are requirements for displacements of the order of microns or tens of microns and for the ability to hold their positions when electric power is not applied. The proposed actuators would be members of the class of microelectromechanical systems (MEMS), but would be designed and fabricated following an approach that is somewhat unusual for MEMS.

Like other MEMS actuators, the proposed inchworm actuators could utilize thermoplastic, bimetallic, shape-memory-alloy,

or piezoelectric actuation principles. The figure depicts a piezoelectric inchworm actuator according to the proposal. As in other inchworm actuators, linear motion of an extensible member would be achieved by lengthening and shortening the extensible member in synchronism with alternately clamping and releasing one and then the other end of the member. In this case, the moving member would be the middle one; the member would be piezoelectric and would be shortened by applying a voltage to it. The two outer members would also be piezoelectric; the release of the clamps on the upper or lower end would be achieved

by applying a voltage to the electrodes on the upper or lower ends, respectively, of these members.

Usually, MEMS actuators cannot be fabricated directly on the side walls of silicon wafers, yet the geometry of this actuator necessitates such fabrication. The solution, according to the proposal, would be to use the microfabrication technique known by the German acronym LIGA — "lithographie, galvanofornung, abfornung," which means lithography, electroforming, molding. LIGA involves x-ray lithography of a polymer film followed by selective removal of material to form a three-dimensional pattern from which

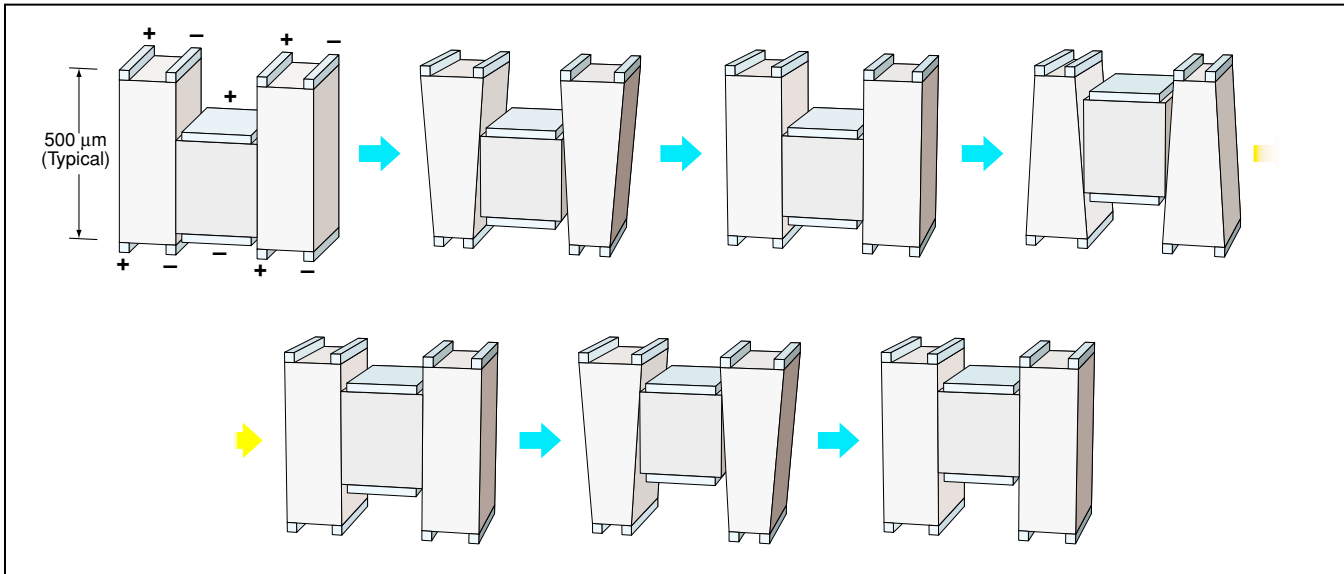

**A Miniature Piezoelectric Inchworm Actuator** fabricated by use of LIGA according to the proposal would have a geometry considerably simpler than that of prior inchworm actuators conventionally assembled from discrete parts.

a mold is made. Among the advantages of LIGA for this purpose are that it is applicable to a broad range of materials, can be used to implement a variety of designs, including those of structures >1 mm high, affords submicron precision, and is amenable to mass production at relatively low unit cost.

Fabrication of the proposed actuators would involve some technological risks — in particular, in the integration of electrode connection lines and placement of actuator elements. It will also be necessary to perform an intensive study of the feasibility of growing piezoelectric crystals onto LIGA molds.

*This work was done by Eui-Hyeok Yang of Caltech for NASA's Jet Propulsion Laboratory. Further information is contained in a TSP [see page 1].*  
NPO-30429

## Books and Reports

### Using ERF Devices To Control Deployments of Space Structures

A report proposes devices containing electrorheological fluids (ERFs) damper for controlling deployments of lightweight, flexible structures in outer space. The structures would include spring members that could be wound or compressed for compact stowage during transport. The ERF based damper would keep the structures compact and/or regulate the speeds with which the structures would spring out for deployment. After deployment, ERF based dampening mechanism could be used to

rigidize the structures or damp their vibrations. An experimental ERF deployment controlled structure described in the report comprised two metal carpenter's measuring tapes sandwiched together, held slightly apart by rubber-band spacers, and placed in a bag filled with an ERF. The viscosity of the ERF varied with the voltage applied to the tapes, such that it was possible to hold the tapes in the wound condition or slow the speed with which they sprung from the wound to the straight condition. The report describes several potential variations on the basic concept of an ERF-controlled structural member, including compartmentalization of the interior volume to prevent total loss of

the ERF in case of a leak and the use of multiple, individually addressable electrode pairs to enable more localized control.

*This work was done by Yoseph Bar-Cohen, Zensheu Chang, Moktar Salama, Xiaoqi Bao, and Stewart Sherrit of Caltech; Christopher Jenkins of SDSM&T; and Aleksandra Vinogradov of Montana State University for NASA's Jet Propulsion Laboratory. To obtain a copy of the report, "Controlled gossamer structures deployment and stability using ERF," see TSP's [page 1].*  
NPO-30587