

around the outside of the tube. The bending block contains a pivot hole to be aligned with the pivot hole in the clamping/radius block. Once the tube has been clamped between the clamping/radius and top clamping blocks, the bending block is placed around the tube, the pivot holes are aligned, and a pivot pin is inserted through the pivot holes.

To bend the tube, the bending block is pivoted so that its semicircular groove slides along the tube, forcing the tube into the curved portion of the

groove in the clamping/radius block. An arm that extends from the clamping/radius block and a similar arm that extends from the bending block provide mechanical advantage for generating bending torques and forces. These arms are actuated by turning a nut on a threaded rod that runs through holes in both arms.

To ensure a precise bend, one should measure the bend angle by use of a protractor at intervals during the bending operation. Even so, it is desirable to calibrate the tool in two ways: (1) measur-

ing and/or calculating the increase in the bend angle for each turn of the nut and (2) measuring and/or calculating the amount of springback. Calibration should facilitate the approach to the final stage of bending (with a slight over-bend to allow for springback) with greater assurance that at the end, the tube will be bent to the desired angle within $\pm 1/2^\circ$.

This work was done by Gary T. Davis of Goddard Space Flight Center. Further information is contained in a TSP (see Page 1). GSC-14412

Multiple-Use Mechanisms for Attachment to Seat Tracks

These could serve as standard or universal seat-track clamps.

Lyndon B. Johnson Space Center, Houston, Texas

A Seat Track Attach Mechanism (SAM) is a multiple-use clamping device intended for use in mounting various objects on the standard seat tracks used on the International Space Station (ISS). The basic SAM design could also be adapted to other settings in which seat tracks are available: for example, SAM-like devices could be used as universal aircraft-seat-track mounting clamps.

A SAM (see figure) is easily installed by inserting it in a seat track, then actuating a locking lever to clamp the SAM to the track. The SAM includes an over-center locking feature that prevents premature disengagement that could be caused by some inadvertent movements of persons or objects in the vicinity.

A SAM can be installed in, or removed from, any position along a seat track, without regard for the locations of the circular access holes. Hence, one or more SAM(s) can be used to mount an object or objects on a track or a pair of tracks in an infinite number of preferred configurations. A SAM can be incorporated into a dual swivel device, so that two of the SAMs can be made to lock onto two side-by-side seat tracks simultaneously, as would be the case in a standard ISS rack bay where two side-by-side racks reside. The main benefit to

using two SAMs in a side-by-side arrangement is to provide a coupled load. By picking up load points on two seat tracks, a coupled loading is created, improving the stability and strength since the load is spread to two seat tracks at a short distance.

This work was done by Martin Fraske and Rich May of Johnson Engineering Corp. for Johnson Space Center. For further information, contact the Johnson Commercial Technology Office at 281-483-3809; commercialization@jsc.nasa.gov. MSC-23299

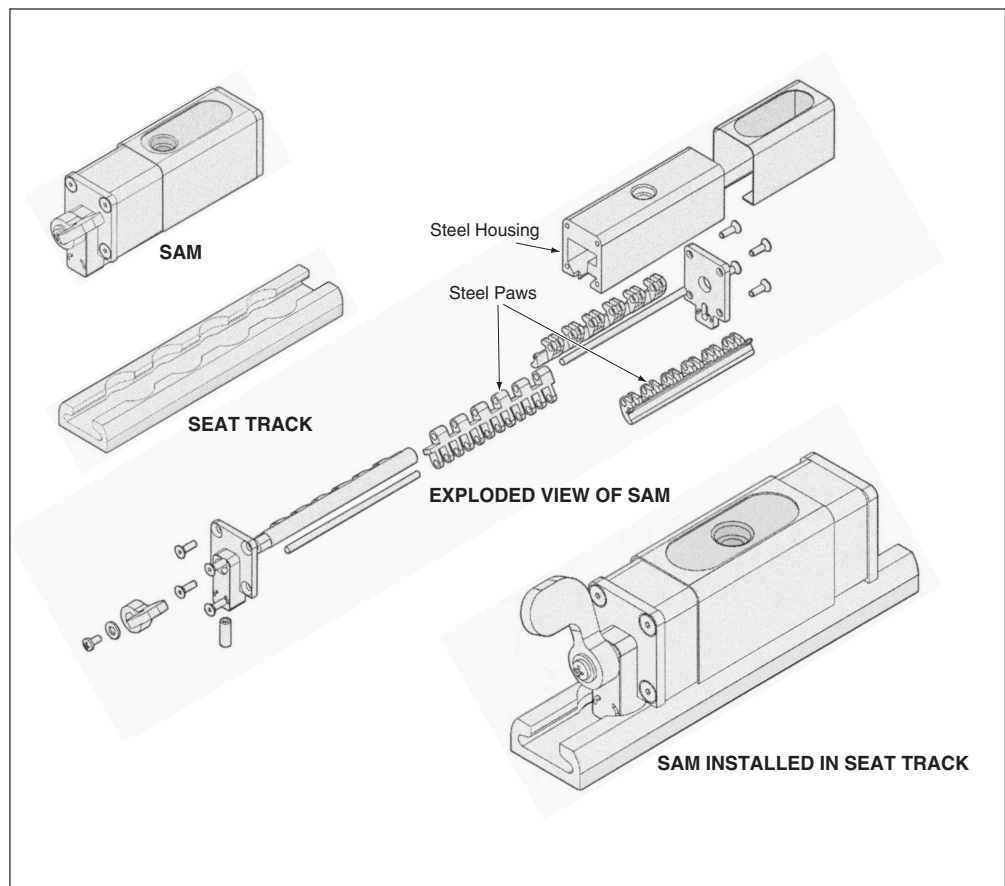

A SAM is Inserted in, and Clamps Onto, a Seat Track. The SAM can be positioned anywhere along the track, without regard for the locations of the access holes.