

## Automated Monitoring With a BSP Fault-Detection Test

This test is sensitive to subtle statistical changes in monitored signals.

Marshall Space Flight Center, Alabama

The figure schematically illustrates a method and procedure for automated monitoring of an asset, as well as a hardware-and-software system that implements the method and procedure. As used here, “asset” could signify an industrial process, power plant, medical instrument, aircraft, or any of a variety of other systems that generate electronic signals (e.g., sensor outputs). In automated monitoring, the signals are digitized and then processed in order to detect faults and otherwise monitor operational status and integrity of the monitored asset. The major distinguishing feature of the present method is that the fault-detection function is implemented by use of a Bayesian sequential probability (BSP) technique. This technique is superior to other techniques for automated monitoring because it affords sensitivity, not only to disturbances in the mean values, but also to very subtle changes in the statistical characteristics (variance, skewness, and bias) of the monitored signals.

In one version of the method, what are monitored are one or more signals from the asset, along with estimates of the signals generated by a parameter-estimator module that uses a stored mathematical model of the asset. In another version of the method, what are monitored are two nominally redundant signals from the asset. In both versions, the differences between corresponding monitored signals are quantified in a residual-error value that is then used for fault detection. A fault-detector module implements the present BSP technique to determine whether the residual-error value is indicative of a signal or asset fault. Next, a fault-manager module decides, on the basis of a series of results generated by the fault-detector module, whether a fault is present. This fault decision is communicated to an operator or to the control subsystem of the asset for corrective action.

In this method, the BSP technique is embodied in a statistical fault-detection algorithm for detecting changes in a residual-error signal. The BSP technique involves the BSP test, which is a statistical

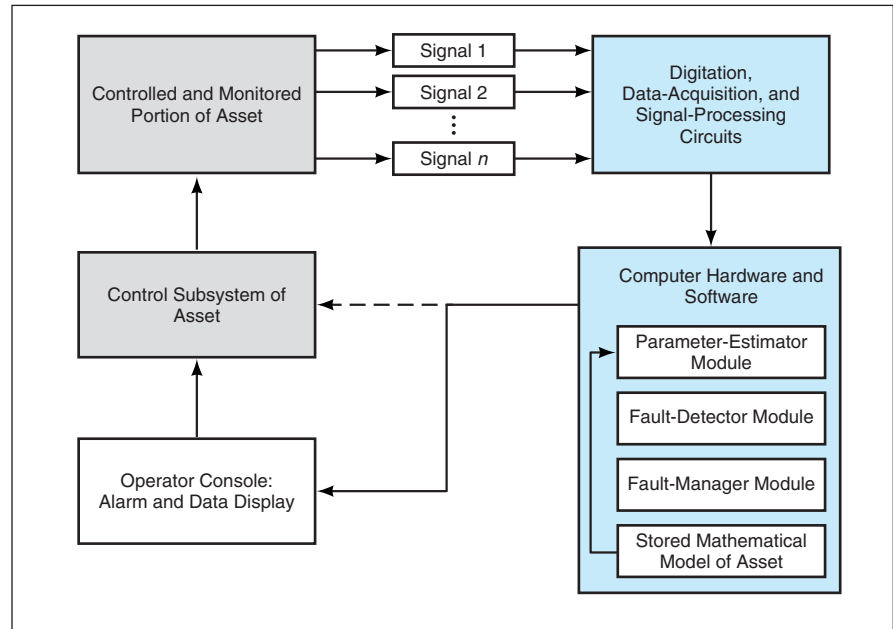

**Monitoring of an Asset is Automated** by a method that incorporates the BSP technique. This method affords sensitivity to subtle changes in statistical characteristics of signals and yields fewer fault-decision errors than does a prior method that incorporates the SPRT technique.

hypothesis test that differs, from the classical fixed-sample hypothesis test, in the way in which statistical observations are employed. In the fixed-sample hypothesis test, a given number of observations are used to select one hypothesis from two or more alternatives. In the BSP test, one examines observations dynamically, one at a time, and selects a hypothesis when adequate evidence is obtained from the series of observations.

The predecessor of the present fault-detection method incorporating the BSP technique is a fault-detection method that incorporates another dynamic statistical fault-detection test known as the sequential probability ratio test (SPRT). A significant shortcoming of SPRT technique is found in the assumptions underlying its mathematical formulation. Specifically, the SPRT technique incorporates the assumption that the residual-error signals are characterized by a Gaussian probability-density function. For residual-error signals that are non-Gaussian, the fault-detector module of the SPRT technique yields unacceptably large false- and missed-alarm rates.

In contrast, in the present method, it is not assumed that the residual-error signals are characterized by a Gaussian probability-density function. Instead, the BSP technique involves the use of any of a number of other techniques for numerically fitting a probability-density function to a residual-error signal distribution that is characteristic of normal operation of the asset. The probability-density function thus derived is then used in the dynamic statistical hypothesis test. As a result, rates of false and missed alarms are smaller; in other words, fault decisions tend to be more accurate than they are in the SPRT technique.

*This work was done by Randall L. Bickford of Expert Microsystems, Inc., and James P. Herzog of Argonne National Laboratory for Marshall Space Flight Center. This technology is immediately available using the SureSense™ Signal Validation System software produced by Expert Microsystems, Inc. For more information, contact the company at (916) 989-2018 or at [expert@expmicosys.com](mailto:expert@expmicosys.com). MFS-31590*