

## Stabilized Fiber-Optic Distribution of Reference Frequency

This system includes subsystems that provide short- and long-term stabilization.

NASA's Jet Propulsion Laboratory,  
Pasadena, California

An optoelectronic system distributes a reference signal of low noise and highly stabilized phase and frequency (100 MHz) from an atomic frequency standard to a remote facility at a distance up to tens of kilometers. The reference signal is transmitted to the remote station as amplitude modulation of an optical carrier signal propagating in an optical fiber. The stabilization scheme implemented in this system is intended particularly to suppress phase and frequency fluctuations caused by vibrations and by expansion and contraction of the optical fiber and other components in diurnal and seasonal heating and cooling cycles.

The system (see figure) comprises several subsystems, the main one being (1) a hydrogen-maser or linear-ion-trap frequency standard in an environmentally controlled room in a signal-processing center (SPC), (2) a stabilized fiber-optic distribution assembly (SFODA), (3) a compensated sapphire oscillator (CSO) in an environmentally controlled room in the remote facility, (4) thermally stabilized distribution amplifiers and cabling from the environmentally controlled room to end users, and (5) performance-measuring equipment. Two of these subsystems, considered as separate entities, were the subjects of prior *NASA Tech Briefs* articles: The SFODA was described in "Improved Stabilization of Delay in an Optical Fiber" (NPO-19353), Vol. 21, No. 2 (February 1997), page 4a; and "Alternative for Stabilization of Delay in an Optical Fiber" (NPO-19075), Vol. 21, No. 2 (February 1997), page 6a. The CSO was described in "Temperature-Compensated Sapphire Microwave Resonator" (NPO-19414), Vol. 20, No. 3 (March 1996), page 14a.

To recapitulate: The SFODA includes the transmitter in which the output of the frequency standard is used to modulate the optical distribution signal, the optical fiber used for long-distance transmission, a compensator reel (a wound, electrically controllable fiber-optic delay line in series with the

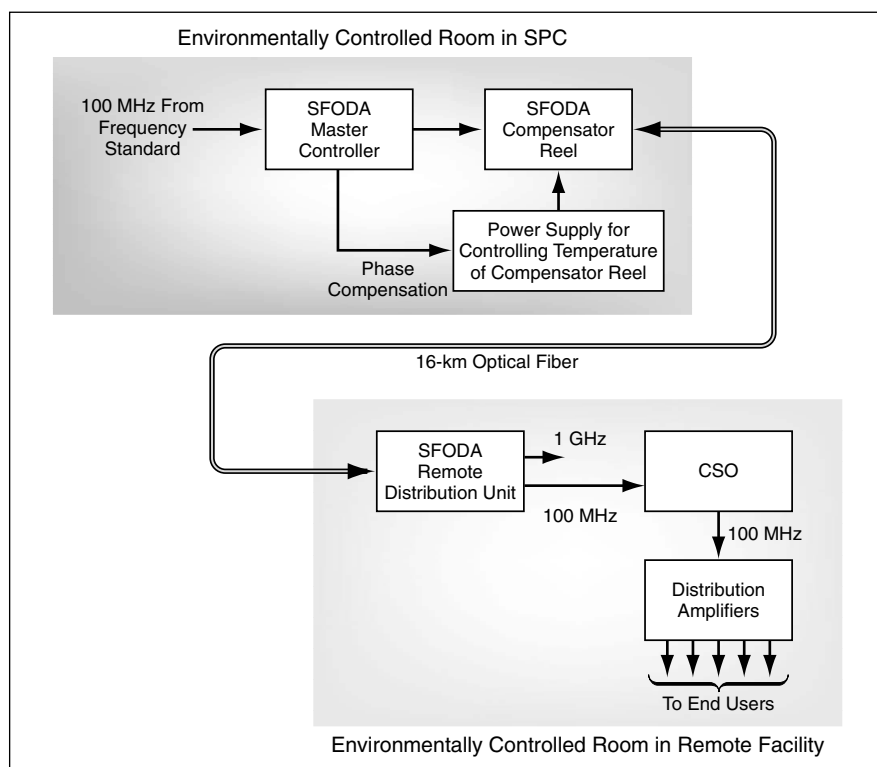

**A Frequency-Standard Signal** is transmitted over a long fiber-optic link augmented with equipment at both ends that stabilizes the output frequency and phase to a high degree.

long-distance optical fiber), signal retransmission optics in the remote facility, and equipment in the SPC that measures the overall round-trip propagation delay of the reference signal and adjusts the temperature of the compensator-reel to maintain the overall propagation delay as nearly constant as possible. The CSO is a sapphire-dielectric ring microwave resonator that operates in a "whispering-gallery" electromagnetic mode and features a paramagnetic-spin-tuned design that provides temperature compensation for ultrahigh frequency stability.

The SFODA and the CSO work in unison in their environmentally controlled rooms to satisfy stringent requirements for stability of frequency and phase: While the SFODA helps to ensure long-term stability, the CSO

helps to ensure short-term stability. In this system, the 100-MHz signal is first multiplied to 1 GHz before applying it as modulation to the optical carrier. At the remote site, a low-noise 100-MHz voltage-controlled oscillator (VCO) that is part of the SFODA is phase-locked to the 1-GHz signal to preserve coherence with the frequency standard. In turn, the CSO is phase-locked to the output of the VCO. The cleaned-up signal is then measured and distributed to end users.

*This work was done by Malcolm Calhoun, Robert Tjoelker, William Diener, G. John Dick, Rabi Wang, and Albert Kirk of Caltech for NASA's Jet Propulsion Laboratory. For further information, access the Technical Support Package (TSP) free online at [www.nasatech.com](http://www.nasatech.com) NPO-30490*

## Delay/Doppler-Mapping GPS-Reflection Remote-Sensing System

This system offers capabilities beyond those of prior GPS-reflection remote-sensing systems.

NASA's Jet Propulsion Laboratory,  
Pasadena, California

A radio receiver system that features enhanced capabilities for remote sensing by use of reflected Global Positioning System (GPS) signals has been devel-

oped. This system was designed primarily for ocean altimetry, but can also be used for scatterometry and bistatic synthetic-aperture radar imaging.

Moreover, it could readily be adapted to utilize navigation-satellite systems other than the GPS, including the Russian Global Navigation Satellite System

(GLONASS) and the proposed European Galileo system.

This remote-sensing system offers both advantages and disadvantages over traditional radar altimeters: One advantage of GPS-reflection systems is that they cost less because there is no need to transmit signals. Another advantage is that there are more simultaneous measurement opportunities — one for each GPS satellite in view. The primary disadvantage is that in comparison with radar signals, GPS signals are weaker, necessitating larger antennas and/or longer observations.

This GPS-reflection remote-sensing system was tested in aircraft and made to record and process both (1) signals coming directly from GPS satellites by means of an upward-looking antenna and (2) GPS signals reflected from the ground by means of a downward-looking antenna. In addition to performing conventional GPS processing, the system records raw signals for postprocessing as required.

The figure schematically depicts the airborne equipment part of the present system. Four synchronized GPS receiver front ends, each connected to a separate antenna, sample the complex (in-phase and quadrature) GPS L1 (1,575.42 MHz) and L2 (1,227.6) signals at a rate of 20.456 MHz. The sampling clock in one receiver front end is used as a master clock for synchronizing all four receivers and two digital data recorders. The raw samples are fed through the digital data recorders for storage on two 300-GB arrays of hard disks. Subsequently, the digitized samples are processed by software that performs functions similar to those of GPS hardware receivers, plus additional processing of the reflected signals.

Whereas prior such systems have utilized the delay information in the GPS signals, this system also utilizes the Doppler shifts of the signals to increase

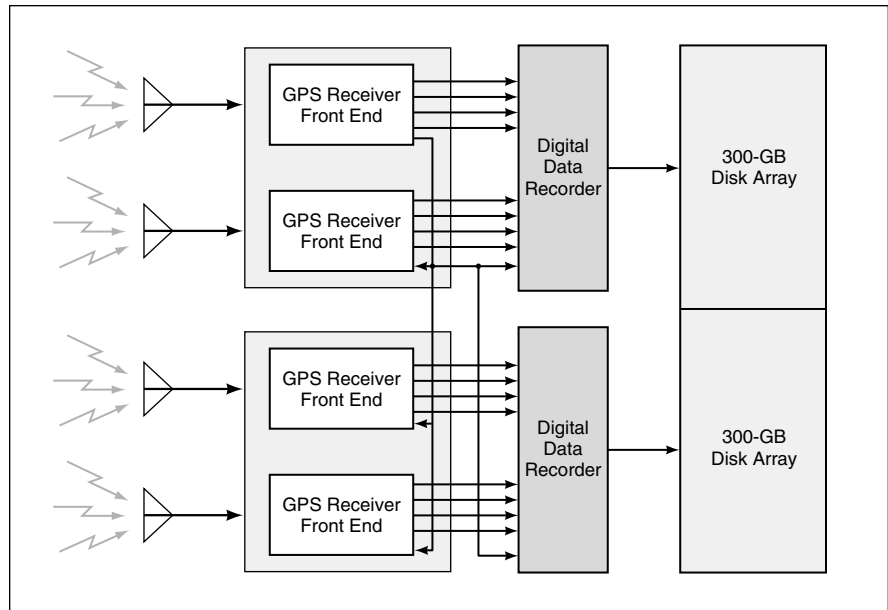

**This Airborne Subsystem** samples direct and reflected GPS signals and records the resulting data. Later, the data are uploaded to general-purpose computers for processing by software that performs a variety of standard and custom GPS receiver functions.

precision and extract additional information about the terrain or water surface under observation. The system offers 160 to 320 times the data-collection bandwidth of prior GPS-reflection remote-sensing systems. Moreover, unlike other such systems that do not have reprocessing capability, this system affords much greater flexibility because it can be made to reprocess the recorded signal data at will.

The software signal-processing functions in this system include detection of signals; tracking of phases and delays; mapping of delay, Doppler, and delay/Doppler waveforms; dual-frequency (L1 and L2) processing; coherent integrations as short as 125  $\mu$ s; decoding of navigation messages; and precise time tagging of observable quantities. The software can perform these functions on all detectable satellite signals without dead time. Custom signal-processing

features can easily be included: For example, in principle, data collected over the ocean by this system can be processed to extract mean sea height, wind speed and direction, and significant wave height; data collected over land can be processed to extract measures of soil moisture and biomass; and data collected over ice can be processed to obtain estimates of the ice age, thickness, and surface density.

*This work was done by Stephen Lowe, Peter Kroger, Garth Franklin, John LaBrecque, Jesse Lerma, Michael Lough, Martin Marcin, Ronald Muellerschoen, Donovan Spitzmesser, and Lawrence Young of Caltech for NASA's Jet Propulsion Laboratory. For further information, access the Technical Support Package (TSP) free on-line at [www.nasatech.com](http://www.nasatech.com). NPO-30385*

## Ladar System Identifies Obstacles Partly Hidden by Grass

A robot moving cross country (e.g., an agricultural robot) could avoid obstacles.

A ladar-based system now undergoing development is intended to enable an autonomous mobile robot in an outdoor environment to avoid moving toward trees, large rocks, and other obstacles that are partly hidden by tall grass. The design of the system incor-

porates the assumption that the robot is capable of moving through grass and provides for discrimination between grass and obstacles on the basis of geometric properties extracted from ladar readings as described below.

The system (see figure) includes a

*NASA's Jet Propulsion Laboratory, Pasadena, California*

ladar system that projects a range-measuring pulsed laser beam that has a small angular width of  $\Delta$  radians and is capable of measuring distances of reflective objects from a minimum of  $d_{\min}$  to a maximum of  $d_{\max}$ . The system is equipped with a rotating mirror that