



Design and Test Plans for a Non-Nuclear Fission Power System Technology Demonstration Unit

*Lee Mason, Donald Palac, and Marc Gibson
Glenn Research Center, Cleveland, Ohio*

*Michael Houts
Marshall Space Flight Center, Huntsville, Alabama*

*John Warren
Headquarters, Washington, DC*

*Jim Werner
Idaho National Laboratory, Idaho Falls, Idaho*

*David Poston
Los Alamos National Laboratory, Los Alamos, New Mexico*

*Arthur Lou Qualls
Oak Ridge National Laboratory, Oak Ridge, Tennessee*

*Ross Radel
Sandia National Laboratories, Albuquerque, New Mexico*

*Scott Harlow
Department of Energy, Germantown, Maryland*

NASA STI Program . . . in Profile

Since its founding, NASA has been dedicated to the advancement of aeronautics and space science. The NASA Scientific and Technical Information (STI) program plays a key part in helping NASA maintain this important role.

The NASA STI Program operates under the auspices of the Agency Chief Information Officer. It collects, organizes, provides for archiving, and disseminates NASA's STI. The NASA STI program provides access to the NASA Aeronautics and Space Database and its public interface, the NASA Technical Reports Server, thus providing one of the largest collections of aeronautical and space science STI in the world. Results are published in both non-NASA channels and by NASA in the NASA STI Report Series, which includes the following report types:

- **TECHNICAL PUBLICATION.** Reports of completed research or a major significant phase of research that present the results of NASA programs and include extensive data or theoretical analysis. Includes compilations of significant scientific and technical data and information deemed to be of continuing reference value. NASA counterpart of peer-reviewed formal professional papers but has less stringent limitations on manuscript length and extent of graphic presentations.
- **TECHNICAL MEMORANDUM.** Scientific and technical findings that are preliminary or of specialized interest, e.g., quick release reports, working papers, and bibliographies that contain minimal annotation. Does not contain extensive analysis.
- **CONTRACTOR REPORT.** Scientific and technical findings by NASA-sponsored contractors and grantees.

- **CONFERENCE PUBLICATION.** Collected papers from scientific and technical conferences, symposia, seminars, or other meetings sponsored or cosponsored by NASA.
- **SPECIAL PUBLICATION.** Scientific, technical, or historical information from NASA programs, projects, and missions, often concerned with subjects having substantial public interest.
- **TECHNICAL TRANSLATION.** English-language translations of foreign scientific and technical material pertinent to NASA's mission.

Specialized services also include creating custom thesauri, building customized databases, organizing and publishing research results.

For more information about the NASA STI program, see the following:

- Access the NASA STI program home page at <http://www.sti.nasa.gov>
- E-mail your question via the Internet to help@sti.nasa.gov
- Fax your question to the NASA STI Help Desk at 443-757-5803
- Telephone the NASA STI Help Desk at 443-757-5802
- Write to:
NASA Center for AeroSpace Information (CASI)
7115 Standard Drive
Hanover, MD 21076-1320



Design and Test Plans for a Non-Nuclear Fission Power System Technology Demonstration Unit

*Lee Mason, Donald Palac, and Marc Gibson
Glenn Research Center, Cleveland, Ohio*

*Michael Houts
Marshall Space Flight Center, Huntsville, Alabama*

*John Warren
Headquarters, Washington, DC*

*Jim Werner
Idaho National Laboratory, Idaho Falls, Idaho*

*David Poston
Los Alamos National Laboratory, Los Alamos, New Mexico*

*Arthur Lou Qualls
Oak Ridge National Laboratory, Oak Ridge, Tennessee*

*Ross Radel
Sandia National Laboratories, Albuquerque, New Mexico*

*Scott Harlow
Department of Energy, Germantown, Maryland*

Prepared for the
Nuclear and Emerging Technologies for Space (NETS-2011)
cosponsored by the ANS Aerospace Nuclear Science and Technology Division, the ANS Trinity Section,
and the AIAA
Albuquerque, New Mexico, February 7–10, 2011

National Aeronautics and
Space Administration

Glenn Research Center
Cleveland, Ohio 44135

Acknowledgments

This work was performed by the fission power system team for the Exploration Technology Development Program, which is now transitioning to the Enabling Technology Development and Demonstration Program. It should be noted that the author list includes the main point-of-contact from each of the partner organizations, but that many more individuals at those organizations contribute toward making the project successful.

This report contains preliminary findings,
subject to revision as analysis proceeds.

Trade names and trademarks are used in this report for identification
only. Their usage does not constitute an official endorsement,
either expressed or implied, by the National Aeronautics and
Space Administration.

Level of Review: This material has been technically reviewed by technical management.

Available from

NASA Center for Aerospace Information
7115 Standard Drive
Hanover, MD 21076-1320

National Technical Information Service
5301 Shawnee Road
Alexandria, VA 22312

Available electronically at <http://www.sti.nasa.gov>

Design and Test Plans for a Non-Nuclear Fission Power System Technology Demonstration Unit

Lee Mason, Donald Palac, and Marc Gibson
National Aeronautics and Space Administration
Glenn Research Center
Cleveland, Ohio 44135

Michael Houts
National Aeronautics and Space Administration
Marshall Space Flight Center
Huntsville, Alabama 35812

John Warren
National Aeronautics and Space Administration
Headquarters
Washington, DC 20546

Jim Werner
Idaho National Laboratory
Idaho Falls, Idaho 83415

David Poston
Los Alamos National Laboratory
Los Alamos, New Mexico 87545

Arthur Lou Qualls
Oak Ridge National Laboratory
Oak Ridge, Tennessee 37831

Ross Radel
Sandia National Laboratories
Albuquerque, New Mexico 87185

Scott Harlow
Department of Energy
Germantown, Maryland 20874

Abstract

A joint National Aeronautics and Space Administration (NASA) and Department of Energy (DOE) team is developing concepts and technologies for affordable nuclear Fission Power Systems (FPSs) to support future exploration missions. A key deliverable is the Technology Demonstration Unit (TDU). The TDU will assemble the major elements of a notional FPS with a non-nuclear reactor simulator (Rx Sim) and demonstrate system-level performance in thermal vacuum. The Rx Sim includes an electrical resistance heat source and a liquid metal heat transport loop that simulates the reactor thermal interface and expected dynamic response. A power conversion unit (PCU) generates electric power utilizing the liquid metal heat source and rejects waste heat to a heat rejection system (HRS). The HRS includes a pumped water heat removal loop coupled to radiator panels suspended in the thermal-vacuum facility. The basic test plan is to subject the system to realistic operating conditions and gather data to evaluate performance sensitivity, control stability, and response characteristics. Upon completion of the

testing, the technology is expected to satisfy the requirements for Technology Readiness Level 6 (System Demonstration in an Operational and Relevant Environment) based on the use of high-fidelity hardware and prototypic software tested under realistic conditions and correlated with analytical predictions.

Nomenclature

ALIP	annular linear induction pump
DAS	data acquisition system
DOE	Department of Energy
ELS	electric load simulator
FCS	facility cooling system
FPS	Fission Power System
FSP	Fission Surface Power
HRS	heat rejection system
INL	Idaho National Laboratory
JIMO	Jupiter Icy Moons Orbiter
LANL	Los Alamos National Laboratory
MSFC	Marshall Space Flight Center
NASA	National Aeronautics and Space Administration
PMAD	power management and distribution
ORNL	Oak Ridge National Laboratory
PCU	power conversion unit
PID	proportional-integral derivative
Rx Sim	reactor simulator
SNL	Sandia National Laboratories
TDU	Technology Demonstration Unit
VF6	vacuum facility 6

Fission Power Project

The Fission Power System (FPS) technology project is a joint collaboration of the National Aeronautics and Space Administration (NASA) and Department of Energy (DOE) aimed at establishing the technology readiness of space reactor power systems for future exploration missions (Refs. 1 and 2). The FPS project resides under the Enabling Technology Development and Demonstration Program, one of five initial demonstration projects selected for near-term development. Up until recently, the project was focused on lunar and Mars surface power applications. The current effort has been expanded to address other fission power applications that may be derived from NASA's new broader, more flexible mission path. The primary project goals, as defined during the surface mission focus, remain essentially unchanged: 1) develop concepts that meet the expected power requirements at reasonable cost with added benefits over other options, 2) establish a hardware-based technical foundation for design concepts and reduce overall development risk, 3) reduce the cost uncertainties and establish greater credibility for flight system cost estimates, and 4) generate the key products to allow NASA decision makers to consider fission systems as a preferred option for flight development.

The former Fission Surface Power (FSP) project was initiated in 2006 as the NASA Prometheus Program and the Jupiter Icy Moons Orbiter (JIMO) mission were phased out. As a first step, NASA Headquarters commissioned the Affordable Fission Surface Power System Study to evaluate the potential for an affordable FSP development approach (Ref. 3). With a cost-effective FSP strategy identified, the

FSP team evaluated design options and selected a Preliminary Reference Concept to guide technology development (Refs. 4 to 6). Since then, the FSP preliminary reference concept has served as a point-of-departure for several NASA mission architecture studies examining the use of nuclear power (Ref. 7) and has provided the foundation for a series of “pathfinder” hardware tests (Refs. 8 to 12). The project goal is a Technology Demonstration Unit (TDU) integrated system test using full-scale components and a non-nuclear reactor simulator.

The fission power team consists of Glenn Research Center (GRC), Marshall Space Flight Center (MSFC), and the DOE National Laboratories at Los Alamos (LANL), Idaho (INL), Oak Ridge (ORNL), and Sandia (SNL). The project is organized into two main elements: concept definition and risk reduction. Under concept definition, the team performs trade studies, develops analytical tools, and formulates system concepts. Under risk reduction the team develops hardware prototypes and conducts laboratory-based testing.

Technology Demonstration Unit Overview

The TDU is an end-to-end system test of a reactor simulator (Rx Sim), power conversion unit (PCU), and heat rejection system (HRS) in thermal vacuum. The TDU is intended to demonstrate the major elements of a notional fission power system using a non-nuclear heat source. The Rx Sim includes an electrical resistance heat source and a liquid metal (sodium potassium or NaK) heat transport loop that simulate the reactor thermal interface and expected dynamic response. The PCU generates electric power utilizing the heated liquid metal and rejects waste heat to the HRS. The HRS includes a pumped water heat removal loop coupled to radiator panels suspended in the thermal-vacuum facility. An intermediate test configuration, prior to the installation of the HRS, includes a facility cooling system (FCS) to reject PCU waste heat utilizing an external air-cooled heat exchanger. The data acquisition and control, and power management and distribution (PMAD) equipment would be external to the vacuum facility and provide prototypic functionality using commercially available, rack-mounted components.

The TDU was devised to demonstrate the technology for a 40-kWe FPS and includes one of four full-scale power conversion strings, permitting the test system to produce 10 kWe under nominal conditions. The technology is broadly applicable to fission power systems with pumped liquid-metal-cooled reactors and dynamic power conversion for power levels up to at least 100 kWe. The test configuration is based on the surface power application with a below-grade reactor core beneath a vertical truss structure that supports the NaK heat transport components, PCU, and HRS water pump as shown in Figure 1. The two-sided vertical radiator panels are mounted adjacent to the truss and supported by a central monorail from the ceiling of the vacuum chamber. The entire Rx Sim, PCU, and HRS assembly is contained in a 21-m-long horizontal vacuum chamber at NASA GRC, known as vacuum facility 6 (VF6). Separate external computer controllers are anticipated for the Rx Sim, PCU, and HRS to accommodate checkout testing at supplier facilities prior to integration at GRC. The separate controllers would be integrated at GRC to permit data exchange to a central data acquisition system via an Ethernet communications network.



Figure 1.—TDU test layout with the Core Simulator, NaK heat transport components, and Stirling PCU in the vertical truss and the Six HRS radiators supported by the central monorail.

Test Objectives

The primary objective of the TDU is to demonstrate the technology readiness of an integrated FPS using a non-nuclear heat source. Upon completion of the testing, the technology is expected to satisfy the requirements for Technology Readiness Level 6 (System Demonstration in an Operational and Relevant Environment). This is based on the use of high-fidelity hardware and prototypic software tested under realistic conditions and correlated with analytical predictions. Many past space reactor projects have produced impressive reports and insightful analyses, but few have assembled prototype components into a system and demonstrated operational performance.

The nuclear reactor core will be simulated in the TDU to avoid the complexity of a nuclear heated test. The FSP design uses relatively mature reactor technology based on terrestrial heritage permitting the reactor development to be deferred to a follow-on flight program, if NASA chooses to pursue the option further. Some nuclear-related technology development will be conducted in parallel with the TDU including reflector control drive testing, shield development, and material and component irradiation testing. Some of the major challenges that the TDU testing will address are the liquid metal heat transport, electric power generation, and waste heat removal. The basic test plan is to subject the system to realistic operating conditions and gather data to evaluate performance sensitivity, control stability, and response characteristics. The TDU will not demonstrate system lifetime or launch and landing survivability, since both of those items are better addressed in a flight program when the requirements are better defined and the design is more mature.

Block Diagram

The TDU block diagram is shown in Figure 2. The Rx Sim includes a core simulator and a primary NaK heat transport loop. The core simulator includes a series of pin-type electrical resistance heating elements arranged to represent the reactor fuel pin bundle. The NaK loop includes an electromagnetic pump and volume accumulator. A NaK fill and drain system provides the capability for charging and discharging the NaK loop. An Rx Sim controller collects data, relays command signals, and supplies electric power for the Rx Sim components. The Rx Sim controller provides the means to control core simulator NaK outlet temperature and NaK flow rate. It also includes the software to simulate the expected temperature-reactivity feedback dynamics of a fission reactor.

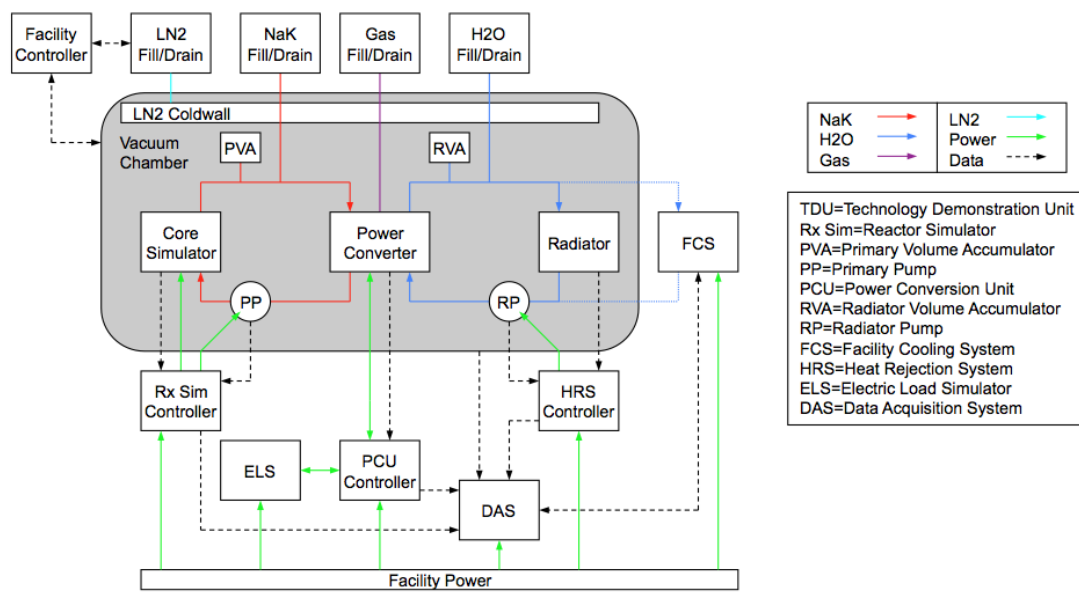

Figure 2.—TDU block diagram with the fluid, electrical, and data interfaces shown for the major TDU components.

The PCU consists of the power converter, PCU controller, and gas fill and drain system. The power converter includes a NaK-to-gas heat exchanger for heat input and a gas-to-water heat exchanger for waste heat removal. Two power conversion technologies were considered during early design studies: closed Brayton and free-piston Stirling. The Brayton option, developed by Barber Nichols, included a single heat engine with a rotating turbine-alternator-compressor and gas-to-gas recuperator (Ref. 13). The Stirling option by Sunpower utilized two free-piston heat engines with integral regenerators and linear alternators in an opposed configuration to balance vibration (Ref. 14). Following the design studies, the Stirling option was selected for fabrication and test. The gas fill and drain system provides the capability for charging and discharging the Stirling converter's helium working fluid. The PCU controller collects data, relays command signals, and supplies startup electric power for the converter. It also processes the electric output of the converter providing alternating current (ac)–direct current (dc) conversion, parasitic load control, and voltage regulation.

The HRS consists of the radiator, pumped water heat transport loop, and HRS controller. The radiators are two-sided vertical panels with embedded titanium-water heat pipes. The radiator panels include a manifold with heat exchangers to transfer heat from the pumped water loop to the heat pipe evaporators. The heat pipes transfer the heat to the condenser section and then to the panel surface where it is radiated to the walls of the thermal-vacuum chamber. The water heat transport loop provides direct cooling of the power converter and includes a pump and volume accumulator. The HRS controller collects data, relays command signals, controls the pump flow rate, and supplies pump power. Prior to the HRS installation, the FCS will provide waste heat removal for the power converter. The FCS will also utilize water coolant and will include all of the equipment to circulate the water and remove the waste heat using a commercial air-cooled heat exchanger located outside the vacuum chamber. The water fill and drain provides the capability for charging and discharging the water loop with either the HRS or FCS-based test configuration.

The balance of the test system is associated with the facility. The facility includes the vacuum chamber (VF6), liquid nitrogen (LN₂) cold wall, LN₂ fill and drain system, facility controller, facility power, electric load simulator (ELS), and data acquisition system (DAS). The vacuum chamber is a 21-m-long by 7.6-m-diameter horizontal cylindrical tank with cryogenic pumps. The LN₂ cold wall extends along the center 16.2 m of the chamber length and covers all but the bottom 60° of the circumference. The LN₂ sections would operate at LN₂ temperature (77 K) while the bottom and end-cap sections would be at ambient temperature (300 K). The LN₂ fill and drain provides the capability for charging and discharging the cold wall. The facility controller provides the operations interface for the vacuum chamber and LN₂ cold wall. The facility power supplies electric power for the TDU components with availability of 110, 220, 440, and 208 V service. The ELS receives the regulated electric power from the PCU controller and provides a user interface for switching typical loads. The ELS also provides the power bus for starting the power converter. The DAS provides a central data collection node for the Rx Sim, PCU, and HRS controllers as well as facility instrumentation. A communication network is envisioned that will permit the transfer of data between the various controllers and the DAS.

Design Requirements

A detailed TDU Design Specification containing system, subsystem, and component design requirements was generated to guide hardware development. The specified values are based on the expected operating conditions of the reference FSP system concept defined in Reference 5. In some cases the values are modified based on the single-string test configuration and/or the inability to represent the flight system with less than fully prototypic test articles. The requirements are based on the Stirling PCU selection and are based on nominal operating conditions with margin, if appropriate. The TDU test plan will include test points to evaluate off-nominal conditions. In some cases where those conditions could be predicted, a range of values is specified.

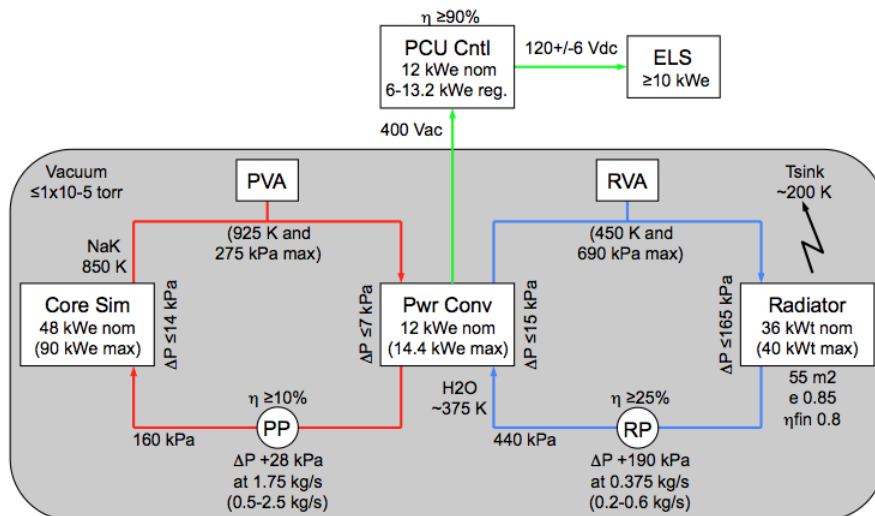

Figure 3.—Key performance requirements for the major TDU components.

A summary of the key TDU performance requirements is shown in Figure 3. The core simulator nominal input power is 48 kWe producing a primary NaK outlet temperature of 850 K. The Stirling PCU generates 12 kWe and transfers 36 kWt to the water heat removal loop with an inlet temperature of approximately 375 K. A 55-m² radiator with an outlet temperature of 375 K rejects the 36 kWt to the thermal-vacuum chamber cold sink of 200 K. The 400 Vac Stirling alternator output power is processed through an electrical controller that delivers 10 kWe to the ELS at 120 Vdc. The TDU system is intended to function over a wide range of operating points and transient conditions, representative of what could occur in a flight mission. The primary test variables are core simulator power, primary NaK flow rate, Stirling piston amplitude, water flow rate, sink temperature, and user load demand.

Development Status

The TDU System Requirements Review was held in December 2008 at which time a draft TDU System Specification was generated to guide the design process. In February 2009, the TDU Preliminary Design Review formally kicked off the development of the TDU. An independent review panel evaluated the readiness of the TDU system and component designs to proceed to final design. In May 2009, a second independent panel reviewed the final designs and fabrication readiness of the main TDU components: core simulator, NaK pump, NaK accumulator, intermediate heat exchanger, and PCU. An additional product of the May review was a final management-approved TDU System Specification. The design formulation process culminated with the TDU System Final Design Review in October 2009 where a third independent panel evaluated the system design readiness and recommended that the project proceed. All major components of the TDU are now in development, and test facility preparations are in process. In October 2010, project budget reductions forced the deletion of the intermediate NaK loop, which was originally included in the TDU to reflect the expected surface power configuration. Work is proceeding on a single NaK loop Rx Sim that still meets the technical objectives. The paragraphs below provide a brief status on the Rx Sim and PCU.

The core simulator, shown in Figure 4, includes 36 individual pin-type electrical-resistance heating elements arranged in a bundle that represents the reactor core plus one center pin allocated for instrumentation wires. The custom heater elements, developed by MSFC, are made of graphite with a stainless steel sleeve and a helium cover gas. The heater geometry and thermal performance is intended to approximate a reactor fuel pin. Testing at MSFC has demonstrated long-term heater operation at power levels in excess of 2.5 kWe. Electric power is provided to the core simulator through 12 separate power supplies with three heater elements in series per circuit. The 37 pins are contained in a stainless steel

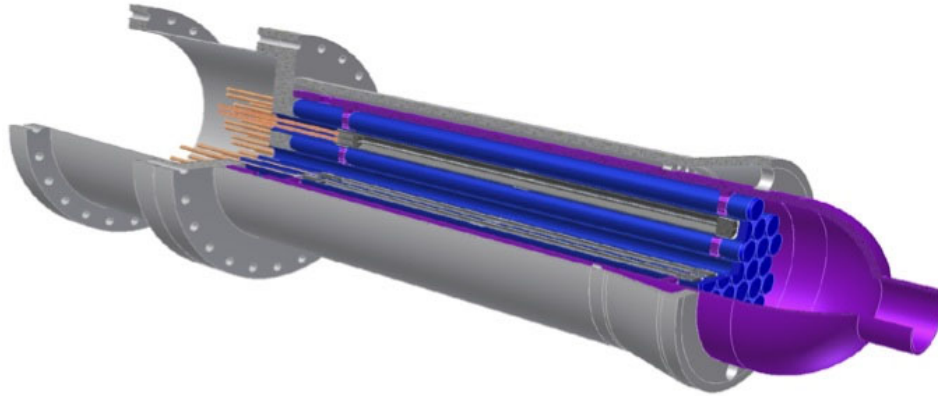

Figure 4.—The core simulator internal assembly showing the 36 pin-type heating elements.

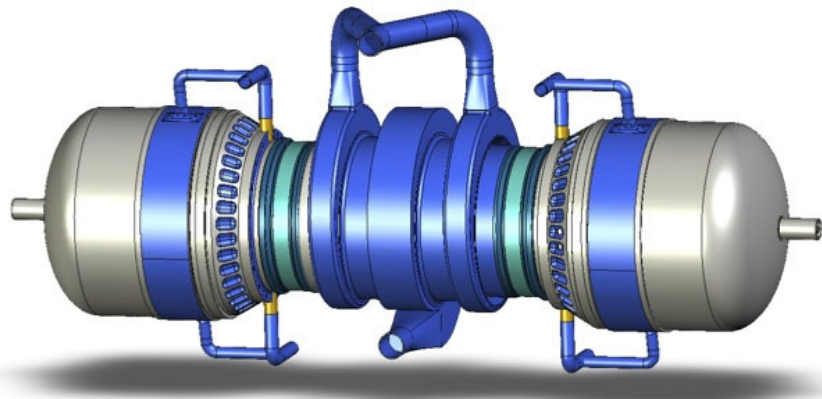

Figure 5.—The dual opposed Stirling PCU with central NaK heat exchanger manifold and water coolant lines.

vessel with NaK flow geometry and thermal capacitance that is based on the notional reactor core. The NaK is circulated through the core and delivered to the PCU by an annular linear induction pump (ALIP) developed by INL. The ALIP has no moving parts; it uses a series of magnetic coils to propel the electrically conductive fluid through a flow annulus. The ALIP power supply provides the means to vary flow rate by adjusting input frequency and voltage.

The 12-kWe PCU, shown in Figure 5, is a free-piston Stirling converter under development by Sunpower Incorporated with dual opposed engines that are thermodynamically coupled via a common helium expansion space (Ref. 15). The PCU uses gas bearings and planar springs to maintain non-contacting operation of the displacer and power piston within the cylinder housing. The converter is designed to operate at a temperature ratio of 2.2, frequency of 60 Hz, and a mean pressure of 6.2 MPa. At the hot end, the PCU has a stainless steel NaK heat exchanger that directs the flow axially through a radial gap across the heater head to heat the internal copper acceptor. The NaK heat exchanger uses a unique design approach where the primary helium pressure containment is outside of the NaK flow annulus. A small 1-mm stainless steel wall provides the fluid boundary between the NaK and the internal acceptor, thus minimizing the temperature drop. On the cold end, pumped water is routed through circumferential flow passages in the copper rejector to remove waste heat. A small fraction of the water flow is supplied to a cooling jacket that surrounds the alternator vessel for thermal management. The moving magnet linear alternator uses samarium-cobalt magnets in a titanium structure.

Checkout testing is expected to begin in 2011 with the Rx Sim primary loop verification test, including the core simulator, primary pump, and primary volume accumulator, with a gaseous nitrogen heat exchanger for heat removal. The two 6-kWe Stirling engines will be built and tested separately using electrically heated test heads, and then tested as a thermodynamically coupled pair before installing the

NaK heater head. Delivery of the completed Rx Sim and PCU is expected at GRC in mid-2012. The ensuing TDU test program will occur in two phases. During the first phase, the Rx Sim and PCU will be assembled in VF6 and the system will be tested under thermal-vacuum conditions with the external FCS providing PCU heat rejection. Phase 1 hardware checkout testing is scheduled to begin in late-2012. Also during the first phase, the HRS design and fabrication will be completed. After the phase 1 testing, the HRS will be integrated into the TDU test assembly. Phase 2 testing of the fully integrated system is scheduled for completion in late-2014, establishing system-level technology readiness of fission power for NASA exploration applications.

Preliminary Test Program

The TDU test program will be defined in detail at the Test Readiness Review prior to starting the initial test phase. The test program will consist of a number of test sequences, with each sequence having a specific test objective. A test sequence would produce a series of data points that address the test objective. The test system will be fully instrumented with temperature sensors (thermocouples and resistive temperature devices), pressure transducers, fluid flow meters, and electrical sensors (voltage, current, and frequency). Of particular interest is the ability to accurately determine the system energy balance based on heat delivered by the NaK loop, power generated by the Stirling converter, and heat removed by the water loop. A major goal for the testing is to demonstrate the functionality of the system over a wide range of operating conditions.

Testing would be conducted by varying available test parameters and collecting transient and steady-state data. There are a limited number of test parameters that can be varied as listed in Table 1. A pretest analytical simulation would be generated to guide the test sequence and assure that the system is operated within prescribed limits. Test sequences would be conducted on a 24 hr per day operation schedule and could last from several days to over a week in duration. At the conclusion of a test sequence, the system would be shut down and the test team would thoroughly review the data. The test data would be used to update the analytical model and provide improved accuracy for the next test sequence.

TABLE 1.—POTENTIAL TDU TEST VARIABLES

1. Core simulator power	<ul style="list-style-type: none"> a) <u>Constant power mode</u>—adjust the heater power supplies to achieve a set power output. b) <u>NaK exit temperature control mode</u>—adjust the heater power supplies to achieve a set NaK exit temperature. c) <u>Reactivity feedback control mode</u>—adjust the heater power supplies to respond to temperature changes based on reactivity feedback algorithms.
2. NaK flow rate	Adjust NaK pump power supply voltage and/or frequency.
3. Stirling piston amplitude	Adjust the alternator voltage through control of the terminal voltage and bidirectional energy (current) flow between the PCU controller and alternator.
4. Facility cooling system supply temperature	Adjust the amount of heat removed or added to the FCS water loop. (Note: this is not possible with the HRS.)
5. Water flow rate	Adjust water pump power supply voltage and/or current.
6. Radiator area	Use insulation to mask portions of the radiator surface prior to establishing vacuum.
7. Test environment	<ul style="list-style-type: none"> a) <u>Vacuum</u>—operate the facility at vacuum. b) <u>Thermal-vacuum</u>—operate the facility at vacuum and fill the cold walls with LN₂.

A preliminary test plan has been developed to guide the design process and identify operational expectations for the test hardware. The overall test philosophy is to start simple and introduce greater complexity as operations experience is gained. The preliminary test plan is summarized in Table 2. It starts with hardware installation and checkout to verify overall functionality and control. Initial hot testing would provide the proportional-integral-derivative (PID) coefficients to permit core simulator temperature control. Variable cold- and hot-end testing would be performed to evaluate performance sensitivity before proceeding into a full system map that would optimize system performance over a matrix of hot- and cold-end operating temperatures. With the performance mapped, the test system would be subjected to various heat-up profiles to optimize the startup sequence and various environmental transients to verify stable operation. The transient performance data will provide confidence to begin reactor feedback simulations that exercise the system over a range of operational perturbations while evaluating different feedback coefficients and component reactivity effects. With the system fully characterized and the control stability adequately evaluated, the test system would be subjected to a number of adverse transients that might be encountered during an actual mission including overheating, overcooling, loss of NaK flow, loss of water flow, PCU shutdown/restart, and extended cold soak. Before conducting these tests, the conditions will be carefully evaluated to assure that the system does not exceed its design limits and that no intentional damage occurs to the test hardware.

TABLE 2.—PRELIMINARY TEST PLAN

A1.	Rx-PCU Install and Checkout	All electrical connections, software, and instrument functionality will be verified. All fluid systems will be leak-checked and filled. All pumps and valves will be operated. The Core Sim will be heated to low temperature. The PCU will be cold motored.
A2.	Initial Hot Test	The system will be started at low power and gradually ramped to full temperature and power to gather general performance characteristics.
A3.	Core Sim Temp Control	The Core Sim will be operated in Temperature Control Mode and exercised over a range of conditions to verify stable operation.
A4.	Variable Cold End	The FCS and water loop will be exercised over a range of conditions with a fixed hot end to evaluate system performance sensitivity.
A5.	Variable Hot End	The Core Sim and NaK loop will be exercised over a range of conditions with a fixed cold end to evaluate system performance sensitivity.
A6.	System Performance Map	The system will be exercised over a matrix of hot- and cold-end temperatures. The PCU will be tuned by varying piston amplitude to optimize performance at each setting to create a system performance map.
A7.	Lunar Environments	The system will be subjected to various startup scenarios to determine minimum start time and minimum start energy. The system will be subjected to a simulated lunar/night cycle to verify stable operation.
A8.	Reactor Feedback Simulation	The Core Sim will be operated in Reactor Feedback Mode and exercised over a range of conditions to verify stable operation. The reactivity feedback coefficients will be varied to evaluate system response characteristics.
A9.	Transients and Faults	The system will be subjected to a series of adverse transients (e.g., reactor over-temp, loss of NaK flow, radiator over-temp, loss of water flow, PCU shutdown, hot restart, and electrical load faults) in a controlled manner to evaluate system response characteristics.
A10.	Cold Soak Start	The system will be subjected to an extended thermal cold soak and started to evaluate system response characteristics.
B1.	HRS Install and Checkout	All electrical connections, software, and instrument functionality will be verified. All fluid systems will be leak checked and filled. All pumps and valves will be operated. The HRS will be partially heated.
BX.	Repeat Rx-PCU Tests With HRS	B2. Initial Hot Test B3. Core Sim Temperature Control B4. Variable Cold End B5. Variable Hot End B6. System Performance Map B7. Lunar Environments B8. Reactor Feedback Simulation B9. Transients and Faults B10. Cold Soak Start

This same basic test plan will be repeated following HRS installation and checkout. The majority of this test phase will be conducted with the LN₂ coldwalls filled to provide the thermal environment for the HRS radiators. The system performance and dynamic behavior will be considerably different with the HRS due to the fixed heat rejection capacity of the radiators as compared to the FCS. The integrated system testing with the HRS will provide a more realistic indication of operating performance, similar to what would be expected during actual space operations.

Conclusions

The Fission Power System project has adapted to program and agency-level changes and is on track to demonstrate the technology readiness of fission power systems for space applications. The NASA and DOE team have completed concept development studies and “pathfinder” component tests that have positioned the project to conduct a full-scale, non-nuclear integrated system test. The team will assemble an electrically heated reactor core simulator, NaK heat transport loop, Stirling power conversion unit, and radiator heat rejection system into a FPS Technology Demonstration Unit that will be operated in a thermal-vacuum environment to demonstrate system-level performance. The basic test plan will subject the system to realistic operating conditions and gather data to evaluate system performance sensitivity, control stability, and response characteristics. The testing is scheduled to begin in late-2012 and continue through 2014, at which time the requirements for Technology Readiness Level 6 should be achieved allowing FPS to transition into flight development if needed to support future NASA missions.

References

1. Palac, D.T., Mason, L.S., Houts, M.G., and Harlow, S., “Fission Surface Power Technology Development Status,” NASA/TM—2010-216249, April 2010.
2. Palac, D.T., Mason, L.S., Houts, M.G., and Harlow, S., “Fission Surface Power Technology Development Update,” AIAA-2010-8711, *AIAA SPACE 2010 Conference and Exposition*, Anaheim, California, 30 Aug.–2 Sept. 2010.
3. *Affordable Fission Surface Power System Study Final Report*, Exploration Systems Mission Directorate Memorandum for the Record, 5 October 2007.
4. *Executive Summary of Reference Fission Surface Power System Concept Selection*, Exploration Systems Mission Directorate Memorandum for the Record, 23 July 2008.
5. Mason, L., Poston, D., and Qualls, L., “System Concepts for Affordable Fission Surface Power,” NASA/TM—2008-215166, January 2008.
6. Fission Surface Power Team, “Fission Surface Power System Initial Concept Definition,” NASA/TM—2010-216772, August 2010.
7. Mason, L.S., and Poston, D.I., “A Summary of NASA Architecture Studies Utilizing Fission Surface Power Technology,” *Proceedings of the 8th International Energy Conversion Engineering Conference*, AIAA-2010-6599, Nashville, Tennessee, 25-28 July 2010.
8. Mason, L., “Recent Advances in Power Conversion and Heat Rejection Technology for Fission Surface Power,” NASA/TM—2010-216761, July 2010.
9. Ellis, D., and Mason, L.S., “Performance Testing Of A Full-Scale Radiator for Fission Surface Power Applications,” *Proceedings of the 8th International Energy Conversion Engineering Conference*, AIAA-2010-6760, Nashville, Tennessee, 25-28 July 2010.
10. Polzin, K.A., Pearson, J.B., Schoenfeld, M.P., Webster, K., Houts, M.G., Godfroy, T.J., and Bossard, J.A., “Performance Testing of a Prototypic Annular Linear Induction Pump for Fission Surface Power,” NASA/TP—2010-216430, May 2010.
11. Birchenough, A.G., Hervol, D.S., and Gardner, B.G., “Test Results From a High Power Linear Alternator Test Rig,” NASA/TM—2010-216910, November 2010.

12. Briggs, M.H., Geng, S.M., Pearson, J.B., and Godfroy, T.J., "Summary of Test Results From a 1 kWe-Class Free-Piston Stirling Power Converter Integrated With a Pumped NaK Loop," NASA/TM—2010-216934, December 2010.
13. Fuller, R.L., "Closed Brayton Cycle Power Conversion Unit for Fission Surface Power, Phase I Final Report," NASA/CR—2010-215673, June 2010.
14. Wood, G.J., Buffalino, A., Holliday, E., Penswick, B., and Gedeon, D., "Free-Piston Stirling Power Conversion Unit for Fission Surface Power, Phase I Final Report," NASA/CR—2010-216750, July 2010.
15. Wood, G.J., Holliday, E., Cale, T., and Stanley, J., "The Design and Development of a 12 kWe Stirling Power Conversion Unit for Fission Power Technology Demonstration," *Proceedings of Nuclear and Emerging Technologies for Space, NETS-2011*, Paper 3488, Albuquerque, New Mexico, 7-10 February 2011.

REPORT DOCUMENTATION PAGE			Form Approved OMB No. 0704-0188		
<p>The public reporting burden for this collection of information is estimated to average 1 hour per response, including the time for reviewing instructions, searching existing data sources, gathering and maintaining the data needed, and completing and reviewing the collection of information. Send comments regarding this burden estimate or any other aspect of this collection of information, including suggestions for reducing this burden, to Department of Defense, Washington Headquarters Services, Directorate for Information Operations and Reports (0704-0188), 1215 Jefferson Davis Highway, Suite 1204, Arlington, VA 22202-4302. Respondents should be aware that notwithstanding any other provision of law, no person shall be subject to any penalty for failing to comply with a collection of information if it does not display a currently valid OMB control number.</p> <p>PLEASE DO NOT RETURN YOUR FORM TO THE ABOVE ADDRESS.</p>					
1. REPORT DATE (DD-MM-YYYY) 01-12-2011		2. REPORT TYPE Technical Memorandum		3. DATES COVERED (From - To)	
4. TITLE AND SUBTITLE Design and Test Plans for a Non-Nuclear Fission Power System Technology Demonstration Unit			5a. CONTRACT NUMBER		
			5b. GRANT NUMBER		
			5c. PROGRAM ELEMENT NUMBER		
6. AUTHOR(S) Mason, Lee; Palac, Donald ; Gibson, Marc; Houts, Michael; Warren, John; Werner, Jim; Poston, David; Qualls, Arthur, Lou; Radel, Ross; Harlow, Scott			5d. PROJECT NUMBER		
			5e. TASK NUMBER		
			5f. WORK UNIT NUMBER WBS 429698.01.03		
7. PERFORMING ORGANIZATION NAME(S) AND ADDRESS(ES) National Aeronautics and Space Administration John H. Glenn Research Center at Lewis Field Cleveland, Ohio 44135-3191			8. PERFORMING ORGANIZATION REPORT NUMBER E-17608		
9. SPONSORING/MONITORING AGENCY NAME(S) AND ADDRESS(ES) National Aeronautics and Space Administration Washington, DC 20546-0001			10. SPONSORING/MONITOR'S ACRONYM(S) NASA		
			11. SPONSORING/MONITORING REPORT NUMBER NASA/TM-2011-217100		
12. DISTRIBUTION/AVAILABILITY STATEMENT Unclassified-Unlimited Subject Category: 20 Available electronically at http://www.sti.nasa.gov This publication is available from the NASA Center for AeroSpace Information, 443-757-5802					
13. SUPPLEMENTARY NOTES					
14. ABSTRACT A joint National Aeronautics and Space Administration (NASA) and Department of Energy (DOE) team is developing concepts and technologies for affordable nuclear Fission Power Systems (FPSs) to support future exploration missions. A key deliverable is the Technology Demonstration Unit (TDU). The TDU will assemble the major elements of a notional FPS with a non-nuclear reactor simulator (Rx Sim) and demonstrate system-level performance in thermal vacuum. The Rx Sim includes an electrical resistance heat source and a liquid metal heat transport loop that simulates the reactor thermal interface and expected dynamic response. A power conversion unit (PCU) generates electric power utilizing the liquid metal heat source and rejects waste heat to a heat rejection system (HRS). The HRS includes a pumped water heat removal loop coupled to radiator panels suspended in the thermal-vacuum facility. The basic test plan is to subject the system to realistic operating conditions and gather data to evaluate performance sensitivity, control stability, and response characteristics. Upon completion of the testing, the technology is expected to satisfy the requirements for Technology Readiness Level 6 (System Demonstration in an Operational and Relevant Environment) based on the use of high-fidelity hardware and prototypic software tested under realistic conditions and correlated with analytical predictions.					
15. SUBJECT TERMS Space power; Fission power systems; Space reactor; Free-piston Stirling					
16. SECURITY CLASSIFICATION OF:			17. LIMITATION OF ABSTRACT	18. NUMBER OF PAGES	19a. NAME OF RESPONSIBLE PERSON
a. REPORT	b. ABSTRACT	c. THIS PAGE			STI Help Desk (email:help@sti.nasa.gov)
U	U	U	UU	17	19b. TELEPHONE NUMBER (include area code) 443-757-5802

