

# Environmental Control and Life Support System Design for a Space Exploration Vehicle

Imelda Stambaugh<sup>1</sup> and Branelle Rodriguez<sup>2</sup>  
*NASA Johnson Space Center, Houston, Texas, 77058*

Walt Vonau, Jr.<sup>3</sup>  
*Jacobs Technology, Houston, Texas, 77058*

and

Melissa Borrego<sup>4</sup>  
*MEI Technologies, Houston, Texas, 77058*

Engineers at Johnson Space Center are developing an Environmental Control and Life Support System (ECLSS) design for the Space Exploration Vehicle (SEV). The SEV will aid in expanding the human exploration envelope for geostationary transfer orbit, near-Earth orbit, or planetary missions by using pressurized surface exploration vehicles. The SEV, formerly known as the Lunar Electric Rover, will be an evolutionary design starting as a ground test prototype where technologies for various systems will be tested and will evolve into a flight vehicle. This paper will discuss the current SEV ECLSS design, any work contributed toward the development of the ECLSS design, and the plan to advance the ECLSS design based on the SEV vehicle and system needs.

## Nomenclature

<i>cfm</i>	=	cubic feet per minute
<i>lpm</i>	=	liters per minute
<i>CO<sub>2</sub></i>	=	carbon dioxide
<i>kg</i>	=	kilogram
<i>L</i>	=	liter
<i>O<sub>2</sub></i>	=	oxygen
<i>psi</i>	=	pounds per square inch

---

<sup>1</sup> SEV ECLSS Lead, NASA Johnson Space Center, Crew and Thermal Systems Division, EC2, not AIAA affiliated

<sup>2</sup> WCS and Trash Project Lead, NASA Johnson Space Center, Crew and Thermal Systems Division, EC3, not AIAA affiliated

<sup>3</sup> Thermal and Life Support Analyst, 2224 Bay Area Blvd, Houston, TX 77058, not AIAA affiliated

<sup>4</sup> Project Engineer, 2525 Bay Area Blvd, #300, Houston, TX 77058, not AIAA affiliated

## I. Introduction

The Space Exploration Vehicle (SEV) is a pressurized, gravity-dependent vehicle to be used for planetary or moon-based exploration. The SEV project is building ground test vehicles that will evolve into a flight design. Initially, a rudimentary fluid schematic was developed during the Constellation (CxP) Lunar Surface Systems Program for a surface rover's flight Environmental Control and Life Support System (ECLSS). This schematic was implemented and improved upon for use as the basis for the Lunar Electric Rover, later named the SEV. Engineers made changes to the schematic, which resulted from integration discussions with other systems supported by ECLSS. This schematic can be seen in Fig. 1.<sup>1</sup> The SEV ECLSS consumables and hardware support a crew of 2 nominally for 7 days and a crew of 4 off nominally for 72 hours. Contingencies considered during these iterative design cycles are feed the leak and depress/repress cycle of the cabin atmosphere in case of fire, and a rescue a crew of 2 with a 72 hour transit to the base/lander.

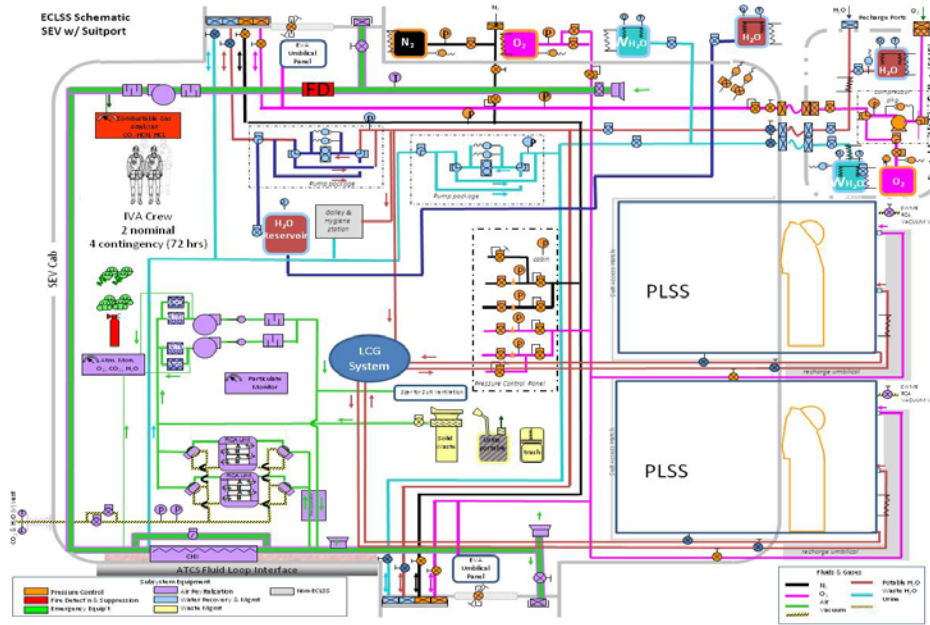

Figure 1: SEV ECLSS Schematic<sup>1</sup>

## II. System Description

The schematic referenced in Fig. 1 highlights four systems essential for life support: the Air Revitalization System (ARS), the Pressure Control System (PCS); the Potable Water System (PWS); and the Waste Control System (WCS). The ARS provides cabin air circulation and thermal control, trace contaminant control, carbon dioxide (CO<sub>2</sub>) scrubbing, moisture recuperation, and atmospheric monitoring. The PCS regulates the cabin total pressure and constituent partial pressures. The PWS dispenses both hot and cool potable water for drink preparation, meal preparation, and hygiene. It also stores hygiene and condensate waste water. The WCS collects and stores human metabolic waste, and food and packaging waste.

## III. Research, Trades, and Analysis

### A. Portable Life Support System Commonality with Environmental Control and Life Support System Air Revitalization System

Engineers performed an analysis in 2009 to determine whether there were any opportunities to leverage technology between the Portable Life Support System (PLSS) for the suit and the ECLSS in the Lunar Rover, known the following year as the SEV. The five categories identified as possible candidates for commonality were: CO<sub>2</sub> removal; atmosphere composition monitoring – CO<sub>2</sub> sensors; pressure control – CO<sub>2</sub> regulators; cabin pressure

monitor – redundancy; and the rover’s ability to filter the air through its Trace Contaminant Control System to protect the PLSS.

The study was performed on a delta mass basis to the baseline architecture with data for the SEV’s ECLSS based on information presented at a schematic review presentation on April 9, 2009. The baseline mass of 150.6 kg (322 lbs) was determined from numbers on both the ARS (103.3 kg (227.7 lbs)) and the PCS (46.7 kg (103 lbs) i). These masses were determined from a Master Equipment List (MEL) exercise conducted by the project. Some mass estimations were based on comparisons with ORION hardware mass data and others with ground hardware mass data. The delta mass analysis would be based on the parts of the ECLSS that would no longer be needed and their masses would be removed from the baseline totals (resulting in a negative delta). The baseline also assumed that there would be three full PLSS units on the SEV (two in-service and one spare) as part of a full equipment complement for the rover and, therefore, any of the possible life support designs for the rover could use up to three PLSS units at no mass penalty. However, use of a fourth or more PLSS units would be added to the delta mass (resulting in a positive delta). The baseline masses also do not take into account fluid line masses for either baseline equipment or hardware added for a specific life support design. Masses for fluid lines were unknown as were line lengths between components. Therefore, future reviews of these designs with line lengths included could see swings in the delta mass numbers.

The five cases that were analyzed are shown below in Table 1. For each case, the table shows how many PLSS units would be onboard the SEV, the pressure that could be used to maintain the thermal conditioning in the suit, and the responsibility for the ECLSS Rapid Cycling Amine (RCA), oxygen (O<sub>2</sub>) regulators and CO<sub>2</sub> sensors would reside. S1 in the table is the first spare PLSS; 1 and 2 are the in-service PLSS on the SEV.

**Table 1. SEV/PLSS Commonality Trade Space**

Case	Total # of PLSS units onboard	Thermal Maintenance Approach	ECLSS RCA Function	O <sub>2</sub> Regulator Function	CO <sub>2</sub> Sensors
Baseline	3	0.9 or 8.0 psi	SEV	SEV	SEV
Common – 1 Spare/1 In-service	3	8.0 psi	S1, 1	S1, 1	S1, 1
Common Design (Unique Hardware)	3	0.9 or 8.0 psi	SEV	SEV	SEV
Suit Thermal Conditioning Air	3	8.0 psi	1, 2	1, 2	1, 2
Common Hardware/Contingency/Water Suit Thermal Management	3	0.9 psi	SEV	SEV	SEV

The baseline case was the entire ARS and PCS systems being built in to the vehicle to make up the ECLSS. Whereas similar technologies may be used (like the RCA beds), the SEV’s ECLSS was base lined in the schematics with the mass estimates from the vehicle MEL exercise, and a mass savings comparison was made between this baseline case the other four cases .The second case uses an in-service PLSS as well as the spare PLSS. Use of the PLSS for SEV ECLSS, allows for the vehicle ECLSS RCA, fan and muffler to be removed from the mass of the ARS system. In addition, both of the O<sub>2</sub> regulators would be removed from the PCS control panel vehicle mass. The drawbacks to the design are that the PLSS fans would be running longer than the current specs outline. The current PLSS fan is rated for 2,500 hours, which is more than 300 8-hour extravehicular activities (EVAs). For the vehicle ECLSS, the unit would be expected 24 hours a day 7 days a week and could be on nominally for if the space is used a living quarters in a habitat. It would be expected that that the fan life would would be depleted in about 15 weeks. Habitat missions are expected to last for longer than 15 weeks. The suits would have to be maintained at 8.0 psi because the suits are part of the cabin pressurized volume. Low-pressure air connections would be made in the opposite direction from the baseline because now the air has to flow through the entire suit/PLSS package rather than just through the suit volume which ignores the backpack in the baseline configuration. Contingencies may also be an issue since this case uses one of the in-service PLSS’s for nominal cabin operations. The PLSS relief valves would have been used vent the cabin in the event of a fire while crew is on EVA or the PLSS would have to have been reconfigured for use in the suit since the suit is the safe haven in the event of the loss of cabin pressure control.

The third case uses the same layout as the baseline plan but uses the lightest components available between the SEV ECLSS design and the PLSS design. The major changes would be the PLSS RCA unit being used in the vehicle, which saves 16.4 kg (36.2 lbs), as well as, the PLSS PCS valves and sensors, which saves 9.4 kg (20.7 lbs).

The fourth case removes the RCA and both fans and the muffler from the SEV ECLSS, and uses both in-service PLSS units in buddy mode. By keeping both PLSS units in buddy mode, enough air flow is expected to be provided to thermally maintain the suits and provide scrubbed air to the rover cabin. The issues with this plan are that the low-pressure connections are reversed from the baseline (for the same reason as the second case), the PLSS fans are not optimized for operation in buddy mode for the extended times required by this design, and a proportional split would have to be installed to divide the flow between that going into the helmet for thermal maintenance of the suit and that returning to the cabin volume. Contingency cabin repress from vacuum may also be an issue just as it was with case 2 since the PLSS would be needed for contingency cabin operations and need to be reconfigured for loss of cabin pressure control so the crew could use their suits as a safe haven. The fifth and final design is the PLSS common design/Contingency/Water Suit Thermal Management. The changes for this design are that the baseline ARS design is maintained but the lighter PLSS RCA unit is used. One O<sub>2</sub> regulator is removed from the PCS control panel. The spare PLSS can be plugged in as well, which allows for its use in redundant, contingent, or emergency operations. The low-pressure lines would need to be reversed again if the PLSS on the suits are needed to perform CO<sub>2</sub> removal (for the same reason as the second case).

The final mass savings are shown in Table 2. The fourth and fifth cases are expected to require more power than the baseline case due to anticipated increased demands placed on the fans. No hard plumbing issues need to be overcome beyond the ability to flip the low-pressure lines in the umbilical. The operational constraints are a little higher for the second and fourth case because these constraints rely on tying in the PLSS units that are still attached to the suits. The delta masses do not include any savings for secondary structure, interconnects or other things of that nature. The delta masses are strictly based on the change in mass from swapping parts.

**Table 2. Rover/PLSS Commonality Trade Delta Mass Results**

Baseline	1 Spare / 1 In-service	Common Design	Suit Thermal Conditioning – Air	Common Hardware/Contingency/Water Suit Thermal Management
0 kg	-37 kg	-26.3 kg	-38.3 kg	-29.9 kg

Other concept issues discussed during the study included the fact that the PLSS currently does not have its own pressure relief system. It relies on being connected to the suit for pressure relief. If a fully charged spare PLSS is stored on the rover, it would dump to the cabin of the rover. Contingencies may introduce some difficulties with several of the designs presented as the PLSS hardware is not necessarily required to perform at the same level as the repress system if the PLSS hardware is going to replace the repress system. Further work on the rover is needed to determine what issues may in fact be present.

## **B. Common Portable Life Support System Fan for the Air Revitalization System**

A previous study, conducted in fiscal year 2009, looked at the feasibility of parts/units compatibility between the SEV and the PLSS. One of the ideas forwarded from that effort was to determine the fan power that would actually be needed for some of the suggested designs.

The first task was to establish the current baseline pressure drop for the SEV. The major pressure drop components identified from the system were the ARS ducting, water recuperator, RCA unit, trace contaminant system, muffler, suit umbilical, and the suit itself. It is worth noting that the current baseline does not include the use of cabin air being sent to the suit; however, determining the suit values is necessary to scar for the umbilicals, if such a move is desired in the future.

Table 3 shows the initial pressure drop data for the baseline case. The suit and umbilical data were based on a previous analysis performed in-house for the Crew Exploration Vehicle umbilical model. The trace contaminant control system and ARS muffler pressure drop was from the Orion design 606 H data.<sup>2</sup> The RCA unit data came from the PLSS data provided by the PLSS team, and the ducting was calculated based on a rough estimate. The

recuperator was originally based on a system being developed in conjunction with NASA Ames Research Center using Nafion tubes to chemically move water vapor through the walls.

**Table 3. Pressure Drop Values for SEV Baseline Case**

Part	Pressure Drop (Pa)	Pressure Drop (in H <sub>2</sub> O)
ARS Ducting	4.3	0.0173
Recuperator (Nafion)	4000	16.07
PLSS RCA unit	1045	4.2
Trace Contaminant Control System	133	0.535
ARS Muffler	28	0.113
Suit Umbilical	2528	10.16
Suit	1508	6.06
Total	9246.3	37.16

The table shows an extremely high pressure drop for the ECLSS loop. Instead of examining the other cases from the previous study effort, the team decided to see if a lower baseline pressure drop could be developed by looking at alternative recuperation methods and ARS loop configurations. The first change was to remove the suit umbilical and suit pass-through from the loop. Whereas it may be possible to implement a design that has its own port into the PLSS pack and directly interfaces with the unit without flowing through the suit and umbilical, that concept goes beyond the scope of this study. Removing the suit umbilical and suit pass-through from the loop reduces the overall total pressure drop from 9246.3 Pa (37.16 in H<sub>2</sub>O) to 5015.9 Pa (20.94 in H<sub>2</sub>O). Of 5015.9 Pa (20.94 in H<sub>2</sub>O), about 80% of it comes from the recuperator. The focus became to find a way to improve the pressure drop of the recuperator and to look for fans that might be able to handle the pressure drop of the loop once any improvements were made to the recuperator value.

*1. Recuperator*

The design used by NASA Ames Research Center consisted of Nafion tubes. The unit acts in a counter-flow shell-and-tube design where the moist air enters tubes from one end and the dry, CO<sub>2</sub>-free air enters the shell side from the other end.<sup>3</sup> A basic fluid flow path can be seen in Fig. 2.4

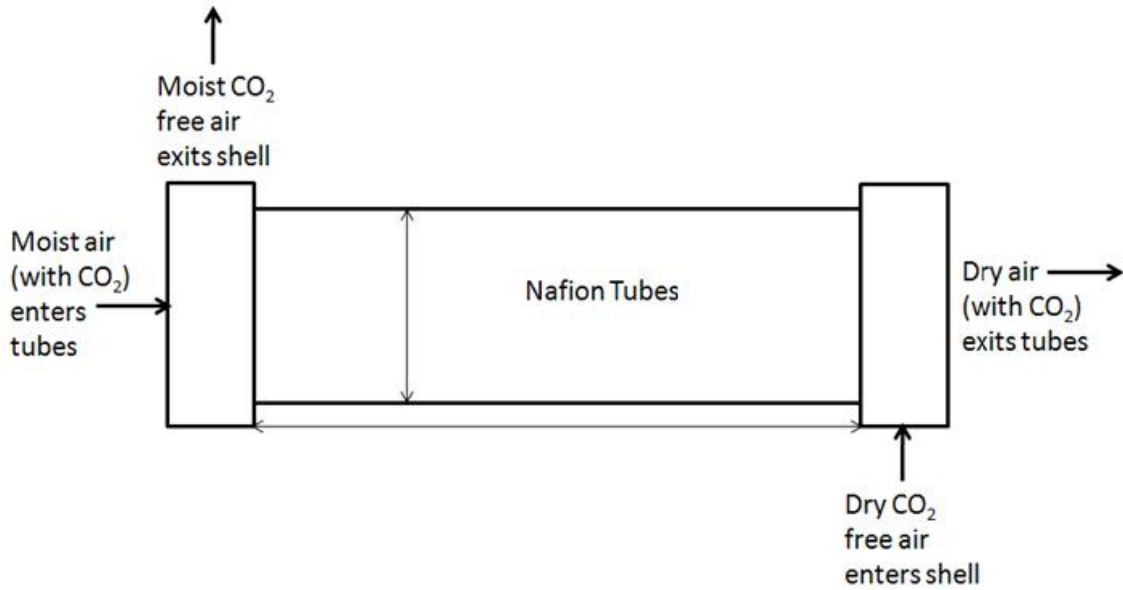

**Figure 2. Nafion recuperator flow schematic.**

Ideally, the pressure drop for a system like this could be reduced by using more of a pancake-style design (bigger diameter, shorter tube length). However, the pressure drop values quoted in their presentations could not be duplicated by analytical means. The research team that performed testing with this unit indicated that the large pressure drop was what they saw. They also indicated that they would not use the recuperator again as designed; therefore, pursuing this design did not seem a wise idea.

Another suggested recuperator design had a lower inherent pressure drop. This recuperator is based on zeolite substrate, and is being researched at Marshall Space Flight Center. This design does not require heaters for the main beds, as the beds are thermally linked between the adsorbing and desorbing sides, resulting in an isothermal bulk desiccant (IBD). Testing has been done at 140 L/min (5 cfm) air flow with a 10°C (50°F) inlet dew point. With 2-minute half-cycle times, the unit was able to achieve 90% water removal efficiency (down to -17°C (0°F) outlet dew point from IBD) with only 747.3 Pa (3 in H<sub>2</sub>O) pressure drop. Figure 3 shows a process diagram for this recuperator.<sup>5</sup> Residual dryers are used to remove the remaining water vapor from the air, which requires heating to regenerate. With this change, the new total pressure drop for the components in just the cabin loop is 1960.3 Pa (7.87 in H<sub>2</sub>O). This is a more manageable pressure drop that the fan search focused on meeting.

**2. Fan Search**

The fan to be used to flow through capable of overcoming the pressure drop life as it will be in constant use. The

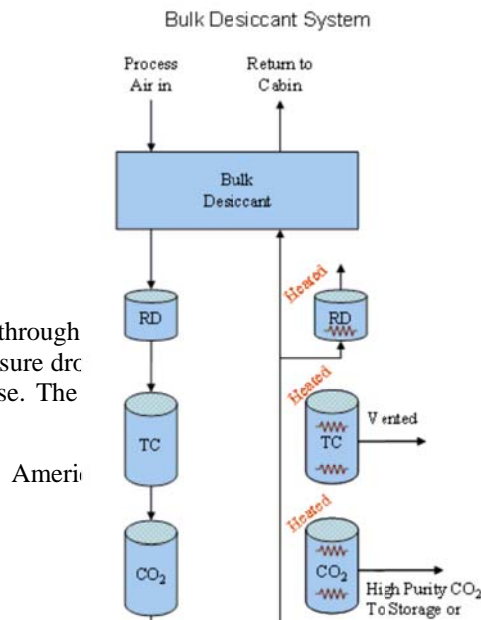

to meet the flow rate needed, and beds selected needs to have substantial 2 cfm at 70 °F and 1 atm based on

utics

previous modeling of the PLSS RCA units to meet the CO<sub>2</sub> scrubbing requirements. The fan can handle a pressure drop of at least 8 in H<sub>2</sub>O.

The current suit fan was the first fan examined. At the design point for the fan, it is less than half the flow rate, 707.9 lpm (25 cfm) desired and about one-third of the pressure drop needed with the suit and umbilical volumes added to the system, 6000 Pa (24.09 in H<sub>2</sub>O) . Even with two fans in parallel, the pressure drop needed would be near the upper limit of what the fan would be capable of producing. The fan's useful life is also currently rated for only 2,500 hours, minimum. This could seriously hamper the use of the fan if it will last for only 3 months. A typical ECLSS fan would be circulating 24 hours a day. Furthermore, even if several of the fans could be implemented to meet the required pressure drops and flowrates and spares could be flown for failure rates, this would fan would not even be capable meeting circulation needs in the cabin which could be above 4247.5 lpm (150 cfm) based on a comparison with data from ORION. Thus, a second fan would be needed to meet the cabin circulation requirements.

The team performed a search to determine whether other commercial off-the-shelf fans meet the needs for the ARS system. Nine fans met the basic criteria. Most all of the fans showed a minimum of 20,000 hours for mean time to failure. Any of these blowers should be able to meet the flow rate and pressure drop requirements for the system. Other factors such as size, mass, power, and noise produced will likely be the deciding factors for picking a blower.

### C. Cascade Tank Analysis

SEV ECLSS is required to service the EVA high-pressure O<sub>2</sub> tanks in the PLSS. Initial studies showed a single O<sub>2</sub> tank would have excess ullage to support the EVA on SEV missions. A study was kicked off to determine whether cascading the O<sub>2</sub> tanks would minimize the mass and volume of O<sub>2</sub> and tanks needed. A cascade system provides a series of tanks at high pressure that are used in sequence to fill a high pressure reservoir or tank when needed. Scheduling the use of the O<sub>2</sub> tanks ensures that there is enough O<sub>2</sub> at a high enough pressure to service the EVA PLSS tank for the number of EVAs to be performed in the mission. Once the high pressure O<sub>2</sub> is used in one tank, the next tank can be used for EVA high pressure O<sub>2</sub> recharge. The lower pressure O<sub>2</sub> can be used to support metabolic and cabin pressure control needs. For SEV, high-pressure and low-pressure O<sub>2</sub> is required to support EVA and maintain the cabin atmosphere, respectively. A cascade system of tanks was compared to using a single tank system to hold all the missions O<sub>2</sub>, a two-tank system (one that serves IVA operations and one that serves EVA operations), and a two-tank and compressor system. All tanks in this study start at a maximum pressure of 3600 psi. This study looked at a mission of 3-, 7-, 14-, and 28-day missions. It was assumed that the cascade tanks had a starting pressure of 3600 psi and the PLSS tanks were filled to 3000 psi. It was assumed that each PLSS tank is sized for and was initially serviced for 8 hours of EVA. Each day, a maximum of four cycles were performed on the suit port per crew member per day for a maximum total of 4 hours of EVA. IVA, EVA, cabin leakage, CO<sub>2</sub> reduction hardware losses, and contingency gas were accounted for in the sizing of the tanks. On top of the consumables, the mass for support hardware and plumbing was included to conduct a mass comparison.<sup>4</sup>

Fig. 4 presents the results for the tank cascade for 3, 7, 14, and 28 day missions. Each plot displays when the total tank mass (gas, valves and tank shell) begins to increase as the number of tanks are added to the cascade system or shows diminishing returns by increasing the number of tanks. All tanks start at 3600 psi and are equal sizes. Each EVA tank is filled to 3000 psi. The tank minimum tank pressure is set at 150 psi. A goal seek method was used to determine the mass in the O<sub>2</sub> tanks to meet the IVA, and EVA constraints. For a cascade system to support high-pressure O<sub>2</sub> for EVAs, 3-, 7-, 14-, and 28-day missions would require 2, 3, 4 and 7 tanks, respectively, as seen in Fig. 4<sup>6</sup>.

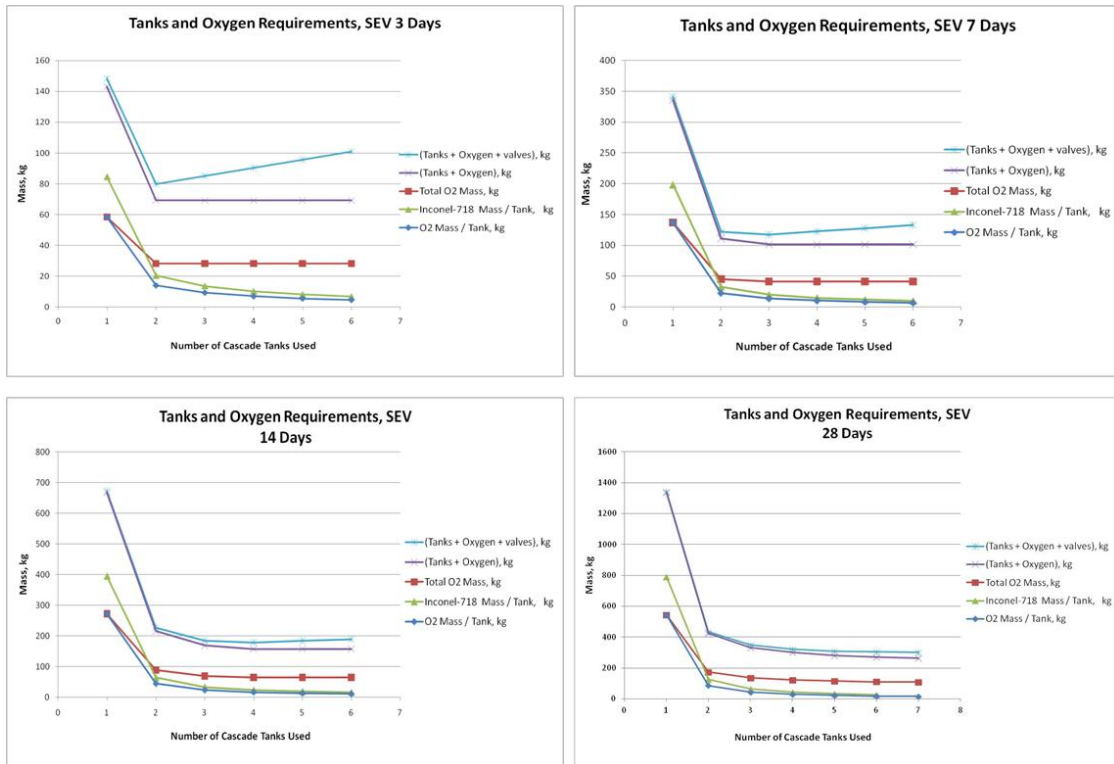

Figure 4: Results from Cascade Analysis for 3, 7, 14, and 28 days<sup>6</sup>.

The team also conducted an analysis to determine whether varying tank size for two to three tank configurations would make a difference. The results showed only about 1% of the launch mass could be saved if the tank size was varied in a half kg ramp rate from -0.5 kg to +2.0 kg.

This study compared the single tank, cascade system, and single IVA and EVA tank. As the mission duration increased from 3 to 28 days, the mass for the cascade system was lower than the single tank and the two-tank (IVA/EVA) system.

The cascade system was compared to two tanks and a compressor to support the high-pressure O<sub>2</sub> service of the PLSS tank. The tank mass was the same for both options since the starting pressure for all the tanks in both options is 3600 psi and the tank mass is proportional to the initial pressure and the O<sub>2</sub> mass. For all mission durations except a 28 day mission, minimal mass savings was found in the number of accessories needed for the cascade system versus the number of accessories plus the compressor mass needed for the two-tank/compressor configuration. The data can be seen in Fig 5. As the mission duration exceeded 14 days, the number of tanks for the cascade system increased and the tank and support hardware mass minimally increased. For the 28 day mission, the difference in mass between the compressor/two-tank system and the cascade system is about 5.4 kg, where the cascade system is slightly heavier than the compressor two-tank system.<sup>6</sup>



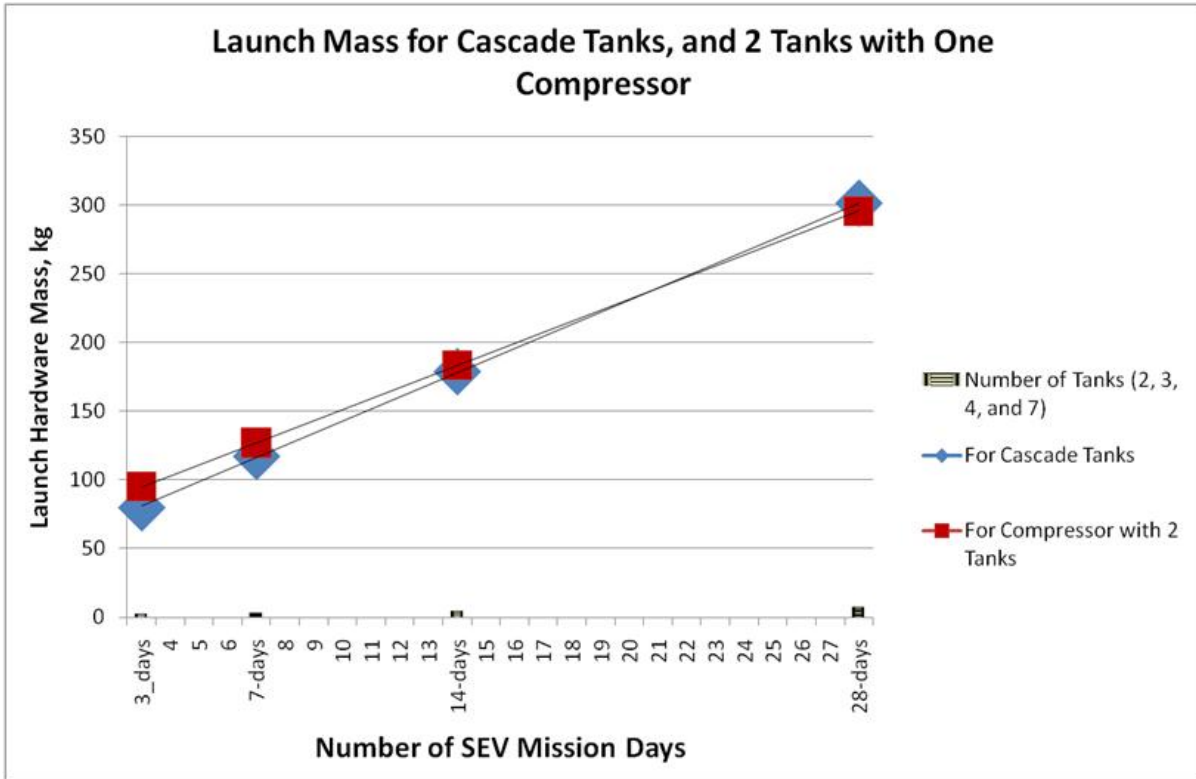

Figure 5: Launch Mass for Cascade Tanks and 2 Tanks with One Compressor<sup>6</sup>

#### IV. Hardware Development for GEN II A

##### A. Potable Water System

###### 1. General Functional Description

The SEV's two crew members will require potable water for drinking, hygiene, and meal rehydration. The task was to develop a potable water system (PWS) to be used in a ground test, designed to fill the volume allotted by the vehicle design, and have the flexibility for an upgrade to a flight system. The PWS provides hot and ambient drinking water for the crew. The hot water is used to rehydrate meals. The tank was sized to contain up to 3 days of water.<sup>7</sup>

###### 2. Potable Water System Subsystems

The PWS consists of five major subsystems, core, dispenser, storage, ground support, and power distribution. The core subsystem contains the pump, pressure controls, relieve valves, heaters, scar for the chiller, filtration, tubing, and leak detection. The dispenser is physically connected to the core system. It consists of the controls and interface hardware for dispensing and a drain. The drain is needed in the event of a system overflow or the crew's need to discard fluid. The storage subsystem contains a tank with level monitoring instrumentation. The monitoring instrumentation provides the ground support team insight in the tank level. The ground support subsystem consists of a panel to support and monitor the recharge of the PWS tank. This allows for the tank to be serviced external to the vehicle without interfering with the ground test. The power distribution subsystem contains the power bus, conversion relays, fuses, and breakers. This allows for the safe distribution of power from the main vehicle bus to the electrically powered hardware in the PWS.<sup>7</sup>

###### 3. Potable Water System Operation

The PWS has a dispense location in the vehicle (Fig. 6). At this location, the crew can actuate the controls necessary for dispensing ambient and hot water. At the panel, the crew can control the PWS master power, enable the pump circuit, turn on the heater, and operate the two-way hot vs. cold water dispense valve. The purge and drain system valve controls are locked out and utilized in for contingency or ground-support scenarios. The panel also

indicates when the hot water has reached the maximum temperature for dispense. Placeholder spaces for the PWS “cool” water upgrade are also available. This feature will be added to the next generation PWS design. In addition, a light-emitting diode indicator will indicate and annunciate a leak in the water basin. All switches on the panel are labeled and have bump guards to prevent unintended actuation.<sup>57</sup>

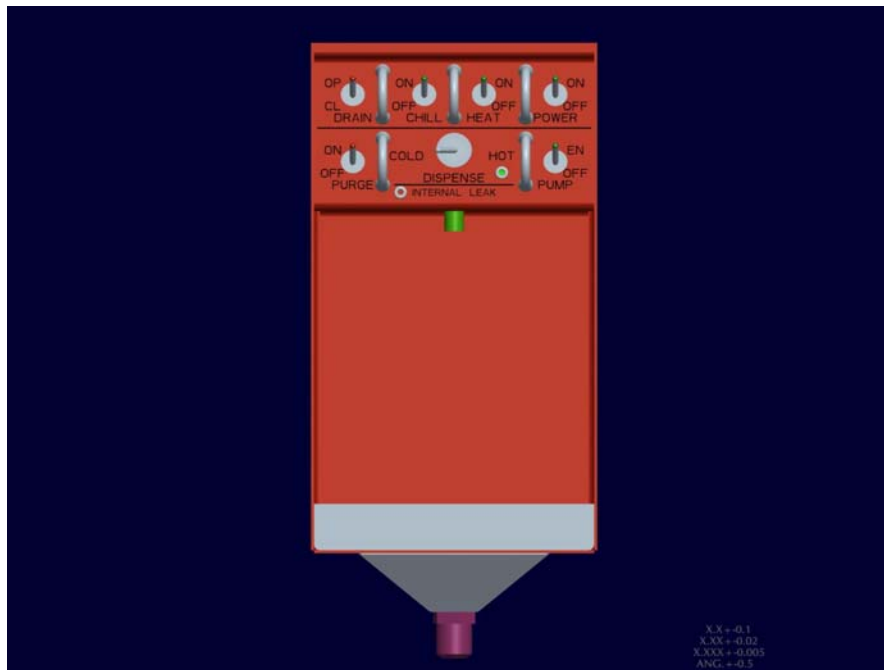

Figure 6: PWS dispense panel.<sup>7</sup>

#### 4. Desert Research And Technology Studies (DRATS) Testing

During testing in December 2011 and January 2012, Desert Research And Technology Studies (DRATS) testing was conducted at NASA Johnson Space Center in the building 9N high bay with the GEN IIA SEV. The test duration was 3 days. Each test consisted of 2 crew both astronauts and engineers. During the test the crew commented on the functionality and recommended improvements of PWS. In the test debrief, the vehicle team discussed an event where the drain was clogged with food waste during testing. A removable mesh screen will be implemented as part of the design to prevent food waste from entering the drain. Also, the pump would go to reset mode very often during use of the PWS. This is being investigated further and changes will be incorporated into future designs. Some recommendations were made about the control panel nomenclature.

### B. Waste Collection System

#### 1. General Functional Description

The WCS is a designated volume for the collection and stowage of human metabolic waste in the SEV. The WCS is approximately 0.13 m<sup>3</sup> (~21in. x 22.9 in. x 16 in.) and is located at the aft end of the vehicle aisle way as shown in Fig. 7.

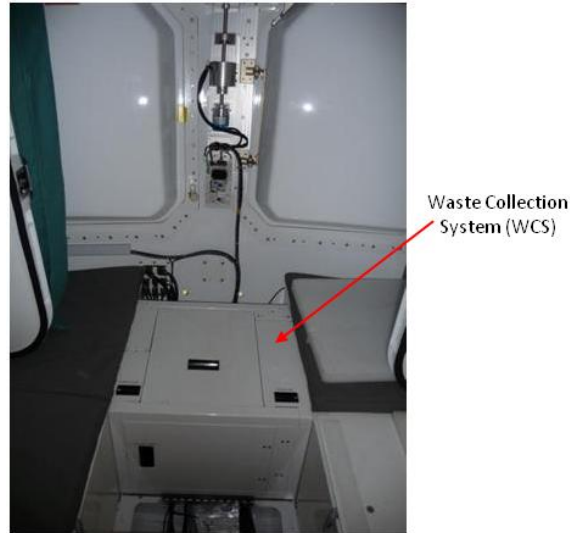

**Figure 7. SEV WCS location.**

The SEV WCS is designed to collect urine and fecal waste separately within the system. The crew uses waste alleviation gelling (WAG) bags to collect and dispose of fecal waste. Each WAG bag contains Poo Powder<sup>®</sup> (Cleanwaste, Belgrade, MT) – a powder treatment that gels and solidifies liquid waste. After the bag has been used, it is placed in metabolic waste bin within the WCS (see Fig. 8). Urine is collected and stored in a urine tank via a urinal funnel and hose (see Fig. 9). Each crewmember is provided a personal Space Shuttle-style urinal funnel to use for urination activities in the SEV. The tank is sized to hold up to 15.1 L (4 gal.) of urine and is removable via a front access panel. During the ground test mission, a suit port transfer module is connected to the suit port and the urine tank and wet, dry and metabolic trash is removed from the vehicle. The tank is changed out approximately every 3 days (see Fig. 9) and contains Poo Powder<sup>®</sup> to alleviate odors and solidify the urine to eliminate sloshing during tank removal from the system.

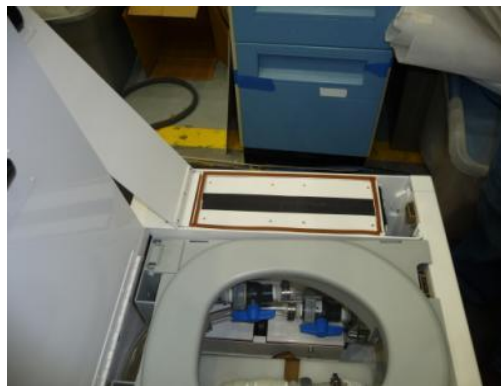

**Figure 8. View of the waste bin with access panel opened.**



**Figure 9. Internal view of the WCS.**

## 2. Waste Control System Odor Control

An active odor control system was integrated into the WCS to assist in the removal of immediate odors as well as odors from the stored waste and urine. The system consists of a fan duct box that contains a small fan and approximately 5.08 cm (~2 in.) of activated carbon filters for odor absorption. The fan pulls air from the urine tank, toilet seat, and metabolic waste bin in the WCS. The air is pulled through the activated carbon filters that “scrub” the air to remove odors. The “scrubbed” air is then vented back into the SEV cabin. The fan is powered by the SEV power and runs off of 12-volt direct current. An on/off switch for the fan is provided on the back panel of the WCS; the fan is powered on only during WCS use.

## 3. System Sizing

The WCS was oversized to accommodate metabolic waste for three crewmembers for 3 days. Per requirements in the CxP 70024, Constellation Program Human-Systems Integration Requirements, the metabolic waste bin was sized to allow for two defecations per day per crewmember with the solid waste removed from the vehicle every 3 days. It was determined that the waste volume, not including consumables for three crewmembers for 3 days, is approximately 0.001 m<sup>3</sup> (~82.4 in.<sup>3</sup>). The waste bin provides a total volume of 0.009 m<sup>3</sup> (540 in.<sup>3</sup>) to store solid waste as well as used consumables.

The urine tank was oversized to store urine for three crewmembers for 3 days. Per CxP 70024 requirements, the tank was sized to hold 2 L (0.528 gal.) of urine per day per crewmember. For a 3-day mission, the tank would have to accommodate 12 L (3.17 gal.) of urine. The actual urine tank incorporated into the design can store up to 15.1 L (4 gal.).

## 4. Desert Research And Technology Studies (DRATS) Testing

During testing, the crew provided both positive and negative feedback on the WCS functionality and ease of use. The crew commented that the WCS layout was comfortable and the addition of separating solid and liquid waste was a significant improvement from past systems. The urinal funnel and hose used for the collection of liquid waste was also a significant improvement and received excellent crew feedback. The crew did comment negatively on the overall size of the metabolic waste bin. They felt that the small bin size made it difficult to access, and the volume was not adequate for storing solid waste for 3 days. It was recommended to increase the overall bin volume for easier access.

## 5. Trash Compartment

The SEV trash compartment is a volume of approximately 0.036 m<sup>3</sup> (~22 in. x 8 in. x 12.5 in.) and is used to collect and store wet and dry trash. Wet trash includes such items as food packaging, wet wipes, and drink bottles. Dry trash includes such things as plastic packaging, cardboard, and paper items. The bin is located on the port side of the SEV directly behind the crewmember’s seat (see Fig. 10). The total trash volume was sized based on the total trash collected during Desert Research And Technology Studies testing in 2010. During testing, approximately 0.006 m<sup>3</sup> (366 in.<sup>3</sup>) of trash was collected per crewmember per day. It was determined that for a 3-day mission, the crew of two would require a volume of 0.036 m<sup>3</sup> (2,196.9 in.<sup>3</sup>) for trash stowage.



**Figure 10. Trash compartment (view from aisle).**

The bin is divided into two compartments with separate lids to separate wet and dry trash within the bin (see Fig. 11). The bin is lined with a permanent liner to prevent trash from leaking into the vehicle. Removable trash bags are placed inside the liner to contain trash and make for easy removal during trash collection. The trash is removed from the vehicle every 3 days. Passive odor control is provided in the trash bin via activated carbon filters in both the wet and dry trash areas. The filters are located on the trash compartment lids as shown in Fig. 12.



**Figure 11. Trash compartment (extended into aisle).**



**Figure 12. Trash compartment with lids opened.**

#### 6. *Research and Technology Studies Testing*

During the Research and Technology Studies testing in December 2011 and January 2012, the trash compartment was rated positively by both crews. The crews commented that the design of the trash drawer was brilliant and easy to access. The crew did recommend swapping the locations of the dry and wet trash since the dry trash was accessed more often. The crew would also prefer to have all “smelly” trash (wet and waste trash) centralized in one location. A recommendation was made to look at updating the gasket that holds the trash bag in place to a magnetic gasket to provide a more secure method for holding the trash bag in place.

### V. Conclusion

Trade studies, analyses, and prototype designs have been accomplished between 2009 and 2011 to aid with the development of the ECLSS design and evolve it toward a final flight design. The PLSS commonality study identified that using the complete PLSS as the cabin ECLSS was not practical to help reduce system mass power and volume. However, the study did identify that PLSS parts could potentially be implemented in the ECLSS design. The PLSS fan trade discovered the incompatibility of the PLSS fan to support the ARS ECLSS. The cascade analysis compared a cascade system, conventional high pressure/low pressure tank system, and dual tank compressor system. The Cascade system traded well for missions less than 14 days but for a 28 day mission duration a dual tank/compressor system traded slightly better. ECLSS hardware was designed for the GEN IIA version of the SEV. The PWS, WCS, and Trash prototypes were developed to support the DRATS ground testing and evolve the systems along the path of developing the flight design. Future work includes several modifications to the PWS, WCS and trash designed for GEN IIA, development of a Pressure Control System (PCS) model to trade the PLSS regulator for use in the cabin ECLSS, and continuation of the cascade analysis with O<sub>2</sub> tanks at 5000 psi.

### VI. References

<sup>1</sup>Bagdigian, Robert, Stambaugh, Imelda, “An Environmental Control and Life Support System Concept for a Pressurized Lunar Rover”, AIAA 2010-6256, 40<sup>th</sup> International Conference on Environmental Systems, Barcelona, Spain, 2010.

<sup>2</sup>Eckhardt, Brad, “Thermal Desktop Pressure Control System Model for the Crew Exploration Vehicle: ARS and Suit Loop Development for an ISS Leak Check Operation Test Case, FY 2010 Status”, ESCG-4470-10-EAN-DOC-0153, September 30, 2010.

<sup>3</sup>Varhese, Mini M., Mulloth, Lila M., Luna, Bernadette, and Hogan, John “Development Status of a Low-Power CO<sub>2</sub> Removal and Compression System for Closed-Loop Air Revitalization”, AIAA 2010-6060, 40<sup>th</sup> International Conference on Environmental Systems, Barcelona, Spain, 2010.

<sup>4</sup>Perma Pure LLC, Moisture Exchanger, Drawing # PR-178-02-01<sup>5</sup>Howard, D. F., Perry, J. L., Knox, J. C., and Junaedi, C., “Engineered Structured Sorbents for the Adsorption of Carbon Dioxide and Water Vapor from Manned Spacecraft Atmospheres: Applications and Testing 2008/2009,” 2009-01-2444, SAE, 39<sup>th</sup> International Conference on Environmental Systems, Savannah, Georgia, 2009.

<sup>6</sup>Sankaran, S., “Optimizing Cascade Oxygen Tanks to Meet SEV’s 3, 7, 14, and 28 days IVA/EVA Oxygen Needs”, Jacobs Technology, ESCG, Houston, TX September 2010.

<sup>7</sup>Buffington, J., “MMSEV Gen II Cabin A Potable Water System Standard Operating Procedure”, NASA JSC, Houston, TX, December 2011.