

Axel co-locates its sensors, actuators, electronics, power, and payload inside the central cylinder and science bays. This configuration provides compactness for launch, and robustness against environmental extremes in planetary missions. The Axel rover is equipped with science instruments, computational and communication modules, stereo cameras, and an inertial sensor for autonomous navigation with obstacle avoidance. Conductors inside the tether allow for the deployed Axel to be charged from and

communicate with the parts of the system that remain topside.

A mission can use a single or multiple low-mass Axel rovers to explore and sample high-risk sites. This class of rovers provides new capabilities for steep terrain and cave exploration and sampling beyond what is offered by current state-of-the-art rovers.

This work was done by Issa A. Nesnas, Jaret B. Matthews, Jeffrey A. Edlund, Joel W. Burdick, and Pablo Abad-Manterola of Caltech for NASA's Jet Propulsion Laboratory. Further information is contained in a TSP (see page 1).

In accordance with Public Law 96-517, the contractor has elected to retain title to this invention. Inquiries concerning rights for its commercial use should be addressed to:

*Innovative Technology Assets Management
JPL*

*Mail Stop 202-233
4800 Oak Grove Drive
Pasadena, CA 91109-8099*

*E-mail: iaoffice@jpl.nasa.gov
Refer to NPO-47890, volume and number of this NASA Tech Briefs issue, and the page number.*

⚙️ Site Tamper and Material Plow Tool — STAMP

Tool simplifies measurement of surface samples.

NASA's Jet Propulsion Laboratory, Pasadena, California

A non-actuated tool has been developed for preparing regolith for in situ measurement by smoothing uneven surfaces and excavating fresher subsurface material for planetary exploration. The STAMP tool contains two tools to prepare regolith for in situ measurement: a tamper to smooth uneven surfaces, and a blade to excavate fresher subsurface material.

The STAMP design leverages flight-proven design features and flight-qualified components from Mars Exploration Rover (MER) and Phoenix missions to provide a reli-

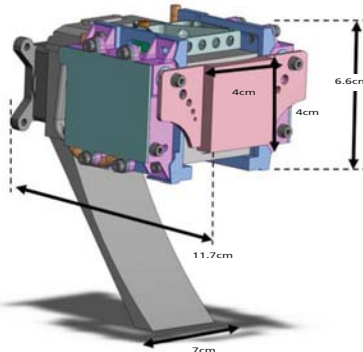

The STAMP Tool contains a tamper to smooth uneven surfaces, and a blade to excavate fresher subsurface material.

able, non-actuated tool. The STAMP tool can be mounted at the end-effector of a robotic arm that supports deployment of contact instruments. Using the rotation of the end-effector, either the tamper or blade can be deployed to prepare regolith for in situ measurement.

This work was done by Norman M. Aisen, Curtis L. Collins, and Ashitey Trebi-Ollennu of Caltech for NASA's Jet Propulsion Laboratory. For more information, contact iaoffice@jpl.nasa.gov. NPO-47742

⚙️ Magnetic Interface for Segmented Mirror Assembly

Marshall Space Flight Center, Alabama

Newly developed magnetic devices are used to create an interface between adjacent mirror segments so that once assembled, aligned, and phased, the multiple segments will behave functionally equivalent to a monolithic aperture mirror. One embodiment might be a kinematic interface that is reversible so that any number of segments can be pre-assembled, aligned, and phased to facilitate fabrication operations, and then disassembled and reassembled, aligned, and phased in space for operation.

The interface mechanism has sufficient stiffness, force, and stability to maintain phasing. The key to producing an interface is the correlated mag-

netic surface. While conventional magnets are only constrained in one direction — the direction defined by their point of contact (they are in contact and cannot get any closer) — correlated magnets can be designed to have constraints in multiple degrees of freedom. Additionally, correlated magnetic surfaces can be designed to have a limited range of action.

Finally, via the use of electromagnets, the rate of closure or separation of correlated magnetic surfaces can be controlled. Once the interface is established, mechanisms will adjust the segment alignment relative to each other to establish phasing. Once phas-

ing is established, the correlated magnetic surfaces have sufficient axial and lateral force to maintain that alignment in the microgravity environment of space. Additionally, beyond providing a hard interface, the axial and lateral force (spring constants) of the correlated magnetic surfaces can be designed to provide a very stiff or very soft interface. The net effect is similar to a kinematic mechanical flexure system, a tuned dampener, or shock absorber.

This work was done by H. Stahl of Marshall Space Flight Center. For more information, contact Sammy Nabors, MSFC Commercialization Assistance Lead, at sammy.a.nabors@nasa.gov. Refer to MFS-32917-1.