



Calibration Procedure for Measuring S-Parameters in Balun Applications on 150- Ω High-Speed Cables

*Onoufrios Theofylaktos and Joseph D. Warner
Glenn Research Center, Cleveland, Ohio*

NASA STI Program . . . in Profile

Since its founding, NASA has been dedicated to the advancement of aeronautics and space science. The NASA Scientific and Technical Information (STI) program plays a key part in helping NASA maintain this important role.

The NASA STI Program operates under the auspices of the Agency Chief Information Officer. It collects, organizes, provides for archiving, and disseminates NASA's STI. The NASA STI program provides access to the NASA Aeronautics and Space Database and its public interface, the NASA Technical Reports Server, thus providing one of the largest collections of aeronautical and space science STI in the world. Results are published in both non-NASA channels and by NASA in the NASA STI Report Series, which includes the following report types:

- **TECHNICAL PUBLICATION.** Reports of completed research or a major significant phase of research that present the results of NASA programs and include extensive data or theoretical analysis. Includes compilations of significant scientific and technical data and information deemed to be of continuing reference value. NASA counterpart of peer-reviewed formal professional papers but has less stringent limitations on manuscript length and extent of graphic presentations.
- **TECHNICAL MEMORANDUM.** Scientific and technical findings that are preliminary or of specialized interest, e.g., quick release reports, working papers, and bibliographies that contain minimal annotation. Does not contain extensive analysis.
- **CONTRACTOR REPORT.** Scientific and technical findings by NASA-sponsored contractors and grantees.

- **CONFERENCE PUBLICATION.** Collected papers from scientific and technical conferences, symposia, seminars, or other meetings sponsored or cosponsored by NASA.
- **SPECIAL PUBLICATION.** Scientific, technical, or historical information from NASA programs, projects, and missions, often concerned with subjects having substantial public interest.
- **TECHNICAL TRANSLATION.** English-language translations of foreign scientific and technical material pertinent to NASA's mission.

Specialized services also include creating custom thesauri, building customized databases, organizing and publishing research results.

For more information about the NASA STI program, see the following:

- Access the NASA STI program home page at <http://www.sti.nasa.gov>
- E-mail your question via the Internet to help@sti.nasa.gov
- Fax your question to the NASA STI Help Desk at 443-757-5803
- Telephone the NASA STI Help Desk at 443-757-5802
- Write to:
NASA Center for AeroSpace Information (CASI)
7115 Standard Drive
Hanover, MD 21076-1320



Calibration Procedure for Measuring S-Parameters in Balun Applications on 150- Ω High-Speed Cables

*Onoufrios Theofylaktos and Joseph D. Warner
Glenn Research Center, Cleveland, Ohio*

National Aeronautics and
Space Administration

Glenn Research Center
Cleveland, Ohio 44135

Trade names and trademarks are used in this report for identification only. Their usage does not constitute an official endorsement, either expressed or implied, by the National Aeronautics and Space Administration.

Level of Review: This material has been technically reviewed by technical management.

Available from

NASA Center for Aerospace Information
7115 Standard Drive
Hanover, MD 21076-1320

National Technical Information Service
5301 Shawnee Road
Alexandria, VA 22312

Available electronically at <http://www.sti.nasa.gov>

Calibration Procedure for Measuring S-Parameters in Balun Applications on 150-Ω High-Speed Cables

Onoufrios Theofylaktos and Joseph D. Warner
National Aeronautics and Space Administration
Glenn Research Center
Cleveland, Ohio 44135

Summary

In the radiofrequency (RF) world, to characterize cables that do not conform to the typical 50-Ω impedance, a time domain reflectometer (TDR) would probably be the simplest and quickest tool to attain this goal. In the real world, not every engineer has a TDR at their disposal; however, they most likely have a network analyzer available. Given a generic 50-Ω vector network analyzer (VNA), we would like to make S-parameter measurements for non-50-Ω devices (DUTs). For that, we utilize RF balanced/unbalanced transformers (called baluns for short), which are primarily used to match the impedance between the two VNA ports and the DUT's input and output ports, for the two-port S-parameter measurements.

1.0 Introduction

Quadrx cables are being used to transfer data at a high rate in the hundreds of megabits per second. Quadrx cables consist of four wires twisted together around a pliable center low-loss dielectric with an outer low-loss dielectric, which is surrounded by a flexible metal shield. Figure 1 presents a cross-sectional view of a 150-Ω quadrx cable made by W.L. Gore & Associates, Inc.

NASA had chosen to use these Gore cables in the Service Module (SM) of the Ares 1 rocket. The quadrx cable length could be up to 30 m long and could withstand launch vibrations of 50 g or more. The vibration effects on the transmission coefficient (S_{21}) of the cables were unknown. Therefore, a method was developed to test these cables to determine the change in the transmission coefficient and its effect on the bit error rate (BER) at the maximum vibration level achievable at the NASA Glenn Vibration Facility.

The prototype cables tested consisted of quadrx cables from Gore to be space qualified. The cables obtained were in the length of 1 m, 4 m, and 8 m with male and female quadrx connectors (one on each end of the individual cables). In addition, two of the quadrx cables were less than 1 m long (~60 cm) and had four unterminated wires on one end and a male/female (M/F) quadrx connector at the other.

To determine the effect of the vibration, it was decided to measure the increase in noise for the transmission coefficient S_{21} and the change of the transmission coefficient from no vibration to vibration levels of 32 g. Then, we related that change in the noise to determine the effect on the BER.

The method chosen to determine the change in the noise level was to make analog measurements using a vector network analyzer (VNA) and then to relate the change in noise level to the BER using another published paper (Ref. 1).

2.0 Experimental Procedure

Two sets of cables were used for the vibration tests. One set had 26-gauge wires for the 4 conductors, and the other set had 24-gauge wires. The 26-gauge cables could not provide a link with a cable length of 30 m that would have a BER of 10^{-8} even without vibrating the cable. Only the 24-gauge cables were tested for the effects of vibration on the noise level of the link. These cables had a nominal impedance of 150 Ω.

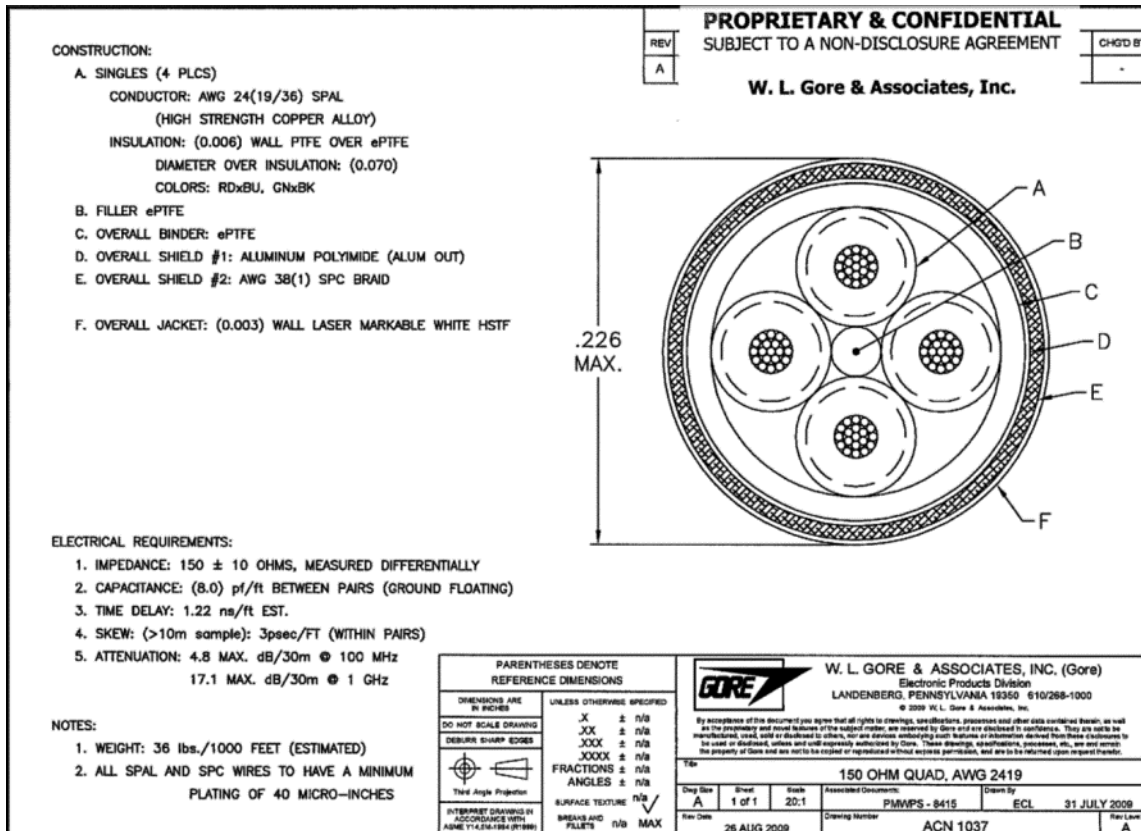

Figure 1.—Cross-sectional view of Gore ACN 1037 quad coax cable (W.L. Gore & Associates, Inc.; used with permission).

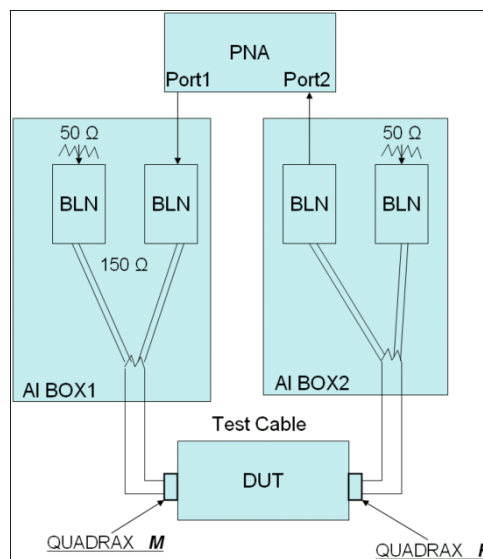

Figure 2.—Experimental setup with vector network analyzer (VNA) and four baluns.

The experimental setup consisted of an Agilent VNA (N5230A, 20 GHz, S/N: MY46400910, Agilent Calibration: 1-2869640062-1 on 21-DEC-2010) and four balanced-to-unbalanced transformers (baluns). The impedance on the balanced side of the balun was 150 Ω, and on the unbalanced side it was 50 Ω. Between the baluns were the transition cables and the cable under test (DUT). A schematic of the experimental setup is depicted in Figure 2.

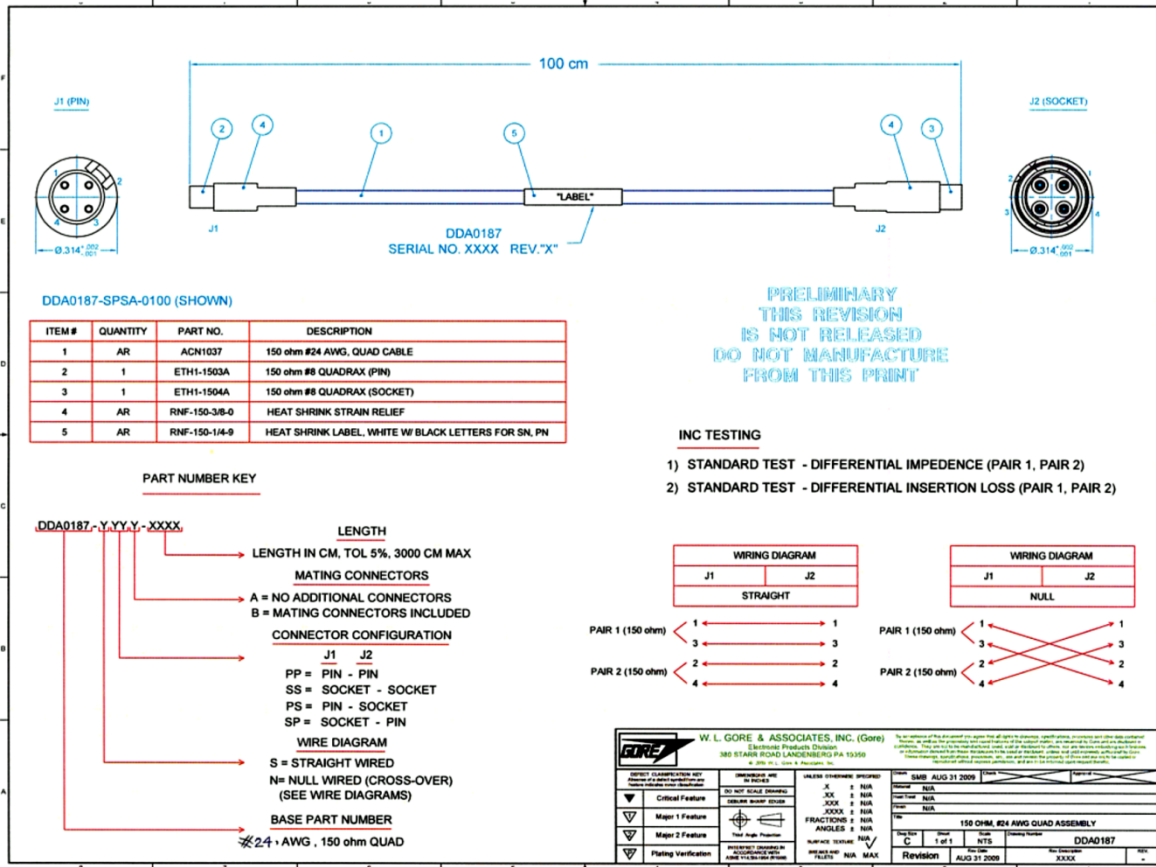

Figure 3.—Sample test cable schematic from W.L. Gore & Associates, Inc. (W.L. Gore & Associates, Inc.; used with permission).

TABLE I.—CABLE DESCRIPTIONS

Cable name	Length, m	Part number
DUT1	8	DDA0187-SPSA-0800 REV.B S/N: 3214732-01 Quadrax [M/F]
DUT2	8	DDA0187-SPSA-0800 REV.B S/N: 3214732-02 Quadrax [M/F]
DUT1	4	DDA0187-SPSA-0400 REV.B S/N: 3214734-01 Quadrax [M/F]
DUT1	1	DDA0187-SPSA-0100 REV.B S/N: 3214731-01 Quadrax [M/F]

Figure 3 shows a schematic of the cables. The cables tested in this work are shown in Table I. The cable adapters (transition or pigtail cables) had the following part numbers:

- Quadrax [M/Pigtail]: DDA0187-SPSA-0061_J1 REV.0 (S/N: 3214735-01)
- Quadrax [F/Pigtail]: DDA0187-SPSA-0061_J2 REV.0 (S/N: 3214735-02)

The baluns were obtained from Pulse Engineering under part number HFB050150. The specification of the balun gave a maximum operating frequency of 1.2 GHz; in our experiment we had to limit the maximum frequency to 900 MHz because of anomalies in the baluns' performance above 900 MHz.

The turns ratio of the transformers used was 3. Each transformer was packaged by Pulse Engineering with a 50-Ω small microwave adapter (SMA) connector at the one port (primary) and three 33-mil inside diameter sockets at the 150-Ω port (secondary). The middle socket was internally connected to the primary ground, which was the same as the SMA shield (Figure 4).

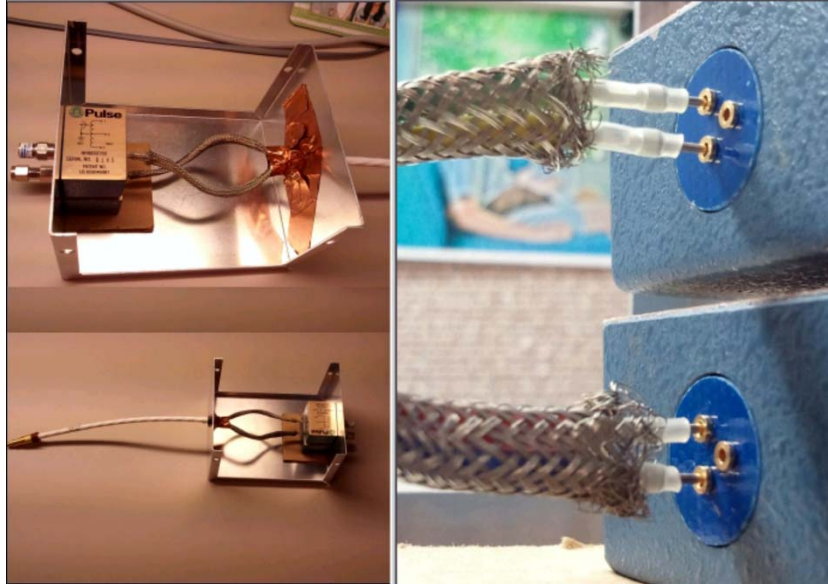

Figure 4.—Construction of balun Box1 and Box2.



Figure 5.—Typical calibration with balun Box1 and Box2 connected via pigtail cables and terminated in 150- Ω , open, or short load.

Cables with pigtails from Gore were used to connect the two baluns together, back to back (Figure 5). These 0.6-m pigtail cables are part numbers DDA0187-SPSA-0061_J1 (one male number 8 quadrx connector) and DDA0187-SPSA-0061_J2 (one female number 8 quadrx connector). The pigtails are also labeled as 3214735-02. The choice of pigtail cables, specifically the quadrx connector ends, was dictated by the DUT test cable configuration (M/F).



Figure 6.—Open, short, and wide-load terminations for 150- Ω vector network analyzer (VNA) calibration.

There was no equipment available at our disposal that would allow us to make direct measurements at 150 Ω . Therefore, we decided to design a circuit with baluns that would match our 150- Ω cables to the VNA. After creating a “calibration kit” to be able to calibrate the VNA while using the baluns and moving the calibration plane to the point of inserting the cable under test between the pigtail cables off of the baluns, we were able to measure the properties of the cable under test. The pigtails were connected to the secondary balun ports by way of the three pins (Figure 4). Two of the pins were the signal pair, and the third pin was the cable shield. Each pigtail cable was connected to one balun box (Figure 5).

Figure 5 displays the setup of the measurement to calibrate the system before the cables under test (DUTs) were added. Inside each aluminum box there were two baluns. Because we used four baluns, the pair of wires not being measured was terminated in 50 Ω to reduce the standing waves in the pair being measured.

To calibrate the VNA at 150 Ω , we built terminations for our pigtail cables. These terminations (Figures 5 and 6) are simple quadrx connectors (one male and one female) with loads that have the following attributes:

- The OPEN pair of connectors was left unchanged.
- The SHORT pair was shorted inside the shell by way of a 24-gauge jumper wire between the conductors of a wire pair; each wire pair was shorted individually.
- The LOAD pair was made with Vishay-Dale 150- Ω Surface Mount Thin Film 0.1% Precision Resistors 0603, 1/10W, 25ppm, (P/N: TNPW0603), with one resistor soldered across each wire pair.

3.0 Setting up the VNA for the Double Calibration Task

We used the standard calibration procedure to calibrate the cables and to move the calibration plane to the end of the quadrax pigtail cables.

3.1 Standard 50-Ω VNA Calibration

1. Specify frequency range, power level, points, and intermediate frequency (IF) bandwidth.

Channel frequency start/stop	100 to 2000 MHz
Channel power channel 1	-10 dBm
Sweep number of points	6401
Sweep IF bandwidth	1.0 KHz

2. Calibrate out VNA cables with 50-Ω calibration kit.

Calibration Cal Wizard: UNGUIDED, 2 Port Solt, 85052D 3.5 mm Cal Kit
(Save as: CaliNoBaluns)

3. Make sure this calibration produces a flat S_{11} magnitude around -70 dB and approximately zero S_{11} phase variation over the entire test bandwidth.

This procedure established that the VNA is working as expected. The next part of the procedure is to pick out the best pair of baluns that will work with our VNA. As it turned out, 2 of the 10 baluns we acquired became nonusable in a few weeks. The remaining eight had the part numbers 0135, 0136, 0137, 0139, 0140, 0141, 0142, and 0145.

3.2 Balun Characterization and Selection, 150-Ω Calibration

The next part of the procedure was to characterize and then select the best baluns to be used to measure the cables. The frequency attributes we were looking for in the baluns over their entire operating range had the following criteria:

- Slow variation in the S_{11} parameters; no large peaks or valleys desired
- Low S_{11} magnitude and S_{11} phase of about zero but most importantly, no large peaks

The procedure is as follows:

1. Place balun circuits between VNA cables as shown in Figure 5.
2. Measure 2-port S-parameters of balun ensemble using VNA.
3. Assembly/disassembly for verification of the repeatability of measurement.
4. Establish balun ensemble useful bandwidth (new frequency range).
5. Best balun pair range: 100 to 900 MHz (based on the above criteria).
6. Calibrate out VNA cables with balun ensemble broken up
(Save as: CaliYesBaluns)
7. Each balun (M/F) should be terminated using 150-Ω connector terminations, prior to testing any Gore cables.

3.3 Final 150-Ω VNA Calibration

After the matching of the baluns to give the best S_{11} parameters, the following calibration procedure was used before testing each cable and when additional calibration data was desired.

1. Place balun circuits between VNA cables as shown in Figures 5 and 7.
 - Bottom wire-pair in each box connected to VNA test cables
 - Optimum balun ensemble numbers 0140 and 0141
 - Balun number 0140 in Box1 and balun number 0141 in Box2
 - Each balun has a top and bottom 33 mil ID socket on 150-Ω side
 - RED_Wire_Top_Socket; BLUE_Wire_Bottom_Socket
 - Each balun has an SMA-female connector on the 50-Ω side
2. Specify frequency range, power level, points, and IF bandwidth.

Channel frequency start/stop	100 to 2000 MHz
Channel power channel 1	-10 dBm
Sweep number of points	6401
Sweep IF bandwidth	1.0 KHz

3. Calibrate out VNA cables with our own 150-Ω calibration kit.
 Calibration Cal Wizard: UNGUIDED, 2 Port Solt (Figure 6)
4. Measure 2-port S-parameters of balun ensemble using VNA.
5. Assembly and disassembly to verify repeatability of the measurement.
6. Establish balun ensemble useful bandwidth (new frequency range).
7. Calibrate out VNA cables with balun ensemble; each balun box.
 M/F should be terminated using 150-Ω terminations (Figures 5 and 7).

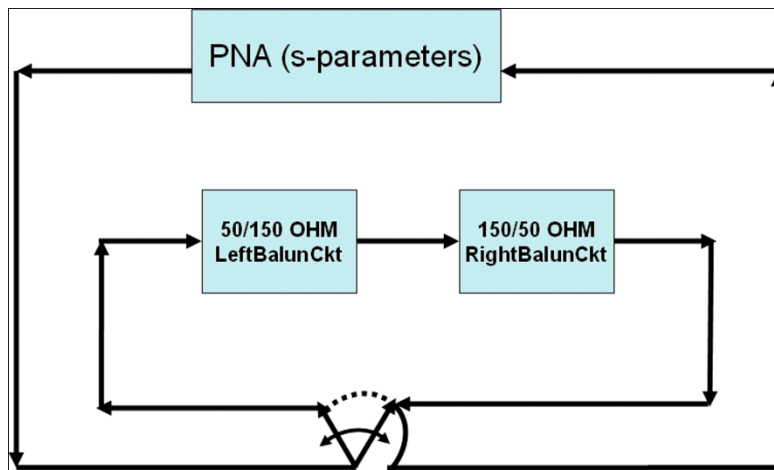

Figure 7.—Balun characterization and selection.

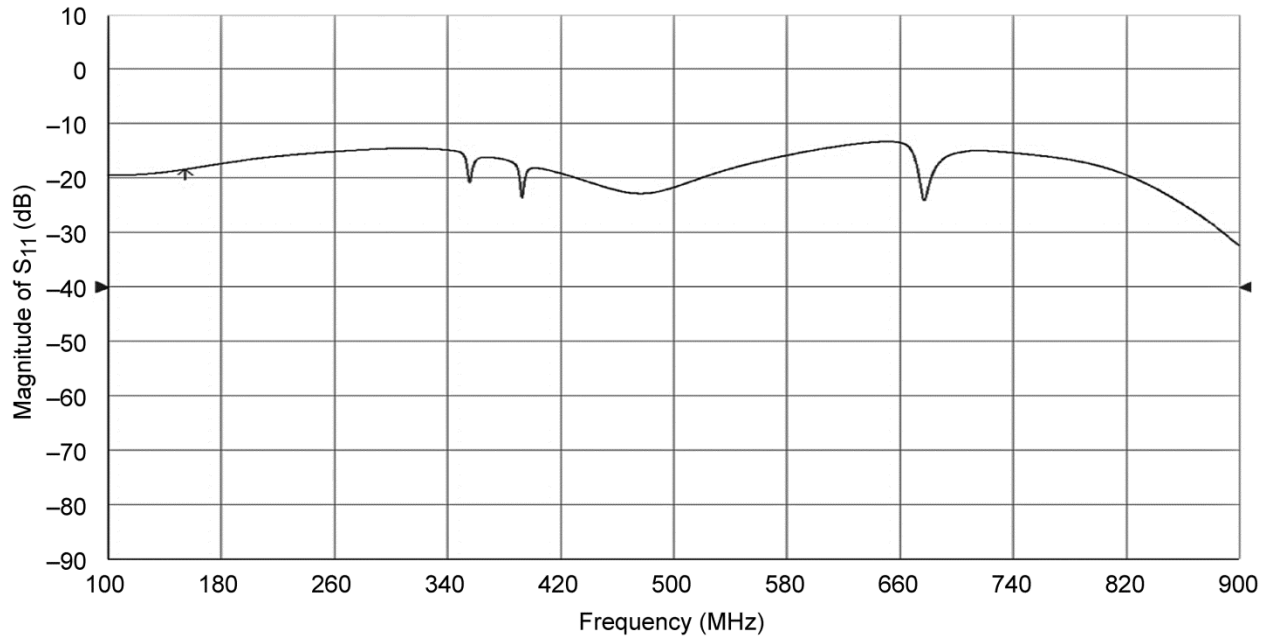

Figure 8.—Return loss (S_{11}) for balun number 0140—bottom connection Box1.

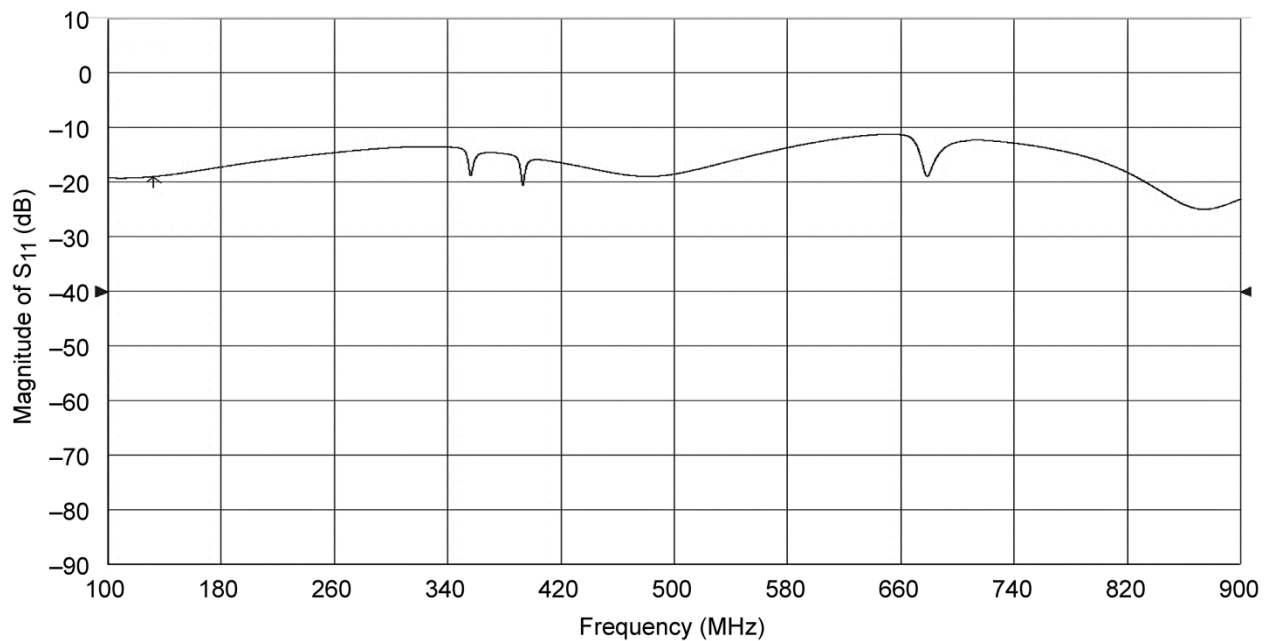

Figure 9.—Return loss (S_{11}) for balun number 0141—bottom connection Box2.

4.0 Results

Figures 8 and 9 present the S_{11} parameters on the baluns that were tested to make the final selection of the baluns to be used to test the quadrx cables.

When the pigtail cable wire pair in Box1 corresponding to the bottom baluns were connected, the results for 0140 and 0141, respectively, are depicted in Figures 10 and 11.

When the pigtail cable wire pair in Box1 corresponding to the top baluns were connected, the results for 0140 and 0141, respectively, are depicted in Figures 12 and 13.

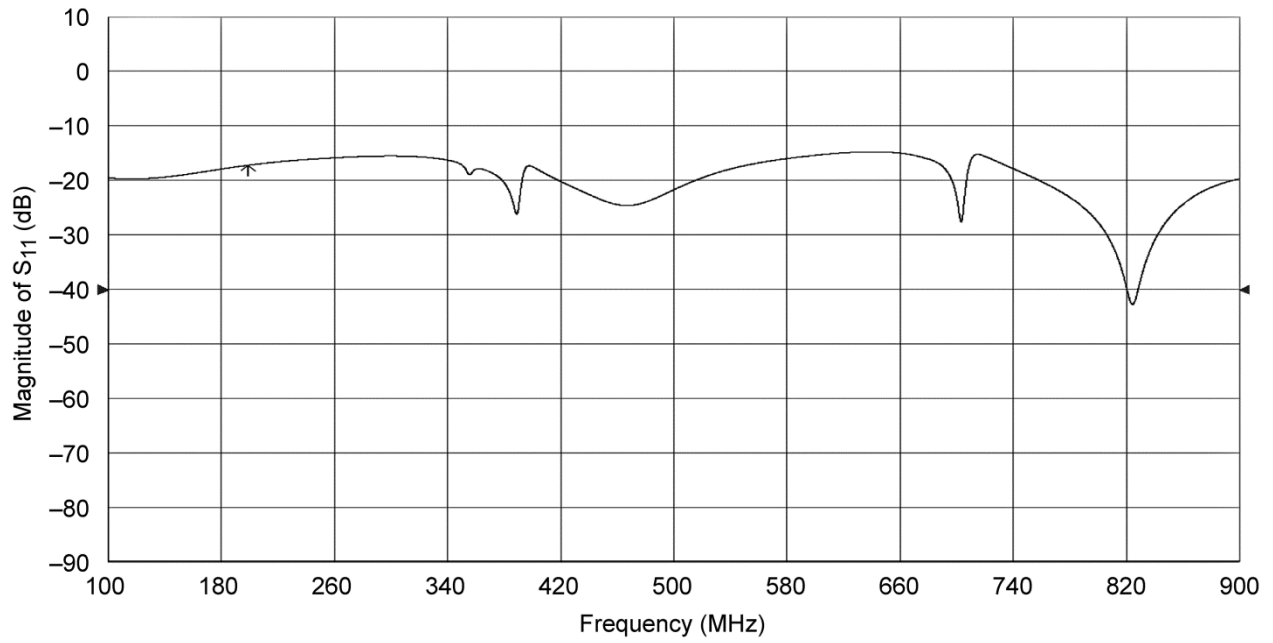

Figure 10.—Return loss (S_{11}) for balun number 0140—top connection Box1.

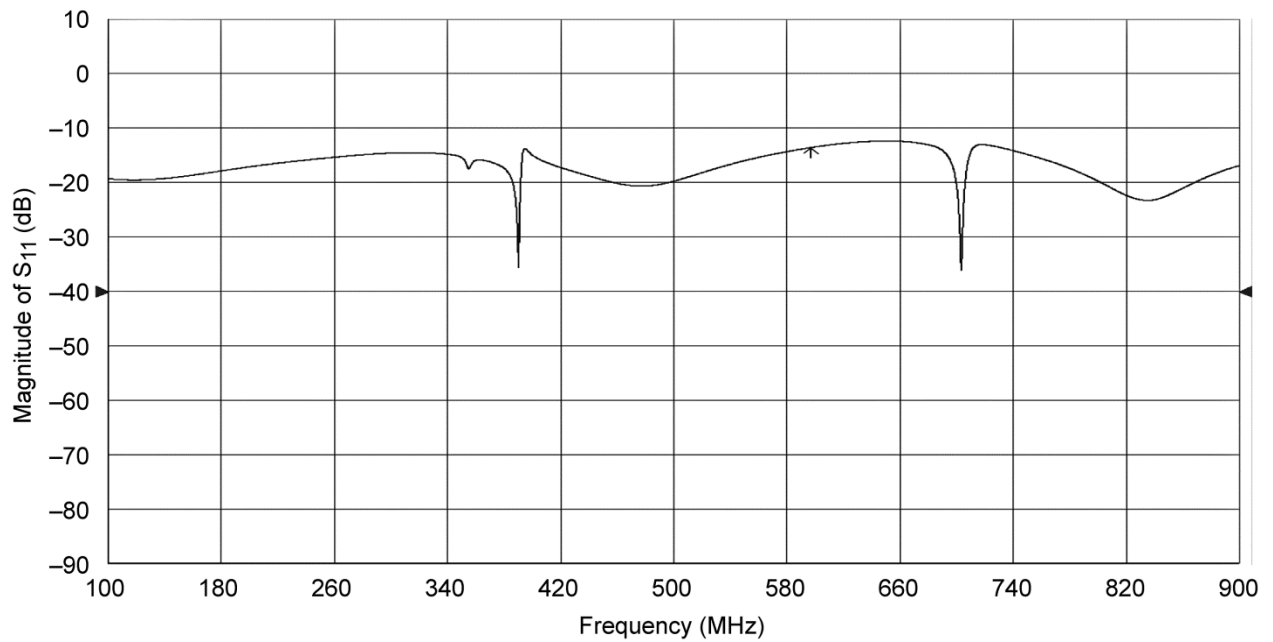

Figure 11.—Return loss (S_{11}) for balun number 0141—top connection Box2.

When Box1 (balun number 0140) and Box2 (balun number 0141) are connected via the 60-cm pigtail cables going through the VNA, then S_{11} and S_{21} are depicted in Figure 12, and S_{22} is depicted in Figure 13.

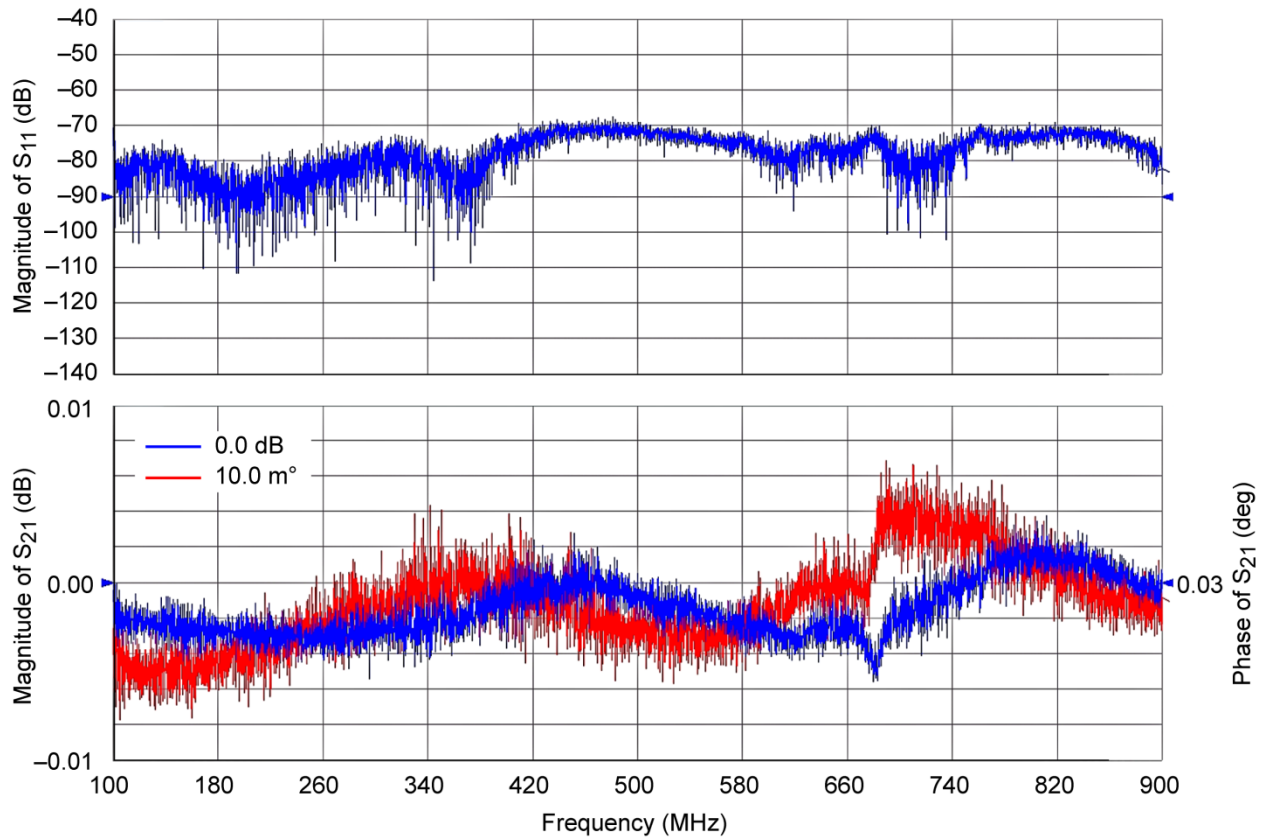

Figure 12.—Initial vector network analyzer (VNA) system calibration at 150 Ω . S_{11} amplitude noise floor -70 dB.

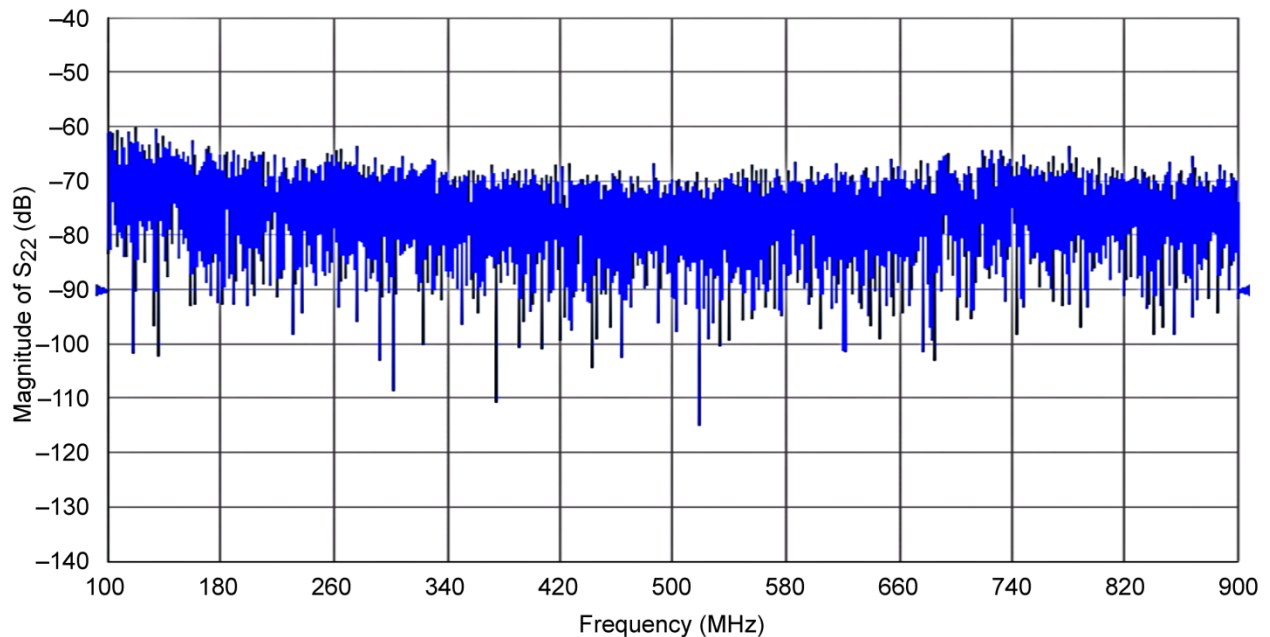

Figure 13.—Initial vector network analyzer (VNA) system calibration at 150 Ω . S_{22} amplitude noise floor -60 dB.

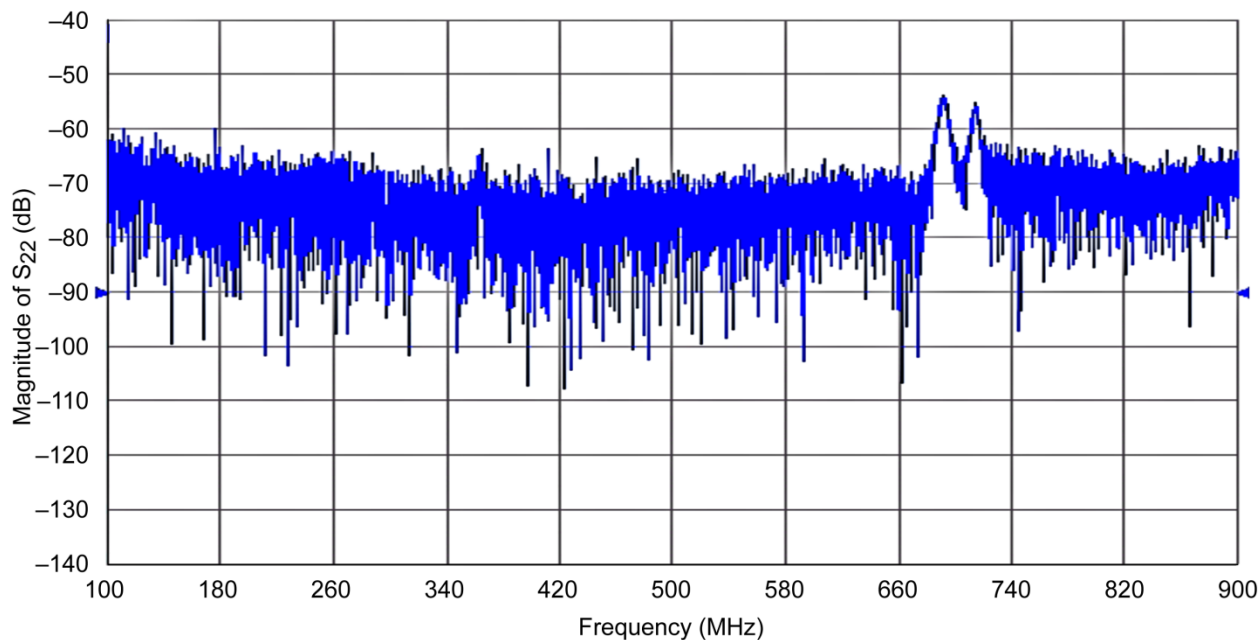

Figure 14.—Twenty minutes after initial vector network analyzer (VNA) system calibrations at 150 Ω .
 S_{22} amplitude noise floor -53 dB.

Twenty minutes later, when the plot of Figure 13 was remeasured, it produced the results shown in Figure 14.

5.0 Conclusion

Calibration of a vector network analyzer with an in-house-built 150- Ω calibration kit, with baluns purchased from Pulse Engineering, and pigtail quadrx cables purchased from Gore, was attained. Care was taken in finding a balun pair that would result in a stable calibration at 150 Ω . Out of a batch of 10 baluns, only two baluns were appropriate for the job, because they would not result in a flat calibration curve that was repeatable or sustainable over the duration of any of our vibration tests. Accordingly, optimization of balun properties and calibration approaches are required to obtain stable and reliable calibrations in a consistent basis. This practice is limited by the availability of baluns, their turns ratio, and flat bandwidth range when inserted in a calibration circuit. We were able to characterize our cables when subjected to 32-g levels of vibration. We determined that the cables were feasible to be used in the Service Module up to a length of 30 m.

Reference

1. Warner, Joseph D. and Theofylaktos, Onoufrios: Correlation Between Analog Noise Measurements and the Expected BER of a Digital Signal Propagating Through Passive Components: NASA/TM—2012-217238.

REPORT DOCUMENTATION PAGE			Form Approved OMB No. 0704-0188		
<p>The public reporting burden for this collection of information is estimated to average 1 hour per response, including the time for reviewing instructions, searching existing data sources, gathering and maintaining the data needed, and completing and reviewing the collection of information. Send comments regarding this burden estimate or any other aspect of this collection of information, including suggestions for reducing this burden, to Department of Defense, Washington Headquarters Services, Directorate for Information Operations and Reports (0704-0188), 1215 Jefferson Davis Highway, Suite 1204, Arlington, VA 22202-4302. Respondents should be aware that notwithstanding any other provision of law, no person shall be subject to any penalty for failing to comply with a collection of information if it does not display a currently valid OMB control number.</p> <p>PLEASE DO NOT RETURN YOUR FORM TO THE ABOVE ADDRESS.</p>					
1. REPORT DATE (DD-MM-YYYY) 01-04-2012		2. REPORT TYPE Technical Memorandum		3. DATES COVERED (From - To)	
4. TITLE AND SUBTITLE Calibration Procedure for Measuring S-Parameters in Balun Applications on 150-Ω High-Speed Cables			5a. CONTRACT NUMBER		
			5b. GRANT NUMBER		
			5c. PROGRAM ELEMENT NUMBER		
6. AUTHOR(S) Theofylaktos, Onoufriou; Warner, Joseph, D.			5d. PROJECT NUMBER		
			5e. TASK NUMBER		
			5f. WORK UNIT NUMBER WBS 789822.01.03.03		
7. PERFORMING ORGANIZATION NAME(S) AND ADDRESS(ES) National Aeronautics and Space Administration John H. Glenn Research Center at Lewis Field Cleveland, Ohio 44135-3191			8. PERFORMING ORGANIZATION REPORT NUMBER E-18024		
9. SPONSORING/MONITORING AGENCY NAME(S) AND ADDRESS(ES) National Aeronautics and Space Administration Washington, DC 20546-0001			10. SPONSORING/MONITOR'S ACRONYM(S) NASA		
			11. SPONSORING/MONITORING REPORT NUMBER NASA/TM-2012-217296		
12. DISTRIBUTION/AVAILABILITY STATEMENT Unclassified-Unlimited Subject Category: 32 Available electronically at http://www.sti.nasa.gov This publication is available from the NASA Center for AeroSpace Information, 443-757-5802					
13. SUPPLEMENTARY NOTES					
14. ABSTRACT In the radiofrequency (RF) world, in order to characterize cables that do not conform to the typical 50-Ω impedance, a time domain reflectometer (TDR) would probably be the simplest and quickest tool to attain this goal. In the real world, not every engineer has a TDR at their disposal; however, they most likely have a network analyzer available. Given a generic 50-Ω vector network analyzer (VNA), we would like to make S-parameter measurements for non-50-Ω devices (DUTs). For that, we utilize RF balanced/unbalanced transformers (called baluns for short), which are primarily used to match the impedance between the two VNA ports and the DUT's input and output ports, for the two-port S-parameter measurements.					
15. SUBJECT TERMS S-parameters; Balun; Cable; Gigabit					
16. SECURITY CLASSIFICATION OF:			17. LIMITATION OF ABSTRACT	18. NUMBER OF PAGES 17	19a. NAME OF RESPONSIBLE PERSON STI Help Desk (email: help@sti.nasa.gov)
a. REPORT U	b. ABSTRACT U	c. THIS PAGE U			UU

