



Glenn Research Center



## **Boiling eXperiment Facility (BXF)**

# **Fluid Toxicity Technical Interchange Meeting (TIM) with the Payload Safety Review Panel (PSRP)**

June 14, 2012



Glenn Research Center

# Agenda



- Introductions
- Experiment Overview
- ISS Operations and Anomalies Summary
- Post-Flight Assessment Process and Findings
- Applicable Unique Hazard Reports
- Conclusions and Lessons Learned
- Project Status



Glenn Research Center

# BXF Project Team Post-Flight ZIN Technologies



William A. Sheredy	Project Manager
Prof. Jungho Kim	Microheater Array Boiling Experiment (MABE) Principal Investigator
John B. McQuillen	MABE Project Scientist
Prof. Vijay Dhir	Nucleate Pool Boiling Experiment (NPBX) Principal Investigator
Dr. David F. Chao	NPBX Project Scientist

## ZIN Technologies Project Team (Post-Flight):

Raymond Pavlik	ZIN Project Lead
Wendell Booth	Lead Electrical Engineer
Kimesha Calaway	Safety Engineer
Sarah Czerwien	Operations Engineer
Jeff Eggers	Lead Software Engineer
Chris Lant	Optics Engineer
Kevin Magee	Lead Mechanical Engineer
Craig Totman	Instrumentation
Russell Valentine	Mechanical Engineer



Glenn Research Center

# BXF in the MSG Engineering Unit at MSFC

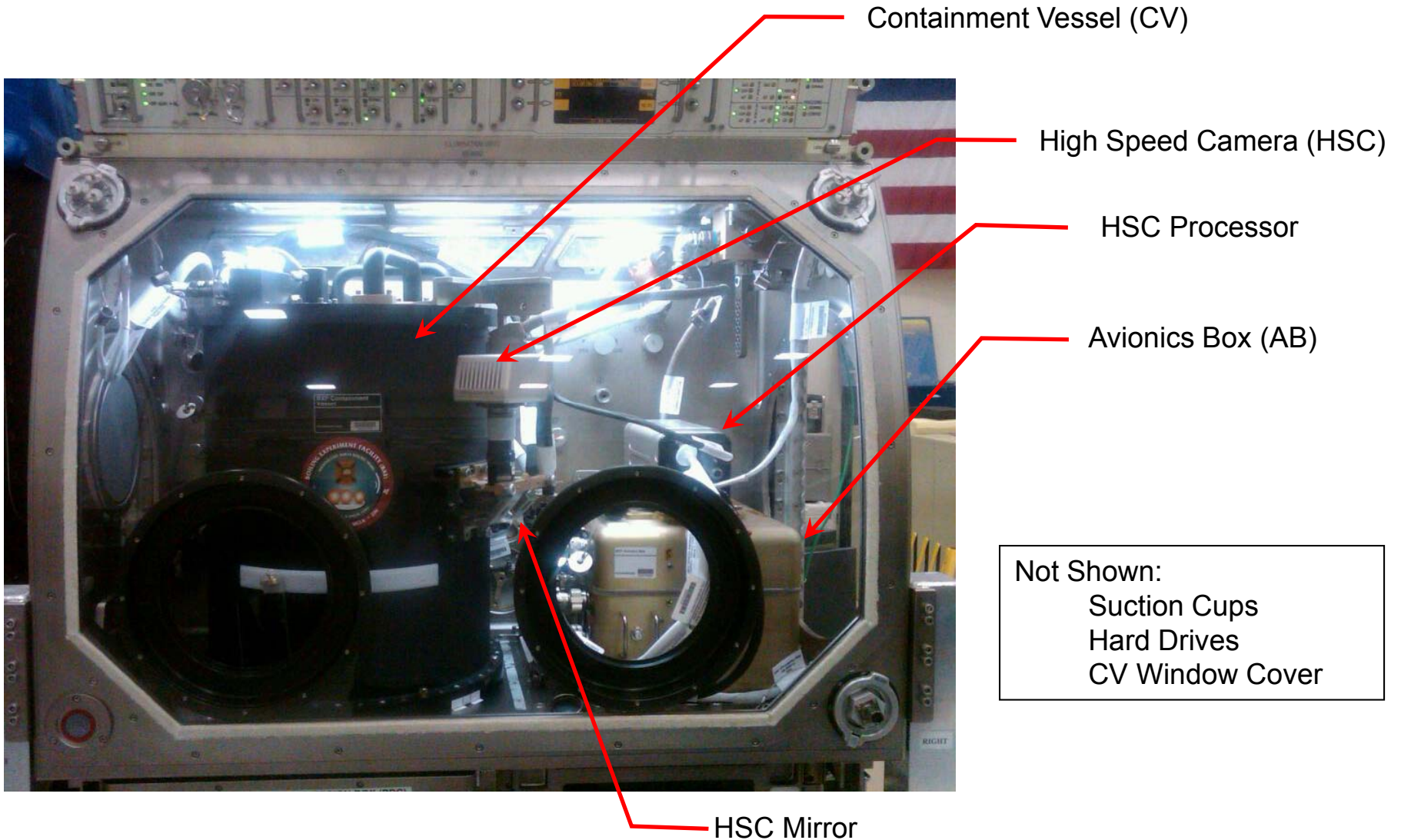

Not Shown:  
 Suction Cups  
 Hard Drives  
 CV Window Cover



Glenn Research Center

# Internals of the BXF Containment Vessel

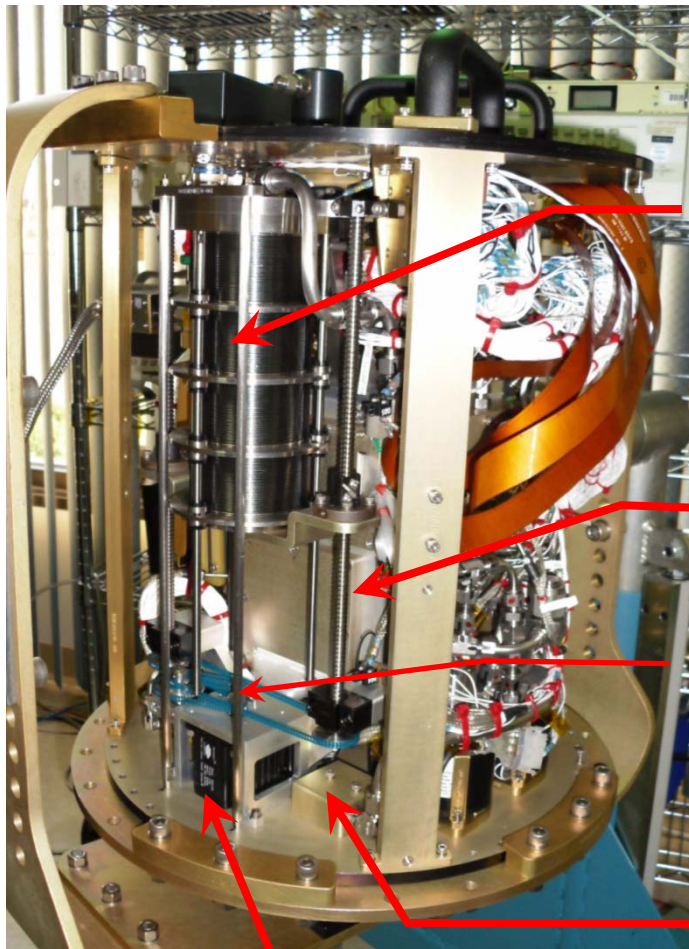

Additional components in the Fluid System:  
Thermistors  
Relief valve  
Pressure Transducers

Bellows

External Flex Circuits

MABE Cooling Chamber

Boiling Chamber

Drive System (bellows)

Pumps

Heat Exchanger

Servo Motor (bellows)

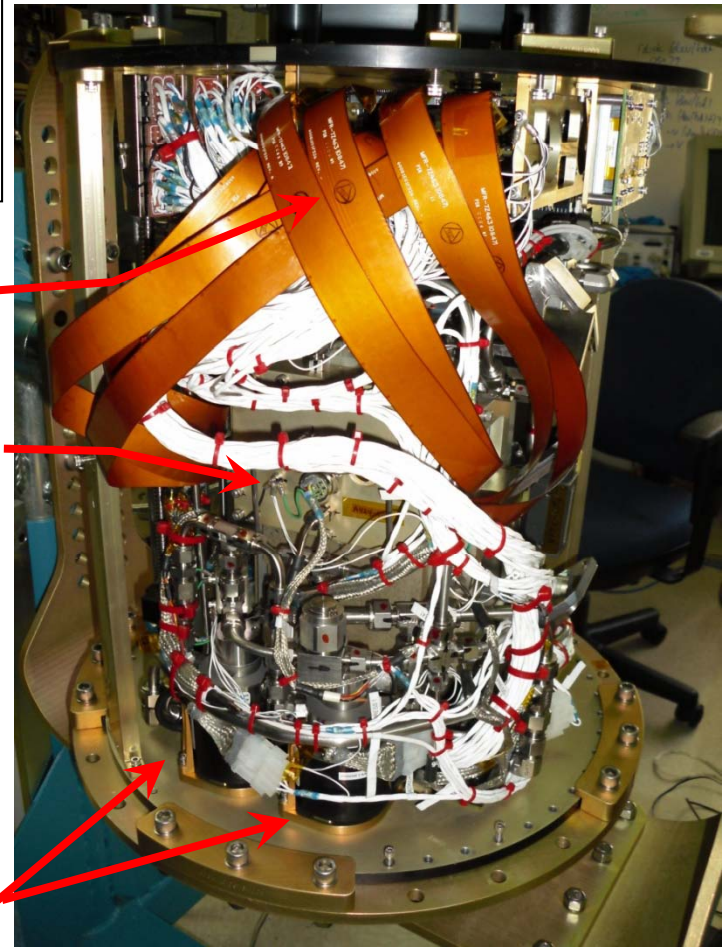



Glenn Research Center

# Test Chamber (top view)



Temperature Probes (6 places)

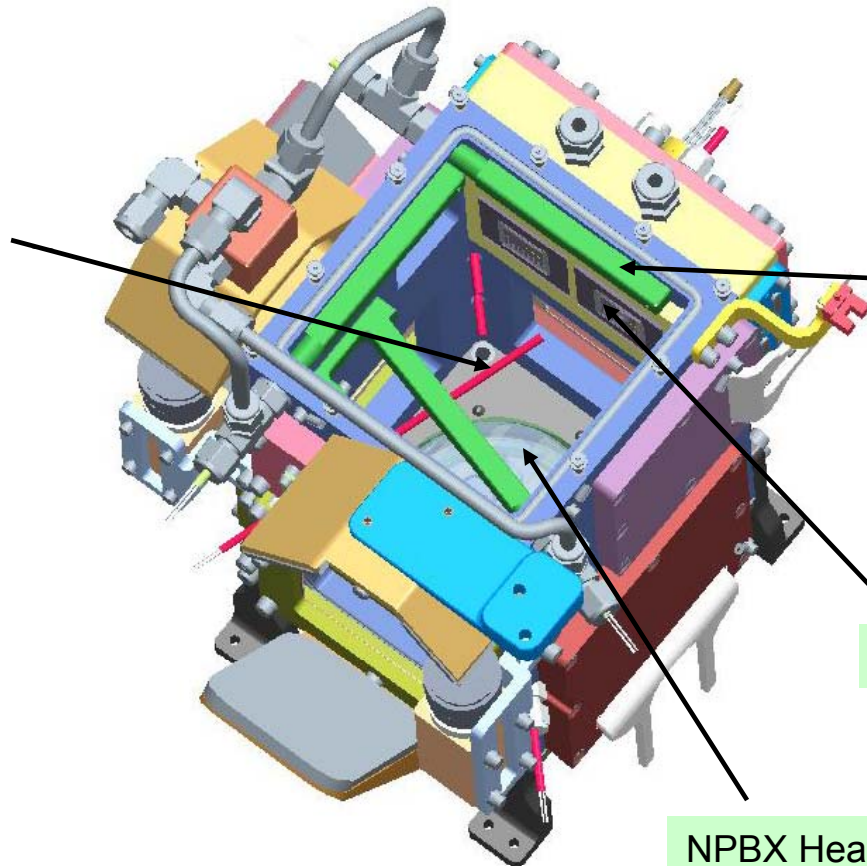

Bulk Fluid (Cartridge) Heater (3 places)

MABE Heater

NPBX Heater (bottom of TC)



Glenn Research Center

# BXF Fluids Schematic

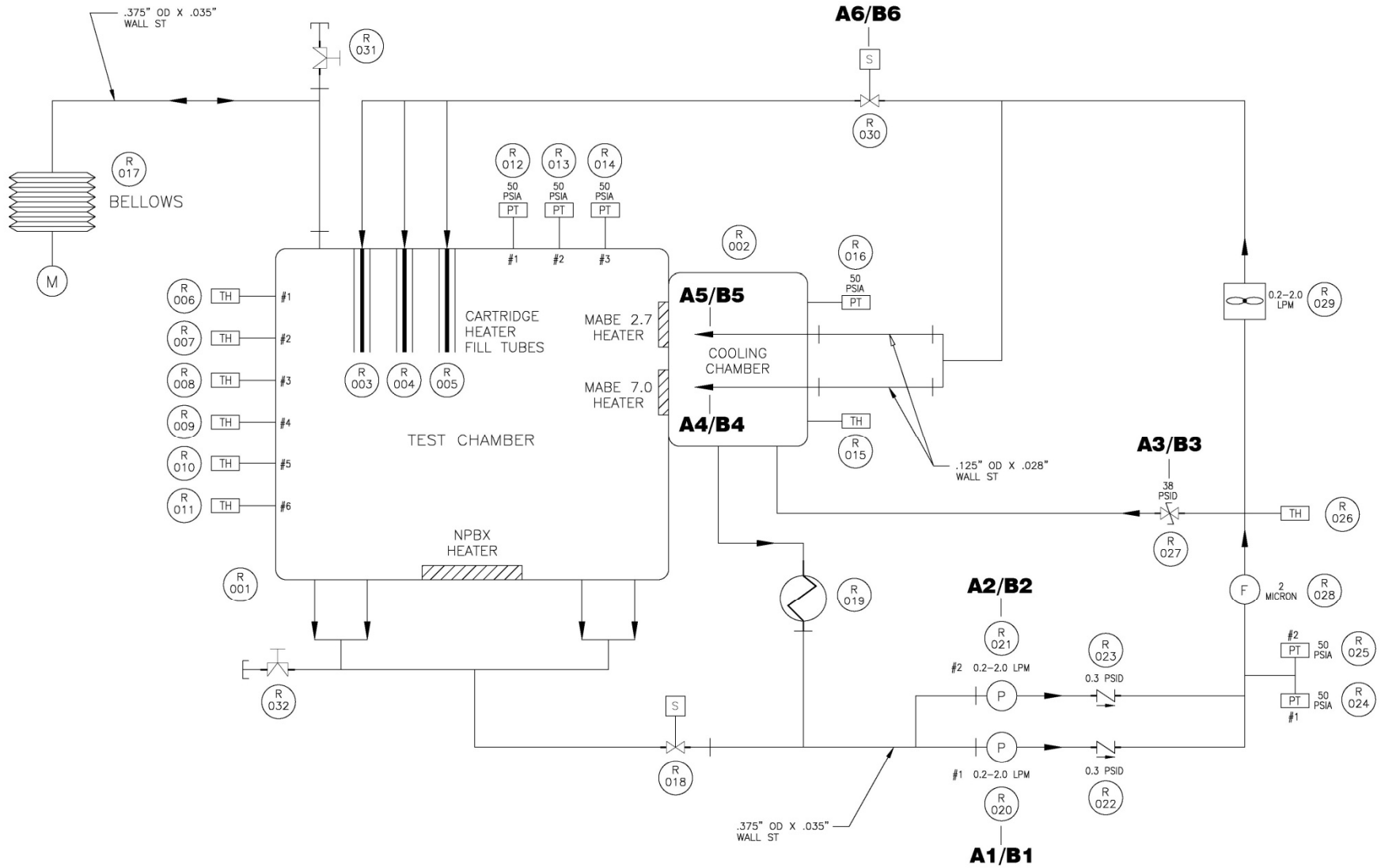

14 June 2012



Glenn Research Center

# Structural / Pressure System



## ➤ **BXF utilizes the Level of Containment (LOC) approach**

- Three (3) levels of containment required for Catastrophic Hazard potential
  - Test Chamber and associated plumbing
  - Double sealed Containment Vessel
- Each layer to be functionally separate, independent and verifiable
- Individual levels are not fracture critical
- Single-walled CV not considered a credible leak path (CLP)
- Plugs for compression-type fittings not considered a CLP
- Per JSC document ES4-02-050, in the LOC approach, no part/component is considered fracture-critical





# Safety Circuit



- If over temperature and/or overpressure occurs, power is removed from the BXF loads : bulk fluid heaters, NPBX Heater, cooling loop pumps, cooling loop solenoids, pressure control servo motor (bellows) and MABE Heaters.
- Two sets of sensors are used; Primary and Secondary Sets.
  - **Each Set Monitors:**
    - Test Chamber Bulk Fluid Temperature
    - Test Chamber Pressure
    - Cooling Loop Pressure
- Signals from each set of sensors go through comparator circuits and “AND” gates. The resulting signals along with the software input go through another “AND” gate.
- If one of the inputs is not within the acceptable range, safety shutdown will occur (fail safe): the signal (status) is latched, and the electronic switches (MOSFETs) shut off the positive and negative legs of the circuits feeding the load devices. A software input line on the safety circuit exists to shutdown the system in the event the software monitors an out of range condition for temperature or pressure.
- If safety shutdown happens, the system can be reset through the BXF Ops ground interface.
- BXF Software can not override BXF hardware safety controls if a sensor output is out of range.



Glenn Research Center

# Crew Involvement in Experiment Operations



- Configure MSG
  - Install and set BXF and the TSH into the MSG
- Camera Exchange
  - Re-configure High Speed Camera (i.e.: MABE 2.7 mm to MABE 7mm) by change-out of lens and relocation of camera. There are two fixed camera positions. The crew will not have to focus the lens. MSG will be powered down.
- Hard Drive and Video Tape exchanges
  - Change out hard drives and video tapes as required.
- Removal of hardware upon completion of BXF testing
  - Remove hardware from MSG and stow

Once installed and configured, BXF is operated from the ground via uplinked commands that either initiate a test run or data downlink

The BXF investigation planned no on-orbit maintenance



Glenn Research Center

# BXF ISS Operations and Anomalies Summary



- BXF was delivered to the ISS aboard ULF-5, which launched in February, 2011.
- Operations began on Tuesday March, 22.
- Week 1: Hardware setup, functional and video checkout, MABE and NPBX heater characterizations.
- Week 2 and Week 3: MABE and NPBX test point operations were conducted.
- On Monday, April 11, during MABE science operations, anomalous pressure readings tripped the BXF safety circuit, halting operations. Attempts to restart/reset/recycle BXF did not correct these readings and BXF was shut down.
- By this point MABE completed 260 of 540 tests. NPBX completed less than half of planned tests.



Glenn Research Center

# Anomaly: Data Plots



## 24V Bus 1 and 120V Current at time of anomaly

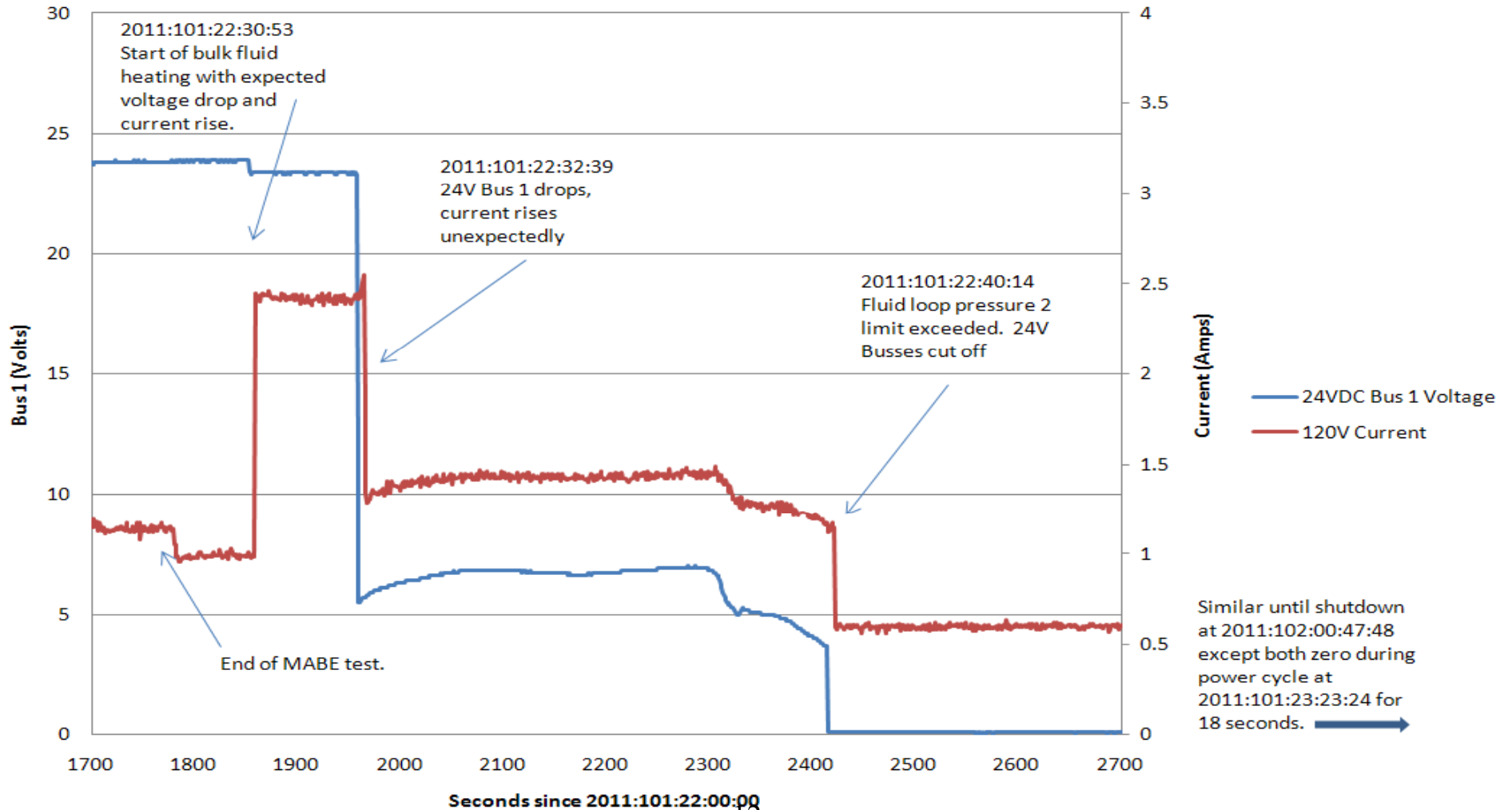

14 June 2012



Glenn Research Center

# Anomaly: Data Plots



### 24V Bus 1 and Pressures at time of anomaly

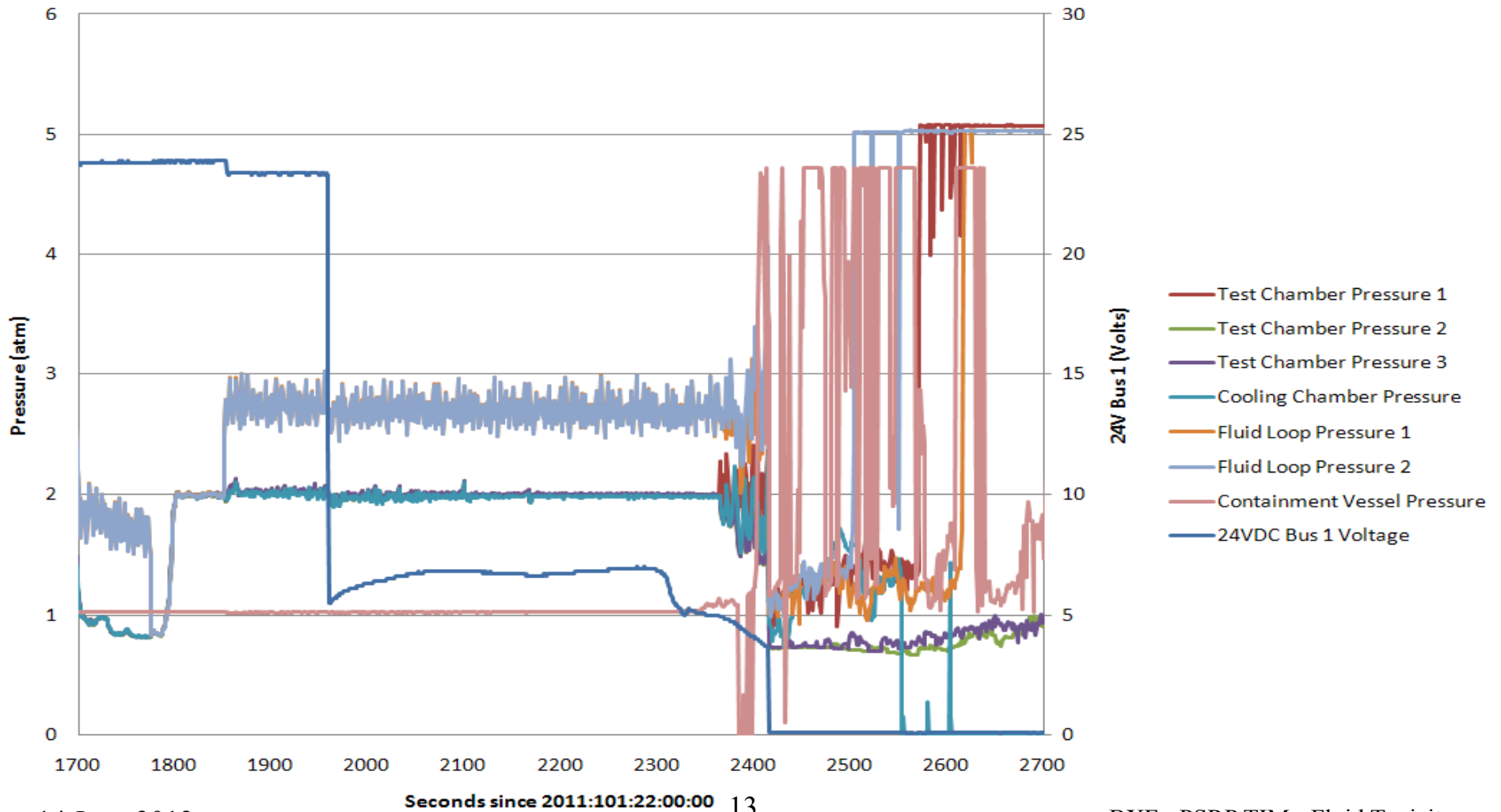

14 June 2012



Glenn Research Center

# Anomaly: Data Plots



## 24V Bus 1 and Temperatures at time of anomaly

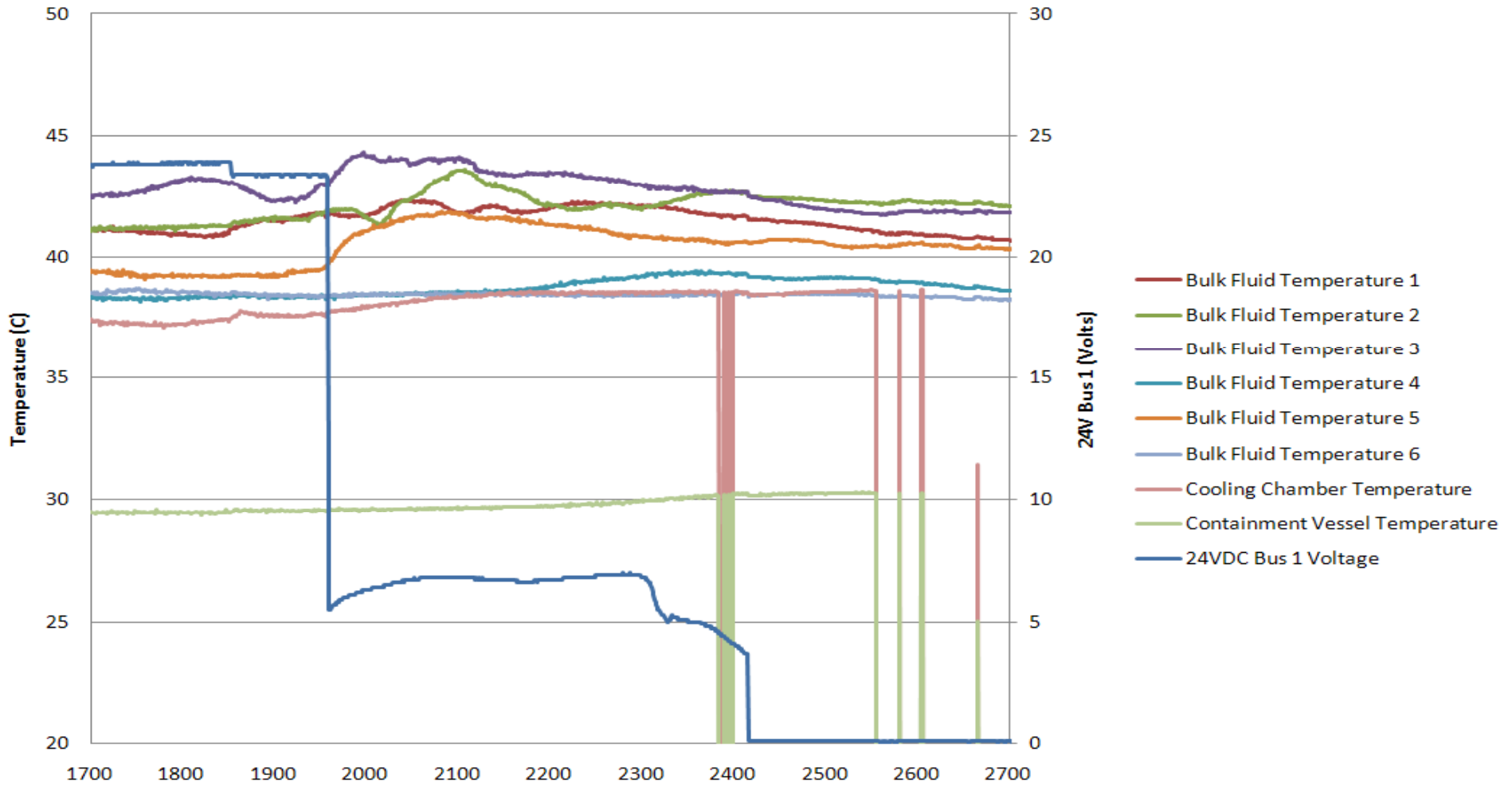

14 June 2012

Seconds since 2011:101:22:00:00 14

BXF - PSRP TIM - Fluid Toxicity



Glenn Research Center

# BXF ISS Operations and Anomalies Summary



- Tuesday, April 12 – Tuesday, April 19: The project team worked to understand the anomaly, identify troubleshooting activities and generate a troubleshooting plan.
- Thursday, April 21: A telecon was conducted with POIC Safety and the PSRP to discuss proposed troubleshooting.
  - Concerns/Questions:
    - BXF trouble shooting would not involve performing any new operations/commands
      - The only new operation involved in trouble shooting would be to remove power to either 24 VDC Bus 1 or 24 VDC Bus 2 to determine if there was a short on either bus
    - BXF would not violate any safety controls
      - Trouble shooting would not violate BXF safety controls
  - A draft of the Troubleshooting Flow Chart was provided
  - The OCR to conduct the troubleshooting was ultimately approved.



Glenn Research Center

# BXF ISS Operations and Anomalies Summary



- Monday, April 25: An Engineering Review Board was held to review the on-orbit troubleshooting plan.
- Wednesday, April 27: On-orbit troubleshooting was performed, controlled from the ground. Conclusions included:
  - Anything connected to the 24VDC Bus 1 could not be used.
  - Limited NPBX operations could still be performed with the 24 VDC Bus 1 switched off.
- Friday, April 29: Crew member inspects cable connections. Tornados shut down Huntsville operations.





Glenn Research Center

# BXF ISS Operations and Anomalies Summary



- Thursday, May 5: An ERB was held to review the procedures for continued science testing and to assess the risks involved.
- Monday, May 9 – Friday, May 13: Limited NPBX operations were performed.
- Friday, May 13: BXF was removed from MSG and stowed.
- All used video tapes and hard drives were returned on ULF-6.
- BXF was returned to KSC on ULF-7 in July, 2011.
- A Post Flight Assessment Review (PFAR) was kicked off in July, 2011.
- Starting at KSC and continuing at ZIN, BXF troubleshooting was performed according to plans and procedures assessed as part of the PFAR.



Glenn Research Center

## BXF PFAR Review Process



- There were four meetings to complete the entire PFAR process.
  1. BXF PFAR Kickoff - July 18, 2011
  2. BXF Troubleshooting Plan Approval - July 29, 2011
  3. BXF Troubleshooting Plan Execution Summary and Findings – March 8, 2012
  4. BXF PFAR Closeout – April 5, 2012



# Investigation Plan



- Post-Flight activities were conducted per the BXF Post Flight Assessment Anomaly Investigation Plan, PLAN-0383.
  - Prioritized Objectives (and the order in which they were completed):
    1. Verify the post-anomaly pressure and temperature measurement accuracies of the Flight system (2)\*
    2. Determine root cause of major ISS operations anomaly (4)
    3. Determine cause of high dissolved gas concentration measurements (3)\*
    4. Determine cause of camera alignment problem (1)\*
- \* These objectives and associated activities are not discussed in this presentation except as they may relate to the fluid toxicity issue.
- Plans did not include repair of the flight system once the root cause of the anomaly was identified as BXF will not be flown again.



# BXF Post Flight Assessment Anomaly Investigation Plan, PLAN-0383



Activities related to the fluid toxicity issue

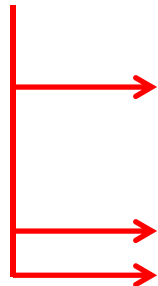

<b>3.0</b>	<b>INVESTIGATION</b> .....	<b>8</b>
3.1	EXTERIOR VISUAL INSPECTION AND PACKING AT KSC .....	8
3.2	UNPACKING AND EXTERIOR VISUAL INSPECTION AT ZIN .....	8
3.3	VOLTAGE BUS RESISTANCE CHECK .....	9
3.4	FUNCTIONAL CHECK .....	10
3.5	DISSOLVED GAS CONCENTRATION MEASUREMENT .....	11
3.6	HIGH SPEED CAMERA ALIGNMENT CHECK .....	11
3.7	24VDC BUS 1 ANOMALY CHECK .....	12
3.8	CONTAINMENT VESSEL GAS SAMPLING .....	13
3.9	CONTAINMENT VESSEL DISASSEMBLY: INSPECT INTERIOR AND INSTALL CV LEGS .....	14
3.10	24VDC BUS 1 COMPONENT RESISTANCE CHECK .....	15
3.11	PRE-DRAIN FLUID SAMPLING & ANALYSIS .....	15
3.12	FLIGHT HARDWARE DRAIN / FLUID DISPOSAL .....	16
3.13	PRESSURE AND TEMPERATURE MEASUREMENT ACCURACY CHECK .....	17
3.14	CONTAINMENT VESSEL DISASSEMBLY: UNINSTALL CV TOP PLATE / CV FAN VISUAL INSPECTION & TOUCH TEST .....	18
3.15	ROOM TEMPERATURE LEAK TEST .....	19
3.16	ELEVATED TEMPERATURE LEAK TEST .....	20
3.17	BXF EMBEDDED CONTROLLER INSPECTION AND BENCH TEST .....	20
<b>4.0</b>	<b>CONDITIONAL / OPTIONAL INVESTIGATION</b> .....	<b>21</b>
4.1	2.7MM MABE EMBEDDED CONTROLLER INSPECTION .....	21
4.2	7.0MM MABE EMBEDDED CONTROLLER INSPECTION .....	22
4.3	AVIONICS BOX OUTPUT VOLTAGE TEST .....	23
4.4	AVIONICS BOX INTERIOR VISUAL INSPECTION .....	23
4.5	BULK FLUID HEATER EXTRACTION AND INSPECTION .....	24
4.6	FOD ANALYSIS .....	25



## BXF "Toxicity" Issue



- The working fluid used by BXF is perfluoro-normal-hexane (PFNH); it has a Toxicity Rating of 0.
- The BXF Containment Vessel (CV) was designed with three Levels of Containment.
- One of the possible causes of the operational anomaly that was identified was that a bulk fluid heater shorted.
- It was suggested that if a Bulk Fluid Heater became excessively hot, the fluid could produce a potentially toxic byproduct, PFIB; this concern was raised with the PFAR Board at the PFAR Troubleshooting Plan Approval Meeting on July 29, 2011.
- Plans and procedures developed did not address handling/opening a system filled with a fluid that *may* contain a toxic byproduct.
- The project team needed to address this issue, particularly before opening the CV as part of troubleshooting activities; CV disassembly was scheduled to begin on 8/22/11.
- Steps were taken to determine if possibly contaminated fluid leaked from the fluids system (it didn't), to determine if the fluid was contaminated with PFIB (it was) and to mitigate against exposure to the PFIB.
- Ultimately, the fluids system was drained and containerized by ZIN and disposed of by a vendor arranged by GRC's Hazardous Waste Management organization. Representatives from Codes Q and D helped to assess the process and provided procedure review.
- Schedule impact > 3 months.



Glenn Research Center

# Containment Vessel Gas Sampling



- Plan Change: CV Gas Sampling added
  - Rationale: Test gas of CV Interior for perfluoroisobutene (PFIB) and perfluoro-normal-hexane (PFNH) due to growing concern that a Bulk Fluid Heater overheated and generated PFIB from the BXF Fluid
    - PFIB - hazardous gas, Acceptable exposure limits of 10 ppb TWA
- Two samples taken from CV Interior Space
- No HF or F<sub>2</sub> detected, indicative that PFIB not present
- Some PFMH detected, but at very low levels (334 & 437 ppm)
  - Attributable to low diffusion leakage
- Carbon byproducts detected, indicative of a combustion event

It was concluded that the BXF Test Chamber was intact (first level of containment still in place) and that it was okay to proceed with disassembly of the CV.



# Pre-Drain Fluid Sampling & Analysis



- Plan Change: Fluid Sampling & Analysis added
  - Rationale: Stronger evidence of an overheat condition, increasing concern that PFIB was produced.
- Two samples taken of BXF Fluid, 1 sample analyzed for PFIB
- **CONFIRMED!!!** 90 ppm of PFIB detected in BXF Fluid; Acceptable Exposure Level (AEL) is 10 ppb TWA
- CV reassembled to reestablish 3 levels of containment
- PFA Activities halted to determine how to proceed

Generation of PFIB in the fluid is indicative that the BXF Fluid (PFNH) was exposed to excessive temperatures long enough to cause molecular decomposition.  
14 June 2012

<sup>1</sup> EI Spec. #	<sup>2</sup> NICI Spec. #	<sup>3</sup> GC R.T.	Peak Assignment	M.W.	GC Area %
105	104	3.533	perfluoroethane	138	0.034
109	108	3.641	perfluoropropane	188	0.037
123	124	4.008	n-perfluorobutane	238	0.112
135	135	4.366	hexafluoropropene (HFP)	150	0.072
169	171	5.425	n-perfluoropentane	288	0.035
187	185	5.891	perfluoro-2-methylbutane (perfluoroisopentane)	288	0.050
<b>213</b>	<b>214</b>	<b>6.466</b>	<b>perfluoroisobutylene (PFIB)</b>	<b>200</b>	<b>0.009</b>
274-309	274-310	8.325	n-perfluorohexane (PFH)	338	98.482
314	323	8.675	perfluoro-2-methylpentane (perfluoroisohexane)	338	0.330
320	326	8.950	perfluoro-3-methylpentane	338	0.564
386	385	9.500	C <sub>7</sub> F <sub>12</sub> H <sub>2</sub> isomer, cyclic or olefin structure	314	0.012
398	397	10.000	C <sub>7</sub> F <sub>12</sub> H <sub>2</sub> isomer, cyclic or olefin structure	314	0.011
409	406	10.666	C <sub>7</sub> F <sub>12</sub> H <sub>2</sub> isomer, cyclic or olefin structure	314	0.023
419	419	10.975	C <sub>7</sub> F <sub>12</sub> H <sub>2</sub> isomer, cyclic or olefin structure	314	0.013
439	4438	12.100	C <sub>6</sub> F <sub>13</sub> H isomer	320	0.025
451	451	12.491	n-perfluorohexyl-1-hydride, CF <sub>2</sub> H-(CF <sub>2</sub> ) <sub>4</sub> -CF <sub>3</sub>	320	0.012
462	462	12.816	C <sub>6</sub> F <sub>10</sub> isomer, cyclic or olefin structure	262	0.102

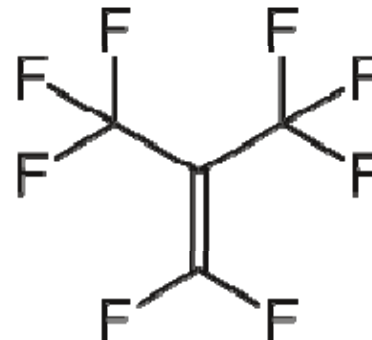



Glenn Research Center

# Flight Hardware Drain / Fluid Disposal



- Plan Change: Fluid Disposal added
  - Rationale: Dispose of the fluid due to discovery of hazardous PFIB
- Several courses of action considered
- Final Decision: NASA Hazardous Waste Management organization to arrange for disposal after safe transfer of fluid from BXF hardware to disposal cylinders
- During transfer process
  - Temperature and pressure measurements for better Dissolved Gas Concentration calculation
    - Result: 870 ppm
  - Collection of any foreign object debris (FOD) present in fluid





Glenn Research Center

# Bulk Fluid Heater: Extraction and Visual Inspection



- Bulk Fluid Heaters #2 & #3 (Cartridge Heater S/Ns 012 & 009, respectively)
  - Discolored and blackened
  - Heater #2 more blackened than Heater #3
  - Aside from discoloration, no other damage observed
- Bulk Fluid Heater #1 (Cartridge Heater S/N 010)
  - Unable to extract through port fitting, so entire port fitting removed to extract heater
  - Extreme damage in two locations on heater sheath
  - Incoloy 800 melted in both locations
  - Brownish Magnesium Oxide and greenish Nickel-Chromium wiring visible

The damage of Bulk Fluid Heater #1 proves excessive temperatures were achieved on-orbit.

Heater Material	Melting Point (°C)
Incoloy 800	1385
Magnesium Oxide	2800
Ni-Cr Wire	1400



Glenn Research Center

# Bulk Fluid Heater: Extraction and Visual Inspection



Heater #2

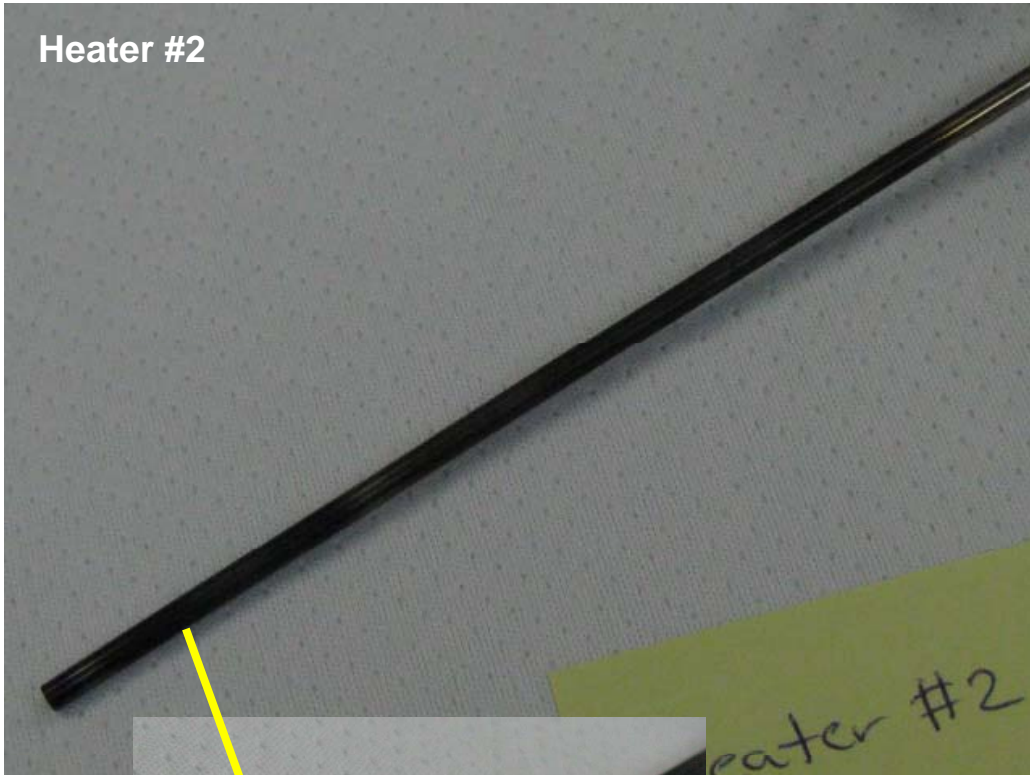

Heater #3  
Tip Detail



14 June 2012

Heater #2  
Tip Detail

Heater #2

26

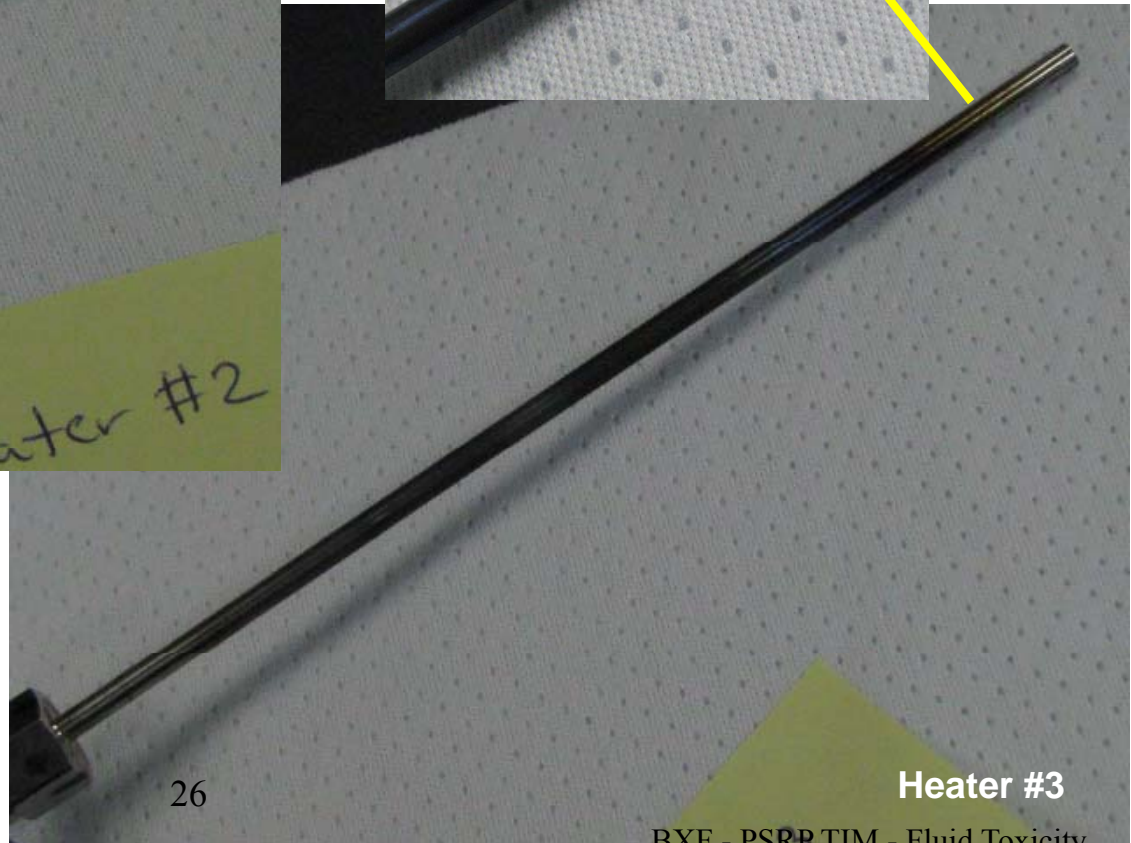

Heater #3



Glenn Research Center

# Bulk Fluid Heater: Extraction and Visual Inspection

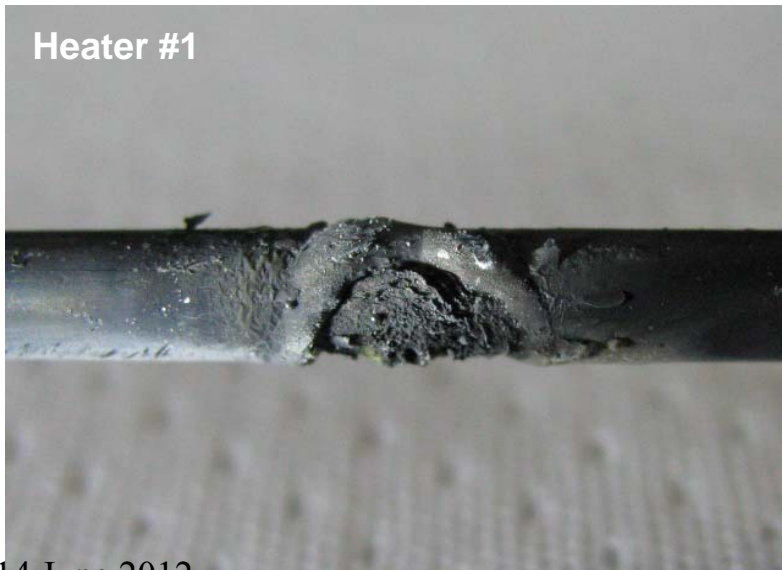



Glenn Research Center

# Bulk Fluid Heater: Extraction and Visual Inspection



## Top View of Experiment Chamber (Looking Down)

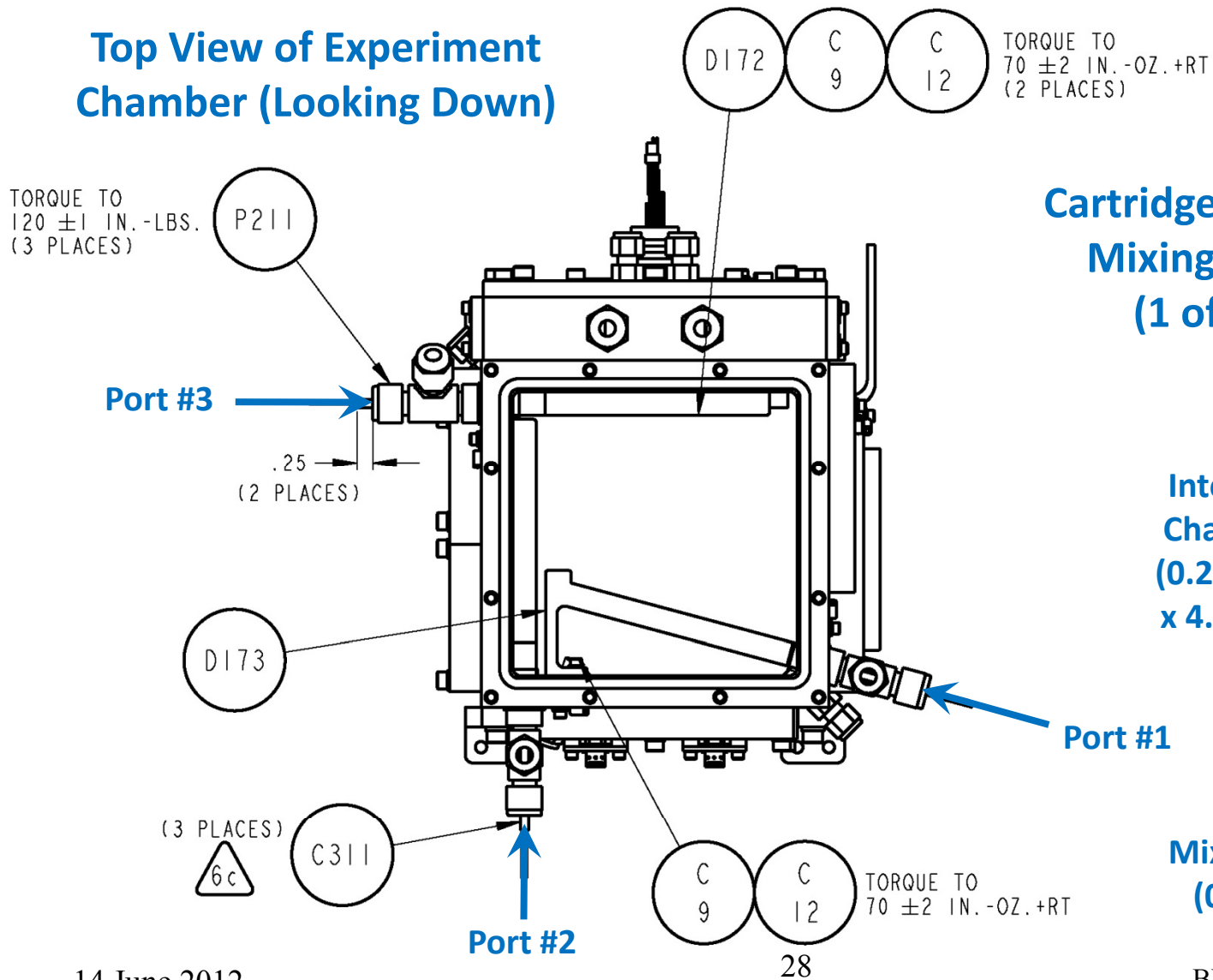

## Fluid and Heater Entry

### Cartridge Heater Mixing Duct (1 of 3)

Interior Channel (0.25 DIA x 4.0 LG)

Port #1

Mixing Jet Exit (0.100 DIA)

14 June 2012

BXF - PSRP TIM - Fluid Toxicity



Glenn Research Center

# Bulk Fluid Heater: Extraction and Visual Inspection



- Heater Operating Conditions
  - 60 W @ 24 VDC, 1/8" DIA x 6" LG, 1/4" No Heat Zone
  - Heat Flux  $\approx 4 \text{ W/cm}^2$
  - $\sim 0.04 \text{ L/min}$ . flow over each heater at time of anomaly
- Fluid manufacturer 3M recommends heat flux of no more than 6-10 W/cm<sup>2</sup>
  - If exceed, “boiling is no longer stable, a vapor blanket forms on the wire, and the wire temperature skyrockets.”
  - This is called exceeding the “critical heat flux,” and it leads to burnout of heating element.

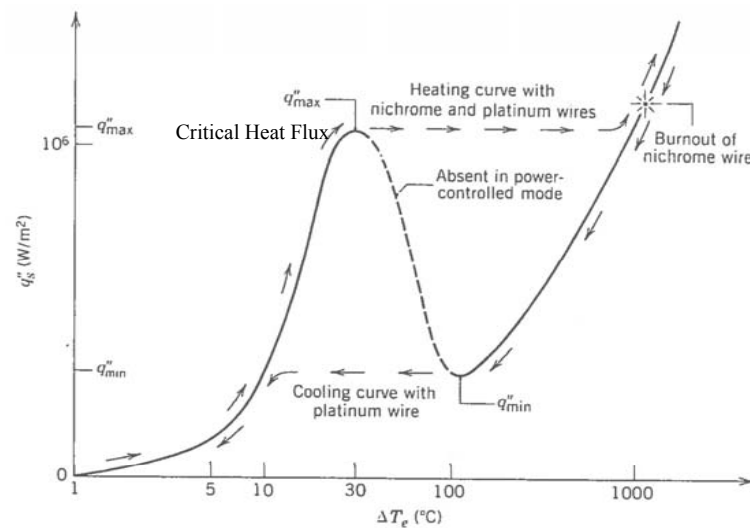

Figure 10.3 Nukiyama's boiling curve for saturated water.

Typical boiling curve with onset to “burnout point” or “boiling crisis”



# Bulk Fluid Heater: Extraction and Visual Inspection



- Heater manufacturer Watlow examined discoloration and damage of heaters
  - “All signs of failures appear to be from exposure to high temperature.”
  - Heater #1: “Melting of sheath (insulation breakdown due to high temperature causing an arc...)”
  - Heater #2: “Discoloration and oxidation with a shorted internal winding due to high temperature.”
  - Possible causes: “Watt density too high” and “Material flow issues - low flow, no flow, or pattern of flow not taking heat away.”
  - Recommendation: “Suggest you monitor the heater temperature and use a high-limit controller to shut the heater down to avoid overtemperature.”

Typical boiling curve with critical heat flux and boiling types

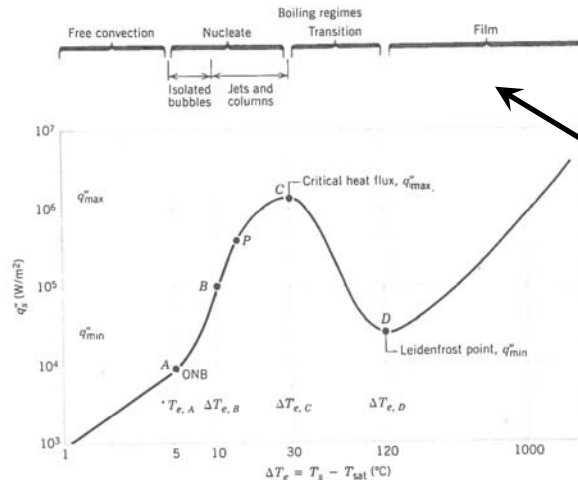

Figure 10.4 Typical boiling curve for water at one atmosphere: surface heat flux  $q''_s$  as a function of excess temperature,  $\Delta T \equiv T_s - T_{sat}$ .

Film boiling completely blankets surface, insulating it and allowing only radiative loss of heat.

Result: Surface temperature jumps enormously with little additional heat input.



Glenn Research Center

# Bulk Fluid Heater: Post-Extraction Resistance Check



- Bulk Fluid Heaters 2 & 3 (Cartridge Heater S/Ns 012 & 009, respectively)
  - Results similar to those produced during 24VDC Bus 1 Component Resistance Check
  - Partial Shorts on Heater 2 to heater sheath, but not the wiring shield
  - Heater 3 passed
- Bulk Fluid Heater 1 ( Cartridge Heater S/N 010)
  - Erratic results, resistance values not stable
  - Still evident in data that Heater 1 is bad



# Bulk Fluid Heater: Heater Wiring Dissection



- Bulk Fluid Heater 2 (Cartridge Heater S/N 012)
  - Observations nominal throughout all stages of dissection
  - Heater resistance  $\approx 9.63 \Omega$  during dissection
  - Partial shorts to heater sheath found:  $\approx 40 \text{ k}\Omega$ , consistent with prior investigation results
- Bulk Fluid Heater 1 (Cartridge Heater S/N 010)
  - Shield fused to inner insulation sleeving at connector, could not pull shield back from connector
  - Shield hardened, very tough and difficult to cut open
  - Inner insulation sleeving carbonized near connector, crumbled apart
  - Internal wire insulation blackened overall, but whitened over crimped area; Exposed wire near connector.
  - Connector melted, contacts completely encased, unable to extract
  - Wiring separated from heater on its own (no cutting needed)
  - Heater sheath bent at weakened damaged area due to handling
  - Heater Resistance not stable, varied greatly during dissection
  - Heater Resistance at heater sheath =  $7.08 \Omega$ , stable
  - Shorts found to heater sheath  $\approx 8 \Omega$
  - Wiring failed continuity measurements







Glenn Research Center

# Applicable BXF Unique Hazard Reports



- BXF-01, Rupture/Leakage of the BXF Pressurized System:
  - DESCRIPTION OF HAZARD: Rupture of the BXF pressurized containment system leading to MSG damage (catastrophic), and test fluid leak with the potential impact on the ISS ECLSS (critical).
  - Applicable HAZARD CAUSES:
    - 6. BXF seal failure creates a leak path.
    - 7. Run-away BXF science and/or BXF bulk fluid heaters lead to test chamber over-pressure.
  - HAZARD CONTROLS:
    - 6. The BXF seals are designed to maintain containment.
    - 7.1 Proper design of bulk fluid temperature control system, which includes the redundant temperature sensors connected to BXF Shutdown Circuit to shut the experiment down if bulk fluid temperature exceeds 68C. BXF Shutdown Circuit includes an inhibit in the ground/return leg.
    - 7.2 Proper design of bulk fluid pressure control system, which includes redundant transducers connected to BXF Shutdown Circuit to shut the experiment down if bulk fluid pressure exceeds 3.25 atm. BXF Shutdown Circuit includes an inhibit in the ground/return leg.
    - 7.3 Proper software version is installed, which shuts the experiment down if bulk fluid temperature exceeds 66C and/or bulk fluid pressure exceeds 3.1 atm.



Glenn Research Center

# Applicable BXF Unique Hazard Reports



- BXF-01, Rupture/Leakage of the BXF Pressurized System:
  - Key Points:
    - The BXF CV maintained three levels of containment of the test fluid and decomposition products during and after the operations anomaly.
    - The Safety Circuit initially tripped when a system pressure reading exceeded its limit. Erratic pressure readings at the time of the anomaly and immediately afterwards are not deemed to be entirely credible. It is believed that a complex interaction between the shorted cartridge heater and the electronics inside the Containment Vessel (CV) is the cause of these readings.
    - Bulk fluid temperatures did not rise significantly at the time of the anomaly and remained within limits of the Safety Circuit; the overheating that occurred was a localized.
    - The Safety Circuit functioned properly and did not allow reset while the erratic, out of limit pressure readings persisted.



Glenn Research Center

# Applicable BXF Unique Hazard Reports



- BXF-05, Use of Materials with Potential to Form Hazardous Pyrolysis Products in Habitable Environment:
  - DESCRIPTION OF HAZARD: Contamination of the ISS, injury/illness to the crew
  - HAZARD CAUSES: Use of Perfluorohexane-based fluid of insufficient quality containing isomers that can form potentially hazardous pyrolysis products when in contact with the heated surfaces (such as the ISS TCCS) if fluid leakage occurs.  
(Note: Rupture/Leak of the BXF Pressurized System is covered by the Unique Hazard Report BXF-01)
  - HAZARD CONTROLS: Use of non-toxic fluid, which does not contain undesirable impurities (isomers) to produce the potentially hazardous pyrolysis products.
  - Key Point: The temperatures that the fluid was exposed to during the course of the anomaly were much higher than previously deemed credible.



# On-Orbit Anomaly Conclusions



It can be concluded from the investigation results that Cartridge Heater S/N 010 (Bulk Fluid Heater 1) overheated. The heater temperature had to have reached at least 1400°C in order to melt the Incoloy 800 and NiCr materials of the heater. The heat that was generated probably transferred via thermal conduction down the cartridge heater wiring causing the burn and melt damage observed near the connector. The burning and melting of the heater and its wiring led to the creation of an electrical short on 24VDC Bus 1. This short would have caused the 24VDC Bus 1 DC/DC converter to go into current limiting mode, reducing voltage output, while at the same time, causing higher than nominal current draw from MSG.

The investigation results also suggest that Cartridge Heater S/Ns 012 and 009 (Bulk Fluid Heaters 2 and 3, respectively) may have also overheated, or came close to doing so.

The manufacturers of the cartridge heaters and BXF Fluid (PFNH) were consulted to determine the possible reasons why the heaters overheated. Reference the information located in Appendix B and Appendix C. The following is a list of the most likely causes.

- Lack of direct heater temperature monitoring and control allowed overheating to occur.
- The dissipation heat flux of the heaters was close to the normal gravity critical heat flux of the fluid (4 W/cm<sup>2</sup> vs. 6-10 W/cm<sup>2</sup>).
- Fluid flow rate may have been too low to carry heat away from the heaters.
- Microgravity may have inhibited convective removal of heat from the heaters.

One or more of the factors above contributed to a scenario in which nucleation boiling of the fluid may have been induced around the heaters. In the case of Heater 1, this nucleation boiling may have progressed to film boiling, causing the heater to become completely enveloped in vapor. The vapor, in turn, would have acted as a thermal insulator and significantly reduced heat transfer from the heater to the fluid. This would have caused the heater to enter into a “runaway” condition in which the heater temperature increases extremely rapidly. The Bulk Fluid temperature sensors throughout the Test Chamber would not have detected this local temperature rise at the heater.



# BXF Lesson Learned



**Title/Subject:**

**ISS Operations Anomaly**

**Abstract:**

During operations on-board the ISS, the BXF experienced an anomaly that required a system shutdown. A work around to the anomaly was developed and operations continued at a reduced capability. The BXF system was returned to the ground for post flight assessment and troubleshooting. Analysis of a sample of the BXF fluid perfluoro-normal-hexane (PFNH) determined some of it decomposed due to exposure to very high temperatures creating the hazardous substance perfluoroisobutylene (PFIB). Testing and inspections determined the root cause to be excessive over heating of a Bulk Fluid Heater submersed in the fluid. The overheating was brought about by exceeding the critical heat flux of the heater.

**Driving Event:**

On April 11, 2011 (GMT 2011/101), the voltage on 24VDC Bus 1 dropped unexpectedly to about 6V, and an off-nominal current was drawn from MSG. This condition went unnoticed for approximately 8 minutes at which point a fluid loop pressure warning occurred. The BXF system entered into safe mode and tripped the safety circuit to remove power from the heaters and motors. It was observed that all pressure readings and some temperature readings were off-nominal. Attempts were made to recover by resetting the embedded controllers (ECs), restarting the BXF software, and cycling power to BXF. All attempts failed. The system was shutdown.



# BXF Lesson Learned



## Lesson Learned:

There are multiple lessons learned for this driving event:

1. Extreme localized heating can occur without impacting the bulk fluid temperature of a fluid system.
2. Design electrical system so failed components can be isolated in order to maintain maximum capabilities in the event of a failure.
3. Experiment designs and test fluids must be thoroughly understood and all hazard scenarios and failure modes investigated in order to prevent unintended consequences during a failure.
4. Coordination between mechanical, thermal and electrical engineering is necessary to ensure that the power supply does not exceed some safe heat flux limit.

## Recommendation:

1. Measure heater temperatures directly and incorporate into control/protection circuit.
2. Individually fuse heaters and use independent controls to activate/deactivate them.
3. Better review of critical designs is required to ensure they function as intended and that appropriate hazard controls are included.
4. De-rate heaters (and other convective heat devices) from normal to microgravity operation.



Glenn Research Center

## BXF Project Status



- All BXF post-flight assessment activities have been completed and documentation baselined. Main documents:
  - BXF Post-Flight Assessment Investigation Report, 60081-RPT-0402
  - Lessons Learned Report, 60081-RPT-0403 → Documents 49 Lessons Learned in the disciplines of Engineering, Manufacturing, Safety & Mission Assurance, Science, Operations and Management.
  - Mission Summary Report, 60081-RPT-0404
- The BXF PFAR was completed on April 5, 2012. The only go forward action was to conduct a TIM with the PSRP to discuss the fluid toxicity issue.
- BXF will not be flown again and all engineering activities have been concluded.
- Lessons learned will be shared with the larger GRC community beginning with the Program Review Board and through the NASA lessons learned database as appropriate; specifically, lessons learned will be applied by projects using fluids in the same family with similar concerns about heater dry-out and/or fluid toxicity.



Glenn Research Center

# Fluid Toxicity – Relevance to Other Payloads in Development



- The subject of fluid toxicity and the potential to create hazardous decomposition byproducts is relevant to other payloads that are in development and are using similar fluids.
- GRC Payloads:
  - **Zero Boil-Off Tank (ZBOT) Experiment:**

Description: A small-scale simulant-fluid ISS flight experiment to study storage tank pressurization (through heating) & pressure reduction through fluid mixing in microgravity; utilizes perfluoro-n-pentane (PnP), which has been rated as Tox 0 / Flam 0 by JSC Toxicology.

Status: Engineering Model (EM) hardware has been developed and the project is working towards a Phase 0/1/2 Flight Safety Review in July/August 2012, and Critical Design Review in September 2012.
  - **Flow Boiling and Condensation Experiment (FBCE):**

Objective: To develop an experimentally validated, gravity independent, mechanistic model for microgravity annular flow condensation and microgravity flow boiling critical heat flux. The test fluid planned is currently perfluoro-normal-hexane (C6F14).

Status: The experiment is in the requirements definition and engineering concept formulation stage. An Informal Design Review is scheduled for Dec 2012 and the Requirement Definition Review is scheduled for September 2013.





Glenn Research Center

# Fluid Toxicity – Relevance to Other Payloads in Development



- JAXA is planning a flow boiling experiment using a perfluorohexane fluid. The experiment is still in the definition stages.
- ESA is planning several phase change experiments for their Thermal Platform in the Fluids Science Laboratory in the Columbus module. Several fluids are under consideration and are tailored to the type of experiment. It is believed that these experiments are in the preliminary design stages.
- Note: The JAXA and ESA payloads are not managed by GRC and the information presented is not directly provided by the Payload Developers.



Glenn Research Center



## Backup Charts



# BXF Capabilities



- Test fluid perfluoro-normal-hexane (PFNH); Tox 0.
- Bulk Liquid Temperature
  - Range: 30 - 60°C
- Test Chamber Pressure
  - Range 0.6–2.6 atm
- Video at Fixed Positions
  - NPBX Heater – 2 Side Views of NTSC video at 30 frames per second (fps)
    - 70 mm x 72 mm FOV
  - MABE Heater Arrays –
    - 1 Side View of NTSC video at 30 fps, 40 mm x 40 mm FOV
    - Bottom View (HSC) up to 500 fps, 512 x 512 resolution, 2000 Frame Acquisition
      - Small array, 2.7 mm heater- 4 mm x 4 mm FOV
      - Large array, 7 mm heater - 10 mm x 10 mm FOV
- Data Storage
  - Removable 120 GByte Hard Drives
  - Video Tapes (Analog & Digital)



Glenn Research Center

# BXF Electrical Design Safety

(Presented at the NPBX Science Testing ERB, May 5, 2011)



- Circuit Protection consists of DC/DC converters/regulators (equipped with active shutdown circuitry), circuit breakers, and fuses.
- MSG has current limiting at 10A on the 120V
- A short circuit would cause the DC/DC converter/linear regulator to current limit before the respective fuse opens
- Upstream inhibit in the primary power connector (120 V)
- Max short current of NPBX heater is 10A, max operating current 100% duty cycle is 1.28 A
- Wire sizes selected such that the operating temperature limit for wire insulation will not be exceeded (200 °C wire de-rating values used)
- BXF hardware passed integrated bonding test with MSG
- BXF hardware is grounded inside MSG
- BXF fluid, perflouro-normal-hexane , is rated 0 for tox and flammability. In the event of an “overrun” condition by the NPBX heater, the fluid and heater are contained and inaccessible to the crew



Glenn Research Center

# Project Correspondence with the Cartridge Heater Manufacturer



Kevin,

The first thought of the temperature sensor was to have it imbedded internally within the heater. There are 3 types/locations, A, B, and C.

Type A is in the middle of the heater core and used to monitor the internal temperature of the heater. It is the best to monitor to maintain heater life and avoid it burning up.

Type B is located anywhere along the heater. It has a section of no-heat and is best used to actually monitor the part temperature that the heater is in contact with.

Type C is in the end of the heater on the opposite end of the lead wires. It is the best to monitor temperatures in applications where material flows past the end of the heater.

Since your heater is 1/8", the only type available is C. The 1/4" and larger heaters permit all types A, B, & C to be used.

The hottest part of a heater left in air will be the middle. Unless you can use a type C (on the end) and correlate the temperature of the middle section, that leaves a surface mount sensor as the only option. Watlow makes a hose clamp style thermocouple, but unfortunately, not as small as 1/8". You would have to fabricate one yourself.

I would think that a standard 301 type thermocouple wire (20AWG w/fiberglass insulation good to 2200F) clamped onto the center of the heater would be best. However, by looking at the drawings, I don't think the space permits that.

The Experiment Chamber drawing seems to show a tight fit between the heater and the bored hole, but I'm not sure how Heater #1 could have blown apart if it was tightly nestled in a hole. Heaters #2 & #3 may not have burned up due to having a tighter hole and being able to transfer the heat more efficiently away from the heater.

After explaining all this to you and looking at everything, unfortunately I'm not quite sure how to fix the problem without redesigning the chamber to accommodate a thermocouple somehow.

At least now you know the options.

Hope this helps.

Thanks,

Nick



# Acronyms & Abbreviations



<b>A</b>	<b>Amps</b>	<b>LG</b>	<b>Length</b>
<b>AB</b>	<b>Avionics Box</b>	<b>LOC</b>	<b>Level of Containment</b>
<b>AEL</b>	<b>Acceptable Exposure Limit</b>	<b>MABE</b>	<b>Micro Heater Array Boiling Experiment</b>
<b>atm</b>	<b>Atmosphere</b>	<b>MOSFET</b>	<b>Metal Oxide Semiconductor Field-effect Transistor</b>
<b>AWG</b>	<b>American Wire Gage</b>	<b>MSG</b>	<b>Microgravity Science Glovebox</b>
<b>BXF</b>	<b>Boiling Experiment Facility</b>	<b>Ni-Cr</b>	<b>Nickel Chromium</b>
<b>C</b>	<b>Celsius</b>	<b>NPBX</b>	<b>Nucleate Pool Boiling Experiment</b>
<b>CLP</b>	<b>Credible Leak Path</b>	<b>OCR</b>	<b>Operations Change Review</b>
<b>cm</b>	<b>centimeter</b>	<b>ODIN</b>	<b>Orbital Design Integration System</b>
<b>CV</b>	<b>Containment Vessel</b>	<b>Ops</b>	<b>Operations</b>
<b>DIA</b>	<b>Diameter</b>	<b>PFA</b>	<b>Post Flight Assessment</b>
<b>EC</b>	<b>Embedded Controller</b>	<b>PFA</b>	<b>Post Flight Assessment Review</b>
<b>E-Net</b>	<b>Ethernet</b>	<b>PFIB</b>	<b>Perfluoroisobutylene</b>
<b>ESA</b>	<b>European Space Agency</b>	<b>PFNH</b>	<b>Perflouro Normal Hexane</b>
<b>F<sub>2</sub></b>	<b>Fluorine</b>	<b>PI</b>	<b>Principal Investigator</b>
<b>FOD</b>	<b>Foreign Object Debris</b>	<b>ppb</b>	<b>Parts per billion</b>
<b>FOV</b>	<b>Field of View</b>	<b>ppm</b>	<b>Parts per million</b>
<b>fps</b>	<b>Frames per second</b>	<b>POIC</b>	<b>Payload Operations Integration Center</b>
<b>Gbytes</b>	<b>GigaBytes</b>	<b>PSRP</b>	<b>Payload Safety Review Panel</b>
<b>GRC</b>	<b>NASA Glenn Research Center</b>	<b>S/N</b>	<b>Serial Number</b>
<b>GMT</b>	<b>Greenich Mean Time</b>	<b>TC</b>	<b>Test Chamber</b>
<b>HSC</b>	<b>High Speed Camera</b>	<b>TCCS</b>	<b>Trace Contaminant Control System</b>
<b>HF</b>	<b>Hydrogen Fluoride</b>	<b>TIM</b>	<b>Technical Interchange Meeting</b>
<b>ISS</b>	<b>International Space Station</b>	<b>TSH</b>	<b>Triaxial Sensor Head</b>
<b>JAXA</b>	<b>Japanese Space Agency</b>	<b>TWA</b>	<b>Time Weighted Average</b>
<b>JSC</b>	<b>NASA Johnson Space Center</b>	<b>ULF</b>	<b>Utilization Flight</b>
<b>KSC</b>	<b>NASA Kennedy Space Center</b>	<b>VDC</b>	<b>Volts Direct Current</b>
<b>L</b>	<b>liters</b>	<b>W</b>	<b>Watts</b>