

Stress Analysis and Testing at the Marshall Space Flight Center to Study Cause and Corrective Action of Space Shuttle External Tank Stringer Failures

Robert J. Wingate*

NASA Marshall Space Flight Center, Huntsville, AL

After the launch scrub of Space Shuttle mission STS-133 on November 5, 2010, large cracks were discovered in two of the External Tank intertank stringers. The NASA Marshall Space Flight Center, as managing center for the External Tank Project, coordinated the ensuing failure investigation and repair activities with several organizations, including the manufacturer, Lockheed Martin. To support the investigation, the Marshall Space Flight Center formed an ad-hoc stress analysis team to complement the efforts of Lockheed Martin. The team undertook six major efforts to analyze or test the structural behavior of the stringers. Extensive finite element modeling was performed to characterize the local stresses in the stringers near the region of failure. Data from a full-scale tanking test and from several subcomponent static load tests were used to confirm the analytical conclusions. The analysis and test activities of the team are summarized. The root cause of the stringer failures and the flight readiness rationale for the repairs that were implemented are discussed.

I. Introduction

On November 5, 2010, the launch of Space Shuttle mission STS-133 was scrubbed after propellant loading due to a gaseous hydrogen leak at the ground umbilical connection to the External Tank (ET). During visual inspections following the scrub, a large crack in the ET sprayed-on foam insulation (SOFI) was observed at the forward end of the intertank near the interface to the liquid oxygen (LOX) tank (Figure 1). Cracks in the foam were not typical in this region and violated a launch constraint due to debris concerns, necessitating a foam repair before any future launch attempt.

Removal of the damaged foam revealed that an underlying aluminum hat-section stringer had cracked approximately 9 inches along each side, just inboard of the fasteners that attached the stringer “feet” to the intertank forward flange chord (Figure 2). The crack in the foam was solely a result of the stringer failure. An adjacent stringer was also found to be similarly cracked on each side for about 3 inches along its forward end, although the SOFI directly over it had appeared undamaged.

This event is thought to be the first known in-service failure of ET metallic structure in the more than 30-year history of the ET project. The NASA Marshall Space Flight Center (MSFC), as managing center for the ET Project, coordinated the ensuing failure investigation and repair activities with multiple organizations, including the ET prime contractor (Lockheed Martin Space Systems – Michoud Operations), the Space Shuttle Program Office at the NASA Johnson Space Center (JSC), the NASA Kennedy Space Center (KSC), and the NASA Engineering and Safety Center (NESC). As part of the cause and corrective action assessments, several structural analyses and static load tests of stringers were conducted by the engineering organizations at the MSFC to complement the efforts of Lockheed Martin. The objective of this paper is to provide a synopsis of the failure investigation and development of flight readiness rationale from the perspective of the MSFC stress analysis team.

II. Background

The Space Shuttle ET contains and delivers the liquid hydrogen (LH2) and LOX propellants for the Orbiter’s three main engines. It also serves as the structural backbone of the Space Transportation System, providing for

* Aerospace Engineer and Team Lead, AIAA Senior Member.

attachment of the Orbiter and the Solid Rocket Boosters (SRBs) [1]. The ET is comprised of three primary structural elements: an aft LH2 tank and a forward LOX tank separated by an intertank (Figure 3).

The intertank is an unpressurized, stiffened cylindrical structure that serves as the structural connection between the two propellant tanks and also functions to receive and distribute all thrust loads from the SRBs. It is an assembly of eight curved panels that are mechanically joined into a barrel with five internal ring frames. The SRBs attach to a box beam that extends across the diameter of the intertank at the middle ring. The two intertank panels located at each end of the SRB beam react a majority of the SRB thrust loads and are manufactured from thick plate as one-piece panels with integrally machined blade stiffeners and pocketed membrane areas. The other six intertank panels are skin/stringer panels manufactured from sheet metal skins and externally-mounted, hat-section stringer stiffeners (Figure 4). The stringers are mechanically attached with rivets along most of their length and with specialty fasteners, such as GP Lockbolts and Hi-Loks, at the forward and aft ends where the stringers attach to flange chords (Figure 5). The chords at the forward and aft ends of the stringer panels are extruded, stretch-formed aluminum angle-section that provide a mating flange for mechanically fastening the intertank to the ring frames of the adjacent propellant tanks. The hat-section stringers are fabricated from aluminum sheet with a combination of rolling and hot-forming processes. There are 18 stringers per panel, located on approximately 7-inch centers.

Over the course of the project history, there have been two major revisions of the ET design to decrease structural weight. The general structural configuration of the intertank remained unchanged throughout those changes; however, the last major evolution from Lightweight Tank (LWT) to the Super Lightweight Tank (SLWT) involved a widespread change of skin/stringer material from aluminum alloy Al-2024 to aluminum-lithium alloy Al-2090 [2]. The ET used with STS-133 (serial number ET-137) was the forty-second SLWT manufactured. All ETs were manufactured by Lockheed Martin (formerly Martin Marietta) at the NASA Michoud Assembly Facility (MAF) in New Orleans, LA.

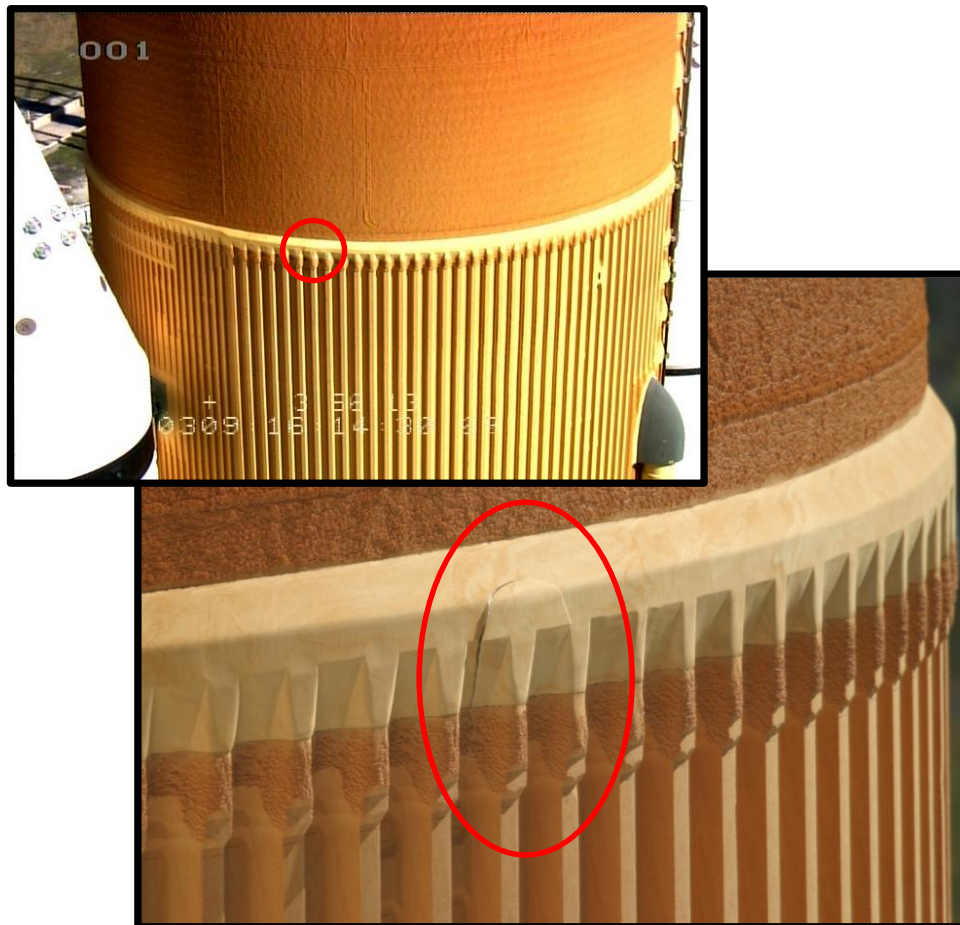

Figure 1. SOFI crack after STS-133 launch scrub.

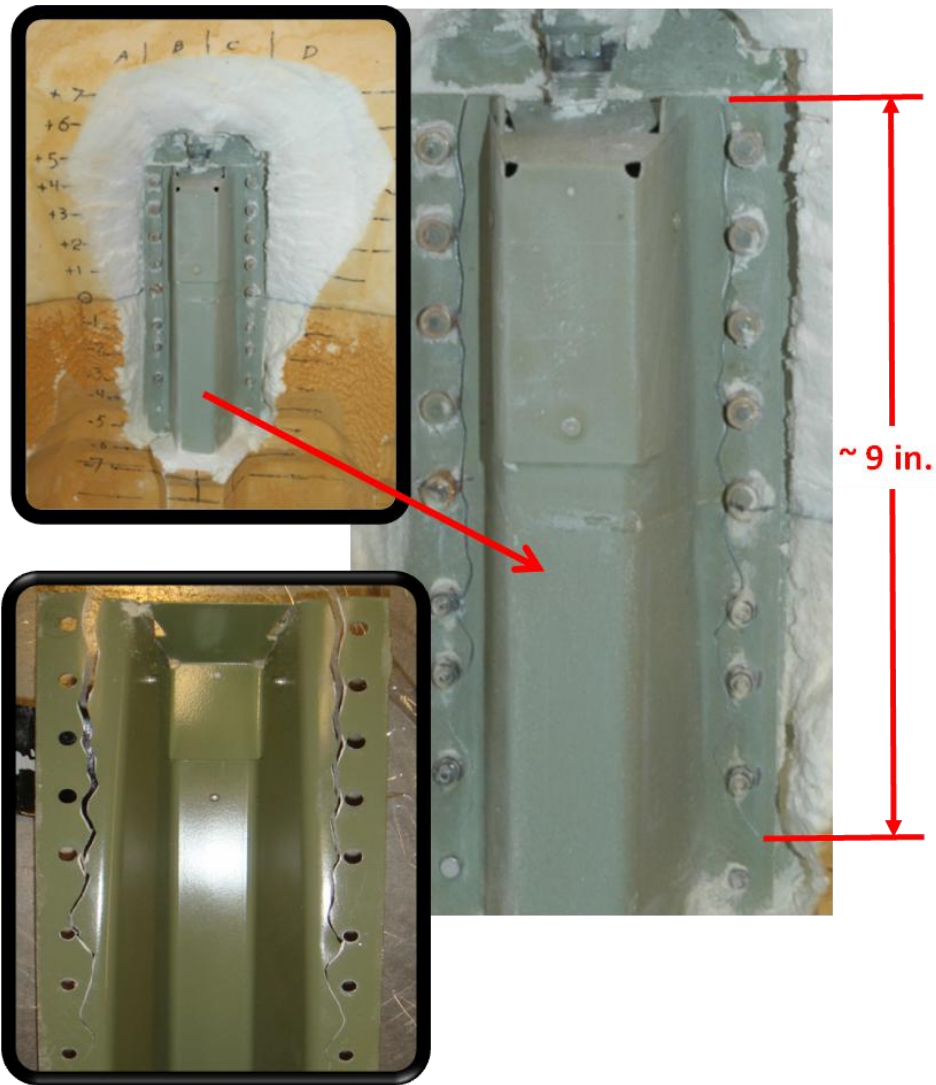

Figure 2. Stringer cracks discovered after STS-133 launch scrub. ET-137 stringer S7-2 shown. (Bottom left inset: stringer S7-2 after removal from ET-137 and foam residue cleaned off.)

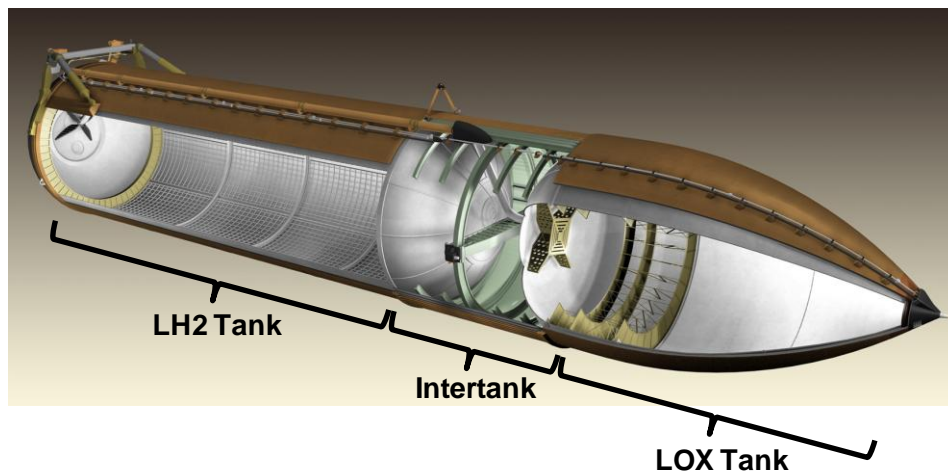
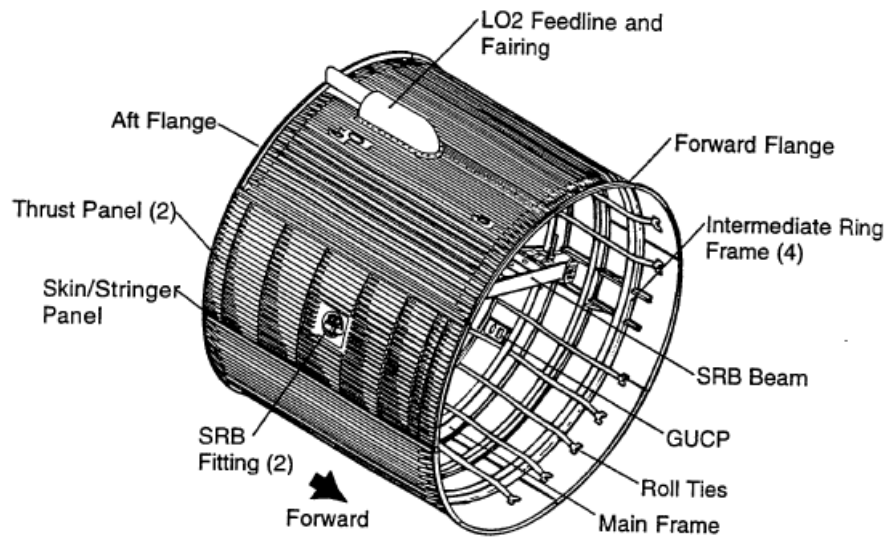
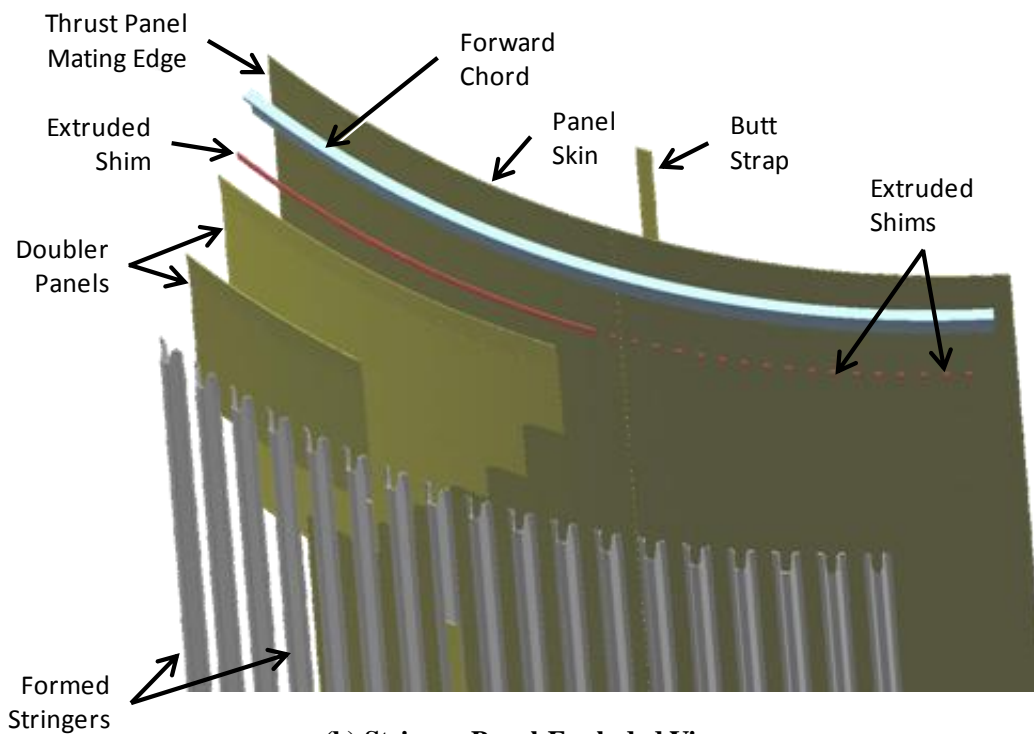

Figure 3. Super Lightweight External Tank.



(a) Intertank Assembly



(b) Stringer Panel Exploded View

Figure 4. ET intertank and stringer panel assembly.

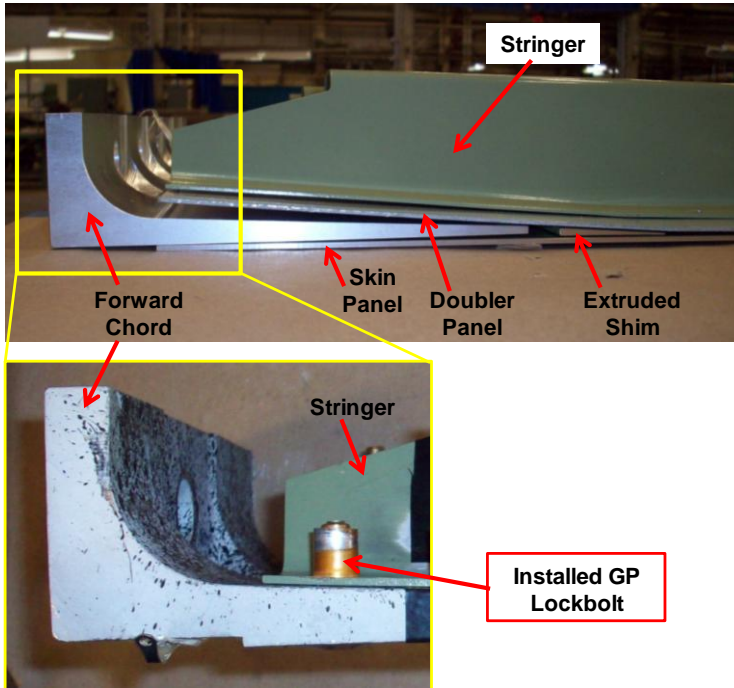

Figure 5. LOX end stringer, skin, and chord assembly.

However, the orientation of the ET relative to the launch pad fixed and rotating support structures was such that no access was possible at the pad to perform x-ray inspection of any of the stringers on the opposite side of the intertank (farthest from the Orbiter).

The two stringers were repaired in-situ at the launch pad by removing several inches of the forward end of each damaged stringer and splicing on an equivalent length taken from new stringers. Aluminum sheet stock doublers formed into a shape resembling the letter 'Z' were overlaid and fastened on the splice location to mechanically tie each portion of new stringer to the remaining portion of original stringer. The SOFI was then manually re-applied, allowed to cure, and trimmed to meet flight requirements. The remnants of the two stringers containing the cracks were shipped first to the MAF and later to the MSFC for forensic engineering.

Concurrent with these efforts, Lockheed Martin began to review the structural verification of the SLWT intertank stringers. Launch pad observation video recorded during propellant loading for the launch attempt was reviewed to determine the time of SOFI failure, which indicated the time of the underlying stringer failure. By correlating the time of video observations to the propellant loading schedule, it was

III. Initial Response

Work began immediately within the Shuttle community to understand root cause and scope of the stringer issue and plan for repair of the two cracked stringers and surrounding SOFI. There was an emphasis to minimize delay of the next launch attempt, but without compromising flight safety. The two cracked stringers were located on the side of the ET adjacent to the Space Shuttle Orbiter on the intertank skin/stringer panel closest to the port SRB (identified as panel 2 as shown in Figure 6). Non-destructive x-ray inspection was used in-situ at the launch pad to examine the forward and aft ends of the remaining stringers on the side of the intertank adjacent to the Orbiter, with the exception of the aft end of a few stringers in close proximity to the Orbiter where clearance and access issues precluded inspection. Of the stringers inspected, no additional cracks were detected.

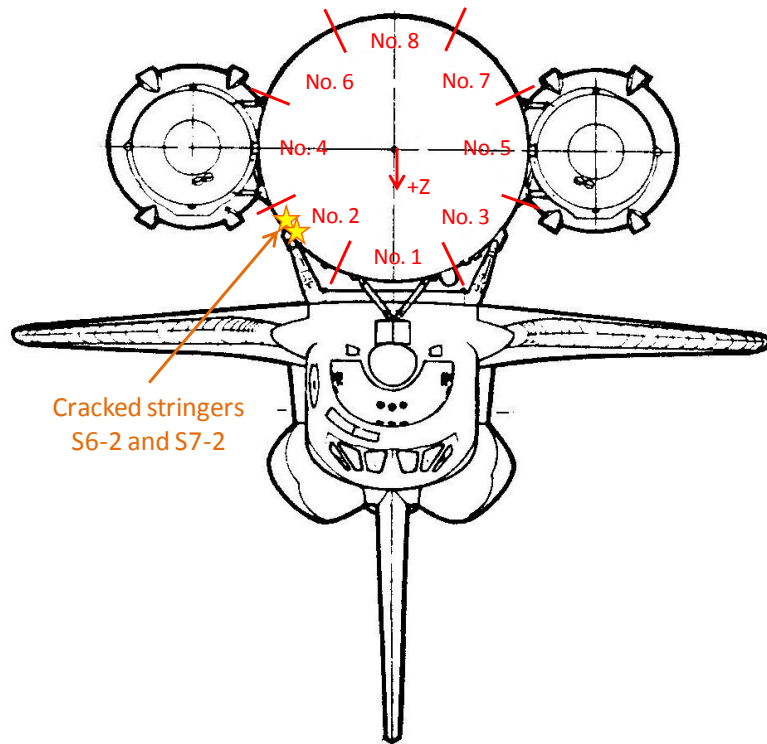

Figure 6. ET-137 intertank panel identification numbers and cracked stringer locations.

determined that the stringer failed at about the same time that the LOX liquid level reached the LOX tank ring frame to which the forward end of the intertank was bolted. Hence, cryogenically-induced deflections were suspected as a contributing cause of the stringer cracks. However, the LOX loading procedure was nominal, and the cryogenically-induced deflections were theorized to be no different than for previous ETs.

The LOX cryogenic temperatures cause a radial shrinkage of the aft ring frame of the LOX tank as the liquid level reaches that elevation during propellant loading. The forward flange chords of the intertank are bolted to the LOX tank frame and are constrained to follow this displacement. However, since the intertank is a dry structure that does not contain cryogenic propellant, a large temperature gradient exists at the forward end of the intertank. Bending is induced in the stringers as the forward end of the intertank deflects radially inward, but the warmer aft areas do not. This bending attempts to pry the stringer ends from the chords and skin, which is resisted by the mechanical fasteners attaching the feet of the stringers to the underlying structure, causing local bending in the stringer feet inboard of the fasteners (Figure 7).

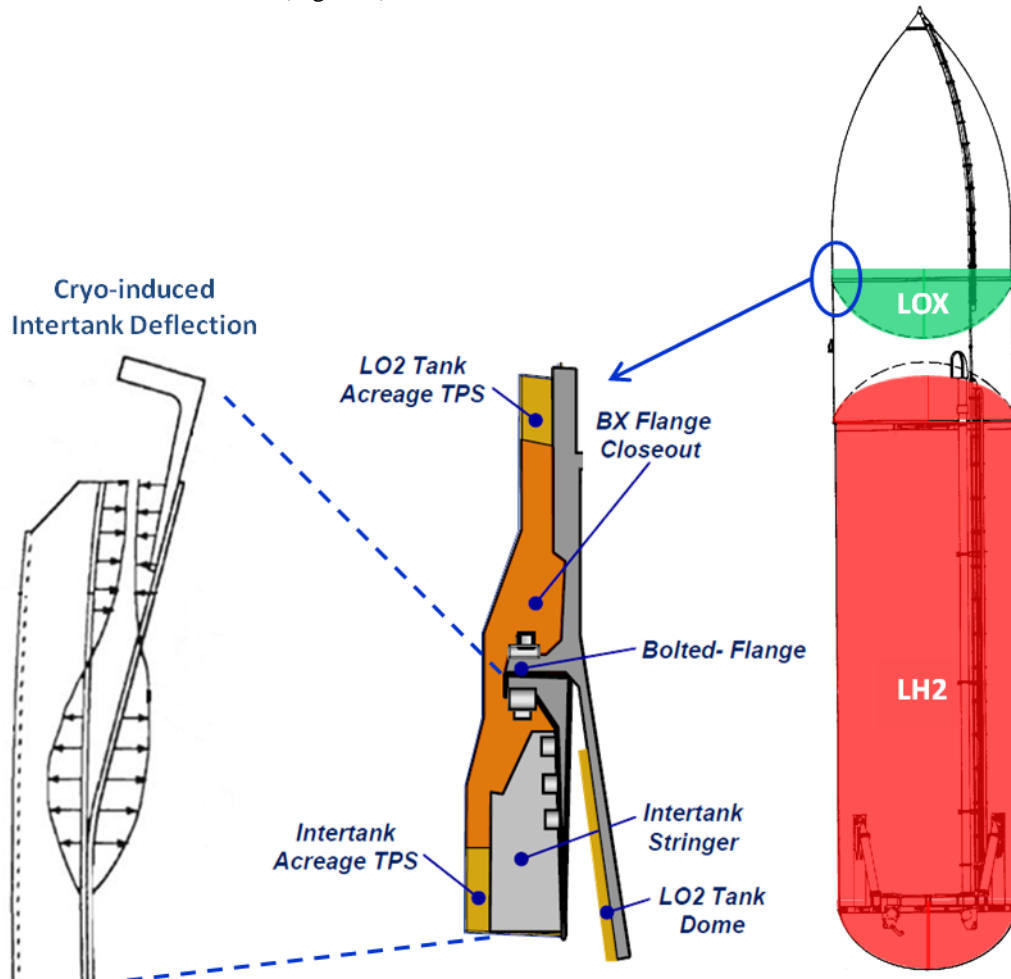

Figure 7. Notional cryo-induced stringer deflection due to LOX liquid level.

One of the early reviews Lockheed Martin performed of the structural capability of the stringer feet used an existing methodology for the analysis of classic aircraft details. As can be seen in Figure 8, it was noted that the free body diagram of the cross section of a stringer foot was similar to that of an aircraft structural detail commonly known as a “tension clip” or “tee.” A modified version of the heritage Lockheed stress memo, “Flange Bending Strength of Angles,” provided a standard analysis procedure for tension clips based on empirically-derived allowable tension loads for sheet metal angles [3]. Using stringer sidewall forces derived from expected thermal deflections and nominal stringer geometry and properties, the tension clip analysis indicated that the stringers should have had adequate structural capability. The analysis did not explain the failures.

To check the validity of using the heritage analysis methodology for this application, Lockheed Martin conducted simple tension tests on cross sections of spare stringers obtained from the production inventory (Figure 9). Referred to as “clip tests,” the test articles were essentially one-inch lengths of the stringer hat section with one fastener through each of the two stringer feet anchoring the clip to a rigid base. A load frame was used to pull the clips away from the base, simulating the local loading condition created when radial contraction of the forward end of the intertank causes the stringers to bend. The initial clip tests confirmed that the analysis method was conservative in that the test articles demonstrated higher capability than predicted by analysis.

Within two weeks of the scrubbed launch attempt, repairs to the two cracked stringers and surrounding SOFI were completed. However, root cause of the stringer failures was still unidentified, and it was unclear what rationale for flight readiness existed for an unexplained anomaly that: (1) posed the risk of catastrophic foam debris should it reoccur and (2) raised questions regarding the basic structural integrity of the intertank during flight.

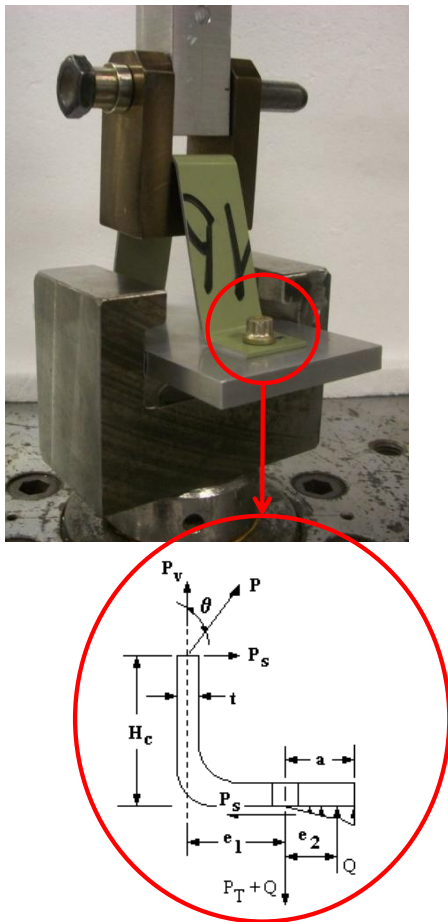

Figure 9. Lockheed Martin stringer “clip test.”

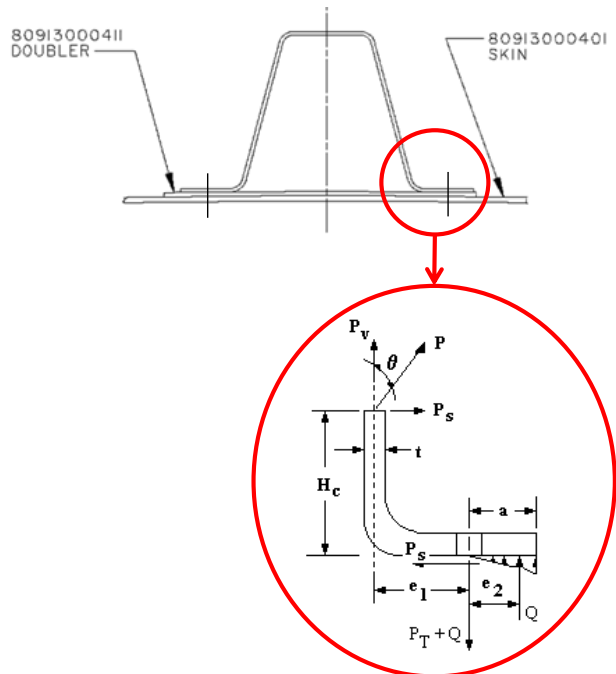

Figure 8. Stringer foot free-body diagram similarity to aircraft “tension clip.”

IV. Failure Investigation Activities

The investigation into the cause of the structural failure of the stringers can be summarized as having pursued the scenario that either the stringer capability was less than expected or that the stresses were greater than expected. Each of these two possible causes was further developed into their potential sub-causes (Figure 10). Within the effort at the MSFC, these two main branches were the focus of an ad-hoc Material Failure Analysis Team (FAT) and an ad-hoc Stress Analysis Team, respectively.

Given the successful flight history of the SLWT design and seemingly routine, benign loads at the time of stringer failure, it seemed most likely early in the investigation that an anomalous material defect or under-strength issue would be at cause. However, fractography conducted at the MSFC of the remnants of the two cracked stringers revealed there were no pre-existing cracks or defects and that the stringers fractured in overload with no evidence of fatigue [4, 5]. More precisely, the failures initiated near the second and third fasteners (from the chord) due to initial bend crack formation in mode I tension on the bottom of the stringer feet, propagating through the thickness, where mode III tearing opened the cracks fully along the stringer feet. Additionally, testing of coupons cut from the remnants concluded that the stringers satisfied the material specification requirements for minimum ultimate tensile strength, minimum yield tensile strength, and elongation.

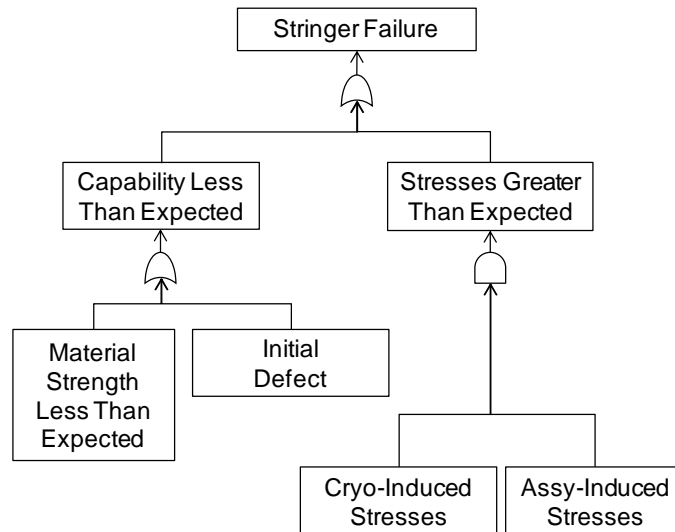

Figure 10. Simplified stringer failure fault tree.

The stress analysis and structural testing activities at the MSFC evolved into six major efforts:

- (1) finite element analyses of the forward end (LOX tank end) of the stringers to understand fundamental structural responses to transient, cryogenically-induced temperature gradients, and to quantify stresses induced by possible assembly conditions;
- (2) analyses of photogrammetric deflection data of the intertank stringers collected during a tanking test conducted as part of the investigation;
- (3) finite element analyses of retro-fit structural reinforcements added to all Al-2090 stringers;
- (4) static load testing and corresponding finite element analyses of stringers to study their behavior when subjected to flight-like deflections and to assess the effectiveness of the retro-fit structural modification;
- (5) finite element analyses of a heritage, flight-like skin/stringer panel compression test to understand structural stability implications; and
- (6) finite element analyses of the aft end (LH2 tank end) of the stringers to quantify stresses induced by deflections resulting from the transient thermal environments at the interface between the intertank and the LH2 tank.

The analysis efforts of the MSFC Stress Team were conducted concurrently with the test and analysis efforts of all other participants in the overall investigation, including the Material FAT, Lockheed Martin, and the NESC. The MSFC analysis strategy was adjusted as new information became available. Teleconferences were held at least weekly to discuss structural analysis details with Lockheed Martin, engineering representatives of the Space Shuttle Program, and the NESC. The six major MSFC analysis efforts are further described in the following sections.

A. Finite Element Analyses of Stringer Prelaunch, Flight, and Assembly Conditions at the LOX Tank Interface

As mentioned previously, an early focus of the stress analysis investigation was on studying the cryogenically-induced deflections during the transient temperature conditions resulting from the prelaunch operation of filling the LOX tank. However, failing to show that expected cryogenically-induced deflections explained the stringer failures, Lockheed Martin began to study the possible contribution of off-nominal assembly-induced stresses in the feet of the stringer. The MSFC Stress Team began an independent analysis effort to confirm Lockheed Martin's findings, and to gain understanding of the structural behavior so as to be able to provide knowledgeable opinions to NASA engineering and project management.

Finite element (FE) models were created to study deflections and stress conditions along the feet of the stringers. These MSFC analyses were conducted using the ANSYS[†] commercial finite element code with progressively more detailed models. Three-dimensional, 8-node brick elements were used, and the rotational symmetry of the intertank stringer panels and LOX tank was utilized such that only one-half of a stringer and the underlying skin were

[†] ANSYS is a registered trademark of SAS IP Inc.

modeled (Figure 11). Different models were created to replicate the different configurations of stringer and underlying skin that existed circumferentially around the intertank. Portions of the adjacent LOX tank ring, barrel, and aft dome were modeled to provide appropriate boundary conditions. Runs were made with simplified representations of the fasteners and with the fasteners explicitly modeled with solid elements. Different profiles of stringer temperature as a function of distance from the LOX tank interface (representing snapshots in time of the transient thermal conditions) were mapped onto the mesh to study resulting stringer deflections and stresses. The stringer model with the steady state temperature profile achieved while filling the LOX tank was further augmented with compressive loads to study stresses in the feet of the stringer under the influence of ascent flight loads [6]. Linear elastic material properties were used. Additionally, it was acknowledged that the magnitude of the peak stresses from the analysis could not be stated with sufficient accuracy to calculate a meaningful factor of safety or failure margin because it was just a linear analysis, and it was unclear what material allowable should be used. Rather, the results were used for qualitative comparisons of stringer response to different thermal profiles, flight loads, and underlying skin configuration.

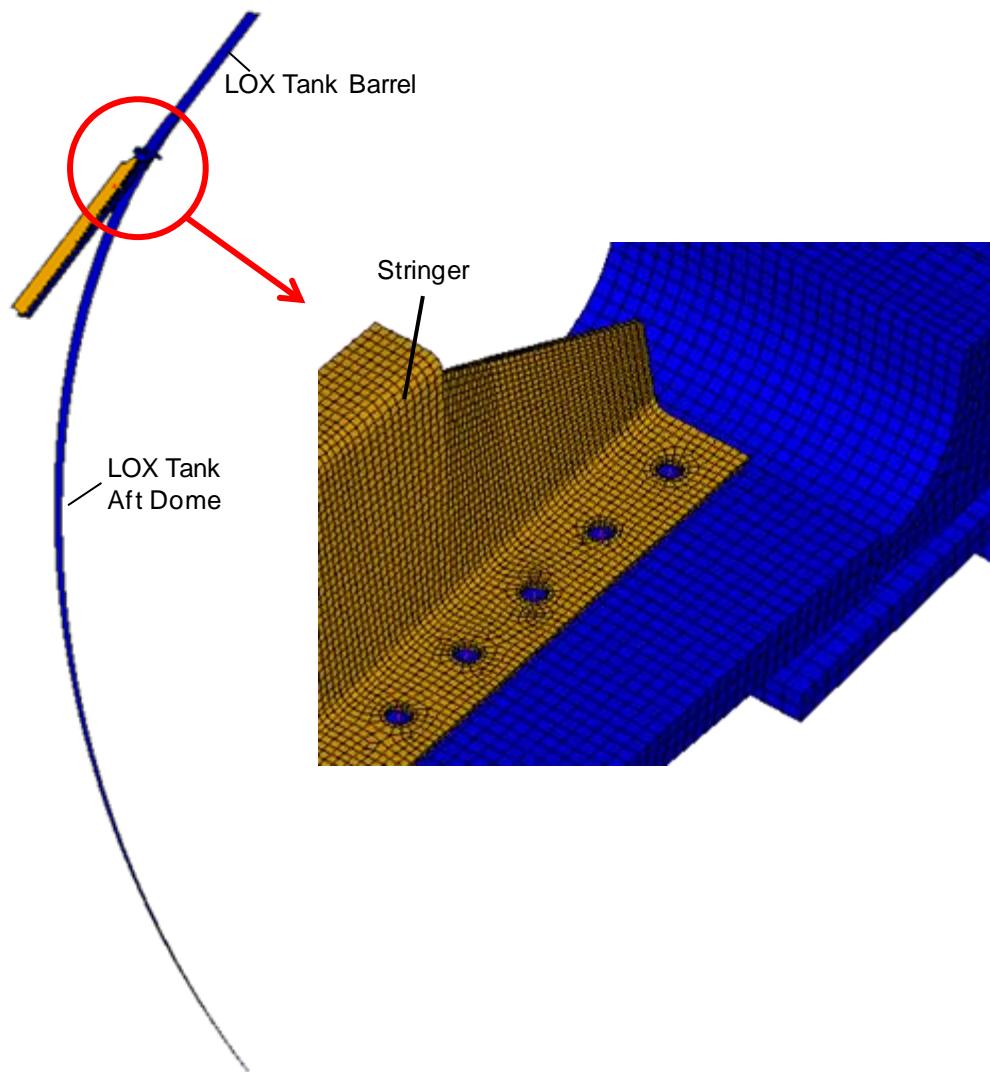

Figure 11. FE model of stringer and adjacent LOX tank structure.

Initially, only the nominal skin/stringer, as-designed configurations were modeled. Results were obtained for stringer displacement, chord rotation, internal forces in the sidewall of the stringer, and stresses in the feet of the stringer (Figure 12). The results indicated that:

- Local peak stresses in the region of the first three fasteners (where the fractography indicated that the failures had initiated) occurred during the temperature profiles corresponding to the LOX liquid level reaching the ring frame to which the intertank forward chord was attached;
- The different skin configurations under the stringers had an effect, with the stringers closest to the thrust panels (where doubler skins were used and where the first observed stringer failure occurred) seeing higher peak local stresses at the forward fasteners due to transient thermal conditions. (Recall that fractography indicated that the failures initiated in the region near the second fastener from the chord.)
- Local peak stresses in the region of fastener locations 4 through 9 resulted from steady state thermal conditions combined with ascent flight loads.[‡]

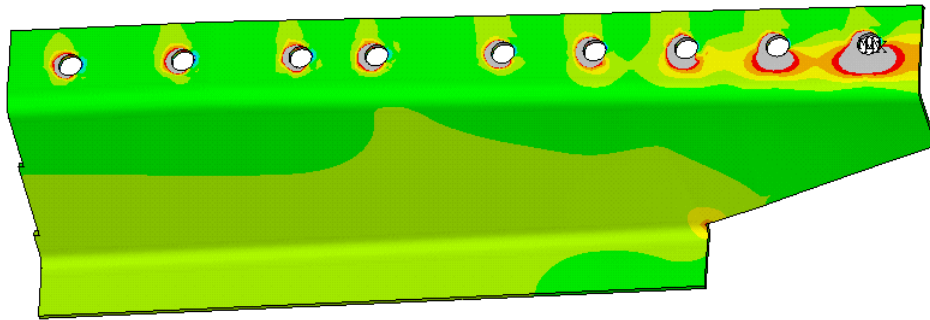

Figure 12. Example FE result of stringer foot 1st principal stress on the bottom of the foot at the 3700 sec thermal transient.

Other stringer analyses were conducted with this FE model to study possible flight worthiness rationale. Some engineers had questioned whether the stringers experienced greater peak stresses during prelaunch propellant loading operations compared to flight such that if the stringers did not fail during prelaunch, they would be unlikely to fail during flight. In other words, did propellant loading act as a pseudo proof test on the stringers for flight environments? If true, such logic would have been potentially useful in a flight readiness assessment for the next launch attempt in that the stringers would have been “proofed” by exposure to the prelaunch environments of the initial launch attempt. (Recall that most of the stringers had been non-destructively inspected and structural integrity confirmed following the scrubbed launch attempt.) The FE results indicated that generally the region near the first three fasteners experienced peak stress during propellant loading, but the region around the next several fasteners experienced peak stress during flight, although the magnitude of those peaks was not typically as high. It was not conclusive that definitive proof test logic for the flight readiness rationale existed.

These same FE models were modified as necessary to study stresses resulting from possible assembly fit-up conditions. The design drawings of the stringer panels specified that shims were to be used when attaching a stringer to a skin panel if a gap greater than 0.030 inches existed between the stringer foot and skin. One theory for unexpected stresses was that gap conditions existed during assembly that required shimming, but that the shims had been inadvertently omitted, inducing high residual stresses in the stringer feet during fastener installation. This theory was studied with the FE model by including excessive (but credible) gaps under several fasteners at the end of the stringer, and then simulating preloading of the fasteners, followed by application of thermal deflections (Figure 13). The anomalous gap conditions hypothesized in these analyses did not introduce significant additional stresses above the baseline as-designed conditions, so it was considered unlikely that these particular conditions contributed to the failure.

Another source of possible assembly-induced stresses was theorized to be variations in the stringer geometry at the hot-formed ends that were fastened to the chord. Visual examination of typical stringers showed that the feet of the stringer hat-section exhibited a slight taper as a result of the forming process (what was referred to as a “toe

[‡] The stress analysts adopted a numbering system to identify the location of the stringer attachment fasteners where the end-most fastener (closest to the adjacent propellant tank) is labeled fastener number one, and the adjacent fasteners on the same foot are numbered sequentially higher moving inboard from the end of the stringer.

down” condition) as seen in Figure 14. An initial toe down geometric condition would cause bending in the stringer foot during fastener installation, resulting in stresses in the foot that would be additive to stresses caused by the prelaunch thermal transient. This condition was studied analytically by giving the FE model an initial toe down condition, and sequential installation (preloading) of the forward fasteners was simulated to obtain stringer internal forces and stresses. The results indicated that it was possible to induce assembly stresses that would be additive to subsequent cryogenic deflection-induced stresses.

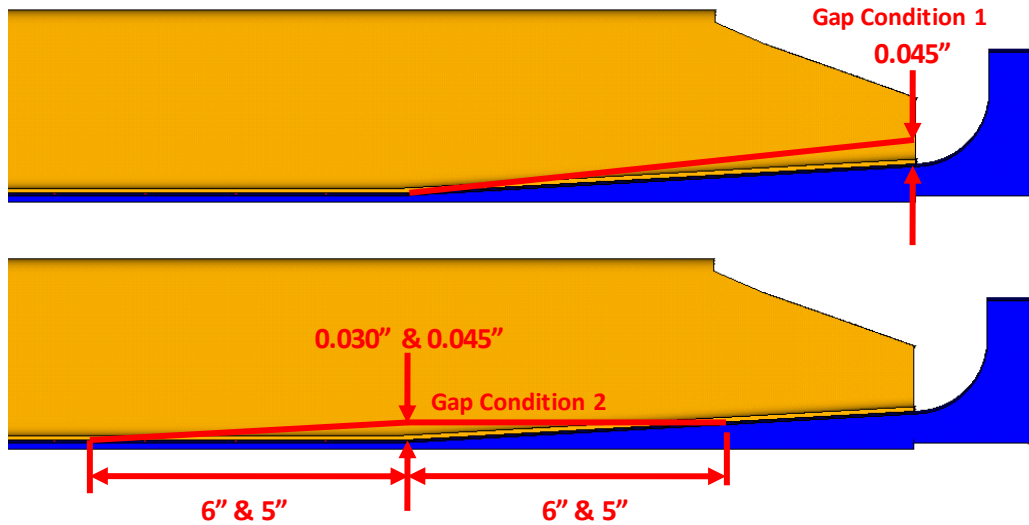

Figure 13. FE simulations of possible assembly stress scenarios.

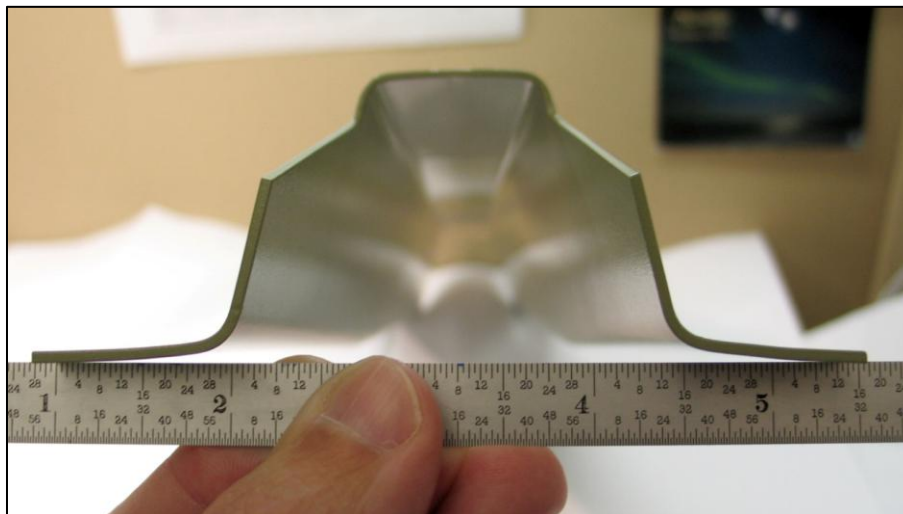

Figure 14. Stringer “toe down” geometry variation at the hot formed ends.

B. Tanking Test Photogrammetry Analysis

Early into the failure investigation, the Space Shuttle Program decided to conduct an instrumented tanking test of ET-137 to collect data to help understand the stringer failures. A tanking test is where propellants are loaded into the ET, generally following the same procedures used in preparation for a launch. This test had four goals: (1) to gather full-scale environmental data to assist in anchoring analyses; (2) to look for a global structural issue with the intertank rather than a local stringer issue (e.g., “oil-canning”); (3) to confirm the integrity of repairs that had already been effected on two of the cracked stringers; and (4) to verify re-alignment of the Ground Umbilical Carrier Plate

(GUCP), which had been the source of the hydrogen leak that caused the November 5 launch scrub [7]. The test included pressurization of the LOX and LH2 tanks to flight pressure.

Special instrumentation for the test included 21 strain gage rosettes and 40 thermocouples mounted externally to the skin and stringers on two intertank panels near the LOX tank interface, including one of the stringers that had previously been repaired. SOFI was removed in the instrumented regions to allow for application of the gages and thermocouples, and then the SOFI was reapplied over the instrumentation so the thermal boundary conditions during the tanking test matched those seen during the previous launch preparations. Instrumentation on the internal side of the intertank skin was ruled out due to access issues inside the intertank in the region of interest, concerns over the routing of the wiring harnesses that would be required, logistics concerns over the number of strain gages immediately available, and schedule concerns. Instrumentation at the ends of the stringers near the LH2 tank was ruled out since the cryo-pumping phenomenon greatly raised debris concerns with modifying and then repairing the SOFI in the region of the LH2 tank flange.

Engineers at the MSFC strongly advocated for an attempt to use photogrammetry to measure deflections of the stringers and intertank forward chord. Photogrammetry is a non-contact optical method that uses stereographic digital image correlation to measure deformation on a surface. It requires the application of specular markers to map the deformation. Since the SOFI was required to be in place during the tanking test, the photogrammetry required painting a speckle (dot) pattern on the external surface of the foam (Figure 15). Approval was granted to try photogrammetry on two regions of the intertank on approximately opposite sides of the intertank from each other [8]. The field of view of the camera systems limited both regions of study to the forward ends of several stringers and the adjacent LOX tank area.

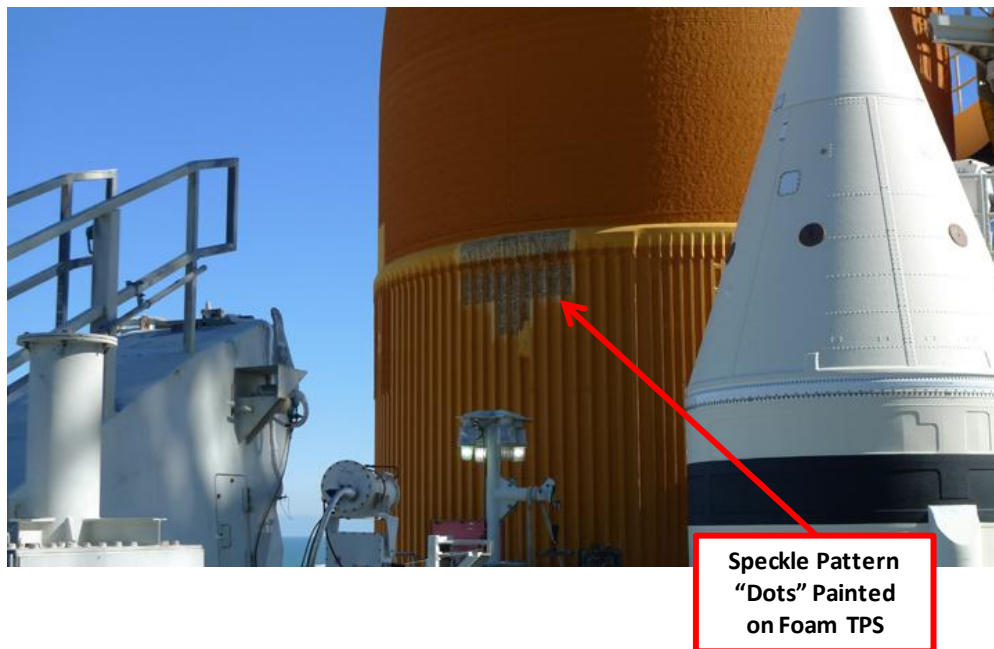

Figure 15. ET-137 tanking test photogrammetry study of stringer deflections near the LOX tank.

The test successfully met all goals. There were no observations of unexpected structural behavior. Strain, temperature, and deflection data were successfully collected. All measured stresses were thought to be well within the capability of the design; however, correlation to models was difficult due to the limited instrumentation. The thermocouple data was correlated to a thermal analysis model of the transient temperature conditions. Post-test visual and non-destructive inspection of the two stringer repairs was completed with no anomalies identified [9]. The GUCP performed nominally with no leaks detected.

Of the two intertank regions studied with photogrammetry, only one of the regions provided data with sufficient quality for meaningful study. The data was subsequently analyzed to discern cryogenically-induced deflections from rigid body movement during the tanking test. It was assumed that deflections of the outer surface of the SOFI were essentially the same as the underlying stringers and flanges. Through mathematical post-processing of the data, the radial contraction of the forward end of the intertank due to cryogenic temperatures and the resulting

bending of the stringers was quantified and compared to ANSYS FE predictions from the effort previously mentioned. The FE analysis had shown that the stresses in the stringer feet were particularly sensitive to how much the forward chord rotated during the thermal-induced deflections, but the accuracy with which the FE model predicted the chord rotations had been the subject of some debate as it did not agree with other analyses. However, as shown in Figure 16, the photogrammetry data indicated that the ANSYS model very accurately predicted the average radial deflection and rotation of the intertank forward chord [10].

While the tanking test achieved all goals and the data it provided was useful in confirming the gross structural response of the intertank during propellant loading, it failed to provide any further insight into the cause of the stringer cracks. Following the tanking test, the program management made the decision to roll the Space Shuttle stack back to the Vehicle Assembly Building (VAB) where additional work platforms existed to perform x-ray inspections of the stringers that could not be reached on the launch pad. This inspection revealed three additional stringers with similar cracks in their feet near the LOX tank interface, making a total of five known stringer failures, two of which had already been repaired (Figures 17 and 18). All three of the newly detected cracked stringers were located in the area where good quality photogrammetry data was collected, but no indication of the stringer failures was indicated on the surface of the SOFI or in the photogrammetry data. Since these three stringers had not been inspected prior to the tanking test, it was not known if the cracks occurred as a result of the tanking test or if they occurred during LOX loading for the original launch attempt as with the other failures. The three stringers were repaired similarly to the original two cracked stringers. No cracks were detected at the stringer ends near the LH2 tank.

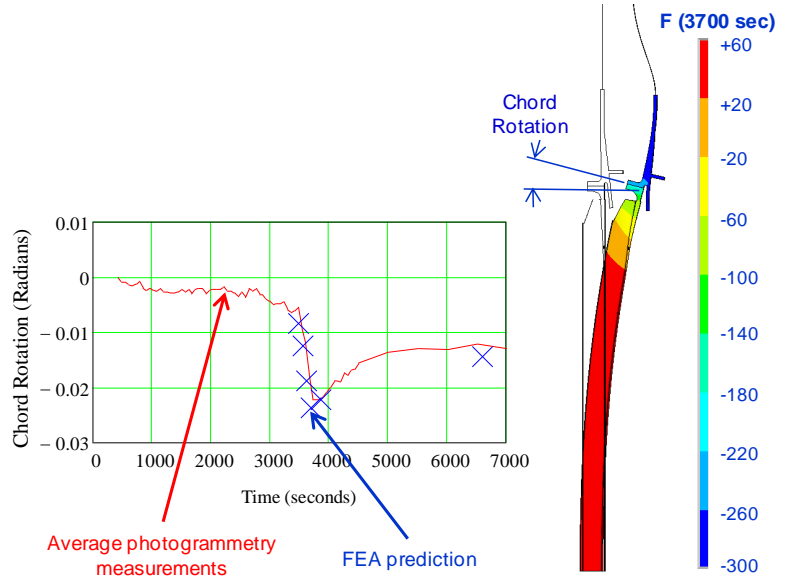

Figure 16. Intertank forward chord rotation due to thermal transient.



Figure 17. Example stringer crack detected during post-tanking test x-ray inspection.

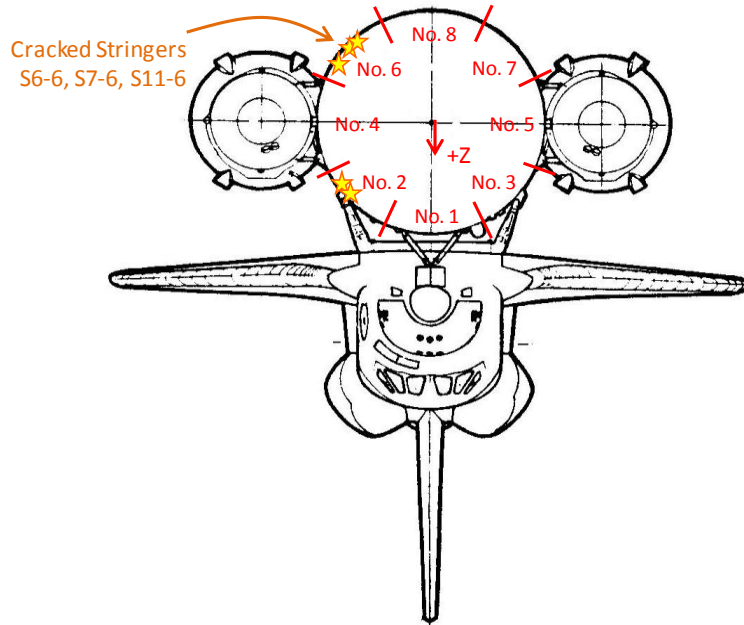

Figure 18. Location of additional stringer cracks detected after ET-137 tanking test and roll-back to the VAB.

the approximately 100 stringers on ET-137 were likely from either of the two suspect material lots (the stringers were not serialized, lot traceable items, so this could not be conclusively determined). Since only five of the suspect stringers had cracked, the material behavior was not thought to be the sole cause of the failures.

C. Finite Element Analyses of Radius Block Reinforcements

Lockheed Martin proposed the corrective action of retro-fitting the feet on every Al-2090 stringer with structural reinforcement in the region of the first several attachment fasteners at the forward end of the intertank. These reinforcements, known as “radius blocks” because they fit into the radius between the stringer sidewall and foot, were 0.190-inch thick strips of aluminum alloy Al-2024 and were mechanically fastened to the outside of the stringer feet (Figure 19). Similar reinforcements were already in use by design on stringers near cutouts in the intertank. The repair required the removal and replacement of several of the forward stringer attachment fasteners. However, due to the risk of possible collateral damage to the LOX tank dome in removing the forward-most fastener, this fastener was untouched, and the radius blocks did not cover the stringer feet at the forward fastener.

Several FE analyses were conducted by the MSFC Stress Team to study the effect of the radius blocks in reducing stresses in the stringer feet due to prelaunch and flight environments. Additionally, the analyses were conducted to ensure that the repair “did no harm;” i.e., to ensure that the radius blocks did not create unintended and detrimental stress concentrations, particularly at the forward and aft edges of the radius block.

One series of analyses used modified versions of the ANSYS models previously mentioned. The radius block and fasteners were explicitly modeled, contact was simulated between the radius block and the stringer foot, and linear elastic material properties were used. The models did not

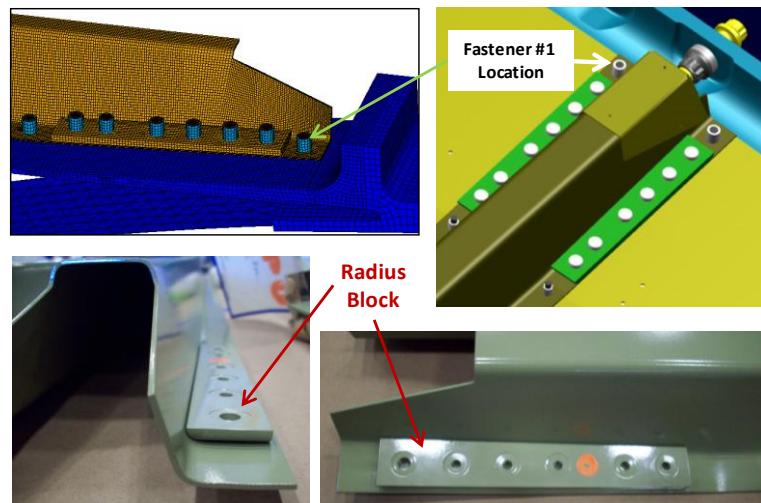

Figure 19. Radius block reinforcement of stringer feet.

Sidebar: Anomalous Material Behavior

By about the sixth week of the failure investigation, the findings of the Material FAT were increasingly suggesting that an out-of-family material behavior that was not controlled by the material acceptance requirements was a likely contributor to the crack failures. Specifically, testing of remnants of the failed stringers indicated higher than typical yield tensile strength and lower than typical fracture toughness. (The material exceeded the minimum specification requirement for yield tensile strength; fracture toughness was not a requirement in the material specification.) In addition to the lower than typical fracture toughness, fracture tests of the failed stringer remnant material demonstrated unstable fracture (tearing resistance) compared to control samples. This out-of-family behavior was eventually traced to stringers manufactured from two specific lots of Al-2090 sheet. Lockheed Martin determined that more than half of

include any features to simulate possible sources of assembly stress. By running critical load cases of the model with and without a radius block, and plotting the principle stress patterns on the underside of the stringer foot, it was possible to study whether the addition of the radius block changed the shape or magnitudes of the stress contour and to qualitatively determine radius block effectiveness (Figure 20). The findings of this assessment were:

- The addition of the radius block did not add new high stress regions;
- The stress in the foot of the stringer in the region near the first five fasteners during the critical thermal transient was significantly reduced with addition of the radius block;
- The stress in the foot of the stringer in the region near the fasteners at the aft end of the radius block saw only moderate increases with the addition of radius blocks for the steady state thermal condition with ascent compressive loads, but the stress remained low relative to the magnitude of the stresses near the forward fasteners.

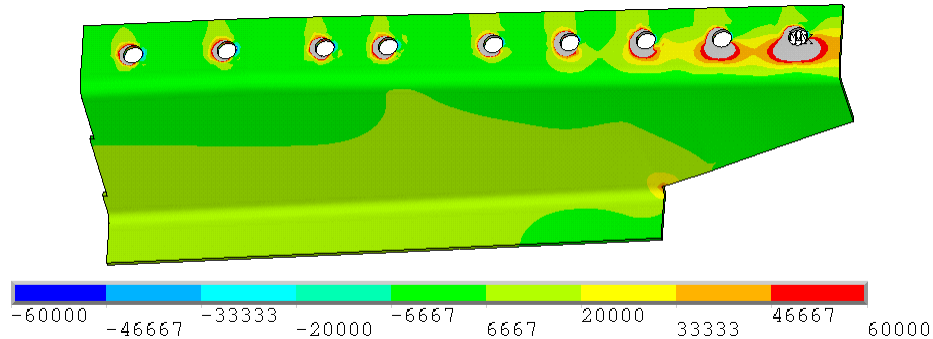

(a) 3700 sec without Radius Block

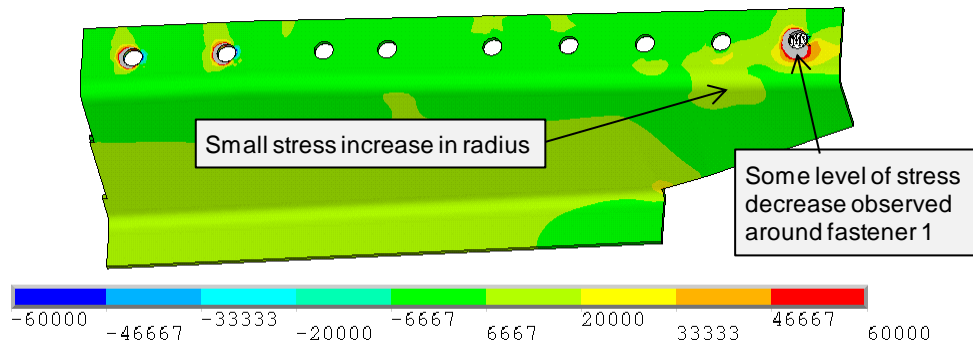

(b) 3700 sec with Radius Block

Figure 20. Example FE results comparison of stringer foot (with single doubler) 1st principal stress (psi) on the bottom of the foot at the 3700 sec thermal transient with and without radius block reinforcement.

Parametric analyses were conducted to study radius block performance in the presence of allowable dimensional tolerance stack-up conditions between the stringer foot and radius block. The parametric analyses used a FE model of the Lockheed Martin clip test geometry. The purpose was not to compare analytical predictions to test results, but rather to use the simple sub-component test article geometry as an analytical test bed for understanding the sensitivity of stringer foot stresses and strains to dimensional variation. These analyses were conducted using the ABAQUS[§] commercial FE code. Three-dimensional brick elements were used to model the geometry of the clip tests. The sensitivity of stringer foot stresses and strains to tolerance conditions was studied by parametrically varying the model geometry for conditions such as fastener location relative to the sidewall of the hat stringer, both with and without radius blocks (Figure 21). The results showed that the radius blocks significantly mitigated strains induced by some credible tolerance conditions.

[§] ABAQUS is a registered trademark of Dassault Systèmes.

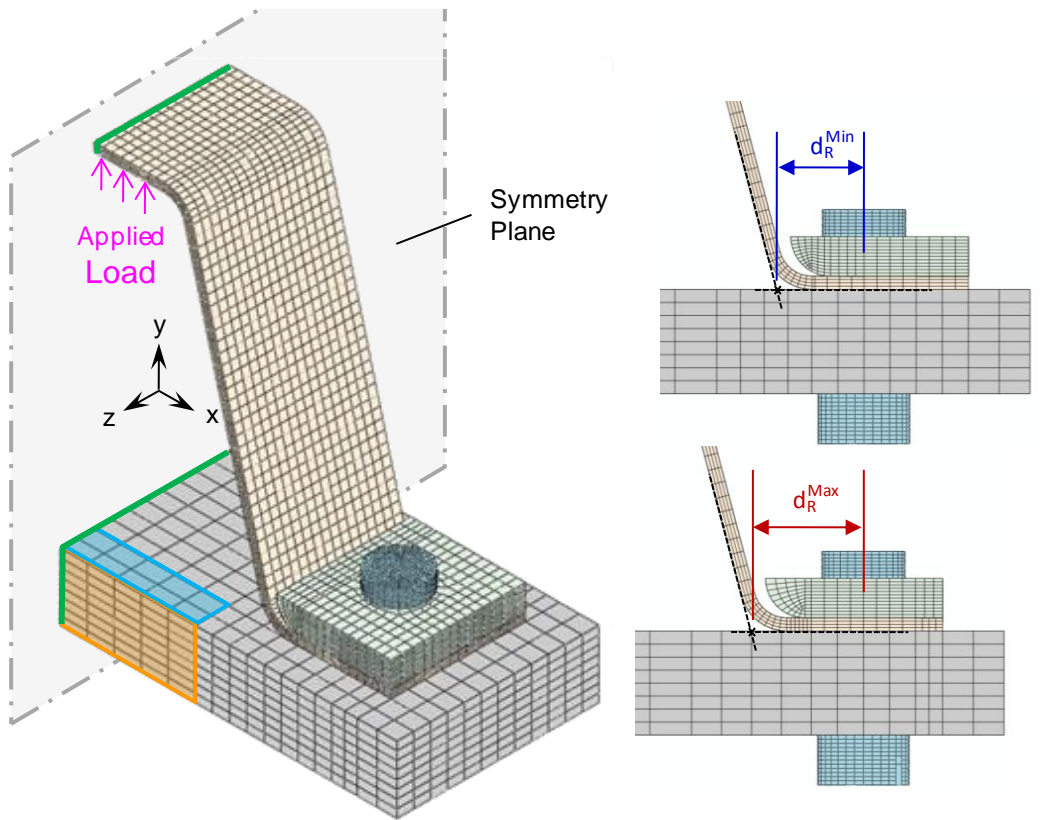

(a) FE model of clip test geometry

(b) Parametric dimension of interest

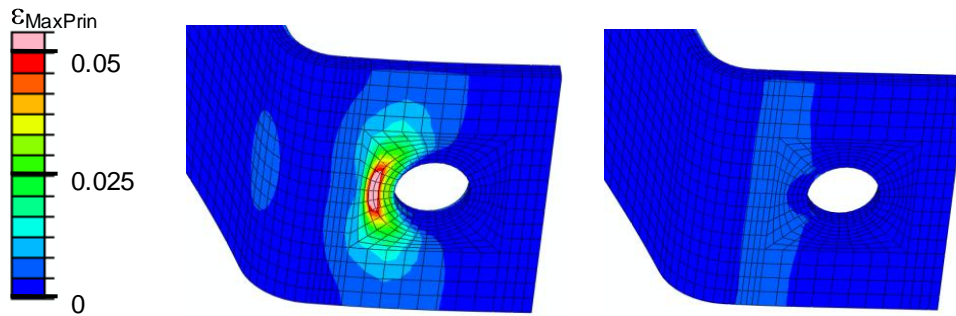

(c) Maximum principal strain on bottom of foot without radius block (left) and with radius block (right)

Figure 21. Parametric analyses of clip test specimens with and without radius blocks.

D. Static Load Testing of Stringers

Planning began very early in the investigation for some type of static load testing of stringers should such data be needed to support the investigation or to support structural re-certification. It was decided almost immediately that the test would need to simulate the cryogenically-induced deflections that cause stringer bending. Questions raised during planning sessions included whether the test needed to be conducted at cryogenic temperatures, whether the test needed to include compressive loads on the stringers, and whether the test articles could be individual stringers or whether edge effects would require the test article to be a panel with several adjacent stringers. The aggressive schedule of the investigation led to an approach to start simple, but plan for additional test capabilities to be added

later if needed. Thus, it was decided the initial tests would be to simulate cryogenic deflections on an individual stringer (with underlying skin and chord) in a room temperature environment. The test apparatus was designed to accommodate a panel with up to three stringers if needed, and it was designed so that the capability to apply compressive load on the stringers could be added in the future.

The test apparatus for what would eventually become colloquially known as “single stringer bending tests” was assembled at the MSFC Materials Environment Test Complex (METCO) facility. The test configuration is shown in Figure 22. Each stringer test article was approximately 40 inches long and consisted of the forward end of a single stringer attached via actual flight fasteners to an approximately 5-inch wide cross-section of skin, extruded shim, and chord. The stringer test article was anchored to the test fixture at the aft end. At the forward end, the article was attached to load blocks with a single bolt through the chord simulating the local attachment of the intertank chord to the LOX tank ring frame. The load blocks were mounted on linear bearings to allow for axial and transverse stringer displacement but prevent free rotation of the chord. A wedge-shaped shim, installed between the chord and load block, was used to fix the chord angle (relative to the load block) to the worst case value predicted by the ANSYS FE analysis and validated with the tanking test photogrammetry data. A hydraulic jack was used to apply a transverse load, bending the stringer over two fixed, offset fulcra to simulate the cryogenically-induced displacements. The location and offset of the fulcra were determined from basic thermal deflection calculations to induce a flight-like deformed shape into the stringer and to create maximum stresses in the feet of the stringer in the vicinity of the first few fasteners as predicted by the prelaunch analyses.

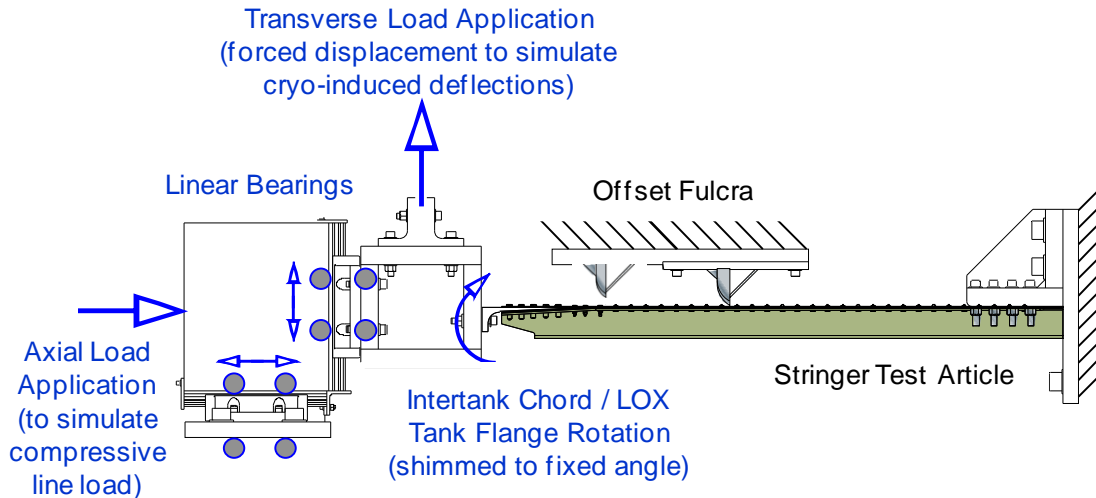

Figure 22. Single stringer bending test setup.

Initially, it had been envisioned by the stress analysts that the focus of testing would be to collect load, strain, and deflection data to validate the FE modeling approach used to study prelaunch and flight. On the very first test runs it was seen that when stringers fabricated from suspect material were tested to failure in this apparatus, the crack failures experienced on ET-137 could be accurately reproduced; i.e., a sudden brittle fracture of the feet of the stringer just inboard of the fasteners (Figure 23). The primary focus of the tests soon changed to become a study of

the relative performance of stringers subjected to repeatable load conditions. The focus became to create a test bed to comparatively demonstrate the capability of stringers fabricated from suspect and nominal materials, each with and without radius blocks. Approximately thirty stringers were tested, many of which were cut from the partially completed intertank for what would have been ET-139**. Instrumentation data collected during each test came from linear variable-differential transformers (LVDTs) mounted to both the fixture and the stringer test specimen and strain gages mounted on the stringer. Photogrammetry was used to great effect in the tests for full-field strain observation [11, 12]. High-speed digital video was also recorded.



Figure 23. Similarity of failure between cracked stringer removed from ET-137 (bottom) and stringer bending test article after failure (top).

** Fabrication and assembly of ET-139 was halted at the direction of NASA when it was determined that the tank would not be needed to fly out the remaining missions of the Space Shuttle Program.

The test results showed definite trends in stringer performance:

- Stringers fabricated from suspect material, and without added radius block modifications, failed in a sudden brittle fracture;
- Stringers fabricated from nominal (non-suspect) material, and without radius blocks, failed in a progressive manner until rupture, which generally occurred at a higher load than unreinforced suspect material stringers;
- Stringers fabricated from suspect material, but reinforced with radius blocks, failed at loads comparable to unreinforced, nominal material stringers, but the failure mode at rupture was still sudden brittle fracture; and
- Stringers fabricated from nominal material, but reinforced with radius blocks, demonstrated as good or better performance than unreinforced, nominal material stringers.

From these findings, and from review of the photogrammetry and instrumentation data, it was concluded that the radius blocks were effective in reducing stresses in the feet of the stringer and in restoring the structural performance of suspect material stringers to that of nominal material stringers. The results also added confidence that the radius block repairs did not add unintended detrimental side effects such as local high stresses or significant change in overall stiffness [11, 13].

Finite element analyses of the stringer tests were conducted in an attempt complement the comparative results with analysis correlation to measured test data. This correlation effort proved to be more difficult than anticipated. The findings and conclusions of the test program as listed above were able to stand alone in the flight readiness assessment without FE correlation. However, the correlation study was continued even after the flight of STS-133 to address the team's own concerns with the fidelity of the analyses, and if needed, to further bolster the structural verification of the ETs for the remaining two flights of the shuttle program. Eventually, excellent correlation was achieved between the test prediction models and the measured data [12].

E. Finite Element Analyses of a Stringer Panel Compression Test

Since skin/stringer construction is used to provide structural stability, an early concern following the discovery of the ET-137 stringer cracks was that intertank stability would need to be re-verified. As part of the original SLWT verification program in the mid-1990s, a compression test of a flight-like stringer panel was conducted at the MSFC (Figure 24). The test article was a five-stringer-wide panel that was half the length of an actual flight panel. The test incorporated compressive loads and used an adjustable cryogenic base and rollers to simulate flight-like temperature conditions and thermal deflections at the LH2 end of the intertank (the location of the bounding compressive line loads) [14]. However, the fixturing for this test was dismantled and many parts scrapped following the conclusion of the original test program. In case a similar test would be required for the current stringer failure investigation or the flight readiness rationale, FE analysis of this heritage test was pro-actively initiated for insight into the design and planning for a new test. The MSFC Structures Test Lab was able to retrieve a digital archive of all the strain gage and LVDT data collected during the original 1995 test. Based on information from the lab personnel, it was quickly

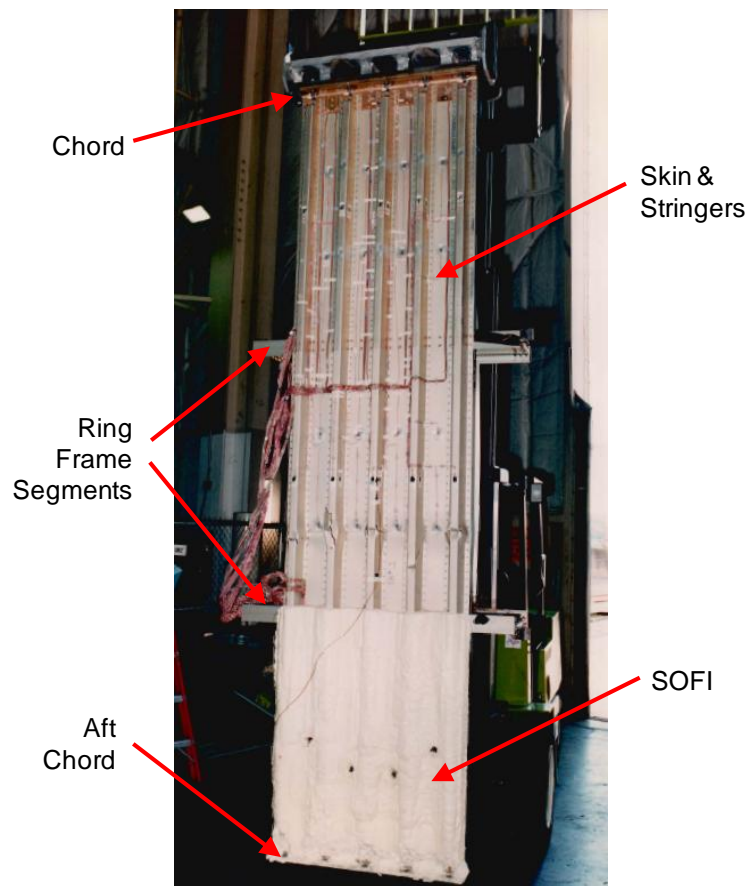

Figure 24. SLWT stringer panel compression test article as tested in October 1995.

determined by the ET project management that the cost and schedule to re-create the 1995 test apparatus was prohibitive given that a definitive need to repeat the test had not yet been identified. As an alternative, the project agreed to the stringer bending test effort described previously, with a contingency to modify that test for compressive loads if necessary.

The modeling of the heritage compression test was continued, not for test planning purposes, but rather to conduct fail-safe stability assessments on a stringer panel model that could be correlated to test data. Even though all known stringer cracks on ET-137 had been on the LOX tank end of the stringers, and this FE model was of the LH2 tank end of the stringers, it was recognized that the most severe compressive design loads in the intertank occurred at the LH2 tank interface, and it was decided that analysis of this test article would be insightful for determining structural capability.

The heritage compression test panel was modeled using the ABAQUS commercial finite element code. The finite element model was constructed primarily using shell elements with the fasteners modeled as linear elastic beam elements. Contact was simulated between the stringers, frame chord, and panel skin. Material plasticity was included in the skin and stringer materials.

The panel compressive load capability was predicted using an incremental, non-linear static solution procedure in ABAQUS. Several analysis steps were needed to adequately approximate the test through FE analysis. The first step involved preloading the fasteners to ensure contact between stringers, skin, and frame chord. A second step applied thermal loads and simulated thermal displacement at the aft end of the panel. A third step incrementally displaced the top of the panel to a load value just below the buckling load (~90%). The final step increased the displacement at the top of the panel model into the post-buckled region and implemented static stabilization to aid in convergence.

The model of the “as-tested” panel configuration correlated well with the measured test data retrieved from archive: the global stability failure mode and location matched photographic records of the original test, and FE-predicted stresses correlated well to those derived from strain gage measurements (Figure 25). The FE model over-predicted the compressive load at panel failure by almost 20%, but it was decided to address this unconservatism in subsequent iterations of the model through the use of a knockdown factor.

With analysis of the as-tested panel configuration completed, the FE model was modified, first to better match the current flight configuration of the intertank skin/stringer panels, and then to simulate cracks in the feet of the stringers representative of those found on ET-137. The changes to the panel configuration included adjustments to the skin thicknesses, increasing the thermal deflection to current estimates, and modifying the stringer material properties to match those of the suspect stringer lots (based on data from the FAT). Various crack lengths and numbers of cracked stringers were analyzed to study the tolerance of intertank stability to damaged stringers. It was concluded that cracks in only one stringer did not significantly affect the buckling capability of a panel, and multiple cracks in both feet of three adjacent stringers maintained a positive fail-safe margin of safety for stability (Figure 26). However, all scenarios with cracked stringers exhibited significant local skin buckling immediately under the stringers, which was identified as a concern for increasing the risk of foam debris due to potential SOFI debonding.

The findings from the analyses for the different damaged configurations contributed to flight readiness rationale by adding confidence that moderate levels of undetected or new damage to the STS-133 intertank would likely maintain positive fail-safe margins of safety against structural collapse [15, 16].

F. Finite Element Analysis of Stringer Prelaunch and Flight Conditions at the LH2 Tank Interface

Concurrent with the other FE efforts previously described, another analysis task was initiated to obtain stresses, forces, and displacements at the LH2 tank end of the intertank stringers to support an assessment of risk associated with the potential for stringer cracks to develop during LH2 Tank Fill and Ascent transient loading conditions [17]. A specific objective was to compare stringer peak tensile stresses and forces to corresponding results obtained from the separate FE analysis of the LOX tank end of the stringer, and from this comparison, make a determination on whether the propensity for stringer cracking at the LH2 tank end was more or less than the LOX tank end. Recall that no cracks had been detected with x-ray inspections at the LH2 end of the stringers following two LH2 loading operations from the launch scrub and the tanking test, but that the radius block design modification was not to be incorporated on the LH2 tank end. Another analysis objective was to determine if analytical results for the transient LH2 loading conditions bounded results for the ascent flight condition.

To expedite this effort, the existing ANSYS FE model of the LOX tank end of the stringers was modified to take advantage of the similar geometry of the stringer, skin and chord. Chord dimensions were modified as necessary to

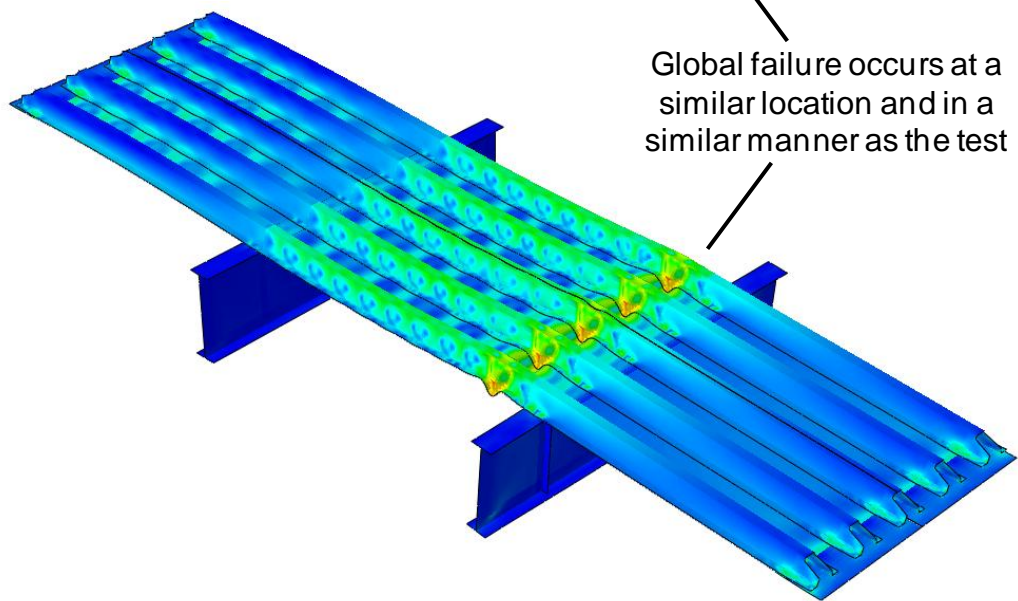
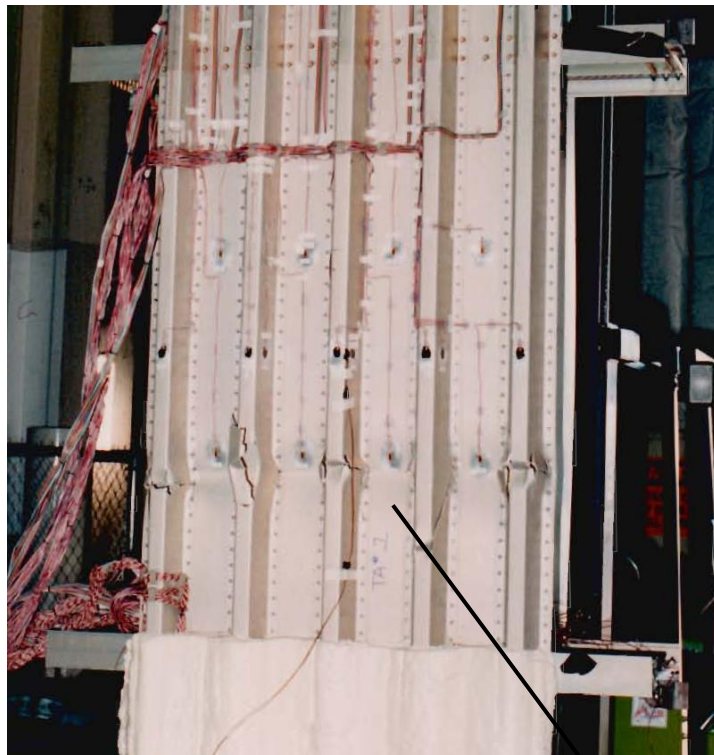

Global failure occurs at a similar location and in a similar manner as the test

Figure 25. Stringer panel compression test photograph compared to FE prediction of global stability failure (von Mises stress and deformation exaggerated 3X).

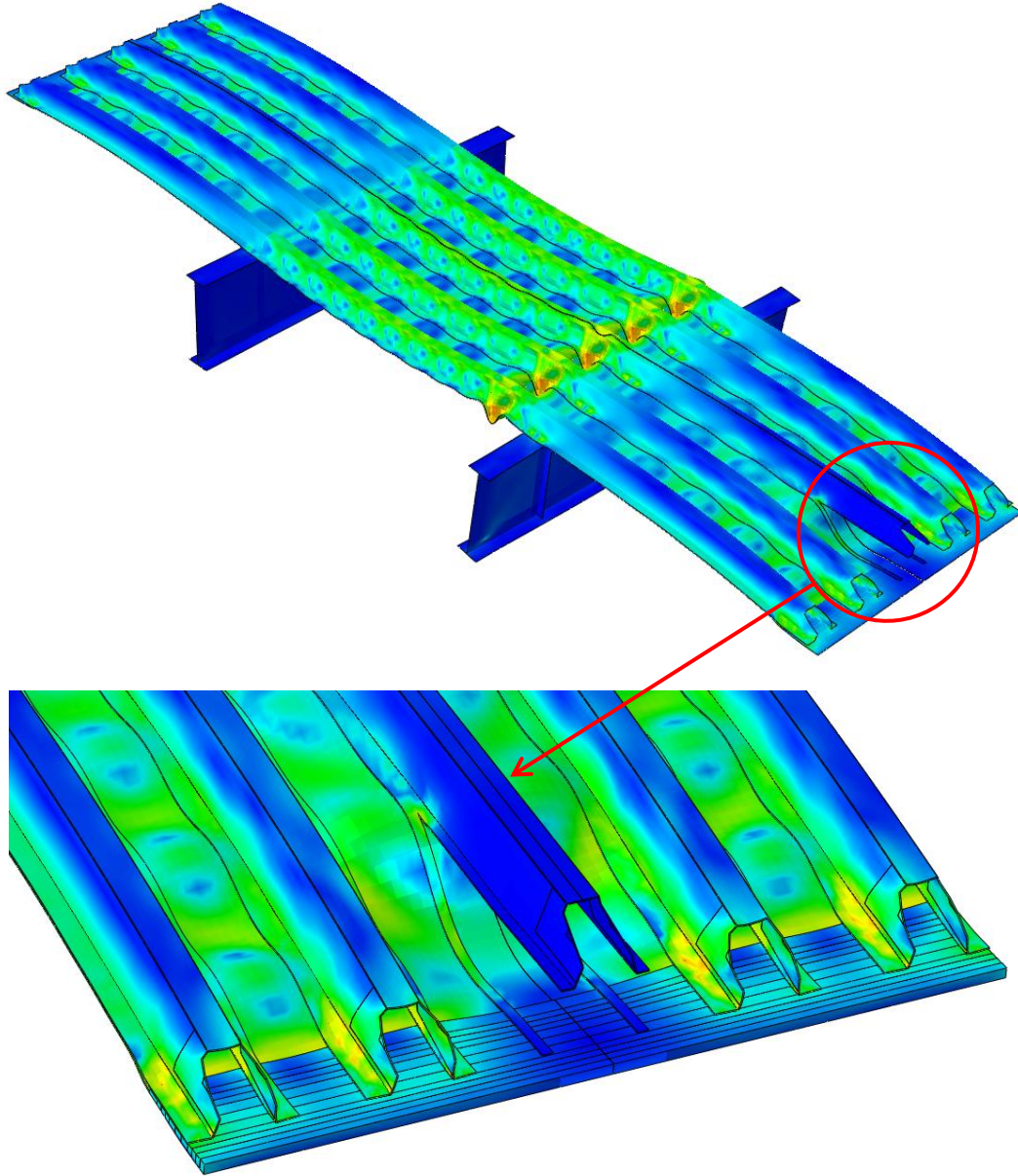

Figure 26. Example fail-safe analysis of single stringer with long cracks in both feet (von Mises stress and deformation exaggerated 5X). Note the global failure occurs at a similar location and in a similar manner as the baseline FE model with no cracked stringers.

match the design drawings. The portions of the adjacent LOX tank were replaced with portions of the adjacent LH2 tank, including the forward dome, forward ring frame, and a portion of the forward barrel. As with the other ANSYS models, this model was a half-symmetry model of one stringer (Figure 27).

Nodal temperatures were mapped onto the ANSYS structural model to evaluate several time steps within each of two transient conditions: a critical time range during LH2 propellant loading and a time range for the first 175 seconds of flight after liftoff.

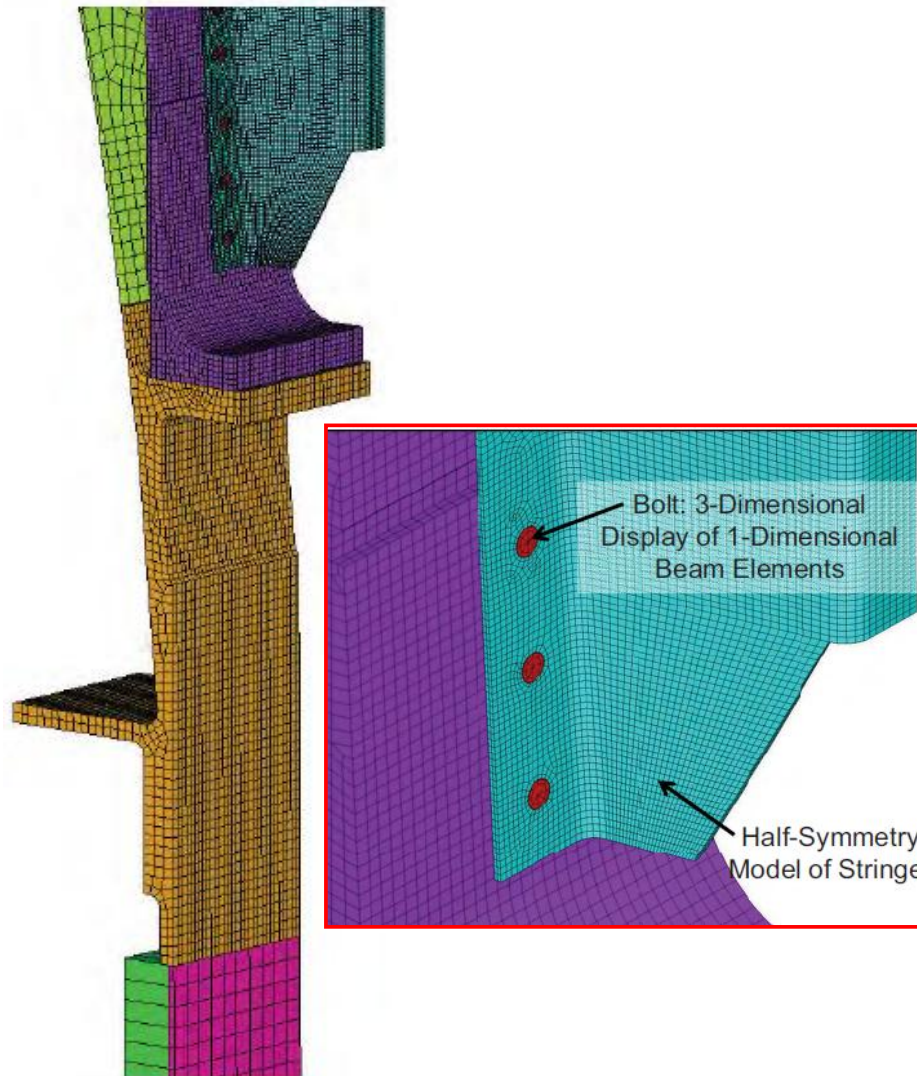

Figure 27. FE model of ET stringer near the LH2 tank.

Static analyses were performed using non-linear large deflection with stress stiffening. Material plasticity was not included. Results were obtained for stringer displacement, aft chord rotation, internal forces in the sidewall of the stringer, and stresses in the feet of the stringer (Figure 28). Four findings were drawn from this effort:

- The most limiting location/load combination in regard to the propensity for stringer cracking was determined to be at fastener location 1 for the LH2 propellant fill transient at the time of 4960 seconds. The worst case LH2 tank flange rotation, stringer tensile radial force, and stringer tensile tangential stress all occurred at this location and transient time. At this time in the fill transient, the average fastener location 1 temperature was still relatively warm at 11° F.
- The most limiting location for ascent in regard to the propensity for stringer cracking was determined to be at fastener location 3 at transient time equal to T+175 seconds. The stringer tensile radial force and stringer tensile tangential stress are approximately 14% and 8% less (respectively) than the worst case values resulting at fastener location 1 for the fill transient. However, the average temperature at fastener location 3 was still relatively cold at -254° F compared to the 11° F temperature at fastener location 1. Note that material testing by the FAT indicated a trend of decreasing fracture toughness with decreasing temperature [18]. For this reason, it could not be decisively concluded that the fill transient was a bounding event at fastener location 3. Otherwise, the fill transient was generally a bounding event, and was a significant bounding event at fastener locations 1 and 2.

- The LH2 tank fill loading condition was significantly greater in severity compared to the ascent loading for the first 2 fastener locations. For fastener locations 3 through 6, the ascent loading condition was more severe. Stringer forces and stresses at fastener locations greater than 6 were negligible relative to peak values at the other locations.
- The results indicated that the operational loading at the LH2 tank end of the stringer was significantly greater in severity compared to the LOX tank end of the stringer.

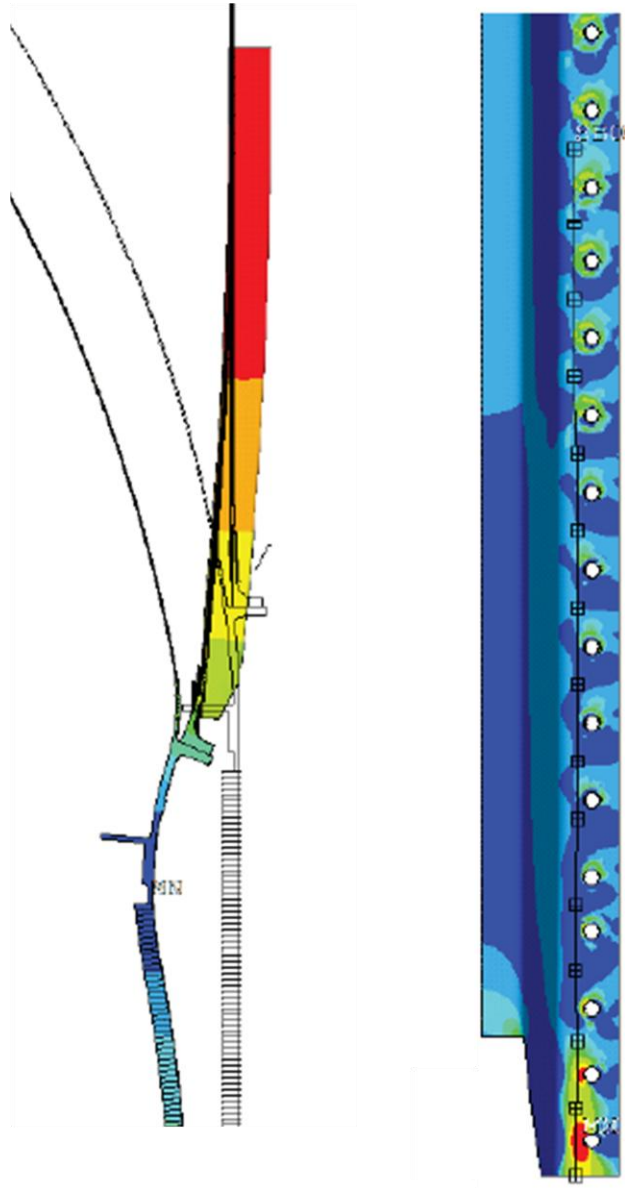

Figure 28. Example FE results for stringer radial displacement near the LH2 Tank (left) and hoop-direction stress on the under side of the stringer foot (right).

V. Root Cause and Flight Rationale

The stringer failures were concluded to be due to the material capability being less than expected and the stresses being greater than expected [19]. The reduction in material capability was attributed to the characteristic out-of-family fracture toughness behavior observed in the two suspect lots of Al-2090 stringer material from which all failed stringers were fabricated. The exact metallurgical failure phenomenon was never identified. It is important to note that the stringer material satisfied all specification acceptance requirements.

The greater than expected stresses were attributed to unexpected assembly-induced stresses that combined with stresses resulting from cryogenically-induced deflections. The specific sources and magnitudes of the assembly-induced stresses were never positively identified, although there was anecdotal evidence of several possible sources including geometric irregularities such as the toe down condition described herein, tolerance stack-up conditions resulting from the way the stringers were assembled onto the skin panels, and stresses resulting from the lockbolt installation process. A slight material under-thickness may also have contributed to higher than expected stresses. (This issue was not new and had been addressed in prior Material Review Boards.) It is important to note that the investigation found no evidence of improper workmanship or non-conforming as-built configuration.

All five stringers in which cracks were found were repaired. The remaining Al-2090 stringers were reinforced with radius blocks at the LOX end of the stringers. The SOFI at the LOX tank had to be removed prior to the mechanical installation of the radius blocks, and after all radius blocks were installed, the SOFI was reapplied and trimmed to flight configuration. Significant analysis and test efforts concluded that the radius blocks were effective in restoring the structural capability, and that they had no detrimental side effects.

There was significant concern that removing and repairing the SOFI at the LH2 tank interface in order to install radius blocks at that end of the stringers would greatly increase the risk of subsequent foam debris during ascent due to the increased risk of cryopumping in the repaired foam closeout. Also, one of the root causes of stringer failure, high assembly stresses, was concluded to be less likely to exist at the LH2 tank end of the stringers. There was anecdotal data suggesting that stringer geometric irregularities and tolerance stack-up issues were much less prevalent at the LH2 tank end. Also, no cracks had been detected at the LH2 tank end of the stringers that had been inspected. Analysis suggested that the stringer feet near the two end-most fasteners experienced their highest loading during the prelaunch transient tanking environment. Furthermore, other analyses indicated fail-safe capability against structural collapse should cracks initiate. Therefore, the Space Shuttle Program chose to leave the LH2 tank end of the stringers as-is.

The determination of the structural factor of safety presented a challenge heading into the flight readiness reviews. How to calculate the factor of safety was the source of some debate within the Shuttle community as there were differing opinions on what failure criterion to use, what material allowable to use, and what upper bound to use for assembly-induced stresses. Different methods of calculating the factor of safety were presented at the flight readiness reviews. Consensus was not obtained on any one method of calculation, but consensus was obtained that the structure was flight worthy. However, the Space Shuttle Program Requirements Control Board (PRCB) officially documented acceptance of waivers to the standard ET factor of safety requirement and to the requirement on the calculation of ultimate combined loads [20].

The final Flight Readiness Review for STS-133 was held on February 18, 2011. The flight readiness rationale was based on the main points summarized herein, but there was more in-depth discussion of the substantiating data, including the findings of Lockheed Martin, the Material FAT, and the NESC. The Review Board voted unanimously to proceed for flight. There were no dissenting opinions. STS-133 successfully launched on February 24, 2011, beginning the final mission of the Space Shuttle *Discovery* prior to decommissioning. There were no indications of ET stringer issues during prelaunch, liftoff, or ascent.

The suspect stringer material issue also affected ET-122 and ET-138, the two ETs slated to fly on the final two Space Shuttle missions, STS-134 and STS-135. Prior to the launch of STS-133, the Program had already initiated installation of the radius blocks on each of those tanks. ET-122 was ultimately concluded to have been built prior to the introduction of suspect stringer material into the production line, but by the time of that conclusion, radius block installation was completed. Both STS-134 and STS-135 successfully launched with no stringer issues.

VI. Concluding Remarks

The efforts of the MSFC stress team contributed substantially to the ET cracked stringer investigation, both in understanding the structural response of the stringers to determine failure cause and in providing data supporting the structural airworthiness of the repaired tank. By working independently of, but cooperatively with Lockheed Martin, the MSFC stress team was able to concur with their findings and recommendations. Two of the MSFC

stress team efforts were specifically requested by the NASA Space Shuttle Program Manager to be presented as part of the final STS-133 Flight Readiness Review – the ANSYS FE analysis of the stringers with and without radius blocks, and the stringer bending static load test results. The ability to design and build a test apparatus capable of re-creating the same stringer failure mode as observed on ET-137 was described by one member of the Flight Readiness Review Board as “high class innovation” [21]. The entire MSFC effort serves as a case study on the importance of maintaining a strong internal engineering capability for analysis and testing at the Center to complement the capabilities of the prime contractors.

This synopsis of the investigation highlights the efforts of only one small team within the overall investigative effort, which is not intended to diminish the importance of the large volume of work conducted by other teams and organizations such as the Material FAT, Lockheed Martin, United Space Alliance, and participating organizations within NASA. It was only through the combined efforts of all of these organizations that the Space Shuttle Program was able to safely resolve the stringer problem and complete the final shuttle missions to bring the Program to a successful end.

Acknowledgements

The author would like to gratefully acknowledge the members of the MSFC stress analysis team (Dr. Stanley Oliver, Ms. Dawn Phillips, Mr. Joe Saxon, Mr. Brian Steeve, Mr. David Harper/Boeing Huntsville Design Center, and Mr. Philip Shaw/Qualis Corp.); Mr. Wayne Gregg and Dr. Gregory Swanson of the MSFC Damage Tolerance Assessment Branch; the engineers and technicians of the MSFC Test Laboratory, particularly the Materials Environment Test Complex (METCO) Hot Gas Facility; and the engineers of Lockheed Martin Space Systems – Michoud Operations for their dedication to understanding and resolving the ET stringer issue.

References

1. Anon. (1997): *Space Shuttle External Tank System Definition Handbook, SLWT*, Volume I, Document No. LMC-ET-SE61-1, Lockheed Martin Michoud Space Systems, Contract NAS8-36200, December 1997.
2. Anon. (1995): *Critical Design Review (CDR) Super Lightweight (SLWT) External Tank*, Volume D (Design), Lockheed Martin Michoud Space Systems, Contract NAS8-36200, June 2, 1995.
3. Anon. (2004): “Tension Clip Analysis,” Lockheed Martin Michoud Space Systems Mechanical Design and Analysis Electronic Manual (analysis procedure based on Lockheed Aeronautical Systems Co. Stress Memo No. 89b, “Flange Bending Strength of Angles”).
4. G. Jerman (2010): “ET-137 Stringer 7 Preliminary Fracture Analysis,” presentation charts, Failure Analysis & Metallurgy Branch, NASA Marshall Space Flight Center, November 23, 2010.
5. G. Jerman (2010): “ET-137 Stringer 7 Fractography Update,” presentation charts, Failure Analysis & Metallurgy Branch, NASA Marshall Space Flight Center, December 9, 2010.
6. B. Steeve (2012): “STS-133 Space Shuttle External Tank Intertank Stringer Crack Investigation Stress Analysis,” paper accepted for presentation at the 53rd AIAA SDM Conference, Honolulu, HI, April 23-26, 2012, Paper No. TBD.
7. S. Sullivan (2010): “ET-137/STS-133 Tanking Test Objectives and Groundrules,” presentation to the Space Shuttle Daily Program Requirements Control Board (PRCB), Change Request/Action No. SR4866, NASA Kennedy Space Center, December 7, 2010.
8. J. Littell, T. E. Schmidt, M. Melis, S. T. Oliver, D. Revilock, C. Ruggeri, and J. Tyson (2012): “Photogrammetry Measurements During a Tanking Test on the Space Shuttle External Tank ET-137,” paper accepted for presentation at the Society for Experimental Mechanics SEM XII International Congress & Exposition on Experimental and Applied Mechanics, Costa Mesa, CA, June 11-14, 2012, Tentative Paper No. 443.
9. R. Smith (2011): *STS-133/ET-137 Instrumented Tanking Test Assessment of Strain-Gage Data*, draft test report, Lockheed Martin Michoud Space Systems, January 31, 2012.
10. S. T. Oliver (2012): “STS-133/ET-137 Tanking Test Photogrammetry Assessment,” paper accepted for presentation at the 53rd AIAA SDM Conference, Honolulu, HI, April 23-26, 2012, Paper No. TBD.
11. J. B. Saxon, G. R. Swanson, W. P. Ondocsin, T. F. Boles, and R. J. Wingate (2012): “Stringer Bending Test Helps Diagnose and Prevent Cracks in the Space Shuttle’s External Tank,” paper accepted for presentation at the 53rd AIAA SDM Conference, Honolulu, HI, April 23-26, 2012, Paper No. TBD.
12. D. R. Phillips, J. B. Saxon, and R. J. Wingate (2012): “Test-Analysis Correlation of the Single Stringer Bending Tests for the Space Shuttle ET-137 Intertank Stringer Crack Investigation,” paper accepted for presentation at the 53rd AIAA SDM Conference, Honolulu, HI, April 23-26, 2012, Paper No. TBD.

13. J. Owen, R. Wingate, B. Steeve, J. Saxon (2011): "MSFC Engineering Special PRCB," presentation to the Space Shuttle Program Requirements Control Board (PRCB), Change Request/Action No. SR4887, NASA Marshall Space Flight Center, February 16, 2011.
14. M. B. Pokrywka (1996): *Intertank Formed Skin/Stringer Panel Compression Test*, Test Report No. 826-2472, Document No. MMC-ET-SE63-4-Volume I, Lockheed Martin Manned Space Systems, July 1996.
15. D. Harper (2011): "Analysis of Intertank Formed Skin/Stringer Compression Panel Final Report," presentation charts delivered to the NASA Marshall Space Flight Center Dynamics, Loads, and Strength Branch by the Boeing Huntsville Design Center, March 29, 2011.
16. D. W. Harper and R. J. Wingate (2011): "Stability Analysis of Intertank Formed Skin/Stringer Compression Panel with Simulated Damage," unsubmitted extended abstract of proposed paper for the 53rd AIAA SDM Conference, Honolulu, HI, April 23-26, 2012.
17. P. Shaw (2011): "Structural Analysis of External Tank Intertank Stringer at Liquid Hydrogen Tank," analysis summary delivered to the NASA Marshall Space Flight Center Dynamics, Loads, and Strength Branch by Qualis Corp. of the Jacobs ESTS Group, Product ID ESTSG-FY11-00704, Task Order 32-030112-SA, May 16, 2011.
18. P. A. Allen (2011): "Al-Li 2090-T83 Fracture Test Data Summary," MSFC Materials and Processes Laboratory Flash Report No. MPFR-11-008, NASA Marshall Space Flight Center, March 24, 2011.
19. Anon. (2011): "STS-133 Delta SSP Flight Readiness Review External Tank Project," Lockheed Martin Michoud Space Systems and NASA Marshall Space Flight Center External Tank Project Office, February 11, 2011.
20. Anon. (1993): *Space Shuttle Flight and Ground System Specification, Retired Deviations/Waivers*, NSTS 0770, Volume X, Book 6, Revision L, Waiver Nos. 761 and 762 approved February 23, 2011, NASA Johnson Space Center.
21. R. J. Wingate (2011): author's notes from the STS-133 Delta Joint Shuttle/Station Flight Readiness Review held at the NASA Kennedy Space Center, February 18, 2011.