

A Change Of Inertia-Supporting the Thrust Vector Control of the Space Launch System

Adam Dziubanek
NASA, Marshall Space Flight Center, Huntsville, Alabama, 35808

Abstract

The Space Launch System (SLS) is America's next launch vehicle. To utilize the vehicle more economically, heritage hardware from the Space Transportation System (STS) will be used when possible. The Solid Rocket Booster (SRB) actuators could possibly be used in the core stage of the SLS. The dynamic characteristics of the SRB actuator will need to be tested on an Inertia Load Stand (ILS) that has been converted to Space Shuttle Main Engine (SSME). The inertia on the pendulum of the ILS will need to be changed to match the SSME inertia. In this testing environment an SRB actuator can be tested with the equivalent resistance of an SSME.

I. Introduction

An ILS is a structure used to test the dynamic characteristic of an actuator on a rocket engine. See Figure 1: Inertial Load Stand for a visual reference. The current configuration of the ILS in use at the Marshall Space Flight Center (MSFC) is designed to test a SRB actuator. An actuator is used to control the trajectory of a rocket by means of Thrust Vector Control (TVC). The pendulum on the ILS is designed to simulate the inertia of a SRB nozzle. By adding weight to the pendulum on the ILS the inertia can be made to match the SSME. The reason for changing the inertia of the pendulum is to test the dynamic characteristics of an SRB actuator on an SSME.

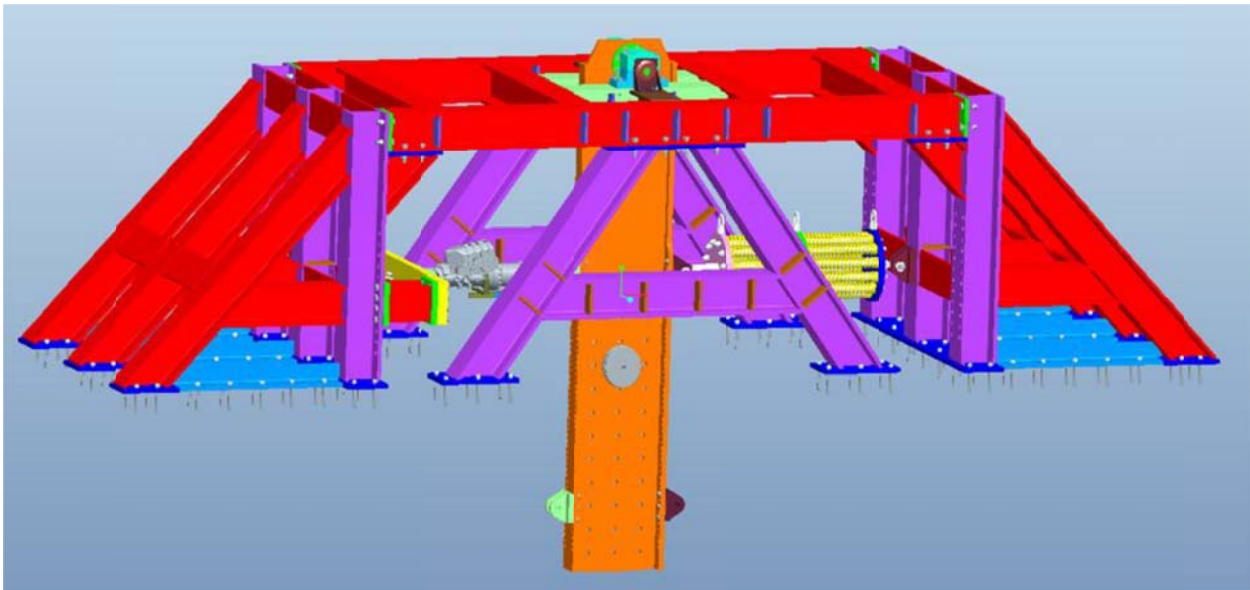

Figure 1: Inertial Load Stand

II. Supporting Information

An actuator is used to control the direction of a rocket during flight. It achieves this by moving the engine nozzle in such a way as to orient the rocket in the proper trajectory during lift off and ascent. An example of how a rocket uses Thrust Vector Control (TVC) by means of an actuator would be like trying to balance a pencil on the end of one's finger. One would have to continuously move the finger to keep the pencil in the upright position. As long as the thrust and the center of gravity of the rocket are aligned the rocket will fly straight. This is done by the gimbal movement of the rocket engine caused by the actuator. The actuator is controlled by a hydraulic fluid which pushes the piston in or out. Figure 2: SRB Actuator is an illustration. There must be two actuators connected to a rocket engine to enable full gimbaling, one for each axis of movement.

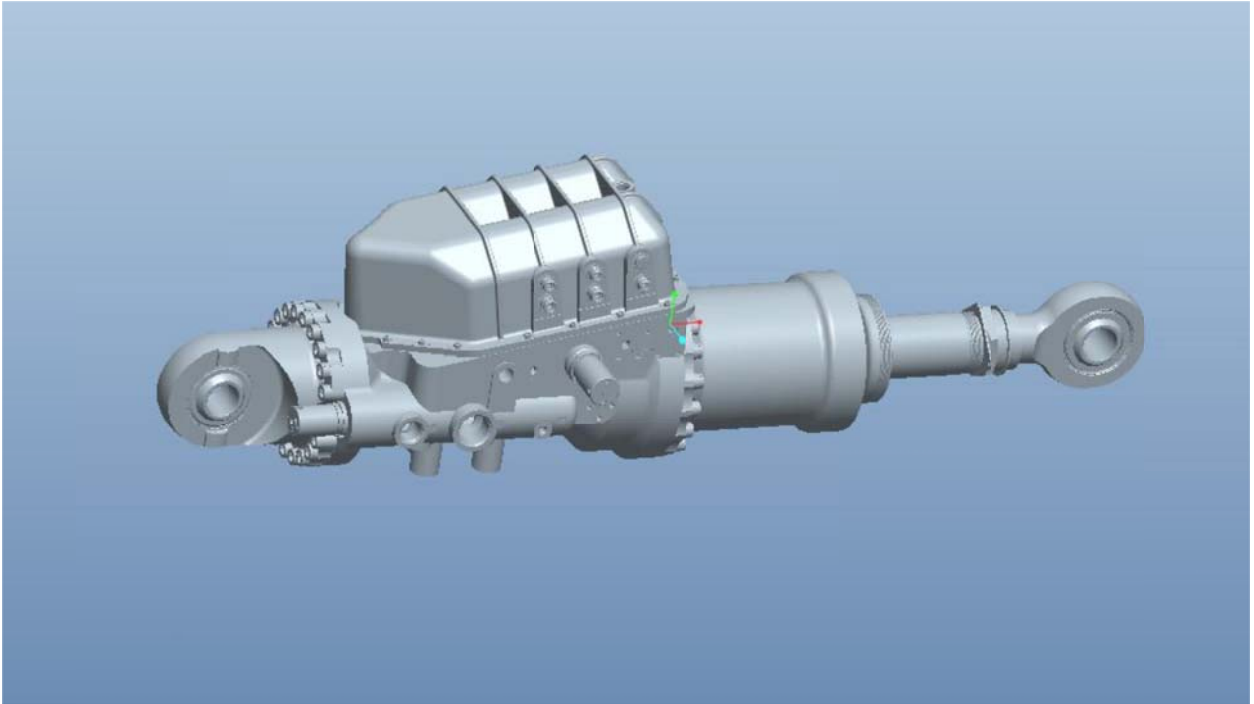

Figure 2: SRB Actuator

Figure 3: SRB Actuator Position. The actuator controls the booster's nozzle. There is a second actuator attached perpendicular to the actuator shown. The second actuator enables the booster's nozzle to move 360° in a horizontal plane. The two actuators are called "Rock" and "Tilt".

SRB Actuator

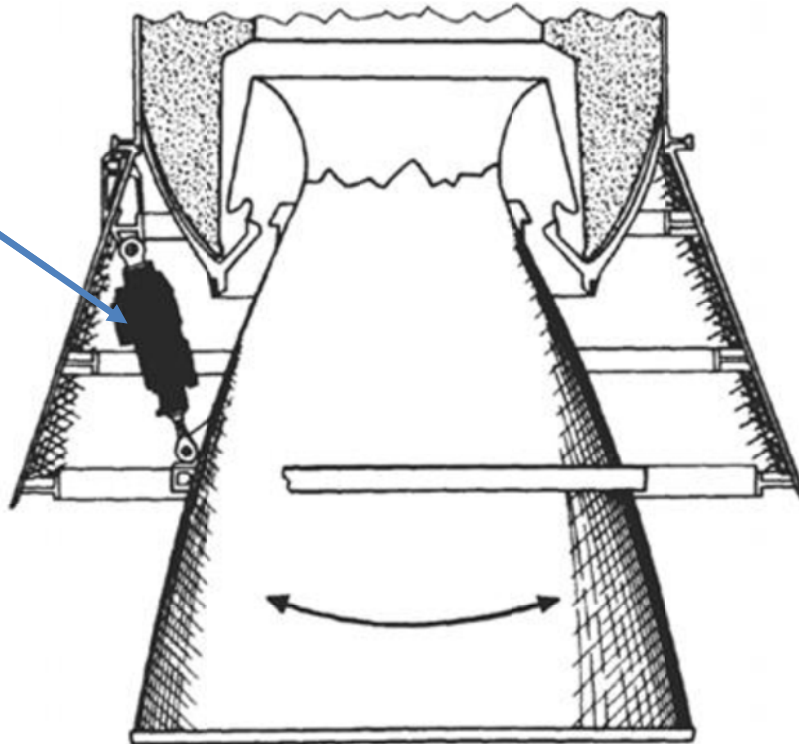

Figure 3: SRB Actuator Position

The SRB and SSME actuator are very similar except in the position of the actuator. As seen in Figure 4: SSME Actuator Positioned nearly vertically. Compare this angle to the SRB actuator in Figure 3: SRB Actuator Position. They both have very different moment arms.

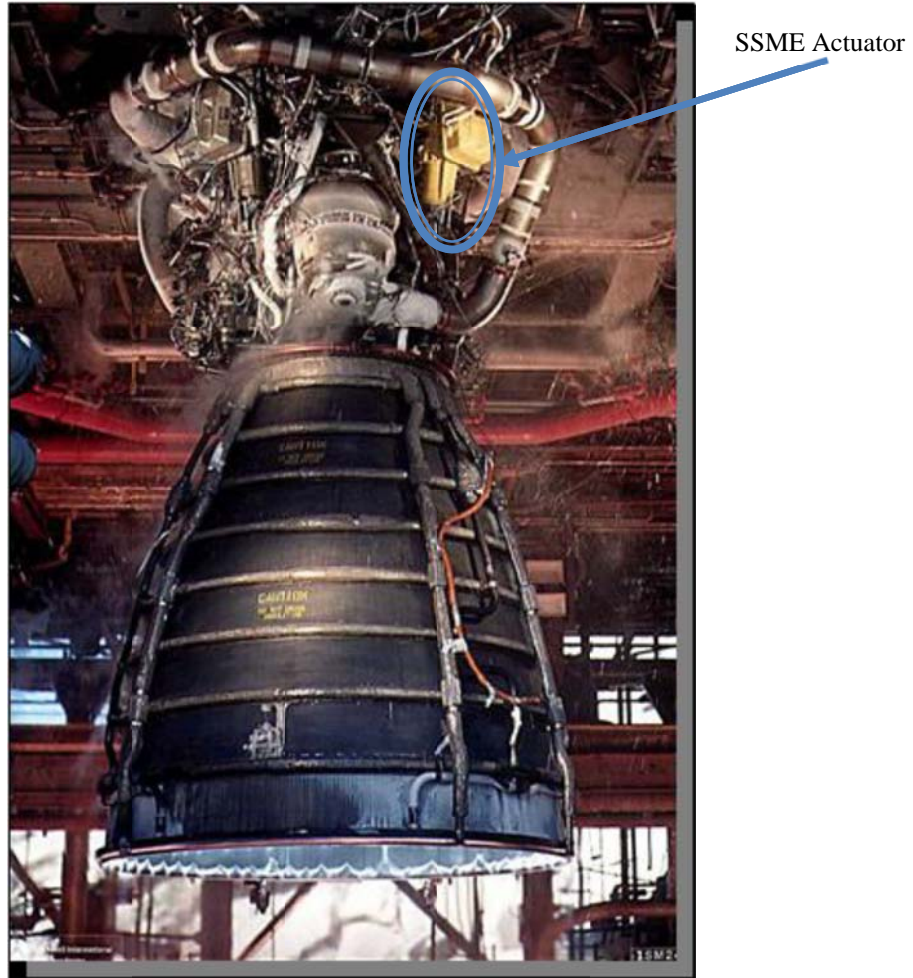

Figure 4: SSME Actuator Position

A moment arm is the distance between the pivot point of the nozzle and the perpendicular distance to the center line of the actuator. Figure 5 shows the different moment arms of the SSME and the SRB.

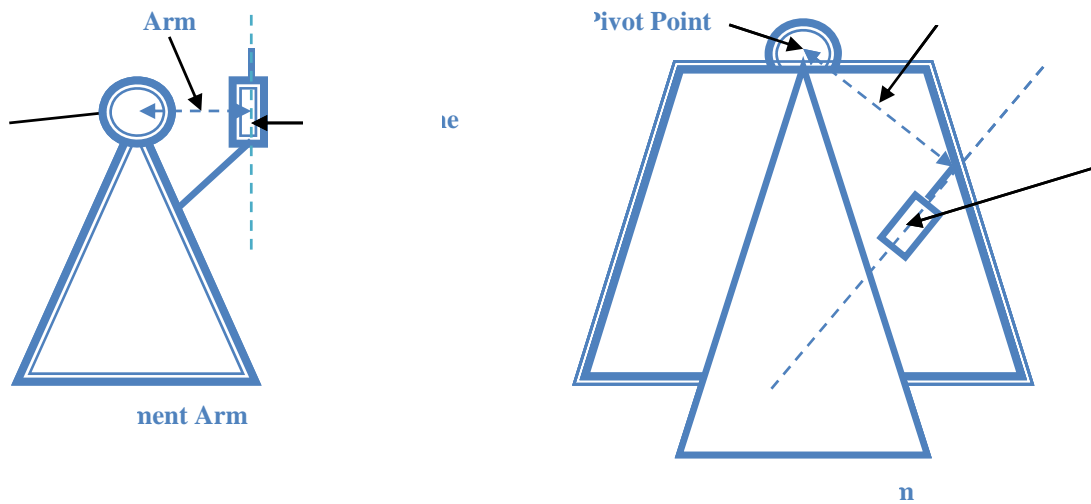

Figure: 5 Moment Arm of SSME and SRB

An ILS is used to test the dynamic characteristics of an actuator. The ILS shown in Figure 6 is a test stand designed for testing large scale actuators and consists of three primary components: the support structure, the pendulum, and the spring pack. The current pendulum configuration simulates the inertia of the SRB nozzle, while the spring pack simulates the nozzle flex bearing and flex boot equivalent stiffness.

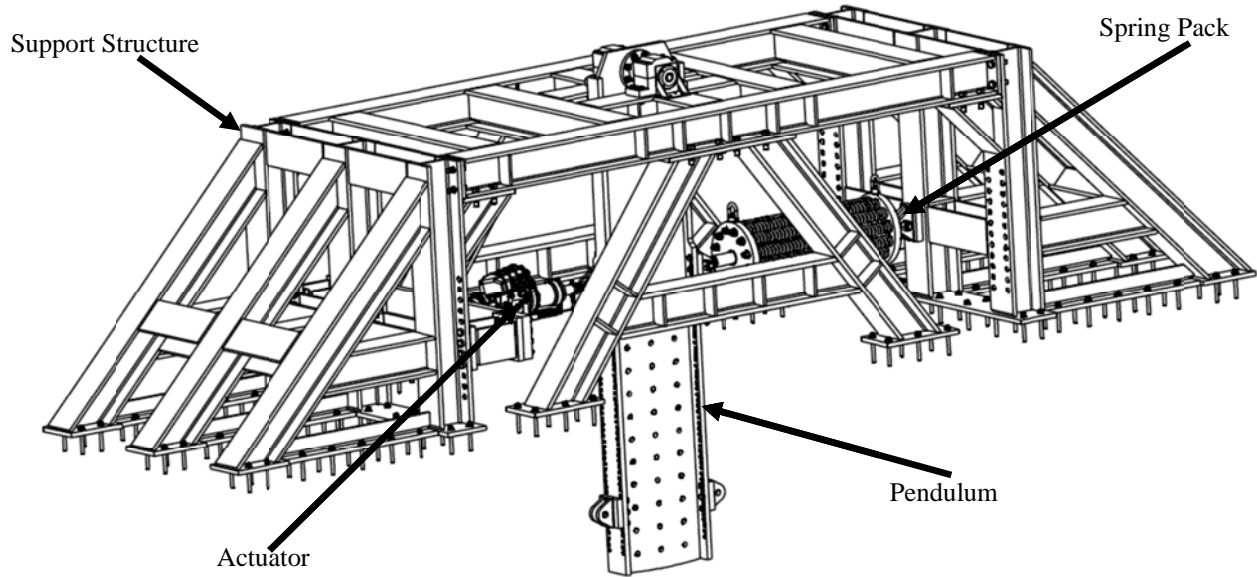

Figure 6: ILS

With the addition of weights to the pendulum the inertia can be made to match an SSME nozzle. By adding weight to the pendulum the center of gravity moves down there by changing the moment arm to match the SSME's. Figure 7 shows how weight could be added to the pendulum. A steel rod is slid through one of the holes on the pendulum and weights are added to either side of the steel rod. This is a cost savings measure as it is far less expensive to modify the current ILS rather than to build a new SSME ILS.

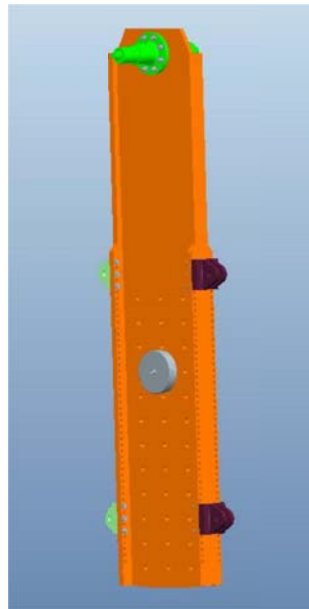

Figure7: Pendulum with weights

The SRB actuator is attached near the bottom of the rocket nozzle, and the SSME actuator is attached near the top of the rocket nozzle. To better understand the differences of the two positions think of pushing a door open. The handle on the door is located on the outer edge. This is because it requires less work to open the door because there is more leverage. The SRB actuator is positioned on the outer edge of the rocket nozzle. If one were to open the door from the inner edge it would require more work even though the distance to push the door open is less. It is much harder to open the door from the inside edge. The SSME actuator is located near the top of the rocket nozzle there by needing more work to move the nozzle compared to the SRB position. Figure 8 demonstrates the door example.

With enough weight or mass added, opening the door on the outer edge where the handle is could match the work it requires to open the door on the inside edge. This is the same principle used with the position of the actuators. Weight or mass is added to the pendulum to compensate for the extra leverage of the SRB actuator.

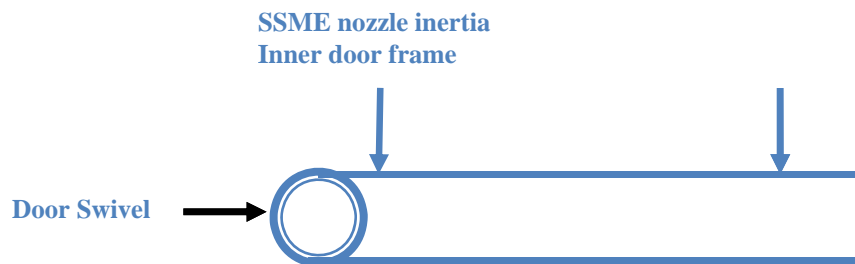

Figure 8: Door inertia example

Weights were added to the pendulum to create the proper inertia for the SRB actuator to match the SSME inertia using a spreadsheet with the inertias of both actuators and a PRO-Engineer CAD model. Figure 9 below shows the different moment arms of the SSME and the ILS pendulum.

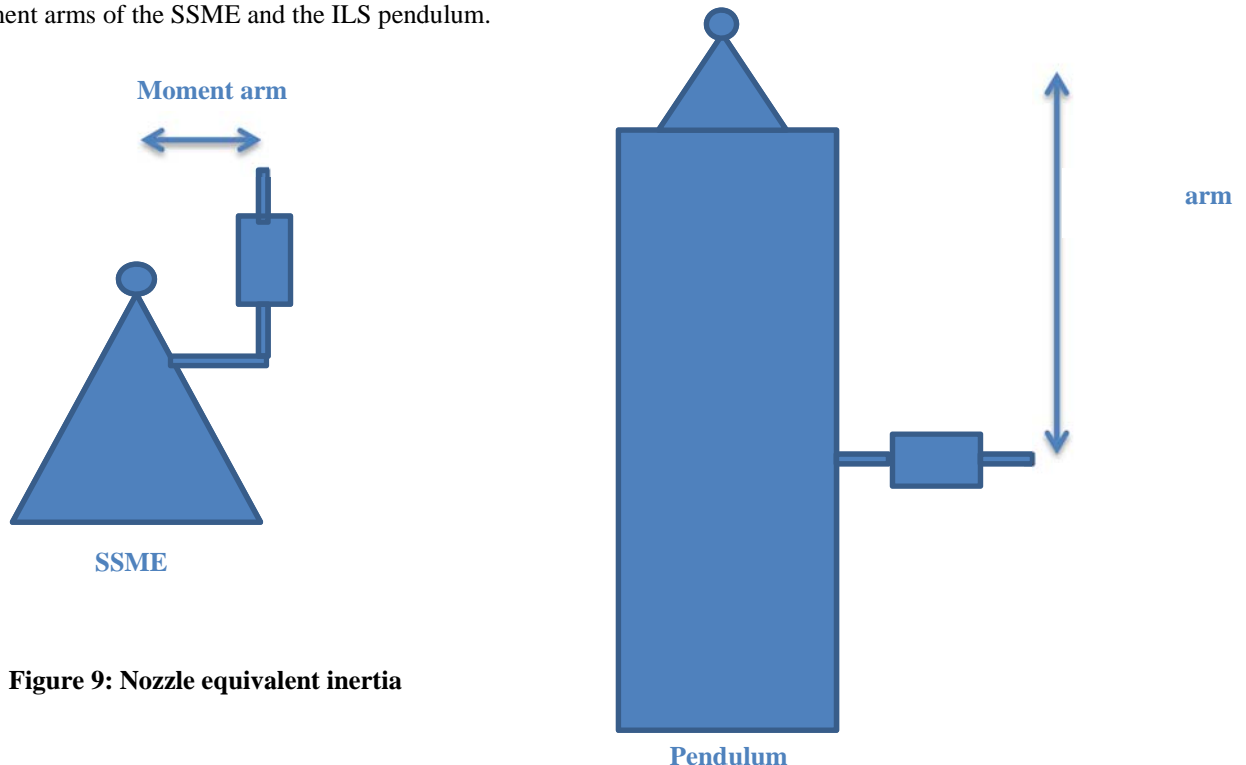

Figure 9: Nozzle equivalent inertia

Equations for Inertia Load Stand pendulum

The goal of the added inertia is to simulate a different engine configuration with the ILS test stand. It is important to take into consideration that the mass of the engine is different than the mass of the pendulum, and the engine moment arm is different than the ILS moment arm. The engine inertia was given by the engine group, and the computer program Pro Engineer (Pro/E) gave the pendulum mass, center of gravity location, and inertia about the center of gravity. See Figure 10 for location of information in Pro/E. The formulas below were used to create the necessary information for the excel spread sheet in Table 1.

$$F = ma$$

Where F= Force, m= mass, and a=acceleration

Which is equivalent to the following equation:

$$T = I\alpha$$

Where T= Torque, I= Mass Moment of Inertia, and α = Angular Acceleration

$$T = F * r$$

Where T= Torque, F= Force, and r= moment arm

$$F * r = I\alpha \Rightarrow \frac{F}{\alpha} = \frac{I}{r} \quad \leftarrow \text{Which is Consistent acceleration}$$

$$\frac{I_{MT}}{r_1} = \frac{I_{Effect}}{r_2}$$

$$I_{equivalent} = I_{Actual} \left(\frac{r_{SSME}}{r_{SRB}} \right) \quad \leftarrow \text{This is what led into the model}$$

Fixed MA

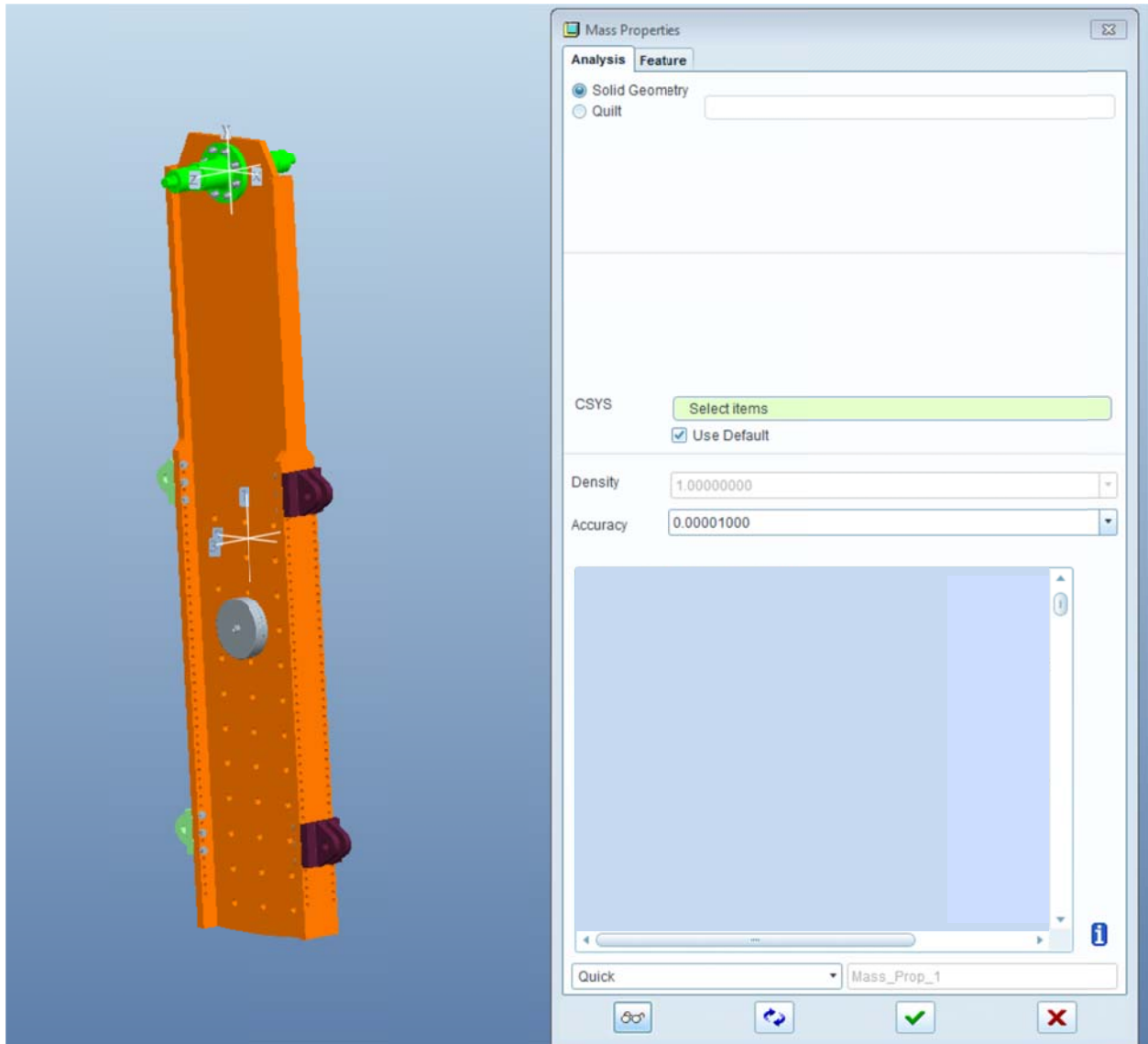

MASS = X ← Mass of pendulum in pounds. This is the first number added into the excel sheet.

CENTER OF GRAVITY = Y ← Pendulum's center of gravity. This is the second number added into the excel sheet

INERTIA TENSOR = Z ← Pendulum's moment of centroidal inertia mass property. This is the third number added to the excel

Table 1 shows the engine/nozzle equivalent of the pendulum on the ILS. The equivalent engine inertia for the pendulum was found using the Pro/E model and the spreadsheet in Table 1. Once the proper placement of the weights were found on the pendulum the appropriate information could be obtained. Equation 1 below explains how the nozzle equivalent inertia of a SSME was obtained. Equation 1 proves that the inertia of the pendulum has been converted to mirror that of a SSME.

$$\begin{aligned}
 & \text{(moment of inertia at pivot bearing)} \frac{\text{(SSME moment arm in inches)}}{\text{(Test stand moment arm in inches)}} \\
 & = \text{(Nozzle equivalent inertia)}
 \end{aligned}$$

e 1

	units	Pendulum with weight
mass	lbm	X
distance from pivot bearing to center of mass	inches	Y
Ic (moment of inertia - centroidal) mass property from Pro/E	lbm-in ²	Z
Inozeq (nozzle equivalent inertia)	in-lbf-sec ²	Similar nozzle inertia

calculated

III. Conclusion

With this new information the pendulum will match the inertia of an SSME. This project will support the threshold of a new generation of space vehicles and space explorers. With the use of the CAD modeling program, Pro Engineer, and an Excel spreadsheet the correct information was obtained, and weight was added to the pendulum to match the SSME inertia. Now the dynamic characteristics of the SRB actuator will be able to be tested on a SSME pendulum. The results of the SRB actuator on the ILS will prove it is compatible with the core stage of the SLS thereby saving NASA and the American tax payer money. Even in this difficult economy it is important to continue the exploration of space to inspire our nation to new heights.

References

This paper was created with the resources of the Marshall Space Flight Center (MSFC) in cooperation with the Co-Op education office.

Math formulas created by Chris Baker of MSFC.

Editing by Rick Maehlmann of MSFC.



SLS
Space Launch System

A Change of Inertia Supporting the Thrust Vector Control of the Space Launch System

*Adam Dziubanek
ER35, TVC Systems Integration & Component Branch
Marshall Space Flight Center*

April 2, 2012

- ◆ Modifying an Inertial Load Simulator (ILS) pendulum to match the moment arm of a Space Shuttle Main Engine (SSME)
- ◆ One possible cost saving measure will be to use Solid Rocket Booster (SRB) actuators on the Core Stage
- ◆ Use an ILS to test SRB Actuators with Core Stage engine inertia

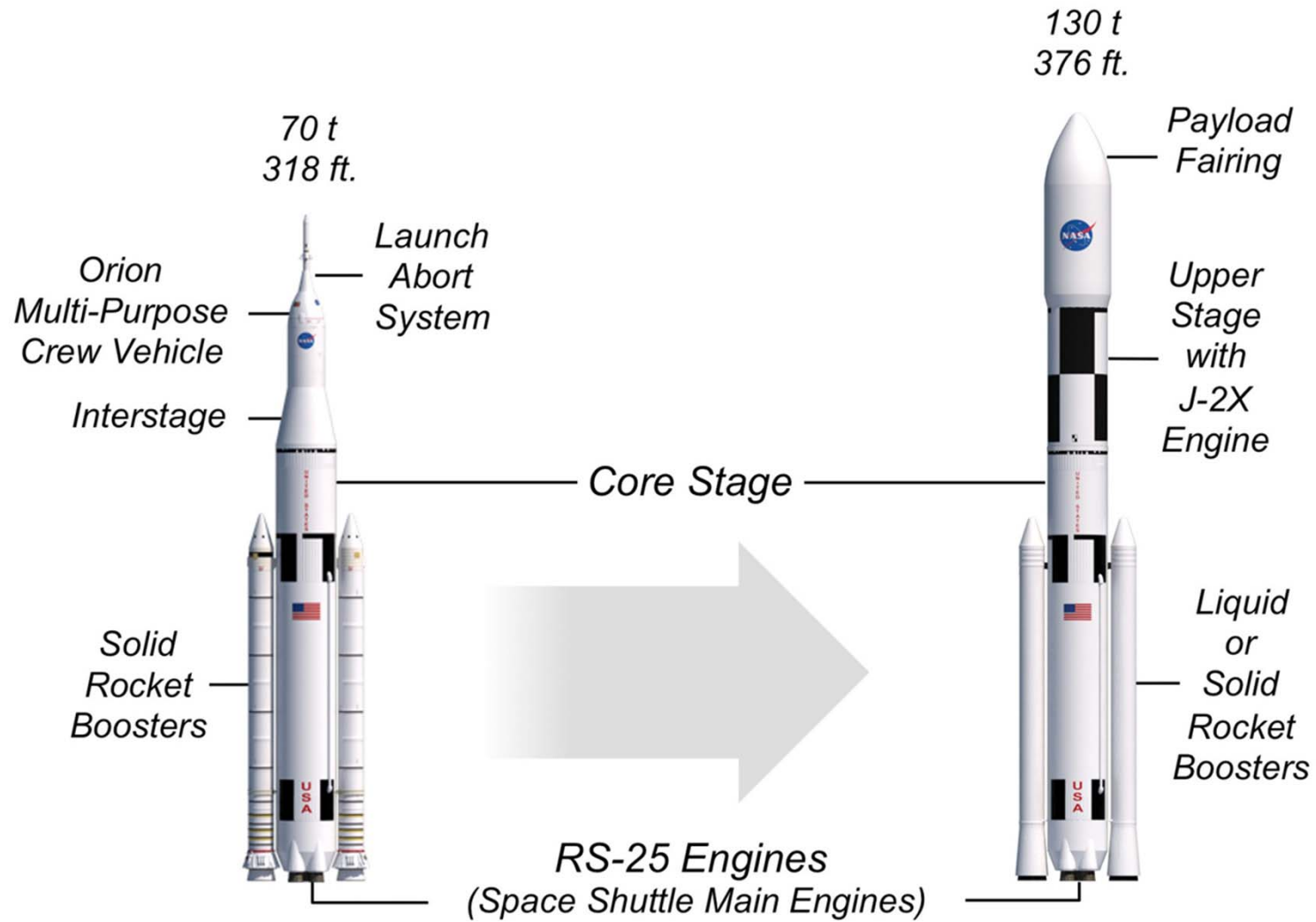

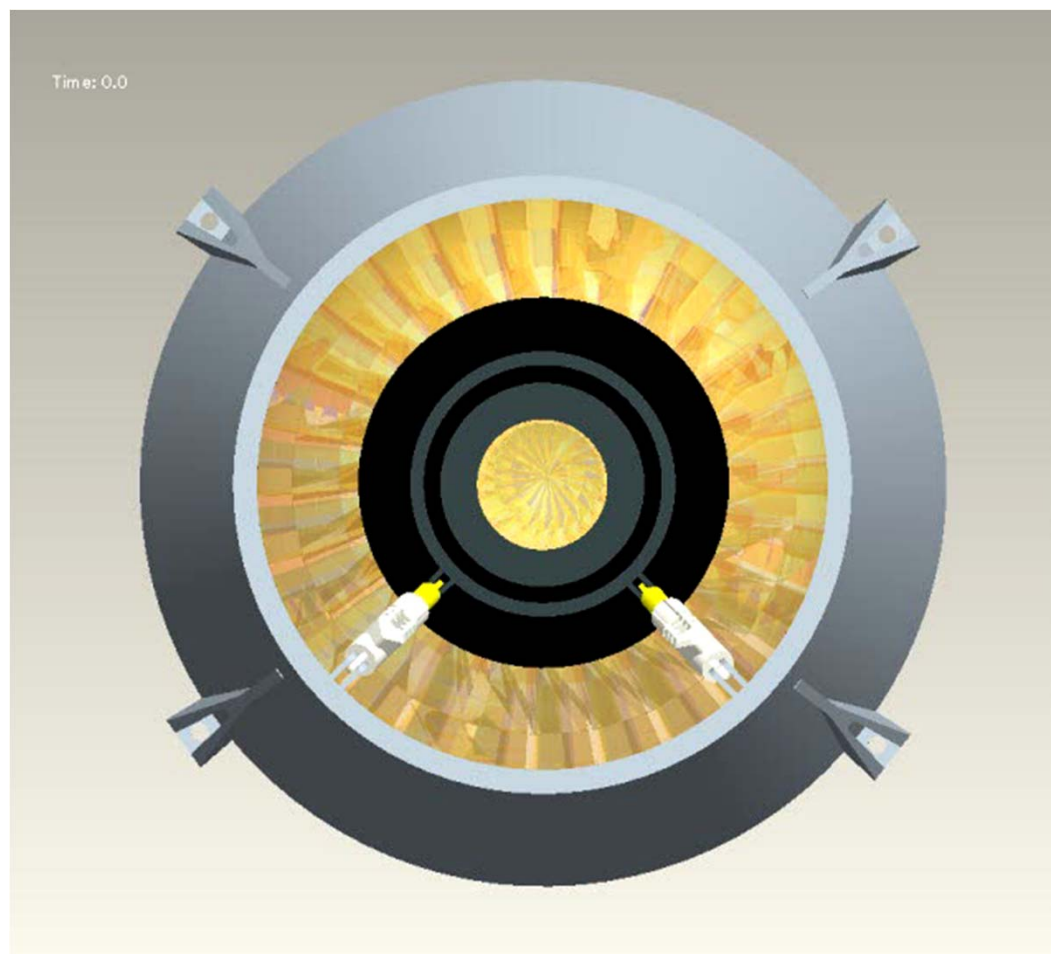

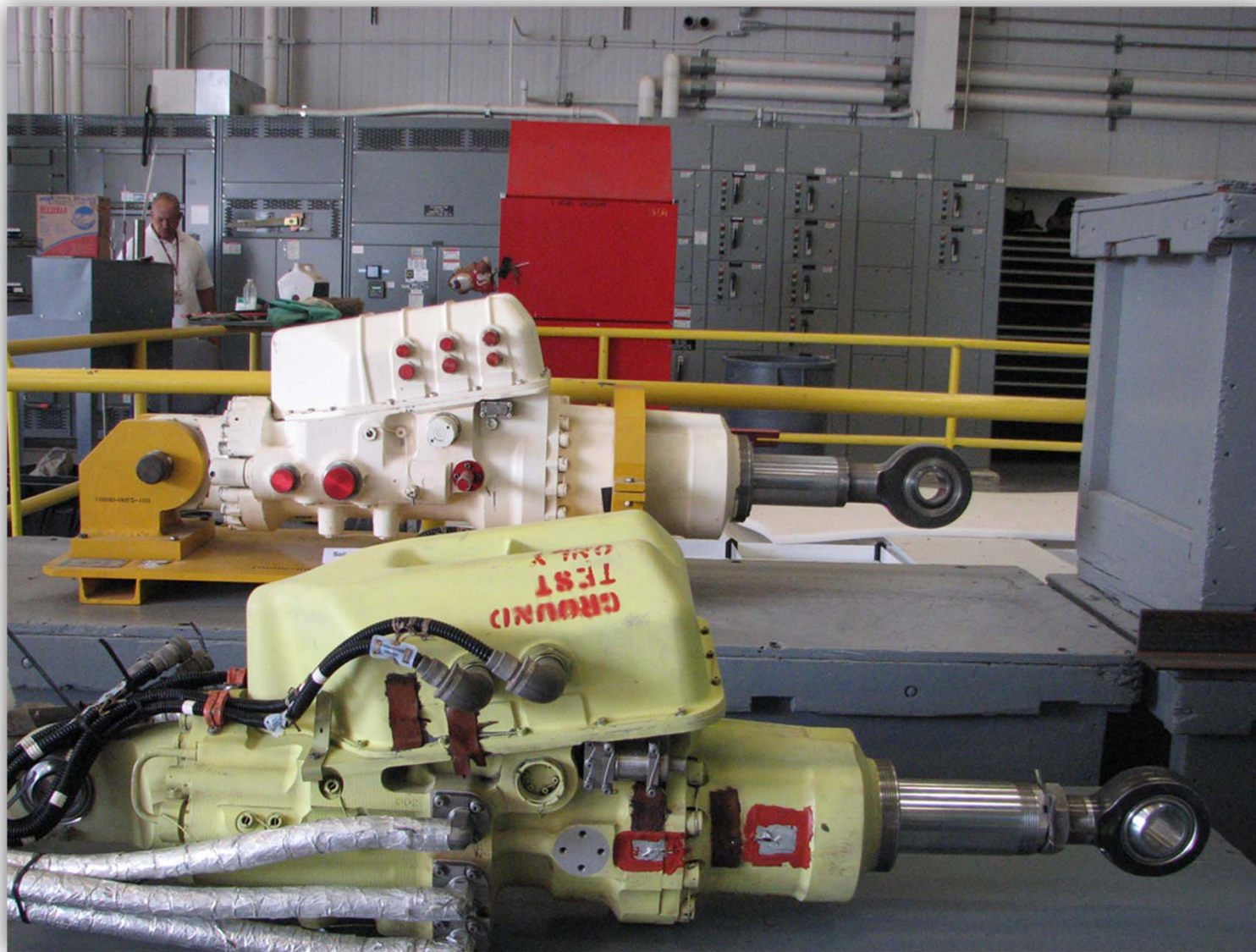



Saturn



Space Shuttle



**Space Launch System
(Proposed)**

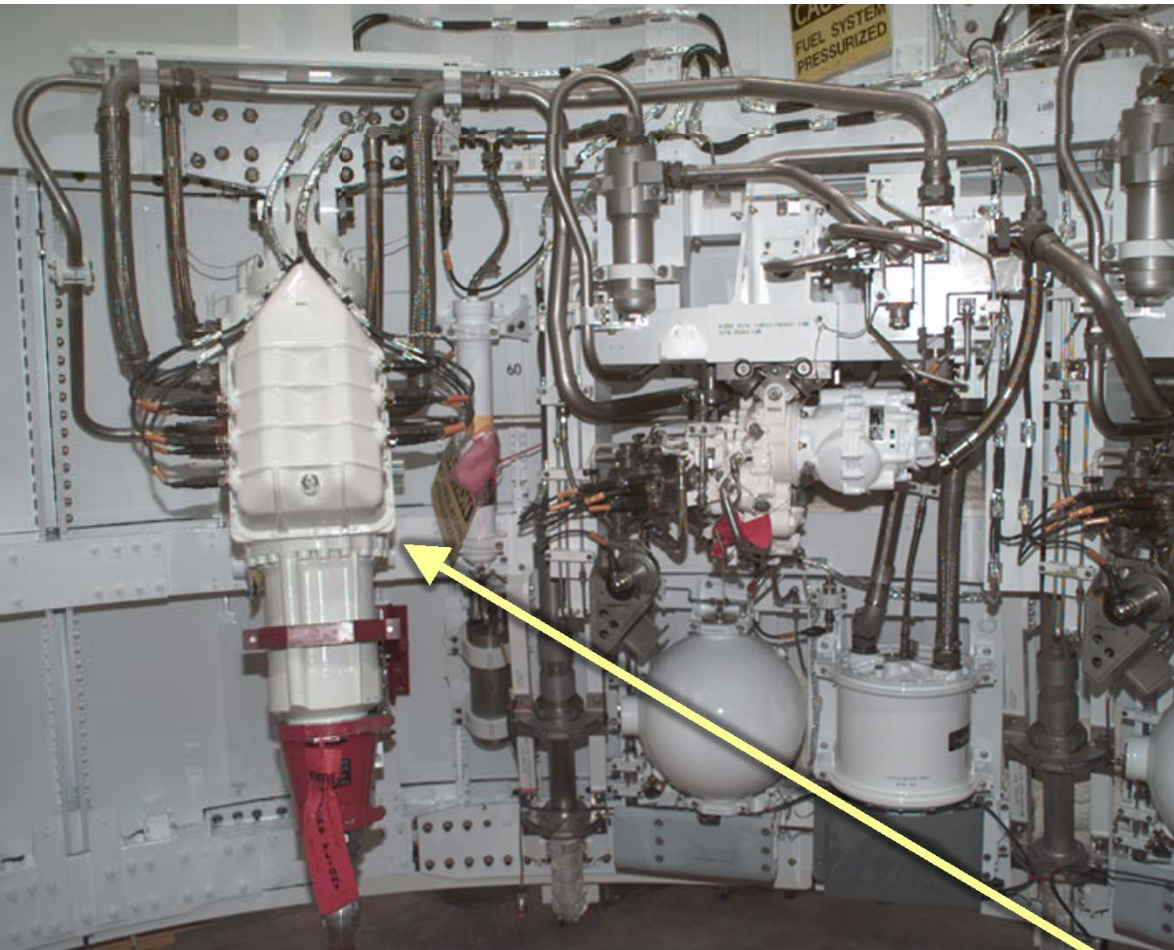

Solid Rocket Booster (SRB)

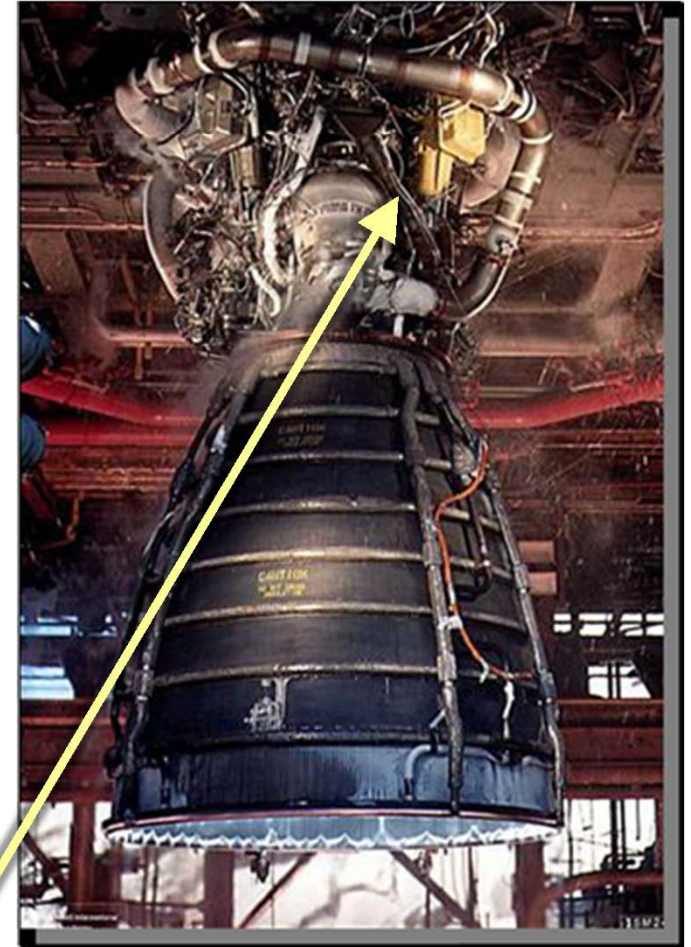

Space Shuttle Main Engine (SSME)

Actuators

**SRB
Actuator**



**SSME
Actuator**

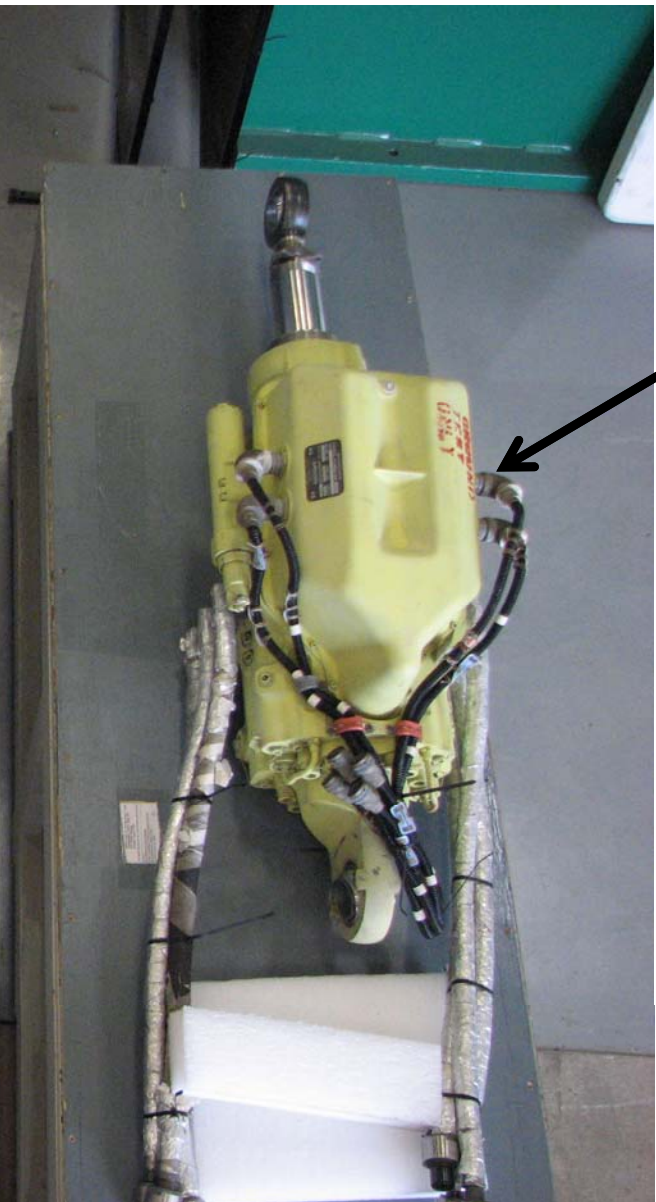

**1 SRB has
3,000,000 lbs.
of thrust**

**1 SSME has
500,000 lbs.
of thrust**

Support Structure

Spring Pack

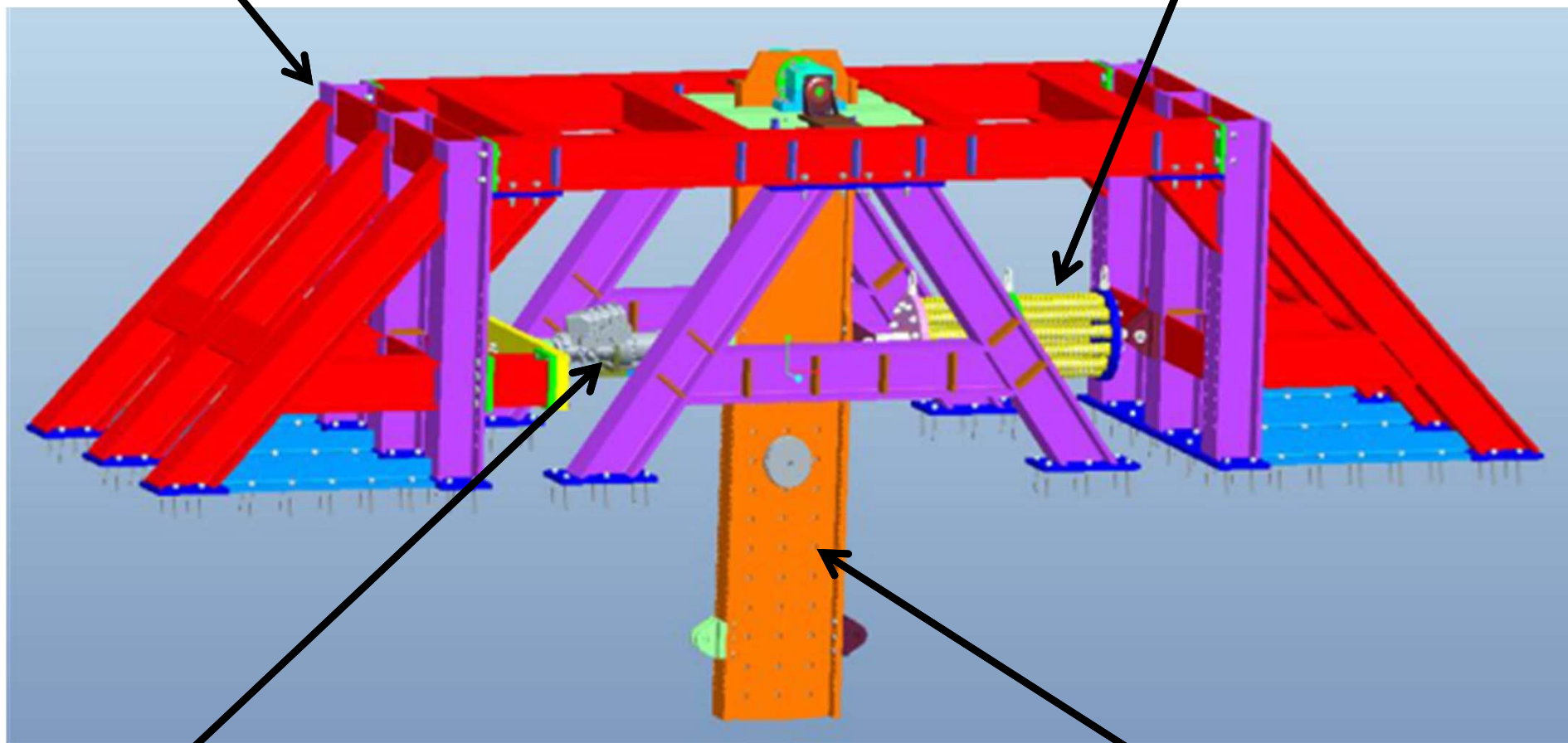

Actuator

Pendulum

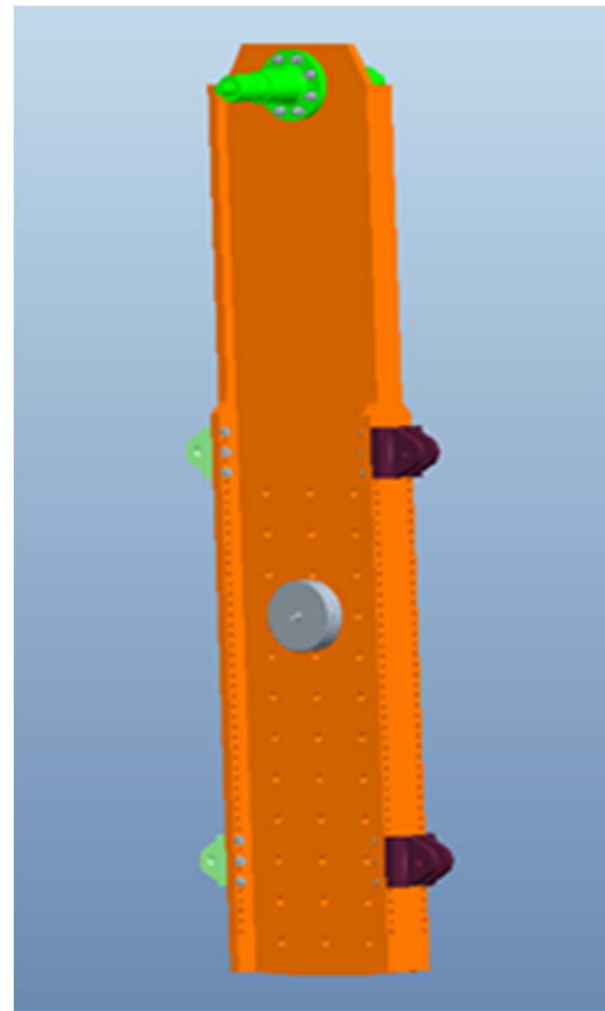
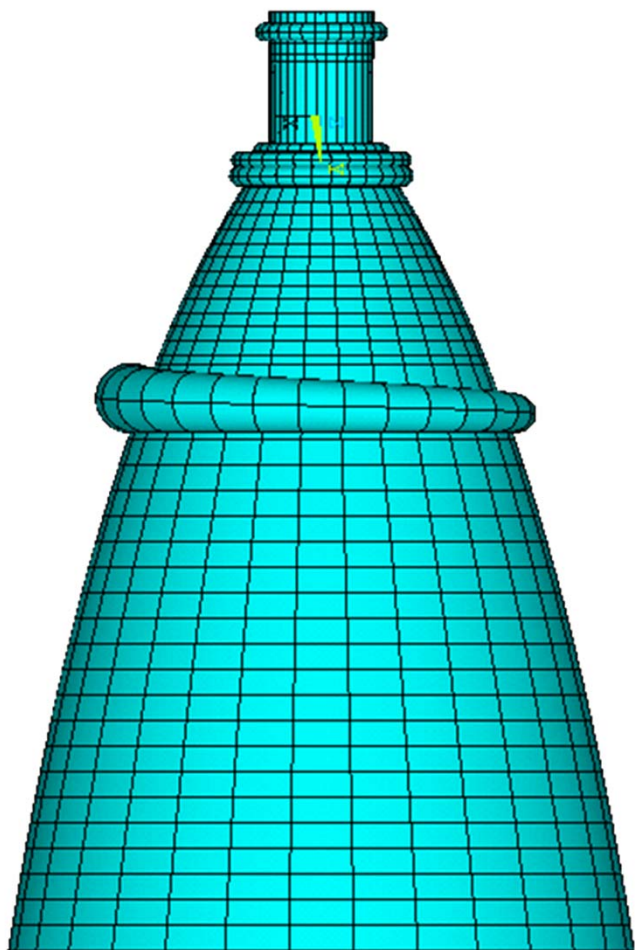

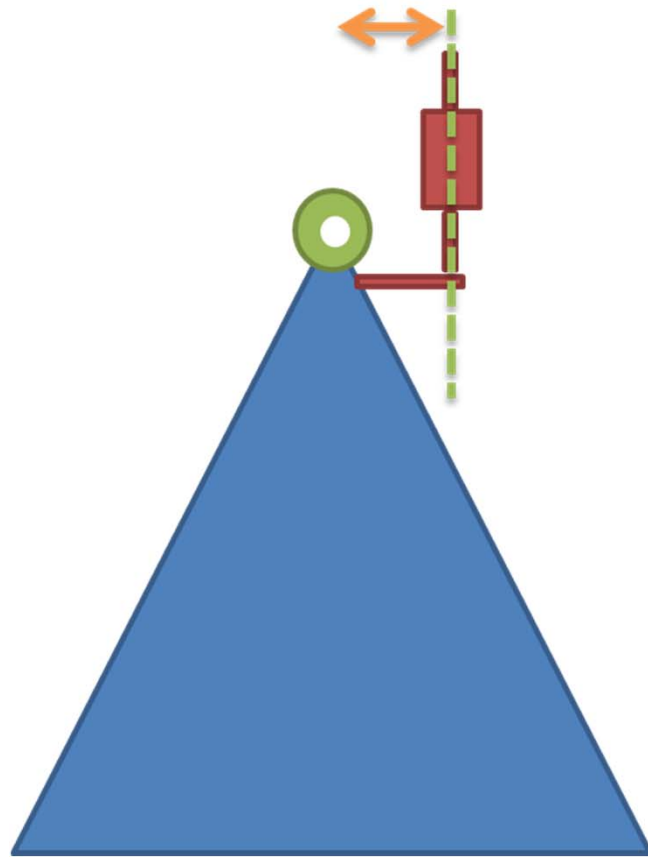

Engine Moment Arm

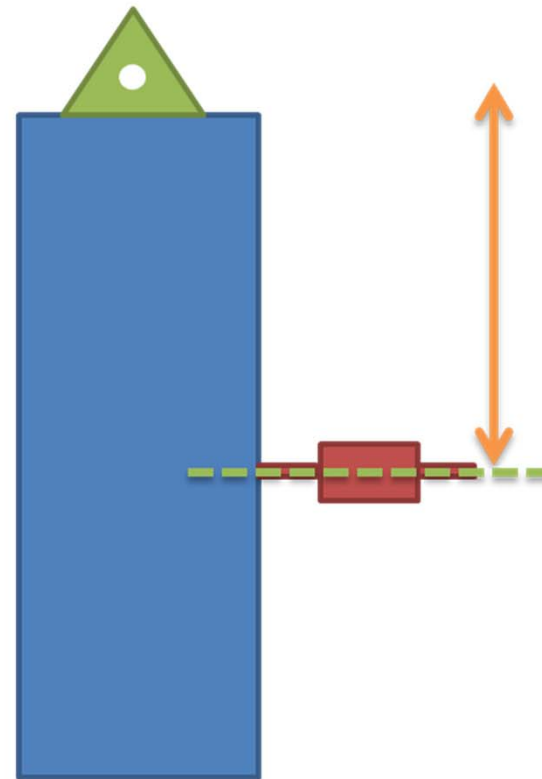

Pendulum Moment Arm

SSME INERTIA
INNER DOOR FRAME

SRB INERTIA
OUTER DOOR FRAME



- ◆ The amount of force required to open a door increases the closer the force is applied to the hinge
- ◆ If it is intended for the force to remain the same regardless of the point of application, then the inertia of the door needs to be altered

- ◆ The Moment (torque) required to move an actuator with a known moment of inertia at a given angular velocity is :

$$M = F \cdot \alpha$$

- ◆ The Moment (torque) required is also related to the amount of force output from the actuator and the location of the actuator applies that force:

$$M = F \cdot r$$

- ◆ The moment in these two equations is the same and therefore they can be set equal to each other:

$$I \cdot \alpha = M = F \cdot r$$

$$\frac{I}{r} = \frac{F}{\alpha}$$

- ◆ Assuming a constant force and angular acceleration between systems the system equations can be set equal as in the following:

$$\frac{I_{equivalent}}{r_{SSME}} = \frac{F}{\alpha} = \frac{I_{Actual}}{r_{SRB}}$$

- ◆ Finally, leading to the equation used in the model:

$$I_{equivalent} = I_{Actual} \frac{r_{SSME}}{r_{SRB}}$$

- ◆ Newton's 2nd Law of Motion: $F = ma$
 2nd rotational Law: $T = I \alpha$
- ◆ To maintain a consistent Force-to-acceleration relationship:
 Force x r = Torque

By submission: $Fr = I \alpha$ $\frac{F}{\alpha} = \frac{I}{r}$

$$\frac{I_{Pendulum}}{r_{ILS}} = \frac{I_{SSME}}{r_{SSME}} \Rightarrow I_{Pendulum} = I_{SSME} \left(\frac{r_{ILS}}{r_{SSME}} \right)$$

- ◆ Given the fixed moment arm of the test stand, the pendulum inertia required to simulate the SSME is:

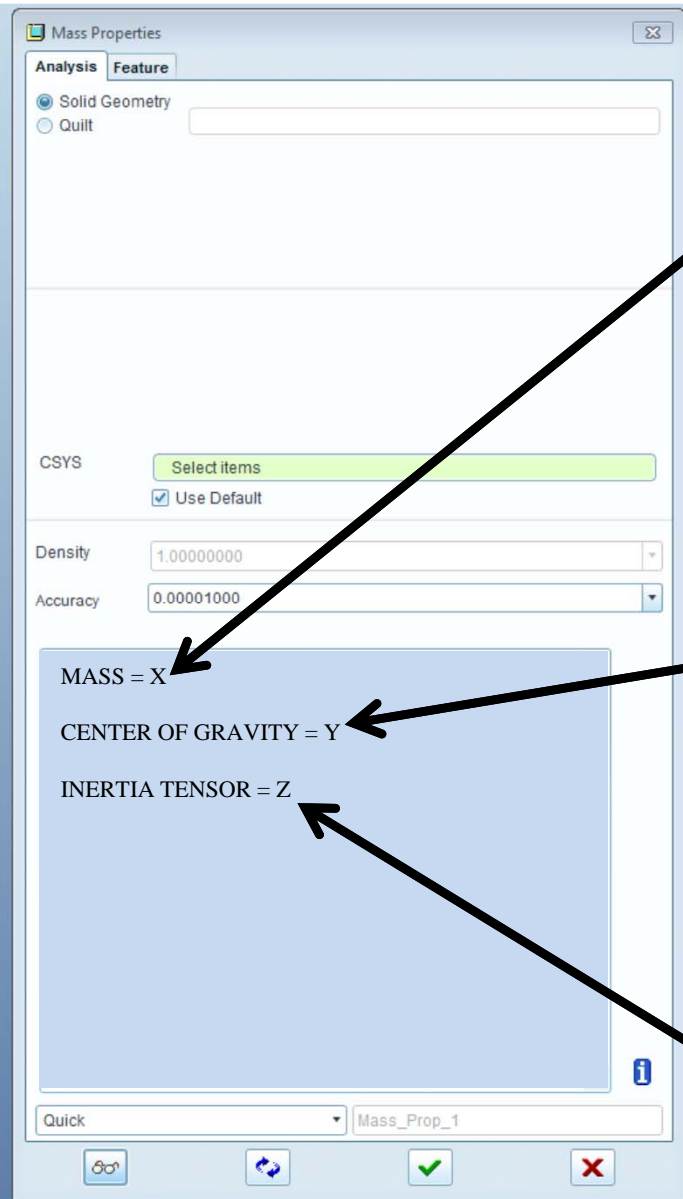
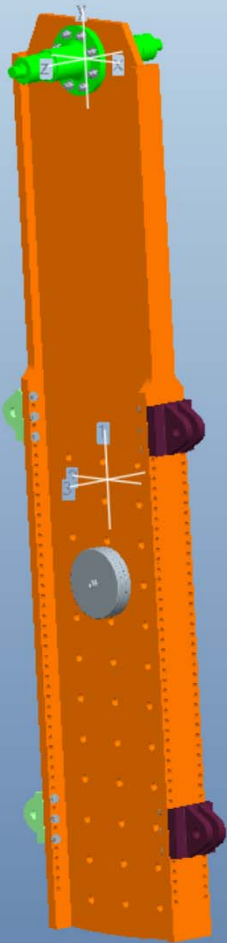

Mass of pendulum in pounds

Pendulums center of gravity

**Pendulums moment of
centroidal inertial mass
property**

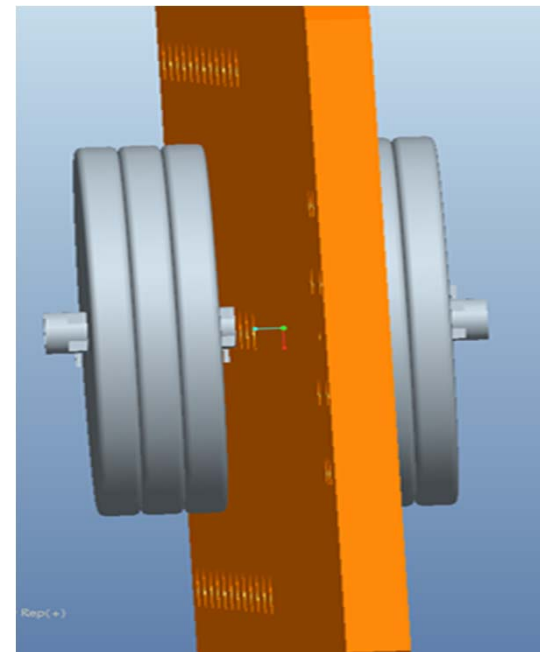
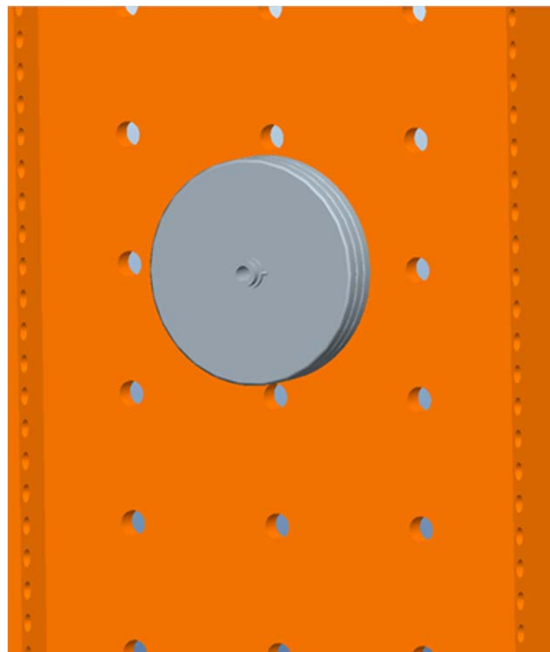
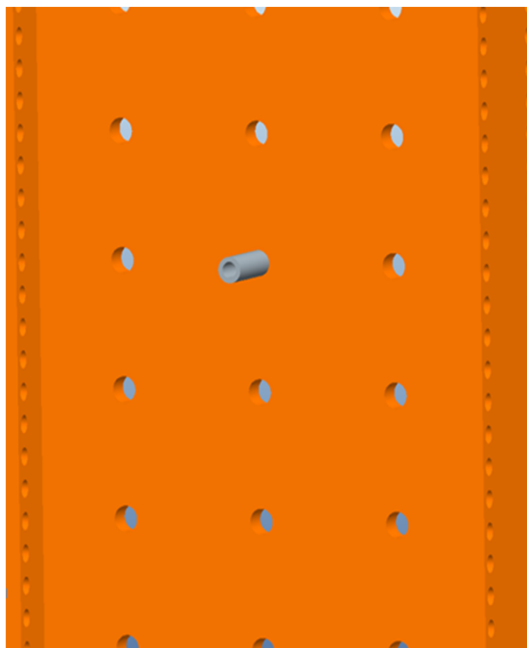

- ◆ The ILS pendulum could be modified to match the moment of inertia of a SSME
- ◆ It is possible to test an SRB actuator on the ILS

- ◆ Special thanks to Rick Maehlmann, Chris Baker, Nick Johnston, and Blake Stewart for help with the concept and design of this project
- ◆ Special thanks to the ER35 TVC group for their continued support