



National Aeronautics and
Space Administration

CxP 70024

REVISION E

RELEASE DATE: NOVEMBER 19, 2010

CONSTELLATION PROGRAM HUMAN-SYSTEMS INTEGRATION REQUIREMENTS

*Publicly Available: Release to Public Websites Requires Approval of
Chief, Office of Primary Responsibility*

Revision: E	Document No: CxP 70024
Release Date: 11/19/10	Page: 2 of 503
Title: Constellation Program Human-Systems Integration Requirements	

REVISION AND HISTORY PAGE

Revision No.	Change No.	Description	Release Date
-		Baseline (Reference CxCBD 000094/1-1, dated 12/14/06)	12/15/06
A		Revision A (Reference CxCBD 000158/1-1, dated 8/10/07)	09/26/07
	001	Change 001 (Reference CxCBD 000166/1-1, dated 10/2/07)	10/30/07
B		Revision B (Reference CxCBD 000216/2-1, dated 12/19/07) incorporates CxCBD 000114R1/1-17, dated 7/13/07; CxCBD 000123R1/1-15, dated 7/13/07; and CAR 000094, dated 11/26/07	03/03/08
C		Revision C (Reference CxCBD 000260/1-1, dated 10/28/08) incorporates CxCBD 000288, dated 8/25/08 and CAR 000288, dated 01/09/09	03/06/09
D		Revision D (Reference CxCBD 000399R1/1-1, dated 12/09/09) Also incorporates changes approved by CAR 000357 and CxCBD 000389	12/11/09
E		Revision E (Reference CxCBD 000470/6-1, dated 09/27/10)	11/19/10

Revision: E	Document No: CxP 70024
Release Date: 11/19/10	Page: 3 of 503
Title: Constellation Program Human-Systems Integration Requirements	

TABLE OF CONTENTS

SECTION	PAGE
1 INTRODUCTION	12
1.1 PURPOSE	12
1.2 SCOPE AND PRECEDENCE	12
1.3 IMPLEMENTATION	13
1.4 CHANGE AUTHORITY/RESPONSIBILITY	13
2 DOCUMENTS	13
2.1 APPLICABLE DOCUMENTS.....	13
2.2 REFERENCE DOCUMENTS	16
3 HUMAN-SYSTEMS REQUIREMENTS.....	22
3.1 ANTHROPOMETRY, BIOMECHANICS, AND STRENGTH.....	22
3.1.1 Anthropometry.....	22
3.1.2 Range of Motion	23
3.1.3 Mass Properties	24
3.1.4 Strength.....	25
3.2 NATURAL AND INDUCED ENVIRONMENTS.....	26
3.2.1 Atmosphere.....	26
3.2.2 Potable Water.....	38
3.2.3 Thermal Environment	47
3.2.4 Acceleration.....	52
3.2.5 Vibration	63
3.2.6 Acoustics.....	65
3.2.7 Ionizing Radiation.....	73
3.2.8 Non-Ionizing Radiation (NIR).....	78
3.3 SAFETY	83
3.3.1 Emergency Equipment Access.....	83
3.3.2 Mechanical Hazards.....	83
3.3.3 Electrical Hazards.....	85
3.3.4 Touch Temperature Limits.....	87
3.3.5 Fire Suppression Portability.....	88

Revision: E	Document No: CxP 70024
Release Date: 11/19/10	Page: 4 of 503
Title: Constellation Program Human-Systems Integration Requirements	

SECTION	PAGE
3.4 ARCHITECTURE	88
3.4.1 Configuration	88
3.4.2 Translation Paths	90
3.4.3 Restraints and Mobility Aids	91
3.4.4 Hatches	92
3.4.5 Windows.....	95
3.4.6 Lighting.....	98
3.5 CREW FUNCTIONS.....	102
3.5.1 Food Preparation.....	102
3.5.2 Personal Hygiene	106
3.5.3 Body Waste Management	107
3.5.4 Exercise	115
3.5.5 Space Medicine.....	116
3.5.6 Stowage	121
3.5.7 Trash Management	122
3.6 CREW INTERFACES.....	123
3.6.1 General	123
3.6.2 Crew Performance.....	125
3.6.3 Display and Control Layout.....	127
3.6.4 Displays.....	130
3.6.5 Hardware and Software Controls.....	132
3.6.6 Crew Notifications and Caution and Warning.....	135
3.6.7 Crew-System Interaction	137
3.6.8 Electronic Procedures	138
3.7 MAINTENANCE AND HOUSEKEEPING.....	139
3.7.1 Maintenance.....	140
3.7.2 Housekeeping	147
3.8 INFORMATION MANAGEMENT	148
3.8.1 Crew Operability.....	149
3.8.2 Data Available	149
3.8.3 Data Distribution.....	149
3.8.4 Data Backup.....	150

Revision: E	Document No: CxP 70024
Release Date: 11/19/10	Page: 5 of 503
Title: Constellation Program Human-Systems Integration Requirements	

SECTION	PAGE
3.9	GROUND MAINTENANCE AND ASSEMBLY 150
3.9.1	Ground Anthropometry, Biomechanics, and Strength 151
3.9.2	Ground Natural and Induced Environments 151
3.9.3	Ground Safety 151
3.9.4	Ground Architecture 152
3.9.5	Ground Crew Functions 153
3.9.6	Ground Crew Interfaces 153
3.9.7	Launch Site Processing and Ground Maintenance 156
3.9.8	Ground Information Management 163
3.10	EXTRAVEHICULAR ACTIVITY (EVA) 163
3.10.1	Suit Atmosphere 163
3.10.2	Suited Visibility 167
3.10.3	Crew Functions for the Suited Crewmember 167
3.10.4	Prevention and Treatment of Decompression Sickness 170
3.10.5	Data for Physiological Parameters 176
4	HUMAN-SYSTEMS VERIFICATION REQUIREMENTS 180
4.1	ANTHROPOMETRY, BIOMECHANICS, AND STRENGTH 180
4.1.1	Anthropometry 180
4.1.2	Range of Motion 181
4.1.3	Mass Properties 182
4.1.4	Strength 183
4.2	NATURAL AND INDUCED ENVIRONMENTS 185
4.2.1	Atmosphere 185
4.2.2	Potable Water 193
4.2.3	Thermal Environment 198
4.2.4	Acceleration 202
4.2.5	Vibration 206
4.2.6	Acoustics 208
4.2.7	Ionizing Radiation 217
4.2.8	Non-Ionizing Radiation (NIR) 222
4.3	SAFETY 227
4.3.1	Emergency Equipment Access 227

Revision: E	Document No: CxP 70024
Release Date: 11/19/10	Page: 6 of 503
Title: Constellation Program Human-Systems Integration Requirements	

SECTION	PAGE
4.3.2	Mechanical Hazards 227
4.3.3	Electrical Hazards..... 229
4.3.4	Touch Temperature Limits..... 230
4.3.5	Fire Suppression Portability 237
4.4	ARCHITECTURE 237
4.4.1	Configuration 237
4.4.2	Translation Paths 238
4.4.3	Restraints and Mobility Aids 239
4.4.4	Hatches 240
4.4.5	Windows..... 243
4.4.6	Lighting..... 247
4.5	CREW FUNCTIONS..... 249
4.5.1	Food Preparation..... 249
4.5.2	Personal Hygiene 250
4.5.3	Body Waste Management 251
4.5.4	Exercise 255
4.5.5	Space Medicine..... 257
4.5.6	Stowage 260
4.5.7	Trash Management 262
4.6	CREW INTERFACES..... 263
4.6.1	General 263
4.6.2	Crew Performance..... 264
4.6.3	Display and Control Layout..... 268
4.6.4	Displays..... 270
4.6.5	Hardware and Software Controls..... 272
4.6.6	Crew Notifications and Caution and Warning..... 275
4.6.7	Crew-System Interaction 277
4.6.8	Electronic Procedures 278
4.7	MAINTENANCE AND HOUSEKEEPING..... 280
4.7.1	Maintenance..... 280
4.7.2	Housekeeping 286
4.8	INFORMATION MANAGEMENT 287

Revision: E	Document No: CxP 70024
Release Date: 11/19/10	Page: 7 of 503
Title: Constellation Program Human-Systems Integration Requirements	

SECTION	PAGE
4.8.1 Crew Operability	287
4.8.2 Data Available	287
4.8.3 Data Distribution	288
4.8.4 Data Backup	289
4.9 GROUND MAINTENANCE AND ASSEMBLY	289
4.9.1 Ground Anthropometry, Biomechanics, and Strength	289
4.9.2 Ground Natural and Induced Environments	289
4.9.3 Ground Safety	289
4.9.4 Ground Architecture	290
4.9.5 Ground Crew Functions	290
4.9.6 Ground Crew Interfaces	290
4.9.7 Launch Site Processing and Ground Maintenance	292
4.9.8 Ground Information Management	298
4.10 EXTRAVEHICULAR ACTIVITY (EVA)	298
4.10.1 Suit Atmosphere	298
4.10.2 Suited Visibility	301
4.10.3 Crew Functions for the Suited Crewmember	302
4.10.4 Prevention and Treatment of Decompression Sickness	303
4.10.5 Data for Physiological Parameters	304

APPENDIX

A	ACRONYMS AND ABBREVIATIONS AND GLOSSARY OF TERMS	306
B	ANTHROPOMETRY, BIOMECHANICS, AND STRENGTH	326
C	NATURAL AND INDUCED ENVIRONMENTS	383
D	SAFETY	393
E	THERMAL COMFORT AND METABOLIC LOADS	394
F	BLANK	403
G	BLANK	404
H	TBD LIST	405
I	TBR LIST	406
J	BLOCK 0 (ORION 1) DRM ALLOCATION MATRIX	407

Revision: E	Document No: CxP 70024
Release Date: 11/19/10	Page: 8 of 503
Title: Constellation Program Human-Systems Integration Requirements	

APPENDIX	PAGE
J BLOCK 0 (ORION 2) DRM ALLOCATION MATRIX.....	420
J BLOCK 1 (FULLY FUNCTIONAL ISS) DRM ALLOCATION MATRIX.....	436
J BLOCK 2 (EXO-LEO/LUNAR) DRM ALLOCATION MATRIX.....	451
K CREW INTERFACES.....	472
L NIOSH LIFTING EQUATION.....	478
M WINDOW VIEW OBSTRUCTION KEEP-OUT ZONES.....	483
N OCCUPANT PROTECTION.....	486

TABLE	
3.1.3.1-1 TOTAL CREW CONTROL MASS.....	24
3.2.1.2.1-1 PHYSIOLOGICAL TOTAL PRESSURE LIMITS FOR CREW EXPOSURE.....	28
3.2.1.2.2-1 PARTIAL PRESSURE OXYGEN PHYSIOLOGICAL LIMITS FOR CREW EXPOSURE.....	29
3.2.1.2.3-1 PARTIAL PRESSURE CO ₂ PHYSIOLOGICAL LIMITS FOR CREW EXPOSURE.....	31
3.2.2.1.1-1 POTABLE WATER PHYSIOCHEMICAL LIMITS.....	39
3.2.2.1.2-1 POTABLE WATER MICROBIAL LIMITS.....	42
3.2.3.2.2-1 RELATIVE HUMIDITY TOLERANCE RANGES.....	49
3.2.5.1-1 FREQUENCY-WEIGHTED VIBRATION LIMITS BY EXPOSURE TIME DURING DYNAMIC PHASES OF FLIGHT.....	63
3.2.6.2.5-1 OCTAVE BAND SOUND PRESSURE LEVEL LIMITS.....	69
3.2.6.2.6-1 APPROVED INTERMITTENT NOISE SOURCES.....	70
3.2.6.2.6-2 INTERMITTENT NOISE A-WEIGHTED OVERALL SOUND PRESSURE LEVEL AND CORRESPONDING OPERATIONAL DURATION LIMITS (MEASURED AT 0.6 M).....	71
3.2.7.1.1-1 SYSTEM-SPECIFIC RADIATION DESIGN REQUIREMENTS.....	74
3.3.2.3-1 MINIMUM EDGE AND CORNER RADII FOR LOOSE EQUIPMENT.....	84
3.3.3.1-1 ELECTRICAL HAZARD POTENTIAL.....	85
3.3.3.1-2 LET-GO CURRENT.....	86
3.3.3.2-1 CHASSIS LEAKAGE CURRENT - NONPATIENT.....	86
3.3.3.3-1 CHASSIS LEAKAGE CURRENT - PATIENT.....	87
3.4.6.1.1-1 LIGHTING LEVEL BY TASK.....	98

Revision: E	Document No: CxP 70024
Release Date: 11/19/10	Page: 9 of 503
Title: Constellation Program Human-Systems Integration Requirements	

TABLE	PAGE
3.5.1.3.1-1 NUTRITION COMPOSITION BREAKDOWN TABLE.....	104
3.5.3.1-1 VOMITUS COLLECTION AND CONTAINMENT	108
3.5.3.2.5-1 DIARRHEA COLLECTION AND CONTAINMENT	110
3.5.5.3.5-1 MEDICAL CARE CAPABILITIES	120
3.10.4.1-1 PREBREATHE DURATIONS FOR CONTINGENCY EVA.....	170
3.10.4.1-2 PREBREATHE DURATIONS FOR NON-RECOVERABLE CABIN DEPRESS.....	172
3.10.5.1-1 MEASUREMENT OF PHYSIOLOGICAL PARAMETERS	176
3.10.5.2-1 DISPLAY OF PHYSIOLOGICAL PARAMETERS.....	177
3.10.5.3-1 ALERTING FOR OFF-NOMINAL PHYSIOLOGICAL PARAMETERS.....	178
3.10.5.4-1 TELEMETRY OF PHYSIOLOGICAL PARAMETERS	179
4.2.1.5.1-1 TRACE CHEMICAL CONTAMINANT DESIGN LOAD.....	189
4.3.4.1-1 HOT TOUCH TEMPERATURE CONSTANTS.....	231
4.3.4.1-2 INVERSE SQUARE ROOT OF THERMAL INERTIA FOR COMMON MATERIALS	231
4.3.4.2-1 COLD TOUCH TEMPERATURE CONSTANTS.....	235
4.3.4.2-2 INVERSE SQUARE ROOT OF THERMAL INERTIA FOR COMMON MATERIALS	235
B4-1 UNSUITED STRENGTH DATA	362
B4-2 UNPRESSURIZED SUITED STRENGTH DATA	369
B4-3 PRESSURIZED SUITED STRENGTH DATA	375
C1-1 CRITERIA FOR ASSIGNMENT OF TOXICOLOGICAL HAZARD LEVELS.....	383
C2-1 DIRECTION AND INTERTIAL RESULTANT OF BODY ACCELERATION	386
C3-1 MAXIMUM PERMISSIBLE EXPOSURE (MPE) TO RADIO FREQUENCY ELECTROMAGNETIC FIELDS (MODIFIED FROM IEEE C95.1-2005, LOWER TIER)	388
C3-2 BLUE-LIGHT AND RETINAL THERMAL HAZARD FUNCTIONS	389
C3-3 UV RADIATION EXPOSURE TLV AND SPECTRAL WEIGHTING FUNCTION.....	391
C3-4 PERMISSIBLE ULTRAVIOLET EXPOSURES (200 - 400 NM)	392
D-1 CORNER AND EDGE ROUNDING REQUIREMENTS	393

Revision: E	Document No: CxP 70024
Release Date: 11/19/10	Page: 10 of 503
Title: Constellation Program Human-Systems Integration Requirements	

TABLE		PAGE
E1-1	CORE TEMPERATURE RANGE LIMITS AND ASSOCIATED PERFORMANCE DECREMENTS	397
E1-2	CREW INDUCED METABOLIC LOADS FOR A STANDARD MISSION DAY WITH EXERCISE	399
E1-3	CREW INDUCED METABOLIC LOADS FOR A STANDARD MISSION DAY, NO EXERCISE	399
E1-4	CREWMEMBER METABOLIC RATES FOR SUITED OPERATIONS	401
H-1	TO BE DETERMINED ITEMS.....	405
I-1	TO BE RESOLVED ISSUES.....	406
J-1	ALLOCATION MATRIX FOR BLOCK 0 (ORION 1) DRM	408
J-2	ALLOCATION MATRIX FOR BLOCK 0 (ORION 2) DRM	421
J-3	ALLOCATION MATRIX FOR FFISS DRM	436
J-4	ALLOCATION MATRIX FOR EXO-LEO/LUNAR DRM.....	451
K1-1	INPUT-OUTPUT COMPATIBILITY	472
K2-1	EMERGENCY CODING TABLE	475
K3-1	ALERT ANNUNCIATION	476
L-1	FREQUENCY MULTIPLIER TABLE (FM).....	480
L-2	COUPLING TABLE.....	481
N2-1	MODEL COEFFICIENTS.....	489
N2-2	DYNAMIC RESPONSE LIMITS	491
N3-1	HEAD INJURY CRITERIA	493
N4-1	HEAD ACCELERATION LIMITS.....	494
N4-2	NECK PROTECTION CRITERIA.....	494
N4-3	TRANSIENT FORCE APPLICATION LIMITS	495
N4-4	RESTRAINED BODY MOVEMENT AND DEFLECTION <TBR-70024-001> ...	497
N4.1-1	DECONDITIONING FACTORS	500

FIGURE

3.2.4.1.2-1	+ G _x LINEAR SUSTAINED ACCELERATION LIMITS	54
3.2.4.1.2-2	- G _x LINEAR SUSTAINED ACCELERATION LIMITS	55
3.2.4.1.2-3	+G _z LINEAR SUSTAINED ACCELERATION LIMITS	55

Revision: E	Document No: CxP 70024
Release Date: 11/19/10	Page: 11 of 503
Title: Constellation Program Human-Systems Integration Requirements	

FIGURE	PAGE
3.2.4.1.2-4 - G_z LINEAR SUSTAINED ACCELERATION LIMITS	56
3.2.4.1.2-5 +/- G_y LINEAR SUSTAINED ACCELERATION LIMITS	56
3.2.4.4.3-1 ANGULAR RATE LIMITS	62
4.2.6.2.5-1 NUMBER OF MEASUREMENTS VS, STANDARD DEVIATION TO DETERMINE $A \pm 2$ DB 90% CONFIDENCE INTERVAL (FROM "ACOUSTICAL MEASUREMENTS AND NOISE CONTROL" BY C. M. HARRIS, P. 9.9, FIGURE 9.7)	214
4.3.4.1-1 ALLOWABLE HOT TOUCH TEMPERATURE DURATION	232
4.3.4.2-1 ALLOWABLE COLD TOUCH TEMPERATURE DURATION.....	236
C2-1 ACCELERATION ENVIRONMENT COORDINATE SYSTEM.....	385
C3-1 RADIO FREQUENCY ELECTROMAGNETIC FIELD EXPOSURE LIMITS (ILLUSTRATED TO SHOW WHOLE BODY RESONANCE EFFECTS AROUND 100 MHZ) (MODIFIED FROM IEEE C95.1-2005)	387
E1-1 ENVIRONMENTAL COMFORT ZONE	395
E1-2 HEAT STORAGE.....	396
E1-3 TIME ALLOWED IN SUIT AS LIMITED BY ENVIRONMENTAL CONDITIONS AND ACTIVITY LEVEL WITHOUT INTERNAL GARMENT COOLING, WISSLER ACES MODEL	402
L-1 HORIZONTAL MEASUREMENT FIGURE.....	478
L-2 MEASURE OF ASYMETRY ANGLE A	479
L-3 LIFTING ANALYSIS WORKSHEET	482
M-1 INBOARD WINDOW VIEW NO OBSTRUCTION ZONE	484
M-2 OUTBOARD WINDOW VIEW NO OBSTRUCTION ZONE	485
N2-1 CRITICAL POINT DEFINITION OF A SEATED OCCUPANT	490

Revision: E	Document No: CxP 70024
Release Date: 11/19/10	Page: 12 of 503
Title: Constellation Program Human-Systems Integration Requirements	

1 INTRODUCTION

The Human-Systems Integration Requirements (HSIR) in this document drive the design of space vehicles, their systems, and equipment with which humans interface in the Constellation Program (CxP). These requirements ensure that the design of Constellation (Cx) systems is centered on the needs, capabilities, and limitations of the human.

These requirements embody the collective experience of the National Aeronautics and Space Administration (NASA) in the operation of human spacecraft from Project Mercury to the International Space Station (ISS), and were derived from NASA-STD-3000, Volume I; Man-Systems Integration Standards (MSIS), Revision B, 1995; JSC 26882, Space Flight Health Requirements; MIL-STD-1472F, Department of Defense Design Criteria Standard, Human Engineering; FAA-HF-STD-001, Federal Aviation Administration Human Factors Design Standard; and other sources.

1.1 PURPOSE

The HSIR provides requirements to ensure proper integration of human-to-system interfaces. These requirements apply to all mission phases, including pre-launch, ascent, Earth orbit, trans-lunar flight, lunar orbit, lunar landing, lunar ascent, Earth return, Earth entry, Earth landing, post-landing, and recovery.

The Constellation Program must meet NASA's Agency-level human rating requirements, which are intended to ensure crew survival without permanent disability. The HSIR provides a key mechanism for achieving human rating of Constellation systems.

1.2 SCOPE AND PRECEDENCE

The requirements in this document are applicable to the Constellation Systems, including but not limited to Orion, Ares I, Ares V, Altair, Mission Systems (MS), Ground Operations (GO), Extravehicular Activity (EVA), and Flight Crew Equipment (FCE); and are allocated to each System per Appendix J, Allocation Matrix. A future version of this document will address other Constellation Systems. The HSIR contains those requirements that specifically address the needs and limitations of the human, regardless of the vehicle in which they are implemented. Vehicle-specific and system-specific requirements that are the implementation of human functional requirements can be found in System Requirements Documents (SRDs).

The requirements in this document address the needs of the flight crew during all phases of flight. These requirements also address the needs of ground personnel during pre-flight preparation, maintenance, and post-flight activities on the flight vehicles where there is a common interface with the flight crew.

While this document contains requirements for vehicle interfaces to be used by suited crewmembers inside the vehicle, it does not cover those vehicle interfaces to be used by suited crewmembers during EVA operations outside the vehicle. Those

Revision: E	Document No: CxP 70024
Release Date: 11/19/10	Page: 13 of 503
Title: Constellation Program Human-Systems Integration Requirements	

requirements may be found in CxP 70130, Constellation Program Extravehicular Activity Design and Construction Specification, and the EVA to Systems Interface Requirements Documents (IRDs).

1.3 IMPLEMENTATION

The convention used in this document to distinguish between requirements and goals is as follows: "shall" is used to indicate requirements that must be implemented and verified, and "should" is used to indicate goals that must be addressed by the design but do not need to be verified. Objective stretch requirements are denoted with [HSxxxx-Objective]. The Objective requirements represent future goals that, in time, may replace the existing threshold requirements. Verification requirements are not required for the stretch Objective requirements in this document.

The purpose of the Rationale statement is to indicate why the requirement is needed, the basis for its inclusion in a requirements document, and to provide context and examples to stakeholders. It is important to note that the rationales are not binding and only provide supporting information.

1.4 CHANGE AUTHORITY/RESPONSIBILITY

Proposed changes to this document shall be submitted by a Constellation Program Change Request (CR) to the Constellation Systems Engineering Control Board (CxSECB) for consideration and disposition.

All such requests will adhere to the Constellation Program Configuration Management Change Process.

The appropriate NASA Office of Primary Responsibility (OPR) identified for this document is Constellation Systems Engineering and Integration (SE&I).

2 DOCUMENTS

2.1 APPLICABLE DOCUMENTS

Document Number	Document Revision	Document Title
ANSI S12.65-2006		American National Standard for Rating Noise with Respect to Speech Interference
ANSI S3.2-2009		American National Standard Method for Measuring the Intelligibility of Speech Over Communication Systems
ANSI Z136.1 (2007)		American National Standard for Safe Use of Lasers

Revision: E	Document No: CxP 70024
Release Date: 11/19/10	Page: 14 of 503
Title: Constellation Program Human-Systems Integration Requirements	

Document Number	Document Revision	Document Title
CxP 70023	Rev A	Constellation Program Design Specification for Natural Environments
CxP 70035		Constellation Program Portable Equipment, Payloads, and Cargo (PEPC) Interface Requirements Document
CxP 70080	Rev A CPN-001	Constellation Program Electromagnetic Environmental Effects (E3) Requirements Document
CxP 70135		Constellation Program Structural Design and Verification Requirements
CxP 70136-ANX01	BASELINE CPN-001	Constellation Program Loads Data Book Annex 1: System-To-System Interface Loads
CxP 70137		Constellation Program Loads Control Plan
CxP 70160-ANX03		Constellation Program Data Architecture Implementation Plan, Annex 3: Naming and Identification Rules
CxP 70172-01		Constellation Program Data Architecture Specification, Volume 1: Naming and Identification Rules
CxP 72407		Orion Crew Exploration Vehicle Window Optical Properties Requirements
FAA-HF-STD-001		Federal Aviation Administration Human Factors Design Standard
FED-STD-595		Colors Used in Government Procurement
IEEE C95.1-2005		IEEE Standard for Safety Levels with Respect to Human Exposure to Radio Frequency Electromagnetic Fields, 3 kHz to 300 GHz
ISBN 0875530478		Standard Methods for Examination of Water & Wastewater
ISO 2631-1:1997		Mechanical Vibration and Shock - Evaluation of Human Exposure to Whole Body Vibration

Revision: E	Document No: CxP 70024
Release Date: 11/19/10	Page: 15 of 503
Title: Constellation Program Human-Systems Integration Requirements	

Document Number	Document Revision	Document Title
ISO 3382		Measurement of the Reverberation Time of Rooms with Reference to Other Acoustical Parameters
ISO 6954:2000		Mechanical vibration -- Guidelines for the measurement, reporting and evaluation of vibration with regard to habitability on passenger and merchant ships
JSC 20584		Spacecraft Maximum Allowable Concentrations for Airborne Contaminants
JSC 63307		Requirements for Optical Properties for Windows Used in Crewed Spacecraft
NASA TND-5153		The use of pilot rating in the evaluation of aircraft handling qualities
NASA-STD-3000		Man-Systems Integration Standards, Volume 1
NASA-STD-6001		Flammability, Odor, Off-Gassing, and Compatibility Requirements and Test Procedures for Materials in Environments that Support Combustion
NATICK/TR-89/044		1988 Anthropometric Survey of U.S. Army Personnel: Methods and Summary Statistics
NCRP Report Number 132		Radiation Protection Ordinance for Activities in Low-Earth Orbit
No Number		41-Node man model for calculating stored body heat
No Number		Wissler model for calculating stored body heat
No Number		Webster's New World Dictionary of American English
No Number		"Usability Engineering" (1993) by Jakob Nielsen

Revision: E	Document No: CxP 70024
Release Date: 11/19/10	Page: 16 of 503
Title: Constellation Program Human-Systems Integration Requirements	

2.2 REFERENCE DOCUMENTS

Document Number	Document Revision	Document Title
2005-01-2872		International Conference on Environment Systems (ICES) Paper "An Environmental Sensor Technology Selection Process for Exploration"
AATD Development Program Phase 1 Reports		AATD System Technical Characteristics, Design Concepts, and Trauma Assessment Criteria
ACGIH		American Conference of Governmental Industrial Hygienists (ACGIH) Standards, "Threshold Limit Values and Biological Exposure Indices"
ACGIH TLVs® and BEIs®, 2007		American Conference of Governmental Industrial Hygienists (ACGIH) standard for "Threshold Limit Values (TLVs®) and Biological Exposure Indices (BEIs®)," 2007, sections Infrasound and Low-Frequency Sound, Light and Near-Infrared Radiation, and Ultraviolet Radiation
AGARD AR-330		Advisory Group for Aerospace Research and Development consensus advisory report AR-330: Anthropometric Dummies for Crash and Escape Testing.
AGARD CP-597		Advisory Group for Aerospace Research and Development consensus advisory report AR-597: Impact Head Injury Responses, Mechanisms, Tolerances, Treatment and Countermeasures.
AGARD-CP-472		Development of Acceleration Exposure Limits for Advanced Escape Systems
ATR-2000 (2112)-1		International Space Station Destiny Module Science Window Optical Properties and Wavefront Verification Test Results
ATR-2003 (7828)-1		International Space Station Cupola Scratch Pane Window Optical Test Results
CAIT IDAQ4		Denitrogenation and Decompression Sickness (DCS)

Revision: E	Document No: CxP 70024
Release Date: 11/19/10	Page: 17 of 503
Title: Constellation Program Human-Systems Integration Requirements	

Document Number	Document Revision	Document Title
SIG-05-1034		Task Description Sheet (TDS)
CFR49 Part 571 and 572		Federal Motor Vehicle Safety Standards, Title 49 Code of Federal Regulations, Part 571 and 572
CxP 70000	Rev C	Constellation Architecture Requirements Document (CARD)
CxP 70000	Rev C CPN-001	Constellation Architecture Requirements Document (CARD)
CxP 70007		Constellation Design Reference Missions and Operational Concepts, Annex 2: Flight Operations Scenarios
CxP 72000	Rev B	Constellation Program System Requirements for the Orion System
DRD T-045		Space Radiation Analysis and Certification Report
EC-09-154		Bue, Grant; Tolerable limit for hand skin temperatures in glove tests, EC-09-154, October 30, 2009
FAA-HF-STD-001		Federal Aviation Administration Human Factors Design Standard
IEEE C95.1-2005		IEEE Standard for Safety Levels with Respect to Human Exposure to Radio Frequency Electromagnetic Fields, 3 kHz to 300 GHz
ISBN 0387988203		Accidental Injury: Biomechanics and Prevention
ISBN 0879951508		The IESNA lighting handbook
ISBN 1560910070		Automotive Safety: Anatomy, injury, testing, and regulation
ISO 13732-3		Ergonomics of the thermal environment – Methods for the assessment of human responses to contact with surfaces, Part 3: Cold Surfaces

Revision: E	Document No: CxP 70024
Release Date: 11/19/10	Page: 18 of 503
Title: Constellation Program Human-Systems Integration Requirements	

Document Number	Document Revision	Document Title
ISO 2631-1:1997		Mechanical Vibration and Shock - Evaluation of Human Exposure to Whole Body Vibration
ISO 6954:2000		Mechanical vibration -- Guidelines for the measurement, reporting and evaluation of vibration with regard to habitability on passenger and merchant ships
ISO 7731		Ergonomics - Danger signals for public work areas Auditory danger signals
JSC 20584		Spacecraft Maximum Allowable Concentrations for Airborne Contaminants
JSC 39116		"EMU Phase VI Glove Thermal Vacuum Test and Analysis Final Report", Doc. #CTSD-SS-1621
JSC 63414		Spacecraft Water Exposure Guidelines (SWEG)
JSC 63555		Nutrition requirements, Standards, and Operating Bands for Exploration Missions
JSSG-2010-7		Department of Defense Joint Service Specification Guide - Crew Systems Crash Protection Handbook
MIL-S-58095A		Seat System Crash-Resistance, Non-Ejection, Aircrew, General Specification for, 31 January 1986
MIL-S-9479E		Seat System, Upward Ejection, Aircraft, General Specification for
MIL-STD-1472		Department of Defense Design Criteria Standard-Human Engineering
MIL-STD-1474D		Department of Defense Design Criteria Standard-Noise Limits
NASA-MEMO-5-19-59E		Human Tolerance to Rapidly Applied Accelerations

Revision: E	Document No: CxP 70024
Release Date: 11/19/10	Page: 19 of 503
Title: Constellation Program Human-Systems Integration Requirements	

Document Number	Document Revision	Document Title
NASA-STD-3001		Space Flight Human Systems Standard, Volume 1: Crew Health
NASA-TM-2008-215198		The Use of a Vehicle Acceleration Exposure Limit Model and a Finite Element Crash Test Dummy Model to Evaluate the Risk of Injuries During Orion Crew Module Landings
NASA-TN-D-6539		Predicting the Dynamic Response of the Apollo Command Module to Earth Impact
NASA-TN-D-7440		Apollo Experience Report – Command Module Crew Couch/Restraint and Load-Attenuation Systems
NASA/TM 108497		Trace Chemical Contaminant Generation Rates for Spacecraft Contamination Control System Design
NASA/ TP-1998-207978		Elements of Spacecraft Cabin Air Quality Design
NIOSH Publication No. 94-110		The Applications Manual For the Revised NIOSH Lifting Equation
No Number		Deliberations of the Exploration Atmospheres Working Group (EAWG)
No Number		Russian "State Standard" (referred to as GOST)
No Number		Space Physiology and Medicine (1994) Thermo-degradation of materials
No Number		Environmental Protection Agency (EPA) Maximum Contamination Level (MCL)
No Number		M.J. Griffin, "Handbook of Human Vibration"
No Number		Man's Short-Time Tolerance to Sinusoidal Vibration
No Number		Beranek and Ver, Noise and Vibration Control Engineering, 1992

Revision: E	Document No: CxP 70024
Release Date: 11/19/10	Page: 20 of 503
Title: Constellation Program Human-Systems Integration Requirements	

Document Number	Document Revision	Document Title
No Number		C.M. Harris, "Handbook of Acoustical Measurements and Noise Control, 3rd Ed."
No Number		Greene, L.C., Alden, J.C. and Hardy, J.D.; Adaptation to Pain. Fed. Proc. 17: 60, 1958.
No Number		Hatton, A.P. and Halfdanarson. Role of Contact Resistance in Skin Burns. J. of Biomed Eng. Volume 4, April 1982, pp. 97-102
No Number		Havenith G, van de Linde EJG, Heus R. (1992) Pain, thermal sensation and cooling rates of hands while touching cold materials. Eur J Appl Physiol; 65: 43-51
No Number		Lloyd-Smith, D.L. and Mendelssohn, K. Tolerance Limits to Radiant Heat. Brit. Med. J., p. 975, 1948.
No Number		Moritz, A.R. and Henriques, F.C. Studies in Thermal Injury II. The Relative Importance of Time and Air Surface Temperatures in the Causation of Cutaneous Burns. American Journal of Pathology, 23:695-720 (1947).
No Number		Provins KA, Morton R. (1960) Tactile Discrimination and Skin Temperature. J Appl Physiol;15: 155-60.
No Number		Stoll, A.M., Chianta, M.A. and Piergallini, J.R. Thermal Conduction Effects in Human Skin. Aviation, Space and Environmental Medicine. 50(8):778-787, 1979.
No Number		Geng, Q., Holmer, I., Hartog, D.E.A, Havenith, G., Jay, O., Malchaire, J., Piette, A., Rintamaki, H., Rissanen, S.; Temperature Limit Values for Touching Cold Surfaces with the Fingertip. Ann. Occup. Hyg., pp.1-12. (2006).
No Number		Hardy, J.D, Wolff, H.G., Goodel, Williams, H. and Wilkins; Pain Sensations and Reactions, Baltimore, 1952., pg 142.

Revision: E	Document No: CxP 70024
Release Date: 11/19/10	Page: 21 of 503
Title: Constellation Program Human-Systems Integration Requirements	

Document Number	Document Revision	Document Title
No Number		Scientific and Technical Information Center Vehicle Integration and Test Office Window Testing report
No Number		IENSA Lighting Handbook
No Number		Overhead and forward reach capability during exposure to +1 to +6 G _x loads.
No Number		Schafer & Bagian, Aviation, Space, and Environmental Medicine, 64: 979, 1993
No Number		U.S. Navy Treatment Table 6
SAE 1988-12-0013		SAE Automotive Safety: Testing & Evaluation of Hybrid III Load Sensing Face
SAE 983161		SAE Automotive Safety: Biomechanical Analysis of Indy Race Car Crashes
SAE J885		SAE Automotive Safety: Human Tolerances to Impact Conditions as Related to Motor Vehicle Design
SAE PT-43		SAE Automotive Safety: Biomechanics of Impact Injury and Injury Tolerances of the Head-Neck Complex
SAE PT-44		SAE Automotive Safety: HYBRID III: The First Human-like Crash Test Dummy
SAE PT-47		SAE Automotive Safety: Biomechanics of Impact Injuries and Injury Tolerances of the Abdomen, Lumbar Spine and Pelvis Complex
SAE SP-731		SAE Automotive Safety: Injury Biomechanics
SID 64-1344C		Apollo launch data for the Command Module couch
SSP 50260	Revision C	ISS Medical Operations Requirements Document (MORD)
SSP 50653-1		Basic Provisions on Crew Actions in the Event of a Toxic Release on the ISS

Revision: E	Document No: CxP 70024
Release Date: 11/19/10	Page: 22 of 503
Title: Constellation Program Human-Systems Integration Requirements	

Document Number	Document Revision	Document Title
SSP 57000		Pressurized Payload Interface Requirements Document
USAAVSCOM TR-89-D-22A		Aircraft crash survival design guide: Volume I - Design criteria and checklists

3 HUMAN-SYSTEMS REQUIREMENTS

3.1 ANTHROPOMETRY, BIOMECHANICS, AND STRENGTH

This section contains requirements based on the physical size, shape, reach, posture, and strength of potential crewmembers. These data are to be used to design vehicles and the hardware and equipment used therein, to accommodate the physical size, shape, reach, range of motion, and strength of crewmembers.

Crewmembers can conduct operations unsuited, pressurized suited, or unpressurized suited. An analysis of operations must be performed to identify all tasks and task conditions. (This list of tasks is referred to in this section as "planned tasks" and includes both nominal and off-nominal tasks.) Some tasks (e.g., personal hygiene) will only be conducted by an unsuited crewmember. Other operations (e.g., pre-launch) may never be done in anything more than an unpressurized suit. The design must accommodate worst-case conditions. For example, if it is feasible that a pressurized suited crewmember will be in a location and using equipment, then the design of equipment and location must accommodate a pressurized suited crewmember.

3.1.1 Anthropometry

3.1.1.1 Anthropometric Dimensions for Unsuited Crewmembers

[HS2001] The system shall provide fit, access, reach, view, and operation of human-systems interfaces in crew functional areas for unsuited crewmembers as defined in Appendix B, tables Anthropometric Dimensional Data for American Female and Male, Vehicle Design Critical Anthropometry Dimensions, and Suit Design Critical Anthropometry Dimensions.

Rationale: The full size range of an unsuited crewmember must be able to fit, reach, view, and operate all required human-systems interfaces in the crew functional areas that do not require protective suits. Because the current and future crewmembers' body dimensions could have a wide range, it is necessary to use the full range provided in these tables to ensure crew accommodation.

Revision: E	Document No: CxP 70024
Release Date: 11/19/10	Page: 23 of 503
Title: Constellation Program Human-Systems Integration Requirements	

3.1.1.2 Anthropometric Dimensions for Suited Crewmembers

[HS2002] The system shall provide fit, access, reach, view, and operation of human-systems interfaces in crew functional areas for pressurized suited crewmembers as defined in Appendix B, table Vehicle Design Critical Anthropometry Dimensions and table Suit Design Critical Anthropometry Dimensions.

Rationale: The full size range of suited crewmembers must be able to fit, reach, view, and operate required human-systems interfaces involved in planned tasks in the crew functional areas that require protective pressurized suits.

3.1.2 Range of Motion

3.1.2.1 Range of Motion of an Unsuited Crewmember

[HS2003] Aspects of the system with which unsuited crewmembers physically interact during planned tasks shall be within the ranges of motion provided in Appendix B, table Unsuited Joint Mobility.

Rationale: All vehicle seats and restraints need to be adjustable to accommodate the crewmembers' ranges of motion. Crew interfaces and controls with which the unsuited crew will interact must be located such that they can be reached from the restrained positions within the range of motion of the crewmember as defined in Appendix B, table Unsuited Joint Mobility. The range of motion numbers present in these tables show the level of mobility that is needed to perform a variety of relevant functional tasks. These numbers do not necessarily indicate maximum level of mobility possible in a given configuration.

3.1.2.2 Range of Motion of a Suited Crewmember

[HS2004] Aspects of the system with which suited crewmembers physically interact during planned tasks shall be within the ranges of motion provided in Appendix B, table Unpressurized Suited Joint Mobility and table Pressurized Suited Joint Mobility for Nominal Pressure Microgravity Operations.

Rationale: Suited crewmembers should not have to reposition themselves each time they manually operate and view the vehicle's user interfaces. All vehicle seats and restraints need to be adjustable to accommodate the crewmember's ranges of motion. Crew interfaces and controls with which the suited crew will interact must be located such that they can be reached from the restrained positions within the range of motion of the crewmember. Suits can limit the crew range of motion below the range of motion of the unsuited crew as specified in Appendix B, table Unpressurized Suited Joint Mobility. Suit pressurization can further reduce the range of motion of the crewmember as specified in Appendix B, table Pressurized Suited Joint Mobility for Nominal Pressure Microgravity Operations. The range of motion numbers present in these tables show the level of mobility that was needed to perform a variety of relevant

Revision: E	Document No: CxP 70024
Release Date: 11/19/10	Page: 24 of 503
Title: Constellation Program Human-Systems Integration Requirements	

functional tasks. These numbers do not necessarily indicate maximum level of mobility possible in a given configuration.

3.1.3 Mass Properties

3.1.3.1 Total Crew Control Mass

[HS2010] The system shall accommodate a total crew control mass, as shown in HS2010, table Total Crew Control Mass, to mission destination through return.

TABLE 3.1.3.1-1 - TOTAL CREW CONTROL MASS

Vehicle	Four Crew (kg [lb])
Orion	327 (720)
Altair	327 (720)

Rationale: Total crew mass is based on a statistically derived value established to ensure, with high probability, that vehicle performance and mass allocations will be sufficient to accommodate crews selected from the astronaut corps without consideration of individual crew mass. Individual crew mass is already a criteria of individual crew selection to the corps. Insufficient total crew mass capabilities creates a burden for mission crew selection of larger crewmembers, requiring other crewmembers to be smaller and requiring backup crewmembers for smaller crewmembers to be similarly small. Total crew mass numbers are derived using a weight-truncated database based on the Natick U.S. Army Anthropometric Survey (ANSUR) data trended to show growth through 2015. The specification of crew mass uses this weight-truncated database for crewmembers using a Monte Carlo simulation to identify the 80th percentile total crew mass given a distribution of 18.5% of females in the population for four crew. For simplicity, this requirement assumes an average individual mass of 82 kg (180 lb). Individual crew mass is the Max single crew mass per Appendix B, table Whole Body Mass of Crewmember. Crew masses specified are for unclothed or lightly clothed crewmembers and should be considered in addition to clothing and suit masses.

3.1.3.2 Mass Properties of an Unsuiting Crewmember

[HS2005] Aspects of the system with which an unsuited crewmember physically interacts during acceleration should accommodate crewmember mass properties as defined in all tables in Appendix B, Section B3.0 Mass Properties.

Rationale: Body support systems (seats, brackets, restraints, etc.) must accommodate forces exerted by an unsuited crewmember under all anticipated accelerations.

Revision: E	Document No: CxP 70024
Release Date: 11/19/10	Page: 25 of 503
Title: Constellation Program Human-Systems Integration Requirements	

3.1.3.3 Mass Properties of a Suited Crewmember

[HS2006] Aspects of the system with which a suited crewmember may physically interact during planned tasks shall accommodate the mass of the suited crewmember provided in Appendix B, table Whole-Body Mass of Crewmember.

Rationale: All vehicle systems with human-systems interfaces need to be designed such that they will not be damaged after being subjected to the forces that a large suited crewmember can impart on that interface. Also, body support systems (seats, brackets, restraints, etc.) must accommodate forces exerted by a suited crewmember under all anticipated acceleration and gravity environments.

3.1.4 Strength

3.1.4.1 Structural Integrity of Hardware for an Unsited Crewmember

[HS2007] System components and equipment that are intended to be operated by unsited crew shall withstand the forces in the "Maximum Crew Operational Loads" column of Appendix B, table Unsited Strength Data without sustaining damage.

Rationale: Vehicle components and equipment must be designed to withstand large forces exerted by a strong crewmember during nominal operation without breaking. These limits are defined by the Maximum Crew Operational Loads.

3.1.4.2 Structural Integrity of Hardware for a Suited Crewmember

[HS2007B] System components and equipment that will be operated by the suited crew should withstand the forces in the "Maximum Crew Operational Loads" column of Appendix B, table Unpressurized Suited Strength Data and table Pressurized Suited Strength Data.

Rationale: Vehicle components and equipment must be designed to withstand large forces exerted by a strong crewmember during nominal operation without breaking. These limits are defined by the Maximum Crew Operational Loads. Applicable pressurization cases can be defined by analysis.

3.1.4.3 Minimum Crew Operational Loads for an Unsited Crewmember

[HS2008] System components and equipment that are intended to be operated by unsited crew shall require forces no greater than the Minimum Crew Operational Loads as defined in Appendix B, table Unsited Strength Data.

Rationale: A weaker crewmember should be able to perform any requested tasks. These limits are defined by the Minimum Crew Operational Loads. Criticality 1 load limits are for activities related to crew safety; Criticality 2 load limits are for activities related to Loss of Mission (LOM).

Revision: E	Document No: CxP 70024
Release Date: 11/19/10	Page: 26 of 503
Title: Constellation Program Human-Systems Integration Requirements	

3.1.4.4 Minimum Crew Operational Loads for a Suited Crewmember

[HS2008B] System components and equipment that are intended to be operated by suited crew should require forces no greater than the Minimum Crew Operational Loads as defined in the appropriate data in Appendix B, table Unpressurized Suited Strength Data and table Pressurized Suited Strength Data.

Rationale: A weaker crewmember should be able to perform any requested tasks. These limits are defined by the Minimum Crew Operational Loads. Criticality 1 load limits are for activities related to crew safety; Criticality 2 load limits are for activities related to Loss of Mission. Unpressurized suits can limit strength capability as specified in table Unpressurized Suited Strength Data. Suit pressurization can further reduce strength capability as noted in table Pressurized Suited Strength Data. The strength data for suited crew are estimates only and are dependent on the final suit configuration. Applicable pressurization cases can be defined by analysis.

3.1.4.5 Equipment Damage Hazard

[HS2009] The system shall design hardware that is exposed to crew induced inadvertent contact loads per CxP 70135, Constellation Program Structural Design and Verification Requirements, Section 3.0, and the loads specified in CxP 70136-ANX01, Constellation Program Loads Data Book, Annex 1: System-to-System Interface Loads, Section 3.0.

Rationale: System components and hardware with which the crew interacts during nominal operations on-orbit must be able to withstand incidental contact by crewmembers without creating a hazard.

3.2 NATURAL AND INDUCED ENVIRONMENTS

3.2.1 Atmosphere

This section contains requirements for the design of systems to maintain atmospheric composition and pressure limits, to monitor and control the atmosphere, and to limit contaminants and toxins.

3.2.1.1 Atmospheric Quality for Nominal Vehicle Operations

3.2.1.1.1 Total Pressure for Nominal Vehicle Operations

[HS3004] The system shall maintain internal pressure to operate within 51.7 kPa (7.50 psia) (388 mmHg) and 103 kPa (15.0 psia) (773 mmHg).

Rationale: The nominal limits for total pressure are based on deliberations of the Exploration Atmospheres Working Group (EAWG), except for maximum total pressure where the value is chosen to be high enough not to limit normal operations of approximately 101 kPa (14.7 psia) and low enough to prevent excessive nitrogen saturation before EVA operations. The lower pressure limit

Revision: E	Document No: CxP 70024
Release Date: 11/19/10	Page: 27 of 503
Title: Constellation Program Human-Systems Integration Requirements	

will enhance operational capability for EVA by reducing prebreathe time without impacting Decompression Sickness (DCS) risk and potentially reduce the atmospheric consumable burden. Operating within a narrower total pressure range is acceptable as long as it falls within the 51.7 kPa (7.50 psia) to 103 kPa (15.0 psia) nominal range of operations. For Orion flights independent of the ISS, structural mass savings are possible with lower loads due to reduced cabin pressure. Transient operations at pressures outside this nominal range are tolerated per HS3005, including suited operations which typically fall outside the nominal range.

3.2.1.1.2 O₂ Partial Pressure for Nominal Vehicle Operations

[HS3004B] The system shall maintain the partial pressure of oxygen in the internal atmosphere to operate within 18.5 kPa (2.69 psia) (139 mmHg) and 23.7 kPa (3.44 psia) (178 mmHg).

Rationale: This requirement ensures that the crewmembers will be comfortable to perform on-orbit tasks requiring enhanced mental alertness and concentration, and will be able to sustain physically demanding cardiopulmonary and muscular loading, such as during countermeasure exercises or EVA, without any performance decrements or toxicity that could be induced by insufficient or excess oxygen partial pressure. The United States (US) Occupational Safety and Health Administration (OSHA) specifies that the minimum oxygen level for entry into an enclosed space is 19.5% at sea level pressure (ppO₂ 148 mmHg, equivalent 2,000 ft). The range of ppO₂ available to be breathed by >80% of the world's population terrestrially is 145-178 mmHg, which is equivalent to sea level to 3,000 feet altitude. This is the ppO₂ recommended for extended nominal spaceflight operations by several space biomedical sources. Joint US and Russian biomedical sourcebooks recommend keeping spacecraft ppO₂ above 128 mmHg (below the equivalent flight altitude of 2,000 m or approximately 6,000 ft level) in order to allow the performance of physical work in the face of cardiovascular and vestibular effects due to weightlessness. Certain mission profiles will not allow ppO₂ to remain in the nominal physiological range during all mission phases. Excursions from the nominal range of 18.5 kPa (139 mmHg) to 23.7 kPa (178 mmHg) are allowed provided they meet the time limitations presented in HS3005B. CxP 70000 Constellation Architecture Requirements Document (CARD) ppO₂ requirement (CA3133-PO) (17 kPa [2.5 psia] to 21 kPa [3.1 psia]) accounts for post-acclimatization indefinite exposure to lower oxygen ppO₂ at the lower limit, and fire hazard controls at the upper limit.

3.2.1.1.3 CO₂ Partial Pressure for Nominal Vehicle Operations

[HS3004C] The system shall maintain the partial pressure of carbon dioxide in the internal atmosphere to less than 0.67 kPa (0.10 psia) (5.0 mmHg) average over any 1-hour time frame.

Revision: E	Document No: CxP 70024
Release Date: 11/19/10	Page: 28 of 503
Title: Constellation Program Human-Systems Integration Requirements	

Rationale: There is no minimum CO₂ atmospheric requirement for human existence, as humans produce carbon dioxide with metabolic respiration. The NASA Spacecraft Maximum Allowable Concentration (SMAC) for 30- and 180-day Time Weighted Average (TWA) is 5.3 mmHg, from JSC 20584, Spacecraft Maximum Allowable Concentrations for Airborne Contaminants. No performance decrements during standard operations result with inspired CO₂ levels < 0.67 kPa (0.10 psia) (5.0 mmHg) as an average for a 1-hour time frame.

3.2.1.1.4 N₂ Partial Pressure for Nominal Vehicle Operations

[HS3004D] The system shall maintain the partial pressure of nitrogen in the internal atmosphere between 10.3 kPa (1.50 psia) (77.5 mmHg) and 82.8 kPa (12.0 psia) (621 mmHg) for missions greater than 10 days.

Rationale: No diluent gas is required for short duration space missions or time limited EVAs, as long as the total atmosphere meets fire safety specifications for the system and the materials within it. Diluent gas is required in nominal long duration breathable atmospheres to prevent pulmonary alveolar atelectasis in addition to reducing the ignition/flammability threshold. The choice of diluent gas is dependent on many factors, but the human is well adapted to the presence of nitrogen because it is inert. However, nitrogen does possess the risk of evolution from the tissue and DCS when the individual is exposed to hypobaric conditions. Maximum: For nominal operations, the max limit for nitrogen is set to reduce excess nitrogen saturation in the event that a contingency EVA will be performed without a prolonged oxygen prebreathe. Due to its inert nature, nitrogen does not cause significant measurable physiological effects in humans until it reaches levels equivalent to several atmospheres of depth, and therefore the nitrogen narcosis limit is 395 kPa (57.3 psia) (2,960 mmHg).

3.2.1.2 Atmospheric Quality Limits for Crew Exposure

3.2.1.2.1 Total Pressure Tolerance Ranges for Crew Exposure

[HS3005] The system shall maintain the pressure that the crew is exposed to within the internal atmosphere during off-nominal operations within the limits shown in HS3005, table Physiological Total Pressure Limits for Crew Exposure.

TABLE 3.2.1.2.1-1 - PHYSIOLOGICAL TOTAL PRESSURE LIMITS FOR CREW EXPOSURE

Total Pressure (kPa)	Total Pressure (psia)	Time
Pressure ≤ 20.7	Pressure ≤ 3.00	0
20.7 < Pressure ≤ 29.6	3.00 < Pressure ≤ 4.30	12 hours
29.6 < Pressure ≤ 51.7	4.30 < Pressure ≤ 7.50	14 days
51.7 < Pressure ≤ 103	7.50 < Pressure ≤ 15.0	Indefinite
103 < Pressure ≤ 117	15.0 < Pressure ≤ 17.0	12 hours
Pressure > 117	Pressure > 17.0	Contingency only

NOTES:

1. Kilopascal (kPa) is the International System of Units (SI). Other units are for reference only.
2. Nominal pressure ranges are included for completeness and denoted by italic font. HS3004 is the requirement for nominal pressure.

Rationale: The nominal and contingency limits for total pressure are based on deliberations of the Exploration Atmospheres Working Group (EAWG) for suited operations. Total pressure of 20.7 kPa (3.00 psia) (155 mmHg), assuming that the crew is at rest, on 100% O₂ and a mask seal without leaks is the lowest possible contingency or EVA nominal operations ppO₂ to prevent both hypoxia and early manifestations of ebullism, as well as excess DCS risk. The maximum limit (contingency only) is based on operational capability (assuming the use of nitrogen as a diluent gas) and limits excess nitrogen saturation that would affect DCS risk and that would be required to operate at higher pressures without exceeding fire limits. This limit is far below the current maximal pressure endurance for humans, based on diving exposure, which is approximately 3,300 kPa (479 psia) (24,800 mmHg) using Self-Contained Underwater Breathing Apparatus (SCUBA) at 318.25 meters (1,044.1 ft) of sea water, June 13, 2005 for less than 1 hour. For suited operations (e.g., EVA or contingency Intravehicular Activity [IVA] operations), the vehicle must be able to go to vacuum, but the pressure the crew is exposed to should not fall outside the pressure ranges stated in HS3005, table Physiological Total Pressure Limits for Crew Exposure. If there should be a DCS event requiring treatment, then an off-nominal crew exposure pressure >117 kPa (17.0 psia) (879 mmHg) up to 157 kPa (22.7 psia) (1,170 mmHg) or higher may be required to treat the DCS episode for a transient exposure period and likely will be at enriched oxygen concentration. Discriminate set points for suit pressure within suit operating pressure limits are defined in HS11000.

3.2.1.2.2 O₂ Partial Pressure Tolerance Ranges for Crew Exposure

[HS3005B] The system shall maintain oxygen partial pressure to operate within the limits defined in HS3005B, table Partial Pressure Oxygen Physiological Limits for Crew Exposure.

TABLE 3.2.1.2.2-1 - PARTIAL PRESSURE OXYGEN PHYSIOLOGICAL LIMITS FOR CREW EXPOSURE

ppO ₂ (kPa)	ppO ₂ (mmHg)	ppO ₂ (psia)	Maximum Time Allowed
ppO ₂ > 82.8	ppO ₂ > 621	ppO ₂ > 12.0	≤ 6 hours
70.3 < ppO ₂ ≤ 82.8	527 < ppO ₂ ≤ 621	10.2 < ppO ₂ ≤ 12.0	≤ 18 hours
62.1 < ppO ₂ ≤ 70.3	466 < ppO ₂ ≤ 527	9.01 < ppO ₂ ≤ 10.2	≤ 24 hours
33.5 < ppO ₂ ≤ 62.1	251 < ppO ₂ ≤ 466	4.85 < ppO ₂ ≤ 9.01	≤ 48 hours
23.7 < ppO ₂ ≤ 33.5	178 < ppO ₂ ≤ 251	3.44 < ppO ₂ ≤ 4.85	≤ 14 days

Revision: E	Document No: CxP 70024
Release Date: 11/19/10	Page: 30 of 503
Title: Constellation Program Human-Systems Integration Requirements	

<i>18.5 < ppO₂ ≤ 23.7</i>	<i>139 < ppO₂ ≤ 178</i>	<i>2.69 < ppO₂ ≤ 3.44</i>	<i>Nominal physiological range. Indefinite with no measurable impairments.²</i>
17.1 < ppO ₂ ≤ 18.5	128 < ppO ₂ ≤ 139	2.48 < ppO ₂ ≤ 2.69	Indefinite with measurable performance decrements. ³
14.8 < ppO ₂ ≤ 17.1	111 < ppO ₂ ≤ 128	2.15 < ppO ₂ ≤ 2.48	1 hour if acclimatized to 17.1 < ppO ₂ ≤ 18.5 kPa, otherwise risk acute mountain sickness. ⁴
ppO ₂ ≤ 14.8	ppO ₂ ≤ 111	ppO ₂ ≤ 2.15	Not allowed. Supplemental O ₂ is required to perform tasks without significant impairment.

NOTE:

1. Kilopascal (kPa) is the International System of Units (SI). Other units are for reference only.
2. Nominal pressure ranges are included for completeness and denoted by italic font. HS3004B is the requirement for nominal ppO₂.
3. The effects of ppO₂ between 17.1 kPa and 18.5 kPa include increased respiration and heart rate, and decreased mental alertness and capacity for physical work. After a 3-day crew exposure to this range, most effects will no longer be present and nominal human function will resume, although capacity for physical work may remain diminished for a longer period. There is no mechanism by which crewmembers can be acclimatized without these minor performance decrements, but the effects are diminished with slower ppO₂ adjustment times. Additionally, although the risk of AMS is very low in this ppO₂ range, it is not zero; the risk of AMS will be lower the more slowly that ppO₂ adjustments are made.
4. Rapid decreases in ppO₂ from the nominal range (18.5 < ppO₂ ≤ 23.7 kPa) to this range should be avoided. The 1-hour limit applies to crews that have acclimatized to the 17.1 < ppO₂ ≤ 18.5 kPa range for a minimum of 3 days.

Rationale: The ppO₂ minimum acceptable limits defined in HS3005B, table Partial Pressure Oxygen Physiological Limits for Crew Exposure are established to ensure adequate delivery of oxygen to the pulmonary alveoli from inspired oxygen ppO₂. These limits represent the minimum ppO₂ required to maintain the alveolar pressure of oxygen equivalent to that of breathing air at a range of altitudes from approximately 3,000- to 10,000-foot pressure altitude, at which degradation in performance is expected to occur with acute changes. The minimum limit of 17.1 kPa (2.48 psia or 128 mmHg) for indefinite O₂ partial pressure is set at approximately 6,000-ft altitude equivalent. This level is set below the 10,000-ft altitude level where oxygen masks are required per Federal Aviation Administration (FAA) and Department of Defense (DoD) requirements, and to reduce the likelihood of development of acute hypoxic symptoms, such as Acute Mountain Sickness (AMS). With continued exposure to less oxygen than stated in the table limits, especially with increasing level of activity, AMS may result. The limits are in accordance with international standards. Variations in total cabin pressure will affect the partial pressure of oxygen unless mixture adjustments are made. Russian standards for hypoxia limits allow exposure to

Revision: E	Document No: CxP 70024
Release Date: 11/19/10	Page: 31 of 503
Title: Constellation Program Human-Systems Integration Requirements	

16.0 kPa (2.32 psia) (120 mmHg) – 18.7 kPa (2.71 psia) (140 mmHg) O₂ for a maximum of 3 days. The lowest ppO₂ level in the HS3005B, table Partial Pressure Oxygen Physiological Limits for Crew Exposure represents an O₂ equivalent altitude (breathing air) of 10,000 feet. Rapid ascents to 10,000 feet cause a mild to moderate altitude sickness incidence in 20 to 40 percent of those ascending. The risk of altitude sickness is increased principally from the reduced alveolar oxygen ppO₂ and to a lesser degree from the decrease in the ambient air pressure. The 10,000-ft altitude equivalent (14.8 kPa ppO₂) represents the maximal altitude that DoD and commercial FAA pilots may fly without supplemental oxygen (accepted masking level). Molecular oxygen (O₂) can manifest toxic effects at high partial pressures. The maximum acceptable prolonged ppO₂ physiological exposure level is 23.7 kPa (3.44 psia) (178 mmHg) O₂. However, short-term exposure to elevated ppO₂ levels is usually well tolerated and should result in no adverse effects on crewmembers if kept within the exposure limits in the table. The exposure limits presented in the HS3005B, table Partial Pressure Oxygen Physiological Limits for Crew Exposure represent the physiological limitations for human occupants and do not consider engineering limitations, which may be imposed upon the system, including reduced maximal O₂ concentrations for purposes of fire hazard control. For compliance with other requirements, the system may operate at any combination of time and ppO₂ that does not exceed the limits in the table. Certain mission profiles will not allow ppO₂ to remain in the nominal physiological range (HS3004B) during all mission phases. Preparation for prolonged exposure to decreased oxygen should include a gradual lowering of ppO₂ (hours to days) to minimize hypoxic symptoms and allow for acclimatization. CxP 70000, CARD, ppO₂ requirement (CA3133-PO) (17 kPa [2.5 psia] to 21 kPa [3.1 psia]) accounts for post-acclimatization indefinite exposure to lower oxygen ppO₂ at the lower limit and fire hazard controls at the upper limit.

3.2.1.2.3 CO₂ Partial Pressure Tolerance Ranges for Crew Exposure

[HS3005C] The system shall maintain the partial pressure of carbon dioxide in the internal atmosphere to operate as defined in HS3005C, table Partial Pressure CO₂ Physiological Limits for Crew Exposure.

TABLE 3.2.1.2.3-1 - PARTIAL PRESSURE CO₂ PHYSIOLOGICAL LIMITS FOR CREW EXPOSURE

ppCO ₂ (kPa)	ppCO ₂ (mmHg) [1]	Time Allowed in Area Using Inspired ppCO ₂ [2]	Time Allowed in Module Using Module Sensor
NOMINAL [3]			
0.0–0.67	0.0–5.0	indefinite	indefinite
SUBOPTIMAL			

Revision: E	Document No: CxP 70024
Release Date: 11/19/10	Page: 32 of 503
Title: Constellation Program Human-Systems Integration Requirements	

0.67–0.71	> 5.0–5.3	30 days	7 days
0.71–0.80	> 5.3–6.0	7 days	24 hours
0.80–1.01	> 6.0–7.6	24 hours	8 hours
1.01–1.33	> 7.6–10	8 hours	4 hours
OFF-NOMINAL AND EMERGENCY [4]			
1.33–2.00	> 10.0–15	4 Hours	1 hour
2.00–2.67	> 15.0–20.0	2 hours	30 minutes
2.67–4.00	> 20.0–30.0	30 minutes	Do not exceed
4.00–5.33	> 30.0–40.0	Do not exceed	Do not exceed
5.33–10.1	> 40.0–76	Danger Zone	Danger Zone
>10.1	>76.0	Emergency	Emergency

NOTES:

1. Partial Pressure of CO₂ (Carbon Dioxide)
2. Partial Pressure of CO₂ (Carbon Dioxide as measured at the point of inspiration)
3. Nominal pressure ranges are included for completeness and denoted by italic font. HS3004C is the requirement for nominal pp CO₂.
4. Return ppCO₂ to nominal levels for a minimum of 8 hours to reset the time allowed at off-nominal levels. Without an 8-hour interval at nominal CO₂ levels, count all suboptimal and off-nominal exposure as cumulative.

Rationale: There is no minimum CO₂ requirement for human existence; however, blood levels of CO₂ may be driven to impaired function levels by hyperventilation as observed during states of hypoxia. Maximum: The NASA SMAC for 24 hours TWA is 1.32 kPa (0.19 psia) (9.9 mmHg), from JSC 20584, Spacecraft Maximum Allowable Concentrations for Airborne Contaminants; however, it is 2.00 kPa (0.29 psia) (15 mmHg) for 1 hour exposures. The US Navy allows 2.47 kPa (0.36 psia) (18.5 mmHg) up to 24 hours with very mild and reversible symptoms beyond this exposure period. The constraints and actions within HS3005C, table Partial Pressure CO₂ Physiological Limits for Crew Exposure were based on limits established by federal agency and national standard documents including the NASA SMACs and the Russian "State Standard" (referred to as GOST). The only sources of CO₂ on the ISS are human respiration and combustion episodes. Rates of rise of CO₂ will be slow and predictable based on calculated respiration rates and number of crewmembers on board. High levels of CO₂ are unlikely to be reached acutely unless an off-nominal event (e.g., fire) has occurred, which will be associated with other more toxic compounds being elaborated into the common atmosphere. Humans usually can adapt to slow elevation rates of CO₂ exposure, and thereby a reduction in the number and severity of symptoms may be observed; however, if the level of CO₂ reaches the levels listed in HS3005C, table Partial Pressure CO₂ Physiological Limits for Crew Exposure, then symptoms and/or performance decrements will be observed. There may be increased sensitivity to carbon dioxide or other atmospheric pollutants during spaceflight, relative to terrestrial

Revision: E	Document No: CxP 70024
Release Date: 11/19/10	Page: 33 of 503
Title: Constellation Program Human-Systems Integration Requirements	

conditions, associated with Space Adaptation Syndrome (SAS) or physiologic alterations associated with 0-g adaptation, hence a need to set limits more conservatively than those found in terrestrial applications. The difference between the time allowed between the local versus the module sensors is due to the local accumulation of CO₂ in various regions of the vehicle that occur, and an uncertain disparity between what is being measured at the module sensor location, versus what the crewmember is actually breathing where they are located. The intent for including module sensor values is to provide daily averages. For inspired ppCO₂, local sensors are intended to be more time sensitive than a 24-hour time weighted average; it is either hourly or, for worst case, every 8 hours.

3.2.1.3 Control, Display and Alerting of Atmospheric Parameters

3.2.1.3.1 O₂ and Total Pressure Control

[HS3001] The system shall provide for the adjustment of total pressure and ppO₂ by the crew and Constellation Systems within the ranges described in HS3004 and HS3004B.

Rationale: To ensure a safe habitable atmosphere for the crew when communications with Constellation Systems, including other vehicles and Mission Systems, is unavailable, atmospheric parameters must be controllable by the crew.

3.2.1.3.2 Composition Reporting

[HS3013] The system shall display measurements of total pressure, partial pressure oxygen, and partial pressure carbon dioxide to the crew.

Rationale: Various procedures will require detailed knowledge by the crew of the values of total pressure, partial pressure oxygen, and partial pressure carbon dioxide in the vehicle's atmosphere. Examples may include ISS docking, contingency EVA prebreathe, and loss of pressure procedures.

3.2.1.3.3 Composition Alerting

[HS3014] The system shall generate an alert when total pressure, ppO₂, ppCO₂, or ppN₂ exceed the limits specified by HS3004, HS3004B, HS3004C, HS3004D, HS3005, HS3005B, and HS3005C.

Rationale: Various procedures (e.g., a loss of pressure emergency procedure) will be initiated based on the values of major constituents in the vehicle's atmosphere. Alerting removes the need for the crew to constantly monitor these atmospheric parameters during periods when there is no communications with Mission Operations (MO): during communication outages or loss-of-signal.

Revision: E	Document No: CxP 70024
Release Date: 11/19/10	Page: 34 of 503
Title: Constellation Program Human-Systems Integration Requirements	

3.2.1.4 Contaminants

3.2.1.4.1 Microbial Air Contamination

[HS3006] The system shall limit the levels of microbial contaminants by maintaining an average continuous flow of 20 cubic feet per minute (CFM) or greater per person of air that has been cleaned to have at least 99.97% of airborne particles 0.3 micrometers (μm) and larger in diameter/size removed.

Rationale: Microbial limits for breathing air are designed to prevent infection and allergic response. Requirements are based upon industrial hygiene recommendations for similar environments (American Society of Heating, Refrigerating and Air-Conditioning Engineers (ASHRAE-62)). Limitations on fungi and bacteria in spacecraft are consistent with previous requirements, such as SSP 50260, Revision C, ISS Medical Operations Requirements Document (MORD). ISS air systems relied on High Efficiency Particulate Air (HEPA) filter design to provide clean air, which has performed exceptionally well in controlling atmospheric microbial concentrations. This requirement doesn't apply to suited operations.

3.2.1.4.2 Particulate Contamination

[HS3006C] The system shall limit the concentration in the cabin atmosphere of particulate matter ranging from 0.5 micron to 100 microns in aerodynamic diameter to $<0.2 \text{ mg/m}^3$ with a crew generation rate of 0.09 mg/person-minute.

Rationale: Inhalation of particulates can cause irritation of the respiratory system. Limits for particulates are based on OSHA standards. Crew generation rates are based on a study that addressed particulate matter generated from people with a focus on skin fragments, sneezes, coughs, clothing fibers, metallics, hair, paint chips, plastics, and miscellaneous items that included tissue, food, yarn, woven and glass tape, finger nail clippings, and pencil lead. Study results are documented in NASA/TP-1998-207978, Elements of Spacecraft Cabin Air Quality Design, Table 9 and were used as the basis for ISS High Efficiency Particulate Air (HEPA) filter design, which has performed exceptionally well in controlling atmospheric microbial concentrations.

3.2.1.4.3 Lunar Dust Contamination

[HS3006D] The system shall limit the levels of lunar dust contaminants of less than 10 and equal to or greater than 0.1 micron $<\text{TBR-70024-004}>$ size in the internal atmosphere to below 0.05 mg/m^3 .

Rationale: Lunar dust poses a hazard in addition to that from ordinary particulates. This limit is a 180-day (6-month episodic exposure) limit and is based on a minimum currently expected permissible limit, as estimated by the Lunar Atmosphere Dust Toxicity Assessment Group (LADTAG). The final value

Revision: E	Document No: CxP 70024
Release Date: 11/19/10	Page: 35 of 503
Title: Constellation Program Human-Systems Integration Requirements	

for this lunar dust limit will be provided by the LADTAG in 2010. This requirement is not applicable to initial capability, only to lunar.

3.2.1.5 Gaseous Pollutants Limits

3.2.1.5.1 Gaseous Pollutants Limits

[HS3007] The system shall limit individual gaseous pollutant concentrations in the habitable volume to below long-term limits described in JSC 20584, Spacecraft Maximum Allowable Concentrations (SMAC) for Airborne Contaminants.

Rationale: Safe air pollutant levels are established specifically for human-rated space vehicles by the Johnson Space Center (JSC) Toxicology Group in cooperation with a subcommittee of the National Research Council Committee on Toxicology. Design consideration and analysis, which have been used previously to achieve the values in the SMACs, are outlined in NASA/TP-1998-207978, Elements of Spacecraft Cabin Air Quality Design. Historical methods used to achieve these values included a combination of air scrubbing, materials control (e.g., using NASA-STD-6001, Flammability, Odor, Off-Gassing, and Compatibility Requirements and Test Procedures for Materials in Environments that Support Combustion) and containment of system chemicals.

3.2.1.6 Rate of Change of Pressure Limits

3.2.1.6.1 Rate of Change of Pressure Limits

[HS3009] The system shall limit exposure of the crew to the rate of change of total internal pressure to between -207 kPa (-30.0 psi) (-1,550 mmHg)/min and +93.1 kPa (+13.5 psi) (+698 mmHg)/min during nominal operations.

Rationale: The rate of change of pressure must be limited to prevent injury to the crew's ears and lungs during depressurization and re-pressurization. These are physiological limits: it is expected that pressure changes will be effected more slowly than this where possible. The positive rate of change limit is designed to prevent barotraumas in spaceflight conditions where microgravity may have affected head and sinus congestion and is therefore much more conservative than the 310 kPa (45.0 psi) (2,330 mmHg)/minute (100 feet/minute) descent rate allowed by the US Navy dive manual limit. The negative rate of change limit is consistent with the US Navy dive manual 66 feet/minute ascent rate allowance. This limit is for rate of change in pressure. However, the magnitude must still be limited to prevent DCS. The magnitude change allowed will be based on starting pressure and prebreathe accomplished.

3.2.1.7 Combustion Products

3.2.1.7.1 Combustion Products Measurement

[HS3012B] The system shall provide a real time capability for the measurement of atmospheric concentrations of toxic combustion products in the following ranges:

Revision: E	Document No: CxP 70024
Release Date: 11/19/10	Page: 36 of 503
Title: Constellation Program Human-Systems Integration Requirements	

carbon monoxide (CO) from 5 to 500 ppm, hydrogen cyanide (HCN) from 1 to 50 ppm, and hydrogen chloride (HCl) from 1 to 50 ppm.

Rationale: The crew must be able to measure the concentrations of the combustion products listed in the requirement to determine the correct course of action after a combustion event to mitigate risk to crew health. References: TR-915-001 (White Sands Test Facility (WSTF), 14 May 1998) Evaluation of Compound Specific Analyzer-Combustion Products (CSA-CP), pp. 1-12; Space Physiology and Medicine (1994) Thermo-degradation of materials (pp. 147-8); International Conference on Environment Systems (ICES) Paper 2005-01-2872 "An Environmental Sensor Technology Selection Process for Exploration" [Table 1].

3.2.1.7.2 Combustion Products Monitoring

[HS3012A] The system shall provide a real time capability to monitor and display atmospheric concentrations of the toxic combustion products: carbon monoxide (CO), hydrogen cyanide (HCN), and hydrogen chloride (HCl) in the habitable volume.

Rationale: Combustion events can present an immediate threat to the life of the crew because of the release of CO, HCN, and HCl. The consequences of pyrolysis events during spaceflight are significant; therefore, a means is required to manage crew exposures to toxic compounds after a fire and to assess atmospheric decontamination.

3.2.1.7.3 Carbon Monoxide Alert

[HS3012D] The system shall alert the crew when the carbon monoxide (CO) concentrations exceed the lower limits in HS3012B.

Rationale: As the consequences of pyrolysis events during spaceflight are significant, the crew must be made aware if CO levels are above acceptable levels defined in HS3012B.

3.2.1.8 Hazardous Chemicals

3.2.1.8.1 Toxic Hazard Level 3

[HS3015] The system shall use only chemicals that are Toxic Hazard Level 3 or below, as defined in Appendix C, table Criteria for Assignment of Toxicological Hazard Levels, in the habitable volume of the vehicle.

Rationale: Toxic hazard Level 4 compounds, which are defined in Appendix C, table Criteria for Assignment of Toxicological Hazard Levels, can pose an immediate risk to crew health and cannot be scrubbed from the environment. The prevention of Toxic Hazard Level 4 chemicals from being used in the habitable atmosphere will decrease the crew health risk to these chemicals.

Revision: E	Document No: CxP 70024
Release Date: 11/19/10	Page: 37 of 503
Title: Constellation Program Human-Systems Integration Requirements	

3.2.1.8.2 Toxic Hazard Level 4

[HS3015A] The system shall prevent Toxic Hazard Level 4 chemicals, as defined in Appendix C, table Criteria for Assignment of Toxicological Hazard Levels, from entering the habitable volume of the vehicle.

Rationale: Toxic Hazard Level 4 compounds, which are defined in Appendix C, table Criteria for Assignment of Toxicological Hazard Levels, can pose an immediate risk to crew health and cannot be scrubbed from the environment. These compounds include substances that: (1) are considered extremely hazardous to the crew and a release of the substance will not allow for crew survival (via escape or isolation), and/or (2) cause permanent damage to life support systems to the extent that they are unable to maintain the atmosphere at a marginally acceptable level, and/or (3) cannot be removed from the atmosphere by the life support systems or the life support systems cannot restore the atmosphere to marginally acceptable levels in 1 week. The prevention of Toxic Hazard level 4 chemicals from entering the habitable atmosphere from an external source will decrease the crew health risk to these chemicals.

3.2.1.8.3 Decomposition of Chemicals

[HS9037] The system shall use only chemicals that, if released into the habitable volume, do not decompose into hazardous compounds that threaten crew health during all phases of operations.

Rationale: Only a few compounds have been shown to decompose into hazardous compounds during nominal Atmosphere Revitalization System operations on the Shuttle, but these compounds could present a toxic threat if the amount of the compound involved is sufficient and the product compound is hazardous. Halon is an example of such a chemical; if it is sufficiently heated during its normal use as a fire suppressant, it breaks down into highly toxic gaseous compounds.

3.2.1.9 Crew Protection

3.2.1.9.1 Personal Protective Equipment

[HS3016] The system shall provide Personal Protective Equipment (PPE) for each crewmember in the event of an emergency.

Rationale: Spaceflight experience has shown that all airborne toxic risks cannot be completely controlled; therefore, the crew must have access to individual protective equipment in the event of failure of other controls. This equipment may include but is not limited to masks, goggles, gloves, eyewash, and contingency breathing apparatus. Reference SSP 50653-1, Basic Provisions on Crew Actions in the Event of a Toxic Release on the ISS, Section 13.0, "Personal

Revision: E	Document No: CxP 70024
Release Date: 11/19/10	Page: 38 of 503
Title: Constellation Program Human-Systems Integration Requirements	

Protective Equipment," p. 33. In an emergency, this equipment must be near-to-hand and quickly accessible.

3.2.1.9.2 Contingency Breathing Apparatus

[HS3017A] The system shall provide each member of the crew a contingency breathing apparatus, which provides breathable air that meets the quality specifications defined in HS3004B, HS3004C, and HS3004D.

Rationale: In the case of a medical or off-nominal condition, each crewmember will require delivery of uncontaminated and appropriate oxygen containing breathing gas. This requirement does not apply to suited operations.

3.2.1.9.3 Crew Communication During Contingency Breathing

[HS3017] The system shall provide voice communication between all crewmembers when wearing the contingency breathing apparatus.

Rationale: Wearing a contingency breathing apparatus may hinder clear communication between crewmembers, which is essential during an emergency.

3.2.1.9.4 Mission Systems Communication During Contingency Breathing

[HS3017B] The system shall provide voice communication between the crew and Mission Systems when wearing the contingency breathing apparatus.

Rationale: Wearing a contingency breathing apparatus may hinder clear communication between the crew and Mission Systems, which is necessary to provide vehicle and crew status.

3.2.2 Potable Water

3.2.2.1 Potable Water Quality

3.2.2.1.1 Physiochemical Limits for Potable Water

[HS3019] The system shall provide potable water at or below the physiochemical limits of HS3019, table Potable Water Physiochemical Limits at the point of crew consumption.

Revision: E	Document No: CxP 70024
Release Date: 11/19/10	Page: 39 of 503
Title: Constellation Program Human-Systems Integration Requirements	

TABLE 3.2.2.1.1-1 - POTABLE WATER PHYSIOCHEMICAL LIMITS

Taste	3	TTN
Odor	3	TON
Turbidity	1	NTU
Color, True	15	PCU
Free & Dissolved Gas ¹	5	%
Acidity (pH)	4.5–9.0	N/A
Chemical		
Ammonia ²	1	mg/L
Antimony	0.006	mg/L
Arsenic	0.01	mg/L
Barium ²	10	mg/L
Cadmium ²	0.022	mg/L
Chloride	250	mg/L
Chlorine	4	mg/L
Chromium	0.23	mg/L
Copper	1.0	mg/L
Cyanide	0.2	mg/L
Fluoride	2	mg/L
Iron	0.3	mg/L
Lead	0.05	mg/L
Manganese ²	0.3	mg/L
Mercury	0.002	mg/L
Nickel ²	0.3	mg/L
Nitrate (as Nitrogen, NO ₂ -N)	10	mg/L
Nitrite (as Nitrogen, NO ₃ -N)	1.0	mg/L
Potassium	340	mg/L
Selenium	0.01	mg/L
Silver ²	0.4	mg/L
Sulfate	250	mg/L
Total Dissolved Solids	500	mg/L
Total Iodine ³	0.2	mg/L
Zinc ²	2.0	mg/L
Total Organic Carbon ²	3	mg/L
Acetone ²	15	mg/L
Alkylamines (di) ²	0.3	mg/L
Alkylamines (mono) ²	2	mg/L
Alkylamines (tri) ²	0.4	mg/L
Caprolactum ²	100	mg/L
Chloroform ²	6.5	mg/L
Di(2-ethylhexyl) phthalate ²	20	mg/L

Revision: E	Document No: CxP 70024
Release Date: 11/19/10	Page: 40 of 503
Title: Constellation Program Human-Systems Integration Requirements	

Di-n-butyl phthalate ²	40	mg/L
Dichloromethane ²	15	mg/L

Revision: E	Document No: CxP 70024
Release Date: 11/19/10	Page: 41 of 503
Title: Constellation Program Human-Systems Integration Requirements	

POTABLE WATER PHYSIOCHEMICAL LIMITS (CONCLUDED)

Formaldehyde ²	12	mg/L
Formate ²	2,500	mg/L
2-Mercaptobenzothiazole ²	30	mg/L
Phenol ²	4	mg/L
n-Phenyl-beta-naphthylamine ²	260	mg/L
Semi-volatile Organic Compounds listed in EPA Method 625	EPA MCL4,5	mg/L
Volatile Organic Compounds listed in EPA 524.2, Rev. 4	EPA MCL4,5	mg/L

NOTES:

1. Free gas at vehicle atmospheric pressure and 98.6 °F, dissolved gas saturated at vehicle atmospheric pressure and 98.6 °F.
2. 1,000-day SWEG in JSC 63414, Spacecraft Water Exposure Guidelines (SWEG).
3. Derived from the total iodine intake limits specified in Shuttle Flight Rule A13-30.
4. Environmental Protection Agency (EPA) Maximum Contamination Level (MCL).
5. If a compound has both a SWEG and EPA MCL, the SWEG value takes precedence.

Rationale: Safe water pollutant levels have been either established specifically for human-rated space vehicles by the JSC Toxicology Group in cooperation with a subcommittee of the National Research Council Committee on Toxicology or are based on Maximum Contaminant Levels (MCL) established by the United States Environmental Protection Agency (EPA). Point of crew consumption or contact refers to the location from which potable water is dispensed for use in drinks, food rehydration, health (medical), hygiene, and any potential in-flight maintenance sites. These values should be used as the water quality design limits and are appropriate for protecting crew exposures up to 1,000 days. From an operational standpoint, mission-specific exceptions may be relevant for certain chemicals if the total duration of crew spaceflight exposure (i.e., Orion exposure + lunar habitat exposure, or Orion exposure + ISS exposure) does not exceed 100 days. This requirement is only applicable to FCE if FCE provides stored potable water.

3.2.2.1.2 Microbial Limits for Potable Water

[HS3019A] The system shall provide potable water that maintains water quality at or below the microbial limits of HS3019A, table Potable Water Microbial Limits at the point of crew consumption or contact.

TABLE 3.2.2.1.2-1 - POTABLE WATER MICROBIAL LIMITS

Characteristic	Maximum Allowable	Units
Bacterial Count	50	CFU/mL
Coliform Bacteria	Non-detectable per 100 mL	-
Fungal Count	Non-detectable per 100 mL	-
Parasitic Protozoa (e.g., <i>Giardia</i> and <i>Cryptosporidium</i>)	0	-

Rationale: Microbially safe water is essential to prevent infection and mitigate risk to crew health and performance. These limits are consistent with those defined by the JSC Microbiology Laboratory and in the ISS MORD. On the ISS, maintenance of these specifications during operation has been accomplished using flow through a 0.2-micron filter and use of a residual biocide. Point of crew consumption or contact refers to the location from which potable water is dispensed for use in drinks, food rehydration, health (medical), hygiene, and any potential in-flight maintenance sites. This requirement is only applicable to FCE if FCE provides stored potable water.

3.2.2.2 Potable Water Quantity

3.2.2.2.1 Potable Water for On-Orbit Drinking

[HS3025] The system shall provide a minimum of 2.0 L (67.6 fl oz) of potable water per crewmember per mission day for drinking.

Rationale: The amount of drinking water required to maintain crewmember hydration status and allow crewmembers to perform duties nominally is 2.0 L. This quantity is also required for adequate urine output to clear metabolic wastes and to account for perspiratory and other insensible losses. Intake less than 2.0 L will increase the risk of under hydration or dehydration of the crewmember, with consequences ranging from poor communication and crew performance due to dry mucous membranes, nosebleeds, headache, malaise and fitful sleep, to urinary tract infection or urinary calculi if the under-hydration state is continued. Additionally, a loss of body weight due to dehydration has been shown to raise body temperature from 0.1-0.23 °C for each 1% of body weight lost. Dehydration also cancels many of the thermal benefits of heat acclimatization and aerobic fitness. Considering the thermal stresses that may be encountered during the post-landing period, adequate hydration must be assured. This amount does not include potable water requirements for other purposes such as rehydrating food, personal hygiene, medical treatment, pre-loading for re-entry, and post-landing consumption.

Revision: E	Document No: CxP 70024
Release Date: 11/19/10	Page: 43 of 503
Title: Constellation Program Human-Systems Integration Requirements	

3.2.2.2.2 Potable Water for On-Orbit Food Rehydration

[HS3127] The system shall provide a minimum of 500 mL (16.9 fl oz) of potable water per crewmember per mission day for food rehydration.

Rationale: The minimum 500 mL is based on current ratios of thermostabilized, freeze dried, and natural form foods from the ISS menu. This amount does not include potable water requirements for other purposes such as drinking, personal hygiene, medical treatment, pre-loading for re-entry, and post-landing consumption. If the ratio of thermostabilized, freeze-dried, and natural form foods is revised, the water requirement would be adjusted appropriately.

3.2.2.2.3 Potable Hot Water Quantity for Rehydration

[HS3118] The system shall provide 600 mL (20.3 fl oz) of hot water per person per meal for four crewmembers at the temperature required in HS3031.

Rationale: This requirement defines the expected amount of hot water necessary for a crewmember meal per the Space Food Systems Laboratory. Average hot water needed for a crewmember meal is dependent on whether a food warmer is present or not. This water quantity is included in HS3025, Potable Water Onorbit Drinking and HS3127, Potable Water Onorbit Food Rehydration, not in addition to HS3025 and HS3127. The in-flight food preparation time needed for a crewmember meal is specified in HS6005 and HS6102.

3.2.2.2.4 Potable Water for Personal Hygiene

[HS3028] The system shall provide a minimum of 400 mL (13.5 fl oz) of potable water per crewmember-day for personal hygiene.

Rationale: Clean water is necessary for maintaining skin, hair, and dental health of crewmembers. Some of this water quantity can be met with the water in pre-wetted towels.

3.2.2.2.5 Potable Water for Medical Use

[HS3122] The system shall provide 500 mL (16.9 fl oz) of potable water for eye irrigation per crewmember for nominal particulate events (dust and Foreign Object Debris [FOD]).

Rationale: Eye irrigation is required for spaceflight based on experience and data from shuttle, ISS, and Apollo programs. Eye wash capability for particulate events is expected especially for lunar missions due to the increased risk of exposure to dust on the lunar surface and after transfer from the surface into the Orion. The volume in the medical use requirement will provide water for two particulate event eye washes per crewmember, which is an anticipated rate of likelihood.

Revision: E	Document No: CxP 70024
Release Date: 11/19/10	Page: 44 of 503
Title: Constellation Program Human-Systems Integration Requirements	

3.2.2.2.6 Potable Water for Medical Contingency

[HS3123] The system shall provide 5.0 L (169 fl oz) of potable water for medical contingency use (e.g., chemical exposure/burn).

Rationale: Water for medical contingency use is required for many situations including eye and wound irrigation during spaceflight based on experience and data from shuttle, ISS, and Apollo programs. Some medical situations require much larger quantities of water than those stated in HS3122 (Potable Water for Medical Use); for example, LiOH or other Tox Level 2+ substances in the eye or skin wound. However, these events are off-nominal and occur at lower frequency than the particulate events during the mission and may be considered contingencies.

3.2.2.2.7 Potable Water for EVA Operations

[HS6063] The system shall provide an additional 240 mL (8.12 fl oz) of potable water per hour above nominal potable water provision, as defined in HS3025, for crewmembers performing EVA operations.

Rationale: Potable water is necessary during suited operations to prevent dehydration due to perspiration and insensible water loss, as well as to improve crew comfort. The additional 240 mL (8.12 oz) is based upon measured respiratory and perspiratory losses during suited operations. During a lunar EVA, crewmembers will most likely be suited for 10 hours, with approximately 7 of those hours expending energy on the lunar surface. Apollo Summit strongly recommended the availability of this quantity of water for consumption during a lunar EVA.

3.2.2.2.8 Potable Water for Fluid Loading

[HS3026] The system shall provide a minimum of 1.0 L (33.8 fl oz) of potable water per crewmember for re-entry fluid loading countermeasures for each End-of-Mission (EOM) opportunity.

Rationale: The 1.0 L (33.8 fl oz) quantity is based on Shuttle Aeromedical flight rule for re-entry fluid loading, which requires 1.5 L (50.7 fl oz) initial fluid loading; however, 0.5 L (16.9 fl oz) of which will come from unconsumed daily water allocation per crewmember. This allocation protects for nominal End of Mission (EOM) fluid loading plus one additional wave-off opportunity 24 hours later. Without this additional water allocation, the crew may have inadequate water available to fluid load and thus have hemodynamic compromise during and after deorbit. Having inadequate fluid loading will almost certainly cause physiological difficulties in some, if not most, crewmembers. A small, indefinable percentage will become temporarily incapacitated and it is not inconceivable that a significantly hypovolemic crewmember in a contingency could perish when he/she otherwise would not have. For low earth orbital missions, protect for

Revision: E	Document No: CxP 70024
Release Date: 11/19/10	Page: 45 of 503
Title: Constellation Program Human-Systems Integration Requirements	

EOM and EOM+1. Lunar direct return does not need EOM+1 protection for fluid loading.

3.2.2.2.9 Potable Water for Post-Landing

[HS3027] The system shall provide a minimum of 1.0 L (33.8 fl oz) of potable water per crewmember for each 8-hour period of the entire crew recovery period, with 500 mL of this total water allotment readily and immediately accessible by each seated and restrained crewmember during the first 2-hours of post-landing activities.

Rationale: The system shall provide a minimum of 1.0 L (33.8 fl oz) per 8-hour period for 24 hours of potable water per crewmember for crew consumption after landing. Orion will protect for a 24-hour post-landing recovery (ref. CA-PO0194), which will therefore require a total of 3.0 L (101 fl oz) of potable water for a dehydrated crewmember. For the earth launch abort scenario, only 830 mL (28.1 fl oz) per 8-hour period for up to 24 hours (1.49 L [84.2 fl oz]) is required since in an abort scenario crew have not undergone the fluid loss of spaceflight therefore less water is required to maintain acceptable hydration state. Because the nominal operation concept assumes crew will remain seated and restrained until recovery by ground recovery forces, 500 mL of this total water allotment must be readily and immediately accessible by each seated and restrained crewmember during the first 2-hours of post-landing activities. This requirement is only applicable to FCE if FCE provides stored potable water for post-landing use.

3.2.2.3 Potable Water Delivery

3.2.2.3.1 Potable Water Rate

[HS3029] The system shall provide potable water to the crew at a rate of not less than 500 mL/minute (16.9 oz/minute).

Rationale: This rate also ensures that the crew will be able to prepare for and perform tasks (i.e., filling drink bags and rehydrating food) that require potable water in a reasonable amount of time. The requirement is based upon a maximum of 30 seconds between fills. This rate requirement is not intended to require an additional water quantity beyond that required for nominal mission water usage. This flow rate is not applicable to hot water. The hot water flow rate will be based on task analyses that consider HS6005 "In Flight Food Preparation Time."

3.2.2.3.2 Potable Water Dispensing

[HS3117] The system shall provide the capability to dispense water in 15 mL (0.51 fl oz) increments between the quantities of 30 mL (1.01 fl oz) and 240 mL (8.12 fl oz), with an accuracy of +/- 5.0 mL (0.17 fl oz) at 30 mL (1.01 fl oz), +/- 10 mL (0.34 fl oz) between 45-90 mL (1.52-3.04 fl oz), and +/- 10% between 105-240 mL (3.55-8.12 fl oz).

Revision: E	Document No: CxP 70024
Release Date: 11/19/10	Page: 46 of 503
Title: Constellation Program Human-Systems Integration Requirements	

Rationale: Measured amounts of water must be added to the food for proper hydration. The 15 mL (0.51 fl oz) increment provides the ability to accurately meter the water based on current freeze-dried foods and beverages. Accuracy requirements reflect current ISS Potable Water Dispenser requirements. The amount of water that may be used for medical contingencies is not intended to be in addition to the water required for nominal mission water usage.

3.2.2.4 Potable Water Temperature

3.2.2.4.1 Potable Water Temperature for Cold Drinks

[HS3030] The system should provide cold water at a maximum temperature of 15.6 °C (60 °F) for missions longer than 3 days.

Rationale: This water is to be used to rehydrate cold drinks.

3.2.2.4.2 Potable Water Temperature for Hot Food and Drinks

[HS3031] The system shall provide hot water at a temperature between 68.3 °C (155 °F) and 79.4 °C (175 °F).

Rationale: This water is to be used to rehydrate food requiring hot water. Water at a temperature of 79.4 °C (175 °F) allows for the temperature of the food to still remain above 68.3 °C (155 °F), which prevents microbial growth. The higher water temperature also allows for better rehydration of the foods and beverages.

3.2.2.4.3 Potable Water Temperature for Personal Hygiene

[HS3032] The system should provide personal hygiene water at a temperature between 29.4 °C (85 °F) and 46.1 °C (115 °F).

Rationale: This temperature range is required to support body cleansing.

3.2.2.4.4 Potable Water Temperature for Medical Use

[HS3121] The system shall provide potable water for medical events at a temperature between 18 °C (64.4 °F) and 28 °C (82.4 °F).

Rationale: The temperature range is required to prevent thermal injury to the tissues during irrigation.

3.2.2.5 Water Sampling

3.2.2.5.1 Water Sampling

[HS3034] The system shall provide access to potable water systems for the collection of water samples during ground processing, in-flight, and post-landing for contamination assessment.

Rationale: Rigorous ground processing with pre-flight water sampling and contamination assessment prevents in-flight water quality problems, and thus minimizes the need for in-flight contamination monitoring and remediation of any

Revision: E	Document No: CxP 70024
Release Date: 11/19/10	Page: 47 of 503
Title: Constellation Program Human-Systems Integration Requirements	

water quality parameters that are out of specification. Ground-based quality analyses of in-flight and post-landing samples provide a record of crew exposure and are used to determine follow-on ground processing steps. In-flight sampling capability will also support real-time contaminant monitoring and remediation of stored or regenerated water systems as needed for long-duration lunar or Mars missions.

3.2.3 Thermal Environment

This section provides requirements for atmospheric temperature, humidity, dew point, and airflow.

3.2.3.1 Atmospheric Temperature and Heat Stored by Crewmembers

3.2.3.1.1 Nominal Atmospheric Temperature

[HS3036] The system shall maintain the atmospheric temperature within the range of 18 °C (64.4 °F) to 27 °C (80.6 °F) during all nominal flight operations, excluding suited operations, ascent, entry, landing, and post-landing.

Rationale: Human comfort without the use of thermal protective garments requires this fairly narrow temperature range. The comfort zone is defined as the range of environmental conditions in which humans can achieve thermal comfort and not have their performance of routine activities affected by thermal stress. Thermal comfort is affected by the work rate, clothing, and state of acclimatization. A graphical representation of the comfort zone as provided in Appendix E, figure Environmental Comfort Zone. The comfort zone does not include the entire range of conditions in which humans can survive indefinitely: this is a larger zone that might require active perspiration or shivering, and these responses are initiated by elevated or lowered core temperatures. The graph implies minimal air movement and assumes the radiant temperature of the surroundings to be equal to the dry bulb temperature. The effects of acclimatization, work, and heavier clothing are shown as data trends by the arrows on the graph. This temperature range has been used successfully for Space Transportation System (STS) and ISS vehicular operations.

3.2.3.1.2 Contingency Control of Heat Stored by Crewmembers

[HS3037] The Constellation Architecture (CA) shall prevent the energy stored by each crewmember from exceeding the Cognitive Deficit Onset (CDO) limits defined by the range, 4.7 kJ/kg (2.0 BTU/lb) > ΔQ stored > -4.1 kJ/kg (-1.8 BTU/lb), during ascent, entry, descent, landing, post-landing, off nominal flight operations, and suited operations longer than 12 hours, where ΔQ stored is calculated using the 41-Node man or Wissler model.

Rationale: This requirement is intended to cover brief temperature excursions due to contingency situations including excessively high metabolic rates or operational exposure to excessive ambient heat loads. Every effort should be

Revision: E	Document No: CxP 70024
Release Date: 11/19/10	Page: 48 of 503
Title: Constellation Program Human-Systems Integration Requirements	

made to keep crewmembers within a more narrow comfort zone of heat stored (Appendix E), including during microgravity EVA, as specified in HS11002. Calculation of heat accumulation or rejection (ΔQ stored) is per 41-Node man or Wissler model. The ΔQ stored limits are plotted in Appendix E, figure Heat Storage to graphically show the boundaries of the human heat accumulation or rejection tolerance. Heat accumulation rationale: A vehicular cabin with excess heat load may quickly reach crew tolerance limits and may impair crew performance and health. Crew impairment begins when skin temperature increases greater than 1.4 °C (2.5 °F) (0.6 °C [1 °F] core) or if pulse is greater than 140 bpm. Precise prediction of crew tolerances and time constraints for entry is not possible; therefore, environmental temperature must be controlled. Appendix E, table Core Temperature Range Limits and Associated Performance Decrements, identifies core temperature range limits and associated performance decrements. Keeping the crewmember heat storage value below the performance impairment line allows the crew the ability to conduct even complex tasks without heat-induced degradation. In a non-acclimatized individual, water loss is approximately 0.95 L (32 oz) per hour and salt loss is approximately 2 to 3 grams (0.0044 to 0.0066 lb) per hour. In microgravity and elevated humidity, sweat forms an insulating layer over the body, further adding to the heat stress instead of relieving it. If the crewmember is in a suit, the heat load may increase rapidly. JSC thermoregulatory models (Wissler and 41-Node man) simulating hot cabin entries wearing launch and entry suits with the properties of the Advanced Crew Escape Suit (ACES) (thickness, conductance, wickability, and emissivity) predicted loss of all body cooling mechanisms. Supporting data from military aircrew protective ensembles suggest body temperature may increase more rapidly over time in ACES, compared to a shirt-sleeve environment. Heat rejection rationale: If heat is removed from the body to the point of thermogenic shivering, crew task performance will be impaired in a similar fashion to excess heat storage. Like the condition of excess heat storage, which can be mitigated by specialized cooling garments, excess heat rejection can be mitigated to some degree by the use of insulating garments. Appendix E, figure Environmental Comfort Zone shows the effect of tolerance to cold temperature and wind by the addition of varying degrees of thermal protecting clothing. Keeping the crewmember heat rejection value above the performance impairment line in Appendix E, figure Heat Storage, allows the crew to conduct tasks without cold-induced degradation. This requirement will be met by integrated systems with the details of each system's responsibility defined in individual system SRDs and in IRDs.

3.2.3.2 Relative Humidity

3.2.3.2.1 Relative Humidity for Nominal Vehicle

[HS3046] The system shall maintain the average relative humidity level over each 24-hour period between 25 and 75 percent during all crewed flight operations, excluding suited operations less than 4 hours and post-landing.

Revision: E	Document No: CxP 70024
Release Date: 11/19/10	Page: 49 of 503
Title: Constellation Program Human-Systems Integration Requirements	

Rationale: Average humidity must be maintained above this lower limit to ensure that the environment is not too dry for the nominal functioning of mucous membranes and to prevent static electricity build-up within the cabin, which could pose an increased electrical hazard to the crew. Average humidity must be maintained below this upper limit for crew comfort and to limit formation of condensation. Excess moisture in the glove can contribute to trauma at the fingertips. Suited operations less than 4 hours include any EVA done from the Orion, ascent, entry, landing, and nominal IVA operations. This requirement is applicable to lunar surface EVA and to survival IVA.

3.2.3.2.2 Relative Humidity Tolerance Ranges for Crew Exposure

[HS3126] The system shall restrict human exposure to humidity levels according to HS3126, table Relative Humidity Tolerance Ranges during suited operations less than 4 hours and during nominal post-landing.

TABLE 3.2.3.2.2-1 - RELATIVE HUMIDITY TOLERANCE RANGES

Average Relative Humidity	Time Allowed
≤5%	1 hour
>5% - 15%	2 hours
>15 - 25%	4 hours
>25 – 75%	Indefinite*
>75 – 85%	24 hours**
>85 – 95%	12 hours**
>95%	8 hours**

NOTE: Nominal humidity range is included for completeness. HS3046 is the requirement for nominal humidity ranges.
* Assumes temperature is within nominal range
** Only after doffing a suit post-landing; duration may be shorter if temperature is outside nominal range

Rationale: The intent of this requirement is to apply to umbilical EVAs from Orion and to post-landing. Average humidity must be maintained above the lower limits stated to ensure that the environment is not too dry for the nominal functioning of mucous membranes. If humidity is not maintained above the lower limits, additional water must be provided to the crew to prevent dehydration. Humidity must be maintained below the upper limits for crew comfort, to allow for effective evaporation, and to limit the formation of condensation. Excess moisture in the glove can contribute to trauma at the fingertips. During umbilical use, the suit depends on the vehicle to provide life support. Excess Relative Humidity (RH) in the cabin post-landing requires the suit to be doffed to enable cooling of the body. If the temperature is elevated, high RH may interfere with the nominal evaporation process that enables perspiration to cool the body. Thus high RH can pose a hazard for core body temperature excess. For vehicle off-nominal, post-landing exposures >8 hrs, requirement HS3037 or HS11002 applies.

Revision: E	Document No: CxP 70024
Release Date: 11/19/10	Page: 50 of 503
Title: Constellation Program Human-Systems Integration Requirements	

3.2.3.3 Ventilation

3.2.3.3.1 In-flight Ventilation

[HS3047] The system shall maintain a ventilation rate within the internal atmosphere such that two-thirds (66.7%) of the atmosphere velocities are between 4.57 m/min (15 ft/min) and 36.58 m/min (120 ft/min), except during suited operations, toxic cabin events, or when the crew is not inhabiting the vehicle.

Rationale: Crew and equipment give off heat, moisture, and CO₂ that will lead to parameters outside the bounds of environmental requirements if adequate ventilation is not provided. Maintaining proper ventilation within the internal atmosphere is necessary to ensure that stagnant pockets do not form, and the temperature, humidity, and atmospheric constituents are maintained within their appropriate ranges. Similar values have been used on ISS. Exceptions and more detail on ventilation rate measurement are listed in the verification requirement. The two-thirds value for atmosphere velocities in the requirement has historically proven to be a reasonable balance between design constraints such as power, acoustics, and safety. The effective atmosphere velocity range of 4.57-36.58 m/min (15-120 ft/min) pertains to the time averaged velocity magnitudes in the crew occupied space using averages over time periods sufficient to achieve stability. This range is considered sufficient to provide circulation that prevents CO₂ and thermal pockets from forming. Cabin ventilation is not required during suited operation since the suit will provide necessary air circulation. Fire or any toxic release into the atmosphere are examples of periods during which the mentioned ventilation rates are not in the best interest of air quality and crew health. In those cases, the ventilation system may need to be shut down in order to protect the safety of the crew.

3.2.3.3.2 Supplemental Ventilation

[HS3050] Local ppO₂, ppCO₂, and relative humidity shall be controlled as defined in HS3005B, table Partial Pressure Oxygen Physiological Limits for Crew Exposure; HS3005C, table Partial Pressure CO₂ Physiological Limits for Crew Exposure; and HS3046 for temporary maintenance activities in areas not in the normal habitable volume.

Rationale: The crew may be required to perform maintenance behind a panel in an area that is not part of the normal habitable volume, and which therefore does not have ventilation. Maintaining proper ventilation within the internal atmosphere is necessary to ensure that stagnant pockets do not form and the temperature, humidity and atmospheric constituents are maintained within their appropriate ranges. Examples of historical ventilation techniques include equipment such as flexible (reconfigurable) ducting, portable fans, or diverters.

Revision: E	Document No: CxP 70024
Release Date: 11/19/10	Page: 51 of 503
Title: Constellation Program Human-Systems Integration Requirements	

3.2.3.4 User Control of Atmospheric Thermal Properties

3.2.3.4.1 Temperature Set-Point Increments

[HS3053] The system shall provide temperature set-points in increments of 1 °C (1.8 °F) or less between the operational temperatures defined in HS3036.

Rationale: An important factor in crew comfort is the maintenance of a comfortable cabin temperature. A 1 °C (1.8 °F) increment is sufficient to maintain crew comfort.

3.2.3.4.2 Temperature Set-Point Adjustment

[HS3051] The system shall allow the crew to adjust the atmospheric temperature within the limits defined in HS3036, with the minimal allowable range of adjustability between 21 °C (69.8 °F) and 27 °C (80.6 °F), inclusive.

Rationale: Individual comfort preferences and workload variations dictate that the set points for the temperature can be set by the crew.

3.2.3.4.3 Temperature Set-Point Error

[HS3054] The system shall control temperature to +/-1.5 °C (2.7 °F) of the set point of the operational temperatures defined in HS3036.

Rationale: Individual comfort preferences and workload variations dictate that temperature be controllable within this range as described in the paragraphs in HS3047, In-flight Ventilation. 1.5 °C (2.7 °F) precision is sufficient to maintain crew comfort.

3.2.3.4.4 Temperature Set-Point Accessibility

[HS3052] Atmospheric temperature set-point control shall be accessible to at least one crewmember during all nominal operations, including times when the crew is restrained.

Rationale: The crew will need to control the atmospheric temperature during all flight phases to ensure crew comfort for mission success.

3.2.3.4.5 Ventilation Adjustment

[HS3114] The system shall allow the crew to adjust the ventilation delivery to the cabin.

Rationale: The ability to control local cabin ventilation by adjusting the direction of air flow will enable the crew to prevent exhaled, CO₂-rich air from building around the head (i.e., adjust for too-little ventilation), and to prevent drying of facial mucous membranes (i.e., adjust for too much ventilation). Each Constellation vehicle will have unique ventilation characteristics; therefore, the specific adjustment settings will be individually defined for each vehicle, and will be stated in child requirements in lower level documents.

Revision: E	Document No: CxP 70024
Release Date: 11/19/10	Page: 52 of 503
Title: Constellation Program Human-Systems Integration Requirements	

3.2.3.5 Atmosphere Thermal Properties Monitoring

3.2.3.5.1 Display of Actual Temperature

[HS3115] The system shall display actual temperature with a display step size of 1 °C (1.8 °F).

Rationale: An accurate display of temperature is required for crew reference in altering the cabin environment.

3.2.3.5.2 Display of Temperature Set-Point

[HS3116] The system shall display the temperature set-point with a display step size of 1 °C (1.8 °F).

Rationale: An accurate display of temperature set-point is required for crew reference in altering the cabin environment.

3.2.3.5.3 Display and Monitoring of Temperature and Relative Humidity

[HS3055] The system shall measure, record, and display temperature and relative humidity to the crew.

Rationale: Temperature and humidity are critical parameters in crew health and comfort. The ability of the crew to track these data in a real time fashion prevents environmental conditions that could harm the crew or the vehicle.

3.2.4 Acceleration

This section presents the requirements for sustained and transient linear and rotational accelerations as well as occupant protection. Accelerations are defined using the coordinate system shown in Appendix C, figure Acceleration Environment Coordinate System and table Direction and Inertial Resultant of Body Acceleration. The calculation of component linear accelerations includes

linear accelerations that are induced by rotational velocities, and centripetal accelerations that are induced by rotational velocities.

Sustained accelerations, linear or rotational, are events with a duration of greater than 0.5 second. Transient accelerations, linear or rotational, are events with a duration of less than or equal to 0.5 second.

To convert from acceleration of free fall, standard (gn) to meter per second squared (m/s²) multiply by 9.80665 (National Institute of Standards and Technology (NIST) Special Publication (SP) 811, 1995 Edition). Occupant protection requirements in this document are included to control hazards presented by excessive crew loads due to high accelerations or insufficient crew restraint. An additional hazard mode that may threaten occupant safety is structural failure, especially during off-nominal landing events. It is important that both hazard elements be controlled in order to minimize crew injury during vehicle acceleration and deceleration events.

Revision: E	Document No: CxP 70024
Release Date: 11/19/10	Page: 53 of 503
Title: Constellation Program Human-Systems Integration Requirements	

Structural failure (primary or secondary) may present an occupant protection hazard through impinging upon occupant volume in such a way as to injure crewmembers. In order to protect against this hazard, it is necessary to define a "crew occupiable volume," or "survivable volume", that cannot be breached and, through hazard analysis and other methods, ensure that vehicle structure, subsystems, and components do not create critical or catastrophic hazard risks through entering this volume. It is also important to ensure that implementation of protections against these hazards do not impede egress or otherwise create unintended additional risks. This type of hazard is protected against through CxP 72000, Constellation Program System Requirements for the Orion System, with Table 3.2.2-1 defining certified landing conditions and impact condition probability criteria. This hazard is also protected against through CxP 70135, Constellation Program Structural Design and Verification Requirements.

3.2.4.1 Sustained Linear Acceleration

These requirements apply to sustained, linear accelerations, measured at the heart.

3.2.4.1.1 Crew Exposure to Rate of Change of Acceleration

[HS3059] The system shall prevent the crew from being exposed to a rate of change of acceleration of more than 500 g/s during any sustained acceleration event.

Rationale: Acceleration onset rates greater than 500 g/s significantly increase the risk of crew incapacitation, thereby threatening crew survival.

3.2.4.1.2 Linear Acceleration Limits during Nominal Return

[HS3060] The system shall prevent the crew from being exposed to linear accelerations greater than those depicted by the dotted/green lines in HS3060, figures + G_x Linear Sustained Acceleration Limits, - G_x Linear Sustained Acceleration Limits, + G_z Linear Sustained Acceleration Limits, - G_z Linear Sustained Acceleration Limits, and +/- G_y Linear Sustained Acceleration Limits.

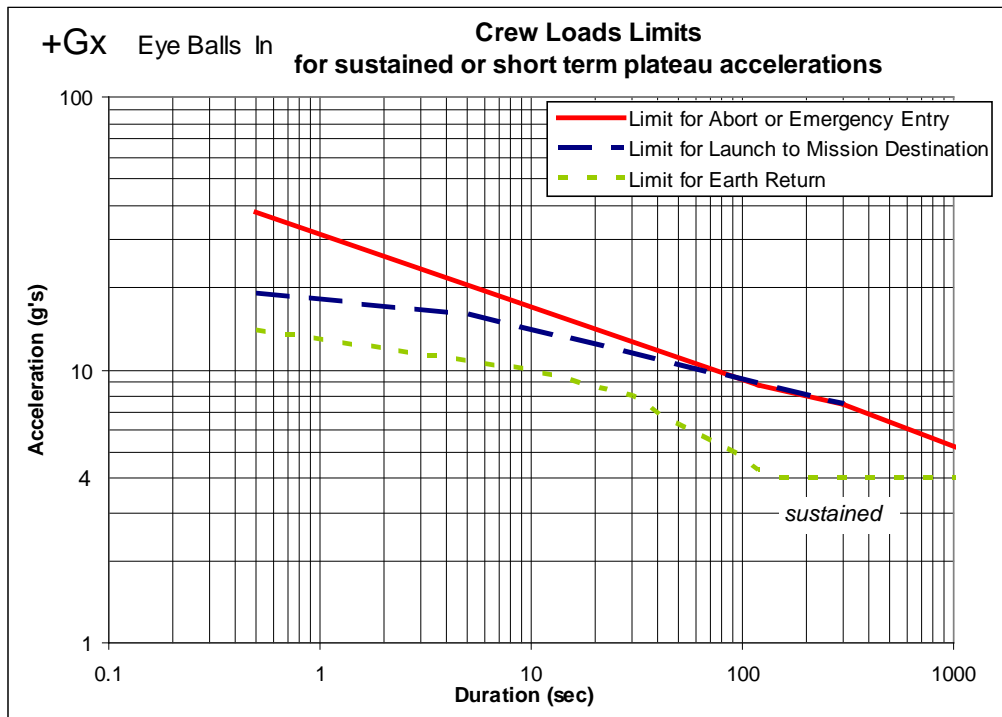


FIGURE 3.2.4.1.2-1 - + G_x LINEAR SUSTAINED ACCELERATION LIMITS

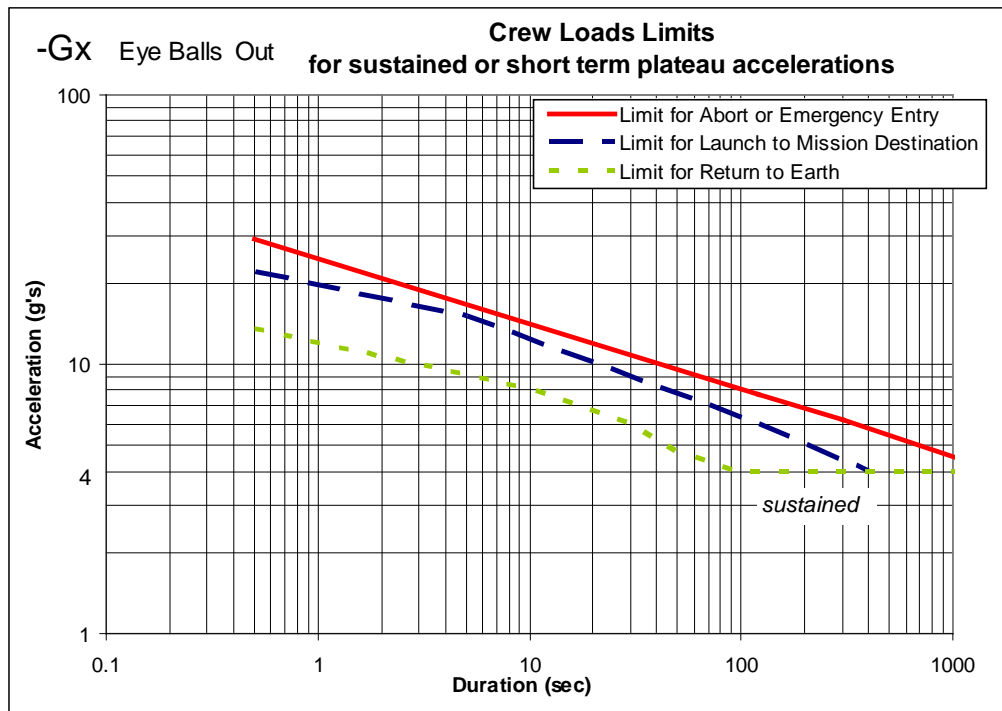


FIGURE 3.2.4.1.2-2 -- G_x LINEAR SUSTAINED ACCELERATION LIMITS

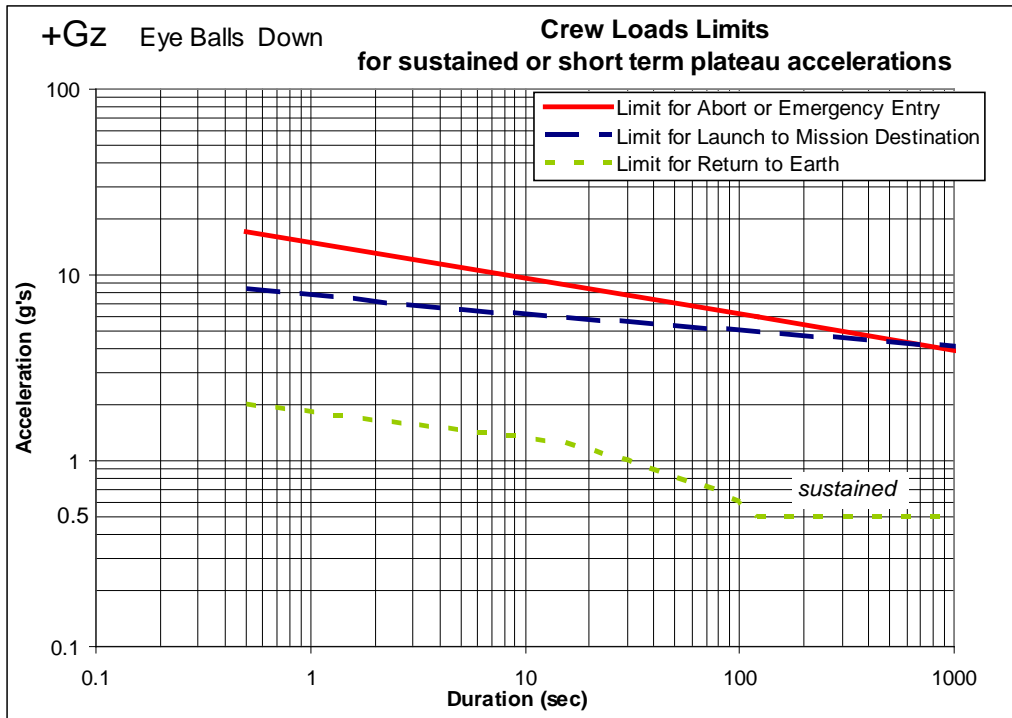


FIGURE 3.2.4.1.2-3 - - G_z LINEAR SUSTAINED ACCELERATION LIMITS

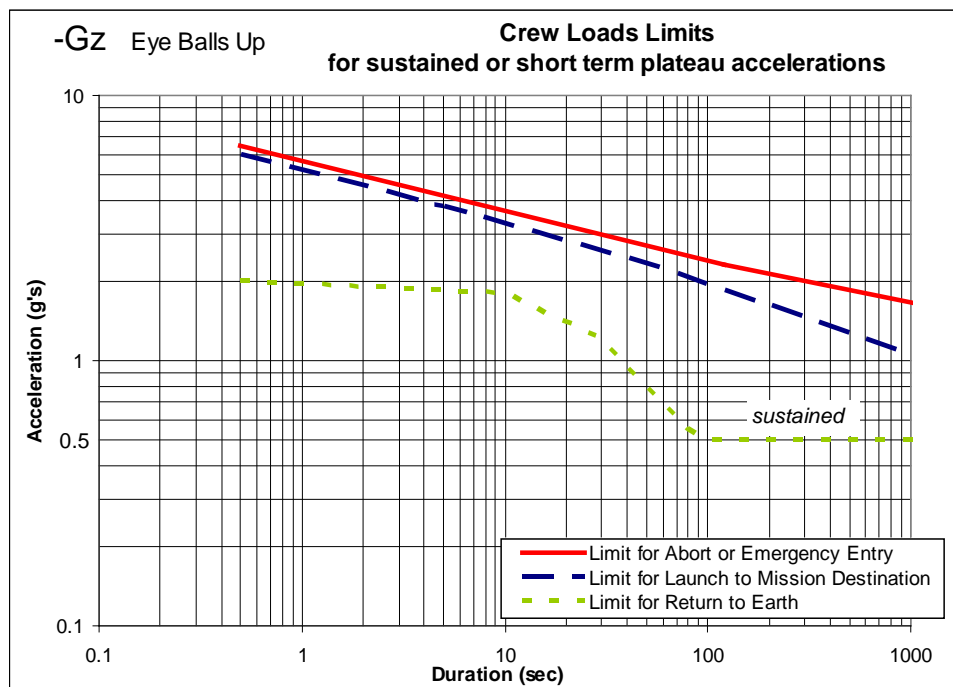


FIGURE 3.2.4.1.2-4 - - G_z LINEAR SUSTAINED ACCELERATION LIMITS

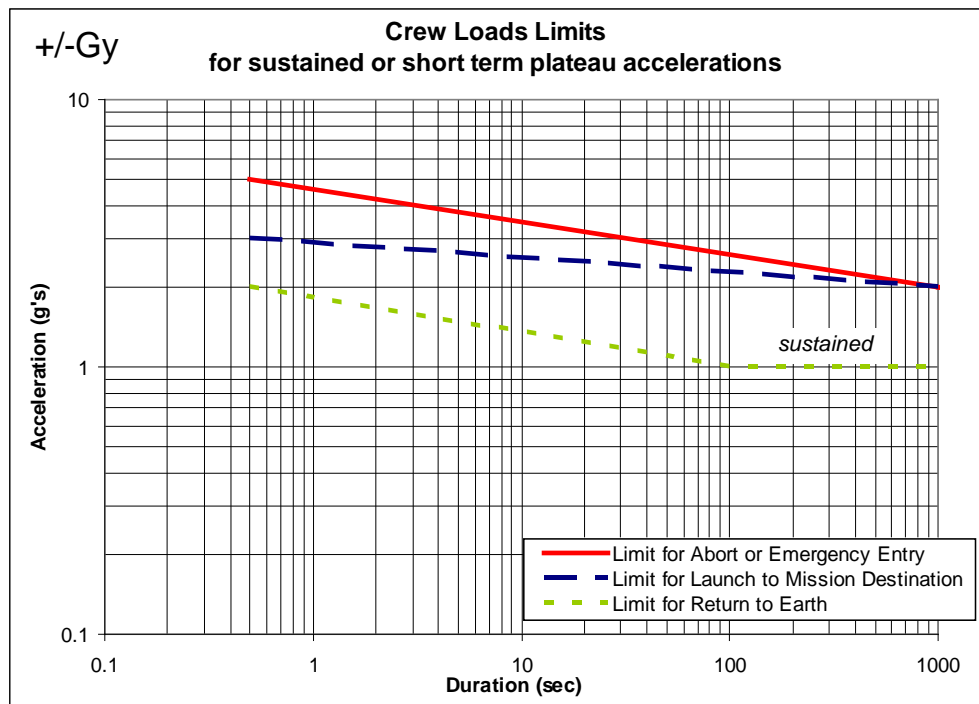


FIGURE 3.2.4.1.2-5 - +/- G_y LINEAR SUSTAINED ACCELERATION LIMITS

Rationale: The dotted/green lines in HS3060, figures + G_x Linear Sustained Acceleration Limits, - G_x Linear Sustained Acceleration Limits, + G_z Linear Sustained Acceleration Limits, - G_z Linear Sustained Acceleration Limits, and +/- G_y Linear Sustained Acceleration Limits represent the maximum level of sustained acceleration allowed on a crewmember after sustained exposure to a reduced or microgravity environment, after an injury, or during an illness. After working at the mission destination, crewmembers could have degraded capabilities because of the pathophysiology of being deconditioned from exposure to reduced gravity and therefore should not be exposed to accelerations higher than those depicted by the dotted/green lines in the charts. Greater exposure to g-forces could significantly affect human performance and safety. The lower dotted/green limits also accommodate returning ill or injured crewmembers. Each axis is to be analyzed separately, and conservatism in the limits for each axis covers any cumulative effect of acceleration in multiple axes.

3.2.4.1.3 Linear Acceleration Limits from Launch to Mission Destination

[HS3061] The system shall prevent the crew from being exposed to linear accelerations greater than those depicted by the dashed/blue lines in HS3060, figures + G_x Linear Sustained Acceleration Limits, - G_x Linear Sustained Acceleration Limits, + G_z Linear

Revision: E	Document No: CxP 70024
Release Date: 11/19/10	Page: 57 of 503
Title: Constellation Program Human-Systems Integration Requirements	

Sustained Acceleration Limits, - G_z Linear Sustained Acceleration Limits, and +/- G_y Linear Sustained Acceleration Limits from launch to mission destination.

Rationale: The dashed/blue lines in HS3060, figures + G_x Linear Sustained Acceleration Limits, - G_x Linear Sustained Acceleration Limits, + G_z Linear Sustained Acceleration Limits, - G_z Linear Sustained Acceleration Limits, and +/- G_y Linear Sustained Acceleration Limits represent the maximum level of sustained acceleration allowed on a conditioned crewmember under nominal conditions. These crewmembers should not be exposed to higher acceleration limits depicted by the dashed/blue lines in the figures. Exposure to g-forces greater than these limits could significantly affect human performance for maneuvering and interacting with the spacecraft. Each axis is to be analyzed separately, and conservatism in the limits for each axis covers any cumulative effect of acceleration in multiple axes. This requirement can be met by integrated systems with the details of each system's responsibility in individual system SRDs and IRDs.

3.2.4.1.4 Linear Acceleration Limits for Ascent Abort and Off-Nominal Entry

[HS3062] The system shall prevent the crew from being exposed to linear accelerations greater than those depicted by the solid/red lines in HS3060, figures + G_x Linear Sustained Acceleration Limits, - G_x Linear Sustained Acceleration Limits, + G_z Linear Sustained Acceleration Limits, - G_z Linear Sustained Acceleration Limits, and +/- G_y Linear Sustained Acceleration Limits during a launch abort or emergency entry.

Rationale: The solid/red lines in HS3060, figures + G_x Linear Sustained Acceleration Limits, - G_x Linear Sustained Acceleration Limits, + G_z Linear Sustained Acceleration Limits, - G_z Linear Sustained Acceleration Limits, and +/- G_y Linear Sustained Acceleration Limits represent the maximum level of sustained acceleration allowed on a crewmember during a launch abort or emergency entry. Under these extreme conditions, it may be necessary to expose the crew to accelerations more severe than those experienced nominally (see dashed blue lines), but crewmembers should never be exposed to accelerations greater than those depicted by the solid/red lines in the figures. Exceeding these elevated limits could significantly increase the risk of crew incapacitation, thereby threatening crew survival. Each axis is to be analyzed separately, and conservatism in the limits for each axis covers any cumulative effect of acceleration in multiple axes.

3.2.4.2 Occupant Protection

3.2.4.2.1 Crew Injury Risk Limits

[HS3064] The Constellation Architecture shall limit the injury risk criterion, β , to no greater than 1.0 according to the Brinkley Dynamic Response model in Appendix N, table Dynamic Response Limits.

Revision: E	Document No: CxP 70024
Release Date: 11/19/10	Page: 58 of 503
Title: Constellation Program Human-Systems Integration Requirements	

Rationale: The Brinkley Dynamic Response model will provide an injury risk assessment during dynamic phases of flight for accelerations less than 0.5 second. Application of this model assumes that the crew will be similarly restrained during all events where the Brinkley model is applied, as explained in Appendix N. Human tolerance for injury risk limits for development of space vehicles that are based on human volunteer impact test data and operational emergency escape system experience, such as the Brinkley criterion, have been adjusted for landing impact after re-entry considering existing knowledge of the physical and physiological deconditioning due to long-term exposure to the microgravity of space. The large experience in human testing of aircraft ejection seats and operational experience with emergency escape systems has enabled the highest fidelity for injury prediction, using the Brinkley model in the G_z axis. Although the maximum allowable Brinkley β value is 1.0 for any given level of risk, the vehicle occupant protection system design should strive to achieve β values as low as reasonably achievable for as many of the landing conditions and scenarios as possible. The criteria include dynamic response limits that have been established for varying probabilities of injury. This model may primarily be used for landing scenarios, but it is applicable for all dynamic phases of flight for accelerations less than 0.5 second. Application of the Brinkley Dynamic Response model is described in NASA-TM-2008-215198, The Use of a Vehicle Acceleration Exposure Limit Model and a Finite Element Crash Test Dummy Model to Evaluate the Risk of Injuries During Orion Crew Module Landings. Structural failure may present an occupant protection hazard through impinging upon occupant volume in such a way as to injure crewmembers. This type of hazard is protected against through CxP 70135, Constellation Program Structural Design and Verification Requirements, Section 3.

3.2.4.2.2 Head Protection Criteria

[HS3124] The Constellation Architecture should limit the Head Injury Criteria (HIC) as defined per HIC 15 to values specified in Appendix N, table Head Injury Criteria.

Rationale: Keeping HIC 15 to less than values in Appendix N, table Head Injury Criteria significantly reduces head injury. These values are derived based on acceleration at the head. Blunt impacts, sharp edges and other sources of trauma may lead to head injuries and, therefore, should be considered in the design of head protection; however, it is not the intent of this requirement to control these additional factors. Structural failure may present an occupant protection hazard through impinging upon occupant volume in such a way as to injure crewmembers. This type of hazard is protected against through CxP 70135, Constellation Program, Structural Design and Verification Requirements, Section 3. The HIC 15 is calculated using the formula in Appendix N3.0 and is limited to values in Appendix N, table Head Injury Criteria for each 15-millisecond interval. Historical implementation of this requirement has found the majority of the head protection comes from design and implementation of protective features of the crew helmet. Historically, to achieve the intended purpose, head protection

Revision: E	Document No: CxP 70024
Release Date: 11/19/10	Page: 59 of 503
Title: Constellation Program Human-Systems Integration Requirements	

includes headrest systems that have continuously smooth surfaces without sharp edges to prevent penetration injury to the head and neck. This requirement needs to be considered for both suited and unsuited scenarios. The appropriate risk level will be determined by the Projects and concurred by the Program.

3.2.4.2.3 Head Transient Acceleration Limits

[HS3132] The Constellation Architecture should limit transient linear accelerations to the head to those specified in Appendix N, table Head Acceleration Limits.

Rationale: Limiting the accelerations applied to the head significantly reduces the likelihood of traumatic brain injury and injury to the skull and cervical spine. Historically, the peak head acceleration has been a key driver in the design and materials selection for the conformal elements within the flight helmet to prevent abrupt contact with the helmet. This requirement needs to be considered for both suited and unsuited scenarios. The appropriate risk level will be determined by the Projects and concurred by the Program.

3.2.4.2.4 Neck Protection Criteria

[HS3125] The Constellation Architecture should limit the bending moments applied to the neck to those specified in Appendix N, table Neck Protection Criteria.

Rationale: Limiting the cervical flexion and extension bending moments to those in Appendix N, table Neck Protection Criteria significantly reduces the likelihood of cervical spinal fracture or injury to soft tissues around the cervical spine. Neck bending moments are influenced by both seat and helmet/suit design features. The appropriate risk level will be determined by the Projects and concurred by the Program.

3.2.4.2.5 Transient Force Application Limits

[HS3128] The Constellation Architecture should limit the transient forces applied to the crew to those specified in Appendix N, table Transient Force Application Limits <TBD-70024-005>.

Rationale: Limiting the forces applied to the cervical spinal elements will significantly reduce the risk of spinal fracture as well as soft tissue injury around the spinal elements. Limitation of force applied to the body also protects internal organs and vasculature from injury. The application of an optimized restraint system and the use of energy attenuation methods may work in tandem to limit these transient loads to the vehicle occupant's body, especially the head and neck. Keeping the crew's neck under the tension, compression, and shear force limits may require the implementation of a head and neck restraint system similar to that used in the automotive industry. Structural failure may present an occupant protection hazard through impinging upon occupant volume in such a way as to injure crewmembers. This type of hazard is protected against through CxP 70135, Constellation Program Structural Design and Verification

Revision: E	Document No: CxP 70024
Release Date: 11/19/10	Page: 60 of 503
Title: Constellation Program Human-Systems Integration Requirements	

Requirements, Section 3. The appropriate risk level will be determined by the Projects and concurred by the Program.

3.2.4.2.6 Chest Deflection

[HS3129] The Constellation Architecture should limit the deflection of the crewmember's chest to the values specified in Appendix N, table Restrained Body Movement and Deflection <TBR-70024-001>.

Rationale: Limiting chest deflection (defined as the inward depression of the sternum toward the spinal column in the x-axis) lowers the likelihood of internal thoracic injury such as pneumothorax, cardiac or pulmonary contusion, rib fracture, etc. Implementation of this requirement will mainly be a function of the seat and restraint system design. Structural failure may present an occupant protection hazard through impinging upon occupant volume in such a way as to injure crewmembers. This type of hazard is protected against through CxP 70135, Constellation Program Structural Design and Verification Requirements, Section 3.

3.2.4.2.7 Restrained Body Movement

[HS3130] The Constellation Architecture shall limit the crew body movement relative to the seat, while seated and restrained, to those specified in Appendix N, table Restrained Body Movement and Deflection <TBR-70024-001>.

Rationale: Human survivability during dynamic phases of flight requires implementing restraint principles in order to prevent relative body component movement and adverse dynamic overshoot that may result. Dynamic overshoot is a complex phenomenon involving material and tissue elasticity, geometry, mass distribution, natural frequency of the occupant, and seat and restraint properties. Examples of historically employed restraint principles can be found in Appendix N. The appropriate risk level will be determined by the Projects and concurred by the Program.

3.2.4.2.8 Flail Injury Protection

[HS5012] The Constellation Architecture shall prevent flail injury to restrained crewmembers during dynamic mission phases.

Rationale: During dynamic flight phases there is potential for extremity flail injury, which includes crewmember extremities impacting vehicular surfaces or objects, hyperextending, hyperflexing, hyper-rotating, fracturing, or dislocating if proper restraints are not used. Features such as harnesses, form-fitting seats, and tethers may help maintain the proper position of the crewmember's body and limbs to reduce movement or contact with vehicle surfaces that would produce flail injury. In addition, the design of the suit may contribute to reducing flail injury to the crew. Preventing the inadvertent contact of extremities with vehicular structure or interior components will significantly reduce the likelihood of limb

Revision: E	Document No: CxP 70024
Release Date: 11/19/10	Page: 61 of 503
Title: Constellation Program Human-Systems Integration Requirements	

fracture or soft tissue injury during a dynamic flight event. Extremity guards, tethers, garters, and hand holds have been used to reduce extremity flail in other spacecraft, aircraft, and automotive vehicles. Limiting the limb range of motion to the range of motion limits specified in Appendix B, table Unsuiting Joint Mobility reduces the likelihood of hyperextending, hyperflexing, and hyper-rotating the limbs.

3.2.4.3 Rotational Acceleration Limits

3.2.4.3.1 Sustained Rotational Acceleration Limit

[HS3065] The Constellation Architecture shall prevent the crew from being exposed to sustained rotational accelerations greater than 115 degrees/s².

Rationale: Crewmembers are not expected to be able to tolerate sustained rotational accelerations in excess of 115 degrees/s² without significant discomfort and disorientation. This requirement will be met by integrated systems with the details of each system's responsibility in individual system SRDs and in IRDs.

3.2.4.4 Rotational Rates

3.2.4.4.1 Rotational Limits for Nominal Return

[HS3069] The system shall prevent the crew from being exposed to yaw, pitch, or roll rates greater than those depicted by the dotted/green line in HS3071, figure Angular Rate Limits from mission destination to Earth landing.

Rationale: Yaw, pitch, and roll rates are rotations about the body's z-, y-, and x-axes respectively, as shown in Appendix C, figure Acceleration Environment Coordinate System. These limits apply to all three axes and are conservative for yaw rates. Deconditioned, ill or injured crewmembers are not expected to be able to tolerate sustained spin rates in excess of 5 to 8 rpm for extended periods of time. In addition, crewmembers outside the spin axis may experience large undesirable centripetal forces in several vectors dependent upon the spin rate, orientation, and distance from the axis of rotation. Therefore, returning crewmembers (potentially deconditioned, injured, or ill) should not be exposed to rotation rates greater than the more conservative limits depicted by the dotted/green line in the HS3071, figure Angular Rate Limits. This could significantly affect human performance on entry, landing, and egress.

3.2.4.4.2 Rotational Limits for Launch to Mission Destination

[HS3070] The Constellation Architecture shall prevent the crew from being exposed to yaw, pitch, or roll rates greater than those depicted by the dashed/blue lines in HS3071, figure Angular Rate Limits from launch to mission destination.

Rationale: Yaw, pitch, and roll rates are rotations about the body's z-, y-, and x-axes respectively, as shown in Appendix C, figure Acceleration Environment Coordinate System. These limits apply to all three axes and are conservative for

yaw rates. The dashed/ blue line in HS3071, figure Angular Rate Limits represents the maximum level of sustained ascent rotational rates allowed on a conditioned crewmember under nominal conditions. Under nominal conditions, conditioned crewmembers should not be exposed to rotation rates greater than the limits depicted by the dashed/blue line in the figures. This could significantly affect human performance for maneuvering and interacting with the spacecraft. This requirement will be met by integrated systems with the details of each system's responsibility in individual system SRDs and in IRDs.

3.2.4.4.3 Rotational Limits for Ascent Abort and Off-Nominal Entry

[HS3071] The system shall prevent the crew from being exposed to yaw, pitch, or roll rates greater than those depicted by the solid/red line in HS3071, figure Angular Rate Limits during a launch abort or emergency entry.

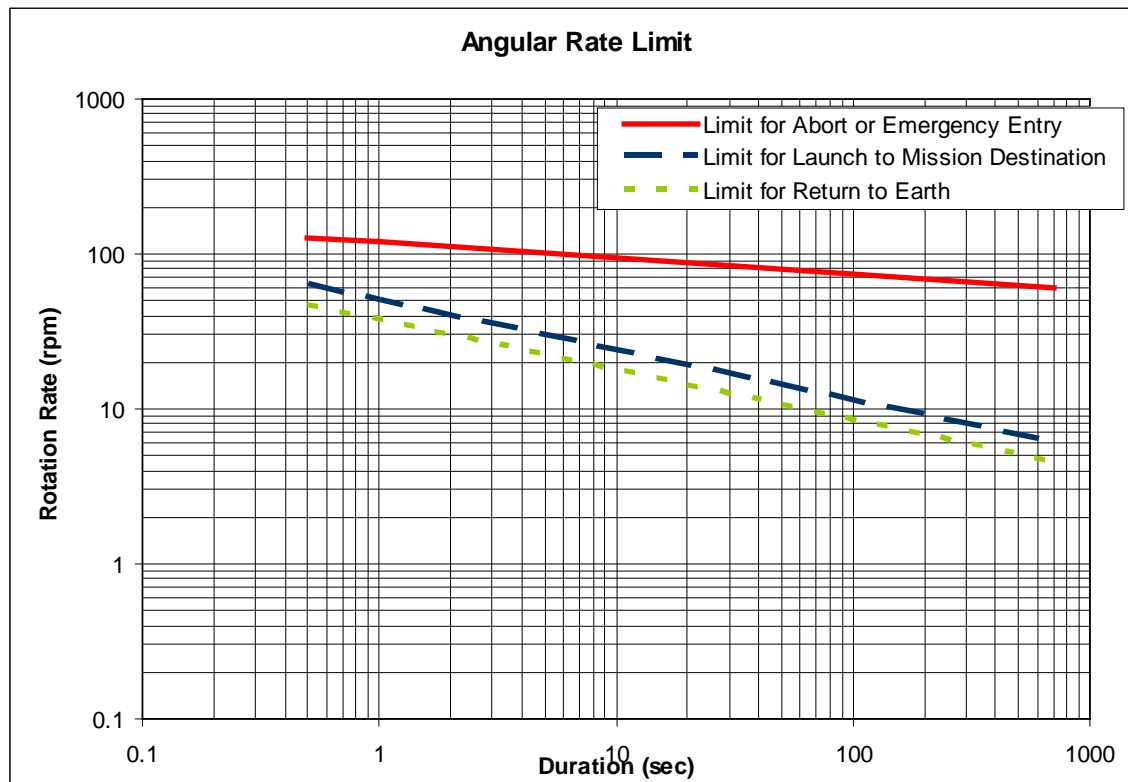


FIGURE 3.2.4.4.3-1 - ANGULAR RATE LIMITS

Rationale: Yaw, pitch, and roll rates are rotations about the body's z-, y-, and x-axes respectively, as shown in Appendix C, figure Acceleration Environment Coordinate System. These limits apply to all three axes and are conservative for yaw rates. The solid/red line in HS3071, figure Angular Rate Limits represents the maximum level of sustained ascent rotational rates allowed on a conditioned crewmember in a launch abort or emergency entry. Under these extreme conditions, it may be necessary to expose the crew to rotation rates more severe

Revision: E	Document No: CxP 70024
Release Date: 11/19/10	Page: 63 of 503
Title: Constellation Program Human-Systems Integration Requirements	

than those experienced nominally (see dashed/blue line), but crewmembers should never be exposed to rotation rates greater than the elevated limits depicted by the solid/red line in the figures. This could significantly increase the risk of crew incapacitation or survivability.

3.2.5 Vibration

This section contains requirements to ensure that vibration to the crew does not cause injury during periods of acceleration, and does not negatively impact crew habitability during sustained, low-level vibration exposure.

This section presents the requirements for vibration using the X, Y, Z coordinate system defined in Appendix C, figure Acceleration Environment Coordinate System and table Direction and Inertial Resultant of Body Acceleration, and in the International Standards Organization (ISO) 2631-1:1997, Mechanical Vibration and Shock – Evaluation of Human Exposure to Whole Body Vibration – Part 1: General Requirements, Figure 1. "Dynamic phases of flight" refers to periods of acceleration and deceleration including ascent, pad and ascent abort, entry, descent, and landing.

To convert from acceleration of free fall, standard (gn) to meter per second squared (m/s²) multiply by 9.80665 (National Institute of Standards and Technology (NIST) Special Publication (SP) 811, 1995 Edition).

3.2.5.1 Health Limits for Vibration During Dynamic Phases of Flight

[HS3105] The Constellation Architecture shall limit vibration to the crew such that the vectorial sum of the X, Y, and Z frequency-weighted accelerations between 0.5 and 80 Hz is less than or equal to the levels and durations in HS3105, table Frequency-Weighted Vibration Limited by Exposure Time During Dynamic Phases of Flight during dynamic phases of flight.

TABLE 3.2.5.1-1 - FREQUENCY-WEIGHTED VIBRATION LIMITS BY EXPOSURE TIME DURING DYNAMIC PHASES OF FLIGHT

Maximum Vibration Exposure Duration Per 24-hr Period	Maximum Frequency-Weighted Acceleration
10 Minutes	0.4 g rms
1 Minute	0.6 g rms

Rationale: There are limited data on the effects of high levels of vibration on health. It is expected that internal organs and tissue structures could be damaged if the level of vibration or the time period for these levels were increased. Studies were conducted in the 1960s to evaluate human tolerance to higher levels of vibration between 3 and 20 Hz for exposures lasting less than 5 minutes (Temple et al, 1964). These studies were conducted in the controlled laboratory environment with subjects supported by a rigid single-component space couch. A multiple component, non-rigid support may increase the risk of injury to the spinal column. In the semi-supine space couch configuration, the

Revision: E	Document No: CxP 70024
Release Date: 11/19/10	Page: 64 of 503
Title: Constellation Program Human-Systems Integration Requirements	

sustained accelerative forces (i.e., constant G-load bias equal to 1.0 gn) are directed through the X-axis (back to chest) of the occupant. The main focus of complaints was pain or pressure in the thorax and difficulty with respiration. Discomfort was also reported in the abdomen and head. The 0.6-g weighted rms level falls in the vicinity of the upper boundary of the ISO 2631-1:1997, Annex B, Figure B.1 Health Guidance Caution Zones for a 1-minute exposure occurring during a 24-hour period. Above this boundary, health risks are likely. Below this boundary, caution for the potential for health risks is indicated. However, it should be noted that some individuals involved in the studies conducted by Temple et al were unable to withstand vibration at the 0.6-g rms level for frequency components between 10 and 20 Hz because of severe discomfort. The 0.4-g weighted rms level for 10-minute exposure, however, is within the tolerance levels reported by Temple, et al (1964) for the frequencies between 3 and 20 Hz. The 0.4-g weighted rms level falls between the upper and lower boundaries of the ISO Standard 2631-1:1997, Annex B, Figure B.1 Health Guidance Caution Zones, where caution should be taken with regard to the potential for health risk. For reference, the Apollo launch specification for the Command Module couch (Report SID 64-1344C Space Division of North American Rockwell, Figure 18 B), yielded a maximum raw unweighted vibration level of 0.77 g rms when integrated from 0.5 to 80 Hz. This maximum, which occurred ~90 sec following lift-off, lasted less than 10 sec (SID 64-1344C, Figure 9). Application of ISO standard 2631-1:1997 weighting factor W_k and constant $k=1.0$ for the body z-axis, described in the accompanying verification requirement, reduces this level to 0.26 g rms. Application of ISO standard 2631-1:1997 weighting factor W_d and constant $k = 1.4$ for the body x-axis, described in the accompanying verification requirement, reduces this level to 0.07 g rms. This requirement will be met by integrated systems with the details of each system's responsibility in individual system SRDs and in IRDs.

3.2.5.2 Vibration Limits during Crew Sleep

[HS3106] The Constellation Architecture shall limit vibration to the crew such that the frequency-weighted acceleration between 1.0 and 80 Hz in each of the X, Y, and Z axes is less than 0.01 g rms for each 2-minute interval during an 8.5-hour crew sleep period.

Rationale: For long-duration exposure (~8.5 hours), smaller vibrations to which the crew is exposed can adversely affect crew sleep. International Standards Organization (ISO) 6954:2000, Mechanical vibration – Guidelines for the measurement, reporting and evaluation of vibration with regard to habitability on passenger and merchant ships, provides vibration exposure guidelines for habitability onboard passenger and merchant ships to include sleep areas and reflects the occupant perception of the vibration in these areas. ISO-6954:2000, Section 7 states that vibration of 0.01 g rms or lower for crew accommodation areas in ships is not likely to draw adverse comments from occupants. CxP 70007, Constellation Design Reference Missions and Operational Concepts,

Revision: E	Document No: CxP 70024
Release Date: 11/19/10	Page: 65 of 503
Title: Constellation Program Human-Systems Integration Requirements	

Annex 2: Flight Operations Scenarios can be referenced for information concerning duration of crew sleep periods.

3.2.5.3 Pre-Launch Vibration Limit to Prevent Motion Sickness

[HS3108] The Constellation Architecture shall limit vibration to the crew such that the frequency-weighted acceleration between 0.1 to 0.5 Hz in each of the X, Y, and Z axes is less than 0.05 g rms for each 10-minute interval during pre-launch.

Rationale: Low-frequency vibration, especially in the range between 0.1 and 0.5 Hz, has the potential to cause motion sickness over relatively short exposure periods. This may be encountered while the crew is in the vehicle during the pre-launch period, given that the tall vehicle stack may be susceptible to swaying back and forth. Reducing the amount of sway will prevent the onset of motion sickness during the pre-launch phase. For assessing vibration between 0.1 and 0.5 Hz, the Motion Sickness Dose Value (MSDV) is calculated in accordance with ISO 2631-1: 1997, Annex D, Equation D-1. According to ISO2631-1: 1997, Annex D, the percentage of unadapted adults who may vomit is equal to 1.3 MSDV. The value 0.05 g weighted rms acceleration indicates that approximately 17% or 1 out of 6 crewmembers may vomit. Although the ISO 2631-1 limits the acceleration measurement for assessing motion sickness to the vertical direction, this is based on the assumption that the human is in the seated upright posture. Because the occupants of the subject vehicle will be in the semi-supine posture, the requirement is applied to all three orthogonal axes, X, Y, and Z. The purpose of the 10-minute integration time is to constrain the deviations around the permitted average sway during a 2-hour pre-launch period. This requirement will be met by integrated systems with the details of each system's responsibility in individual system SRDs and in IRDs.

3.2.6 Acoustics

The requirements of this section will ensure that the vehicle provides the crew with an acoustic environment that will not cause injury or hearing loss, interfere with voice communications, cause fatigue, or in any other way degrade overall human-machine system effectiveness.

The term "at the crewmember's ear" is used for requirements for which hearing protection is allowed when meeting the requirement, while "at the head" is used for requirements for which hearing protection is not allowed. When simulation is required, the ear canal volume will be assumed to be 2.0 cc.

3.2.6.1 Acoustic Limits for Launch and Entry Phases

3.2.6.1.1 Acoustic Limits for Post-Landing

[HS3134] The system shall limit the Speech Interference Level, SIL (0.5, 1, 2, 4) and A-weighted overall SPL, created by the sum of all simultaneously operating equipment, averaged over any 20 second measurement period, at crewmember head locations, to

Revision: E	Document No: CxP 70024
Release Date: 11/19/10	Page: 66 of 503
Title: Constellation Program Human-Systems Integration Requirements	

61 dB and 75 dBA or less, respectively, during post-landing operations, including off-nominal contingency operations.

Rationale: To control the interfering effects of high noise levels on crew voice communications subsequent to landing, including planned off-nominal operations, e.g. Snorkel Fan. SIL (0.5, 1, 2, 4) or SIL(4) is calculated by one-fourth of the sum of the octave band sound pressure levels, in dB, for octave bands with center frequencies of 500, 1000, 2000, and 4000 Hz. This requirement is based on ANSI S12 65-2006 for the crewmember head-to-head distance of 1.7 m (5.5 ft). The SIL limit was set at the voice level of "Very Loud" in Figure 1 of ANSI S12 65-2006. The effect of reduced female voice intensity was also included by reducing the SIL level in Figure 1 by 4 dB (Reference Beranek and Ver, Noise and Vibration Control Engineering, 1992). The A-weighted Overall Sound Pressure Level component of this requirement has been added to control the frequency range outside of the SIL range and is not intended to protect voice communications; it protects crew-hearing.

3.2.6.1.2 Noise Dose Limits for Launch and Entry

[HS3073] The Constellation Architecture shall limit the noise dose at the crewmember's ear calculated over any 24-hour period, to 100% or less, where the 24-hour noise dose, D, is calculated by:

$$D = 100 \sum_{n=1}^N \frac{C_n}{T_n}$$

where N is the number of noise exposure events during the 24-hour period, C_n is the actual duration of the exposure event in minutes, and T_n is the maximum noise exposure duration allowed, based on the specific noise level, L_n, of an exposure event in dBA, calculated using:

$$T_n = \frac{480}{2^{(L_n - 85)/3}}$$

during launch and entry phases including ascent abort.

Rationale: Equivalent noise exposure levels above 85 dBA for more than 8 hours have been shown to increase the risk of noise-induced hearing loss. The above formulae can be used to calculate the 24-hour noise exposure levels based on the 8-hour 85 dBA criterion recommended by the National Institute for Occupational Safety and Health (NIOSH), using the 3 dB trading rule. The noise attenuation effectiveness of hearing protection or communications headsets may be used to satisfy this requirement. This limit does not apply to impulse noise. This requirement will be met by integrated systems with the details of each system's responsibility in individual system SRDs and in IRDs.

Revision: E	Document No: CxP 70024
Release Date: 11/19/10	Page: 67 of 503
Title: Constellation Program Human-Systems Integration Requirements	

3.2.6.1.3 Impulse Noise Limit for Launch and Entry

[HS3074] The Constellation Architecture shall limit impulse noise at the crewmember's ear to less than 140 dB peak overall Sound Pressure Level (SPL) during launch and entry including ascent abort.

Rationale: A limit of 140 dB peak SPL for impulse noise will prevent trauma to the hearing organs caused by impulse noise. Ref.: MIL-STD-1474D, Department of Defense Design Criteria Standard-Noise Limits. The noise attenuation effectiveness of hearing protection or communications headsets may be used to satisfy this requirement. This requirement will be met by integrated systems with the details of each system's responsibility in individual system SRDs and in IRDs.

3.2.6.1.4 Hazardous Noise Limit for Launch and Entry

[HS3072] The Constellation Architecture shall limit the maximum A-weighted overall SPL at the crewmember's ear to 105 dBA or less during launch, entry, and suited (helmet on, visor down) burn-phases, and to 115 dBA or less during launch abort.

Rationale: Noise levels above 115 dBA have been shown to produce noise-induced hearing loss, and the 105 dBA limit allows headroom for alarms and voice communications. During launch abort, the communications during the abort motor firing are not needed, so the 115 dBA requirement is appropriate. Launch abort includes all aborts that may occur during take-off including pad, ascent, and high-altitude aborts. The noise attenuation effectiveness of hearing protection or communications headsets may be used to satisfy this requirement. This limit does not apply to impulse noise. This requirement will be met by integrated systems with the details of each system's responsibility in individual system SRDs and in IRDs.

3.2.6.1.5 Infrasonic Noise Limits

[HS3081] The system shall limit infrasonic overall SPL at the crewmember's head location for frequencies from 1 to 20 Hz to less than 150 dB.

Rationale: The 150-dB limit for infrasonic noise levels in the frequency range from 1 to 20 Hz provides for health and well-being effects. The noise attenuation effectiveness of hearing protection or communications headsets may not be used to satisfy this requirement, Ref.: 2001 American Conference of Governmental Industrial Hygienists, Threshold Level Values (TLVs), "Infrasound and Low-Frequency Sound." This limit does not apply to impulse noise. No equivalent Ultrasonic requirement is necessary as counterpoint to this infrasonic requirement.

Revision: E	Document No: CxP 70024
Release Date: 11/19/10	Page: 68 of 503
Title: Constellation Program Human-Systems Integration Requirements	

3.2.6.2 Acoustic Limits for the Orbit Phase

3.2.6.2.1 Sound Pressure Level (SPL) Limits for Waste Management System

[HS3133] The system shall limit the intermittent A-weighted overall SPL environment, measured at the expected user's head position of crew-waste management systems, and at crew station head positions in the main habitable volume, to 68 dBA or less while the toilet is in operation.

Rationale: To provide for adequate hearing protection for toilet users of the WMS and crews at work stations in the main habitable volume. The above level poses minimum impact to communication interference. This requirement is based on a nominal toilet usage of 1 hour or less by individual crew, and 3 hours or less by others, over any 24-hour period and was based on ISS requirements, SSP 57000, Pressurized Payload Interface Requirements Document for Operations Within a Rack. The noise attenuation effectiveness of hearing protection or communications headsets may not be used to satisfy this requirement.

3.2.6.2.2 Impulse Noise Limit for the Orbit Phase

[HS3078] The system shall limit impulse noise, measured at the crewmember's head location to less than 120 dB peak SPL during all mission phases except launch and entry.

Rationale: A limit of 140 dB peak SPL for impulse noise will prevent acoustic trauma. Ref.: MIL-STD-1474D. A limit of 120 dB peak SPL for impulse noise will prevent the crewmembers from being startled. The noise attenuation effectiveness of hearing protection or communications headsets may not be used to satisfy this requirement.

3.2.6.2.3 Annoyance Noise Limits for Crew Sleep

[HS3079] The system shall limit impulse and intermittent noise SPLs at the crewmember's head location to less than 83 dB peak and 70 dBA, respectively, during crew sleep periods.

Rationale: Impulse noise must be limited to less than 10 dB above the background noise to avoid waking crewmembers who are sleeping. Ref.: NASA-STD-3000, Man-Systems Integration Standards, Volume 1, Section 5.4.3.2.3.4. Communications and alarms are not subject to this requirement.

3.2.6.2.4 Hazardous Noise Limit for the Orbit Phase

[HS3075] The system shall limit the maximum A-weighted overall SPL at the crewmember's head location and at the ears of space-suit occupants caused by known noise sources, including voice communications and alarms, and certified off-nominal operations to less than 85 dBA, during all mission phases except launch and entry.

Revision: E	Document No: CxP 70024
Release Date: 11/19/10	Page: 69 of 503
Title: Constellation Program Human-Systems Integration Requirements	

Rationale: The 85 dBA overall sound pressure level defines the hazardous noise limit at which action to reduce the noise level must be taken so that interference with voice communications and alarms, as well as increased risk for hearing loss, does not occur. This requirement is not intended for nominal hardware emissions, whose requirements are specified in HS3076 and HS3109 but to limit the sound level of sources such as alarms, communications systems, and levels that occur during maintenance activities and certified off-nominal operations. This requirement was taken from NASA-STD-3000, Figure 5.4.3.2.1.1. The noise attenuation effectiveness of hearing protection or communications headsets may not be used to satisfy this requirement, except for when this requirement is being applied to noise inside the space suit. Note that alarm and voice communication levels inside the space suit are controlled by HS3110. This limit does not apply to impulse noise.

3.2.6.2.5 Sound Pressure Level (SPL) Limits for Continuous Noise during the Orbit Phase

[HS3076] The system shall limit the SPLs, created by the sum of all simultaneously operating equipment, averaged over any 20-second measurement period, throughout the crew habitable volume, and at the ears of the space-suit occupant, to the values in HS3076, table Octave Band Sound Pressure Level Limits or less, within each of the specified octave bands during all mission phases except launch and entry.

TABLE 3.2.6.2.5-1 - OCTAVE BAND SOUND PRESSURE LEVEL LIMITS

Band center frequency (Hz)	63	125	250	500	1 k	2 k	4 k	8 k	16 k
SPL (dB)	72	65	60	56	53	51	50	49	48

Rationale: This NC-52 requirement will limit noise levels within the crew-habitable volume and in space suits (with visors up and down) to allow for adequate voice communications and habitability during the on-orbit mission operations. The octave band sound level limits from 63 Hz to 8 kHz are equivalent to NC-52 and the 16-kHz octave band has been added to extend the range throughout the audible frequency range. This requirement does not apply to alarms, communications, items listed in HS3109, table Approved Intermittent Noise Sources, or to any noise experienced during maintenance activities. The noise attenuation effectiveness of hearing protection or communications headsets may not be used to satisfy this requirement, except for when this requirement is being applied to noise inside space suits when the helmet and communication headsets are being worn. This limit does not apply to impulse noise.

Revision: E	Document No: CxP 70024
Release Date: 11/19/10	Page: 70 of 503
Title: Constellation Program Human-Systems Integration Requirements	

3.2.6.2.6 Sound Pressure Level (SPL) Limits for Intermittent Noise during the Orbit Phase

[HS3109] The system shall limit intermittent A-weighted overall SPL emissions from sources listed in HS3109, table Approved Intermittent Noise Sources, measured 0.6 m from the loudest point on the hardware, to the levels and nominal durations in HS3109, table Intermittent Noise A-Weighted Overall Sound Pressure Level and Corresponding Durational Duration Limits (Measured at 0.6 M) or less, for the time noise exceeds limits in HS3076, table Octave Band Sound Pressure Level Limits, over any 24-hour period during all mission phases except launch and entry.

TABLE 3.2.6.2.6-1 - APPROVED INTERMITTENT NOISE SOURCES

Pressurized Gas Transfer Systems
Portable Equipment, Payloads and Cargo
Engines/Thrusters
Motorized valve assemblies
Carbon Dioxide and Humidity Control Systems (including Swing Bed Pressure Exchange Systems)

Revision: E	Document No: CxP 70024
Release Date: 11/19/10	Page: 71 of 503
Title: Constellation Program Human-Systems Integration Requirements	

TABLE 3.2.6.2.6-2 - INTERMITTENT NOISE A-WEIGHTED OVERALL SOUND PRESSURE LEVEL AND CORRESPONDING OPERATIONAL DURATION LIMITS (MEASURED AT 0.6 M)

Maximum Noise Duration Per 24-hour Period	LA_{max} (dBA re 20 µPa)
8 Hours	≤ 49
7 Hours	≤ 50
6 Hours	≤ 51
5 Hours	≤ 52
4.5 Hours	≤ 53
4 Hours	≤ 54
3.5 Hours	≤ 55
3 Hours	≤ 57
2.5 Hours	≤ 58
2 Hours	≤ 60
1.5 Hours	≤ 62
1 Hour	≤ 65
30 Minutes	≤ 69
15 Minutes	≤ 72
5 Minutes	≤ 76
2 Minutes	≤ 78
1 Minute	≤ 79
Not Allowed	≥ 80

Rationale: This requirement is a relaxation of the continuous noise requirement HS3076 for specifically approved intermittent noise producing hardware, and still provides for adequate speech intelligibility and habitability. Intermittent noise producing hardware not included in the table above must meet HS3076. Levels in HS3109, table Intermittent Noise A-Weighted Overall Sound Pressure Level and Corresponding Durational Duration Limits (Measured at 0.6 M) will limit intermittent noise levels of specific hardware items that are inherently noisy and operate for a short time period where alternative means for noise control are prohibitively expensive or impractical. Durations associated with contingencies need not be used to define the noise level. The nominal duration will be used to determine the appropriate noise level. These sound level and operational duration limits are taken from ISS requirements (SSP 57000, Pressurized Payload Interface Requirements Document). The noise attenuation effectiveness of hearing protection or communications headsets may not be used

Revision: E	Document No: CxP 70024
Release Date: 11/19/10	Page: 72 of 503
Title: Constellation Program Human-Systems Integration Requirements	

to satisfy this requirement. This limit does not apply to impulse noise. Note that intermittent noise during crew sleep is limited to 70 dBA according to [HS3079] Annoyance Noise Limit for Crew Sleep.

3.2.6.2.7 Tonal and Narrow-Band Noise Limits

[HS3080] The system shall limit the maximum SPL of narrow-band noise components and tones to at least 10 dB less than the broadband SPL of the octave band that contains the component or tone for the 1-, 2-, 4-, and 8-kHz octave bands, and at least 5 dB less than the broadband SPL of the octave band that contains the component or tone for the 63-, 125-, 250-, and 500-Hz octave bands.

Rationale: Limiting narrow band noise component and tone levels to 10 dB below the broadband level will prevent irritating and distracting acoustic conditions. Ref.: NASA-STD-3000, Figure 5.4.3.2.3.2.

3.2.6.3 All Flight Phases

3.2.6.3.1 Cabin Depressurization Valve Hazardous Noise Limit

[HS3082] The system shall limit the maximum A-weighted overall SPL, at the crewmember's ear, to 105 dBA or less during cabin depressurization valve operations.

Rationale: Noise levels above 115 dBA have been shown to produce noise-induced hearing loss, and the 105-dBA limit allows headroom for alarms and voice communications. Historically, cabin depressurization valves have produced a high level of noise. Whether or not the use of hearing protection may be used to satisfy this requirement will be specified in the Level III documentation. This limit does not apply to impulse noise.

3.2.6.3.2 Cabin Depressurization Valve Noise Dose Limits

[HS3083] The system shall limit the noise dose at the crewmember's ear, calculated over any 24-hour period, to 100% or less, where the 24-hour noise dose, D , is calculated by:

$$D = 100 \sum_{n=1}^N \frac{C_n}{T_n}$$

where N is the number of noise exposure events during the 24-hour period, C_n is the actual duration of the exposure event, and T_n is the maximum noise exposure duration allowed, based on the specific noise level, L_n , of an exposure event, calculated using:

$$T_n = \frac{480}{2^{(L_n - 85)/3}}$$

during cabin depressurization valve operations.

Rationale: Equivalent noise exposure levels above 85 dBA for more than 8 hours have been shown to increase the risk of noise-induced hearing loss. The

Revision: E	Document No: CxP 70024
Release Date: 11/19/10	Page: 73 of 503
Title: Constellation Program Human-Systems Integration Requirements	

above formulae can be used to calculate the 24-hour noise exposure levels based on the 8-hour 85-dBA criterion recommended by NIOSH, using the 3-dB trading rule. This limit does not apply to impulse noise. Whether or not the use of hearing protection may be used to satisfy this requirement will be specified in the Level III documentation.

3.2.6.3.3 Reverberation Time

[HS3084] The system shall provide a reverberation time in the crew habitable volume of less than 0.6 second within the 500-Hz, 1-kHz, and 2-kHz octave bands.

Rationale: This 0.6-second reverberation time standard will limit degradation of speech intelligibility to no more than 10% for ideal signal-noise ratios of >30 dB or 15% for a signal-noise ratio of 3 dB. Reference NASA-STD-3000, Figure 5.4.3.2.2.1, and C. M. Harris, "Handbook of Acoustical Measurements and Noise Control, 3rd Ed.," p. 16.8.

3.2.6.3.4 Noise Limit for Personal Communication Devices

[HS3110] The system shall limit the maximum SPL at the crewmember's ear created by a personal communication device to 115 dBA or less.

Rationale: Noise levels above 115 dBA have been shown to produce noise-induced hearing loss. Sound levels produced by personal communication devices are allowed to be at higher levels to overcome the noise generated during launch and descent. A personal communication device may be an integrated part of the EVA helmet or an independent communication headset.

3.2.6.3.5 Loudspeaker Alarm Audibility

[HS3111] Loudspeakers shall produce non-speech auditory annunciations that exceed the masked threshold by at least 13 dB in one or more one-third octave bands where the alarm resides, as measured at the crewmember's expected work and sleep station head locations.

Rationale: The 13-dB signal-to-noise ratio ensures that non-speech auditory annunciations are sufficiently salient and intelligible, according to ISO 7731, Ergonomics - Danger signals for public work areas Auditory danger signals. ISO 7731 is an accepted standard for ensuring the ability to detect and discriminate non-speech alarms and alerts.

3.2.7 Ionizing Radiation

The radiation sources in space, Galactic Cosmic Radiation (GCR), trapped particle radiation, and Solar Particle Events (SPEs), have distinct physical and biological damage properties compared to terrestrial radiation, and thus require distinct methods to project and mitigate risks. NASA uses gender-based risk models and is developing new approaches to risk estimation.

Revision: E	Document No: CxP 70024
Release Date: 11/19/10	Page: 74 of 503
Title: Constellation Program Human-Systems Integration Requirements	

Astronauts have been classified as radiation workers, and processes exist to protect them from excessive radiation exposure. Therefore, exposures must be kept As Low As Reasonably Achievable (ALARA).

3.2.7.1 Radiation Design Requirements

3.2.7.1.1 Radiation Design Requirements

[HS3085] The system shall provide protection from radiation exposure consistent with ALARA principles to ensure that effective dose (tissue averaged) to any crewmember does not exceed the relevant value given in HS3085, table System-Specific Radiation Design Requirements, for the design SPE, as specified in CxP 70023, Constellation Program Design Specification for Natural Environments (DSNE), Section 3.3.4.

TABLE 3.2.7.1.1-1 - SYSTEM-SPECIFIC RADIATION DESIGN REQUIREMENTS

System	Radiation Design Requirement (mSv)
Orion	150
Altair	150

Rationale: The radiation design requirement is imposed to prevent clinically significant deterministic health effects, including performance degradation, sickness, or death in flight and to ensure that crew career exposure limits are not exceeded with 95% confidence. The ALARA principle is a legal requirement intended to ensure astronaut safety. An important function of ALARA is to ensure that astronauts do not approach radiation limits and that such limits are not considered "tolerance values." ALARA is an iterative process of integrating radiation protection into the design process, ensuring optimization of the design to afford the most protection possible, within other constraints of the vehicle systems. The protection from radiation exposure is ALARA when the expenditure of further resources would be unwarranted by the reduction in exposure that would be achieved. Radiation protection for humans in space differs from that on Earth because of the distinct types of radiation, the small population of workers, and the remote location of astronauts during spaceflight. The radiation sources in space, Galactic Cosmic Rays (GCRs), trapped particle radiation, and Solar Particle Events (SPEs), have distinct physical and biological damage properties compared to terrestrial radiation, and the spectrum and energy of concern for humans differs from that for electronics. Radiation protection for the crew must consider this environment and these concerns. This requirement does not address GCR and trapped radiation exposure during the mission. Exposure to nominal mission exposure will be covered by a legal exposure limit.

Revision: E	Document No: CxP 70024
Release Date: 11/19/10	Page: 75 of 503
Title: Constellation Program Human-Systems Integration Requirements	

3.2.7.2 Active Radiation Monitoring

3.2.7.2.1 Charged Particle Monitoring

[HS3086] The system shall continuously measure and record the external fluence of particles of $Z < 3$, in the energy range 30 to 300 MeV/nucleon and particles of $3 \leq Z \leq 26$, in the energy range 100 to 400 MeV/nucleon and integral fluence measurement at higher energies, as a function of energy and time, from a monitoring location that ensures an unobstructed free space full-angle field-of-view 1.1345 radians (65 degrees) or greater.

Rationale: The data from the charged particle monitoring are the fundamental environmental information required for radiation transport calculations and crew exposure evaluation. Given an accurately measured proton energy spectra incident on the vehicle during a solar particle event, detailed crew exposure can be evaluated. This will limit the uncertainty of a single absorbed dose measurement in determining crew exposure from a solar particle event. The external fluence of particles of $Z < 3$, in the energy range 30 to 300 MeV/nucleon and particles of $3 \leq Z \leq 26$, in the energy range 100 to 400 MeV/nucleon, contains a large portion of the radiation environment expected for solar particle events, trapped particle radiation, and galactic cosmic rays. The chosen range is appropriate for the practical size and weight of radiation monitors suitable for the vehicle. The minimum angle required to establish a geometry factory needed to accurately measure the radiation fields is 1.1345 radians (65 degrees). Charged particle monitoring hardware should be portable and transition with the crew in the primary vehicle during the mission to lunar surface and return to Low Earth Orbit (LEO).

3.2.7.2.2 Dose Equivalent Monitoring

[HS3088] The system shall provide an omnidirectional, portable system that can continuously measure and record the dose equivalent from charged particles with Linear Energy Transfer (LET) 0.2 to 1,000 keV/micrometer, as a function of time, at an average tissue depth of at least 2 mm.

Rationale: This measurement is the primary means for controlling crew exposure during missions. The current exposure limit quantity for stochastic effects (career exposure limits) is specified in dose equivalent. Tissue equivalent microdosimeters have been used extensively for crew exposure monitoring in space for this purpose. There is a large set of data and calculations in the published literature that can be directly applied to crew exposure and risk determination using tissue equivalent microdosimeters. The range of Linear Energy Transfer of 0.2 to 1,000 keV/ μm includes the full range expected from primary and secondary radiations of Solar Particle Events, trapped particle radiation, and galactic cosmic rays. It is expected that this requirement and the absorbed dose monitoring requirement (HS3089) will be met by the same instrument. Absorbed dose monitoring hardware and dose equivalent monitoring

Revision: E	Document No: CxP 70024
Release Date: 11/19/10	Page: 76 of 503
Title: Constellation Program Human-Systems Integration Requirements	

hardware should be portable and be able to transition with the crew in the primary vehicle during the mission to lunar surface and return to LEO.

3.2.7.2.3 Absorbed Dose Monitoring

[HS3089] The system shall provide an omnidirectional, portable system that can continuously measure and record the absorbed dose from charged particles with Linear Energy Transfer 0.2 to 1,000 keV/micrometer, as a function of time, at an average tissue depth of at least 2 mm.

Rationale: The absorbed dose/dose equivalent instrument will be the primary instrument for controlling crew exposure during missions. The current exposure limit quantity for deterministic effects (short term exposure limits) requires the determination of absorbed dose. Tissue equivalent micro dosimeters have been used extensively for crew exposure monitoring in space. There is a large set of data and calculations in the published literature that can be directly applied to crew exposure and risk determination, using tissue equivalent micro dosimeters. The range of Linear Energy Transfer of 0.2 to 1,000 keV/micrometer includes the full range expected from primary and secondary radiations of Solar Particle Events and galactic cosmic rays. It is expected that this requirement and the dose equivalent monitoring requirement (HS3088) will be met by the same instrument. Absorbed dose monitoring hardware should be portable and be able to transition with the crew in the primary vehicle during the mission to Lunar surface and return to LEO.

3.2.7.3 Passive Radiation Monitoring

3.2.7.3.1 Passive Radiation Monitoring

[HS3090] The system shall provide passive dosimetry, capable of measuring time integrated absorbed dose and estimating Linear Energy Transfer based quality factors, at a minimum of six designated fixed locations within each pressurized vehicle/element.

Rationale: Passive area monitors provide a time-integrated measure of the spatial distribution of exposure rates inside the Constellation vehicles/elements. The exposure rates change with stowage reconfigurations. Knowledge of the spatial distribution of exposure rate is necessary to identify areas that have a relatively high exposure rate (i.e., avoidance areas) and to reconstruct a crewmember's exposure in the event of lost or unusable personal dosimeter data. Passive dosimeters collect data even during situations when power is lost to other instruments.

3.2.7.4 Reporting Radiation Data

3.2.7.4.1 Radiation Data Reporting to the Crew - Absorbed Dose

[HS3091] The system shall display the measured cumulative absorbed dose/minute averaged dose rate to the crew once per minute, with latency less than five minutes.

Revision: E	Document No: CxP 70024
Release Date: 11/19/10	Page: 77 of 503
Title: Constellation Program Human-Systems Integration Requirements	

Rationale: Radiation data are vital for quantifying in-flight risks to the crew. For periods of time when the crew is not in communication with Mission Operations, the crew will need to be able to ascertain the radiation conditions within the vehicle and take appropriate actions as required. The changes in the radiation environment that could cause additional crew exposure can occur in time periods as small as 1 to 5 minutes.

3.2.7.4.2 Radiation Data Reporting to the Crew - Dose Equivalent

[HS3119] The system shall display the measured cumulative dose equivalent/minute averaged dose equivalent rate to the crew once per minute, with latency less than 5 minutes.

Rationale: Radiation data are vital for quantifying in-flight risks to the crew. For periods of time when the crew is not in communication with Mission Operations, the crew will need to be able to ascertain the radiation conditions within the vehicle and take appropriate actions as required. The changes in the radiation environment that could cause additional crew exposure can occur in time periods as small as 1 minute to 5 minutes.

3.2.7.4.3 Radiation Data Reporting to Mission Systems - Absorbed Dose

[HS3112] The system shall provide the measured cumulative absorbed dose/minute averaged dose rate to Mission Systems once per minute during periods when communication is available, with latency less than 5 minutes.

Rationale: Radiation data are vital for quantifying in-flight risks to the crew and for allowing Mission Operations to advise the crew on appropriate action in response to an SPE. The quiescent galactic cosmic ray and trapped radiation data will be used to track the crew exposure throughout the mission as well as provide positive indication of proper health and status of the absorbed dose instrument. This will ensure instrument performance before the onset of any solar particle event that may occur.

3.2.7.4.4 Radiation Data Reporting to Mission Systems - Dose Equivalent

[HS3120] The system shall provide the measured cumulative dose equivalent/minute averaged dose equivalent rate to Mission Systems once per minute during periods when communication is available, with latency less than 5 minutes.

Rationale: Radiation data are vital for quantifying in-flight risks to the crew and for allowing Mission Operations to advise the crew on appropriate action in response to an SPE. The quiescent galactic cosmic ray and trapped radiation data will be used to track the crew exposure throughout the mission as well as provide positive indication of proper health and status of the absorbed dose instrument. This will ensure instrument performance before the onset of any solar particle event that may occur.

Revision: E	Document No: CxP 70024
Release Date: 11/19/10	Page: 78 of 503
Title: Constellation Program Human-Systems Integration Requirements	

3.2.7.4.5 Particle Archive Data

[HS3113] The system shall provide the archive of all recorded charged particle, dose equivalent, and absorbed dose data to Mission Systems by the completion of the mission.

Rationale: Charged particle, dose equivalent, and absorbed dose data taken during missions will be used post-mission for radiation dose/risk assessment. These data will be used to determine the final dose of record for crewmembers, which will be used to track against crew exposure limits.

3.2.7.5 Alerting for Radiation Data

3.2.7.5.1 Alerting for Radiation Data

[HS3092] The system shall alert the crew whenever the absorbed dose rate exceeds a pre-flight programmable threshold in the range 0.02 mGy/min to 10 mGy/min for three consecutive readings.

Rationale: Should communications from the ground be interrupted or lost, the crew requires on-board warnings when the radiation environment crosses dangerous thresholds so appropriate countermeasure actions can be taken. Varying user-defined thresholds may be set according to the radiation environmental conditions that may be encountered depending on mission phase. The intent is for the vehicle data management system to provide the alerting functionality.

3.2.8 Non-Ionizing Radiation (NIR)

3.2.8.1 Radio-Frequency Electromagnetic (EM) Field Radiation Limits

3.2.8.1.1 Radio-Frequency Electromagnetic Field Radiation Limits

[HS3093] The system shall limit the crew's exposure to radio-frequency (RF) electromagnetic fields to the limits specified in Appendix C, table Maximum Permissible Exposure (MPE) to Radio Frequency Electromagnetic Fields (Modified from IEEE C95.1-2005, Lower Tier) and figure Radio Frequency Electromagnetic Field Exposure Limits (Illustrated to Show Whole Body Resonance Effects Around 100 MHz) (Modified from IEEE C95.1-2005).

Rationale: All devices that generate radio frequency radiation (including, but not limited to, antennas and wireless systems) must limit the amount of this radiation to which the crew can be exposed. These limits are modified from the Institute of Electrical and Electronic Engineers (IEEE) C95.1-2005, "Standard Levels with Respect to Human Exposure to Radio Frequency Electromagnetic Fields, 3 kHz to 300 GHz." They are intended to establish exposure conditions for radio-frequency and microwave radiation to which it is believed that nearly all workers can be repeatedly exposed without injury. Modifications were made to the C95.1-2005 standard to remove an excessive safety margin in the power density

Revision: E	Document No: CxP 70024
Release Date: 11/19/10	Page: 79 of 503
Title: Constellation Program Human-Systems Integration Requirements	

limit that was added in the 2005 standard. This margin was added to account for theoretical possibility that small children could exceed the whole body averaged specific absorption rate basic restriction of 0.08 W/kg. This requirement maintains a minimal safety factor of 50 for adults.

3.2.8.2 Laser Radiation Limits

3.2.8.2.1 Ocular Exposure to Lasers

[HS3094] The system shall maintain ocular exposure of the crew to laser systems below the limits specified in ANSI Z136.1, 2007, American National Standard for Safe Use of Lasers, Table 5a and Table 5b without protective equipment

Rationale: This requirement limits ocular exposure to both continuous and repetitively pulsed lasers to protect against eye injury. The limits are adopted from the Laser Institute of America's publication "American National Standard for Safe Use of Lasers" (ANSI Z136.1, 2007). The term laser system includes the laser, its housing, and controls. This requirement applies to laser systems utilized both internal and external to the vehicle. The safety analysis of all lasers will be carried out by ANSI Z136.1 methodology as specified in the verification requirement.

3.2.8.2.2 Dermal Exposure to Lasers

[HS3096] The system shall maintain dermal exposure of the crew to laser systems below the limits specified in ANSI Z136.1, 2007, American National Standard for Safe Use of Lasers, Table 7 without protective equipment.

Rationale: This requirement limits dermal exposure to both continuous and repetitively pulsed lasers to protect against skin injury. The limits are adopted from the Laser Institute of America's publication ANSI Z136.1, 2007, American National Standard for Safe Use of Lasers. The term laser system includes the laser, its housing, and controls. This requirement applies to laser systems utilized both internal and external to the vehicle. The safety analysis of all lasers will be carried out by ANSI Z136.1 methodology as specified in the verification requirement.

3.2.8.3 Incoherent Radiation Limits

Requirements for limiting crew exposure to the electromagnetic spectrum from the ultraviolet (180 nm) to the far infrared (3,000 nm) are derived from the methodology given in the American Conference of Governmental Industrial Hygienists (ACGIH) standard, Threshold Limit Values® and Biological Exposure Indices®, sections "Light and Near-Infrared Radiation" and "Ultraviolet Radiation."

This methodology allows for the quantification of the relationship between source strength and acceptable exposure times for each of four potential injury pathways (retinal thermal injury caused by exposure to visible light, retinal photochemical injury caused by chronic exposure to blue-light, thermal injury to the ocular lens and cornea

Revision: E	Document No: CxP 70024
Release Date: 11/19/10	Page: 80 of 503
Title: Constellation Program Human-Systems Integration Requirements	

caused by infrared exposure, and exposure of the unprotected skin or eye to ultraviolet radiation). These limits do not apply to laser exposure (see laser exposure limits). The numerical values used by the ACGIH are amended for use by NASA by the insertion of a factor of 0.2 in the source term of each calculation with the exception of the calculation for ultraviolet exposure, which is not amended. This removes the excessive margin of safety imposed by the ACGIH on general populations.

3.2.8.3.1 Retinal Thermal Injury from Visible and Near Infrared Sources

3.2.8.3.1.1 Retinal Thermal Injury from Visible and Near Infrared Sources

[HS3098] The system shall limit exposure of the crew to spectral radiance $L\lambda$ at wavelengths between 385 and 1,400 nm such that:

$$0.2 \sum_{385}^{1400} \{L_{\lambda} R(\lambda) \Delta\lambda\} \leq \frac{5}{\alpha t^{1/4}}$$

where $L\lambda$ is the source spectral radiance in $W/(cm^2 \cdot sr \cdot nm)$, $R(\lambda)$ is the Retinal Thermal Hazard Function given in Appendix C, table Blue-Light and Retinal Thermal Hazard Functions, t is the viewing duration in seconds, and α is the angular subtense of the source in radians.

Rationale: This requirement is intended to prevent retinal thermal injury from visible and near-infrared sources with wavelengths between 385 and 1,400 nm. Any exposure to NIR must consider the entire pathway of the incident radiation prior to its interaction with a crewmember's body, including any concentration, diffusion, or filtering. For example, concentration of source radiation by optical instruments and attenuation by vehicle window systems or EVA visors needs to be considered when evaluating the final radiation incident upon the crewmember. Protection from NIR may be accomplished through the reduction of effective irradiance or by limiting exposure times. Any means of providing NIR protection must not permanently degrade the ability of any optical systems to perform their intended function. The transmittance required for windows, visors, and other optical devices can be reconciled with protection from NIR through the use of temporary filters, proper material selection, apertures, beam stops or splitters, or other appropriate means.

3.2.8.3.2 Retinal Photochemical Injury from Visible Light

3.2.8.3.2.1 Small Source Visible Radiation Limits

[HS3099] The system shall limit the spectral irradiance $E\lambda$ of the crew at wavelengths between 305 and 700 nm for visible-light sources subtending an angle less than 11 milliradians, such that:

Revision: E	Document No: CxP 70024
Release Date: 11/19/10	Page: 81 of 503
Title: Constellation Program Human-Systems Integration Requirements	

$$0.2 \sum_{305}^{700} \{E_{\lambda} B(\lambda) \Delta \lambda\} \leq 10 \text{ mJ/cm}^2 \text{ for } t < 10^4 \text{ s}$$

or

$$0.2 \sum_{305}^{700} \{E_{\lambda} B(\lambda) \Delta \lambda\} \leq 1 \text{ } \mu\text{W/cm}^2 \text{ for } t > 10^4 \text{ s}$$

where $B(\lambda)$ is the blue-light hazard function given in Appendix C, table Blue-Light and Retinal Thermal Hazard Functions.

Rationale: This requirement is intended to prevent retinal photochemical injury from exposure to visible-light sources with wavelengths between 305 and 700 nm. Any exposure to NIR must consider the entire pathway of the incident radiation prior to its interaction with a crewmember's body, including any concentration, diffusion, or filtering. For example, concentration of source radiation by optical instruments and attenuation by vehicle window systems or EVA visors need to be considered when evaluating the final radiation incident upon the crewmember. Protection from NIR may be accomplished through the reduction of effective irradiance or by limiting exposure times. Any means of providing NIR protection must not permanently degrade the ability of any optical systems to perform their intended function. The transmittance required for windows, visors, and other optical devices can be reconciled with protection from NIR through the use of temporary filters, proper material selection, apertures, beam stops or splitters, or other appropriate means. The sun subtends an angle of approximately 9 milliradians when observed from earth and is therefore considered a small source.

3.2.8.3.2.2 Large Source Visible Radiation Limits

[HS3101] The system shall limit the exposure of the crew to spectral radiance L_{λ} at wavelengths between 305 and 700 nm for visible light sources subtending an angle greater than or equal to 11 milliradians, such that:

$$0.2 \sum_{305}^{700} \{L_{\lambda} B(\lambda) \Delta \lambda\} \leq 100 \text{ J/(cm}^2 \cdot \text{sr)} \text{ for } t \leq 10^4 \text{ s}$$

or

$$0.2 \sum_{305}^{700} \{L_{\lambda} B(\lambda) \Delta \lambda\} \leq 10^{-2} \text{ W/(cm}^2 \cdot \text{sr)} \text{ for } t > 10^4 \text{ s}$$

where $B(\lambda)$ is the blue-light hazard function given in Appendix C Table C3-6.

Rationale: This requirement is intended to prevent retinal photochemical injury from exposure to large visible-light sources with wavelengths between 305 and 700 nm. Any exposure to NIR must consider the entire pathway of the incident radiation prior to its interaction with a crewmember's body, including any concentration, diffusion, or filtering. For example, concentration of source radiation by optical instruments and attenuation by vehicle window systems or

Revision: E	Document No: CxP 70024
Release Date: 11/19/10	Page: 82 of 503
Title: Constellation Program Human-Systems Integration Requirements	

EVA visors need to be considered when evaluating the final radiation incident upon the crewmember. Protection from NIR may be accomplished through the reduction of effective irradiance or by limiting exposure times. Any means of providing NIR protection must not permanently degrade the ability of any optical systems to perform their intended function. The transmittance required for windows, visors, and other optical devices can be reconciled with protection from NIR through the use of temporary filters, proper material selection, apertures, beam stops or splitters, or other appropriate means.

3.2.8.3.3 Thermal Injury from Infrared Radiation

3.2.8.3.3.1 Thermal Injury from Infrared Radiation

[HS3103] The system shall limit the spectral irradiance E_λ of the crew at wavelengths between 770 and 3,000 nm to 10 mW/cm^2 for exposure durations longer than 1,000 seconds, and for exposure durations less than 1,000 seconds such that:

$$0.2 \sum_{770}^{3000} \{E_\lambda \Delta\lambda\} \leq 1.8 t^{-3/4} \text{ W/cm}^2$$

Rationale: This requirement is intended to prevent ocular injury caused by overexposure to infrared radiation, including delayed effects to the lens (such as cataractogenesis.) These Threshold Limit Values (TLVs) apply to an environment with an ambient temperature of 37 °C, and can be increased by 0.8 mW/cm² for every whole degree below 37 °C. Any exposure to NIR must consider the entire pathway of the incident radiation prior to its interaction with a crewmember's body, including any concentration, diffusion, or filtering. For example, concentration of source radiation by optical instruments and attenuation by vehicle window systems or EVA visors need to be considered when evaluating the final radiation incident upon the crewmember. Protection from NIR may be accomplished through the reduction of effective irradiance or by limiting exposure times. Any means of providing NIR protection must not permanently degrade the ability of any optical systems to perform their intended function. The transmittance required for windows, visors, and other optical devices can be reconciled with protection from NIR through the use of temporary filters, proper material selection, apertures, beam stops or splitters, or other appropriate means.

3.2.8.3.4 Ultraviolet Exposure for Unprotected Eye or Skin

3.2.8.3.4.1 Ultraviolet Exposure for Unprotected Eye or Skin

[HS3104] The system shall limit the spectral irradiance E_λ of the crew at wavelengths between 180 and 400 nm weighted by the spectral effectiveness function S_λ (given in Appendix C, table UV Radiation Exposure TLV and Spectral Weighting Function to:

Revision: E	Document No: CxP 70024
Release Date: 11/19/10	Page: 83 of 503
Title: Constellation Program Human-Systems Integration Requirements	

$$\sum_{180}^{400} \{E_{\lambda} S_{\lambda} t \Delta \lambda\} \leq 3 \text{ mJ/cm}^2 \text{ in any 24 hr period}$$

A table of weighted spectral irradiances versus permissible exposure times is given in Appendix C, table Permissible Ultraviolet Exposures (200–400 nm).

Rationale: This requirement is intended to prevent ocular and dermal injury caused by overexposure to ultraviolet radiation. A table of weighted spectral irradiances versus permissible exposure times is given in Appendix C, table Permissible Ultraviolet Exposures (200–400 nm) for discrete irradiances for reference. These limits will be met by default when the limits set in Appendix C, table UV Radiation Exposure TLV and Spectral Weighting Function are met. Any exposure to NIR must consider the entire pathway of the incident radiation prior to its interaction with a crewmember's body, including any concentration, diffusion, or filtering. For example, concentration of source radiation by optical instruments and attenuation by vehicle window systems or EVA visors need to be considered when evaluating the final radiation incident upon the crewmember. Protection from NIR may be accomplished through the reduction of effective irradiance or by limiting exposure times. Any means of providing NIR protection must not permanently degrade the ability of any optical systems to perform their intended function. The transmittance required for windows, visors, and other optical devices can be reconciled with protection from NIR through the use of temporary filters, proper material selection, apertures, beam stops or splitters, or other appropriate means.

3.3 SAFETY

This section is not intended to be a comprehensive collection of requirements related to safety. Additional safety topics are covered in other CxP documents and in other sections of this document.

3.3.1 Emergency Equipment Access

3.3.1.1 Emergency Equipment Access

[HS4022] The system shall provide access to emergency equipment within the time to address the emergency.

Rationale: In the case of an emergency, access to emergency equipment must occur quickly, allowing the crew to take the proper actions to mitigate the situation. Each emergency may have a unique time requirement and therefore a different constraint on access.

3.3.2 Mechanical Hazards

3.3.2.1 Corners and Edges Exposed during Nominal Operations

[HS4002] Corners and edges to which the crew is expected to be exposed during normal operations shall be rounded as specified in Appendix D, table Corner and Edge Rounding Requirements.

Revision: E	Document No: CxP 70024
Release Date: 11/19/10	Page: 84 of 503
Title: Constellation Program Human-Systems Integration Requirements	

Rationale: Rounded corners and edges help to prevent personnel injury and damage to protective equipment (such as gloves and pressure suits) from sharp edges during normal operations, which may include suited operations.

3.3.2.2 Corners and Edges Exposed during Maintenance

[HS4003] Corners and edges, except for equipment with functional sharp edges, to which the crew is only expected to be exposed during in-flight maintenance, shall be rounded to at least 0.01 inches.

Rationale: Rounded corners and edges help to prevent personnel injury and damage to protective equipment from sharp edges during maintenance. This does not apply to equipment with functional sharp edges, such as scissors, needles, and razor blades. This requirement is derived from NASA-STD-3000.

3.3.2.3 Corners and Edges of Loose Equipment

[HS4004] Loose equipment, except for equipment with functional sharp edges, shall have corners and edges rounded as specified in HS4004, table Minimum Edge and Corner Radii for Loose Equipment.

TABLE 3.3.2.3-1 - MINIMUM EDGE AND CORNER RADII FOR LOOSE EQUIPMENT

Equipment Mass		Minimum Edge radius mm (in)	Minimum Corner radius mm (in)
At Least kg (lb)	Less Than kg (lb)		
0.0 (0.0)	0.25 (0.6)	0.3 (0.01)	0.5 (0.02)
0.25 (0.6)	0.5 (1.1)	0.8 (0.03)	1.5 (0.06)
0.5 (1.1)	3.0 (6.6)	1.5 (0.06)	3.5 (0.14)
3.0 (6.6)	15.0 (33.1)	3.5 (0.14)	7.0 (0.3)
15.0 (33.1)	--	3.5 (0.14)	13.0 (0.5)

Rationale: Rounded corners and edges help to prevent personnel injury and damage to protective equipment from sharp edges during normal operations. Equipment that can become loose and become a projectile must have more rounded corners and edges. This requirement is derived from NASA-STD-3000.

3.3.2.4 Burrs

[HS4005] Exposed surfaces shall be free of burrs.

Rationale: Removal of burrs can help to prevent personnel injury and damage to protective equipment from sharp edges during normal operations.

3.3.2.5 Sharp Items

[HS4006] Functionally sharp items shall be prevented from causing injury to the crew or damage to equipment when not in use.

Revision: E	Document No: CxP 70024
Release Date: 11/19/10	Page: 85 of 503
Title: Constellation Program Human-Systems Integration Requirements	

Rationale: "Functionally sharp" items are those that, by their function, do not meet the requirement for exposed corners and edges (i.e., syringe, scissors, knife). These items must be prevented from causing harm when not in nominal use. Capping sharp items is one way of doing this.

3.3.2.6 Pinch Points

[HS4021] The system shall prevent pinch points from injuring the crew.

Rationale: Pinch points can cause injury to the crew but may exist for the nominal function of equipment (i.e., equipment panels). This may be avoided by locating pinch points out of the reach of the crew or providing guards to eliminate the potential to cause injury.

3.3.2.7 Interior Item Restraints

[HS4007] The system shall provide restraints for items that must be un-stowed during any portion of the mission.

Rationale: Many pieces of flight equipment, such as portable computing device and photographic equipment, may be deployed during on-orbit or extra-orbital maneuvers. These must be restrained so that they do not harm the crew or other equipment or become lost during EVA and/or IVA operations.

3.3.2.8 Holes

[HS4023] Round or slotted holes that are uncovered shall be less than 1.02 cm (0.4 in) or greater than 3.56 cm (1.4 in) in minimum dimension for equipment located inside habitable volumes.

Rationale: This requirement addresses entrapment hazards associated with suited and unsuited crewmembers who are required to operate IVA controls.

3.3.3 Electrical Hazards

3.3.3.1 Electrical Hazard Potential

[HS4008] The system shall protect the crew from electrical hazards per HS4008, table Electrical Hazard Potential and table Let-Go Current.

TABLE 3.3.3.1-1 - ELECTRICAL HAZARD POTENTIAL

Voltage/Current	Hazard Level
a. Worst-case credible failure results in exposure below threshold for shock:	none
1. Nonpatient with internal voltages below 30 volts rms	

2. Current below maximum leakage current as defined in requirements HS4008B and HS4008C	
b. Worst case credible failure results in exposure exceeding threshold for shock and is below let-go current (Table 3.3.3.1-2)	Critical (two controls required)
c. Worst case credible failure results in exposure exceeding let-go current (Table 3.3.3.1-2)	Catastrophic (three controls required)

TABLE 3.3.3.1-2 - LET-GO CURRENT

Frequency (Hz)	Threshold of Let-Go (milliamperes) (Based on 99.5 Percentile Rank of Adults) Maximum Total Peak Current (ac + dc components combined)
dc	40.0
15	8.5
2000	8.5
3000	13.5
4000	15.0
5000	16.5
6000	17.9
7000	19.4
8000	20.9
9000	22.5
10000	24.3
50000	24.3

Rationale: The values in the tables represent the currents beyond which a person is not able to release his/her grip if holding onto an electrically energized surface due to involuntary muscle contraction. The threshold current for let-go is dependent on the frequency and wave shape of the current.

3.3.3.2 Chassis Leakage Current - Nonpatient Equipment

[HS4008B] The system shall limit the chassis leakage current for nonpatient equipment to less than the values in HS4008B, table Chassis Leakage Current – Nonpatient.

TABLE 3.3.3.2-1 - CHASSIS LEAKAGE CURRENT - NONPATIENT

Enclosure or Chassis Leakage Current			
Grounded		Double Insulated	
(dc)	(ac ma)	(dc)	(ac ma)
ma	rms	ma	rms

0.700	0.500	0.350	0.250
-------	-------	-------	-------

Rationale: Chassis leakage current for nonpatient equipment must not be great enough to shock the crew.

3.3.3.3 Chassis Leakage Current - Patient Equipment

[HS4008C] The system shall limit the chassis leakage current for patient care equipment to less than the values in HS4008C, table Chassis Leakage Current – Patient.

TABLE 3.3.3.3-1 - CHASSIS LEAKAGE CURRENT - PATIENT

Patient Connection Leakage Current				
	Isolated (1)		Ordinary	
Patient	dc	ac ma	dc	ac ma
Interface	ma	rms	ma	rms
Invasive	0.014	0.010	Not Permitted	
Noninvasive	0.070 (1)	0.050 (1)	0.070	0.050
Enclosure or Chassis Leakage Current				
	Grounded		Double Insulated	
Patient	dc	ac ma	dc	ac ma
Interface	ma	rms	ma	rms
Noninvasive	0.140	0.100	0.070	0.050
Note:				
(1) If equipment labeling indicates "isolated," the maximum current is 0.014 ma dc/0.010 ma rms.				

Rationale: While some patient care equipment may produce current by function, the chassis leakage current must not be great enough to shock the crew.

3.3.4 Touch Temperature Limits

3.3.4.1 Hot Touch Temperature Limit

[HS4012] The system shall preclude the epidermis/dermis interface temperature from exceeding 44 °C (111 °F) during contact.

Rationale: Research by Greene et al. (1958) on human tolerance to heat pain showed that the pain threshold is reached at 43.7 °C skin temperature. Lloyd-Smith and Mendelssohn (1948) found the pain threshold to be 44.6 °C. Defrin et al. (2006) investigated heat pain threshold across the body and found the lowest level in the chest (42 °C), the highest in the foot (44.5 °C) and the hand was 43.8 °C. In a study by Moritz and Henriques (1947), 44 °C was the lowest temperature at which significant epidermal damage occurred, after exposure was sustained for 6 hours. As the contact temperature increased above 44 °C, the time to damage was shortened by approximately 50% for each 1 °C rise in

Revision: E	Document No: CxP 70024
Release Date: 11/19/10	Page: 88 of 503
Title: Constellation Program Human-Systems Integration Requirements	

temperature up to about 51 °C. Increasing contact pressure was not sufficient to increase the risk of thermal injury. At contact skin temperatures above 70 °C, it took less than 1 second to produce complete epidermal cell death. Pain threshold, versus damage threshold, should be used to a) preclude skin damage, and b) prevent a startle pain reaction (i.e. pulling a hand away quickly), which may cause injury to due flail.

3.3.4.2 Cold Touch Temperature Limit

[HS4012A] The system shall preclude the skin temperature from going below 10 °C (50 °F) during contact.

Rationale: Studies on the thermal performance of space suit gloves have shown that pain from cold occurring at hand skin temperatures of 10 °C was deemed tolerable (JSC 39116; Bue, 2009). Previous research on human tolerance to cold has shown that numbness occurs at 7 °C skin temperature (Provins and Morton, 1960) and risk of frostbite at 0 °C (Havenith et al., 1992). Pain threshold, versus damage threshold, should be used to: a) preclude skin damage, and b) prevent a startle pain reaction (i.e. pulling a hand away quickly), which may cause injury due to flail. In addition, staying above the numbness threshold is important, both because numbness can mask skin damage which may impact flight safety, and to allow normal touch sensation for tasks after contact with cold objects.

3.3.5 Fire Suppression Portability

3.3.5.1 Fire Suppression Portability

[HS4019] The system shall provide a portable fire suppression system.

Rationale: The crew must have portable fire-fighting capability, even if a fixed fire-fighting system is provided.

3.4 ARCHITECTURE

This section contains requirements for the overall layout of the vehicle's crew interfaces. This includes translation paths, mobility aids, restraints, hatches, windows, and lighting.

3.4.1 Configuration

3.4.1.1 Layout Interference

[HS5001] The system should separate functional areas whose functions would detrimentally interfere with each other.

Rationale: Co-location of unrelated activities could degrade operations resulting in increased workload and operational delays. This consideration will be difficult to meet in a small volume, but every effort should be made to separate functions and capabilities that could operationally conflict with each other, or that produce

Revision: E	Document No: CxP 70024
Release Date: 11/19/10	Page: 89 of 503
Title: Constellation Program Human-Systems Integration Requirements	

environmental conditions that will conflict with other tasks, e.g., glare, noise, vibrations, heat, odor, etc.

3.4.1.2 Layout Sequential Operations

[HS5002] The system should co-locate functional areas in which sequential operations are performed.

Rationale: Co-location of related, sequential functional work areas can reduce transit time, communication errors, and operational delays. This consideration may seem to be met simply because of a vehicle's small size, but every effort should be made to group functions and capabilities supporting a task in as efficient a manner as possible to reduce crew workload. For example, food stowage and food preparation areas should be located near one another to minimize the time required to retrieve food for meals.

3.4.1.3 Workstation Visual Demarcations

[HS5042] The system shall provide visual demarcations for adjacent workstations.

Rationale: Visual demarcations are needed to ensure that the crew is visually notified where adjacent workstations begin to prevent inadvertent use of other workstation elements. Examples are physical indentation in the metal, color coding, and outlining.

3.4.1.4 Workstation Orientation

[HS5003] Workstations shall provide all user-interface elements with the same orientation in roll as the sagittal plane of the restrained operator's head.

Rationale: Maintaining a consistent orientation of workstation elements minimizes crewmember rotational realignments needed to perform tasks that have directionally dependent components such as reading labels and displays. Inconsistent and varied display and control orientations may contribute to operational delays and errors. Given the complexity of some operations (e.g., piloting) a single orientation for all controls, displays, and labels may not be possible, but every effort should be made in design to minimize crewmember repositioning required to efficiently perform a task. This requirement is meant to ensure that all equipment at a workstation is aligned with the crewmember's head, even if the head is turned, so that an operating crewmember must only adjust their body orientation slightly in pitch and yaw at a workstation but does not need to adjust their body orientation in roll.

3.4.1.5 Location Coding

[HS7009] The system shall use a standard location coding system to provide a unique identifier for each predefined location within the vehicle in accordance with HS7036.

Revision: E	Document No: CxP 70024
Release Date: 11/19/10	Page: 90 of 503
Title: Constellation Program Human-Systems Integration Requirements	

Rationale: Location coding provides a clear method of referring to different locations within the vehicle and will serve as a communication and situational awareness tool when traversing the vehicle or un-stowing/stowing equipment. An example of Shuttle location coding is the numbering of mid-deck lockers: locker MF28H is located on the mid-deck (M), forward (F) surface, 28% of the way to the right of the total width of the surface and 122 cm (48 inches) from the top of the surface (H indicates 8 alphabetic increments of 15.2 cm [6 inches] from the top).

3.4.2 Translation Paths

3.4.2.1 Ingress and Egress Translation Paths

[HS5004] The system shall provide translation paths for ingress and egress (nominal and off-nominal) of suited crewmembers.

Rationale: Suited crewmembers must be able to get in and out of the vehicle on the ground or transfer between two docked vehicles in flight easily and quickly.

3.4.2.2 Internal Translation Paths

[HS5005] The system shall provide translation paths for the crew to conduct IVA operations.

Rationale: Translation paths are needed to support the safe and efficient movement of the crew throughout the vehicle. Translation paths around the ISS eating stations have disrupted crew rest and relaxation required during meals.

3.4.2.3 Crew Egress Translation Path - Ground

[HS5010] The system shall provide a translation path for assisted ground egress of an incapacitated suited crewmember.

Rationale: Incapacitated suited crewmembers may be unable to egress the vehicle on their own and may also be in a constrained position that requires assisted extraction. Long-duration Russian and United States missions have shown that muscles atrophy and bones lose calcium in microgravity. Also, the heart adjusts to gravity-free pressures. On return to earth and rapid onset of gravity, even healthy humans temporarily need assistance for some mobility tasks. Applicable pressurization cases can be defined by analysis.

3.4.2.4 Crew Ingress/Egress Translation Path in Space

[HS5053] The system shall provide an in-space translation path for assisted ingress and egress of an incapacitated pressurized-suited crewmember.

Rationale: Incapacitated pressurized-suited crewmembers may be unable to ingress the Orion on their own and may also be in a constrained position that requires assistance. This may include ingress from EVA or ingress/egress to/from the Orion from EVA or any vehicle or module to which the Orion is

Revision: E	Document No: CxP 70024
Release Date: 11/19/10	Page: 91 of 503
Title: Constellation Program Human-Systems Integration Requirements	

docked. Crew in a pressurized suit is the bounding case. This requirement also includes assisted ingress and egress for crew in an unpressurized suit as well as unsuited crew.

3.4.3 Restraints and Mobility Aids

3.4.3.1 Standard Restraints and Mobility Aids

[HS5006] Restraints and mobility aids should be standardized across Constellation Systems.

Rationale: Standardization of restraints and mobility aids will reduce learning and recognition times, which is especially important in emergencies.

3.4.3.2 IVA Mobility Aids

[HS5007] The system shall provide mobility aids for the crew to conduct IVA operations.

Rationale: Mobility aids, such as hand and foot restraints, allow crewmembers to efficiently move from one location to another in 0 g, as well as reduce the likelihood of inadvertent collision into hardware that may cause damage to the vehicle or injury to the crew. Early experience in the Skylab program showed the problems of movement in microgravity. Stopping, starting, and changing direction all require forces that are best generated by the hands or feet. Appropriately located mobility aids make this possible. Mobility aids must be designed to accommodate a pressurized suited crewmember by providing clearance, non-slip surfaces, and non-circular cross sections. Without predefined mobility aids, personnel will use available equipment that may be damaged from induced loads.

3.4.3.3 Workstation Restraints

[HS5008] The system shall provide restraints to allow crewmembers to perform two-handed operations at a workstation in 0 g.

Rationale: Maintaining a static position and orientation at a workstation is necessary to ensure that controls can be activated without motion being imparted to the crewmember. Without gravity to hold an individual onto a standing or sitting surface, the body will float or move in the opposite direction of an applied force. The cognitive and physical work required to maintain body position during a task can interfere with the task performance. Activities that use both hands must not require handholds to maintain position at a workstation but may require restraints such as foot loops, straps, or harnesses.

3.4.3.4 Ingress and Egress Mobility Aids

[HS5009] The system shall provide mobility aids for ingress and egress (nominal and off-nominal) of suited crewmembers.

Revision: E	Document No: CxP 70024
Release Date: 11/19/10	Page: 92 of 503
Title: Constellation Program Human-Systems Integration Requirements	

Rationale: Because of the limited maneuverability of a suited crewmember, mobility aids are required to allow crewmembers to safely and efficiently ingress and egress the vehicle. Applicable pressurization cases can be defined by analysis.

3.4.3.5 Commonly Distinguishable Handrails

[HS5052] IVA handrails not used for flight crew egress should be colored Blue #25102 per FED-STD-595, Colors Used in Government Procurement.

Rationale: During emergencies, crews need to be able to quickly discern mobility aids from the surrounding structures. Visual cues such as color coding may aid in this function. Commonality among visual cues is important so that crews can easily distinguish intended mobility aids from non-mobility aids that may be damaged by the application of crew-induced loads. Blue #25102 is the color used on International Space Station for IVA handrails.

3.4.3.6 Egress Handrails

[HS5054] IVA handrails intended for use during flight crew egress should be colored Yellow #33538 per FED-STD-595, Colors Used in Government Procurement.

Rationale: During emergencies, crews need to be able to quickly discern mobility aids from the surrounding structures. Visual cues such as color coding may aid in this function. Commonality among visual cues is important so that crews can easily distinguish intended mobility aids from non-mobility aids that may be damaged by the application of crew-induced loads. Yellow #33538 is the color used on International Space Station to denote "caution." Handrails used both for egress and non-egress functions should be yellow.

3.4.4 Hatches

3.4.4.1 Hatch Operation

3.4.4.1.1 Nominal Hatch Operation

3.4.4.1.1.1 Hatches Operable Inside and Outside

[HS5013] Hatches shall be operable from both the inside and outside.

Rationale: Hatch operation includes unlatching/opening or closing/latching the hatch. This requirement addresses both nominal and contingency operations, including isolation of the vehicle from other vehicles in an emergency (e.g., depress, fire, toxic spill). The side hatch will be accessed from the inside during EVA, pad egress, and post-landing egress, and accessed from the outside in the case where docking fails and access to the vehicle must occur through the side hatch via EVA. The docking hatch will be accessed from the Orion side after docking with the Altair/ISS, and from the Altair/ISS side upon return. Crew

Revision: E	Document No: CxP 70024
Release Date: 11/19/10	Page: 93 of 503
Title: Constellation Program Human-Systems Integration Requirements	

should be able to both ingress and egress the ground safe haven following emergency pad egress unassisted.

3.4.4.1.1.2 Hatches Operable in 60 Seconds

[HS5043] Hatches shall be operable in no more than 60 seconds.

Rationale: Hatch operation includes unlatching/opening or closing/latching the hatch. Excessively long operating times can delay crews on both sides of a hatch that would prevent ingress or egress. Sixty seconds is based on engineering judgment related to easily operable hatch design without complicating hatch design. The requirement applies to both flight vehicles and hatches in the ground safe haven following emergency pad egress. This duration does not include pressure equalization between flight vehicles.

3.4.4.1.1.3 Hatches Operable Without Tools

[HS5044] Hatches shall be operable without the use of tools.

Rationale: Hatch operation includes unlatching/opening or closing/latching the hatch. Lost or damaged tools will prevent the hatches from being opened or closed, which may result in Loss of Crew (LOC) or Loss of Mission (LOM). Ground operation of flight vehicle hatches and suited crew operation of hatches in the ground safe haven following emergency pad egress should not require tools. Personal Protective Equipment (PPE) used to protect ground personnel from temperature extremes after vehicle reentry is not categorized as a tool; therefore, it is not prohibited by this requirement.

3.4.4.1.1.4 Hatches Operable by Suited Crewmembers

[HS5045] Hatches shall be operable by a single suited crewmember.

Rationale: Based on experience, opening a hatch by a suited crewmember is more difficult than by an unsuited crewmember due to reduced reach, mobility, and limited manual dexterity due to gloved hands and the pressurization level of the suit.

3.4.4.1.1.5 Unlatching Hatches

[HS5046] Vehicle hatches shall require two distinct and sequential operations to unlatch.

Rationale: Inadvertent hatch opening and subsequent cabin depressurization would be catastrophic. Requiring two separate, distinct operations helps to ensure that the hatch will not be unlatched through accidental contact.

Revision: E	Document No: CxP 70024
Release Date: 11/19/10	Page: 94 of 503
Title: Constellation Program Human-Systems Integration Requirements	

3.4.4.1.2 Pressure Equalization of Hatches

3.4.4.1.2.1 Hatch Manual Pressure Equalization Inside and Outside

[HS5014] The system shall provide manual pressure equalization from both the inside and outside.

Rationale: Air pressure must be equalized on either side of a hatch to safely open the hatch. In some vehicle failure scenarios, non-manual methods for pressure equalization may fail. Manual pressure equalization will enable hatch opening regardless of vehicle status.

3.4.4.1.2.2 Hatch Manual Pressure Equalization by Suited Crewmembers

[HS5048] The system shall allow manual pressure equalization by a pressurized suited crewmember.

Rationale: Based on experience, manual operations performed by pressurized suited crewmembers are more difficult due to reduced reach, mobility, and limited manual dexterity due to gloved hands and the pressurized suit. In some vehicle failure scenarios, non-manual methods for pressure equalization may fail. Manual pressure equalization will enable hatch opening regardless of vehicle status.

3.4.4.2 Hatch Indications

3.4.4.2.1 Hatch Status Indications

3.4.4.2.1.1 Hatch Latch Position

[HS5049] The system shall provide latch position status from the inside and outside of each hatch.

Rationale: Indication of latch status on both sides of the hatch will allow both ground personnel (launch pad) and flight crew to verify that each hatch is latched. In combination with hatch closure status, this indicates proper security of the hatch.

3.4.4.2.1.2 Hatch Closure Indication

[HS5016] The system shall provide hatch closure indication from the inside and outside of each hatch.

Rationale: Indication of hatch closure status on both sides of the hatch will allow both ground personnel (launch pad) and flight crew to verify that each hatch is closed. In combination with latch position status, this indicates proper security of the hatch. Hatch closure implies that the hatch is in proper position to be latched.

Revision: E	Document No: CxP 70024
Release Date: 11/19/10	Page: 95 of 503
Title: Constellation Program Human-Systems Integration Requirements	

3.4.4.2.1.3 Hatch Pressure Difference Measurement

[HS5050] The system shall provide direct pressure difference measurement on the inside and outside of each hatch.

Rationale: Direct pressure difference measurement on both sides of the hatch will allow both ground personnel and flight crew to see the changes in pressure across the hatch and to know when the pressure difference is low enough to safely open the hatch. This function would be used as-needed, and pressure difference indication is not required at all times. However, the pressure difference indication must not require ground personnel or flight crew to call up a vehicle display.

3.4.4.2.1.4 Hatch Visual Observation

[HS5017] The system shall provide a window for direct, non-electronic visual observation of the environment on the opposite side of the hatch.

Rationale: Direct visual observation of the environment on the opposite side of the hatch allows the flight crew to determine the conditions or obstructions (such as the presence of fire or debris) on the other side of the hatch for safety purposes.

3.4.5 Windows

3.4.5.1 Window Optical Properties

[HS5019] System windows shall meet or exceed the optical performance properties consistent with tasking as specified in JSC 63307, Requirements for Optical Properties for Windows Used in Crewed Spacecraft.

Rationale: The windows must be of sufficient optical performance so that they do not degrade visual acuity and performance. JSC 63307 provides optical properties for different types of windows according to their associated tasks. These optical properties provide the system window with the optical properties and performance necessary to support a given task. Orion tailors these windows optical quality requirements in CxP 72407, Orion Crew Exploration Vehicle Window Optical Properties Requirements. Reference (i) "International Space Station Cupola Scratch Pane Window Optical Test Results," ATR-2003(7828)-1, January 17, 2003, and (ii) the Scientific and Technical Information Center Vehicle Integration and Test Office Window Testing report available at <http://stic.jsc.nasa.gov/eresources/Imagery/index.html>. To permit use of telephoto camera and high-definition video equipment, the windows must be of sufficient optical performance so that images retrieved will not be significantly degraded and distorted.

Revision: E	Document No: CxP 70024
Release Date: 11/19/10	Page: 96 of 503
Title: Constellation Program Human-Systems Integration Requirements	

3.4.5.2 Window Viewing for Piloting Tasks

[HS5021] The system shall provide a minimum of two windows for direct, non-electronic viewing for piloting tasks.

Rationale: Because of the criticality of piloting tasks to the success of the mission and safety of the crew, the most reliable method of maintaining external observation is needed. Windows are reliable and familiar to pilots, and do not have many of the failure modes associated with cameras and display systems.

3.4.5.3 Window for External Viewing Observation

[HS5022] The system shall provide a window for direct, non-electronic through-the-hull viewing and observation from the interior to the exterior and vice versa.

Rationale: Windows provide situational awareness and allow vehicle inspection and may be used for science and navigation. Experience in past programs has shown that windows will be used for photography. This requirement may be met with the use of an existing window such as a piloting window if one is already planned for incorporation into the system.

3.4.5.4 Window for Motion Imagery and Photography

[HS5055] The system shall support motion imagery and photography using lenses with apertures up to 100 mm in diameter through at least one window without causing image degradation on all human tended flight elements.

Rationale: Windows are routinely used for motion imagery and photography for a variety of purposes, which can include safety and engineering evaluations, documentation of operational activities and unusual events, and public relations. High resolution photography is of particular interest for lunar missions. The imagery retrieved through a window for such purposes must not be degraded by the window.

3.4.5.5 Window Cover, Shade, and Filter Removal or Replacement Without Tools

[HS5051] System window covers, shades, and filters that are designed to be removed and replaced during flight shall be removable and replaceable without the use of tools.

Rationale: Where covers, shades, and filters are used, their removal and replacement must not be a burden to the crew; having to retrieve, use, and subsequently stow tools for this purpose would be an unnecessary burden on the crew and would consume valuable crew time.

Revision: E	Document No: CxP 70024
Release Date: 11/19/10	Page: 97 of 503
Title: Constellation Program Human-Systems Integration Requirements	

3.4.5.6 Window Cover, Shade, and Filter Removal or Replacement in 10 Seconds

[HS5027] Window covers, shades, and filters that are designed to be removed and replaced during flight shall be removable in less than 10 seconds and replaceable in less than 10 seconds.

Rationale: The removal and replacement or the operation from closed to opened and opened to closed of protective covers (transparent - clear), shades (opaque), and filters (transparent - tinted) must not be a time burden to the crew. Having the ability to remove or open and replace or close protective covers, shades, and filters quickly ensures their proper use and thus ensures that appropriate protection for the windows and the crew is in place when necessary. Designs such as the Shuttle's window shades and side hatch filter and the ISS's Window Observational Research Facility (WORF) and AgCam Bump Shields actually take less than 5 seconds each to remove and replace (Shuttle's Shades and Side Hatch Filter) or retract (open) and deploy (close) (ISS's Bump Shields).

3.4.5.7 Obstruction

[HS5030] The system should define keep out zones to prevent the obstruction of windows' operational fields of view by any fixed equipment according to guidelines provided in Appendix M.

Rationale: Fixed equipment, such as window instrumentation, hardware, or a condensation prevention system, that would obscure the field of view from the normal crew position for window viewing may interfere with piloting and photography tasks. Sufficient volume immediately around the window must also be provided to allow a helmeted crewmember to view through the window or two non-helmeted crewmembers to view through the window simultaneously. Transparent, conductive coatings are readily available for use in electro-thermal condensation prevention systems in lieu of wires that would be visible in the field of view (e.g., rear window defoggers on automobiles). These coatings may in some cases also serve as an antireflective coating.

3.4.5.8 Window and Internal Darkening

[HS5031] Each system window shall be equipped with an opaque shade or shutter that prevents external light from entering the crew compartment such that the interior light level is reduced to 2 lux at 0.5 m (20 in) from each window.

Rationale: External illumination interferes with crew sleep and can interfere with onboard still and motion imaging as well as the crew's circadian rhythm. Shades and shutters block external illumination from entering the habitable compartments through windows.

Revision: E	Document No: CxP 70024
Release Date: 11/19/10	Page: 98 of 503
Title: Constellation Program Human-Systems Integration Requirements	

3.4.5.9 Window Proximity Finishes

[HS5032] System window frame assemblies and supporting structure within 0.15 m (6 in.) from the perimeter of any window in all directions both internally and externally shall have a flat, black finish or coating with reflectance less than 10% over a wavelength range of 400–800 nm so that stray light is minimized and spurious reflections are reduced especially from between the panes.

Rationale: Many tasks require a clear viewing through the windows. Stray light and spurious reflections are reduced when lusterless finishes are used on the window structure, around the window, on interior and exterior surfaces adjacent to the window that are visible to the observer, and especially on structure visible between the panes. This permits viewing through the window without these unwanted light sources. A number of commercially available black coatings meet these requirements such as Z-306 paint, which has a history of use within many NASA programs. This paint has a diffuse reflectance of around 5% across the visible and infrared spectra. The wavelength range is specified into the near infrared because some black finishes are highly reflective in the infrared and can cause a non-ionizing radiation hazard and/or discomfort. This requirement includes fasteners, handrails, and connectors but does not include labeling, switch panels, switches, and switch guards. These items should have a lusterless surface finish or coating. Interior surfaces opposite the window should also have a surface finish that meets the diffuse reflectance requirement specified above where possible.

3.4.6 Lighting

3.4.6.1 Interior Lighting

3.4.6.1.1 Lighting Level by Task

[HS5035] The system shall provide the levels of light specified in HS5035, table Lighting Level by Task through a combination of interior lights.

TABLE 3.4.6.1.1-1 - LIGHTING LEVEL BY TASK

Task	Illumination (lux)	Measurement Location
Invasive wound care (cleaning/suturing)	≥ 500	At treatment surface (mucosa or skin)
Reading 6 point font (non self-illuminated text or graphics)		On the surface to be read
General Lighting	≥ 350	On most surfaces in vehicle common areas

Revision: E	Document No: CxP 70024
Release Date: 11/19/10	Page: 99 of 503
Title: Constellation Program Human-Systems Integration Requirements	

Task	Illumination (lux)	Measurement Location
Reading 12 point font (non self-illuminated text or graphics)		On the surface to be read
Handwriting/tabulating - ink on white paper	≥ 320	On the paper
Fine maintenance and repair work		On the affected component surface
Food preparation	≥ 300	On food preparation surfaces
Dining	≥ 250	On intended dining surfaces
Grooming		On the face located 50 cm. above center of mirror

Revision: E	Document No: CxP 70024
Release Date: 11/19/10	Page: 100 of 503
Title: Constellation Program Human-Systems Integration Requirements	

LIGHTING LEVEL BY TASK (CONCLUDED)

Task	Illumination (lux)	Measurement Location
Non-invasive wound care		On the wound
Exercise		On the exercise equipment
Video conferencing		On the face(s)
Gross Maintenance & housekeeping		On surfaces involved
Mechanical assembly		On the components involved
Manual controls	≥ 200	On the visible control surfaces
Panel - dark legend on light background		On the panel surface
Waste management	≥ 150	On the seat of the waste collection system
Translation	≥ 110	At all visible surfaces within the habitable volume
Panel - light legend on dark background	≥ 50	On the panel surface
Emergency equipment shutdown	≥ 30	On controls
Night lighting	≤ 1	At crewmember eyes
Emergency egress	≥ 10	On protruding surfaces
Crew sleep in dedicated sleep quarters	≤ 0.02	At crewmember eyes

Rationale: A wide range of crew tasks is expected to be performed within the vehicle. The lighting levels will vary dependent upon the task being performed. For instance, cabin reconfiguration after orbit insertion may require simultaneous reading of labels and checklists, crew translation, mechanical assembly, and manual control at a variety of vehicle locations, each of which requires sufficient lighting without blockage from crew and equipment in transit. Similarly, rendezvous and proximity operations may require general cabin darkening for out-the-window viewing but sufficient lighting for crew translation and manual control. A single type of lighting at a single illumination level will be insufficient to support all tasks; therefore, both general and task illumination will be required. The light level 500 lux is required in the vehicle so that the crew can perform tasks without frequently requiring dedicated task lighting. The Illuminating Engineering Society of North America (IESNA) states in the ninth edition of the IESNA Lighting Handbook, pages 10-13 and 10-15 that illumination at the 500 lux level is defined to be for "performance of visual tasks of high contrast and small size or low contrast and large size." This meets the requirements of all the tasks in HS5035, table Lighting Level by Task. Examples include reading small

Revision: E	Document No: CxP 70024
Release Date: 11/19/10	Page: 101 of 503
Title: Constellation Program Human-Systems Integration Requirements	

text (6 point), examining photographs of moderate detail, and minor medical care. Portable lights may be used to supplement general and task lighting for off-nominal tasks and vehicle configurations, or where general illumination is reduced due to temporary blockage by equipment or stowage. It is desirable to provide a sleep environment with minimal lighting. The level specified as "Crew sleep in dedicated sleep quarters" in this table is applicable for dedicated crew sleep areas rather than sleep occurring in common areas, and is intended to provide lighting levels that are as low as is practical to implement and measure. The level specified as "Night lighting" is applicable for activities including sleep that occur in common areas, including vehicles that do not have dedicated sleep quarters. Night lighting levels are intended to provide a dark enough environment to accommodate crew sleep without requiring significant mitigations by the crew to prepare for sleep periods. The "Night Lighting" levels specified in the table are applicable to mission durations longer than three days. For common sleep areas, location of eyes may be loosely defined; thus, likely location of eyes should be considered.

3.4.6.1.2 Interior Light Adjustability

[HS5034B] Interior lights shall be adjustable (dimnable) from their minimum output level (equal to less than 5% of maximum luminous intensity) to their maximum luminous intensity.

Rationale: Interior lighting must be adjustable to permit the crew to use out-the-window views when there is little external light, for example during rendezvous, and to allow the selection of lower light levels when crewmembers are resting.

3.4.6.2 Lighting Controls

3.4.6.2.1 General Light Control

[HS5039] Controls for interior lighting within each habitable volume shall be located within that volume.

Rationale: Operators should be able to see the effect of changes to lighting controls without changing their location or leaving the module.

3.4.6.2.2 Workstation Light Control

[HS5040] The system shall provide workstation lighting control to a crewmember who is restrained at the workstation.

Rationale: Individual tasks or crewmembers may require or desire higher or lower lighting levels than that provided for other tasks or crewmembers.

Revision: E	Document No: CxP 70024
Release Date: 11/19/10	Page: 102 of 503
Title: Constellation Program Human-Systems Integration Requirements	

3.4.6.2.3 Workstation Light Position Adjustment

[HS5041] The system shall provide a means for a crewmember restrained at the workstation to adjust the position of the task light(s) for those workstations that require repositionable workstation task lighting.

Rationale: Adjusting the position of a workstation light may be required during operations. It would create a hazard if a crewmember were required to leave the workstation during critical periods such as ascent, rendezvous, or entry.

3.4.6.2.4 Lighting ON/OFF Control

[HS5056] Interior lighting shall include the provision for turning power to the lights On and Off, with a positive indication of power setting.

Rationale: HS5034B requires that interior lighting be adjustable to a minimum luminous intensity less than 5% of maximum luminous intensity. Luminous intensity levels less than 5% of maximum but greater than zero may interfere with operations requiring that the crew module illumination be minimal for out-the-window viewing, photography, and crew sleep. Further, lighting may cause undesirable glare or cause discomfort to crew performing operations very close to the lights. Light sources should be capable of being turned completely Off and returned to On. Selection of the Off or On condition should be verifiable by the operator through means other than observing light emission from the source to distinguish the Off setting from a light system failure. Possible On/Off indications include switch detent, switch toggle position, power pilot lamp, etc.

3.5 CREW FUNCTIONS

The following section discusses the design and layout requirements of facilities for specific crew functions within the vehicle.

3.5.1 Food Preparation

3.5.1.1 Cross-Contamination

3.5.1.1.1 Cross-Contamination Prevention

[HS6001] The system should prevent cross-contamination between food preparation and personal hygiene areas, and between food preparation and body waste management areas.

Rationale: This requirement helps protect crew health by limiting the transfer of microorganisms to the food preparation area.

3.5.1.1.2 Cross-Contamination Separation

[HS6002] The distance between food preparation and body waste management areas should be as large as possible.

Revision: E	Document No: CxP 70024
Release Date: 11/19/10	Page: 103 of 503
Title: Constellation Program Human-Systems Integration Requirements	

Rationale: This requirement is designed to prevent interference of body waste management functions with food preparation. Shuttle and ISS designs both put the waste management facilities unnecessarily close to the food preparation areas. It is a design goal because the other constraints on the layout of the spacecraft interior may preclude meeting any specific separation between the food preparation area and, for example, the body waste management area.

3.5.1.2 Preparation

3.5.1.2.1 Heating

[HS6003] The system shall heat food and drinks to between 68 °C (155 °F) and 79 °C (175 °F).

Rationale: Heating is required for subjective quality of food. Maintaining the temperature of rehydrated food above 68 °C (155 °F) helps prevent microbial growth. Foods heated to above 79 °C (175 °F) could cause heat-related injury to crewmembers. The vehicle should provide the ability to heat non-rehydrated foods.

3.5.1.2.2 Rehydration

[HS6004] The system shall allow the crew to rehydrate food and drinks with potable water.

Rationale: Many foods must be rehydrated prior to consumption because (i) the water content of food is an important component of daily water intake, and (ii) people are used to the taste and texture of hydrated foods. Some foods must be rehydrated with hot water to ensure activation of certain chemical processes.

3.5.1.2.3 In-Flight Food Preparation Time

[HS6005] While in-flight, the system should allow the crew to prepare each meal for all crewmembers within a single 30-minute period.

Rationale: The water delivery and food heating systems must support meal preparation for the full crew if the mission schedule requires that they eat meals together. This 30-minute period is based on a 1-hour time lined meal, which includes 5 minutes for un-stowing, 25 minutes for food preparation, 20 minutes for eating, 3 minutes for wiping and cleaning, 2 minutes for trash stowage, and 5 minutes for re-stow of meal related items. The intent of this requirement is not to preclude the preparation of meals that may take longer, if planned, but to provide vehicle capability for all crewmembers to eat a hot meal together within a scheduled 1-hour meal time.

3.5.1.2.4 Lunar Surface Food Preparation Time

[HS6102] While on the lunar surface, the system shall allow the crew to prepare each meal for four crewmembers within a single 30-minute period.

Revision: E	Document No: CxP 70024
Release Date: 11/19/10	Page: 104 of 503
Title: Constellation Program Human-Systems Integration Requirements	

Rationale: The water delivery and food heating systems must support meal preparation for the full crew, if the mission schedule requires that they eat meals together. This 30-minute period is based on a 1-hour time lined meal, which includes 5 minutes for un-stowing, 25 minutes for food preparation, 20 minutes for eating, 3 minutes for wiping and cleaning, 2 minutes for trash stowage, and 5 minutes for re-stow of meal related items. The intent of this requirement is not to preclude the preparation of meals that may take longer, if planned, but to provide vehicle capability for all crewmembers to eat a hot meal together within a scheduled 1-hour meal time.

3.5.1.3 Food System

3.5.1.3.1 Food System

[HS6059] The system shall provide a food system with a diet including the nutrient composition per HS6059, table Nutrition Composition Breakdown.

TABLE 3.5.1.3.1-1 - NUTRITION COMPOSITION BREAKDOWN TABLE

Nutrients	Daily Dietary Intake
Protein	0.8 g/kg
	And ≤ 35% of the total daily energy intake
	And 2/3 of the amount in the form of animal protein and 1/3 in the form of vegetable protein
Carbohydrate	50-55% of the total daily energy intake
Fat	25-35% of the total daily energy intake
Ω-6 Fatty Acids	14 g
Ω-3 Fatty Acids	1.1-1.6 g
Saturated fat	<7% of total calories
Trans fatty acids	<1% of total calories
Cholesterol	<300 mg/day
Fiber	10-14 grams/4,187 kJ
Fluid	1-1.5 mL/4,187 kJ
	And ≥ 2,000 mL

Revision: E	Document No: CxP 70024
Release Date: 11/19/10	Page: 105 of 503
Title: Constellation Program Human-Systems Integration Requirements	

NUTRITION COMPOSITION BREAKDOWN TABLE (CONCLUDED)

Nutrients	Daily Dietary Intake
Vitamin A	700-900 µg
Vitamin D	25 µg
Vitamin K	Women: 90 µg
	Men: 120 µg
Vitamin E	15 mg
Vitamin C	90 mg
Vitamin B12	2.4 µg
Vitamin B6	1.7 mg
Thiamin	Women: 1.1 µmol
	Men: 1.2 µmol
Riboflavin	1.3 mg
Folate	400 µg
Niacin	16 mg NE
Biotin	30 µg
Pantothenic Acid	30 mg
Calcium	1,200 – 2,000 mg
Phosphorus	700 mg
	And ≤ 1.5 x calcium intake
Magnesium	Women: 320 mg
	Men: 420 mg
	And ≤ 350 mg from supplements only
Sodium	1,500 – 2,300 mg
Potassium	4.7 g
Iron	8–10 mg
Copper	0.5–9 mg
Manganese	Women: 1.8 mg
	Men: 2.3 mg
Fluoride	Women: 3 mg
	Men: 4 mg
Zinc	11 mg
Selenium	55–400 µg
Iodine	150 µg
Chromium	35 µg

Revision: E	Document No: CxP 70024
Release Date: 11/19/10	Page: 106 of 503
Title: Constellation Program Human-Systems Integration Requirements	

Rationale: A balanced diet is required to optimize crewmember health and performance. The values identified in HS6059, table Nutrition Composition Breakdown are derived from the Nutrition Requirements, Standards, and Operating Bands for Exploration Missions.

3.5.1.3.2 Metabolic Intake

[HS6060] The system shall provide each crewmember with an average of 12,707 kJ (3,035 kilo-calories) per day.

Rationale: The Estimated Energy Requirements (EER) for space missions is based on Total Energy Expenditure (TEE), using an activity factor of 1.25 (active) along with the individual's age, body mass (kg), and height (m) in the following calculations: EER for men 19 years and older $EER = 622 - 9.53 \times \text{Age [y]} + 1.25 \times (15.9 \times \text{Mass [kg]} + 539.6 \times \text{Ht [m]})$ and EER for women 19 years and older $EER = 354 - 6.91 \times \text{Age [y]} + 1.25 \times (9.36 \times \text{Mass [kg]} + 726 \times \text{Ht [m]})$. The value given in the requirement is based on the projected values for a mean male astronaut population in the year 2015 with a stature of 178.6 cm and a weight of 82.4 kg. The age used for these calculations is 45 years old. This requirement is derived from the Nutrition Requirements, Standards, and Operating Bands for exploration missions.

3.5.1.3.3 Metabolic Intake for EVA

[HS6062] The system shall provide no less than an additional 837 kJ (200 kilocalories) above nominal metabolic intake as defined in HS6060, similar in nutrient composition to the rest of the diet per HS6059, per EVA hour for crewmembers performing EVA operations.

Rationale: Additional nutrients, including fluids, are necessary during suited operations as crewmember energy expenditure is greater during those activities. The additional 200 kilocalories, based on metabolic energy replacement requirements from moderate to heavy EVA task, allow the crewmember to maintain lean body weight during the course of the mission. Lean body (especially muscular) weight maintenance is a key component of preserving crew health during the missions and keeping performance at a level required to complete mission objectives.

3.5.2 Personal Hygiene

3.5.2.1 Personal Hygiene Items

[HS6105] The system shall provide personal hygiene items for each crewmember.

Rationale: Each crewmember needs personal hygiene capabilities for body cleansing, oral hygiene, and personal grooming throughout each space mission. Personal hygiene equipment and supplies must accommodate the physiological differences in male and female crewmembers in the microgravity environment. The supplies should also be able to meet the personal needs and comfort of the

Revision: E	Document No: CxP 70024
Release Date: 11/19/10	Page: 107 of 503
Title: Constellation Program Human-Systems Integration Requirements	

crewmembers to the extent possible in the space module environment. Personal hygiene includes the capability for crewmembers to cleanse their body and hair; to perform oral hygiene tasks related to tooth, mouth, and gum care; to condition their skin sufficiently to prevent drying and/or cracking; to shave body hair; to cut hair to maintain the length within mission and/or personal requirements; to trim nails; and to control body odor.

3.5.2.2 Personal Hygiene Privacy

[HS6009] The system shall provide visual privacy for personal hygiene.

Rationale: Certain hygiene functions require a degree of privacy, especially in a vehicle in which other crewmembers may be performing other functions simultaneously.

3.5.2.3 Personal Hygiene Stowage

[HS6010] The system should provide readily accessible stowage for personal hygiene supplies.

Rationale: Personal hygiene supplies, such as tissues and towels, may need to be accessed rapidly.

3.5.2.4 Personal Hygiene Trash

[HS6012] The system should provide readily accessible trash collection for disposable personal hygiene supplies.

Rationale: Crewmembers require readily accessible trash collection for disposable personal hygiene supplies to minimize crew exposure to the used items. Access to trash collection hardware or compartments should not require the use of any tools or reconfiguration of vehicle hardware.

3.5.2.5 Full Body Visual Privacy

[HS6027] The system shall provide full body visual privacy for body waste management.

Rationale: In a small vehicle, provisions for privacy during waste management allow activities such as videoconferences to proceed uninterrupted.

3.5.2.6 Body Self-Inspection and Cleaning

[HS6028] The system should provide a means and sufficient volume for crewmembers to perform bodily self-inspection and cleaning after urination and defecation.

Rationale: In 0 g, body waste can float. Therefore, after waste management, it is important for crewmembers to verify that they are clean.

3.5.3 Body Waste Management

Revision: E	Document No: CxP 70024
Release Date: 11/19/10	Page: 108 of 503
Title: Constellation Program Human-Systems Integration Requirements	

3.5.3.1 Vomitus Collection and Containment

[HS6013] The system shall provide for the collection and containment of vomiting events of 0.5 L each as indicated in HS6013, table Vomitus Collection and Containment.

TABLE 3.5.3.1-1 - VOMITUS COLLECTION AND CONTAINMENT

Mission	Design-to Number of Vomiting Events Per Crewmember Per Mission
Orion to or from ISS	8
Orion Lunar Mission	8
Altair	1

Rationale: The total capacity of 4 L for Orion missions should accommodate four in-flight events with a total volume of 2 L for the Space Adaptation Syndrome (SAS) portion of the mission and 4 events post-flight with a total volume of 2 L for a possible water landing. The total capacity of 0.5 L per crewmember per mission for Altair missions should accommodate 1 in-flight event per crewmember to account for possible food-borne vomiting events. Vomiting and its associated odor, mainly produced by the compound putrescine, may trigger a bystander nausea and vomiting reaction in adjacent crewmembers located in close proximity in an enclosed space. Space Adaptation Syndrome (SAS) occurs in up to 70% of first time fliers (30% of whom may experience vomiting) during the first 48-72 hours of microgravity. In addition, a possible water landing may cause crewmembers to succumb to sea sickness. The average number of vomiting episodes per crewmember will vary from 1 to 6 per day, over a 2- to 3-day period. Regurgitation of the entire stomach contents will result on average in 0.2 to 0.5 L of vomitus per event. Stowage and disposal should be adequate for a worst-case number of involved crew, severity and duration of symptoms, as well as volume of gastrointestinal contents regurgitated.

3.5.3.2 Feces

3.5.3.2.1 Fecal Wipes

[HS6016] The system shall provide collection and containment of consumable wipe materials used for fecal matter.

Rationale: Used consumable wipe materials must be collected and contained in a manner that minimizes possible escape of fecal contents into the habitable vehicle during microgravity operations because of the high content of possibly pathogenic bacteria contained in the stool and because of the potential of injury to crewmembers and hardware that could result from such dissemination. The collection capacity accounts for the average healthy adult stool output/day. Historically, on the Shuttle, a total of 20 wipes per crewmember per day

Revision: E	Document No: CxP 70024
Release Date: 11/19/10	Page: 109 of 503
Title: Constellation Program Human-Systems Integration Requirements	

(including urine and feces uses) were flown for waste management. The Shuttle wipes packages hold 40 wipes and have the following dimensions: 20.3 cm x 10.9 cm x 4.6 cm (8.0 in x 4.3 in x 1.8 in).

3.5.3.2.2 Feces per Day

[HS6017] The system shall provide collection and containment of an average of 150 grams (by mass) and 150 mL (by volume) of fecal matter per crewmember per defecation at an average of two defecations per day.

Rationale: Fecal waste collection must be performed in a manner that minimizes possible escape of fecal contents into the habitable vehicle during microgravity operations because of the high content of possibly pathogenic bacteria contained in the stool. In addition, there is the potential of injury to crewmembers and hardware that could result from such dissemination. The collection capacity accounts for the average healthy adult stool output/day. The number of defecations per day is individually variable ranging from two times per week to five times per day, with the assumed average of two times per day. EVA suits will need to accommodate for fecal waste collection and containment during all suited activities. Suited activities are not expected to exceed 10 hours. From a waste management system standpoint, normal feces should not be accounted for on days when crewmembers are afflicted with diarrhea.

3.5.3.2.3 Feces per Event

[HS6020C] The system shall provide collection and containment of 500 grams (by mass) and 500 mL (by volume) of fecal matter per crewmember in a single event.

Rationale: Fecal waste collection must be performed in a manner that minimizes possible escape of fecal contents into the habitable vehicle during microgravity operations, because of the high content of possibly pathogenic bacteria contained in the stool and because of the potential of injury to crewmembers and hardware that could result from such dissemination. The collection capacity accounts for the average healthy adult maximum output during a single event. From a waste management system standpoint, normal feces should not be accounted for on days when crewmembers are afflicted with diarrhea.

3.5.3.2.4 Diarrhea per Event

[HS6020] The system shall provide collection and containment of 1.5 L of diarrheal discharge in a single event.

Rationale: Fecal waste collection must be performed in a manner that minimizes possible escape of fecal contents into the habitable vehicle during microgravity operations because of the high content of possibly pathogenic bacteria contained in the stool and because of the potential of injury to crewmembers and hardware that could result from such dissemination. The fecal discharge due to

Revision: E	Document No: CxP 70024
Release Date: 11/19/10	Page: 110 of 503
Title: Constellation Program Human-Systems Integration Requirements	

gastrointestinal illness (diarrhea) occurs at an increased frequency and volume but is also variable and unpredictable. The volume for a single discharge is to accommodate diarrhea caused by likely pathogens such as rotavirus and enterotoxigenic E coli. The volume 1.5 L is based on evaluation of individuals afflicted with pathogenic diarrhea, as found in medical literature, based on most likely maximal discharge in afflicted individuals. The volume 1.5 L is a maximum output and the average output will be 0.5 L. From a waste management system standpoint, normal feces should not be accounted for on days when crewmembers are afflicted with diarrhea.

3.5.3.2.5 Diarrheal Events per Crewmember

[HS6020D] The system shall provide for the collection and containment of diarrheal events as indicated in HS6020D, table Diarrhea Collection and Containment.

TABLE 3.5.3.2.5-1 - DIARRHEA COLLECTION AND CONTAINMENT

Mission	Design-to Number of Diarrhea Events Per Crewmember Per Mission	Total Volume of Diarrhea Per Crewmember Per Mission
Orion to or from ISS (3 days)	4	2 L
Orion Lunar Mission (16 days)	8	4 L
Altair (Sortie) (7days)	6	3 L

Rationale: These design-to "number of events" and "total volume" diarrhea values represent more common and likely diarrhea causes, such as diet, medication, and gastrointestinal reactivity factors, or a low pathogenicity microbial event, all of which are unlikely to affect all crewmembers.

Fecal discharge due to gastrointestinal illness (diarrhea) occurs at an increased frequency but is also variable and unpredictable. It is assumed that there is an average volume of 0.5 L per event. The World Health Organization (WHO) criteria for acute diarrhea is > 3 events of unformed stool within 24 hours, and since diarrhea of viral etiology typically lasts for a period of 1 to 3 days, one case of diarrhea would be expected to result in approximately 2 to 6 total liters of diarrhea. After the second day of the diarrheal event with evacuation of the colon, fecal matter output per crewmember would be expected to be significantly reduced for the subsequent 2 days (less than 100 cc/day), and then fecal volume would be expected to return to normal. From a waste management system standpoint, normal feces should not be accounted for on days when crewmembers are afflicted with diarrhea.

In order to properly accommodate diarrheal events, the number of events must be specified. The Orion Lunar mission (approximately 16 days), relative to the Orion ISS mission (approximately 3 days), has a higher number of events and

Revision: E	Document No: CxP 70024
Release Date: 11/19/10	Page: 111 of 503
Title: Constellation Program Human-Systems Integration Requirements	

volume due to the longer duration of this mission, increasing the likelihood of diarrheal occurrence. Altair (sortie) values are based on the assumption of a 7 day surface stay. These design-to numbers represent an averaging of number and volume of diarrhea event occurrence and severity per crewmember based on source exposure likelihood. These values assume that the likelihood of a maximal case diarrheal event affecting all crewmembers is extremely low. Values will not correspond directly with the length of mission due to the fact that once a diarrheal case occurs, multiple events are highly likely. Minimal collection of diarrhea must be accounted for on every mission, with higher chances of more severe, or multiple cases on longer missions. Based on available in-flight data as of July 2009, the likelihood of diarrhea is approximately 1.21 cases per person-year.

3.5.3.3 Urine

3.5.3.3.1 Urine Collection

[HS6021] The system shall provide a crew interface that captures urine and controls splash.

Rationale: Urine output may be slightly greater or lower in various phases of the mission associated with g- transitions and fluid intake levels. The urinary collection system must be capable of collecting all of the crewmember's output in succession, with an average void varying from 100 to 500 mL. Rarely, a single void might be as much as 1 L, so the equipment should be able to accommodate this maximum. The rate of urinary delivery into the system from the body will vary by gender (greater for females because of lower urethral resistance) but averages 10 to 35 mL/s. Maximum flow rate with abdominal straining in a female may be as high as 50 mL/s for a few seconds. The voided urine must be contained by the stowage and disposal hardware to prevent inadvertent discharge in the cabin that could result in injury to crewmember's mucous membranes or equipment.

3.5.3.3.2 Urine Wipes

[HS6022] The system shall provide the collection and containment of consumable wipe materials for urine.

Rationale: Urine output may be slightly greater or lower in various phases of the mission associated with g- transitions and fluid intake levels. The urinary collection system must be capable of collecting all of the crewmember's output in succession, with an average void varying from 100 to 500 mL. Rarely, a single void might be as much as 1 L, so the equipment should be able to accommodate this maximum. The rate of urinary delivery into the system from the body will vary by gender (greater for females because of lower urethral resistance) but averages 10 to 35 mL/s. Maximum flow rate with abdominal straining in a female may be as high as 50 mL/s for a few seconds. The voided urine must be

Revision: E	Document No: CxP 70024
Release Date: 11/19/10	Page: 112 of 503
Title: Constellation Program Human-Systems Integration Requirements	

contained by the stowage and disposal hardware to prevent inadvertent discharge in the cabin that could result in injury to crewmembers' mucous membranes or equipment. Historically, on the Shuttle, a total of 20 wipes per crewmember per day (including urine and feces uses) were flown for waste management. The Shuttle wipes packages hold 40 wipes and have the following dimensions: 20.3cm x 10.9cm x 4.6cm (8.0" x 4.3" x 1.8").

3.5.3.3.3 Urine per Crewmember

[HS6023] The system shall collect, and isolate from the crew environment, a maximum urine output volume of:

$$V_U = 3 + 2t$$

liters per crewmember, where t is the mission length in days.

Rationale: Urine production on the first day after launch (i.e., flight day "0") is 3 L per crewmember. Urine output may be slightly greater or lower in various phases of the mission associated with g- transitions and fluid intake levels. The urinary collection system must be capable of collecting all of the crewmember's output in succession, with an average void varying from 100 to 500 mL. Rarely, a single void might be as much as 1 L, so the equipment should be able to accommodate this maximum. The rate of urinary delivery into the system from the body will vary by gender (greater for females because of lower urethral resistance) but averages 10 to 35 mL/s. Maximum flow rate with abdominal straining in a female may be as high as 50 mL/s for a few seconds. The voided urine must be isolated from the crew environment by the stowage and disposal hardware to prevent inadvertent discharge in the cabin that could result in injury to crewmember's mucous membranes or equipment. This requirement is not intended to preclude venting of collected urine.

3.5.3.3.4 Urine per Hour

[HS6024] The system shall provide collection and isolation from the crew environment of 1 L of urine per crewmember per hour.

Rationale: Urine output may be slightly greater or lower in various phases of the mission associated with g- transitions and fluid intake levels. The urinary collection system must be capable of collecting all of the crewmember's output in succession, with an average void varying from 100 to 500 mL. Rarely, a single void might be as much as 1 L, so the equipment should be able to accommodate this maximum. The rate of urinary delivery into the system from the body will vary by gender (greater for females because of lower urethral resistance) but averages 10 to 35 mL/s. Maximum flow-rate with abdominal straining in a female may be as high as 50 mL/s for a few seconds. The voided urine must be isolated from the crew environment by the stowage and disposal hardware to prevent inadvertent discharge in the cabin that could result in injury to crewmember's

Revision: E	Document No: CxP 70024
Release Date: 11/19/10	Page: 113 of 503
Title: Constellation Program Human-Systems Integration Requirements	

mucous membranes or equipment. This requirement is not intended to preclude venting of collected urine.

3.5.3.3.5 Urine per Day

[HS6025B] The system shall provide collection and isolation from the crew environment for an average of 6 urinations per crewmember per day.

Rationale: The number of urinations per day is individually variable with the assumed average of six times per day. Urine output may be slightly greater or lower in various phases of the mission associated with g- transitions and fluid intake levels. The urinary collection system must be capable of collecting all of the crewmember's output in succession, with an average void varying from 100 to 500 mL. Rarely, a single void might be as much as 1 L, so the equipment should be able to accommodate this maximum. The rate of urinary delivery into the system from the body will vary by gender (greater for females because of lower urethral resistance) but averages 10 to 35 mL/s. Maximum flow-rate with abdominal straining in a female may be as high as 50 mL/s for a few seconds. The voided urine must be isolated from the crew environment by the stowage and disposal hardware to prevent inadvertent discharge in the cabin that could result in injury to crewmember's mucous membranes or equipment. This requirement is not intended to preclude venting of collected urine.

3.5.3.3.6 Urine Rate

[HS6025] The system shall provide collection and isolation from the crew environment for urinary discharges of up to 1 L in a single micturition, at a maximum delivery of 50 mL/s.

Rationale: Urine output may be slightly greater or lower in various phases of the mission associated with g- transitions and fluid intake levels. The urinary collection system must be capable of collecting all of the crewmember's output in succession, with an average void varying from 100 to 500 mL. Rarely, a single void might be as much as 1 L, so the equipment should be able to accommodate this maximum. The rate of urinary delivery into the system from the body will vary by gender (greater for females because of lower urethral resistance) but averages 10 to 35 mL/s. Maximum flow-rate with abdominal straining in a female may be as high as 50 mL/s for a few seconds. The voided urine must be isolated from the crew environment by the stowage and disposal hardware to prevent inadvertent discharge in the cabin that could result in injury to crewmember's mucous membranes or equipment. This requirement is not intended to preclude venting of collected urine.

Revision: E	Document No: CxP 70024
Release Date: 11/19/10	Page: 114 of 503
Title: Constellation Program Human-Systems Integration Requirements	

3.5.3.4 Simultaneous Defecation and Urination

3.5.3.4.1 Simultaneous Defecation and Urination

[HS6014] The system shall allow a crewmember to defecate and urinate simultaneously without completely removing lower clothing.

Rationale: This capability will ensure that there is no accidental discharge of one or both waste components into the habitable volume, as many individuals are incapable of relaxing the gastrointestinal control sphincter without relaxing the urinary voluntary control sphincter, and vice versa. To minimize impact to crew operations, waste elimination needs to be accomplished with minimal crew overhead, e.g., without completely removing clothing.

3.5.3.5 Odor Control

3.5.3.5.1 Waste Management Odor Control

[HS6029] The system shall provide odor control for the waste management equipment.

Rationale: Uncontrolled waste-associated odors can have an adverse effect on crew performance and can exacerbate pre-existing symptoms of Space Motion Sickness.

3.5.3.5.2 Auditory and Olfactory Privacy

[HS6069] The system should provide auditory and olfactory privacy for body waste management.

Rationale: In a small vehicle, provisions for privacy during waste management allow things such as videoconferences to proceed uninterrupted.

3.5.3.6 Waste Management Stowage

3.5.3.6.1 Waste Management Stowage

[HS6030] The system shall provide waste management supplies at a location that is accessible to the crewmember using the waste management station.

Rationale: Waste management wipes must be accessible where they are needed, in or immediately adjacent to the waste management system within reach of the crewmember.

3.5.3.7 Waste Management Trash

3.5.3.7.1 Waste Management Trash

[HS6031] The system should provide readily accessible trash collection, with odor control, for waste management items.

Rationale: Waste management items that cannot be collected and contained with human waste must be disposed of immediately after use and within reach of

Revision: E	Document No: CxP 70024
Release Date: 11/19/10	Page: 115 of 503
Title: Constellation Program Human-Systems Integration Requirements	

the crewmember without egressing the waste management restraint system and without the need to access closed compartments.

3.5.4 Exercise

3.5.4.1 Exercise Capability

3.5.4.1.1 Exercise Capability

[HS6032] The system shall provide the capability for aerobic and resistive exercise training for 30 continuous minutes each day per crewmember for missions greater than 8 days.

Rationale: An exercise capability is not required on Orion missions to the ISS or for missions with total durations of less than 8 days. Exercise is required on Lunar missions greater than 8 total days to maintain crew cardiovascular fitness (to aid in ambulation during g- transitions and to minimize fatigue), to maintain muscle mass and strength/endurance (to complete mission tasks such as EVA walk-back and contingency response capability,) and for recovery from strenuous tasks, confined postures, and to rehabilitate minor muscle injuries. Per the Apollo crew participating in the June 2006 Apollo Medical Summit (Houston, TX) and recommendation from the 2005 Musculoskeletal Summit, exercise should be commenced as early as possible during the mission and continue throughout all mission phases. Exercise will not be required on launch day, landing day, days that include ascent to and descent from the lunar surface, and on contingency, non-wave off days. Given these exclusions, it is expected that exercise will be performed in the Orion on up to 11 days of a maximum 18-day Orion stay. Expected CO₂, heat, and water output can be found in Appendix E, table Crew Induced Metabolic Loads for a Standard Mission Day With Exercise.

3.5.4.2 Exercise Operational Envelope

3.5.4.2.1 Exercise Operational Envelope

[HS6035] The system shall provide 2.23 m x 1.01 m x 1.31 m (7.3 ft x 3.3 ft x 4.3 ft) of operational envelope for completion of exercise during non-dynamic mission phases when exercise is being conducted.

Rationale: The operational envelope is the greatest volume required by a crewmember to use an exercise device (not the deployed volume of the device) and is derived utilizing the HSIR Critical Anthropometry Dimensions, Appendix B, table Vehicle Design Critical Anthropometry Dimensions for maximum stature while standing and maximum sitting height while using a rower/cycle ergometer device (no arms overhead).

Revision: E	Document No: CxP 70024
Release Date: 11/19/10	Page: 116 of 503
Title: Constellation Program Human-Systems Integration Requirements	

3.5.4.3 Environmental Loads during Exercise

3.5.4.3.1 Thermal Environment During Exercise

[HS6036] The system shall maintain the vehicle's thermal environment, as defined in HS3036 and HS3037 during crew induced thermal loading as defined in Appendix E, table Crew Induced Metabolic Loads for a Standard Mission Day With Exercise.

Rationale: Each crewmember can be expected to generate these heat loads during a mission. Further rationale is found in Appendix E, table Crew Induced Metabolic Loads for a Standard Mission Day With Exercise legend and its associated Appendix E. This requirement can be met by integrated systems with the details of each system's responsibility in individual system SRDs and in IRDs.

3.5.4.3.2 Oxygen Levels During Exercise

[HS6073] The system shall provide O₂ for crew consumption as defined in Appendix E, table Crew Induced Metabolic Loads for a Standard Mission Day With Exercise.

Rationale: Each crewmember can be expected to consume these O₂ quantities during a mission. Further rationale is found in the table legend.

3.5.4.3.3 Carbon Dioxide Levels During Exercise

[HS6037] The system shall maintain the vehicle's atmospheric gases, as defined in HS3005, during crew generated CO₂ loading as defined in Appendix E, table Crew Induced Metabolic Loads for a Standard Mission Day With Exercise.

Rationale: Each crewmember can be expected to generate these CO₂ loads during a mission. Further rationale is found in the legend of Appendix E, table Crew Induced Metabolic Loads for a Standard Mission Day With Exercise.

3.5.4.3.4 Relative Humidity During Exercise

[HS6038] The system shall maintain the vehicle's relative humidity, as defined in HS3046, during crew generated water vapor loading as defined in Appendix E, table Crew Induced Metabolic Loads for a Standard Day With Exercise.

Rationale: Each crewmember can be expected to generate these water vapor loads during a mission. Further rationale is found in the legend of Appendix E, table Crew Induced Metabolic Loads for a Standard Mission Day With Exercise.

3.5.5 Space Medicine

3.5.5.1 Data and Communications

3.5.5.1.1 Private Voice

[HS6075] The system shall provide two-way private voice communication with Ground Operations during pre-launch activities and with Mission Systems during inflight activities, except during ascent, entry, and post-landing.

Revision: E	Document No: CxP 70024
Release Date: 11/19/10	Page: 117 of 503
Title: Constellation Program Human-Systems Integration Requirements	

Rationale: Private voice communication will assure that the exchange of medical information, therapeutic confidences, and psychological conferences between the crew and the medical operations support team, as well as family conferences, will remain private.

3.5.5.1.2 Private Video

[HS6076] The system shall provide private video capability with Mission Systems during all mission phases except ascent, entry, and post-landing.

Rationale: Private video communication will assure that the exchange of medical information, therapeutic confidences, and psychological conferences between the crew and the medical operations support team, as well as family conferences, will remain private. This does not imply a private location in the vehicle.

3.5.5.1.3 Communication Capabilities

[HS6097] The system shall provide audio, text, and video uplink and downlink capabilities with a delivery delay of less than 4 hours.

Rationale: The behavioral health and performance countermeasures are necessary for successful adaptation to living and working in an isolated and confined environment, maintaining individual behavioral health and performance, and maintaining performance and functioning of the entire crew as a unit. To be effective, countermeasures must be available that are consistent with individual and team needs, mission duration, and crew duty periods. The audio, text, video, and e-mail uplink and downlink capabilities will be used to uplink news (audio/video and written summaries), recreational audio, and video materials, as well as maintain contact with family, friends, and other individuals or organizations.

3.5.5.1.4 Personalized In-Flight Updates

[HS6099] The system shall provide for in-flight updates of the personalized on-board databases.

Rationale: The behavioral health and performance countermeasures are necessary for successful adaptation to living and working in an isolated and confined environment, maintaining individual behavioral health and performance, and maintaining performance and functioning of the entire crew as a unit. To be effective, countermeasures must be available that are consistent with individual and team needs, mission duration, and crew duty periods. Periodic updates to the personalized on-board databases are necessary for the crewmember to aid in psychological adaptation by providing similar off-duty activities to those performed at home.

Revision: E	Document No: CxP 70024
Release Date: 11/19/10	Page: 118 of 503
Title: Constellation Program Human-Systems Integration Requirements	

3.5.5.1.5 Biomedical Data

[HS6077] The system shall collect biomedical data.

Rationale: Biomedical data transmission to the ground Mission Control Center (MCC) will be required for medical evaluation of crewmembers, including during suited operation; therefore, biomedical data will need to be collected.

3.5.5.1.6 Biomedical Relay

[HS6078] The system shall relay biomedical telemetry to Mission Systems.

Rationale: Ground medical support during nominal and contingency circumstances, including medical events and during EVA, as well as during unrecoverable vehicle pressure loss is necessary to ensure the health and safety of the crewmember(s) and to provide appropriate information to the Flight Director. Supervision of the biomedical data will maximize crew resource management for the event and minimize risk for the crewmember(s).

3.5.5.1.7 Biomedical Display

[HS6079] The system shall display biomedical data to the crew.

Rationale: Real-time biomedical data need to be displayed to the crew so the Crew Medical Officer(s) (CMO) can make decisions regarding the health status of the crew. In the event of a medical emergency, the CMO requires data display to determine the appropriate course of treatment. This becomes particularly critical during breaks in communication when no bio-medical data are being transmitted to flight surgeons in the Mission Control Center (MCC).

3.5.5.2 Orthostatic Protection

3.5.5.2.1 Orthostatic Protection

[HS6082] The system shall provide crewmember orthostatic protection for return into a 1-g environment.

Rationale: Orthostatic protection is needed to minimize operational impacts. Operational impacts can include loss of consciousness, inability to operate controls, and inability to egress the vehicle without assistance and thus could jeopardize the success of the re-entry and landing of the vehicle and the safety of the crewmembers. Methods that have been successfully used to prevent orthostasis include fluid/salt loading regimens to maintain hydration, constrictive leg garments to prevent blood pooling, active cooling to maintain crew comfort, and recumbent crewmember seating to improve cerebral blood flow in 1 g. Furthermore, research studies of pharmacologic measures are also promising.

Revision: E	Document No: CxP 70024
Release Date: 11/19/10	Page: 119 of 503
Title: Constellation Program Human-Systems Integration Requirements	

3.5.5.3 Medical Area and Capability

3.5.5.3.1 Medical Care Provider Access

[HS6083] The system shall provide a designated medical area with medical care provider access to the ill/injured crewmember.

Rationale: The medical care provider may need to complete tasks in close proximity to the ill/injured crewmember. This includes tasks such as providing positive pressure ventilation. This applies to all mission phases except Earth launch and lunar descent.

3.5.5.3.2 Patient Electrical Isolation

[HS6084] The system shall provide a designated medical area with patient electrical isolation.

Rationale: To protect both avionics of the vehicle and other crewmembers from inadvertent electrical shock, the patient will need to be electrically isolated from the vehicle in the event defibrillation is required.

3.5.5.3.3 Access to Medical Equipment

[HS6085] The system shall provide a designated medical area with access for medical equipment to patient interfaces.

Rationale: The medical provider, or caregiver, must be able to attach medical equipment appropriately to the ill/injured crewmember within the designated area. The term "patient interface" is used to denote any part of the patient that must come in contact with the medical equipment. For example, there must be enough volume in the designated area for a pulse oximeter probe to be attached to a patient's finger to obtain pulse oximetry data.

3.5.5.3.4 Access to Deployed Medical Kits

[HS6086] The system shall provide a designated medical area with access to deployed medical kits within the reach of medical care provider.

Rationale: In order for the medical care provider to effectively attend to an ill/injured crewmember, the provider must be able to reach the equipment and supplies in the deployed medical kits. This requirement is to ensure that the provider can obtain equipment and supplies in a time efficient manner to meet the needs of an ill/injured crewmember.

3.5.5.3.5 Medical Care Capabilities

[HS6101] The system shall provide the medical care capabilities specified in HS6101, table Medical Care Capabilities.

Revision: E	Document No: CxP 70024
Release Date: 11/19/10	Page: 120 of 503
Title: Constellation Program Human-Systems Integration Requirements	

TABLE 3.5.5.3.5-1 - MEDICAL CARE CAPABILITIES

Level of Care	Mission	Capability
I	LEO < 8 days	Space Motion Sickness, Basic Life Support, First Aid, Private Audio, Anaphylaxis Response
II	LEO < 30 day	Level I + Clinical Diagnostics, Ambulatory Care, Private Video, Private Telemedicine
III	Beyond LEO < 30 day	Level II + Limited Advanced Life Support, Trauma Care, Limited Dental Care
IV	Lunar > 30 day	Level III + Medical Imaging, Sustainable Advanced Life Support, Limited Surgical, Dental Care
V	Mars Expedition	Level IV Autonomous Advanced Life Support and Ambulatory Care, Basic Surgical Care

Rationale: NASA-STD-3001, Space Flight Human Systems Standard, Volume 1: Crew Health include definitions of the levels of medical care required to reduce the risk that exploration missions are impacted by crew medical issues, and that long-term astronaut health risks are managed within acceptable limits. The levels of care and associated appendices define the healthcare, crew protection, and maintenance capability required to support the crew as appropriate for the specific mission destination and duration, as well as the associated vehicular constraints. As mission duration and complexity increase, the capability required to prevent and manage medical contingencies correspondingly increases. Very short duration missions (i.e., transfer missions, such as lunar ascent vehicle to Orion [<24 hours] or Orion to ISS or Mars Transit Vehicle) even if outside Low Earth Orbit (LEO) will be considered as Level I capability medical requirements. The ability to provide the designated level of care applies to all flight phases, including during pressurized suited operations.

3.5.5.4 Crew Sleep Accommodations

3.5.5.4.1 Crew Sleep Accommodations

[HS6104] The system shall provide accommodations for crew sleep.

Rationale: The sleep accommodations requirement ensures that the crew is able to assume a proper configuration to obtain adequate sleep/rest for performance of duties. At a minimum, sleep accommodations include a restrained sleeping position that allows for both full body extension as well as for bringing both knees up to the chest and allows for implementation of HSIR sleep requirements (HS3106, HS3079, and HS5035).

Revision: E	Document No: CxP 70024
Release Date: 11/19/10	Page: 121 of 503
Title: Constellation Program Human-Systems Integration Requirements	

3.5.6 Stowage

3.5.6.1 Stowage Nominal Operation

[HS6044] The system should provide defined stowage locations that do not interfere with normal crew operations.

Rationale: This requirement is intended to prevent the stowage system from interfering with normal operations such as translation and vehicle control. A “should” is used because constraints on the placement of other items may prevent the design from completely satisfying this requirement.

3.5.6.2 Stowage Location

[HS6046] The system should provide stowage for equipment and supplies near their intended point of use.

Rationale: To maintain a high level of efficiency in crew operations, it is important to locate items within easy reach of their point of use or consumption. A “should” is used because constraints on the placement of other items may prevent the design from completely satisfying this requirement.

3.5.6.3 Stowage Arrangement

[HS6047] Stowed items should be arranged in functional groups.

Rationale: To promote efficient retrieval of stowed items, items used in the same procedure are best stowed together. To promote crew comprehension of the stowage plan, similar items are best stowed together. A “should” is used because (i) the previous two notions may contradict one another, and (ii) constraints on the placement of other items may prevent the design from completely satisfying this requirement.

3.5.6.4 Stowage Reconfiguration

[HS6049] Stowage should be reconfigurable during the mission.

Rationale: Any stowage system must be flexible enough to accommodate the changes and evolution expected in the stowage plan over the length of a mission. For example, (i) as food is consumed during a mission, food stowage may need to be reallocated for trash, and (ii) during lunar return, lunar samples might be stowed in space originally allocated for water storage.

3.5.6.5 Stowage Restraints

[HS6050] The system shall provide restraints for stowed items sufficient to prevent them from coming loose under the expected acceleration and vibration environments.

Rationale: Stowed items must be restrained so that they are not free to move during vehicle motion, under the influence of internal air movement, or after inadvertent contact.

Revision: E	Document No: CxP 70024
Release Date: 11/19/10	Page: 122 of 503
Title: Constellation Program Human-Systems Integration Requirements	

3.5.6.6 Stowage Equipment Cover Restraint

[HS6106] The system shall provide a means to secure, in the open position, stowage and containment equipment covers that cannot be fully removed.

Rationale: In microgravity, attached covers must be restrained to allow for unobstructed access to stowage or containment volumes. Crewmembers should be able to access the stowage container contents with both hands, and should not be required to hold covers open manually. Covers must be secured such that they do not slam shut or swing open under normal vehicle accelerations and vibrations. Mechanical restraints may include latches, clips, snaps, velcro, or other similar features.

3.5.6.7 Stowage Hand Operation

[HS6051] Stowage provisions shall be operable without the use of tools.

Rationale: To maximize the use of crew time, the stowage system must permit crew access and reconfiguration without the use of tools.

3.5.6.8 Stowage Commonality

[HS6052] Stowage provisions should be common throughout the vehicle.

Rationale: For example, stowage items such as ISS Cargo Transfer Bags (CTBs) should be interchangeable so that each bag is usable in each stowage location. Lids, covers, and dividers should be interchangeable. Stowage container sizes that are whole multiples of the smallest container size permit efficient reconfiguration of stowage. This requirement is a "should" because, for example, a stowage container designed for a specific nook within the vehicle or to hold a specific device under ascent loading will not be interchangeable with others.

3.5.6.9 Stowage Compatibility with Inventory Management

[HS6053] The stowage system shall be compatible with the Program's system for inventory management.

Rationale: ISS experience has shown that inventory management – the knowledge of the quantity and location of each type of supply – is crucial for mission planning and maintaining crew productivity. The stowage system should help the crew and Mission Operations gather this stowage information, for example by using bar-coded and clearly labeled stowage locations.

3.5.7 Trash Management

3.5.7.1 Trash Management Nominal Operations

[HS6054] The system should allocate space for trash stowage that does not interfere with normal crew operations.

Revision: E	Document No: CxP 70024
Release Date: 11/19/10	Page: 123 of 503
Title: Constellation Program Human-Systems Integration Requirements	

Rationale: This requirement is intended to prevent the trash system from interfering with normal operations such as translation and vehicle control. A “should” is used because constraints on the placement of other items may prevent the design from completely satisfying this requirement.

3.5.7.2 Trash Management Odor Control

[HS6056] The trash management system shall provide odor control for wet trash.

Rationale: Uncontrolled odors can have an adverse effect on crew performance, and can exacerbate pre-existing symptoms of Space Adaptation Syndrome (SAS).

3.5.7.3 Trash Management Contamination Control

[HS6057] The trash management system shall prevent the release of trash into the habitable environment.

Rationale: Many components of trash act as nutrient sources for microorganisms and quickly increase their concentrations. These microorganisms can include medically significant organisms, which could negatively impact crew health and performance. Historically, prevention of the release of microorganisms has been accomplished through layers of containment and addition of trash to the system using methods that do not promote aerosolization of the contents.

3.5.7.4 Trash Management Hazard Containment

[HS6058] The trash management system shall prevent the escape of its contents including crew-generated biological wastes.

Rationale: If not properly contained, contents could damage equipment, injure crewmembers, and transmit disease. Biological waste, including suited feces/urine collection devices, vomit, and feminine hygiene products, can also cause injury and transmit disease.

3.6 CREW INTERFACES

A vehicle's crew interface is any part of that vehicle through which information is transferred between the crew and the vehicle, whether by sight, sound, or touch. Usable, well-designed crew interfaces are critical for crew safety and productivity, and minimize training requirements. This section provides requirements for crew-controlled processes and the design of crew interfaces for displays and controls. A display is anything that provides visual or auditory information to crewmembers (e.g., label, placard, tone, or display device). A display device is the hardware that displays information to crewmembers. A control is anything that accepts crewmember commands or inputs, whether hardware or software.

3.6.1 General

Revision: E	Document No: CxP 70024
Release Date: 11/19/10	Page: 124 of 503
Title: Constellation Program Human-Systems Integration Requirements	

3.6.1.1 Consistent Crew Interfaces

[HS7007] The system should provide crew interfaces that are consistent in appearance and operation across Constellation systems.

Rationale: The intent of this statement is to ensure as much commonality and consistency as possible across Constellation systems. This will facilitate learning and minimize interface-induced crew error.

3.6.1.2 Labeling

[HS7036] The system shall provide labels for crew interfaces in accordance with CxP 70152, Constellation Program Crew Interface Labeling Standard.

Rationale: Crew interface items must have identifiers (labels) to aid in crew training and error-free operation.

3.6.1.3 Nomenclature

[HS7079] Nomenclature related to on-orbit operations shall conform to the OpsNom Standards in CxP 70172-01, Constellation Program Data Architecture Specification, Volume 1: Naming and Identification Rules .

Rationale: It is imperative for ISS operation that all operations personnel, including all ground controllers and onboard crewmembers, communicate using common nomenclature that unambiguously and uniquely defines all hardware and software items that may be utilized, the methods by which these are used, and data concerning these items. This nomenclature must also be common among all operational products, including commands, procedures, displays, planning products, reference information, system handbooks, system briefs, mission rules, schematics, and payloads operations products. Labeling applicable only to ground-based (non-operational) functions may use other common technical terms.

3.6.1.4 Legibility

[HS7044] The system shall provide crew interfaces that are legible under nominal conditions.

Rationale: Legibility is important for the crew's timely and accurate processing of information. Legibility may vary depending on vehicle conditions (e.g., acceleration, vibration, and lighting) and must be accommodated. For example, during flight phases where high vibration is expected, relevant displays may need to be designed with this in mind (e.g. analog vs. digital displays, larger graphics and text).

Revision: E	Document No: CxP 70024
Release Date: 11/19/10	Page: 125 of 503
Title: Constellation Program Human-Systems Integration Requirements	

3.6.1.5 Language

[HS7064] Text shall be written in the American English language based on Webster's New World Dictionary of American English, and all acronyms and terms used shall be based on the Cx Common Glossary & Acronyms:

<https://ice.exploration.nasa.gov/confluence/display/CxCGA/Common+Glossary+and+Acronyms>.

Rationale: The intent of this requirement is to ensure as much commonality and consistency as possible in written text (i.e., language and spelling) across vehicle subsystems and across Constellation systems. This will facilitate learning and minimize interface-induced crew error.

3.6.1.6 Use of Color

[HS7065A] The system shall provide an additional cue to convey crew interface information when color is used to convey meaning.

Rationale: Redundant coding is required to accommodate the variability in people's capability to see color under different lighting conditions and to increase the saliency of identification markings. Redundant cues can include language-based cues (text labels and speech messages), as well as iconic cues presented via the visual, auditory or haptic modalities.

3.6.2 Crew Performance

3.6.2.1 Crew Interface Usability

3.6.2.1.1 Crew Interface Usability

[HS7066] The system shall provide crew interfaces that result in a maximum of 5% erroneous task steps per participant, where each erroneous task step is committed by 10% or fewer participants.

Rationale: For optimal safety and productivity, software and hardware crew interfaces must support crew performance with minimal errors. Errors may lead to significant timeline impacts or task failure; therefore errors can cause loss of efficiency, effectiveness, and satisfaction. An erroneous task step is defined as a task step with one or more design-induced errors. A design-induced error is an intentional action that does not reach its intended goal due to design issues. Examples of errors that may be design-induced include: missed or incorrect inputs or selections, display navigation errors, errors due to inadequate hardware component design, errors due to lack of system feedback to user inputs, errors due to design inconsistency or unfamiliar terminology, and inability to complete a task step. Recoverable design-induced errors still negatively impact crew performance in terms of time and satisfaction; thus, they should be included in error calculations. Unintentional errors that are related to human reliability are not covered by this requirement.

Revision: E	Document No: CxP 70024
Release Date: 11/19/10	Page: 126 of 503
Title: Constellation Program Human-Systems Integration Requirements	

3.6.2.2 Crew Cognitive Workload

3.6.2.2.1 Workload Measure: Nominal

[HS7080] The system shall provide crew interfaces that together with nominal crew tasks result in Bedford Workload Scale ratings of 3 or less.

Rationale: The workload measurement requirement enables standardized assessment of whether temporal, spatial, cognitive, and perceptual aspects of tasks and the crew interfaces for these tasks are designed and implemented to support each other. Application of workload measurement for crew interface and task designs in conjunction with other performance measures (such as error rates) helps assure safe, successful, and efficient system operations by the crew. Workload levels may be modulated (raised or lowered) through the combination of user-interface design and task design (e.g., task simplification, subtask combination and sequencing, and the distribution of tasks among multiple crewmembers and between crew and automation).

3.6.2.2.2 Workload Measure: Off-Nominal

[HS7080A] The system shall provide crew interfaces that together with off-nominal crew tasks result in a Bedford Workload Scale rating of 6 or less.

Rationale: The workload measurement requirement enables standardized assessment of whether temporal, spatial, cognitive, perceptual, and physical aspects of tasks and the crew interfaces for these tasks are designed and implemented to support each other. Application of workload measurement for crew interface and task designs in conjunction with other performance measures (such as error rates) helps assure safe, successful, and efficient system operations by the crew. Workload levels may be modulated (raised or lowered) through the combination of user-interface design and task design (e.g., task simplification, subtask combination and sequencing, and the distribution of tasks among multiple crewmembers and between crew and automation).

3.6.2.3 Handling Qualities

3.6.2.3.1 Handling Qualities for Manual Control – Level 1

[HS7003] The system shall exhibit Level 1 handling qualities (handling quality ratings of 1, 2, or 3) as defined by Cooper-Harper Scale during manual control of the spacecraft's fight path and attitude for selected manual control scenarios.

Rationale: The intent of this requirement is to ensure that the crew is able to successfully control the vehicle or vehicle systems requiring manual operation during manual control. Selected manual control scenarios that must meet Level 1 handling qualities will be defined via review of potential manual control scenarios and associated manual control modes, with required manual control scenarios scoped with Program agreement. A scenario includes one or more

Revision: E	Document No: CxP 70024
Release Date: 11/19/10	Page: 127 of 503
Title: Constellation Program Human-Systems Integration Requirements	

handling quality related vehicle control tasks performed during a flight phase under specified conditions. A handling quality related task is defined as the manual control capability that is being rated with the Cooper-Harper Rating Scale. Each task within a scenario is rated separately and must meet Level 1 handling qualities (handling quality ratings of 1, 2 or 3). Reference NASA TND-5153 for the Cooper-Harper Rating Scale.

3.6.2.3.2 Handling Qualities for Manual Control – Level 2

[HS7004] The system shall exhibit at least Level 2 handling qualities (handling quality ratings of 1, 2, 3, 4, 5, or 6) on the Cooper-Harper Ratings Scale during manual control of the spacecraft's flight path and attitude for selected manual control scenarios where the degradation of flight controls or the occurrence of severe and multiple failures preclude Level 1 ratings.

Rationale: Handling quality ratings worse than Level 1 are acceptable for special case manual control scenarios where the degradation of flight controls or the occurrence of severe and multiple failures preclude Level 1 ratings. These selected scenarios will be pre-declared as Level 2 appropriate scenarios a priori based on identified degradation of flight controls or severe and multiple failures, and not merely as the result of a failure to meet Level 1. A list and defined scope of special case scenarios will be created based upon a subset of identified manual control scenarios. The applicability and implementation of these special cases will be scoped with Program agreement and documented through the creation of flight rules.

3.6.3 Display and Control Layout

3.6.3.1 Viewing Requirements

3.6.3.1.1 Field of View

[HS7010] The system shall locate displays and controls, which are viewed for operation, within the field of view of the crew using those displays and controls to perform their tasks.

Rationale: Displays and controls must be visible to the person using them during all phases of flight and under all conditions in which they are required. The term "perform their task" is meant to include both monitoring and operating.

3.6.3.1.2 Two-Crew Operations

[HS7010A] The system shall locate displays and controls such that two operators can view each other's operations for functions that are critical.

Rationale: This requirement is intended to facilitate a two-crew operations concept, which provides redundancy in cockpit decision-making. In the two-crew operations concept, the actions of the crewmember performing the task can be seen and verified by the other crewmember. As a counter-example, many

Revision: E	Document No: CxP 70024
Release Date: 11/19/10	Page: 128 of 503
Title: Constellation Program Human-Systems Integration Requirements	

Shuttle electrical and hydraulic controls can only be seen or operated by the pilot crewmember during the critical ascent phase. This requirement is not intended to override the requirement that the vehicle be operable by a single crewmember.

3.6.3.1.3 Viewing Critical Displays and Controls

[HS7018] The system should locate critical displays and controls near the center of the crew's field of view.

Rationale: The operator needs to be able to quickly visually locate critical displays and controls in order to address problems. This requirement applies to the crew during all operations, including ground operations of the emergency escape system.

3.6.3.1.4 Viewing Frequently Used Displays and Controls

[HS7018A] The system should locate frequently used displays and controls near the center of the operator's field of view.

Rationale: The operator needs to be able to quickly visually locate critical displays and controls in order to address problems. This requirement applies to the crew during all operations, including ground operations, of the emergency escape system.

3.6.3.1.5 Obscured Controls

[HS7067] Controls that are intended for out-of-view operation shall be spatially or tactually distinct from one another.

Rationale: When the crew inadvertently operates the wrong control, serious errors can result. Controls designed to be out-of-view while being operated must be spaced or shaped/textured such that the control can be identified with a pressurized gloved hand without line of sight. This would include controls for vehicle operation as well as other controls (e.g., seat positioning). It has been shown that human operators can use simple tactile coding to reliably distinguish between items.

3.6.3.1.6 Self-Illuminated Controls and Displays

[HS7082] The system shall provide self-illumination for displays and controls.

Rationale: Self-illumination (i.e., backlighting, trans-illumination, or integral lighting) of interfaces on a control panel provides contrast that is independent of external panel illumination. With an available dimming function, luminance can be adjusted for legibility in operational low or high ambient illumination conditions. The term panel is intended to include any push-button switches or data entry keyboards that may have self-illuminated markings.

Revision: E	Document No: CxP 70024
Release Date: 11/19/10	Page: 129 of 503
Title: Constellation Program Human-Systems Integration Requirements	

3.6.3.2 Reach Requirements

3.6.3.2.1 Functional Reach Envelope

[HS7019] The system shall locate controls within the functional reach envelope of the crew using those controls to perform their tasks.

Rationale: Controls have to be within the operator's reach envelope under all vehicle conditions (e.g., g-loads, vibration) and crew conditions (e.g., suited, seated, restrained, and unrestrained). Controls can include display devices such as touch screens.

3.6.3.2.2 Reach for Critical Controls

[HS7021] The system should centrally locate critical controls within the functional reach envelope.

Rationale: During the design process, trade-off of location of critical controls must be made; however, all controls will be required to be within the functional reach envelope of the crew. This requirement is intended to encourage the design of a layout that optimizes operations in the cockpit. A "should" is used here because optimization is an iterative process.

3.6.3.2.3 Reach for Frequently Used Controls

[HS7021A] The system should centrally locate frequently used controls within the functional reach envelope.

Rationale: During the design process, trade-off of locations of frequently used controls must be made; however, all controls will be required to be within the functional reach envelope of the crew. This requirement is intended to encourage the design of a layout that optimizes operations in the cockpit. A "should" is used here because optimization is an iterative process.

3.6.3.3 Display and Control Grouping

3.6.3.3.1 Functional Related Displays and Controls

[HS7022] The system should locate functionally related displays and controls near one another.

Rationale: This requirement is intended to encourage the design of a layout that optimizes operations in the cockpit. A "should" is used here because optimization is an iterative process.

3.6.3.3.2 Successive Operation of Displays and Controls

[HS7023] The system should locate displays and controls operated in quick succession near one another.

Revision: E	Document No: CxP 70024
Release Date: 11/19/10	Page: 130 of 503
Title: Constellation Program Human-Systems Integration Requirements	

Rationale: Rapid, error-free operation and quick comprehension of system status are all improved by well-designed co-location of related controls.

3.6.3.4 Control Spacing

3.6.3.4.1 Control Spacing For Suited Operations

[HS7024] The system shall space controls that are intended to be used by a pressurized suited crewmember such that they can be operated by a pressurized suited crewmember using those controls to perform their tasks.

Rationale: "Suited Operations" refers to the finite set of tasks that must be performed in a suit. Control layout must take into account the fact that pressurized suited operators cannot operate with the same precision and dexterity as lightly clothed crewmembers in expected conditions (e.g., g loads, vibration, and acceleration). Insufficient spacing may lead to inadvertent operation of an adjacent control.

3.6.3.4.2 Control Spacing for Unsuiting Operations

[HS7925] The system shall space controls that are intended to be used by an unsuited crewmember such that they can be operated by an unsuited crewmember using those controls to perform their tasks.

Rationale: Even lightly clothed crewmembers may have difficulty operating controls under expected conditions (e.g., g loads, vibration, and acceleration). Insufficient spacing may lead to inadvertent operation of an adjacent control.

3.6.4 Displays

3.6.4.1 Display Content

3.6.4.1.1 Task-Oriented Displays

[HS7059] The system shall provide task-oriented displays.

Rationale: "Task-oriented" displays include all the information required to complete a task and are designed specifically to help the crew perform key or frequently performed tasks. They consist of information from all of the different systems involved in the task. This allows the crew to quickly and efficiently perform a task as opposed to the crew having to use multiple system displays to perform a task. Examples of task displays are (i) a primary flight display, and (ii) a rendezvous display. Providing task-oriented displays allows for efficiency and ease of operation.

3.6.4.1.2 Subsystem-Oriented Displays

[HS7060] The system shall provide subsystem-oriented displays.

Rationale: "Subsystem" refers to an operationally specific component, such as the Environmental Control and Life Support Subsystem (ECLSS). "Subsystem-

Revision: E	Document No: CxP 70024
Release Date: 11/19/10	Page: 131 of 503
Title: Constellation Program Human-Systems Integration Requirements	

oriented" displays include all of the key information for a subsystem and are intended to help the crew monitor system health and status. Subsystem displays allow the operator to see the state of a single subsystem at a glance and aid in troubleshooting. They also allow the crew to perform tasks that were not originally envisioned. Providing subsystem-oriented displays allows for efficiency and ease of monitoring.

3.6.4.1.3 Viewing Simultaneous Task Information

[HS7060A] The system should provide the display area necessary to present all of the information required for a task simultaneously (i.e., without toggling among displays).

Rationale: Without sufficient display devices (e.g., screens), it will be difficult to present the crew with enough information to control a complex spacecraft.

3.6.4.1.4 Viewing Simultaneous Critical Task Information

[HS7070] The system shall provide display area required to simultaneously display critical task information to a single operator.

Rationale: Rapid response to mission-critical tasks will require simultaneous display of multiple sources of information. Without sufficient display devices (e.g., screens), it will be difficult to present the crew with enough information to control a complex spacecraft. Given a large display device the number of devices required might be one; with smaller display devices the number of devices may increase.

3.6.4.2 Display Hierarchy

3.6.4.2.1 Location within the Display Hierarchy

[HS7061] Displays shall provide the crew with the location of the current display within the display hierarchy.

Rationale: The crew must have situational awareness of where they are in the display hierarchy to maintain efficiency during navigation through the information management system.

3.6.4.2.2 Access within the Display Hierarchy

[HS7071] Displays should provide a method for the crew to have quick access to any level of the display hierarchy at any time.

Rationale: The crew should have quick access to any level of information to perform their task efficiently.

Revision: E	Document No: CxP 70024
Release Date: 11/19/10	Page: 132 of 503
Title: Constellation Program Human-Systems Integration Requirements	

3.6.4.3 System Feedback

3.6.4.3.1 State Change

[HS7072] Data across systems shall be updated for display within 1.0 second of a state change.

Rationale: The recommended response time of 1.0 second applies for user-system feedback (Nielsen, 1993). The intent of this requirement is to provide the crew with current information in the event the same display is called up on multiple display devices (i.e., all users need to see the same data) on different systems within a vehicle or habitat, between docked vehicles, or between vehicles in proximity operations (i.e., Orion and Altair).

3.6.4.3.2 Lost Data

[HS7072A] The system shall inform the crew when a displayed data parameter is unavailable.

Rationale: Feedback on data that are unavailable (i.e., lost or stale) is important to the crew for accurately weighing data during trouble-shooting and decision-making.

3.6.5 Hardware and Software Controls

3.6.5.1 Control Operation

3.6.5.1.1 Compatibility of Movement

[HS7063] Controls shall be designed such that the input direction is compatible with the resulting control response.

Rationale: Control-display compatibility is a widely-used design principle. It promotes quick learning of the vehicle's input-response characteristics, and error free operation of vehicle and other controls. "Controlled Object" refers to a display element, equipment component, or vehicle. Compatibility means that the control movement matches the expected results (e.g., control motion to the right is compatible with clockwise roll, right turn, and increase in volume).

3.6.5.1.2 Control Feedback

[HS7063A] The system shall provide a positive indication of crew-initiated control activation.

Rationale: A positive indication of control activation is used to acknowledge the system response to the control action. For example, a physical detent, an audible click, an integral light, or a switch position may be used to provide a positive indication of control activation.

Revision: E	Document No: CxP 70024
Release Date: 11/19/10	Page: 133 of 503
Title: Constellation Program Human-Systems Integration Requirements	

3.6.5.1.3 Protection against Inadvertent Activation

[HS7063B] The system should protect against inadvertent operation of controls.

Rationale: This requirement allows for the design to preclude inadvertent operation. For example, accidental activation by bumping can be prevented by the use of guards, covers, and physical separation from other controls. Accidental activation of commands using a computer display can be prevented with an "arm-fire" mechanism. This requirement is not intended to prevent operators from initially selecting the wrong control.

3.6.5.1.4 Protection for Flight Actuated Critical Controls

[HS7063C] The system shall protect against a single inadvertent actuation of mission critical and safety critical controls using a two-step process of two independent crew actions.

Rationale: A two-step process (e.g., arm-fire) is required to prevent an unintended control action that would result in either loss of mission or catastrophic hazards. This requirement is not intended to prevent the crew from initially selecting the wrong control.

3.6.5.1.5 Protection for Ground Actuated Critical Controls

[HS7083] The system shall protect against a single inadvertent actuation of mission and safety critical controls using a two-step process of two independent ground personnel actions.

Rationale: Inadvertent, human-initiated actions can result in loss of mission, loss of vehicle, loss of crew, or result in permanent disability to crew and ground personnel. A two-step process (e.g., arm-fire or select-send) is required to prevent an unintended control action that would result in loss of mission or a catastrophic hazard. This requirement is not intended to prevent operators from initially selecting the wrong control.

3.6.5.1.6 Coding for Emergency Controls

[HS7063D] The system shall provide coding for emergency controls that is distinguishable from non-emergency controls as specified in CxP 70152, Constellation Program Crew Interface Labeling Standard.

Rationale: Coding for emergency controls should allow the operator to distinguish them from other controls. It has been shown that operators react more quickly to simple coding such as colors and pictures than they do to written labels.

3.6.5.1.7 Restraints for Control Operation

[HS7063E] The system shall provide restraints for the crew for operation of controls during reduced gravity.

Revision: E	Document No: CxP 70024
Release Date: 11/19/10	Page: 134 of 503
Title: Constellation Program Human-Systems Integration Requirements	

Rationale: The crew must have a means of reacting to any required control input forces without letting those forces push him or her away from the control. This helps the crew maintain position and apply required control forces.

3.6.5.2 High-g Operations

3.6.5.2.1 Over 3 g

[HS7027] The system shall place controls used during accelerations above 3 g so that the operator can make control inputs via hand/wrist movements without reaching.

Rationale: Above 3 g, controls must be operable by a restrained, suited operator. In a study of reaches under G_x loading with veteran astronauts and aviators as suited subjects, there was a 6% reduction in forward reach displacement at 3 g, 18% at 4 g, and 32% at 5 g (Schafer & Bagian, Aviation, Space, and Environmental Medicine, 64: 979, 1993). Above 3 g, the accuracy of gross limb movements is compromised, and thus control action under these conditions should be limited to hand and wrist motions alone.

3.6.5.2.2 Over 2 g

[HS7028] The system shall place controls used during accelerations between 2 g and 3 g so that the operator can make control inputs via hand/wrist movements and reaches within a forward +/-30 degree cone.

Rationale: Between 2 g and 3 g, controls must be operable by a restrained, suited operator. In a study of reaches under G_x loading with veteran astronauts and aviators as subjects, suited subjects on average exhibited little impact at 2 g but did show a 6% reduction in maximum forward reach displacement at 3 g (Schafer & Bagian, Aviation, Space, and Environmental Medicine, 64: 979, 1993). Hence, between 2 g and 3g, even with highly motivated and trained subjects, reaches will begin to show errors above 2 g, and so control actions should be limited to hand/wrist motions or forward arm movements within a +/- 30 degree cone (apex at the shoulder joint, aligned with the axis of acceleration). For tasks requiring rapid response times or for deconditioned crew, a more conservative approach should be taken – controls should be placed to minimize reach. Awkward shoulder/elbow postures, which could result from reaches to displays/interfaces at close distances, will increase fatigue and errors and should therefore be avoided.

3.6.5.2.3 Supports

[HS7029] The system shall provide stabilizing support for operator limbs during exposure to anticipated accelerations above 2 g for all control tasks.

Rationale: Operator's arms/legs will require proper support and/or restraint to allow for accurate control inputs to remain within task performance limits during elevated g conditions and to prevent inadvertent control inputs during high-g nominal and abort scenarios.

Revision: E	Document No: CxP 70024
Release Date: 11/19/10	Page: 135 of 503
Title: Constellation Program Human-Systems Integration Requirements	

3.6.6 Crew Notifications and Caution and Warning

3.6.6.1 Crew Notifications

3.6.6.1.1 Notifications

[HS7049] The system shall notify the crew when critical crew actions are required.

Rationale: Timely reminders to the crew to perform critical actions are crucial for preventing the occurrence of off-nominal events. Notifications are for actions that are not classified as caution and warning events.

3.6.6.1.2 Manual Silencing

[HS7049A] The system shall provide a manual silencing feature for active auditory annunciators.

Rationale: The crew must have the ability to silence an audible alarm that would otherwise annunciate continuously to prevent it from interfering with their response to the underlying fault. There are well-known instances of aircraft crews that have been functionally incapacitated by audible alarms that they could not cancel.

3.6.6.1.3 Volume Control for Auditory Annunciations

[HS7075] The system shall provide a volume control from 5 to 100% of maximum for audio channels carrying aural annunciations, with the exception of caution and warning signals.

Rationale: The crew should have the ability to adjust volume of non-caution and warning signals to make desired signals intelligible. Analogous to safety requirements in commercial aircraft, the crew does not adjust the caution and warning audio levels. Rather, caution and warning audio levels shall be adjusted relative to the predicted background noise level. There is provision to silence the alarm, but it must be audible initially per ISO 7731(above the masked threshold).

3.6.6.1.4 Speech Intelligibility

[HS7076] Auditory speech annunciations and communications shall provide a level of speech intelligibility equivalent to a 90% word identification rate.

Rationale: This requirement ensures that auditory speech annunciations and communications are sufficiently salient and intelligible. ANSI S3.2-2009, American National Standard Method for Measuring the Intelligibility of Speech over Communicating System is a widely accepted standard for measuring the intelligibility of speech communications.

3.6.6.1.5 Volume Control for Audio Communications

[HS7077] The system shall provide a volume control from 5 to 100% of maximum for each audio channel carrying voice communications.

Revision: E	Document No: CxP 70024
Release Date: 11/19/10	Page: 136 of 503
Title: Constellation Program Human-Systems Integration Requirements	

Rationale: The crew should have the ability to adjust volume in order to communicate through scenarios in which multiple crew or Mission Systems personnel are speaking.

3.6.6.2 Caution and Warning

3.6.6.2.1 Annunciation Hierarchy

[HS9029] The system shall assign off-nominal events into classes including: emergency, warning, caution, and advisory.

Rationale: Off-nominal events are usually divided into the following four classes to simplify training and user comprehension: emergencies, warnings, cautions, and advisories.

3.6.6.2.2 Annunciation Prioritization

[HS9029A] The system shall prioritize vehicle caution and warning annunciations as specified in Appendix K, table Alert Annunciation.

Rationale: The prioritization of caution and warning annunciations is required so that when there is more than one off-nominal event, the crew's attention is focused on the most critical. Simultaneous auditory annunciations should be avoided.

3.6.6.2.3 Visual and Auditory Annunciation

[HS9030] The system shall provide visual and auditory annunciations to the crew for emergency, warning, and caution events.

Rationale: Off-nominal events are usually divided into the following four categories to simplify training and user comprehension: emergencies, warnings, cautions, and advisories. The use of both visual and auditory sensory modalities is required for redundancy, except for advisories, which may not have an auditory annunciation.

3.6.6.2.4 Distinctiveness of Annunciations

[HS9032] The system shall provide distinct audio annunciations and visual indications for Emergency, Warning, Caution, and Advisory alert classes as specified in the Appendix K, table Alert Annunciation.

Rationale: Off-nominal events are usually divided into classes (e.g., emergencies, warnings, cautions, and advisories). The use of distinct auditory annunciations for each of the event classes will simplify training and user comprehension. The use of both visual and auditory sensory modalities is required for redundancy.

Revision: E	Document No: CxP 70024
Release Date: 11/19/10	Page: 137 of 503
Title: Constellation Program Human-Systems Integration Requirements	

3.6.6.2.5 Loss of Annunciation Capability

[HS9032A] The system shall test for a failure of the visual and auditory annunciators on user request.

Rationale: Situational awareness and safety require a capability to test the Caution and Warning system. The crew must be aware as soon as possible when the Caution and Warning annunciation system cannot be relied upon. Examples include a light test or smoke alarm test button.

3.6.7 Crew-System Interaction

3.6.7.1 Subsystem State Information

[HS7058] The system shall provide subsystem state information on request.

Rationale: Subsystem state information is information related to the last-known or current condition of an application, process, or data item. State information includes information such as operating mode, position, and system health. This requirement makes all the data available to the crew if they request the appropriate information for troubleshooting and decision-making. The term "on request" refers to requests by the crew as well as pre-defined system displays (e.g., automatic).

3.6.7.2 System Responsiveness for Discrete Inputs

[HS7058A] The system shall provide feedback within 0.1 second to the crew that a crew discrete input was received.

Rationale: The industry standard is 0.1 second for key response (MIL-STD-1472F). The crew must have feedback that their input was received quickly enough so that they have confidence that the system is working correctly and that they do not make unnecessary additional inputs.

3.6.7.3 System Responsiveness for Continuous Inputs

[HS7058B] The system should provide controls such that the crew is unimpeded by the time lag between the operation of a control and the associated change in system state.

Rationale: This requirement is intended to prevent pilot-induced-oscillation and unnecessary re-actuation of vehicle controls. For example, for many manual piloting tasks, vehicle-induced delays of over 0.1 second are considered unacceptable.

3.6.7.4 Request for Information

[HS7058C] The system should display information within 1.0 second of the crew request.

Revision: E	Document No: CxP 70024
Release Date: 11/19/10	Page: 138 of 503
Title: Constellation Program Human-Systems Integration Requirements	

Rationale: The industry standard is 1.0 second for user requests (MIL-STD-1472F). Excessive delays in the presentation of information lead to a decrease in crew productivity and an increase in frustration.

3.6.7.5 Request for Critical Information

[HS7058D] The system shall display critical information within 1.0 second of the crew request.

Rationale: The industry standard is 1.0 second for user request (MIL-STD-1472F). Excessive delays in the presentation of information lead to an increase in the time required for the crew to respond to changes in vehicle state. This requirement assumes that the display process is already running and that the crew is merely switching between displays.

3.6.7.6 Menu Update Time

[HS7058E] The system shall update menus used for display navigation within 0.5 second of crew selection.

Rationale: The industry standard is 0.5 second for menu update (MIL-STD-1472F). In order for the crew to effectively interact with a menu, selected menus must appear quickly.

3.6.7.7 Command Feedback

[HS7055] The system shall provide feedback to the crew within 2.0 seconds that the crew's command is in progress, completed, or rejected.

Rationale: The industry standard is 2.0 seconds for error feedback (MIL-STD-1472F). The crewmember must have feedback that a step in his or her task has been completed, is in work, or cannot be completed in order to be able to continue their procedure or initiate an off-nominal procedure.

3.6.8 Electronic Procedures

3.6.8.1 Displaying Electronic Procedures System

[HS9025] The system shall provide an electronic procedure system that, while executing a procedure, displays relevant vehicle data within the electronic procedure step being executed.

Rationale: An electronic procedure system is the most effective way for the crew to access, view, and interact with procedures. The intent is that all procedures are available electronically and that, where appropriate, the operator can view telemetry indications from the same view in which they view procedure steps and select commands cued by the electronic procedure system and located on crew displays.

Revision: E	Document No: CxP 70024
Release Date: 11/19/10	Page: 139 of 503
Title: Constellation Program Human-Systems Integration Requirements	

3.6.8.2 Cueing Electronic Procedures System

[HS9025A] The system shall provide an electronic procedure system that, while executing a procedure, cues (or makes available) vehicle software commands that are required to be executed from the procedure.

Rationale: An electronic procedure system is the most effective way for the crew to access, view, and interact with procedures. The intent is that all procedures are available electronically and that, where appropriate, the operator can view telemetry indications from the same view in which they view procedure steps and select commands cued by the electronic procedure system and located on crew displays.

3.6.8.3 Current Procedure Step

[HS9026] The system shall indicate to the crew which step in an electronically displayed procedure is currently being executed.

Rationale: This requirement prevents the crew from missing steps in a procedure by highlighting the step that requires the crew's attention.

3.6.8.4 Completed Procedure Steps

[HS9027] The system shall indicate to the crew which steps in an electronic procedure have been completed.

Rationale: This requirement prevents the crew from re-executing steps in a procedure by highlighting the steps that have been completed.

3.6.8.5 Crew Notification of Required Procedure Action

[HS9028] The system shall notify the crew whenever crew attention is required to complete an electronically displayed procedure.

Rationale: This requirement brings the crew back into a procedure after another agent has completed its steps or after the crew has been away from the procedure for a significant time. This is required to prevent crew inattention to procedures that are interrupted or have many agents performing different steps.

3.7 MAINTENANCE AND HOUSEKEEPING

This section includes requirements for the maintenance and housekeeping of vehicle subsystems and components during flight.

Revision: E	Document No: CxP 70024
Release Date: 11/19/10	Page: 140 of 503
Title: Constellation Program Human-Systems Integration Requirements	

3.7.1 Maintenance

3.7.1.1 Efficiency

3.7.1.1.1 ORU Change-out

[HS8001] The system shall enable Orbital Replacement Unit (ORU) change out and planned equipment reconfiguration by personnel wearing clothing appropriate to the environment and phase of flight, including post-landing.

Rationale: Removing and replacing equipment may need to be done during any phase of flight, in which the vehicle may be in different gravity conditions, and by individuals wearing protective clothing and equipment that may limit mobility. Examples of protective clothing and equipment include flight suits and Self-Contained Atmosphere Protective Ensemble (SCAPE) suits. Equipment includes everything that is planned to be maintained in flight, from the Line Replaceable Unit (LRU) down to the component level. Components may include computer cards, power supplies, or in some cases individual electronic components.

3.7.1.1.2 Maintenance Time per Day

[HS8002] The system shall require less than 2 person-hours per day of preventive maintenance and housekeeping during flight.

Rationale: Flight crew time for productive mission activities is at a premium during flight. Preliminary studies based on ISS operation indicate that 2 person-hours per day of overhead activities is the maximum amount of time that can be allocated without incurring detrimental effects on primary mission activities. The requirement is allocated to each flight vehicle (e.g., Orion and Altair) individually, not in a docked configuration.

3.7.1.1.3 ORU Maintenance Time

[HS8003] ORUs shall have a total maintenance time for removal and replacement of no more than 3 hours.

Rationale: Crew time is at a premium during flight. System designs should support efficient maintenance, which includes safing, access, removal, replacement, and closeout back to original hardware configuration. Previous spaceflight experience and engineering judgment by subject matter experts indicate that all of these activities can be accomplished in 3 hours or less if the vehicle is designed to facilitate maintenance.

3.7.1.1.4 ORU Replacement Time/Maintenance

[HS8003-Objective] ORUs shall have a total maintenance time for removal and replacement of no more than 1 hour.

Rationale: Crew time is at a premium during flight. System designs should support efficient maintenance. Maintenance includes safing, access, removal,

Revision: E	Document No: CxP 70024
Release Date: 11/19/10	Page: 141 of 503
Title: Constellation Program Human-Systems Integration Requirements	

replacement, and closeout back to original hardware configuration. This is an objective requirement to reduce the on-orbit crew time spent on ORU changeout.

3.7.1.1.5 Access Points

[HS8026] Controls and maintenance access points should not be located near electrical, mechanical, and other hazards.

Rationale: Keeping hazardous equipment away from nominal work areas is highly desired to mitigate safety risks to the flight and ground crews. This requirement is a “should” because it is recognized that maintainers will need to access all parts of the vehicle and not all hazards can be completely eliminated.

3.7.1.2 Error-Proof Design

3.7.1.2.1 Physical Features

[HS8005] Hardware maintained or reconfigured by the flight crew shall include physical features to prevent improper mounting.

Rationale: Improperly mounting equipment can result in unsafe conditions for flight crews, can increase the risk of Loss of Crew (LOC)/Loss of Mission (LOM) events, and may cause damage to hardware. Physical features lessen the likelihood of human error. Examples of physical features include supports, guides, size or shape differences, fastener locations, and alignment pins. Physical features are the first line of defense for preventing such errors.

3.7.1.2.2 Labeling and Marking

[HS8006] Equipment shall provide visual indication for correct mounting in accordance with HS7036.

Rationale: Improperly mounted equipment can lead to unsafe conditions for flight and ground crews, can increase the risk of LOC or LOM, and/or may cause damage to hardware. In addition to physical features, labeling or marking mitigates human error. Visual indication might include any marking on or adjacent to the equipment interface, labels, or color coding that provides information about mounting. Unique labeling of equipment provides an indication that the equipment to be mounted and the mounting location match.

3.7.1.2.3 Interchangeability

[HS8007] ORUs that are not interchangeable functionally shall not create a hazard if interchanged physically.

Rationale: The intent is to prevent the installation of equipment that may physically fit into a location but that cannot perform its necessary function, or that performs a different function that can damage the associated system (e.g., two check valves that are physically identical but open at different pressures).

Revision: E	Document No: CxP 70024
Release Date: 11/19/10	Page: 142 of 503
Title: Constellation Program Human-Systems Integration Requirements	

3.7.1.2.4 Connectors

[HS8008] Connectors shall have physical features that preclude mis-mating and misalignment.

Rationale: Improper mating or misalignment of connectors can lead to short circuit or open circuit conditions that can reduce the safety of flight and ground crews, can increase the risk of LOC or LOM events, and may cause damage to hardware. Physical features are often used to lessen the likelihood of human error. Physical features to preclude improper mating typically include keying, such that connectors cannot be mated to the incorrect location.

3.7.1.2.5 Visual Indication

[HS8045] The system shall provide an orientation cue for the correct mating of connectors in accordance with HS7036.

Rationale: Labeling of connectors ensures efficient identification of connectors to be mated, which lowers the risk of improper mating and optimizes use of crew time. Visual indication might include any marking on or adjacent to the equipment interface, labels, or color coding that provides information about mounting. Identification as a label function is covered in the User Interface section of the HSIR.

3.7.1.2.6 Connector Mating Indication

[HS8046] Connectors shall indicate mating completion.

Rationale: Incomplete electrical connector mating can result in a short circuit or an open circuit. Incomplete fluid connector mating can result in unexpected and possibly hazardous fluid release when the region of the system containing the fluid connector is pressurized. These situations reduce the safety of flight or ground crews, increase the risk of LOC or LOM events, and/or may damage hardware. Indication of a positive mating may be achieved using visual indicators, tactile feedback indicators, or a combination of both types of indications.

3.7.1.2.7 Unique Identification Labeling

[HS8047] Equipment shall provide labeling for unique identification of the equipment in accordance with HS7036.

Rationale: Labeling of equipment ensures efficient identification, which lowers the risk of improper use and optimizes use of crew time.

Revision: E	Document No: CxP 70024
Release Date: 11/19/10	Page: 143 of 503
Title: Constellation Program Human-Systems Integration Requirements	

3.7.1.3 Access

3.7.1.3.1 Disturbance of Equipment

3.7.1.3.1.1 Disturbance of Equipment

[HS8053] The system should be maintainable without removal of ORUs that are not directly the subject of maintenance activity.

Rationale: Not having to remove ORUs for maintenance tasks will minimize mission maintenance times and maximize system availability.

3.7.1.3.2 Visual Access

3.7.1.3.2.1 Visual Access

[HS8009] The system shall provide visual access to crew interfaces during planned maintenance activities.

Rationale: Direct line-of-sight visual access reduces the likelihood of human error that can occur when blind (by feel) operations or operations requiring the use of specialized tools (e.g., mirrors or bore scopes) are performed. Direct line of sight is intended to be required when the item is being manipulated by the crew. Crew interfaces include items such as connectors and fasteners. Direct line of sight for pin inspection is not required, though it is desired where possible. This does not apply to blind-mate connectors with guides, which are automatically de-mated and mated as a piece of equipment is removed and replaced.

3.7.1.3.3 Physical Access

3.7.1.3.3.1 Physical Access

[HS8010] The system shall provide the crew, wearing protective clothing when appropriate, with the work envelope to perform all expected maintenance activities.

Rationale: Adequate access and working space is needed to allow personnel to efficiently access equipment in a way that minimizes the potential for human error or human induced damage. Access, including reach envelope, is required for maintenance activities. Access and work envelope are different for differing tasks. In particular, protective garments may be required by the flight crew and must be accommodated.

3.7.1.3.4 Maintenance Hazard

3.7.1.3.4.1 Maintenance Hazard

[HS8015] The system shall be maintainable without causing critical or catastrophic hazards.

Rationale: Performance of maintenance must not introduce additional hazards.

Revision: E	Document No: CxP 70024
Release Date: 11/19/10	Page: 144 of 503
Title: Constellation Program Human-Systems Integration Requirements	

3.7.1.3.5 Crew Control of Power

3.7.1.3.5.1 Crew Control of Power

[HS8055] The system shall provide the crew with capability to control the interruption of power to an electrical circuit and confirm the de-energized status of the circuit that could expose crewmembers to voltages in excess of 32 V.

Rationale: This requirement addresses a maintenance issue by providing the flight crew with the ability to interrupt power, as opposed to only remote ground control, so that an IVA crewmember performing a maintenance action will have the ability to interrupt power to the maintenance area and the opportunity to confirm the de-energized status of the electrical circuitry before initiating work or during the course of activities in that area.

3.7.1.4 Failure Notification

3.7.1.4.1 Failure Notification

[HS8016] The system shall alert the crew when flight-critical equipment has failed and when it is not operating within tolerance limits without removal of that equipment.

Rationale: This provides a means of expediting failure troubleshooting and of ensuring that the crew has adequate situational awareness of what functionality has been lost. The alert in some cases may be a display that includes quantitative data indicating the extent of the out-of-tolerance condition.

3.7.1.5 Circuit Protection

3.7.1.5.1 No Fuses for Dynamic Flight Phases

[HS8017] Fuses shall not be used to protect circuits where reset may be required during dynamic phases of flight.

Rationale: During dynamic phases of flight the crew may need to restore system operation rapidly to maintain vehicle control. The intent of the requirement is to preclude the use of destructible circuit protection devices, such as fuses. Finding, sizing, and replacing fuses takes more time than resetting circuit breakers. Nominal operation of the devices returns the circuit to normal functionality with a single crew task.

3.7.1.5.2 Circuit Breakers Instead of Fuses

[HS8018] Circuit breakers should be used in preference to fuses.

Rationale: There are several reasons why circuit breakers are preferred, including the ability to rapidly reset breakers, the elimination of the storage, logistics supply, and training required to provision spare fuses. It is recognized that fuses probably cannot be totally eliminated, but where fuses are used rather than circuit breakers, the decision should be backed up by analysis.

Revision: E	Document No: CxP 70024
Release Date: 11/19/10	Page: 145 of 503
Title: Constellation Program Human-Systems Integration Requirements	

3.7.1.5.3 Replacement Without Tools

[HS8020] In-flight replaceable fuses shall be removable and replaceable without the use of tools.

Rationale: The elimination of tools eliminates the mass, volume, logistics supply, and training required to provision the tools. This is not intended to preclude the use of a tool for the access panels that may need to be opened before fuse replacement.

3.7.1.5.4 Replacement Without Component Removal

[HS8021] In-flight replaceable fuses shall be removable and replaceable in-flight without requiring removal of other components.

Rationale: The removal of non-failed components to access fuses increases the likelihood of damage to the non-failed components, increases the time required to replace the fuse, and adds unnecessary functional retest of non-failed items. This is not intended to preclude the use of access panels that may need to be opened before fuse replacement.

3.7.1.5.5 Circuit Breaker Resetting

[HS8022] Circuit breakers, which may require actuation during critical flight phases, shall be operable without the removal or opening of access panels.

Rationale: Circuit breakers for ascent, entry, and landing phases of a mission must be operated quickly.

3.7.1.5.6 Trip Indication

[HS8023] The system shall provide an indication to the crew when an in-flight replaceable fuse or circuit breaker has opened a circuit. This requirement does not apply to circuit protection within portable loads.

Rationale: This requirement provides a means of expediting failure troubleshooting and ensures that the crew has adequate situational awareness of what functionality is available and what has been lost.

3.7.1.6 Electrostatic Discharge (ESD)

3.7.1.6.1 Electrostatic Discharge

[HS8024] Equipment that is susceptible to electrostatic discharge damage during operation or planned in-flight maintenance shall be labeled as sensitive to electrostatic discharge damage in accordance with HS7036.

Rationale: This labeling is intended to notify the operator of possible electrostatic discharge sensitivity of the device, which may damage the equipment.

3.7.1.7 Fasteners

Revision: E	Document No: CxP 70024
Release Date: 11/19/10	Page: 146 of 503
Title: Constellation Program Human-Systems Integration Requirements	

3.7.1.7.1 Fastener Heads

[HS8029] Tool-operated fasteners removed and replaced by the crew shall have self-centering, anti-cam-out heads.

Rationale: This requirement is intended to exclude slotted fasteners—which are not self-centering—and Phillips fasteners—which require the constant application of force along the axis of the fastener to keep the tool seated in the fastener (i.e., to prevent "cam-out"). This will reduce the likelihood of fastener stripping and will make it easier for the crew to perform any in-flight maintenance. Examples of acceptable fasteners are internal hex-head, Torq-Set, Torx, and Tri-Wing.

3.7.1.7.2 Fastener Number and Variety

[HS8030] The number and variety of fasteners used should be the minimum required to meet stress, bonding, pressurization, shielding, thermal, and safety requirements for items that may be removed by the flight crew.

Rationale: This is intended to balance the flight and ground crew effort required to remove fasteners with the design needs that require the fasteners (to satisfy stress, bonding, pressurization, shielding, thermal, and safety requirements). This implies that analysis is performed to determine the minimum number of fasteners that meets the design needs, and that no more than this number be used. This requirement is also intended to be applied to the variety of fastener head types (e.g., Torq-set, hex-head, etc.).

3.7.1.7.3 Captive Fasteners

[HS8031] Fasteners operated by the crew during maintenance tasks shall be captive.

Rationale: A captive fastener is one that is automatically retained in a work piece when it is not performing its load-bearing job. Captive fasteners, therefore, do not require the flight crew to restrain and store them during maintenance, and can more easily be installed with one hand, reducing maintenance times and reducing the chance of fastener loss.

3.7.1.8 Fluids

3.7.1.8.1 Equipment Isolation

[HS8032] The system shall provide for isolation of fluids in ORUs during maintenance tasks.

Rationale: Isolation valves and quick-disconnect couplings allow for more efficient system maintenance, permit isolation and servicing, aid in leak detection, and eliminate the need to drain and refill systems.

Revision: E	Document No: CxP 70024
Release Date: 11/19/10	Page: 147 of 503
Title: Constellation Program Human-Systems Integration Requirements	

3.7.1.8.2 Hazardous Levels of Fluid Leakage

[HS8034] Fluid isolation features shall not leak hazardous levels of fluid exceeding concentrations identified in JSC 20584, Spacecraft Maximum Allowable Concentrations (SMAC) for Airborne Contaminants.

Rationale: The leakage of fluids (liquid or gas) is a crew health issues during 0-g operations (e.g., inhalation hazard). Additionally, leakage during any mission phase (flight or ground) can cause hazardous conditions, increase housekeeping tasks, and may damage equipment. This requirement is intended to cover both toxic and non-toxic fluids.

3.7.1.9 Tools

3.7.1.9.1 Common Toolset

[HS8037] The system should be maintainable and reconfigurable on orbit using a minimum set of tools that are as common as feasible with the other systems.

Rationale: A minimum set of tools, common with other systems, allows for many maintenance tasks to be performed without a proliferation of unique tools and reduces the training and support requirements for the system. Proprietary or unusual fasteners should be avoided, e.g., design to a common internal hex tool versus a new size/shape not commonly found in a tool kit.

3.7.1.9.2 Tool Clearance

[HS8052] The system shall provide tool clearances for tool installation and actuation for all tool interfaces during in-flight maintenance.

Rationale: Tools to be used for in-flight maintenance must be identified by the hardware developer, and clearance for its application must be accommodated to ensure that maintenance tasks can be performed.

3.7.1.9.3 Tool Usage

[HS8054] The system shall be maintained or reconfigured on-orbit using only those tools that can be used by the crew per Appendix B, table Unsited Strength Data for the maintenance or reconfiguration task.

Rationale: It is necessary to ensure that all human-systems interfaces accommodate the entire current and future Minimum Crew Operational Load limits. Analysis and testing provide the opportunity to determine that hardware is within the Minimum Crew Operational Loads limits. Therefore, analysis and testing are necessary to ensure that all current and future crewmembers are able to interface and operate with the system hardware.

3.7.2 Housekeeping

Revision: E	Document No: CxP 70024
Release Date: 11/19/10	Page: 148 of 503
Title: Constellation Program Human-Systems Integration Requirements	

3.7.2.1 Design for Cleanliness

3.7.2.1.1 Microbial Contamination

[HS8041] System interior surfaces shall be compatible for cleaning bacterial contamination to a level of 500 CFUs per 100 cm² or fewer.

Rationale: This requirement is intended to ensure that bacterial contamination on spacecraft internal surfaces can be removed to mitigate the risk of such contamination to the crew. The limit is from the SSP 50260, ISS Medical Operations Requirement Document (ISS MORD).

3.7.2.1.2 Fungal Contamination

[HS8042] System interior surfaces shall be compatible for cleaning of fungal contamination to a level of 10 CFU per 100 cm² or fewer.

Rationale: This requirement is intended to ensure that fungal contamination on spacecraft internal surfaces can be removed to mitigate the risk of such contamination to the crew. The limit is from the SSP 50260, ISS Medical Operations Requirement Document (ISS MORD).

3.7.2.1.3 Condensation Prevention on Interior Surfaces

[HS8051] The system shall limit condensation persistence to 1 hour a day on surfaces within the internal volume during the mission.

Rationale: The formation of water condensate on internal surfaces has been demonstrated on the Mir and the ISS to promote the growth of fungi. Examples of moisture buildup from previous spaceflight missions that resulted in fungal growth include non-insulated cold surfaces and designed operations, which moisten surfaces (such as wetting a cloth) without appropriate drying. Condensation on a non-ventilated surface will be difficult to dry.

3.7.2.2 Replacement of Air Filters

3.7.2.2.1 Replacement of Air Filters

[HS8043] The system should allow a crewmember to remove and replace air filters that require in-flight servicing without the use of tools.

Rationale: Crew time is at a premium during a mission. Tools will not be used in order to minimize the impacts to preventive maintenance and reduce overall weight.

3.8 INFORMATION MANAGEMENT

Information management is the act of performing functions with electronic data, including data input, organization, internal processing, storage, dissemination, and disposal. Information management functions are performed by crew and Mission Systems using displays on display devices. This section contains requirements related

Revision: E	Document No: CxP 70024
Release Date: 11/19/10	Page: 149 of 503
Title: Constellation Program Human-Systems Integration Requirements	

to information management and the use of electronic data across Constellation systems. Requirements specific to the design of the crew interfaces to these data are found in Section 3.6, Crew Interfaces.

3.8.1 Crew Operability

3.8.1.1 Crew Operability

[HS9021] The system shall provide methods and tools for the crew to perform information management functions.

Rationale: Information management functions may need to be performed at times when only the crew can perform them, for example when there is no communication with Mission Systems. Examples of information management functions include: graphing system trend information, composing and sending electronic mail, searching for and within procedures, and viewing training materials. Information management functions do not necessarily reside on the flight avionics system.

3.8.2 Data Available

3.8.2.1 Data Rate

[HS9014] The system should provide data acquired at a rate that enables the crew and ground personnel to perform tasks.

Rationale: Different classes of data must be gathered at different minimum rates to be useful to the crew or ground personnel, for example, navigation data might be gathered once per second, payload data once per minute, and routine medical data once per day.

3.8.2.2 Data Fidelity

[HS9040] The data shall have the fidelity for the crew to perform tasks.

Rationale: Data fidelity (accuracy, precision, reliability, latency, and resolution) is essential for proper vehicle functioning and for the crew to make timely and correct decisions, particularly in critical operations.

3.8.3 Data Distribution

3.8.3.1 Locations of Data

[HS9018] The system shall provide the crew with data to perform tasks at each workstation where those tasks can be performed.

Rationale: The crew may choose to perform information management functions at varied locations throughout the vehicle. For example, a crewmember reading an online maintenance schematic may choose to move away from a crewmember having a private medical conference. The use of alternative technologies such as digital paper, digital cameras, Personal Digital Assistants

Revision: E	Document No: CxP 70024
Release Date: 11/19/10	Page: 150 of 503
Title: Constellation Program Human-Systems Integration Requirements	

(PDAs), or tablet computers may suffice to meet this requirement; however, the use of printed material, labels, or other displays to provide critical information at workstations is not precluded.

3.8.3.2 Wired Network

[HS9019] The system shall provide a wired distribution system for data.

Rationale: ISS and Shuttle Program history has shown that wireless connections can be unreliable and difficult to troubleshoot; therefore, they are not desired as the sole option for critical functions. It is important to have a backup wired distribution system. This requirement is not intended to preclude the use of a primary wireless distribution system, which would be highly desirable.

3.8.3.3 Wireless Network

[HS9020] The system shall provide a wireless distribution system for data.

Rationale: ISS and Shuttle Program history has shown that wireless connectivity is desirable because it reduces clutter within the vehicle and improves mobility and productivity. Because wire clutter is incompatible with launch and entry activities (such as emergency egress), a wireless solution is especially desirable. This requirement provides the capability for wireless; however, it does not dictate that all data be transmitted wirelessly.

3.8.4 Data Backup

3.8.4.1 Manual Information Capture and Transfer

[HS9042A] The system shall provide a method for the crew to capture and transfer information from any display in a format that provides mobility and the ability to annotate.

Rationale: Users must be able to capture the contents of an information display for mobility or to make annotations. The use of alternative technologies such as digital paper, digital cameras, Personal Digital Assistants (PDAs), or tablet computers would allow annotations to be shared more easily with Mission Systems, but this requirement does not preclude the use of printed material.

3.9 GROUND MAINTENANCE AND ASSEMBLY

This section addresses tasks to be performed by NASA and its launch site contractors in accomplishment of launch site processing and ground maintenance. Launch site processing includes vehicle assembly (e.g., Ares I + Orion) activities that occur within the Outer Mold Line of the Launch Stack, Launch Stack physical integration (e.g., umbilical integration), and launch preparation (e.g., propellant loading). Ground maintenance includes corrective and preventive maintenance activities associated with Line Replaceable Unit (LRU) removal and replacement. These requirements do not apply to unplanned repair at the launch site, build activities at the manufacturing site, or

Revision: E	Document No: CxP 70024
Release Date: 11/19/10	Page: 151 of 503
Title: Constellation Program Human-Systems Integration Requirements	

potential build up at the launch site prior to system integration (for example, build up of the Orion). The requirements in this section apply only to those aspects of design that are under direct control of the vehicle developers, but not to the design of external Ground Support Equipment (GSE) and test systems. These requirements do not apply to any powered portable equipment that is intended for flight.

3.9.1 Ground Anthropometry, Biomechanics, and Strength

3.9.1.1 Ground Anthropometry, Biomechanics, and Strength

[HS10008] The system shall provide worksites for launch site processing and maintenance tasks that are sized to accommodate critical dimensions of the ground crew population based on 1988 U.S. Army Anthropometry Survey (ANSUR) database (NATICK/TR-89/044) 5th to 95th percentiles.

Rationale: The 5th to 95th percentiles were selected in order to ensure that a minimum level of accommodation is provided to the ground crew. The intent of the requirement is to ensure that at least some members of the ground crew may perform a task while not necessarily ensuring that all members can perform every task. Critical dimensions are defined using task analysis. Though the ANSUR database may not directly reflect the population of the ground crew, this is a readily available standard database, and the intent of the requirement may be met using this database. For some dimensions, civilian measurements greatly exceed ANSUR measurements; however, designing for 5th percentile to 95th percentile ensures that tasks will accommodate most ground crew. The 5th percentile is based on female dimensions, and the 95th percentile is based on male dimensions. Joint range of motion limitations for ground crew may be estimated using the joint mobility values in NASA-STD-3000, (Section 3.3.2.3, Joint Motion Data Design Requirements).

3.9.2 Ground Natural and Induced Environments

<Reserved>

3.9.3 Ground Safety

3.9.3.1 Ventilation Openings

[HS10027] Ventilation openings within the reach envelope of ground crew during launch site processing shall preclude inadvertent insertion of foreign objects, which might damage the contents or injure the crew.

Rationale: Ventilation openings are needed by some flight components. If these components are within the reach envelope of ground crew during performance of assembly and maintenance activities, they should be protected from accidental insertion of tools or body parts. Such insertion could pose a hazard to crew or to the hardware.

Revision: E	Document No: CxP 70024
Release Date: 11/19/10	Page: 152 of 503
Title: Constellation Program Human-Systems Integration Requirements	

3.9.3.2 Ground Processing Hardware Access

[HS10030] The system shall protect ground crews against injury from sharp edges.

Rationale: Protection of ground crews from injury controls ground operations costs. In those areas that ground crew would access for ground processing and maintenance, the design should protect them from sharp edges and corners. The intent of this requirement is for a design solution, not an operational solution, as the latter results in expensive recurring costs. The requirement might be met by rounding of edges and corners or by designing flight structure that hides sharp edges and corners from crew access during planned operations. It cannot be met by design of remove-before-flight protective structure.

3.9.3.3 Hazards Labeling

[HS10033] The system shall provide labels to identify hazards to ground crew or to equipment.

Rationale: Assembly and ground maintenance tasks can require ground crew to work with equipment that is susceptible to damage or that presents a hazard to the crew. Hazard labels are required for protection of ground crews and to alert ground crews to special susceptibilities of equipment (e.g., electrostatic discharge).

3.9.4 Ground Architecture

This section contains requirements for the overall layout of the vehicle to aid the ground crew in performing launch processing and assembly. Specific topics include layout of functional areas, translation paths.

3.9.4.1 Work Station Layout Interference

[HS10047] The system should separate functional areas where ground processing activities would detrimentally interfere with each other.

Rationale: Co-location of unrelated activities could degrade operations, resulting in increased workload and operational delays. This consideration will be difficult to meet in a small volume, but every effort should be made to separate functions and capabilities that could operationally conflict with each other or that produce environmental conditions that will conflict with other tasks, e.g., SCAPE operations with wire testing and soldering next to clean room environments.

3.9.4.2 Work Station Layout Sequential Operations

[HS10048] The system should co-locate functional areas in which sequential ground operations are performed.

Rationale: Co-location of related, functional work areas can reduce transit time, communication errors, and operational delays. This consideration may seem to be met simply because of a vehicle's small size, but every effort should be made

Revision: E	Document No: CxP 70024
Release Date: 11/19/10	Page: 153 of 503
Title: Constellation Program Human-Systems Integration Requirements	

to group functions and capabilities supporting a task in as efficient a manner as possible to reduce crew workload. For example, time to build access platforms inside the vehicle could be reduced if all similar operations are performed sequentially in a co-located area before platform removal.

3.9.5 Ground Crew Functions

<Reserved>

3.9.6 Ground Crew Interfaces

A system's ground crew interface is any part of that vehicle through which contact is made or information is transferred between the ground crew and the vehicle, whether by sight, sound, or touch. Usable, well-designed ground crew interfaces are critical for ground crew safety and productivity, and to minimize training requirements. This section provides requirements for ground crew-controlled processes and the design of ground crew interfaces, including displays, display devices, and controls. A display is anything that provides information to crewmembers on a display device. A display device is the hardware that displays information to crewmembers. A control is anything that accepts ground crewmember commands or inputs, whether hardware or software. The requirements stated herein apply to all ground crew launch processing activities, with or without Personal Protective Equipment (PPE).

3.9.6.1 Labeling

[HS10039] The system shall provide labels for ground crew interface controls and indicators.

Rationale: Controls and data items must have labels to aid in ground crew training and error-free operation.

3.9.6.2 Ground Labeling: Non-Interference with Flight Labels

[HS10055] Labels or part markings used for ground assembly and handling shall not interfere with crew interface flight labeling, visually or operationally.

Rationale: Crew interface flight labeling must take precedence over ground labeling to ensure safe flight operations. Interference with the flight labeling by ground labeling can cause confusion for the crew. When and where possible, the ground labeling should not be visible to the crew in-flight.

3.9.6.3 Consistent Crew Interfaces

[HS10050] The system should provide ground crew interfaces that are consistent in appearance and operation across Constellation systems.

Rationale: The intent of this statement is to ensure commonality and consistency across flight systems. This will facilitate learning and minimize interface-induced ground crew error.

Revision: E	Document No: CxP 70024
Release Date: 11/19/10	Page: 154 of 503
Title: Constellation Program Human-Systems Integration Requirements	

3.9.6.4 Legibility

[HS10051] The system shall provide ground crew labels and displays that are legible under task conditions.

Rationale: Legibility is important for the ground crew's timely and accurate processing of information.

3.9.6.5 Written Text

[HS10052] Language text shall be written in the American English language, based on Webster's New World Dictionary of American English.

Rationale: The intent of this requirement is to ensure as much commonality and consistency as possible in written text (i.e., language and spelling) across vehicle subsystems and across flight systems. Exceptions include acronyms and commonly understood words and terms that are derived from other languages where there is no suitable English replacement. This will facilitate learning and minimize interface-induced ground crew error.

3.9.6.6 Use of Color

[HS10053] The system should provide an additional cue to convey ground crew interface information when color is used to convey meaning.

Rationale: Redundant coding is required to accommodate the variability in people's capability to see color under different lighting conditions, and to increase the saliency of identification markings. Redundant cues can include labels, icons, and speech messages.

3.9.6.7 Work Envelope Volumes

[HS10002] The system shall provide work envelope volumes needed to perform corrective and preventive maintenance tasks, as well as assembly and other launch site processing tasks.

Rationale: The flight system components/subsystems (e.g., Ares I stages, Orion Service Module [SM], and Crew Module [CM]) must be assembled by the ground crew with sufficient work envelope to accomplish tasks. Many of these tasks will constitute mating of components (bolts, connectors, etc.) across the interface between Elements (e.g., Ares I: First and Second Stages) or between systems (Ares I and Orion). These envelopes will, therefore, be identified by Vehicle-level task analyses and documented in Interface Control Documents (ICDs). Corrective and preventive maintenance tasks that are accomplished fully within one Element may be analyzed at the Element level. In this case, corrective maintenance activities include only those associated with LRU removal and replacement. This requirement does not apply to unplanned repair at the launch site, build activities at the manufacturing site, or potential build up before system integration. Guidelines for envelope definition are found in FAA-HF-STD-001,

Revision: E	Document No: CxP 70024
Release Date: 11/19/10	Page: 155 of 503
Title: Constellation Program Human-Systems Integration Requirements	

Section 14.1. Sufficient envelope is defined by task analyst using this document and based on anthropometric requirements and task definition. The envelope definition will be concurred with by Level II.

3.9.6.8 Reach Envelope Volumes

[HS10004] The system shall provide reach envelope volumes needed to perform corrective and preventive maintenance tasks, as well as assembly and other launch site processing tasks.

Rationale: The vehicle components must be designed to be assembled and maintained by the ground crew with sufficient reach envelope to accomplish tasks. Many of these tasks will constitute mating of components (bolts, connectors, etc.) across the interface between Elements (e.g., Ares I: First and Second Stages) or between systems (Ares I and Orion). These envelopes will, therefore, be identified by Vehicle-level task analyses and documented in ICDs. In this case, corrective maintenance activities include only those associated with LRU removal and replacement. This requirement does not apply to unplanned repair at the launch site, build activities at the manufacturing site, or potential build up before system integration. Guidelines for envelope definition are found in FAA-HF-STD-001, Section 14.1-14.5 and NASA-STD-3000, Section 3.3.3, as applied to ground crews. Sufficient envelope is defined by task analysts using these documents and based on anthropometric requirements and task definition. The envelope definition will be concurred with by Level II.

3.9.6.9 Ground Crew Visual Access

[HS10006] The system shall provide the ground crew visual access needed to perform corrective and preventive maintenance tasks, as well as assembly and other launch site processing tasks.

Rationale: The system components must be designed to provide the ground crew with visual access of the tasks to be performed as part of launch system assembly and of corrective and preventive maintenance. That is, all tasks should have the object of the task (bolt, connector, etc.) in the direct line of sight of the ground crewmember performing the task, with the vehicle in the assembled, vertical configuration. The envelopes will be identified by both the subsystem-level and the Vehicle-level task analyses. In this case, corrective maintenance activities include only those associated with LRU removal and replacement. This requirement does not apply to unplanned repair at the launch site, build activities at the manufacturing site, or potential build up before system integration. Guidelines for envelope definition are found in FAA-HF-STD-001, Section 14.2 and MIL-STD-1472F, Section 5.6.3.1.5. Mirrors and periscopes should not be required. Sufficient envelope is defined by task analyst, based on anthropometric requirements and task definition, and will be concurred with by Level II.

Revision: E	Document No: CxP 70024
Release Date: 11/19/10	Page: 156 of 503
Title: Constellation Program Human-Systems Integration Requirements	

3.9.7 Launch Site Processing and Ground Maintenance

3.9.7.1 Line Replaceable Units (LRUs)

3.9.7.1.1 LRU Installation

[HS10012] Line Replaceable Units (LRUs) shall include physical features that prevent incorrect installation.

Rationale: Each LRU is verified for flight in its designed orientation and configuration. Not only is functionality of the item at risk if it is improperly installed, structural failure could result. Physical features that ensure proper installation (e.g., supports, guides, size, or shape differences; fastener locations; and alignment pins) will at the same time assure that cables and fluid lines are not improperly stressed and that all fasteners are properly torqued.

3.9.7.1.2 LRU Mounting/Alignment Labels/Codes

[HS10013] LRUs shall be labeled or coded to identify proper mounting and alignment.

Rationale: Labels provide contextual information to help assure that the ground crew does not attempt to install an LRU incorrectly; such an attempt could damage the LRU or the interfaces on the vehicle. Each LRU is verified for flight in its designed orientation and configuration.

3.9.7.1.3 LRU Interchangeability

[HS10014] LRUs that are not interchangeable functionally shall not be interchangeable physically.

Rationale: This requirement addresses installation of the wrong component. While some LRUs may be used for the same function in multiple instances (e.g., redundant strings) many may be physically similar but functionally distinct. In such cases, installation in the wrong location could result in damage to the LRU or to the system into which it is inserted. This requirement is intended to preclude such installation in the wrong location.

3.9.7.1.4 LRU Tracking Labels

[HS10031] LRUs shall be labeled with a logistics tracking label that uses the same standard as flight hardware.

Rationale: Logistics tracking labels shall be consistent with the programmatic logistics and supportability standards.

3.9.7.1.5 LRU Labeling

[HS10032] LRUs and flight components that are part of maintenance and launch site tasks shall be labeled to provide identification.

Revision: E	Document No: CxP 70024
Release Date: 11/19/10	Page: 157 of 503
Title: Constellation Program Human-Systems Integration Requirements	

Rationale: This requirement includes identification of the part, indication of male and female (for fluid connectors), jack or plug (electrical connectors), flow direction for fluid lines, and other similar information critical to assembly and maintenance tasks. The naming used on labels must be consistent with programmatic naming conventions.

3.9.7.1.6 LRU Protrusions

[HS10042] LRU hardware shall have handling provisions for ground crews.

Rationale: This requirement is being included to avoid damage to flight hardware and to prevent injury to ground crew. Labels, procedures, handles, or GSE attach points can be used to implement this requirement. Damage to flight hardware and injury to the ground crew can result from poor grips to a non-handle protrusion or from protrusions that do not hold the weight of the LRU. Non-handle protrusions can break and lead to dropping flight hardware or to disorienting the balance of the ground crew. This can be prevented by clearly labeling handles as the designated lift points for the hardware.

3.9.7.1.7 LRU Weight Limit

[HS10045] LRUs that are required to be installed by one ground crewperson without Ground Support Equipment shall not exceed the safe weight limit as determined by the NIOSH lifting equation according to guidelines in Appendix L.

Rationale: The NIOSH lifting equation was designed to determine a recommended weight limit for safely lifting loads. It accounts for factors that would affect a person's ability to lift, including the position of the load relative to the body, the distance lifted, the frequency of lifts, and the coupling (gripping) method. These various factors need to be accounted for while determining safe weight limits for the ground crew during assembly, processing, and maintenance tasks. The Applications Manual for the Revised NIOSH Lifting Equation provides the detailed methods for applying the equation to a variety of tasks along with examples. A summary of the Applications Manual is included in Appendix L.

3.9.7.1.8 LRU Removal Without Component Removal

[HS10054] The system should allow for LRU removal without removing other components.

Rationale: Removing LRUs without having to remove other components may protect against damage and simplify vehicle maintenance tasks.

3.9.7.1.9 LRU Removal and Replacement

[HS8004] A single LRU removal and replacement activity, which is intended to be accomplished by a single technician, should be designed to be complete within an 8-hour shift.

Revision: E	Document No: CxP 70024
Release Date: 11/19/10	Page: 158 of 503
Title: Constellation Program Human-Systems Integration Requirements	

Rationale: This requirement applies only to LRUs that can be removed and replaced by a single technician. Total LRU removal and replacement time includes pre-operation set-up (i.e., safing, access, tool retrieval, etc.) removal, replacement, and post-operation closure (i.e., access panels replacement, final close-out inspections, restoration of original hardware configuration, etc.). All of these tasks should be achievable within an 8-hour shift by one technician. An LRU design that requires minimal time requirements for removal and replacement helps to ensure interfaces to reduce the potential of human error and collateral damage during removal and replacement.

3.9.7.2 Connectors

3.9.7.2.1 Connector Mismatching

[HS10015] The system shall have physical features that preclude mismatching of connectors that are in the same physical location during launch site processing and corrective and preventive maintenance.

Rationale: Connector similarity could lead to inadvertent mismatching, which is the mating of a male plug to the wrong female jack. Mismatching can damage pins or mechanisms, or even (once powered or filled with fluids) lead to personnel injury or equipment damage. In this case, corrective maintenance activities include only those associated with LRU removal and replacement. This requirement does not apply to unplanned repair at the launch site, build activities at the manufacturing site, or potential build up before system integration.

3.9.7.2.2 Connector Mating Labels

[HS10017] Connectors in the same physical location that must be mated during launch site processing and maintenance shall have labels that define correct mating.

Rationale: Labels will identify which connector plug is intended to be mated with which jack, as well as proper orientation for mating.

3.9.7.3 Captive Fasteners

3.9.7.3.1 Captive Fasteners

[HS10026] The system should provide captive fasteners for maintenance activities.

Rationale: Captive fasteners for maintenance tasks prevent loss of fasteners. Dropped fasteners could become Foreign Object Debris, which could pose a risk during launch. This could cause injury, impact launch schedule, or damage equipment.

Revision: E	Document No: CxP 70024
Release Date: 11/19/10	Page: 159 of 503
Title: Constellation Program Human-Systems Integration Requirements	

3.9.7.4 Tools

3.9.7.4.1 Toolset

[HS10028] The system shall be assembled and maintained using only those tools identified in the Launch Site Task Tool List <TBD-70024-050>.

Rationale: Using a standard tool set for all equipment eliminates the proliferation of unique tools and reduces the training and support requirements for the ground crews. Specialty tools require special logistics tracking (which adds to operations costs) and could become lost, postponing maintenance and requiring replacement at a high cost per unit.

3.9.7.4.2 Tool Clearances

[HS10024] The system shall provide tool clearances for tool installation and actuation for all tool interfaces during ground maintenance.

Rationale: Tool use for assembly and maintenance tasks must be considered as a design activity. The tool to be used must be identified by the hardware developer, and clearance for its application must be accommodated. The design of all tools that may be applicable (e.g., wrenches, torque multipliers, bales [on connectors]), should take into consideration the application of the tool.

3.9.7.5 Fuse/Circuit Indication

3.9.7.5.1 Fuse/Circuit Indication

[HS10010] The system shall provide indication to the ground crew when a fuse or circuit breaker has opened a circuit.

Rationale: If a circuit has a protection device (e.g., fuse or circuit breaker), the potential exists that the device will need to be replaced or reset by the ground crew. To facilitate these tasks, these devices must provide an indication of their state to the ground crew.

3.9.7.6 Access

3.9.7.6.1 Maintainability Without Deintegration

[HS10001] The system shall not require deintegration or de-mating of previously tested and certified interfaces during corrective and preventive maintenance.

Rationale: The integrated design of the vehicle must be such that the ground crew is able to maintain the components (subsystems and Elements) in the integrated vehicle state and orientation. The intent is to preclude deintegration of the Elements or their subsystems during or after vehicle assembly. Such deintegration would constitute an extremely expensive and recurring addition to ground operating costs. This can only be accomplished through integrated design so that the design of one subsystem (e.g., Ares I: First Stage) does not

Revision: E	Document No: CxP 70024
Release Date: 11/19/10	Page: 160 of 503
Title: Constellation Program Human-Systems Integration Requirements	

force deintegration of the subsystem it is mated to (Ares I: Second Stage) in order to perform maintenance on the integrated vehicle. In this case, corrective maintenance activities include only those associated with LRU removal and replacement. This requirement does not apply to unplanned repair at the launch site, build activities at the manufacturing site, or potential build up before system integration.

3.9.7.6.2 Maintainability Without Disabling Subsystems

[HS10009] The system should not require the disabling of subsystems that are not directly part of the maintenance activity during launch site corrective and preventive maintenance.

Rationale: All maintenance worksites must be designed such that removal and replacement do not disable a functional, certified, and fully-tested component or system. Such disabling of a certified system results in costly retest and recertification, resulting in a larger launch site processing workforce. In this case, corrective maintenance activities include only those associated with LRU removal and replacement. This requirement does not apply to unplanned repair at the launch site, build activities at the manufacturing site, or potential build up before system integration.

3.9.7.6.3 Appropriate Clothing and Equipment

[HS10011] The system shall provide for launch site processing and corrective and preventive maintenance by personnel wearing clothing and equipment appropriate to the environment during assembly and maintenance tasks.

Rationale: The flight system components/subsystems (e.g., Ares I stages and Orion SM and CM) must be able to be assembled and maintained by the ground crew with sufficient work envelope and other accommodation to accomplish tasks under the constraints demanded by the task. The constraints for some tasks will include the use of protective equipment. This protective equipment (e.g., SCAPE suits) may be bulky, which must be accommodated in the design. In this case, corrective maintenance activities include only those associated with LRU removal and replacement. This requirement does not apply to unplanned repair at the launch site, build activities at the manufacturing site, or potential build up before system integration.

3.9.7.6.4 Inspection Access

[HS10025] Vehicle components that require inspection shall be accessible during launch site processing.

Rationale: Access must be designed for because it is required for inspection.

Revision: E	Document No: CxP 70024
Release Date: 11/19/10	Page: 161 of 503
Title: Constellation Program Human-Systems Integration Requirements	

3.9.7.6.5 Cable Access

[HS8011] The system shall provide access to cables for scheduled inspections and maintenance during ground operations.

Rationale: Access to cables is required to ensure that ground personnel can see and reach cables for inspection and maintenance activities.

3.9.7.6.6 External Service Points

[HS8013] External service points for launch pad operations shall be located within 60 degrees, radially, of the plane between the vehicle and the service structure.

Rationale: The intent of this requirement is to ensure that vehicle systems that require late servicing at the launch pad (e.g., filling, draining, purging, bleeding, etc.) can be serviced from the main pad structure without the need for additional service structures or high-risk human tasks. This is a requirement on vehicle design that service points be oriented toward the service structure. Examples of service points are those used for filling, draining, purging, or bleeding.

3.9.7.6.7 Visual Line of Sight

[HS8048] The system should provide direct line-of-sight visual access to all equipment, except blind-mate connectors, on which maintenance is performed by ground personnel, including maintenance that requires the use of PPE.

Rationale: Direct line-of-site visual access reduces the likelihood of human error that can occur when blind (by feel) operations or operations requiring the use of specialized tools (e.g., mirrors or bore scopes) are performed. PPE may be required for certain maintenance activities and must be accommodated. Direct line of sight for pin inspection is not required, though it is desired where possible. A blind-mate connector is one that is automatically de-mated and mated as a piece of equipment is removed and replaced.

3.9.7.7 Damage/Hazard Controls

3.9.7.7.1 Maintenance Without Damage

[HS10019] The system shall allow corrective and preventive maintenance without damaging other components.

Rationale: Deintegration of certified flight components will require costly recertification if disturbed. This requirement is intended to limit such recertification. The intent is to maintain a flight configuration for systems that are not part of the maintenance. In this case, corrective maintenance activities include only those associated with LRU removal and replacement. This requirement does not apply to unplanned repair at the launch site, build activities at the manufacturing site, or potential build up before system integration.

Revision: E	Document No: CxP 70024
Release Date: 11/19/10	Page: 162 of 503
Title: Constellation Program Human-Systems Integration Requirements	

3.9.7.7.2 Fluid Management

[HS10020] The system shall provide a method for isolating, draining, or venting fluids for subsystems that contain pressurized fluids during launch site processing and ground maintenance.

Rationale: Isolation or disconnect valves are needed to permit isolation and servicing and to aid in leak detection. These valves will also prevent spillage and release of fluids during removal or replacement. For enclosed systems that do not contain isolation or disconnect valves, a provision to drain fluids or vent gases is needed. The term fluids refers to both liquids and gases in the context of this requirement.

3.9.7.7.3 Fluid Spillage Control

[HS10021] The system shall control spillage and the release of fluids during launch site processing.

Rationale: Elements or systems must provide methods for controlling liquid and gas spills during ground assembly and maintenance activities.

3.9.7.7.4 System Safing Controls

[HS10022] The system shall provide controls that allow ground personnel to safe the system prior to performing maintenance.

Rationale: Elements or systems must provide methods for system safing during ground assembly and maintenance activities. Controls may include cut-out switches, warning placards, guards, etc.

3.9.7.7.5 Equipment Protection

[HS10023] System hardware should be designed to prevent loss of form, fit, and function due to planned handling and servicing operations during launch site processing tasks.

Rationale: Components and LRUs that are susceptible to damage during assembly or maintenance activities should be protected from ground crew activities, taking into consideration the use of platforms, tethering devices, Personal Protective Equipment, and other tools. Structural elements that might be utilized as supports should be either designed to support ground crew-induced loads or protected in some manner. This includes protrusions that resemble handles or steps that are not designed to be handles or steps. Use of such protrusions to support either the hardware or the ground crew represents a hazard to both the equipment and personnel. If the hardware cannot be protected through hardware design due to weight, space, or cost concerns, the use of removable GSE that protects the flight hardware and surrounding structure can be used. The cost associated with this method is increased

Revision: E	Document No: CxP 70024
Release Date: 11/19/10	Page: 163 of 503
Title: Constellation Program Human-Systems Integration Requirements	

processing complexity, which could lead to FOD, longer processing times, and overhead in tracking the removable GSE.

3.9.7.7.6 Safety Displays

[HS10029] The system shall provide displays that are within the field of view of the launch site personnel performing the task when the task could result in a hazard if not viewed directly.

Rationale: When performance of assembly or maintenance tasks requires that feedback be provided to the ground crew (e.g., bolt torque of a critical component), the ground crew must have clear view of the display. Absence of such access to displays could result in a hazard to the ground personnel or hardware.

3.9.7.7.7 Protrusion Label/Support

[HS10043] The system shall design all accessible protrusions that could be inadvertently used as handles, steps, handrails, or mobility aids to either support the weight of personnel or clearly label them as keep-out zones.

Rationale: Historical experience with Shuttle and Station has shown that it is important to make it clear which parts of a vehicle may not be used as handles, steps, or handrails so that as ground and flight crews move around the vehicle they do not inadvertently damage delicate portions of the vehicle. Preference should be given to designing to support in areas where ground and flight crews will travel frequently.

3.9.8 Ground Information Management

<Reserved>

3.10 EXTRAVEHICULAR ACTIVITY (EVA)

This section contains requirements that define the needs and limitations of the human that are considered during design of Constellation Systems that support suited operations.

3.10.1 Suit Atmosphere

3.10.1.1 Suit Pressure

3.10.1.1.1 Suit Pressure Set-Point Selection

[HS11000] The system shall provide the capability for the crew to select discrete suit pressure set-points within the suit operating pressure ranges.

Rationale: To implement the operational concepts possible in a variable pressure suit, the crew must be able to select the desired discrete pressure setting. In order to alleviate initial symptoms of DCS, the crew will need to select a suit pressure of 8 psia. However, lower pressures optimize the work efficiency

Revision: E	Document No: CxP 70024
Release Date: 11/19/10	Page: 164 of 503
Title: Constellation Program Human-Systems Integration Requirements	

of the pressurized suited crew. For efficient workload, the crew needs to be able to select a minimum operating pressure. In the case of an unrecoverable vehicle pressure failure lasting up to 144 hours where the crew is not able to prebreathe before operating in a pressurized suit, the crew will need to be able to select 8 psia to mitigate the risk of DCS, followed by the ability to select a mid-range suit operating pressure to allow for more mobility to operate the vehicle. During umbilical use, the suit depends on the vehicle to provide life support. Vehicle life support systems are adjustable by both flight and ground crew as specified in HS3001.

3.10.1.1.2 Maintain Suit Pressure Set-Point

[HS11019] The system shall maintain each individual suit pressure within 0.1 psi after that suit has achieved an equilibrium pressure for a set point.

Rationale: Maintaining a constant pressure level after a set point has been reached is important to protect the crew from discomfort in body cavities and sinuses, especially in the ear. Human tolerance of pressure changes can be found in HS3009. Maintaining a constant pressure level is intended to protect the crew in the pressurized suit as well as in the habitable volume of the vehicle. It is planned to expose the crew to pressure changes during suited operations in order to accomplish safe EVA operations. Because of these nominal pressure changes and the relatively small total pressure volume in the suit, it is important that the pressurized suited crewmember is exposed to a pressure set-point that is constant (unchanging). Excess fluctuations in suit pressure will cause pressurized suited crewmembers to constantly re-equilibrate pressure in body cavities and sinuses, which will increase the likelihood of pressure induced discomfort in these areas. During umbilical use, the suit depends on the vehicle to provide life support.

3.10.1.1.3 Suit Pressure Pause

[HS11001] The system shall allow the suited crew to stop and restart suit pressure increases.

Rationale: Pressure changes during suited operations can result in barotrauma to the crewmember if adequate time is not allowed for anatomical compartmental pressure equalization, e.g., sinuses or middle ear cavity. The ability to stop pressure changes will allow the crewmember to equalize body cavity pressures. During umbilical use, the suit depends on the vehicle to provide life support. This requirement is not intended to allow the crewmember to stop emergency pressurization processes.

Revision: E	Document No: CxP 70024
Release Date: 11/19/10	Page: 165 of 503
Title: Constellation Program Human-Systems Integration Requirements	

3.10.1.2 Thermal Environment for the Suited Crewmember

3.10.1.2.1 Control of Heat Stored by Crewmembers during EVA and Pre-launch Operations

[HS11002] The system shall prevent the energy stored by each crewmember during EVA operations from exceeding the limits defined by the range: 3.0 kJ/kg (1.3 BTU/lb) > ΔQ stored > -1.9 kJ/kg (-0.8 BTU/lb), where ΔQ stored is calculated using the 41-Node man or Wissler model.

Rationale: This requirement applies to nominal microgravity EVA operations, nominal surface EVA operations, and pre-launch operations. Heat stored by crewmembers during launch, landing, and off-nominal suited operations is covered in HS3037. Calculation of heat storage or rejection (ΔQ stored) is per 41-Node man or Wissler model. The ΔQ stored equation is plotted in Appendix E, figure Heat Storage, to graphically show the boundaries of the human heat accumulation or rejection tolerance. Heat accumulation excess heat load may quickly reach crew tolerance limits and may impair crew performance and health. Crew impairment begins when skin temperature increases greater than 1.4 °C (2.5 °F) (0.6 °C [1 °F] core) or if pulse is greater than 140 bpm. Appendix E, table Core Temperature Range Limits and Associated Performance Decrements, identifies core temperature range limits and associated performance decrements. Keeping the crewmember heat storage value below the performance impairment line allows the crew the ability to conduct complex tasks without heat-induced degradation. If the crewmember is in a suit, the heat load may increase rapidly. JSC thermoregulatory models (Wissler and 41-Node man) simulating hot cabin entries wearing launch and entry suits with the properties of the Advanced Crew Escape Suit (ACES) (thickness, conductance, wickability, emissivity) predicted loss of all body cooling mechanisms. Supporting data from military aircrew protective ensembles suggest body temperature may increase more rapidly over time in ACES compared to a shirt-sleeve environment. The current change in heat storage limit should allow nominal suited operations with crewmember metabolic rates of 528 to 2,220 kJ/hr (500 to 2,100 BTU/hr) without undue heat discomfort. Heat rejection rationale: If heat is removed from the body to the point of thermogenic shivering, crew task performance will be impaired in a similar fashion to excess heat storage. Like the condition of excess heat storage, which can be mitigated by specialized cooling garments, excess heat rejection can be mitigated to some degree by the use of insulating garments. Appendix E, figure Environmental Comfort Zone shows the effect of tolerance to cold temperature and wind by the addition of varying degrees of thermal protecting clothing. Keeping the crewmember heat rejection value above the performance impairment line shown in Appendix E, figure Heat Storage allows the crew to conduct tasks without cold induced degradation. During umbilical use, the suit depends on the vehicle to provide life support.

Revision: E	Document No: CxP 70024
Release Date: 11/19/10	Page: 166 of 503
Title: Constellation Program Human-Systems Integration Requirements	

3.10.1.2.2 Crew Accessibility to Suit Temperature Controls

[HS11022] Independent suit temperature set-point control shall be accessible by each suited crewmember during all nominal operations, including times when the crew is restrained.

Rationale: Each suited crewmember will need to control and adjust their individual suit temperature during all flight phases to ensure crew comfort for mission success.

3.10.1.3 Deleted

3.10.1.4 Radiation Monitoring for Suited Crewmembers

3.10.1.4.1 Suited Radiation Dose Equivalent Monitoring

[HS11023] The system shall provide an omnidirectional detector that can continuously measure and record the dose equivalent from charged particles with Linear Energy Transfer (LET) 0.2 to 300 keV/micrometer, as a function of time, at two shielding depths: 0.5 g cm⁻² water equivalent and 3.0 g cm⁻² water equivalent.

Rationale: The absorbed dose/dose equivalent instrument will be the primary instrument for controlling crew exposure during EVA. The current exposure limit quantity for deterministic effects (short-term exposure limits) requires the determination of absorbed dose in depth. The range of linear energy transfer of 0.2 to 300 keV/μm includes the broad range expected from primary and secondary radiation of solar particle events. It is expected that this requirement and the absorbed dose monitoring requirement will be met by the same instrument.

3.10.1.4.2 Suited Radiation Absorbed Dose Monitoring

[HS11024] The system shall provide an omnidirectional detector that can continuously measure and record the absorbed dose from charged particles with Linear Energy Transfer (LET) 0.2 to 300 keV/micrometer, as a function of time, at two shielding depths: 0.5 g cm⁻² water equivalent and 3.0 g cm⁻² water equivalent.

Rationale: The absorbed dose/dose equivalent instrument will be the primary instrument for controlling crew exposure during EVA. The current exposure limit quantity for deterministic effects (short-term exposure limits) requires the determination of absorbed dose in depth. The range of linear energy transfer of 0.2 to 300 keV/μm includes the broad range expected from primary and secondary radiation of solar particle events. It is expected that this requirement and the dose equivalent monitoring requirement will be met by the same instrument.

Revision: E	Document No: CxP 70024
Release Date: 11/19/10	Page: 167 of 503
Title: Constellation Program Human-Systems Integration Requirements	

3.10.1.4.3 Stowage for Suit Dosimeters

[HS11004] The system shall provide a stowage location for a removable personal passive dosimeter that is external to the crewmember's body and internal to the pressurized volume of the suit (excluding helmet, gloves, and boots).

Rationale: A personal passive dosimeter is required by the Code of Federal Regulations (CFR) and the Occupational Safety and Health Administration (OSHA) for monitoring astronaut radiation exposure. Providing a stowage location on the Liquid Cooling and Ventilation Garment (LCVG), for example, will minimize crew overhead to don and doff this hardware. The standard passive dosimeters used for ISS/Shuttle/Mir by US and Russian scientists are installed inside the pressurized part of the suit. Placing dosimeters inside the pressurized suit allows for appropriate selection of shielding location that is representative of the skin dose/organ dose that the crewmember is receiving. Current state of the art dosimeters used by US scientists require a presence of oxygen to function properly.

3.10.2 Suited Visibility

3.10.2.1 Visual Field of View for a Suited Crewmember

[HS11005] The system shall provide a suit with an external, visual field of view to perform suited IVA and EVA operations.

Rationale: To enhance work efficiency index and mission success, the visor must have minimal interference with nominal visual acuity. The visor should promote an adequate visual field of view to perform ground, IVA, and EVA tasks and prevent tunnel vision.

3.10.2.2 Optical Quality for Suited Crewmembers

[HS11006] The system shall provide optical quality to perform suited tasks.

Rationale: To enhance work efficiency index and mission success, the visor must have minimal interference with nominal visual acuity. The visor should minimize haze, discoloration, and fog. The optical properties of the helmet visor will be controlled via specifications for that end item.

3.10.3 Crew Functions for the Suited Crewmember

3.10.3.1 Nutrition for Suited Crewmembers

3.10.3.1.1 In-Suit Nutrition During Surface EVA Operations

[HS11007] As specified in HS6062, the system shall provide the capability for nutrition consumption while a crewmember is performing surface EVA operations.

Rationale: During a surface EVA, crewmembers will most likely be suited for 10 hours with approximately 7 of those hours on the surface expending energy.

Revision: E	Document No: CxP 70024
Release Date: 11/19/10	Page: 168 of 503
Title: Constellation Program Human-Systems Integration Requirements	

Nutritional supply during suited operations will allow the crewmembers to maintain high performance levels throughout the duration of the EVA. Apollo summit strongly recommended the availability of a high energy substance, either liquid or solid, for consumption during a surface EVA. This capability is not required during contingency microgravity EVAs and/or for EVAs less than 4 hours in duration.

3.10.3.1.2 In-Suit Nutrition During Unpressurized Vehicle Survival

[HS11008] As specified in HS6062, the system shall provide the capability for nutrition consumption by a crewmember in a pressurized suit during unpressurized vehicle survival operations.

Rationale: During long-duration suited operations, such as an unplanned pressure reduction scenario, the crew will need to consume nutrition from an external source to maintain crew performance. This requirement addresses delivery of nutrition to the crew during extended contingency use of pressure suits. The nutrition in contingency cases such as unplanned cabin depressurization could be delivered via a hydration drink port similar to that used in Apollo and could consist of a low-residue substance.

3.10.3.2 Hydration for Suited Crewmembers

3.10.3.2.1 In-Suit Hydration During EVA

[HS11009] As specified in HS6063, the system shall provide the capability for water consumption by a crewmember in a pressurized suit during EVA operations longer than 4 hours.

Rationale: During a lunar EVA, crewmembers will most likely be suited for 10 hours with approximately 7 of those hours expending energy on the lunar surface. Potable water is necessary during suited operations to prevent dehydration due to insensible water loss and to improve crew comfort. Apollo summit strongly recommended the availability of 8 ounces of water per hour for consumption during a lunar EVA with water available for contingency scenarios, such as a 10-km walk-back in case of rover failure. The intent of this requirement is to allow the crew to have "instant" (less than 2 seconds) access to potable water at their discretion. Having the potable water system be rechargeable from an external source is acceptable as long as the internal suit reservoir is sufficient capacity to allow ready access to water without impacting work efficiency.

3.10.3.2.2 In-Suit Hydration during IVA

[HS11010] The system shall provide the capability for water consumption by a crewmember in a pressurized suit during suited intravehicular operations.

Rationale: During long duration suited operations, such as an unplanned pressure reduction scenario, the crew will need to consume water from an

Revision: E	Document No: CxP 70024
Release Date: 11/19/10	Page: 169 of 503
Title: Constellation Program Human-Systems Integration Requirements	

external source to prevent crew performance degradation associated with dehydration.

3.10.3.3 Waste Management

3.10.3.3.1 Vomitus in the Suit

[HS11011] The system should provide for isolation of the crewmember from vomiting events of 0.5 L each as indicated in HS6013, table Vomitus Collection and Containment.

Rationale: Space Adaptation Syndrome has affected crewmembers in the first 72 hours of flight. The crew is nominally suited during the first 72 hours of flight for certain dynamic phases; vomiting in the suit may occur at these times or if a contingency EVA occurs within that time frame. On the planetary surface, a high magnitude Solar Particle Event (SPE) could result in exposures that produce prodromal nausea and vomiting. If vomitus enters the internal suit environment, ideally it should be kept away from the suited crewmember's naso-pharyngeal space.

3.10.3.3.2 Nominal Urine Collection in the Suit

[HS11012] The system shall collect and contain 500 mL + 2t/24 L of urine, where t is suited duration in hours.

Rationale: This requirement allows crewmembers to eliminate liquid waste at their discretion without affecting work efficiency during suited operations. The suit will only be responsible for the expected urinary output during the time that the crewmember is in the suit. The expected daily urine output is 2 L per day. The minimum for a single void is 500 mL, and 2t/24 protects for a second void while suited. Nominal urine output should not be accounted for during an unrecoverable vehicle pressure failure lasting up to 144 hours.

3.10.3.3.3 Urine Collection - Suited Contingency

[HS11013] The system shall collect and contain 1 L per day per crewmember of urine during an unrecoverable vehicle pressure failure.

Rationale: In the event of an unrecoverable vehicle pressure failure, the crewmembers will have to remain suited for up to 144 hours without having the capability to access the fecal and urine collection system. The waste quantities reflect the altered composition of the nutrition supplied during contingency suited operations and are characteristically low in residue. Nominal fecal and urine output should not be accounted for during an unrecoverable vehicle pressure failure lasting up to 144 hours.

Revision: E	Document No: CxP 70024
Release Date: 11/19/10	Page: 170 of 503
Title: Constellation Program Human-Systems Integration Requirements	

3.10.3.3.4 Feces Collection - Suited Contingency

[HS11014] The system shall collect and contain 75 grams (by mass) and 75 mL (by volume) of fecal matter per crewmember per day during an unrecoverable vehicle pressure failure.

Rationale: In the event of an unrecoverable vehicle pressure failure, the crewmembers will have to remain suited for up to 144 hours without having the capability to access the fecal and urine collection system. The waste quantities reflect the altered composition of the nutrition supplied during contingency suited operations and are characteristically low in residue. Nominal fecal and urine output should not be accounted for during an unrecoverable vehicle pressure failure lasting up to 144 hours.

3.10.4 Prevention and Treatment of Decompression Sickness

3.10.4.1 Denitrogenation

[HS6091] The Constellation Architecture shall maintain the pressure and gaseous oxygen concentration for the required time durations specified per HS6091, table Prebreathe Durations for Contingency EVA and table Prebreathe Durations for Nonrecoverable Cabin Depress for denitrogenation of the crew.

TABLE 3.10.4.1-1 - PREBREATHE DURATIONS FOR CONTINGENCY EVA

	95% O2 Prebreathe Pressure kPa (psid) (mmHg)	Time (minutes) spent before suit pressure at 30 kPa (4.3 psid) (222 mmHg)
CEV to LEO		
101 kPa Saturation, 21.0% O2	101 (14.7) (760)	345
<i>60 min 95% O2 prebreathe during depress from 101 kPa to 70 kPa</i>		
0-6 Hrs at 70 kPa, 26.5% O2	70 (10.2) (528)	275
6-12 Hrs at 70 kPa, 26.5% O2	70 (10.2) (528)	195
12-18 Hrs at 70 kPa, 26.5% O2	70 (10.2) (528)	145
18-24 Hrs at 70 kPa, 26.5% O2	70 (10.2) (528)	120
24-36 Hrs at 70 kPa, 26.5% O2	70 (10.2) (528)	110
36-48 Hrs at 70 kPa, 26.5% O2	70 (10.2) (528)	100
48-78 Hrs at 70 kPa, 26.5% O2	70 (10.2) (528)	95
78+ Hrs at 70 kPa, 26.5% O2	70 (10.2) (528)	95
Lunar Coast CEV/LSAM docked		
70 kPa Saturation, 26.5% O2	70 (10.2) (528)	95
LSAM undocked from CEV		
70 kPa Saturation, 26.5% O2	70 (10.2) (528)	95
0-6 Hrs at 55 kPa, 32.0% O2	55 (8.0) (414)	95
6-12 Hrs at 55 kPa, 32.0% O2	55 (8.0) (414)	15
12+Hrs at 55 kPa, 32.0% O2	55 (8.0) (414)	0
55 kPa Saturation, 32.0% O2	55 (8.0) (414)	0
Earth return CEV		
70 kPa Saturation, 26.5% O2	70 (10.2) (528)	95

Notes / Assumptions:

Revision: E	Document No: CxP 70024
Release Date: 11/19/10	Page: 171 of 503
Title: Constellation Program Human-Systems Integration Requirements	

1. Prebreathe durations based on Tissue Bubble Dynamics Model regression with NASA Bends 1-7 and DCS risk $\leq 15\%$ Model: 360MGMB0MCB1-7_120707 (BGI $\leq 34.9 =$ DCS $\leq 15\%$).
2. Prebreathe durations do not include depress times from prebreathe pressure to EVA suit pressure.
3. Prebreathe durations assume 0.74PSI/min depress rates on 95% O2 from prebreathe pressure to suit pressure, except for 14.7 -10.2 PSI depress, for which a 15 minute depress on 95% O2 is assumed.
4. Prebreathe performed prior to a nominal 101 - 70 kPa depress is performed entirely at starting saturation pressure.
5. Prebreathe durations subsequent to nominal 101 - 70 kPa depress assume on mask at 95% O2 during 60 min depress from 101 kPa to 70 kPa (45 mins at 101 kPa, 15 minute depress from 101 - 70 kPa, all on 95% O2).
6. Prebreathe times are not applicable to surface EVAs.
7. Prebreathe is assumed to begin after 95% O2 has been achieved; and 95% O2 concentration maintained throughout the entire prebreathe duration.
8. Deviations from stated assumptions may affect prebreathe durations.
9. Contingency EVA prebreathe durations based on 6hr EVA, 95% O2 (4 hr planned, could go longer so conservatively use 6 hrs as we do for shuttle and ISS ops).
10. Assume minimum 18hrs at 70 kPa 26.5% O2 (CEV) or 55 kPa 32% O2 (LSAM) between 6 hr EVAs by same crewmember.

TABLE 3.10.4.1-2 - PREBREATHE DURATIONS FOR NON-RECOVERABLE CABIN DEPRESS

	Time (minutes) spent at 41 kPa (6.0 psid) (310 mmHg), 95% O2 during first hour post-depress (1st pop-down)	Time (minutes) spent at 41 kPa (6.0 psid) (310 mmHg), 95% O2 during second hour post-depress (2nd pop-down)	Maximum stay at 41 kPa (6.0 psid) (310 mmHg) with DCS risk ≤ 15%:	Total time (minutes) since cabin depress before indefinite stay at 29 kPa (4.3 psid) (222 mmHg)
CEV to LEO				
101 kPa Saturation, 21.0% O2	0	0		580
	0	15		595
	15	0		595
	15	15		610
				215
<i>60 min 95% O2 prebreathe during depress from 101 kPa to 70 kPa.</i>				
0-6 Hrs at 70 kPa, 26.5% O2	0	0		455
	0	15		470
	15	0		475
	15	15		490
			290	655
6-12 Hrs at 70 kPa, 26.5% O2	0	0		270
	0	15		290
	15	0		305
	15	15		320
			635	635
12-18 Hrs at 70 kPa, 26.5% O2	0	0		185
	0	15		185
	15	0		215
	15	15		235
			460	460
18-36 Hrs at 70 kPa, 26.5% O2	0	0		160
	0	15		160
	15	0		160
	15	15		185
			375	375
36-48 Hrs at 70 kPa, 26.5% O2	0	0		140
	0	15		140
	15	0		140
	15	15		140
			305	305
48+ Hrs at 70 kPa, 26.5% O2	0	0		135
	0	15		135
	15	0		135
	15	15		135
			295	295
Lunar Coast CEV/LSAM docked				
70 kPa Saturation, 26.5% O2	0	0		135
	0	15		135
	15	0		135
	15	15		135
			295	295
LSAM undocked from CEV				
70 kPa Saturation, 26.5% O2	0	0		135
	0	15		135
	15	0		135
	15	15		135
			295	295
0-6 Hrs at 55 kPa, 32.0% O2	0	0		140
	0	15		140
	15	0		140
	15	15		140
			300	300
6-12 Hrs at 55 kPa, 32.0% O2	0			60
	15			55
			55	55
12+ Hrs at 55 kPa, 32.0% O2				0
65 kPa Saturation, 32.0% O2				0
Earth return CEV				
70 kPa Saturation, 26.5% O2	0	0		135
	0	15		135
	15	0		135
	15	15		135
			295	295

Revision: E	Document No: CxP 70024
Release Date: 11/19/10	Page: 173 of 503
Title: Constellation Program Human-Systems Integration Requirements	

Notes / Assumptions:

1. Prebreathe durations based on Tissue Bubble Dynamics Model regression with NASA Bends 1-7 and DCS risk $\leq 15\%$ Model: 360MGMB0MCB1-7_120707 (BGI $\leq 34.9 =$ DCS $\leq 15\%$).
2. Prebreathe durations do not include depress times from nominal cabin pressure to prebreathe pressure and from prebreathe pressure to EVA suit pressure.
3. Prebreathe durations assume 0.74PSI/min depress rates on 95% O2 from prebreathe pressure to suit pressure, except for 14.7 -10.2 PSI depress, for which a 15 minute depress on 95% O2 is assumed.
4. Prebreathe performed prior to a nominal 101 - 70 kPa depress is performed entirely at starting saturation pressure.
5. Prebreathe durations subsequent to nominal 101 - 70 kPa depress assume on mask at 95% O2 during 60 min depress from 101 kPa to 70 kPa (45 mins at 101 kPa, 15 minute depress from 101 - 70 kPa, all on 95% O2).
6. Contingency cabin depressurization scenario assumes immediate depress (at 0.74PSI/min) from previous cabin pressure to 55 kPa (i.e. no prebreathe performed before depress to 55 kPa). Listed prebreathe performed at 55 kPa. The capability to perform at least some prebreathe before depress to 55 kPa would reduce prebreathe times in some instances but that capability was not assumed.
7. Prebreathe durations during cabin depressurizations assume repress on 95% O2 from 41 kPa (6 psid) to 55 kPa (8 psid) following 15 minute pop-downs. 15 minute pop-downs do not include depress and repress time i.e. they include 15 minutes at 41 kPa.
8. Prebreathe times are not applicable to surface EVAs.
9. Prebreathe is assumed to begin after 95% O2 has been achieved; and 95% O2 concentration maintained throughout the entire prebreathe duration.
10. Deviations from stated assumptions may affect prebreathe durations.
11. Prebreathe durations based on 120+ hr contingency suited operations, 95% O2.

Rationale: Standardization of nitrogen washout (prebreathe) will reduce the risk of decompression sickness to within acceptable limits during reduced pressure operations. HS6091, table Prebreathe Durations for Contingency EVA and table Prebreathe Durations for Nonrecoverable Cabin Depress were developed to calculate total crewmember prebreathe durations during various Design Reference Missions (DRMs). The duration of the required prebreathes vary with pressure and oxygen concentration levels. These values have been placed in the requirement as design drivers for the system architecture, such as tank size. Several notes and assumptions were considered when calculating these values. These notes and assumptions can be found in HS6091, table Prebreathe Durations for Contingency EVA and table Prebreathe Durations for Nonrecoverable Cabin Depress. This requirement will be met by integrated systems with the details of each system's responsibility in individual system SRDs and in IRDs. For the nonrecoverable cabin depressurization scenario HS6091, table Prebreathe Durations for Nonrecoverable Cabin Depress, it is assumed that prebreathe is performed at 55 kPa (8.0 psid) (414 mmHg). However, the reduced mobility that is allowed by the suit at 55 kPa may preclude the performance of critical tasks immediately following the depressurization event. In recognition of this determination, scenarios were also modeled wherein suit pressure was dropped to 41 kPa (6.0 psid) (310 mmHg) for 15 minutes during the first and/or second hour post-depress (referred to as "pop-downs"). In all cases, the total time required after cabin depressurization before crewmembers can remain at 30 kPa (4.3 psid) (222.4 mmHg) is also shown. Also shown is the maximum time that could be spent at 41 kPa (6.0 psid) immediately following a depressurization while still remaining within the 15%

Revision: E	Document No: CxP 70024
Release Date: 11/19/10	Page: 174 of 503
Title: Constellation Program Human-Systems Integration Requirements	

DCS risk. In some such cases, it is necessary to return to 55 kPa (8.0 psid) for additional prebreathe after spending the maximum possible time at 41 kPa (6.0 sid), while in other cases it is possible to depress from 41 kPa (6.0 psid) directly to 30 kPa (4.3 psid) (indicated where the "maximum stay at 41 kPa [6.0 sid] [310 mmHg] with DCS risk ≤15%" is the same as the "total time since cabin depress before indefinite stay at 30 kPa"). Prebreathe durations were estimated using a physics-based Tissue Bubble Dynamics Model (TBDM) that provides a time-varying index of theoretical physiological decompression stress given inputs of the variations in pressure and gas composition during various Design Reference Mission (DRM) scenarios. A $BGI \leq 34.9 = DCS \leq 15\%$ was used in these calculations to protect the crewmember from a Type II DCS hit. A $BGI \leq 34.9 = DCS \leq 15\%$ is the threshold at which no Type II DCS hit has been observed in the past. Additional information on the TBDM can be found in CAIT IDA4 SIG-05-1034 Denitrogenation and Decompression Sickness (DCS) TDS.

3.10.4.2 DCS Event Pressure

[HS6100] The Constellation Architecture shall provide a minimum crewmember initial saturation pressure to a DCS-affected crewmember within 20 minutes of a DCS event.

Rationale: DCS is a potential hazard of space flight and EVA due to changes in the operational pressure environment. Rapid and appropriate intervention is required to optimize the outcome for the affected crewmember. If treatment for DCS is instituted within 20 minutes of onset of symptoms, then the outcome of therapy has a higher probability of success and will likely require less magnitude and duration of hyperbaric oxygen therapy. The requirement is, therefore, to have the crewmember back to their initial saturation pressure within 20 minutes, which may resolve DCS symptoms. Initial saturation pressure is defined as the highest pressure to which the crewmember has been exposed during the 36 ours prior to beginning the EVA. Beyond 20 minutes, higher pressures may be required to address DCS symptoms. The US Navy Treatment, Table 6 (treatment in a hyperbaric treatment facility) is the terrestrial standard for treating most forms of DCS; however, the terrestrial standard will not be achievable, or required, because the resource required to support it would be prohibitive and the expected outcomes from sub-terrestrial standard therapy are likely to be adequate for "altitude-induced" DCS symptoms. Instead of a multi-place hyperbaric chamber, treatment vessels for the delivery of space DCS treatment may include pressure suits, airlocks, and vehicle habitable volumes, which may be used independently or in combination to achieve specified pressures and enriched/hyperbaric oxygen treatment. The treatment plan will also include specific diagnostic and therapeutic procedures based on the severity of DCS symptoms observed and may include fluids (intravenous or oral), anti-inflammatory medications, etc, and/or guidance for decisions on return contingencies and plans for terrestrial response after deorbit of the crewmembers with DCS.

Revision: E	Document No: CxP 70024
Release Date: 11/19/10	Page: 175 of 503
Title: Constellation Program Human-Systems Integration Requirements	

3.10.4.3 DCS Over-Pressurization

[HS6081] The system shall provide a pressure of 156.5 kPa (22.7 psia) (1,174 mmHg) to a DCS-affected crewmember, within 2 hours of a DCS event, for a minimum of 6 hours.

Rationale: DCS is a potential hazard of space flight and EVA due to changes in the operational pressure environment. Following initial treatment of DCS symptoms with hyperoxic pressure, it is usually necessary to provide follow-on treatment with higher levels of pressure for treatment of unresolved or recurrent DCS symptoms or prevention of recurrent symptoms. In order to prevent progression of DCS symptoms or the development of DCS-induced deficits or permanent sequelae, in cases of unresolved or recurrent DCS symptoms, it is necessary to provide prompt pressure to the crewmember, above that of the starting vehicular pressure. Rapid and appropriate intervention is required to optimize the outcome for the affected crewmembers. The US Navy Treatment, Table 6 (treatment in a hyperbaric treatment facility) is the terrestrial standard for treating most forms of DCS; however, the terrestrial standard will not be achievable, or required, because the resources required to support it would be prohibitive and the expected outcomes from sub-terrestrial standard therapy are likely to be adequate for "altitude-induced" DCS symptoms. Instead, treatment vessels for the delivery of hyperbaric oxygen may include pressure suits, airlocks, and vehicle habitable volumes, which may be used independently or in combination to achieve specified pressures. The pressure 156.5 kPa (22.7 psia) (1174 mmHg) is chosen to match current DCS treatment capability on the ISS consisting of 101.4 kPa (14.7 psia) (760 mmHg) vehicular +55.2 kPa (8.0 psia) (413 mmHg) -57.2 kPa (8.3 psia) (429 mmHg) Extravehicular Mobility Unit (EMU) suit pressure when operating the Bends Treatment Apparatus. The DCS treatment pressure may be achieved by a combination of pressure vessels to include maximal vehicular or airlock pressure + maximal suit pressure. If the assumption of maximal operating lunar pressure is 72.4 kPa (10.5 psia) (543 mmHg) + suit is 56.5 kPa (8.2 psia) (424 mmHg), then the airlock or portable chamber would need to provide an additional 27.6 kPa (4 psia) (207 mmHg) of pressure to meet this requirement. The treatment plan will also include specific diagnostic and therapeutic procedures including guidance for decisions on return contingencies and plans for terrestrial response return of the crewmembers with DCS, if return is required based on incomplete response to treatment. Late onset or severe DCS requires higher pressures to treat but should still be administered as quickly as possible following the onset of symptoms for maximum effectiveness. For the scenario when the vehicle cannot maintain pressure such as the uncontrolled cabin depressurization contingency (120-hour), then 156.5 kPa (22.7 psia) (1,174 mmHg) DCS treatment pressure will not be obtainable. In this case, the architecture must provide a minimum of 55.2 kPa (8 psia) (413 mmHg) greater than ambient pressure for a minimum of 6 hours.

3.10.5 Data for Physiological Parameters

3.10.5.1 Measurement of Physiological Parameters

[HS11015] The Constellation Architecture shall measure physiological parameters for suited operations as shown in HS11015, table Measurement of Physiological Parameters.

TABLE 3.10.5.1-1 - MEASUREMENT OF PHYSIOLOGICAL PARAMETERS

Suit Parameter	Unpressurized and Ventilation Pressure Operations	Pressurized Operations	Lunar Surface Operations
Breathing gas flow rate (real-time)	X	X	X
ppO ₂	X	X	
Oxygen consumption rate (real-time)			X
Suit pressure (real-time)		X	X
ppCO ₂ (real-time)		X	X
Consumables (power, oxygen, water, etc., real-time)	X	X	X
Thermal loading to each EVA crewmember (calculated)			X
Heart rate (real-time)		X	X
Metabolic Rate (calculated)			X
Radiation Exposure Data			X
Notes:			
<ul style="list-style-type: none"> For suited operations, measure the parameters in gray on an individual suit basis. For a single gas environment, ppO₂ and total suit pressure are identical values and do not require separate sensors. Otherwise for a mixed gas environment, measure these two parameters individually. 			

Rationale: Measurement, display, and transmission of biomedical data will maximize crew resource management for EVA and minimize the risk for the crewmembers during off-nominal operations. Feedback of relevant suit atmospheric and physiologic information to the crew will allow better consumable management, improve optimization of EVA task performance, and reduce the risk of physiologic stress/injury. Measurement of physiological parameters during contingency and mission-preserving EVA, as well as during unrecoverable vehicle pressure loss, is necessary to ensure the health and safety of the crewmembers. The intent is to obtain biomedical data during suited operations with minimal crew time or effort required to don/doff the measurement hardware while maintaining crew comfort. Although core temperature monitoring is not a requirement for suited operations, the suits shall provide other markers (liquid cooling garment inlet/outlet temperatures, heart rate, O₂ consumption, and CO₂

Revision: E	Document No: CxP 70024
Release Date: 11/19/10	Page: 177 of 503
Title: Constellation Program Human-Systems Integration Requirements	

concentration) of thermal status. For a single gas environment, ppO₂ and total suit pressure are identical values and do not require separate sensors. Pressurized operations includes any microgravity EVA, DCS treatment, and unpressurized cabin IVA events. This requirement will be met by integrated systems with the details of each system's responsibility defined in individual system SRDs and in IRDs.

3.10.5.2 Display of Physiological Parameters

[HS11016] The Constellation Architecture shall display physiological parameters to the flight crew for suited operations as shown in HS11016, table Display of Physiological Parameters.

TABLE 3.10.5.2-1 - DISPLAY OF PHYSIOLOGICAL PARAMETERS

Suit Parameter	Unpressurized and Ventilation Pressure Operations	Pressurized Operations	Lunar Surface Operations
Breathing gas flow rate (real-time)	X	X	X
ppO ₂	X	X	
Oxygen consumption rate (real-time)			X
Suit pressure (real-time)		X	X
ppCO ₂ (real-time)		X	X
Consumables (power, oxygen, water, etc., real-time)	X	X	X
Thermal loading to each EVA crewmember (calculated)			X
Heart rate (real-time)			X
Metabolic Rate (calculated)			X
Radiation Exposure Data			X

Notes:

- For suited operations, measure the parameters in gray on an individual suit basis as specified in HS11015 and display them individually.
- For a single gas environment, ppO₂ and total suit pressure are identical values and do not require separate sensors. Otherwise for a mixed gas, measure these two parameters individually as specified in HS11015.
- For both unpressurized and ventilation pressure operations and pressurized operations display these parameters to the crew; however, all individual suited crewmembers are not required to view them.
- For lunar surface operations, display all parameters to the individual suited crewmember.

Revision: E	Document No: CxP 70024
Release Date: 11/19/10	Page: 178 of 503
Title: Constellation Program Human-Systems Integration Requirements	

Rationale: Feedback of relevant suit atmospheric and physiologic information to the flight crew will allow better consumable management, improve optimization of EVA task performance, and reduce the risk of physiologic stress/injury. Having insight into trends in physiological parameters and life-sustaining consumables will allow the IVA or EVA crew to act prospectively in preventing unsafe operating conditions, or responding to off-nominal scenarios. Pressurized operations includes any microgravity EVA, DCS treatment, and unpressurized cabin IVA events. This requirement will be met by integrated systems with the details of each system's responsibility defined in individual system SRDs and in IRDs.

3.10.5.3 Alert for Off-Nominal Physiological Parameters

[HS11017] The Constellation Architecture shall provide alerts to the flight crew for off-nominal physiological parameters during suited operations as shown in HS11017, table Alerting for Off-Nominal Physiological Parameters.

TABLE 3.10.5.3-1 - ALERTING FOR OFF-NOMINAL PHYSIOLOGICAL PARAMETERS

Suit Parameter	Unpressurized and Ventilation Pressure Operations	Pressurized Operations	Lunar Surface Operations
Breathing gas flow rate (real-time)		X	X
ppO ₂			
Oxygen consumption rate (real-time)			X
Suit pressure (real-time)		X	X
ppCO ₂ (real-time).		X	X
Consumables (power, oxygen, water, etc., real-time)		X	X
Thermal loading to each EVA crewmember (calculated)			X
Heart rate (real-time)			
Metabolic Rate (calculated)			X
Radiation Exposure Data			X
Notes:			
<ul style="list-style-type: none"> For suited operations, measure the parameters in gray on an individual suit basis as specified in HS11015 and alert individually. For a single gas environment, ppO₂ and total suit pressure are identical values and do not require separate sensors. Otherwise for a mixed gas environment, measure these two parameters individually as specified in HS11015. 			

Rationale: Alerting the crew as soon as relevant suit atmospheric and physiologic parameters move into the off-nominal range will allow the crew to appropriately react to off-nominal scenarios prior to development of unsafe operations. Pressurized operations includes any microgravity EVA, DCS

Revision: E	Document No: CxP 70024
Release Date: 11/19/10	Page: 179 of 503
Title: Constellation Program Human-Systems Integration Requirements	

treatment, and unpressurized cabin IVA events. This requirement will be met by integrated systems with the details of each system's responsibility defined in individual system SRDs and in IRDs.

3.10.5.4 Telemetry of Physiological Parameters

[HS11018] The Constellation Architecture shall send telemetry of physiological parameters for suited operations as shown in HS11018, table Telemetry of Physiological Parameters.

TABLE 3.10.5.4-1 - TELEMETRY OF PHYSIOLOGICAL PARAMETERS

Suit Parameter	Unpressurized and Ventilation Pressure Operations	Pressurized Operations	Lunar Surface Operations
Breathing gas flow rate (real-time)	X	X	X
ppO ₂	X	X	
Oxygen consumption rate (real-time)			X
Suit pressure (real-time)		X	X
ppCO ₂ (real-time).		X	X
Consumables (power, oxygen, water, etc., real-time)	X	X	X
Thermal loading to each EVA crewmember (calculated)			X
Heart rate (real-time)		X	X
Metabolic Rate (calculated)			X
Radiation Exposure Data			X
Notes:			
<ul style="list-style-type: none"> For suited operations, measure the parameters in gray on an individual suit basis as specified in HS11015 and telemeter individually. For a single gas environment, ppO₂ and total suit pressure are identical values and do not require separate sensors. Otherwise for a mixed gas environment, measure these two parameters individually as specified in HS11015. 			

Rationale: Ground medical support and crewmembers will need to see biomedical telemetry during contingency and mission-preserving EVA, as well as during unrecoverable vehicle pressure loss, to ensure the health and safety of the crewmembers and to provide appropriate information to the Flight Director. Supervision of the biomedical data and relevant suit atmospheric conditions will maximize crew resource management for the event and minimize the risk for the crewmembers. These data will also be monitored during nominal lunar surface operations to ensure the health and safety of the crew, although automated suit algorithms may be the primary method rather than ground medical support. Although core temperature monitoring is not a requirement for suited operations, the suits shall provide other markers (liquid cooling garment inlet/outlet

Revision: E	Document No: CxP 70024
Release Date: 11/19/10	Page: 180 of 503
Title: Constellation Program Human-Systems Integration Requirements	

temperatures, heart rate, O₂ consumption, and CO₂ concentration) of thermal status. Pressurized operations includes any microgravity EVA, DCS treatment, and unpressurized cabin IVA events. This requirement will be met by integrated systems with the details of each system's responsibility defined in individual system SRDs and in IRDs.

4 HUMAN-SYSTEMS VERIFICATION REQUIREMENTS

4.1 ANTHROPOMETRY, BIOMECHANICS, AND STRENGTH

4.1.1 Anthropometry

4.1.1.1 Anthropometric Dimensions for Unsuiting Crewmembers

[HS2001V] The fit, access, reach, view, and operation shall be verified by analysis and test. The analysis shall include review of designs, drawings, flight-like mockups, and flight-like prototypes and extraction of measurements to compare against the information contained in Appendix B, tables Anthropometric Dimensional Data for American Female and Male, Vehicle Design Critical Anthropometry Dimensions, and Suit Design Critical Anthropometry Dimensions. The analysis shall consist of task and worksite analysis performed on all crew functional areas. The test shall measure the crew while physically interacting with a crew functional area within a flight or flight equivalent mockup. The analysis and test results shall be verified against Appendix B, tables Anthropometric Dimensional Data for American Female and Male, Vehicle Design Critical Anthropometry Dimensions, and Suit Design Critical Anthropometry Dimensions by means of population analytical methods. The verification shall be considered successful when the analysis and test show that the measurements have been met and that the entire range of unsuited crew can fit, access, reach, view, and operate all the human-systems interfaces.

Rationale: It is necessary to ensure that all human-systems interfaces do accommodate the entire current and future crew whose body dimensions have a specified range. Inspection provides the opportunity to inspect and measure hardware dimensions that can be compared against the anthropometric dimensional ranges. Task and worksite analyses provide the opportunity to test the interfaces with a limited number of human test subjects. Hence, they will only provide the partial results on the test subjects. Therefore, a population analysis is a necessary analytical method to ensure that all current and future crewmembers are able to interface with the system hardware.

4.1.1.2 Anthropometric Dimensions for Suited Crewmembers

[HS2002V] The fit, access, reach, view, and operation shall be verified by analysis and test. The analysis shall include review of designs, drawings, flight-like mockups, and flight-like prototypes and extraction of measurements to compare against the information contained in Appendix B, table Vehicle Design Critical Anthropometry Dimensions and table Suit Design Critical Anthropometry Dimensions. The analysis shall consist of task and worksite analysis performed on all crew functional areas. The

Revision: E	Document No: CxP 70024
Release Date: 11/19/10	Page: 181 of 503
Title: Constellation Program Human-Systems Integration Requirements	

test shall measure the crew while physically interacting with a crew functional area within a flight or flight equivalent mockup. The analysis and test results shall be verified against Appendix B, table Vehicle Design Critical Anthropometry Dimensions and table Suit Design Critical Anthropometry Dimensions by means of population analytical methods. The verification shall be considered successful when the analysis and test show that the measurements have been met, and that the entire range of suited crew can fit, access, reach, view, and operate all the human-systems interfaces.

Rationale: It is necessary to ensure that all human-systems interfaces do accommodate the entire current and future crew whose body dimensions have a specified range. Inspection provides the opportunity to inspect and measure hardware dimensions that can be compared against the anthropometric dimensional ranges. Task and worksite analyses provide the opportunity to test the interfaces with a limited number of suited human test subjects. Hence, they will only provide the partial results on the test subjects. Therefore, a population analysis is a necessary analytical method to ensure that all current and future crewmembers are able to interface with the system hardware.

4.1.2 Range of Motion

4.1.2.1 Range of Motion of an Unsited Crewmember

[HS2003V] The unsited crewmember range of motion shall be verified by analysis and test. The analysis shall include the review of designs, drawings, flight-like mockups, and flight-like prototypes and extraction of measurements to compare against the information in Appendix B, table Unsited Joint Mobility. The analysis shall consist of task and worksite analyses performed on all crew functional areas. The test shall measure the crew while physically interacting with a crew functional area within a flight or flight equivalent mockup. The analysis and test results shall be verified against Appendix B, table Unsited Joint Mobility by means of population analytical methods. The verification shall be considered successful when the analysis and test show that the measurements have been met and that the unsited crew can physically interact within the crewmember ranges of motion.

Rationale: It is necessary to ensure that all human-systems interfaces accommodate the entire current and future crew whose ranges of motion have a specified range. Inspection provides the opportunity to inspect and measure hardware dimensions that can be compared against the range of motion ranges. Task and worksite analyses provide the opportunity to test the interfaces with a limited number of human test subjects. Hence, they will only provide the partial results on the test subjects. Therefore, a population analysis is a necessary analytical method to ensure that all current and future unsited crewmembers are able to interface with the system hardware.

Revision: E	Document No: CxP 70024
Release Date: 11/19/10	Page: 182 of 503
Title: Constellation Program Human-Systems Integration Requirements	

4.1.2.2 Range of Motion of a Suited Crewmember

[HS2004V] The suited crewmember range of motion shall be verified by analysis and test. The analysis shall include the review of designs, drawings, flight-like mockups, and flight-like prototypes and extraction of measurements to compare against the information in Appendix B, table Unpressurized Suited Joint Mobility and table Pressurized Suited Joint Mobility for Nominal Pressure Microgravity Operations. The analysis shall consist of task and worksite analyses performed on all crew functional areas. The test shall measure the crew while physically interacting with a crew functional area within a flight or flight equivalent mockup. The analysis and test results shall be verified against Appendix B, table Unpressurized Suited Joint Mobility and table Pressurized Suited Joint Mobility for Nominal Pressure Microgravity Operations by means of population analytical methods. The verification shall be considered successful when the analysis and test show that the measurements have been met and that the suited crew can physically interact within the crewmember ranges of motion.

Rationale: It is necessary to ensure that all human-systems interfaces accommodate the entire current and future suited crew whose ranges of motion have a specified range. The test provides the opportunity to measure the crew while physically interacting with the hardware and can be compared against the range of motion ranges. Task and worksite analyses provide the opportunity to test the interfaces with a limited number of human test subjects. Hence, they will only provide the partial results on the test subjects. Therefore, a population analysis is a necessary analytical method to ensure that all current and future suited crewmembers are able to interface with the system hardware.

4.1.3 Mass Properties

4.1.3.1 Total Crew Control Mass

[HS2010V] The capability to deliver total crew mass to destination and return to earth shall be verified by analysis. The analysis shall consider vehicle, cargo, and crew mass; flight performance; and center of gravity of the crewed launch vehicles and spacecraft. The verification shall be considered successful when the analysis shows that the crew mass delivered capability of the system is equal to or greater than the value in HS2010, table Total Crew Control Mass.

Rationale: No further rationale is required.

4.1.3.2 Mass Properties of an Unsuited Crewmember

[HS2005V] Not Applicable.

4.1.3.3 Mass Properties of a Suited Crewmember

[HS2006V] Sustaining the maximum mass of a suited subject for human system interfaces shall be verified by analysis. The analysis shall include the review of designs, drawings, flight-like mockups, and flight-like prototypes and strength computations to compare against the information in Appendix B, table Whole-Body Mass of

Revision: E	Document No: CxP 70024
Release Date: 11/19/10	Page: 183 of 503
Title: Constellation Program Human-Systems Integration Requirements	

Crewmember. The analysis shall be performed to determine if damage will occur on those human-systems interfaces that are normally subjected to high forces during normal operation and emergency operations. The verification shall be considered successful when the analysis shows that the vehicle systems with human interfaces accommodate the maximum suited crewmember mass per Appendix B, table Whole-Body Mass of Crewmember.

Rationale: No further rationale is required.

4.1.4 Strength

4.1.4.1 Structural Integrity of Hardware for an Unsited Crewmember

[HS2007V] "Maximum Crew Operational Loads" by unsited crew shall be verified by analysis. The analysis shall include the review of designs, drawings, flight-like mockups, and flight-like prototypes and extraction of measurements to compare against the information in Appendix B, table Unsited Strength Data. The structural analysis shall be performed to determine if damage will occur on those components that are normally subjected to high forces during normal operation and emergency operations. The analysis results shall be verified against Appendix B, table Unsited Strength Data. The verification shall be considered successful when the analysis shows that the strength measurements have been met and that the unsited crewmember can physically interact within the components/systems.

Rationale: It is necessary to ensure that all human-system interfaces do accommodate the entire current and future crew structural limits. Analysis provides the opportunity to measure hardware dimensions that can be compared against the structural limits. Task and worksite analyses provide the opportunity to verify human interfaces. A population analysis is a necessary analytical method to ensure that all current and future crewmembers are able to interface with the system hardware.

Revision: E	Document No: CxP 70024
Release Date: 11/19/10	Page: 184 of 503
Title: Constellation Program Human-Systems Integration Requirements	

4.1.4.2 Structural Integrity of Hardware for a Suited Crewmember

[HS2007BV] Not Applicable.

4.1.4.3 Minimum Crew Operational Loads for an Unsuited Crewmember

[HS2008V] "Minimum Crew Operational Loads" for unsuited crew shall be verified by analysis and test. The analysis shall include the review of designs, drawings, flight-like mockups, and flight-like prototypes and extraction of measurements to compare against the information in Appendix B, table Unsuited Strength Data. The analysis shall be performed to determine if crewmembers can operate all components. The test shall consist of a set of tasks to test the minimum operational loads required by the components. The analysis and test results shall be verified against Appendix B, table Unsuited Strength Data by means of population analytical methods. The verification shall be considered successful when the analysis and test show that the strength measurements have been met and that the crewmember can physically interact and operate all components.

Rationale: It is necessary to ensure that all human-systems interfaces do accommodate the entire current and future Minimum Crew Operational Load limits. Analysis and testing provide the opportunity to determine that hardware is within the Minimum Crew Operational Loads limits. Therefore, analysis and testing is necessary to ensure that all current and future crewmembers are able to interface and operate with the system hardware.

4.1.4.4 Minimum Crew Operational Loads for a Suited Crewmember

[HS2008BV] Not Applicable.

4.1.4.5 Equipment Damage Hazard

[HS2009V] The systems' withstanding of crew-induced loads will be verified by analysis. The analysis shall show that the system components have the ability to withstand crew induced loads as documented per CxP 70136-ANX01, Constellation Program Loads Data Book, Annex 1: System-to-System Interface Loads, Section 3.0 and CxP 70135, Constellation Program Structural Design and Verification Requirements, Section 3.0. The verification shall be considered successful when the analysis shows positive margins of safety for the system components.

Rationale: No further rationale is required.

Revision: E	Document No: CxP 70024
Release Date: 11/19/10	Page: 185 of 503
Title: Constellation Program Human-Systems Integration Requirements	

4.2 NATURAL AND INDUCED ENVIRONMENTS

4.2.1 Atmosphere

4.2.1.1 Atmospheric Quality for Nominal Vehicle Operations

4.2.1.1.1 Total Pressure for Nominal Vehicle Operations

[HS3004V] Maintaining total internal pressure within the specified range shall be verified by analysis supported by test. The analysis shall include a review of the vehicle design and the measurements of total internal pressure during operation of an integrated vehicle system. At the vehicle or subsystem level, a test shall be performed using the vehicle's pressure control system in a controlled volume (i.e., pressure or vacuum chamber) with actual or simulated metabolic loads over the maximum mission duration to verify total internal pressure control. The verification shall be considered successful when the test and analysis data show that the vehicle can maintain total pressure of the internal atmosphere within 51.7 kPa (7.50 psia) (388 mmHg) and 103 Pa (15.0 psia) (773 mmHg).

Rationale: No further rationale is required.

4.2.1.1.2 O₂ Partial Pressure for Nominal Vehicle Operations

[HS3004BV] The maintenance of oxygen partial pressure shall be verified by analysis supported by test. The analysis shall include a review of the vehicle design and the measurements of partial pressure oxygen during operation of an integrated vehicle system. At the vehicle or subsystem level, a test shall be performed using the vehicle's pressure control system in a controlled volume (i.e., pressure or vacuum chamber) with actual or simulated metabolic loads over the maximum mission duration to verify oxygen partial pressure control. The verification shall be considered successful when the test and analysis data show that the vehicle can maintain the partial pressure oxygen of the internal atmosphere within the ranges described in the requirement.

Rationale: No further rationale is required.

4.2.1.1.3 CO₂ Partial Pressure for Nominal Vehicle Operations

[HS3004CV] The maintenance of carbon dioxide partial pressure shall be verified by analysis supported by test. The analysis shall include a review of the vehicle design and the measurements of partial pressure carbon dioxide during operation of an integrated vehicle system. At the vehicle or subsystem level, a test shall be performed using the vehicle's pressure control system and the contaminant control system in a controlled volume (i.e., pressure or vacuum chamber) with actual or simulated metabolic loads over the maximum mission duration to verify carbon dioxide partial pressure control. The verification shall be considered successful when the test and analysis data show that the vehicle can maintain the partial pressure of carbon dioxide in the internal atmosphere to less than 0.67 kPa (0.10 psi) (5.0 mmHg) average over any 1-hour timeframe.

Revision: E	Document No: CxP 70024
Release Date: 11/19/10	Page: 186 of 503
Title: Constellation Program Human-Systems Integration Requirements	

Rationale: No further rationale is required.

4.2.1.1.4 N₂ Partial Pressure for Nominal Vehicle Operations

[HS3004DV] The maintenance of partial pressure nitrogen shall be verified by analysis and test. The analysis shall include a review of the vehicle design and the measurements of partial pressure nitrogen during operation of an integrated vehicle system test. The verification shall be considered successful when the analysis shows that the vehicle can maintain the partial pressure nitrogen of the internal atmosphere within the ranges described in the requirement.

Rationale: No further rationale is required.

4.2.1.2 Atmospheric Quality Limits for Crew Exposure

4.2.1.2.1 Total Pressure Tolerance Ranges for Crew Exposure

[HS3005V] The maintenance of atmospheric pressure shall be verified by analysis supported by test. The analysis shall include a review of the vehicle design and the measurements of atmospheric pressure during operation of an integrated vehicle system under nominal conditions. At the vehicle or subsystem level, a test shall be performed using the vehicle's pressure control system in a controlled volume (i.e., pressure or vacuum chamber) with actual or simulated metabolic loads over the maximum mission duration to verify atmospheric pressure control. The verification shall be considered successful when the test and analysis data show that the vehicle can maintain pressure of the internal atmosphere within the limits specified in HS3005, table Physiological Total Pressure Limits for Crew Exposure.

Rationale: No further rationale is required.

4.2.1.2.2 O₂ Partial Pressure Tolerance Ranges for Crew Exposure

[HS3005BV] Maintaining the operating limits of the oxygen partial pressure shall be verified by analysis supported by test. The analysis shall include a review of the vehicle design and the measurements of partial pressure oxygen during operation of an integrated vehicle system. At the vehicle or subsystem level, a test shall be performed using the pressure control system of the vehicle in a controlled volume (i.e., pressure or vacuum chamber) with actual or simulated metabolic loads over the maximum mission duration to verify oxygen partial pressure control. The verification shall be considered successful when the test and analysis data show that the vehicle can maintain the partial pressure of oxygen in the internal atmosphere within the limits specified in HS300B, table Partial Pressure Oxygen Physiological Limits for Crew Exposure.

Rationale: No further rationale is required.

4.2.1.2.3 CO₂ Partial Pressure Tolerance Ranges for Crew Exposure

[HS3005CV] The maintenance of carbon dioxide partial pressure shall be verified by analysis supported by test. The analysis shall include a review of the vehicle design

Revision: E	Document No: CxP 70024
Release Date: 11/19/10	Page: 187 of 503
Title: Constellation Program Human-Systems Integration Requirements	

and the measurements of partial pressure carbon dioxide during operation of an integrated vehicle system. At the vehicle or subsystem level, a test shall be performed using the vehicle's pressure control system in a controlled volume (i.e., pressure or vacuum chamber) with actual or simulated metabolic loads over the maximum mission duration to verify carbon dioxide partial pressure control. The verification shall be considered successful when the test and analysis data show that the vehicle can maintain the partial pressure of carbon dioxide in the internal atmosphere within the limits specified in HS3005C, table Partial Pressure CO₂ Physiological Limits for Crew Exposure.

Rationale: No further rationale is required.

4.2.1.3 Control, Display and Alerting of Atmospheric Parameters

4.2.1.3.1 O₂ and Total Pressure Control

[HS3001V] Adjusting total pressure and ppO₂ shall be verified by test. The test shall include adjusting and measuring the ppO₂ and total pressure during operation of an integrated vehicle system. The verification shall be considered successful when the test shows that the ppO₂ and total pressure can be adjusted by the crew and Constellation Systems within the ranges defined in requirements HS3004 and HS3004B.

Rationale: No further rationale is required.

4.2.1.3.2 Composition Reporting

[HS3013V] Displaying total pressure, partial pressure oxygen, and partial pressure carbon dioxide measurements to the crew shall be verified by demonstration. The demonstration shall be an observation of the displays during various atmospheric conditions. The verification shall be considered successful when the demonstration shows that total pressure, the partial pressure of oxygen, and the partial pressure of carbon dioxide can be displayed to the crew.

Rationale: No further rationale is required.

4.2.1.3.3 Composition Alerting

[HS3014V] Alerting the crew when the total pressure, ppO₂, ppCO₂, or ppN₂ exceeds acceptability limits shall be verified by analysis supported by test. The test shall exercise the caution and warning system by entering values that exceed the cabin atmospheric condition limits for total pressure, ppO₂, ppCO₂, or ppN₂. The verification shall be considered successful when the analysis and test data show that the systems can successfully detect and alert the crew when the constituents exceed limits described in HS3004, HS3004B, HS3004C, HS3004D, HS3005, HS3005B, and HS3005C.

Rationale: No further rationale is required.

Revision: E	Document No: CxP 70024
Release Date: 11/19/10	Page: 188 of 503
Title: Constellation Program Human-Systems Integration Requirements	

4.2.1.4 Contaminants

4.2.1.4.1 Microbial Air Contamination

[HS3006V] The limitation of microbial contaminants in the internal atmosphere shall be verified by analysis. The analysis shall include a review of the vehicle design. The verification shall be considered successful when the analysis shows that the average continuous air flow within the vehicle can remain at or above 20 cubic feet per minute (CFM) per person of air which has been cleaned to have at least 99.97% of airborne particles 0.3 micrometers (μm) and larger in diameter/size removed.

Rationale: No further rationale is required.

4.2.1.4.2 Particulate Contamination

[HS3006CV] The limit of particulate in the internal atmosphere shall be verified by analysis. The analysis shall include a review of the vehicle design. The verification shall be considered successful when the analysis shows that the 24-hour average particulate concentration within the vehicle remains below 0.2 mg/m^3 for particles ranging from 0.5 micron to 100 microns in aerodynamic diameter and generated at a rate of 0.09 mg/person-minute.

Rationale: No further rationale is required.

4.2.1.4.3 Lunar Dust Contamination

[HS3006DV] The limit of lunar dust in the internal atmosphere shall be verified by analysis. The analysis shall include a review of the vehicle design and testing of the Atmosphere Revitalization System (ARS). The verification shall be considered successful when the analysis and tests show that the particulate contamination of less than 10 microns and equal to or greater than 0.1 micron size <TBR-70024-004> within the vehicle can remain below 0.05 mg/m^3 .

Rationale: No further rationale is required.

4.2.1.5 Gaseous Pollutants Limits

4.2.1.5.1 Gaseous Pollutants Limits

[HS3007V] Control of gaseous pollutants in the habitable volume shall be verified by analysis supported by subsystem test. The analysis shall be based on the review of vehicle design and on measurements of trace chemical contaminant concentration buildup as a function of time acquired during an integrated vehicle system off-gassing test conducted according to NASA-STD-6001, Flammability, Odor, Off-Gassing, and Compatibility Requirements and Test Procedures for Materials in Environments that Support Combustion, Test 12. The analysis supported by subsystem test data shall show that the vehicle controls the concentration of individual trace chemical contaminants introduced into the cabin for the load defined by HS3007V, table Trace Chemical Contaminant Design Load to less than 50 percent of the maximum

Revision: E	Document No: CxP 70024
Release Date: 11/19/10	Page: 189 of 503
Title: Constellation Program Human-Systems Integration Requirements	

concentration. HS3007V, table Trace Chemical Contaminant Design Load is a subset of parameters derived from JSC 20584, Spacecraft Maximum Allow Concentrations for Airborne Contaminants and is to be used as the design load until system offgassing test data become available. The verification shall be considered successful when the analysis shows that gaseous pollutants in HS3007V, table Trace Chemical Contaminant Design Load are maintained to less than 50 percent of the maximum values in this table.

Rationale: Extensive study of trace contaminant control equipment performance and cabin air quality data from NASA's crewed space exploration program, including Shuttle, Spacelab, NASA-Mir, and International Space Station, has established that active trace chemical contaminant control is necessary for maintaining cabin air quality that is healthy for human occupants. The design load model basis is NASA/TP-1998-207978, Elements of Spacecraft Cabin Air quality Design and NASA/TM 108497 supplemented by engineering evaluation of in-flight cabin air quality sample analyses from NASA's crewed space exploration program. Multiple precautions must be incorporated into the vehicle design and operation to achieve acceptable air quality. Accomplishing these tasks to meet the requirement can only be verified using in-flight samples obtained during missions.

TABLE 4.2.1.5.1-1 - TRACE CHEMICAL CONTAMINANT DESIGN LOAD

CONTAMINANT	MAXIMUM CONCENTRATION (mg/m ³) ^a	GENERATION RATE		
		OFFGASSING (mg/d-kg) ^b	METABOLIC (mg/d-person)	SYSTEM (mg/d)
Methanol	90	1.3×10^{-3}	0.9	0
Ethanol	2,000	7.8×10^{-3}	4.3	1,000
n-butanol	40	4.7×10^{-3}	0.5	0
Methanal (formaldehyde)	0.12	4.4×10^{-6}	0.4	0
Ethanal (acetaldehyde)	3.6	1.1×10^{-4}	0.6	0
Benzene	0.2	2.5×10^{-5}	2.2	0
Methylbenzene (toluene)	15	2×10^{-3}	0.6	0

Revision: E	Document No: CxP 70024
Release Date: 11/19/10	Page: 190 of 503
Title: Constellation Program Human-Systems Integration Requirements	

TRACE CHEMICAL CONTAMINANT DESIGN LOAD (CONCLUDED)

CONTAMINANT	MAXIMUM CONCENTRATION (mg/m ³) ^a	GENERATION RATE		
		OFFGASSING (mg/d-kg) ^b	METABOLIC (mg/d-person)	SYSTEM (mg/d)
Dimethylbenzenes (xylenes)	48	3.7×10^{-3}	0.2	0
Furan	0.07	1.8×10^{-6}	0.3	0
Dichloromethane	10	2.2×10^{-3}	0.09	0
2-propanone (acetone)	52	3.6×10^{-3}	19	0
Trimethylsilanol	4	1.7×10^{-4}	0	0
Hexamethylcyclotrisiloxane	9	1.7×10^{-4}	0	0
Ammonia	3.5	8.5×10^{-5}	50	175 ^c
Carbon monoxide	17	2×10^{-3}	18	0
Hydrogen ^d	340	5.9×10^{-6}	42	0
Methane ^d	3,800	6.4×10^{-4}	329	0

a. 180-day Spacecraft Maximum Allowable Concentration from JSC 20584 dated June 1999 except TBR.
b. Offgassing rate is for the mass of internal, non-structural equipment.
c. Ammonia generation by amine-containing system components, zero if no amine present.
d. For mission operations concepts >1 month duration.

4.2.1.6 Rate of Change of Pressure Limits

4.2.1.6.1 Rate of Change of Pressure Limits

[HS3009V] The rate of total pressure change shall be verified by analysis. The analysis shall include a review of the vehicle design and an evaluation of the worst-case scenario for pressure change during nominal operations. The verification shall be considered successful when the analysis indicates that the vehicle will not exceed the pressure change described in the requirement.

Rationale: No further rationale is required.

4.2.1.7 Combustion Products

4.2.1.7.1 Combustion Products Measurement

[HS3012BV] The ability of the system to measure the specified atmospheric gas concentrations in real time in the required ranges shall be verified by test. The test shall show that the atmospheric monitoring instruments correctly determine the atmospheric gas concentrations over the given ranges. The verification shall be considered successful when the test shows a real time capability for the measurement of atmospheric concentrations of the specified toxic combustion products over the specified ranges.

Rationale: The measurement capabilities of the atmospheric monitoring instruments can be verified by tests outside the vehicle. Accuracy of measurement is not specified; therefore, commercial laboratory instrument accuracy can be assumed.

Revision: E	Document No: CxP 70024
Release Date: 11/19/10	Page: 191 of 503
Title: Constellation Program Human-Systems Integration Requirements	

4.2.1.7.2 Combustion Products Monitoring

[HS3012AV] The ability of the vehicle to monitor and display atmospheric concentrations of CO, HCN, and HCl in the habitable volume of the vehicle in real time shall be verified by test and analysis. Tests shall show that the atmospheric monitoring instruments correctly determine the gas concentrations and that these concentrations will be correctly displayed in real time in the vehicle. The analysis shall show that the atmospheric composition, pressure, circulation, and availability to the monitoring instruments provide the correct measurement of the gas concentrations. The verification shall be considered successful when the tests and analysis show that the atmospheric concentrations of CO, HCN, and HCl in the habitable volume of the vehicle combustion products will be monitored and displayed in real time.

Rationale: The measurement capabilities of the atmospheric monitoring instruments can be verified by tests outside the vehicle. The atmospheric concentration displays may be part of stand-alone instruments, so that the displays can also be verified outside the vehicle, or they may be integrated with other vehicle display systems and require a vehicle test. Analysis of atmosphere conditions and circulation and presentation to the instruments is needed to confirm their performance in the vehicle.

4.2.1.7.3 Carbon Monoxide Alert

[HS3012DV] The ability of the system to alert the crew whenever the carbon monoxide (CO) concentration exceeds the lower limit in HS3012B shall be verified by inspection and test. The inspection shall examine verification compliance data for requirement HS3012B to confirm that the instrumentation correctly detects CO concentration at and above the lower detectable limit specified in HS3012B. The test shall show that the detection of CO exceeding the lower limit produces an alarm to alert the crew. The verification shall be considered successful when the inspection and test show that the alert system alerts the crew whenever the CO concentrations exceed the lower limit specified in HS3012B.

Rationale: The CO alarm, which may be part of the CO detection instruments or may be integrated with other vehicle systems, requires an on vehicle test.

4.2.1.8 Hazardous Chemicals

4.2.1.8.1 Toxic Hazard Level 3

[HS3015V] The use of Toxic Hazard Level 3 or lower chemicals in the habitable volume of the system shall be verified by analysis. The analysis shall include a design review of the materials and chemicals selected for vehicle construction and their use in the operation of the vehicle. The verification shall be considered successful when the analysis shows Toxic Hazard Level 3 or lower chemicals are the only chemicals used in the habitable volume of the vehicle.

Revision: E	Document No: CxP 70024
Release Date: 11/19/10	Page: 192 of 503
Title: Constellation Program Human-Systems Integration Requirements	

Rationale: The verification process involves 3 steps: 1) identification of potential compounds that could decompose in environmental systems, 2) identification of the products of decomposition, if any, and 3) determination if any decomposition products would be toxic at the concentrations anticipated.

4.2.1.8.2 Toxic Hazard Level 4

[HS3015AV] The prevention of Toxic Hazard Level 4 chemicals from entering the habitable volume of the system shall be verified by analysis. The analysis shall include a design review of the materials and chemicals selected for system construction and their use in the operation of the vehicle. The analysis shall identify the location of any Toxic Hazard Level 4 chemicals and their levels of containment. The verification shall be considered successful when the analysis shows that Toxic Hazard Level 4 chemicals cannot enter the habitable volume of the vehicle.

Rationale: No further rationale is required.

4.2.1.8.3 Decomposition of Chemicals

[HS9037V] The prevention of chemical decomposition into hazardous compounds in the habitable volume shall be verified by analysis and inspection. The analysis shall identify chemicals that will be exposed to or have the potential to be introduced into the habitable volume and the likely chemical interactions with the environment. The inspection shall include a review of Constellation Safety Review Panel approval documentation. The verification shall be considered successful when the analysis and inspection show that no chemicals have been used in the system's design that can be broken down or converted into compounds that threaten crew health and have the potential to be introduced into the habitable volume.

Rationale: The verification process involves 3 steps: 1) identification of potential compounds that could decompose in environmental systems, 2) identification of the products of decomposition, if any, and 3) determination if any decomposition products would be toxic at the concentrations anticipated.

4.2.1.9 Crew Protection

4.2.1.9.1 Personal Protective Equipment

[HS3016V] The provision of stowage space for PPE shall be verified by inspection. The inspection shall include a review of the system design to ensure accessible stowage space for PPE. The inspection shall identify the presence of PPE. The verification shall be considered successful when the inspection identifies adequate stowage space and the presence of PPE.

Rationale: No further rationale is required.

Revision: E	Document No: CxP 70024
Release Date: 11/19/10	Page: 193 of 503
Title: Constellation Program Human-Systems Integration Requirements	

4.2.1.9.2 Contingency Breathing Apparatus

[HS3017AV] The provisioning of a contingency breathing apparatus for each member of the crew with air that meets the quality specification defined in HS3004B, HS3004C, and HS3004D shall be verified by analysis and inspection. The analysis shall determine the amount of breathing gas required for contingency provision to the entire crew. The inspection shall identify the amount of breathing gas provided in the system for contingency use. The verification shall be considered successful when the analysis and inspection show that each crewmember has a contingency breathing apparatus with air that meets the quality specification defined in HS3004B, HS3004C, and HS3004D.

Rationale: No further rationale is required.

4.2.1.9.3 Crew Communication During Contingency Breathing

[HS3017V] The presence of communication capability shall be verified by demonstration. The demonstration shall include communication between individuals using the contingency breathing apparatus and flight or flight-like hardware. The verification shall be considered successful when the demonstration shows communication between crewmembers while wearing the contingency breathing apparatus.

Rationale: No further rationale is required.

4.2.1.9.4 Mission Systems Communication During Contingency Breathing

[HS3017BV] The presence of communication capability shall be verified by demonstration. The demonstration shall include communication between vehicle and ground individuals using the flight or flight-like contingency breathing apparatus connected to a flight or flight-like communication system. The verification shall be considered successful when the demonstration shows communication between the contingency breathing apparatus and Mission Systems.

Rationale: No further rationale is required.

4.2.2 Potable Water

4.2.2.1 Potable Water Quality

4.2.2.1.1 Physiochemical Limits for Potable Water

[HS3019V] Physiochemical water quality shall be verified by test. The test shall include evaluation of a fully integrated flight-equivalent water system for a length of time equal to the longest period expected between preparation of potable water and crew recovery. Samples shall be collected from multiple ports throughout the water system to verify compliance. These tests shall be conducted using standard laboratory techniques described in Standard Methods for Examination of Water & Wastewater, American Public Health Association or alternate approved methodology that will provide

Revision: E	Document No: CxP 70024
Release Date: 11/19/10	Page: 194 of 503
Title: Constellation Program Human-Systems Integration Requirements	

comparable data. The verification shall be considered successful when test data are compliant with HS3019, table Potable Water Physiochemical Limits.

Rationale: Comprehensive in-flight analysis is impractical. Verification will be completed by ground longevity testing of the full-scale water system. Previous experience has shown that engineering design analysis cannot account for all factors affecting water quality, and full-scale tests are necessary to ensure water quality. Water quality is affected by long-term contact with materials of construction and other design aspects that would only be revealed in a high-fidelity integrated ground test. Analytical methods that are not listed in Standard Methods for Examination of Water and Wastewater must be approved by the JSC water quality group prior to use.

4.2.2.1.2 Microbial Limits for Potable Water

[HS3019AV] Microbiological water quality shall be verified by test. The test shall include evaluation of a fully integrated flight-equivalent water system for a length of time equal to the longest period expected between preparation of potable water and crew recovery. Samples shall be collected from all locations throughout the water system to which the crew may be exposed to verify compliance. These tests shall be conducted using standard laboratory techniques described in Standard Methods for Examination of Water & Wastewater, American Public Health Association or alternate approved methodology that will provide comparable data. The verification shall be considered successful when test data are compliant with HS3019A, table Potable Water Microbial Limits.

Rationale: Comprehensive in-flight analysis is impractical. Verification will be completed by ground longevity testing of the full-scale water system. Previous experience has shown that engineering design analysis cannot account for all factors affecting water quality, and full-scale tests are necessary to ensure water quality. Water quality is affected by the growth of microorganisms during water storage and by other design aspects that would only be revealed in a high-fidelity integrated ground test. Analytical methods that are not listed in Standard Methods for Examination of Water & Wastewater must be approved by the JSC microbiology group prior to use.

4.2.2.2 Potable Water Quantity

4.2.2.2.1 Potable Water for On-Orbit Drinking

[HS3025V] The provisioning of the specified quantity of potable water shall be verified by analysis. The analysis shall determine the amount of potable water stowage on the vehicle for all vehicle configurations. The verification shall be considered successful when the analysis shows sufficient volume and mass capacity for stowage of potable water in the amount of 2.0 L (67.6 fl oz) of potable water per crewmember per mission day (in addition to other potable water requirements), utilizing maximum crew size and maximum mission duration.

Revision: E	Document No: CxP 70024
Release Date: 11/19/10	Page: 195 of 503
Title: Constellation Program Human-Systems Integration Requirements	

Rationale: No further rationale is required.

4.2.2.2.2 Potable Water for On-Orbit Food Rehydration

[HS3127V] The provisioning of the specified quantity of potable water shall be verified by analysis. The analysis shall determine the amount of potable water stowage on the vehicle for all vehicle configurations. The verification shall be considered successful when the analysis shows sufficient volume and mass capacity for stowage of potable water in the amount of 500 mL (16.9 fl oz) of potable water per crewmember per mission day (in addition to other potable water requirements), utilizing maximum crew size and maximum mission duration.

Rationale: No further rationale is required.

4.2.2.2.3 Potable Hot Water Quantity for Rehydration

[HS3118V] The system's provision of 600 mL (20.3 fl oz) of hot water per person per meal for four crewmembers at the temperature required in HS3031 shall be verified by inspection and test. The inspection shall ensure that the system can provide hot water per requirement HS3031. The test shall measure that the system can provide 600 mL (20.3 fl oz) of hot water per crewmember per meal for four crewmembers. Verification shall be considered successful when inspection has verified that the system can provide hot water per requirement HS3031 and test has verified that the system can provide 600 mL (20.3 fl oz) of hot water per crewmember per meal for four crewmembers.

Rationale: No further rationale is required.

4.2.2.2.4 Potable Water for Personal Hygiene

[HS3028V] The capability of the system to provide 400 mL (13.5 fl oz) of potable water per crewmember-day shall be verified by analysis. The analysis includes a design review of the system to show that this quantity of water is available for personal hygiene. (The water in pre-wetted towels counts towards this quantity.) The verification shall be considered successful when the analysis shows sufficient volume and mass capacity to supply this volume of potable water utilizing maximum crew size and maximum mission duration.

Rationale: No further rationale is required.

4.2.2.2.5 Potable Water for Medical Use

[HS3122V] Potable water for medical use events shall be verified by analysis. The analysis shall determine the amount of potable water available on the vehicle for all vehicle configurations. The verification shall be considered successful when the analysis shows that the system can provide potable water in the amount of 500 mL (16.9 fl oz) for medical use per crewmember for nominal eye irrigation particulate events, in addition to other potable water requirements, utilizing maximum crew size and maximum mission duration.

Revision: E	Document No: CxP 70024
Release Date: 11/19/10	Page: 196 of 503
Title: Constellation Program Human-Systems Integration Requirements	

Rationale: No further rationale is required.

4.2.2.2.6 Potable Water for Medical Contingency

[HS3123V] Potable water for medical contingency events shall be verified by analysis. The analysis shall determine the amount of potable water available on the vehicle for all vehicle configurations. The verification shall be considered successful when the analysis shows that the system provides potable water in the amount of 5.0 L (169 fl oz) for contingency events, in addition to other potable water requirements, utilizing maximum crew size and maximum mission duration.

Rationale: No further rationale is required.

4.2.2.2.7 Potable Water for EVA Operations

[HS6063V] The provisioning of water for EVA suited operations shall be verified by analysis. The analysis shall assess the potable water system as a whole. The verification shall be considered successful when the on-board total available potable water quantities provide 240 mL (8.12 fl oz) of potable water per crewmember per EVA hour for the maximum number of mission EVA days, in addition to other potable water requirements.

Rationale: No further rationale is required.

4.2.2.2.8 Potable Water for Fluid Loading

[HS3026V] The provisioning of the specified quantity of potable water for re-entry fluid loading shall be verified by analysis. The analysis shall determine the amount of potable water stowage on the vehicle for all vehicle configurations. The verification shall be considered successful when the analysis shows sufficient volume and mass capacity for stowage of potable water in the amount of 1.0 L (33.8 fl oz) per crewmember (in addition to other potable water requirements) considering maximum crew size for each EOM opportunity.

Rationale: No further rationale is required.

4.2.2.2.9 Potable Water for Post Landing

[HS3027V] The provisioning of the specified quantity of potable water for post-landing recovery shall be verified by analysis. The analysis shall determine the amount of potable water available on the vehicle for all vehicle configurations. The verification shall be considered successful when the analysis shows that the system can provide potable water in the amount of 1.0 L (33.8 fl oz) per 8-hour period of the entire crew recovery period per crewmember, and 500 mL of this total water allotment is readily and immediately accessible by each seated and restrained crewmember during the first 2-hours of post-landing activities (in addition to other potable water requirements), considering maximum crew size.

Rationale: No further rationale is required.

Revision: E	Document No: CxP 70024
Release Date: 11/19/10	Page: 197 of 503
Title: Constellation Program Human-Systems Integration Requirements	

4.2.2.3 Potable Water Delivery

4.2.2.3.1 Potable Water Rate

[HS3029V] The potable water flow rate shall be verified by test. The test shall measure the flow rate of the water in mL/minute. The verification shall be considered successful when the test shows that the flow rate is maintained at a minimum of 500 mL/min (16.9 oz/min).

Rationale: No further rationale is required.

4.2.2.3.2 Potable Water Dispensing

[HS3117V] The capability of the vehicle to dispense water in 15-mL (0.51-fl oz) increments (+/-10% or 5 mL [0.17 fl oz], whichever is greater) between the quantities of 30 mL (1.01 fl oz) and 240 mL (8.12 fl oz) shall be verified by test. Testing shall include dispensing of water in 15-mL (0.51-fl oz) increments, starting at 30 mL (1.01 fl oz). The verification shall be considered successful when the test shows that the water system can dispense water in 15-mL (0.51-fl oz) increments (+/-10% or 5 mL [0.17 fl oz], whichever is greater) between the quantities of 30 mL (1.01 fl oz) and 240 mL (8.12 fl oz).

Rationale: No further rationale is required.

4.2.2.4 Potable Water Temperature

4.2.2.4.1 Potable Water Temperature for Cold Drinks

[HS3030V] Not Applicable

4.2.2.4.2 Potable Water Temperature for Hot Food and Drinks

[HS3031V] The capability of the system to provide potable water between 68.3 °C (155 °F) and 79.4 °C (175 °F) shall be verified by test. Testing will include measurements of the temperature and flow rate of the hot potable water. The verification shall be considered successful when the test shows that the system can provide water at the specified temperature and the flow rate provided in HS3029.

Rationale: No further rationale is required.

4.2.2.4.3 Potable Water Temperature for Personal Hygiene

[HS3032V] Not Applicable

4.2.2.4.4 Potable Water Temperature for Medical Contingency

[HS3121V] Providing potable water for medical use at the specified temperatures shall be verified by analysis. The analysis will determine the temperature of the water to be used for medical events. The verification shall be considered successful when the analysis shows that the system can provide water for medical events between 18 °C (64.4 °F) and 28 °C (82.4 °F).

Revision: E	Document No: CxP 70024
Release Date: 11/19/10	Page: 198 of 503
Title: Constellation Program Human-Systems Integration Requirements	

Rationale: No further rationale is required.

4.2.2.5 Water Sampling

4.2.2.5.1 Water Sampling

[HS3034V] Access to the vehicle potable water systems for sample collection shall be verified by inspection. The inspection will include a review of vehicle and potable water system designs to ensure access to the water supply during ground processing, in-flight, and post-landing. The verification shall be considered successful when the inspection shows access for potable water sample collection during ground processing, in-flight, and post-landing.

Rationale: Numerous factors can quickly affect water quality, as has been demonstrated in previous flight programs. Thus, access to the water supply as close to launch as practical will allow sampling to confirm this quality. As in-flight analysis is impractical, access for post-flight analysis is required to confirm water quality throughout the flight.

4.2.3 Thermal Environment

4.2.3.1 Atmospheric Temperature and Heat Stored by Crewmembers

4.2.3.1.1 Nominal Atmospheric Temperature

[HS3036V] Maintaining the atmospheric temperature within the specified range shall be verified by analysis. The analysis shall include a review of the system design, as well as a thermal model of the habitable volume based on the final flight configuration. The model shall be validated using test data collected from the vehicle during pre-delivery acceptance testing. The verification shall be considered successful when the analysis shows that the temperature can be maintained between 18 °C (64.4 °F) to 27 °C (80.6 °F) during all nominal flight operations, excluding suited operations, ascent, entry, landing, and post-landing.

Rationale: No further rationale is required.

4.2.3.1.2 Contingency Control of Heat Stored by Crewmembers

[HS3037V] The maintenance of the energy stored by the crew shall be verified by analysis. Analysis shall include a review of the system design and demonstration of the system atmospheric control system in a high-fidelity test. The verification shall be considered successful when the analysis shows that the system can maintain ΔQ stored within -4.1 kJ/kg (-1.8 BTU/lb) and 4.7 kJ/kg (2.0 BTU/lb), during simulated thermal conditions experienced during ascent, entry, descent, landing, post-landing, and off-nominal suited and unsuited flight operations.

Rationale: No further rationale is required.

Revision: E	Document No: CxP 70024
Release Date: 11/19/10	Page: 199 of 503
Title: Constellation Program Human-Systems Integration Requirements	

4.2.3.2 Relative Humidity

4.2.3.2.1 Relative Humidity for Nominal Vehicle

[HS3046V] The capability of the system to maintain the average relative humidity level over each 24-hour period between 25 and 75 percent shall be verified by analysis. The analysis shall be based on performance data collected on the Flight Environmental Control and Life Support System during subsystem or vehicle acceptance/qualification testing. The verification shall be considered successful when the analysis demonstrates that the system can maintain the average relative humidity level over each 24-hour period between 25 and 75 percent for all simulated vehicle configurations, excluding suited operations less than 4 hours and post-landing.

Rationale: No further rationale is required.

4.2.3.2.2 Relative Humidity Tolerance Ranges for Crew Exposure

[HS3126V] The capability of the system to restrict human exposure to off-nominal relative humidity levels according to HS3126, table Relative Humidity Tolerance Ranges shall be verified by analysis. The analysis shall be based on performance data collected on the Flight Environmental Control and Life Support System during subsystem or vehicle acceptance/qualification testing. The verification shall be considered successful when the analysis demonstrates that the system can maintain the average relative humidity levels in the simulated vehicle configurations of suited operations less than 4 hours and post-landing.

Rationale: No further rationale is required.

4.2.3.3 Ventilation

4.2.3.3.1 In-flight Ventilation

[HS3047V] The capability to maintain a ventilation rate within the system shall be verified by analysis and test. The analysis shall include a fluid dynamics model of the interior habitable volume and shall be of sufficient fidelity to identify potential areas within the habitable volume with no air movement. The analysis shall include a plan to validate the model using data collected during the vehicles acceptance/qualification testing. The analysis shall consider the ventilation rate only at a single, nominal setting for all fan speeds and diffusers. The test shall be of the flight hardware's response to commands in the flight vehicle. The verification shall be considered successful when the analysis and test establish that two-thirds (66.7%) of the atmosphere velocities are between 4.57 m/min (15 ft/min) and 36.58 m/min (120 ft/min), no more than 5 percent of the velocities are less than 2.13 m/min (7 ft/min), and no more than one percent of the velocities are in excess of 60.96 m/min (200 ft/min at a distance measured more than 0.15 m [6 inches]) from the vehicle walls during all mission phases except during suited operations, toxic cabin events, or when the crew is not inhabiting the vehicle.

Rationale: Values of atmosphere velocities below the lower limit of 2.13 m/min (7 ft/min) are considered too low to prevent hazardous CO₂ and thermal pockets

Revision: E	Document No: CxP 70024
Release Date: 11/19/10	Page: 200 of 503
Title: Constellation Program Human-Systems Integration Requirements	

from forming. Values above the upper limit of 60.96 m/min (200 ft/min) are considered too high, such that they will present acoustic noise and air flow annoyance problems. Atmosphere velocities within 15 cm (6 inches) of the walls are not considered. Finally, fire or toxic release into the habitable volume are examples of periods during which the mentioned ventilation rates are not in the best interest of air quality and crew health. In those cases, the ventilation system may need to be shut down in order to protect the safety of the crew.

4.2.3.3.2 Supplemental Ventilation

[HS3050V] The environment for temporary maintenance activities in areas not in the normal habitable volume shall be verified by test. The test shall be performed in a high-fidelity mockup of the vehicle and shall account for expected crewmember metabolic loads. The verification shall be considered successful when the test shows that the environment is controlled as defined in HS3005B, table Partial Pressure Oxygen Physiological Limits for Crew Exposure; HS3005C, table Partial Pressure CO₂ Physiological Limits for Crew Exposure; and HS3046.

Rationale: No further rationale is required.

4.2.3.4 User Control of Atmospheric Thermal Properties

4.2.3.4.1 Temperature Set-Point Increments

[HS3053V] The increments of set-points for temperature control shall be verified by inspection. The inspection shall include a review of the set-point control. The verification shall be considered successful when the set-point control shows that the temperature can be adjusted in 1 °C (1.8 °F) or less increments within the ranges defined in HS3036.

Rationale: No further rationale is required.

4.2.3.4.2 Temperature Set-Point Adjustment

[HS3051V] The capability of the crew to adjust the atmospheric temperature shall be verified by test. The test shall include the measurements of temperature during operation of an integrated vehicle system. The verification shall be considered successful when the test shows that the temperature can be adjusted by the crew to between 21 °C (69.8 °F) and 27 °C (80.6 °F).

Rationale: No further rationale is required.

4.2.3.4.3 Temperature Set-Point Error

[HS3054V] Temperature control within +/- 1.5 °C (2.7 °F) of the set-point shall be verified by analysis supported by test. The test shall include the measurements of temperature during operation of an integrated vehicle system at various temperatures. The verification shall be considered successful when the analysis of the test results

Revision: E	Document No: CxP 70024
Release Date: 11/19/10	Page: 201 of 503
Title: Constellation Program Human-Systems Integration Requirements	

shows that the temperature can be controlled to +/- 1.5 °C (2.7 °F) of the set temperature within the ranges defined in HS3036.

Rationale: No further rationale is required.

4.2.3.4.4 Temperature Set-Point Accessibility

[HS3052V] The crew adjustment of the atmospheric temperature set-point shall be verified by demonstration. The demonstration shall consist of a single restrained crewmember adjusting the temperature during operation of an integrated vehicle system and shall be demonstrated by a single restrained crewmember. The verification shall be considered successful when the demonstration shows that the temperature can be adjusted by a single crewmember.

Rationale: No further rationale is required.

4.2.3.4.5 Ventilation Adjustment

[HS3114V] The ability for the crew to adjust the ventilation delivery to the cabin shall be verified by inspection. The inspection shall be of the cabin ventilation system. The inspection shall be performed in the flight or flight equivalent vehicle. This Level II requirement may include review of requirement verifications tested at lower levels. The verification shall be considered successful when the inspection shows that the cabin ventilation delivery system is capable of air flow direction adjustment.

Rationale: No further rationale is required.

4.2.3.5 Atmosphere Thermal Properties Monitoring

4.2.3.5.1 Display of Actual Temperature

[HS3115V] Temperature display step sizes shall be verified by inspection. The inspection shall be performed on flight-like hardware. The verification shall be considered successful when the inspection shows actual temperature display step sizes of 1 °C (1.8 °F).

Rationale: No additional rationale is required.

4.2.3.5.2 Display of Temperature Set-Point

[HS3116V] Display step sizes for the temperature set-point shall be verified by inspection. The inspection shall be performed on flight-like hardware. The verification shall be considered successful when the inspection shows that the temperature set-point is displayed in step sizes of 1 °C (1.8 °F).

Rationale: No further rationale is required.

4.2.3.5.3 Display and Monitoring of Temperature and Relative Humidity

[HS3055V] The ability of the system to measure and record temperature and relative humidity shall be verified by demonstration. The demonstration shall be performed in a

Revision: E	Document No: CxP 70024
Release Date: 11/19/10	Page: 202 of 503
Title: Constellation Program Human-Systems Integration Requirements	

flight or flight equivalent vehicle with flight software loads. The demonstration shall be considered successful when it demonstrates the vehicle's ability to correctly measure, display to the crew, and record the temperature within the habitable volume.

Rationale: No further rationale is required.

4.2.4 Acceleration

4.2.4.1 Sustained Linear Acceleration

4.2.4.1.1 Crew Exposure to Rate of Change of Acceleration

[HS3059V] The crew exposure to jerk during sustained events shall be verified by analysis and test. Analysis shall use a certified simulation to verify all nominal flight phase scenarios, as well as 3-sigma bounding Monte Carlo studies with dispersed Guidance, Navigation, and Control (GN&C), vehicle and environmental factors, when appropriate. Tests shall be used to validate the model, using data obtained from nominal flight tests, parachute tests, and/or other available flight and ground-based tests. Test data provide continuous acceleration measures to compute the linear jerk that would be experienced by the crew. Such testing will require on-board acquisition (or sampling) of three-dimensional (3D) linear acceleration (along the x, y, and z axes) on a millisecond timescale. The verification shall be considered successful when the analyses indicate with 99% confidence that the simulated jerk is no greater than 500 g/s during any non impact phase of flight.

Rationale: No further rationale is required.

4.2.4.1.2 Linear Acceleration Limits During Nominal Return

[HS3060V] The crew exposure to sustained linear acceleration during a nominal return to earth shall be verified by analysis and test. Analysis shall use a certified simulation to verify all nominal flight phase scenarios, as well as 3-sigma bounding Monte Carlo studies with dispersed GN&C, vehicle and environmental factors, when appropriate. Tests shall be used to validate the model using data obtained from nominal flight tests, parachute tests, and/or other available flight and ground-based tests. The test data will provide continuous acceleration measures in order to compute the total linear acceleration that would be experienced by the crew directly by translation and indirectly by off-axis rotation (i.e., centrifugal force). Such testing will require on-board acquisition (or sampling) of 3D linear and 3D rotational acceleration (along and around the x, y, and z axes) on a millisecond timescale. The verification shall be considered successful when the analyses indicate with 99% confidence that simulated linear acceleration exposures of 500 ms or more during a nominal return are no greater than the limits depicted by the dotted green lines in the HS3060 figures contained within the section Linear Acceleration Limits During Nominal Return.

Rationale: No further rationale is required.

Revision: E	Document No: CxP 70024
Release Date: 11/19/10	Page: 203 of 503
Title: Constellation Program Human-Systems Integration Requirements	

4.2.4.1.3 Linear Acceleration Limits from Launch to Mission Destination

[HS3061V] The crew exposure to sustained linear acceleration during a nominal trip to destination shall be verified by analysis and test. Analysis shall use a certified simulation to verify all nominal flight phase scenarios, as well as 3-sigma bounding Monte Carlo studies with dispersed GN&C, vehicle and environmental factors, when appropriate. Tests shall be used to validate the model, using data obtained from nominal flight tests, parachute tests, and/or other available flight and ground-based tests. The test data will provide continuous acceleration measures in order to compute the total linear acceleration that would be experienced by the crew directly by translation and indirectly by off-axis rotation (i.e., centrifugal force). Such testing will require on-board acquisition (or sampling) of 3D linear and 3D rotational acceleration (along and around the x, y, and z axes) on a millisecond timescale. The verification shall be considered successful when the analyses indicate with 99% confidence that simulated linear acceleration exposures of 500 ms or more during a nominal around trip are no greater than the limits depicted by the dashed blue lines in the HS3060 figures contained within the section Linear Acceleration Limits During Nominal Return.

Rationale: No further rationale is required.

4.2.4.1.4 Linear Acceleration Limits for Ascent Abort and Off-Nominal Entry

[HS3062V] The crew exposure to sustained linear acceleration during ascent abort and off-nominal entry shall be verified by analysis supported by test. Analysis shall use a certified simulation to verify nominal ascent-abort and off-nominal entry scenarios, as well as 3-sigma bounding Monte Carlo studies with dispersed GN&C, vehicle and environmental factors, when appropriate. Tests shall be used to validate the model, using data obtained from nominal flight tests, parachute tests, and/or other available flight and ground-based tests. The test data will provide continuous acceleration measures in order to compute the total linear acceleration that would be experienced by the crew directly by translation and indirectly by off-axis rotation (i.e., centrifugal force). Such testing will require on-board acquisition (or sampling) of 3D linear and 3D rotational acceleration (along and around the x, y, and z axes) on a millisecond timescale. The verification shall be considered successful when the analyses indicate with 99% confidence that simulated linear acceleration exposures of 500 ms or more during ascent abort and off-nominal entry are no greater than the limits depicted by the solid red lines in the HS3060 figures contained within the section Linear Acceleration Limits During Nominal Return.

Rationale: No further rationale is required.

4.2.4.2 Occupant Protection

4.2.4.2.1 Crew Injury Risks Limits

[HS3064V] The crew exposure to impact acceleration shall be verified by analysis supported by test. Analysis shall verify that the beta index for all Brinkley criteria is equal to or less than 1.0 given the dynamic response limits for the appropriate dynamic

Revision: E	Document No: CxP 70024
Release Date: 11/19/10	Page: 204 of 503
Title: Constellation Program Human-Systems Integration Requirements	

response level in Appendix N, table Dynamic Response Limits. Analysis shall use the Brinkley Model defined in Appendix N, section N2.0 for all necessary flight phases. Tests shall be used to validate the transient accelerations measured at the seat in the analysis models using data obtained from all applicable flight and ground-based tests. The test data shall provide continuous acceleration measures in order to compute the total linear acceleration that would be experienced by the crew directly by translation and indirectly by off-axis rotation (i.e., centrifugal force). Such testing will require onboard acquisition (or sampling) of 3D linear and 3D rotational acceleration (along and around the x, y, and z axes) on a millisecond timescale. The verification shall be considered successful when the analyses indicate with 99% confidence that the beta index for all Brinkley criteria is 1.0 or less during each simulated impact.

Rationale: No further rationale is required.

4.2.4.2.2 Head Protection Criteria

[HS3124V] Not Applicable.

4.2.4.2.3 Head Transient Acceleration Limits

[HS3132V] Not Applicable.

4.2.4.2.4 Neck Protection Criteria

[HS3125V] Not Applicable.

4.2.4.2.5 Transient Force Application Limits

[HS3128V] Not Applicable

4.2.4.2.6 Chest Deflection

[HS3129V] Not Applicable.

4.2.4.2.7 Restrained Body Movement

[HS3130V] Limited crew body movement relative to the seat shall be verified by analysis and test. The analysis shall define the worst-case loads imparted to the crewmember during dynamic phases of flight. The test shall include video motion capture of dynamic event pulse sled testing. Verification shall be considered successful when the analysis shows that crew body movement relative to the seat is less than or equal to what is specified in Appendix N, table Restrained Body Movement and Deflection <TBR-70024-001>.

Rationale: No further rationale is required.

4.2.4.2.8 Flail Injury Protection

[HS5012V] The requirement shall be verified by analysis and test. Analysis shall show that flail motion does not contact rigid hardware that would cause injury during dynamic flight phases. Analysis shall be verified by test, which may include video motion capture

Revision: E	Document No: CxP 70024
Release Date: 11/19/10	Page: 205 of 503
Title: Constellation Program Human-Systems Integration Requirements	

of dynamic event pulse sled testing. The verification shall be considered successful when the analysis shows that the system precludes crewmember limbs from impacting nearby rigid hardware that would cause injury, from hyper-extension, and from fracturing or dislocating of crewmember limbs.

Rationale: No further rationale is required.

4.2.4.3 Rotational Acceleration Limits

4.2.4.3.1 Sustained Rotational Acceleration Limit

[HS3065V] The crew exposure to sustained rotational acceleration shall be verified by analysis supported by test. The analysis shall use a certified simulation to verify all nominal flight phase scenarios. The simulation shall use test data collected from flight tests. In addition nominal flight tests, ascent abort tests, parachute tests, and landing attenuation tests will provide acceleration measures to evaluate vehicle rotational acceleration. Testing will require continuous on-board acquisition (or sampling) of 3D rotational acceleration (yaw, pitch, and roll) on a millisecond timescale. The verification shall be considered successful when the analysis supported by test data indicates that the measured sustained rotational acceleration is no greater than 115 degrees/s².

Rationale: No further rationale is required.

4.2.4.4 Rotational Rates

4.2.4.4.1 Rotational Limits for Nominal Return

[HS3069V] The crew exposure to rotation shall be verified by analysis and test. The test shall consist of flight tests. Nominal flight tests, ascent abort tests, parachute tests, and landing attenuation tests will provide acceleration measures to evaluate vehicle rotational acceleration. Testing will require continuous on-board acquisition (or sampling) of 3D rotational rate at least every 100 ms. The analysis shall use a certified simulation to verify all nominal flight phase scenarios, as well as 3-sigma bounding Monte Carlo studies with dispersed Guidance, Navigation, and Control (GN&C), and vehicle and environmental factors. The verification shall be considered successful when 1) the tests indicate that the measured rotation rate is no greater than the limits in those depicted in HS3071, figure Angular Rate Limits for all tests and 2) the analyses indicate with 99% confidence that the simulated rotation rate is no greater than these same limits.

Rationale: No further rationale is required.

4.2.4.4.2 Rotational Limits for Nominal Return to Mission Destination

[HS3070V] The crew exposure to rotation shall be verified by analysis and test. The test shall consist of flight tests. Nominal flight tests, ascent abort tests, parachute tests, and landing attenuation tests will provide acceleration measures to evaluate vehicle rotational acceleration. Testing will require continuous on-board acquisition (or sampling) of 3D rotational rate at least every 100 ms. The analysis shall use a certified

Revision: E	Document No: CxP 70024
Release Date: 11/19/10	Page: 206 of 503
Title: Constellation Program Human-Systems Integration Requirements	

simulation to verify all nominal flight phase scenarios, as well as 3-sigma bounding Monte Carlo studies with dispersed GN&C, and vehicle and environmental factors. The verification shall be considered successful when 1) the tests indicate that the measured rotation rate is no greater than the limits in those depicted in HS3071, figure Angular Rate Limits for all tests and 2) the analyses indicate with 99% confidence that the simulated rotation rate is no greater than these same limits.

Rationale: No further rationale is required.

4.2.4.4.3 Rotational Limits for Ascent Abort and Off-Nominal Entry

[HS3071V] The crew exposure to rotation shall be verified by analysis supported by test. The analysis shall use a certified simulation to verify all nominal flight phase scenarios, as well as 3-sigma bounding Monte Carlo studies with dispersed GN&C, and vehicle and environmental factors. The simulation shall use test data collected from flight tests. Nominal flight tests, ascent abort tests, parachute tests, and landing attenuation tests will provide acceleration measures to evaluate vehicle rotational acceleration. Testing will require continuous on-board acquisition (or sampling) of 3D rotational rate at least every 100 ms. The verification shall be considered successful when the analyses supported by test data indicate with 99% confidence that the simulated rotation rate is no greater than these same limits.

Rationale: No further rationale is required.

4.2.5 Vibration

4.2.5.1 Limits for Vibration During Dynamic Phases of Flight

[HS3105V] The dynamic phases of flight vibration exposure health limit shall be verified by analysis supported by test. The analysis shall consist of a simulation of the vibration levels at the crew seat (couch), assuming that the couch is a relatively rigid structure. The weighted acceleration shall be calculated in accordance with ISO 2631-1:1997 using the frequency weighting W_d for the X and Y directions, W_k for the Z direction, and a multiplying factor $k=1.4$ in the X and Y directions and $k=1$ in the Z direction (ISO 2631-1:1997, Table 3 and Section 7.2). Test data obtained from ground vibration testing and/or flight tests, parachute tests, and/or entry tests shall be used to support validation of the model and to evaluate vehicle vibration under all dynamic phases of flight. Testing will require on-board acquisition (or sampling) of the seat translational acceleration along the three orthogonal axes, X, Y, and Z on a millisecond timescale to determine the vibration profile. The verification shall be successful when the analysis indicates with 99% confidence (e.g., 3-sigma bounding for Gaussian-distributed Monte Carlo studies with dispersed GN&C, and vehicle and environmental factors) that the vectorial sum of the X, Y, and Z frequency-weighted accelerations between 0.5 and 80 Hz of the rigid crew seat does not exceed the levels and exposure durations in HS3105, table Frequency-Weighted Vibration Limits by Exposure Time During Dynamic Phases.

Rationale: The vibration levels that reach the crew are the result of several factors provided by the launch vehicle, the crew vehicle, connecting structure,

Revision: E	Document No: CxP 70024
Release Date: 11/19/10	Page: 207 of 503
Title: Constellation Program Human-Systems Integration Requirements	

means of vibration attenuation, etc. For cases where the crew is suited, the suit needs to be considered as an integral part of the seat. The resultant vibration levels will likely be too complex to be determined from analysis alone. In order to determine if the vehicle has met the tolerance vibration limit, which is a matter of crew safety, actual flight test data are required to understand what the crew will experience and to provide data for additional analyses given the possibility that the flight test vehicle will not be completely like the actual flight vehicle. The measurement of acceleration is to be made on the crew seat (couch) structure and assumes that the structure is relatively rigid. ISO 2631-1:1997 calls for the measurement of acceleration at the supporting surfaces between a seat and the occupant to account for the effects of any resilient cushion material. The guidelines given for health in ISO 2631-1:1997 are based primarily on the upright seated occupant, not the semi-supine occupant. The measurement is being made on the rigid seat (couch) structure with respect to the body's X, Y, and Z coordinates defined in ISO 2631-1:1997 Figure 1 and in HSIR Appendix C. It is assumed that the occupant will be rigidly coupled to the couch by the restraint system, minimizing any amplification of vibration by the cushion material. The tolerance data collected in the 1960s reported the accelerations of the vibration platform to which the couch was rigidly attached.

4.2.5.2 Vibration Limits During Crew Sleep

[HS3106V] The crew sleep vibration limit requirement shall be verified by analysis supported by test. The analysis shall use test data collected from flight tests to obtain flight vibration profiles of the vehicle's crew compartment after orbital insertion. Testing will require continuous on-board acquisition (or sampling) of translational acceleration in the three orthogonal axes X, Y, and Z on the support surfaces of the crew compartment used for rest areas on a millisecond timescale to determine the vibration profile. The measurement should reflect the average acceleration levels expected to occur during an 8.5-hour sleep period. The recorded test profile shall then drive an analytic simulation of crew compartment vibration. In accordance with International Standards Organization (ISO) Standard 6954:2000, Section 6, the minimum measurement period shall be 2 minutes in case of significant vibration frequency content below 2 Hz. All acceleration measurements shall be weighted in accordance with ISO 6954:2000, Annex A using the frequency weighting W_a (Table A.1). The verification shall be considered successful when the analysis indicates with 99% confidence (e.g., 3-sigma bounding for Gaussian-distributed Monte Carlo studies with dispersed GN&C, and vehicle and environmental factors) that the simulated vibration levels on the support surfaces of the rest areas are less than 0.01 g frequency-weighted rms acceleration in each of the X, Y, and Z axes between 1.0 and 80 Hz for each 2-minute interval during an 8.5-hour crew sleep period.

Rationale: Because the final configuration of the vehicle and equipment will not be known until close to flight, an effective means of ensuring that sustained vibration levels are met is to perform an analysis of compartment vibration using available flight test data.

Revision: E	Document No: CxP 70024
Release Date: 11/19/10	Page: 208 of 503
Title: Constellation Program Human-Systems Integration Requirements	

4.2.5.3 Pre-Launch Vibration Limit to Prevent Motion Sickness

[HS3108V] The pre-launch vibration limit shall be verified by analysis supported by test. The analysis shall use data collected from a flight test to obtain the vibration profile of the vehicle's crew compartment, particularly of the crew seats, on the pad prior to launch. The weighted acceleration shall be calculated in accordance with International Standards Organization (ISO) Standard 2631-1:1997 using the frequency weighting W_f applied in each X, Y, and Z direction (Table 3). Testing will require on-board acquisition (or sampling) of translational acceleration in the three orthogonal axes X, Y, and Z on a millisecond timescale to determine the vibration profile. The recorded test profile shall then drive an analytic simulation of crew compartment vibration. The analysis shall consist of a simulation of the vibration levels at the crew seats. The verification shall be successful when the analysis indicates with 99% confidence (e.g., 3-sigma bounding for Gaussian-distributed Monte Carlo studies with dispersed vehicle and environmental factors) that the simulated vibration level of the crew seats in each of the X, Y, and Z axes does not exceed 0.05 g frequency-weighted rms acceleration between 0.1 to 0.5 Hz for each 10-minute interval during pre-launch.

Rationale: The vibration levels that reach the crew are the result of several factors provided by the launch vehicle, crew vehicle, connecting structure, and natural environment. The resultant vibration levels may be too complex to be determined from analysis alone. In order to determine if the vehicle has met the pre-launch vibration limit, actual flight test data are required to understand what the crew will experience, and to provide data for additional analyses given the possibility that the flight test vehicle will not be completely like the actual flight vehicle.

4.2.6 Acoustics

4.2.6.1 Acoustic Limits for Launch and Entry Phases

4.2.6.1.1 Acoustic Limits for Post-Landing

[HS3134V] The Speech Interference Level (SIL) and A-weighted overall SPL limits shall be verified by test and analysis. Measurements shall be made within the vehicle in the post-landing configuration with GSE, integrated GFE, stowage, vehicle installations, and closeouts installed in the expected configuration. Hardware shall be operated across the expected range of operational settings (including settings corresponding to the expected highest noise levels). Equivalent-continuous sound level, Leq , measurements shall be made within each octave band with center frequencies ranging from 63 Hz to 84 kHz, using a Type 1 integrating-averaging sound level meter, with a 20-second averaging time. The A-weighted overall SPL shall also be measured. Measurements shall be made at expected crewmember head locations. $SIL(4)$ shall be calculated from the measurements. The verification shall be considered successful when measurements show that the maximum $SIL(4)$ for each crewmember head location is 61 dB or less, and the maximum A-weighted overall SPL is 75 dBA or less. If speech communications are expected for a distance greater than 1.7 m (5.5 ft), then the $SIL(4)$

Revision: E	Document No: CxP 70024
Release Date: 11/19/10	Page: 209 of 503
Title: Constellation Program Human-Systems Integration Requirements	

requirement shall be adjusted according to ANSI S12 65-2006 for the appropriate crewmember head-to-head distance for the voice level of "Very Loud" in Figure 1 of ANSI S12 65-2006, and allowing 4 dB for reduced female voice intensity.

Rationale: No further rationale is required.

4.2.6.1.2 Noise Dose Limits for Launch and Entry

[HS3073V] The noise dose limits for launch and entry shall be verified by test and analysis. The noise level as a function of time for the launch, entry, and ascent abort measured at the crewmember's ears shall be determined by flight-testing. The test and analysis shall consist of estimating the noise level as a function of time at the crewmember's ear by combining significant noise sources from estimates of rocket noise and external flow boundary layer noise, and including acoustic insertion losses of acoustic isolation and protective devices. The rocket noise should be determined by test. Acoustic insertion losses of the pressure shell and other materials shall be determined by test. The effectiveness of hearing protection, headsets, and helmets shall be determined by test. Noise levels for the balance of the 24-hour calculation period shall be assumed to be 65 dBA. The verification shall be considered successful when tests and analysis indicate that the 24-hour noise dose associated with launch, entry, and ascent abort predicted at the crewmember's ears is 100% or less.

Rationale: No further rationale is required.

4.2.6.1.3 Impulse Noise Limit for Launch and Entry

[HS3074V] The impulse noise limit for launch and entry shall be verified by test and analysis. The impulse noise level measured at the crewmember's ears shall be determined by flight-testing. The test and analysis shall consist of estimating the impulse noise level at the crewmember's ear by combining significant noise sources and including acoustic insertion losses of acoustic isolation and protective devices. The ignition noise should be determined by test. Acoustic insertion losses of the pressure shell and other materials shall be determined by test. The effectiveness of hearing protection, headsets, and helmets shall be determined by test. Peak-hold sound pressure level measurements shall be made using a Type 1 sound level meter. The frequency response of the sound level meter shall extend to at least 6 Hz at its lower limit. Formal verification is not required for equipment with impulse noises that have peak overall SPLs of less than 110 dB. The verification shall be considered successful when the test and analysis results indicate that the peak overall sound pressure level predicted at the crewmember's ears is less than 140 dB.

Rationale: Significant noise sources consist of pyrotechnics, rocket ignition, and any other impulse noise source potentially greater than 110 dB SPL.

4.2.6.1.4 Hazardous Noise Limit for Launch and Entry

[HS3072V] The hazardous noise limit for launch and entry shall be verified by test and analysis. The maximum noise level measured at the crewmember's ears shall be

Revision: E	Document No: CxP 70024
Release Date: 11/19/10	Page: 210 of 503
Title: Constellation Program Human-Systems Integration Requirements	

determined by flight-testing. The test and analysis shall consist of estimating the maximum sound level at the crewmember's ear by combining significant noise sources from estimates of rocket noise and external flow boundary layer noise and including acoustic insertion losses of acoustic isolation and protective devices. The rocket noise should be determined by test. Acoustic insertion losses of the pressure shell and other materials shall be determined by test. The effectiveness of hearing protection, headsets, and helmets shall be determined by test. The verification shall be considered successful when the tests and analysis indicate that the maximum level predicted at the crewmember's ears is 105 dBA or less during launch, entry, and suited (helmet on, visor down) burn-phases, and 115 dBA or less during launch abort.

Rationale: No further rationale is required.

4.2.6.1.5 Infrasonic Noise Limits

[HS3081V] The Launch and Entry Phases - Infrasonic Noise Limit shall be verified by test and analysis. The maximum noise level measured at the crewmember's ears shall be determined by flight-testing. The test and analysis shall consist of estimating the maximum sound level at the crewmember's ear by combining significant noise sources from estimates of rocket noise and external flow boundary layer noise, and including acoustic insertion losses of acoustic isolation and protective devices. The rocket noise should be determined by test. Acoustic insertion losses of the pressure shell and other materials shall be determined by test. The effectiveness of hearing protection, headsets, and helmets is not allowed for this verification. Sound pressure measurements shall be made over a frequency range from 1 to 20 Hz, using a Type 1 integrating-averaging sound level meter at expected work station head locations. The infrasonic noise level shall be measured via a 20 second Leq (slow time weighting). The verification shall be considered successful when the test and analysis indicate that the unweighted overall sound pressure level is 150 dB or less, at each expected work station head-location.

Rationale: Rocket and aerodynamic sources present during launch, entry, ascent abort and translunar injection or other long duration rocket firings are considered to be the only credible noise sources for this requirement.

4.2.6.2 Acoustic Limits for the Orbit Phase

4.2.6.2.1 Sound Pressure Level (SPL) Limits for Waste Management System

[HS3133V] The Waste Management System (WMS) noise limit shall be verified by test. Sound Pressure Level (SPL) measurements shall be made of the actual flight WMS (each serialized unit) in its flight configuration with closeouts and privacy curtain installed. WMS shall be operated across the expected range of settings, including settings corresponding to the expected highest noise levels. Measurements shall be made using a Type 1 integrating-averaging sound level meter for each flight WMS. Analysis shall be used to include any measured acoustical effects of WMS installation configuration, or to combine measured sound pressure levels of WMS and other

Revision: E	Document No: CxP 70024
Release Date: 11/19/10	Page: 211 of 503
Title: Constellation Program Human-Systems Integration Requirements	

hardware items that must be operated simultaneously, when these factors are not accurately represented in field tests. If the noise generated by WMS is influenced by the operation of another hardware item, then both items shall be tested together. The verification shall be considered successful when the test indicates that the maximum noise levels at the expected user's head position of the WMS, and at crew station head positions in the main habitable volume, meet the level of 68 dBA, or less.

Rationale: No further rationale is required.

4.2.6.2.2 Impulse Noise Limit for the Orbit Phase

[HS3078V] The impulse noise limit shall be verified by test. The SPL measurements for this verification shall be made using the actual flight equipment (each serialized unit). Formal verification is not required for equipment with impulse noises that have peak overall SPLs of less than 100 dB. Peak-hold sound pressure level measurements shall be made using a Type 1 sound level meter on all equipment that emits significant impulse noise at expected head locations. The frequency response of the sound level meter shall extend to at least 6 Hz at its lower limit. Measurement locations relative to specific noise sources must correspond to the shortest distance from the loudest point on the hardware to the closest possible crewmember head location. This verification shall be considered successful when the test results show that the peak overall sound pressure level measurements are less than 120 dB.

Rationale: Serialized units must be verified individually because different units produced from the same design can generate significantly different noise levels. Significant impulse noise sources consist of valves, burst disks, and any other impulse noise source potentially greater than 100 dB SPL. Noise attenuation gained by the use of hearing protection is not to be considered toward the compliance of this requirement, because hearing protection may not always be worn. Intermediate testing and analysis should be performed and reviewed by NASA to ensure confidence that compliance with this requirement will be met and to preclude late impacts to cost, schedule, and hardware.

4.2.6.2.3 Annoyance Noise Limits for Crew Sleep

[HS3079V] The annoyance noise limits shall be verified by test. The measurements shall be made within the vehicle in the flight configuration with integrated Government Furnished Equipment (GFE), portable equipment, payloads, and cargo installed. Hardware shall be operated at settings that occur during crew rest periods. Measurements shall be made at expected sleep station head locations using a Type 1 integrating-averaging sound level meter. Measurement locations shall be no closer than 8 cm from any surface. Peak-hold sound pressure level (impulse noise) and A-weighted Overall SPL measurements shall be made. The verification shall be considered successful when measurements show that the peak overall sound pressure levels are less than 83 dB peak for impulse noise (not weighted) and 70 dBA (A-weighted) for intermittent noise.

Revision: E	Document No: CxP 70024
Release Date: 11/19/10	Page: 212 of 503
Title: Constellation Program Human-Systems Integration Requirements	

Rationale: Intermediate testing and analysis should be performed and reviewed by NASA to ensure confidence that compliance with this requirement will be met and to preclude late impacts to cost, schedule, and hardware.

4.2.6.2.4 Hazardous Noise Limit for the Orbit Phase

[HS3075V] The hazardous noise limit shall be verified by test and analysis. The SPL measurements for this verification shall be made using the actual flight equipment (each serialized unit) including GFE, portable equipment, payloads, and cargo. Sound Pressure Level (SPL) measurements shall be made using a Type 1 integrating-averaging sound level meter for each item of equipment and during all anticipated activities including maintenance. The maximum A-weighted overall SPL (L_{Amax}) with a fast (125 ms) exponentially weighted time averaged response shall be measured. Analysis shall be used to include the effects of reflections, standing waves, or reverberation or to combine measured sound pressure levels of hardware items that will be operated simultaneously when these factors are not accurately represented in the field test. If the noise generated by a specific hardware item is influenced by the operation of another hardware item then these hardware items shall be tested together. The verification shall be considered successful when field testing (and any performed simulations) indicates that the maximum level, measured at any location (no closer than 8 cm to surfaces) within the habitable volume and at any maintenance operation head location, and at the ears of space-suit occupants, is below 85 dBA (L_{Amax}) for any combination of individual hardware items that may occur simultaneously.

Rationale: Serialized units must be verified individually because different units produced from the same design can generate significantly different noise levels. Noise attenuation gained by the use of hearing protection is not to be considered toward the compliance of this requirement because hearing protection may not always be worn. Intermediate testing and analysis should be performed and reviewed by NASA to ensure confidence that compliance with this requirement will be met and to preclude late impacts to cost, schedule, and hardware.

4.2.6.2.5 Sound Pressure Level (SPL) Limits for Continuous Noise during the Orbit Phase

[HS3076V] The continuous noise limit shall be verified by test. The measurements shall be made within the vehicle and space suits in the flight configuration with integrated GFE, stowage, vehicle installations, and closeouts installed. Continuous noise generated by portable equipment, payloads, and cargo shall be assumed to be equivalent to NC-46 and shall be added to the verification measurements. Hardware shall be operated across the expected range of operational settings (including settings corresponding to the expected highest noise levels). Equivalent-continuous sound level, Leq, measurements shall be made within each octave band with center frequencies ranging from 63 Hz to 16 kHz, using a Type 1 integrating-averaging sound level meter with a 20-second averaging time. Measurements shall be made at expected work and sleep station head locations, as well as throughout the habitable volume, to

Revision: E	Document No: CxP 70024
Release Date: 11/19/10	Page: 213 of 503
Title: Constellation Program Human-Systems Integration Requirements	

determine a spatial average of other potential crew head locations. Measurement locations shall be no closer than 30 cm from each other and no closer than 8 cm from any surface, and at the ears of space-suit occupants. The spatial average shall be based on incoherent sound power addition (i.e., average of pressure-squared values). The verification shall be considered successful when field testing indicates that

a. the measured L_{eq} at each expected work and sleep station head location (ear location of suited crew) and the estimated center of the habitable volume do not exceed the levels within each octave band indicated in HS3076, table Octave Band Sounds Pressure Level Limits.

b. the spatially-averaged SPLs (average of pressure-squared values) throughout the habitable volume do not exceed the levels given in HS3076, table Octave Band Sounds Pressure Level Limits. The spatial average shall include locations used in 1) above, and a sufficient number of additional locations, to achieve a ± 2 dB 90% confidence interval within each octave band from 250 Hz to 16 kHz (see HS3076V, figure Number of Measurements vs. Standard Deviation to Determine $A \pm 2$ dB 90% Confidence Interval).

c. no octave band sound pressure level measured at any location or at the maximum level location (i.e., the location of the maximum A-weighted overall sound pressure level found with a handheld sound level meter) within the entire habitable volume is more than 4 dB above the levels specified in HS3076, table Octave Band Sound Pressure Level Limits at the corresponding octave-band center frequency.

Rationale: Lower nominal settings of major hardware components shall also be tested and documented because expected maximum operational settings may not correspond to the highest noise levels. Noise attenuation gained by the use of hearing protection is not to be considered toward the compliance of this requirement because hearing protection may not always be worn. Intermediate testing and analysis should be performed and reviewed by NASA to ensure confidence that compliance with this requirement will be met and to preclude late impacts to cost, schedule, and hardware.

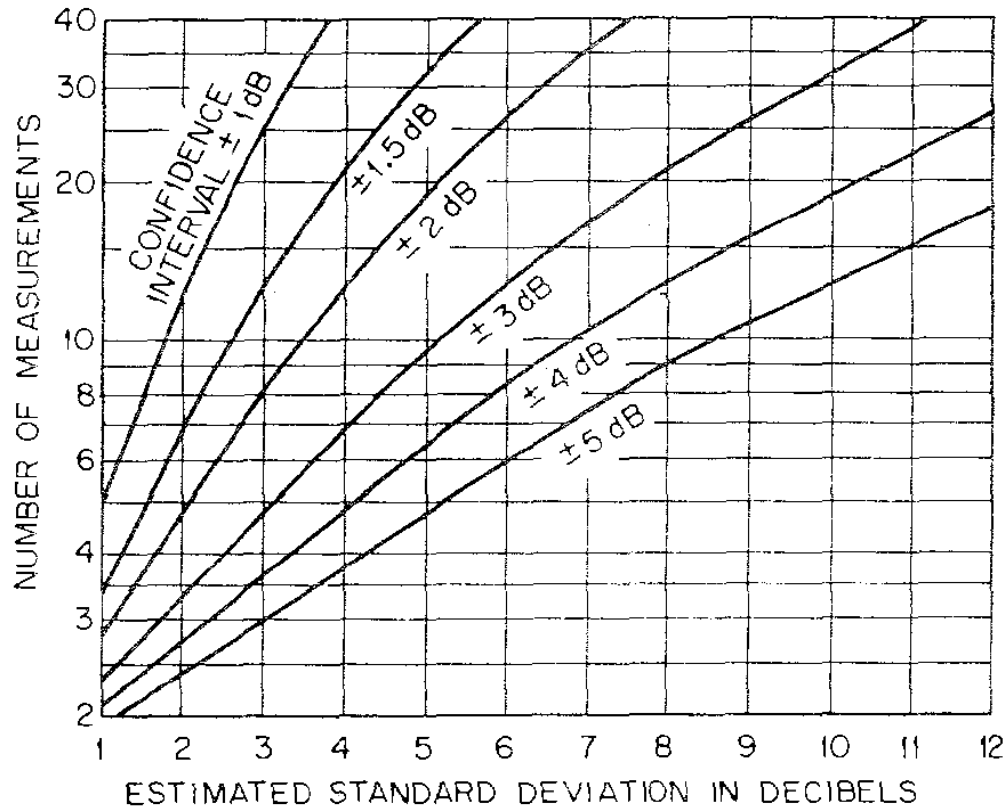


FIGURE 4.2.6.2.5-1 - NUMBER OF MEASUREMENTS VS, STANDARD DEVIATION TO DETERMINE A ± 2 DB 90% CONFIDENCE INTERVAL (FROM "ACOUSTICAL MEASUREMENTS AND NOISE CONTROL" BY C. M. HARRIS, P. 9.9, FIGURE 9.7)

4.2.6.2.6 Sound Pressure Level (SPL) Limits for Intermittent Noise during the Orbit Phase

[HS3109V] The intermittent noise shall be verified by test and analysis. Sound Pressure Level (SPL) measurements shall be made of the actual flight hardware (each serialized unit) in its flight configuration with closeouts installed. Verification measurements may be performed on hardware items individually (i.e. as tested in an acoustic chamber), or integrated into the flight vehicle (e.g. for integrated hardware such as thrusters). Hardware shall be operated across the expected range of settings, including settings corresponding to the expected highest noise levels. Measurements shall be made using a Type 1 integrating-averaging sound level meter for each item of equipment indicated in HS3109, table Approved Intermittent Noise Sources. The maximum A-weighted overall SPL (L_{Amax}) shall be measured with a fast (125 ms) exponentially-weighted time-averaged response. Analysis shall be used to include any measured or predicted acoustical effects of the hardware installation configuration or to combine measured sound pressure levels of hardware items that must be operated simultaneously when these factors are not accurately represented in field tests. If the

Revision: E	Document No: CxP 70024
Release Date: 11/19/10	Page: 215 of 503
Title: Constellation Program Human-Systems Integration Requirements	

noise generated by a specific hardware item is influenced by the operation of another hardware item, then these hardware items shall be tested together. Analysis shall also be used to calculate the maximum operational duration to include the total time during any 24-hour period that the hardware item operates above the continuous noise limits given in HS3076, table Octave Band Sounds Pressure Level Limits. This verification shall be considered successful when the test (and any performed simulations) indicates that the maximum noise level for the duration of intermittent operation, meets the level and duration limits specified in HS3109, table Intermittent Noise A-Weighted Overall Sound Pressure Level and Corresponding Operational Duration Limits (Measured at 0.6 m) as measured either at 0.6 m or at the closest expected crew head-location from the loudest point on the hardware surface (at least 0.6 m from any habitable volume surface).

Rationale: Serialized units must be verified individually because different units produced from the same design can generate significantly different noise levels. Noise attenuation gained by the use of hearing protection is not to be considered toward the compliance of this requirement because hearing protection may not always be worn. Intermediate testing and analysis should be performed and reviewed by NASA to ensure confidence that compliance with this requirement will be met and to preclude late impacts to cost, schedule, and hardware. Prototype or qualification units should be tested prior to manufacture of the actual flight equipment.

4.2.6.2.7 Tonal and Narrow-Band Noise Limits

[HS3080V] The tonal and narrow-band noise limit shall be verified by test. The measurements shall be made within the vehicle in the flight configuration with integrated GFE, stowage, vehicle installations, and closeouts installed. Hardware shall be operated across the expected range of operational settings (including settings corresponding to the expected highest noise levels). Equivalent-continuous sound level, Leq, measurements shall be made within each octave band, with center frequencies ranging from 63 Hz to 16 kHz, using a Type 1 integrating-averaging sound level meter with a 20-second averaging time. Tonal and narrow-band component measurements shall also be made using a Fast Fourier Transform (FFT) with a frequency resolution of 1 Hz. Measurements shall be made at expected work and sleep station head locations. The verification shall be considered successful when the test indicates that the maximum levels of tones and narrow band components, measured at all work and sleep station head locations, is at least 10 dB less than the value in the [HS3076], table Octave Band Sound Pressure Level Limits of the octave band that contains the component or tone for the 1-, 2-, 4-, and 8-kHz octave bands and at least 5 dB less than the value in the [HS3076], table Octave Band Sound Pressure Level Limits of the octave band that contains the component or tone for the 63-, 125-, 250-, and 500-Hz octave bands at the same location.

Rationale: No further rationale is required.

Revision: E	Document No: CxP 70024
Release Date: 11/19/10	Page: 216 of 503
Title: Constellation Program Human-Systems Integration Requirements	

4.2.6.3 All Flight Phases

4.2.6.3.1 Cabin Depressurization Valve Hazardous Noise Limit

[HS3082V] The cabin depressurization valve hazardous noise limit shall be verified by test and analysis. The test and analysis shall consist of estimating the maximum sound level at the crewmember's ear by combining significant noise sources from estimates of valve noise and including acoustic insertion losses of protective devices. The pressure-relief valve noise shall be determined by test. If allowed, the effectiveness of hearing protection, headsets, and helmets shall be determined by test. The verification shall be considered successful when tests and analysis indicate that, during pressure relief valve operations, the maximum level predicted at the crewmember's ears is 105 dBA or less.

Rationale: No further rationale is required.

4.2.6.3.2 Cabin Depressurization Valve Noise Dose Limits

[HS3083V] The cabin depressurization valve - noise dose limit shall be verified by test and analysis. The test and analysis shall consist of estimating the noise level as a function of time at the crewmember's ear by combining significant noise sources from estimates of valve noise and including acoustic insertion losses of protective devices. The pressure-relief valve noise shall be determined by test. If allowed, the effectiveness of hearing protection, headsets, and helmets shall be determined by test. Noise levels for the balance of the 24-hour calculation period shall be assumed to be 65 dBA. The verification shall be considered successful when tests and analysis indicate that the 24-hour noise dose, associated with pressure valve releases, predicted at the crewmember's ears is 100% or less.

Rationale: No further rationale is required.

4.2.6.3.3 Reverberation Time

[HS3084V] The reverberation time limit shall be verified by test and analysis. Field testing shall be used to measure the reverberation time inside the actual flight vehicle. The methodology given in ISO 3382, "Measurement of the Reverberation Time of Rooms with Reference to Other Acoustical Parameters," shall be used. The test and analysis shall be considered successful when the reverberation time is less than 0.6 second in the 500-Hz, 1-kHz, and 2-kHz octave bands.

Rationale: Intermediate testing and analysis should be performed and reviewed by NASA to ensure confidence that compliance with this requirement will be met and to preclude late impacts to cost, schedule, and hardware.

4.2.6.3.4 Noise Limit for Personal Communication Devices

[HS3110V] The personal communication device SPL limit shall be verified by test. Measurements shall be made using a Type 1 integrating-averaging sound level meter

Revision: E	Document No: CxP 70024
Release Date: 11/19/10	Page: 217 of 503
Title: Constellation Program Human-Systems Integration Requirements	

with an artificial ear or head simulator. The verification shall be considered successful when the test shows that the measured maximum SPL at the crewmember's ear is 115 dBA or less at maximum specified device audio input level and the maximum audio output volume setting.

Rationale: No further rationale is required.

4.2.6.3.5 Loudspeaker Alarm Audibility

[HS3111V] The loudspeaker nonspeech auditory annunciation levels shall be verified by test. The measurements shall be made within the vehicle in the flight configuration with integrated GFE, stowage, vehicle installations, and closeouts installed. Hardware shall be operated across the expected range of operational settings (including settings corresponding to the expected highest noise levels). Sound pressure measurements shall be made within each one-third-octave band, with center frequencies ranging from 300 Hz to 3 kHz, using a Type 1 integrating-averaging sound level meter using a peak hold function with a fast (125 ms) exponentially-weighted time averaged response. Measurements shall be made at expected work and sleep station head locations. The ambient noise level shall be measured via a 20-second Leq (slow time weighting). The verification shall be considered successful when the test indicates that, for each temporal component of the annunciation, the level in at least one one-third-octave band is more than 13 dB above the ambient noise level at each expected work and sleep station location.

Rationale: No further rationale is required.

4.2.7 Ionizing Radiation

4.2.7.1 Radiation Design Requirements

4.2.7.1.1 Radiation Design Requirements

[HS3085V] Radiation exposure shall be verified by analysis. The analysis shall be performed through the use of a model with the following components: Design Environment: CxP 70023, DSNE, Section 3.3.4. Transport code: The HZETRN_2005 code provided as GFE by CxP. Vehicle Geometry: CFE CxP standard Computer Aided Drafting (CAD) model of the vehicle structure, hardware, stowage, and CFE equipment. This includes materials specification sufficient to derive chemical composition and bulk density for each instance/part in the design. The vehicle as analyzed shall be representative of a standard lunar transit configuration for vehicle components, equipment and stowage items as well as a minimum crew complement placed within the habitable volume. Shield Evaluation/Mass Distribution Evaluation: Barrier Thickness Evaluator (BTE) code provided as GFE by CxP.

Human Geometry: 50th percentile Computerized Anatomical Female (CAF) model provided as GFE by CxP. Analysis locations within the human body and mass distribution solid angle distributions also provided for analysis as GFE by CxP.

Revision: E	Document No: CxP 70024
Release Date: 11/19/10	Page: 218 of 503
Title: Constellation Program Human-Systems Integration Requirements	

The verification shall be considered successful when the analysis shows that the maximum effective dose incurred by any crewmember within the vehicle does not exceed the value given in HS3085, table System-Specific Radiation Design Requirements.

Effective dose shall be calculated as a quantity,

$$E = \sum_T w_T H_T$$

where the equivalent dose, H_T , is defined as

$$H_T = Q(L)D_{T,R}$$

$D_{T,R}$ is the dose averaged over a specific organ or tissue (T) due to radiation (R).

The tissue weighting factor w_T is given in Table 4.3, for required tissues/organs, in National Council on Radiation Protection and Measurements (NCRP) Report Number 132.

$Q(L)$ is the radiation quality factor as a function of same as specified in National Council on Radiation Protection and Measurements (NCRP) Report Number 132, Table 4.2 Q vs. L relationship, Radiation Protection Guidance for Activities in Low-Earth Orbit.

Rationale: Analysis must be used to verify this requirement. The complexity of radiation environment, radiation transport calculations, and vehicle/shielding geometry make verification by other methods intractable. Selection of calculation inputs and algorithms follow a conservative approach and the calculation methods are state of the art for space radiation analysis.

4.2.7.2 Active Radiation Monitoring

4.2.7.2.1 Charged Particle Monitoring

[HS3086V] Charged particle monitoring shall be verified by test and analysis for detector integration into the vehicle. The test shall use one flight equivalent instrument to verify the requirement. The test shall use accelerator sources of charged particles with $Z=1, 2, 6, 8, 14,$ and 26 . The test shall use two energies within 30 to 300 MeV/nucleon for $Z<3$. The test shall use two energies within 100 to 400 MeV/nucleon for $3\leq Z\leq 26$. The test shall use a total fluence of not less than $100,000 \text{ cm}^{-2}$ delivered at a fluence rate range $500 \text{ cm}^{-2} \text{ s}^{-1}$ to $1,000 \text{ cm}^{-2} \text{ s}^{-1}$ for $2<Z<26$ and a total fluence of $100,000 \text{ cm}^{-2}$ delivered at a fluence rate no smaller than $2,000 \text{ cm}^{-2} \text{ s}^{-1}$ for $Z=1$. The analysis shall use a geometrical assessment of the CAD vehicle model to verify the unobstructed viewing angle requirement. The verification shall be considered successful when the test shows agreement with reference fluence within $\pm 10\%$, with an energy resolution $<30\%$ and when the analysis shows an unobstructed viewing angle not less than 1.1345 radians (65 degrees).

Revision: E	Document No: CxP 70024
Release Date: 11/19/10	Page: 219 of 503
Title: Constellation Program Human-Systems Integration Requirements	

Rationale: Test is the necessary method for verification of this requirement. The verification cannot be performed for all components of the space radiation field in which the vehicle will be exposed. The selected test fields span the range of the Z, energy, Linear Energy Transfer, fluence, and fluence rates expected during the missions.

4.2.7.2.2 Dose Equivalent Monitoring

[HS3088V] Dose equivalent monitoring shall be verified by test. The test shall use one flight equivalent instrument to verify the requirement. The test shall be an exposure of the flight equivalent instrument to radiation sources. The test shall use accelerator sources of charged particles with Z=1, 6, and 26. The test shall use Cesium-137 or Cobalt-60 photon source. Each radiation source shall deliver a total dose equivalent of 10 mSv for each of the dose equivalent ranges of 0.5 mSv per hour to 3 mSv per hour and 5 mSv per hour to 10 mSv per hour. The verification shall be considered successful when the test shows $\pm 20\%$ agreement between the measured and reference dose equivalent rate and total dose equivalent.

Rationale: Test is the necessary method for verification of this requirement. Instrument operation cannot be simulated or inspected. Exposure to actual radiation fields is required to verify that the instrument is operational and that it meets design specifications. The verification cannot be performed for all components of the space radiation field to which the vehicle will be exposed. The selected test fields span the range of the Z, energy, linear energy transfer, dose equivalents, and dose equivalent rates expected during the missions, including radiation fields expected during solar particle events.

4.2.7.2.3 Absorbed Dose Monitoring

[HS3089V] Absorbed dose monitoring shall be verified by test. The test shall use one flight equivalent instrument to verify the requirement. The test shall be an exposure of the flight equivalent instrument to radiation sources. The test shall use accelerator sources of charged particles with Z =1, 6, and 26. Each radiation source shall deliver a total dose of 10 mGy for each of the dose equivalent ranges of: 0.5 mGy per hour to 3 mGy per hour and 5 mGy per hour to 10 mGy per hour. The verification shall be considered successful when the test shows $\pm 20\%$ agreement between the measured and reference dose rate and total dose.

Rationale: Test is the necessary method for verification of this requirement. Instrument operation cannot be simulated or inspected. Exposure to actual radiation fields is required to verify that the instrument is operational and that it meets design specifications. The verification cannot be performed for all components of the space radiation field to which the vehicle will be exposed. The selected test fields span the range of the Z, energy, Linear Energy Transfer, absorbed doses, and absorbed dose rates expected during the missions, including radiation fields expected during solar particle events.

Revision: E	Document No: CxP 70024
Release Date: 11/19/10	Page: 220 of 503
Title: Constellation Program Human-Systems Integration Requirements	

4.2.7.3 Passive Radiation Monitoring

4.2.7.3.1 Passive Radiation Monitoring

[HS3090V] Passive dosimetry to measure radiation exposure in CxP vehicles/elements shall be verified by inspection and analysis. The analysis shall determine the number and placement of measuring devices within the vehicle/element based on the interior configuration. The inspection shall consist of a drawing review to confirm the number and the attach point locations of the devices in the vehicle interior. The verification shall be considered successful when the inspection confirms that the system provides a minimum of six locations with passive radiation dosimeters attached to the interior of each pressurized vehicle/element.

Rationale: Analysis must be used to verify this requirement. The complexity of radiation environment, radiation transport calculations, and vehicle/shielding geometry make verification by other methods intractable. Selection of attach points will be based on the projected radiation exposures, using transport calculation and vehicle geometry, within the vehicle given in DRD T-045, Space Radiation Analysis and Certification Report.

4.2.7.4 Reporting Radiation Data

4.2.7.4.1 Radiation Data Reporting to the Crew - Absorbed Dose

[HS3091V] The absorbed dose data reporting shall be verified by test. The test shall use one flight equivalent instrument to take the measurements. The test shall use the vehicle data management system or equivalent to receive the measurements. The test will be a simulated operational session of measurements taken by the flight equivalent instrument interfaced to the data management system or equivalent. The test shall be a 1-hour measurement. The test shall be considered successful when the data reported to the vehicle data management system or equivalent are updated every 1 minute and the time tag on the data reported is less than 5 minutes older than actual time when the data were recorded.

Rationale: Test is the necessary method for verification of this requirement. The instrument interface to the data management system or equivalent must be tested with the actual hardware to ensure that the instrument is passing data that can be recorded correctly.

4.2.7.4.2 Radiation Data Reporting to the Crew - Dose Equivalent

[HS3119V] The dose equivalent data reporting shall be verified by test. The test shall use one flight equivalent instrument to take the measurements. The test shall use the vehicle data management system or equivalent to receive the measurements. The test will be a simulated operational session of measurements taken by the flight equivalent instrument interfaced to the data management system or equivalent. The test shall be a 1-hour measurement. The test shall be considered successful when the data reported to the vehicle data management system or equivalent are updated every 1 minute and

Revision: E	Document No: CxP 70024
Release Date: 11/19/10	Page: 221 of 503
Title: Constellation Program Human-Systems Integration Requirements	

the time tag on the data reported is less than 5 minutes older than the actual time when the data were recorded.

Rationale: Test is the necessary method for verification of this requirement. The instrument interface to the data management system or equivalent must be tested with the actual hardware to ensure that the instrument is passing data that can be recorded correctly.

4.2.7.4.3 Radiation Data Reporting to Missions Systems - Absorbed Dose

[HS3112V] The absorbed dose data reporting shall be verified by test. The test shall use one flight equivalent instrument to take the measurements. The test shall use the vehicle data management system or equivalent to receive the measurements. The test shall use Mission operations or equivalent. The test will be a simulated operational session of measurements taken by the flight equivalent instrument interfaced to the data management system or equivalent and Mission operations or equivalent. The test shall be a 4-hour measurement and transmission. The test shall be considered successful when the received data are updated every minute, time tag on data received is less 5 minutes older than actual time, and when the data received are transmitted.

Rationale: Test is the necessary method for verification of this requirement. The instrument interface to the data management system or equivalent and Mission Systems must be tested with the actual hardware to ensure that the instrument is passing data that can be reported correctly.

4.2.7.4.4 Radiation Data Reporting to Mission Systems - Dose Equivalent

[HS3120V] The dose equivalent data reporting shall be verified by test. The test shall use one flight equivalent instrument to take the measurements. The test shall use the vehicle data management system or equivalent to receive the measurements. The test shall use Mission operations or equivalent. The test will be a simulated operational session of measurements taken by the flight equivalent instrument interfaced to the data management system or equivalent and Mission Operations or equivalent. The test shall be a 4-hour measurement and transmission. The test shall be considered successful when the received data are updated every minute, time tag on data received is less 5 minutes older than actual time, and when the data received are transmitted.

Rationale: Test is the necessary method for verification of this requirement. The instrument interface to the data management system or equivalent and Mission Systems must be tested with the actual hardware to ensure that the instrument is passing data that can be reported correctly.

4.2.7.4.5 Particle Archive Data

[HS3113V] Data archival shall be verified by test and analysis. The test shall use each flight equivalent instrument used to make charged particle, dose equivalent, absorbed dose, measurements. The test shall use the vehicle data management system or equivalent to receive the measurements. The test shall use Mission Operations or

Revision: E	Document No: CxP 70024
Release Date: 11/19/10	Page: 222 of 503
Title: Constellation Program Human-Systems Integration Requirements	

equivalent. The test will be a simulated operational session of measurements taken and recorded by the flight equivalent instruments interfaced to the data management system or equivalent and Mission Operations or equivalent. The test shall be a 1-day measurement and subsequent transmission of archival data. The test shall be considered successful when the data received by Mission Operations are confirmed to be identical to the recorded data. The analysis shall use a data set from each of the flight equivalent instruments equivalent to the data generated during flight operation. The analysis shall be considered successful when the total memory allocation for each flight equivalent instrument is shown to be larger than the mission data set size of the longest Design Reference Mission (DRM).

Rationale: Test is the necessary method for verification of this requirement. The instrument interface to the data management system or equivalent and Mission Systems must be tested with the actual hardware to ensure that the instrument is passing archive data that can be downlinked correctly. The integrity of the real acquired data must be confirmed to ensure that data corruption is not occurring during the downlink.

4.2.7.5 Alerting for Radiation Data

4.2.7.5.1 Alerting for Radiation Data

[HS3092V] The absorbed dose alerting shall be verified by demonstration. The demonstration shall consist of setting thresholds at 0.02 mGy/min, 0.05 mGy/min, 1 mGy/min, and 10 mGy/min. The demonstration shall use a simulated data stream identical format to the absorbed dose data stream, input into the vehicle data management system, or equivalent, that will exceed each of the above thresholds for three consecutive readings. The verification shall be considered successful when the demonstration shows that an alert in the vehicle data management system is generated when each of these thresholds is exceeded for three consecutive readings.

Rationale: Demonstration is the necessary method for verification of this requirement. Due to the high dose rates required to exceed the alarm thresholds, it is not practical to use a flight equivalent instrument as the data source. The data stream will be simulated with data identical to the absorbed dose data format. Confirmation of the various alarm threshold settings and ability to generate an alarm if they are exceeded is important to ensure reliability of the alarm function and protect crewmembers during high dose rate conditions. The alarm testing does not require analysis but will verify an alarm or no alarm condition.

4.2.8 Non-Ionizing Radiation (NIR)

Revision: E	Document No: CxP 70024
Release Date: 11/19/10	Page: 223 of 503
Title: Constellation Program Human-Systems Integration Requirements	

4.2.8.1 Radio-Frequency Electromagnetic (EM) Field Radiation Limits

4.2.8.1.1 Radio-Frequency Electromagnetic Field Radiation Limits

[HS3093V] Crew exposure to radio-frequency electromagnetic fields shall be verified by analysis. Data generated in response to the CxP E3 verification test requirements (CxP 70080, Constellation Program Electromagnetic Environmental Effects (E3) Requirements Document) shall be analyzed and verified both for individual and combined RF EM fields. A model of additive and synergistic RF EM fields shall be generated to show projected crew exposures in crew accessible areas, both internal and external to the vehicle. The verification shall be considered successful when the analysis shows crew exposures are within the limits specified in Appendix C Table C3-1 and Figure C3-1.

Rationale: The test which provides the data for this verification analysis is the same type of testing which is normally performed to determine EM field effects with regard to avionics hardware. Analysis must be performed using this test data to synthesize the exact characteristics of each individual field produced, as well as the combined EM field environment, with regard to exposure levels for the crew. NOTE: Drive Electromagnetic Interference (EMI) Team to do assessments for humans in addition to the equipment.

4.2.8.2 Laser Radiation Limits

4.2.8.2.1 Ocular Exposure to Lasers

[HS3094V] Ocular exposure from laser systems shall be verified by analysis. The analysis shall be performed as defined by American National Standards Institute (ANSI) standard, ANSI Z136.1, 2007 American National Standard for Safe Use of Lasers. The verification shall be considered successful when the analysis shows that ocular exposure is within the limits in ANSI Z136.1, 2007 Tables 5a and 5b without protective equipment.

Rationale: Analysis must be used to verify this requirement. To prove that the ANSI standard is met, the laser system must be analyzed with regard to its operating parameters, operational configuration, and isolation and containment measures. Protective equipment as defined by the ANSI standard is, "...protection in the form of goggles or spectacles, barriers, windows, clothing and gloves, and other devices which have been specifically selected for suitable protection against laser radiation." (p. 42, Section 4.6.1)

4.2.8.2.2 Dermal Exposure to Lasers

[HS3096V] Limiting skin exposure to laser systems shall be verified by analysis. The analysis shall be performed as defined by ANSI Z136.1, 2007. The verification shall be considered successful when the analysis shows that dermal exposure is within the limits in ANSI Z136.1, 2007 Table 7 without protective equipment.

Revision: E	Document No: CxP 70024
Release Date: 11/19/10	Page: 224 of 503
Title: Constellation Program Human-Systems Integration Requirements	

Rationale: Analysis must be used to verify this requirement. To prove that the ANSI standard is met, the laser system must be analyzed with regard to its operating parameters, operational configuration, and isolation and containment measures. Protective equipment as defined by the ANSI standard is, "protection in the form of goggles or spectacles, barriers, windows, clothing and gloves, and other devices which have been specifically selected for suitable protection against laser radiation." (p. 42, Section 4.6.1).

4.2.8.3 Incoherent Radiation Limits

4.2.8.3.1 Retinal Thermal Injury from Visible and Near Infrared Sources

4.2.8.3.1.1 Retinal Thermal Injury from Visible and Near Infrared Sources

[HS3098V] Crewmember exposure limits shall be verified by test and analysis. The test shall measure the transmittance of all transparent and translucent apertures and radiance of artificial sources from at least 385–1,400 nm in 1-nm increments. Transmittance measurements may be taken using witness samples in the normal flight configuration if the witness samples are large enough to capture the enhanced transmittance realized from multi-pane reflections; otherwise, transmittance measurements shall be performed on flight articles. Spectral radiance measurements of artificial sources shall be done by type and lot. The test report shall be provided to NASA, including the transmittance and radiance data, along with a graphical representation of these data. The analysis shall include calculation of the limits indicated in the requirement using the transmittance and radiance values obtained during the test. The verification shall be considered successful when the analysis shows that the limits calculated from the equations in this requirement are maintained within the applicable spectrum (385–1,400 nm).

Rationale: Test and analysis are required for verification of this requirement, as over this specified range several different damage mechanisms come into play. A full spectral test is required in the defined increments to assure that the equipment under test does not exhibit narrow spectral peaks in radiance or transmittance. Each specified product resulting from the testing is necessary for verification of this requirement as well as other requirements in this section. Analysis is required to integrate individual elements that may contribute to the concentration or attenuation of NIR. A witness sample is a portion of material that is processed at the same time and under the same conditions as the end item product.

4.2.8.3.2 Retinal Photochemical Injury from Visible Light

4.2.8.3.2.1 Small Source Visible Radiation Limits

[HS3099V] Crewmember exposure limits shall be verified by test and analysis. The test shall measure the transmittance of all transparent and translucent apertures and radiance of artificial sources from at least 305–700 nm in 1-nm increments. Transmittance measurements may be taken using witness samples in the normal flight

Revision: E	Document No: CxP 70024
Release Date: 11/19/10	Page: 225 of 503
Title: Constellation Program Human-Systems Integration Requirements	

configuration if the witness samples are large enough to capture the enhanced transmittance realized from multi-pane reflections; otherwise, transmittance measurements shall be performed on flight articles. Spectral radiance measurements of artificial sources shall be done by type and lot. The test report shall be provided to NASA, including the transmittance and radiance data, along with a graphical representation of these data. The analysis shall include calculation of the limits indicated in the requirement using the transmittance and radiance values obtained during the test. The verification shall be considered successful when the analysis shows that the limits calculated from the equations in this requirement are maintained within the applicable spectrum (305–700 nm).

Rationale: Test and analysis are required for verification of this requirement because several different damage mechanisms come into play over this specified range. A full spectral test is required in the defined increments to assure that the equipment under test does not exhibit narrow spectral peaks in radiance or transmittance. Each specified product resulting from the testing is necessary for verification of this requirement, as well as other requirements in this section. Analysis is required to integrate individual elements that may contribute to the concentration or attenuation of NIR. A witness sample is a portion of material that is processed at the same time and under the same conditions as the end item product.

4.2.8.3.2.2 Large Source Visible Radiation Limits

[HS3101V] Crewmember exposure limits shall be verified by test and analysis. The test shall measure the transmittance of all transparent and translucent apertures and radiance of artificial sources from at least 305–700 nm in 1-nm increments. Transmittance measurements may be taken using witness samples in the normal flight configuration if the witness samples are large enough to capture the enhanced transmittance realized from multi-pane reflections; otherwise, transmittance measurements shall be performed on flight articles. Spectral radiance measurements of artificial sources shall be done by type and lot. The test report shall be provided to NASA, including the transmittance and radiance data, along with a graphical representation of these data. The analysis shall include calculation of the limits indicated in the requirement using the transmittance and radiance values obtained during the test. The verification shall be considered successful when the analysis shows that the limits calculated from the equations in this requirement are maintained within the applicable spectrum (305–700 nm).

Rationale: Test and analysis are required for verification of this requirement because several different damage mechanisms come into play over this specified range. A full spectral test is required in the defined increments to assure that the equipment under test does not exhibit narrow spectral peaks in radiance or transmittance. Each specified product resulting from the testing is necessary for verification of this requirement, as well as other requirements in this section. Analysis is required to integrate individual elements that may contribute to the

Revision: E	Document No: CxP 70024
Release Date: 11/19/10	Page: 226 of 503
Title: Constellation Program Human-Systems Integration Requirements	

concentration or attenuation of NIR. A witness sample is a portion of material that is processed at the same time and under the same conditions as the end item product.

4.2.8.3.3 Thermal Injury from Infrared Radiation

4.2.8.3.3.1 Thermal Injury from Infrared Radiation

[HS3103V] Crewmember exposure limits shall be verified by test and analysis. The test shall measure the transmittance of all transparent and translucent apertures and radiance of artificial sources from at least 770–3,000 nm in 1-nm increments. Transmittance measurements may be taken using witness samples in the normal flight configuration if the witness samples are large enough to capture the enhanced transmittance realized from multi-pane reflections; otherwise, transmittance measurements shall be performed on flight articles. Spectral radiance measurements of artificial sources shall be done by type and lot. The test report shall be provided to NASA, including the transmittance and radiance data, along with a graphical representation of these data. The analysis shall include calculation of the limits indicated in the requirement using the transmittance and radiance values obtained during the test. The verification shall be considered successful when the analysis shows that the limits calculated from the equations in this requirement are maintained within the applicable spectrum (770–3,000 nm).

Rationale: Test and analysis are required for verification of this requirement because several different damage mechanisms come into play over this specified range. A full spectral test is required in the defined increments to assure that the equipment under test does not exhibit narrow spectral peaks in radiance or transmittance. Each specified product resulting from the testing is necessary for verification of this requirement, as well as other requirements in this section. Analysis is required to integrate individual elements that may contribute to the concentration or attenuation of NIR. A witness sample is a portion of material that is processed at the same time and under the same conditions as the end item product.

4.2.8.3.4 Ultraviolet Exposure for Unprotected Eye or Skin

4.2.8.3.4.1 Ultraviolet Exposure for Unprotected Eye or Skin

[HS3104V] Crewmember exposure limits shall be verified by test and analysis. The test shall measure the transmittance of all transparent and translucent apertures and radiance of artificial sources from at least 180–400 nm in 1-nm increments. Transmittance measurements may be taken using witness samples in the normal flight configuration if the witness samples are large enough to capture the enhanced transmittance realized from multi-pane reflections; otherwise, transmittance measurements shall be performed on flight articles. Spectral radiance measurements of artificial sources shall be done by type and lot. The test report shall be provided to NASA, including the transmittance and radiance data, along with a graphical

Revision: E	Document No: CxP 70024
Release Date: 11/19/10	Page: 227 of 503
Title: Constellation Program Human-Systems Integration Requirements	

representation of these data. The analysis shall include calculation of the limits indicated in the requirement using the transmittance and radiance values obtained during the test. The verification shall be considered successful when the analysis shows that the limits calculated from the equations in this requirement are maintained within the applicable spectrum (180–400 nm).

Rationale: Test and analysis are required for verification of this requirement because different damage mechanisms come into play over this specified range several. A full spectral test is required in the defined increments to assure that the equipment under test does not exhibit narrow spectral peaks in radiance or transmittance. Each specified product resulting from the testing is necessary for verification of this requirement, as well as other requirements in this section. Analysis is required to integrate individual elements that may contribute to the concentration or attenuation of NIR. A witness sample is a portion of material that is processed at the same time and under the same conditions as the end item product.

4.3 SAFETY

4.3.1 Emergency Equipment Access

4.3.1.1 Emergency Equipment Access

[HS4022V] Emergency equipment access shall be verified by analysis. The analysis shall identify all emergency equipment that is required to address emergencies and their location within the vehicle. The analysis shall determine the time needed to access each piece of emergency equipment per the specific emergency scenario. The verification shall be considered successful when the analysis shows that emergency equipment can be accessed within the time required to address the emergency.

Rationale: No further rationale is required.

4.3.2 Mechanical Hazards

4.3.2.1 Corners and Edges Exposed During Nominal Operations

[HS4002V] Corner and edge rounding for exposure during nominal operations shall be verified by analysis and inspection. The analysis shall determine the location of corners and edges to which the crew or ground personnel are expected to be exposed during nominal operations. The inspection shall consist of inspection of drawings of the identified corners and edges, and physical inspection of the edges using a glove or swatch cloth. The verification shall be considered successful when the analysis and inspection show that corners and edges meet the roundness specifications in Appendix D, table Corner and Edge Rounding Requirements.

Rationale: No further rationale is required.

Revision: E	Document No: CxP 70024
Release Date: 11/19/10	Page: 228 of 503
Title: Constellation Program Human-Systems Integration Requirements	

4.3.2.2 Corners and Edges Exposed During Maintenance

[HS4003V] Corner and edge rounding for exposure during maintenance shall be verified by analysis and inspection. The analysis shall determine the location of corners and edges to which the crew is expected to be exposed during in-flight maintenance. The inspection shall consist of inspection of drawings of the identified corners and edges and a sharp edge inspection. The verification shall be considered successful when the analysis and drawing inspection show that corners and edges are rounded to at least 0.01 inch and the sharp edge inspection identifies no issues.

Rationale: No further rationale is required.

4.3.2.3 Corners and Edges of Loose Equipment

[HS4004V] Loose equipment corner and edge rounding shall be verified by analysis and inspection. The analysis shall determine what equipment is considered loose equipment. The inspection shall consist of a review of drawings to identify that the design meets the specifications in Appendix D, table Corner and Edge Rounding Requirements. The verification shall be considered successful when the analysis and drawing inspection show that corners and edges are rounded to the specifications in Appendix D, table Corner and Edge Rounding Requirements.

Rationale: No further rationale is required.

4.3.2.4 Burrs

[HS4005V] Absence of burrs on surfaces shall be verified by inspection and test. The inspection shall determine the location of surfaces to which the crew or ground personnel are expected to be exposed during nominal operations. The test shall be a swatch test on all potential burrs. The verification shall be considered successful when the inspection and test show that no burrs are found on any exposed surfaces.

Rationale: Inspection and test of flight hardware are necessary because burr prevention is provided through quality workmanship, not design.

4.3.2.5 Sharp Items

[HS4006V] Controls for sharp items shall be verified by inspection and analysis. The inspection shall identify the sharp items to which the crew or ground personnel are expected to be exposed during nominal and maintenance operations. The analysis shall identify controls for the sharp items. The verification shall be considered successful when the inspection and analysis shows that sharp item controls are in place for the identified items.

Rationale: No further rationale is required.

4.3.2.6 Pinch Points

[HS4021V] Control for crew exposure to pinch points shall be verified by analysis. The analysis shall identify the location of potential pinch point locations in the vehicle. The

Revision: E	Document No: CxP 70024
Release Date: 11/19/10	Page: 229 of 503
Title: Constellation Program Human-Systems Integration Requirements	

analysis shall identify controls for those pinch points that are accessible by the crew. The verification shall be considered successful when pinch points are either inaccessible to the crew or have a control to prevent injury.

Rationale: No further rationale is required.

4.3.2.7 Interior Item Restraints

[HS4007V] Restraints for unstowed items shall be verified by analysis. The analysis shall identify all items that will be unstowed during any portion of the mission with consideration of the gravitational environment and identify the restraints provided by the system. The verification shall be considered successful when the analysis shows that each item that will be unstowed has a restraint mechanism if required.

Rationale: No further rationale is required.

4.3.2.8 Holes

[HS4023V] Round or slotted holes that are uncovered for equipment located inside habitable volumes shall be verified by inspection. The inspection shall be of engineering drawings. The verification shall be considered successful when the inspection shows that the minimum dimension of uncovered round or slotted holes in the habitable volume are smaller than 1.02 cm (0.4 in) or greater than 3.56 cm (1.4 in).

Rationale: No further rationale is required.

4.3.3 Electrical Hazards

4.3.3.1 Electrical Hazard Potential

[HS4008V] Prevention of crew exposure to currents greater than those in HS4008, table Electrical Hazard Potential and table Let-Go Current shall be verified by analysis and test. The analysis shall determine the locations where the crew may be exposed to electrical currents. The analysis shall identify controls at the locations where currents are greater than those provided in the tables. The test shall measure the electrical current at each of the locations as identified in the analysis. The verification shall be considered successful when the analysis and test show that the electrical current measured at each location to which the crew may be exposed is not greater than the current provided in the tables or that the electrical potentials controls are in place.

Rationale: No further rationale is required.

4.3.3.2 Chassis Leakage Current - Nonpatient Equipment

[HS4008BV] The nonpatient equipment chassis leakage current requirement shall be verified by test. The test shall consist of measuring the powered-up leakage current at the exposed chassis/enclosure surface of actual nonpatient flight hardware that could come into contact with crew or ground personnel. The verification shall be considered successful when the test indicates that the chassis leakage current is less than or equal to the associated limit in HS4008B, table Chassis Leakage Current – Nonpatient.

Revision: E	Document No: CxP 70024
Release Date: 11/19/10	Page: 230 of 503
Title: Constellation Program Human-Systems Integration Requirements	

Rationale: No further rationale is required.

4.3.3.3 Chassis Leakage Current - Patient Equipment

[HS4008CV] The patient-care equipment chassis leakage current requirement shall be verified by test. The test shall consist of measuring the powered-up leakage current at the exposed chassis/enclosure surface of actual patient-care flight hardware that could come into contact with crew, ground personnel, or patients. The verification shall be considered successful when the test indicates that the chassis leakage current is less than or equal to the associated limit in HS4008C, table Chassis Leakage Current - Patient.

Rationale: No further rationale is required.

4.3.4 Touch Temperature Limits

4.3.4.1 Hot Touch Temperature Limit

[HS4012V] Hot touch temperature limits shall be verified by test or analysis. A test, analysis or combination thereof shall determine the highest expected surface temperature of the object that may be contacted by the crew. For unlimited contact time, the verification shall be considered successful if the object's $(k\rho c)^{-1/2}$ (inverse square root of thermal inertia) is greater than 0.3 (which is the case for common materials such as Aluminum and less common materials such as pyrolitic graphite, gold and silver) and the object's temperature is lower than 45°C.

For contact time up to 10 seconds with any material, the verification shall be considered successful if the object's temperature is lower than 50°C.

If the object's $(k\rho c)^{-1/2}$ is less than 0.3 or the object's surface temperature is higher than 45°C for unlimited contact time, or higher than 50°C for contact time up to 10 seconds, an analysis shall be performed. The analysis shall use the following two sets of equations to calculate the maximum allowable object temperature or contact duration that would prevent the epidermis/dermis interface temperature from exceeding 44°C. The verification is considered successful if the object temperature (as determined from analysis or representative test) does not exceed T_{object}

For skin contact between 1-5 seconds:

$$T_{object} = YI [(k\rho c)_{object}^{-1/2} + 31.5] + 41$$

Where:

T_{object} = object temperature (°C)

YI = antilog [$YII (a_1) + \log YIII$]

$YII = 1.094 (t)^{-0.184}$

$YIII = 0.490 (t)^{-0.412}$

$(k\rho c)_{object}$ = thermal inertia of contact object material (cal²/cm⁴ °C² sec)

k = thermal conductivity, p = density, and c = specific heat

a₁ = epidermal thickness, in mm (average 0.25 mm)

t = time of exposure, in seconds (time of exposure is limited to between 1 and 5 seconds)

For skin contact < 1 second:

Use the equation above using 1 second for the exposure time. This is necessary to stay within the bounds of the data, and also allows for a margin of safety.

For skin contact > 5 seconds:

$$T_{object} = \frac{a}{\sqrt{(k\rho c)_p}_{object}} + b$$

where:

T_{object} = object temperature (°C)

(kρc)_{object} = object thermal inertia (cal²/cm⁴ °C² sec)

a, b = equation constants, found in the table below

TABLE 4.3.4.1-1 - HOT TOUCH TEMPERATURE CONSTANTS

time (s)	a	b
10	0.475	50.07
30	0.459	46.61
60	0.446	45.90
∞	0.422	44.87

Below is a table of $\frac{1}{\sqrt{(k\rho c)_{object}}}$ for some common materials:

TABLE 4.3.4.1-2 - INVERSE SQUARE ROOT OF THERMAL INERTIA FOR COMMON MATERIALS

<u>Material</u>	<u>Inverse Square Root of Thermal Inertia,</u> <u>(kρc)^{-1/2} (cm² °C sec^{1/2}/cal)</u>
Aluminum (6061T-6)	2.2

316 Stainless Steel	5.9
Glass	28.8
Teflon	57.5
Nylon Hook Velcro	586 (effective)

For contact times between those given in the table, perform a linear interpolation for time (a and b should not be interpolated). For example, for a duration of 20 seconds, calculate T_{object} for 10 and 30 seconds, equate the slope between 10 and 30 to the slope between 20 and 30 (or 10), and solve for the unknown variable, T_{object}

To calculate the allowable contact time for a given material at a particular temperature, build a table of allowable contact temperatures from 1 second to infinity and interpolate.

Note that at a value of $(k\rho c)^{-1/2} = 50 \text{ cm}^2 \text{ }^\circ\text{C s}^{1/2}/\text{cal}$, the curves for 5 seconds and 10 seconds intersect. Above this point, the curve for 30 seconds must be used to

interpolate all times between 5 and 30 seconds. For $(k\rho c)^{-1/2} < 50 \text{ cm}^2 \text{ }^\circ\text{C s}^{1/2}/\text{cal}$, the curve for 10 seconds may be used for interpolation.

The following is a graph for $\frac{1}{\sqrt{(k\rho c)_{\text{object}}}}$ between 0 and 100:

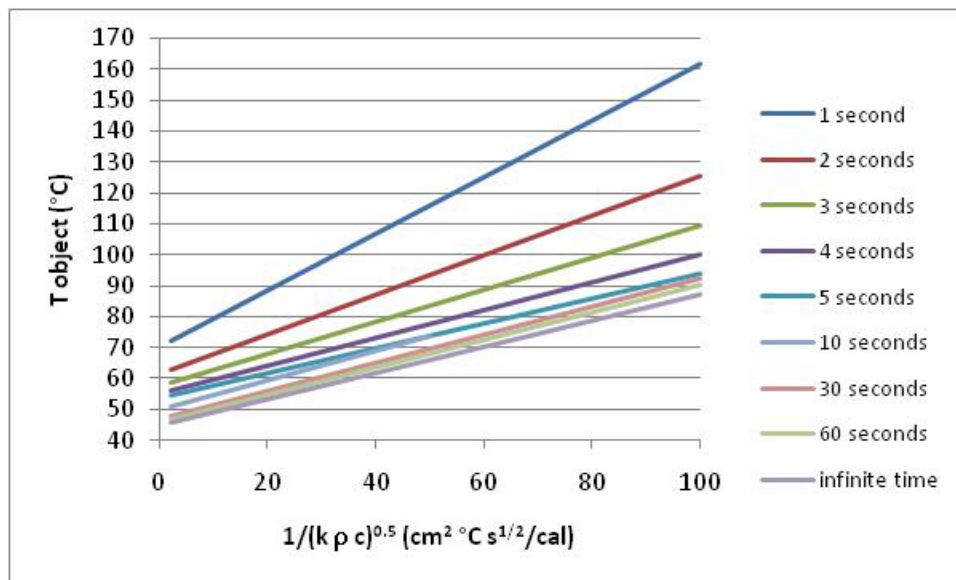


FIGURE 4.3.4.1-1 - ALLOWABLE HOT TOUCH TEMPERATURE DURATION

Revision: E	Document No: CxP 70024
Release Date: 11/19/10	Page: 233 of 503
Title: Constellation Program Human-Systems Integration Requirements	

Rationale: Stoll et al. (1979) developed a correlation to hot touch temperature data, which was valid from 1-5 seconds, and is represented by the equation. Beyond 5 seconds of contact, a different method is required. Hattan and Halfdanarson (1982) found that a semi-infinite model correlated well with Stoll's data using a contact conductance of 1,000 W/m²K. Solving the one-dimensional semi-infinite model with contact conductance for object temperature, assuming initial skin temperature of 32.5°C, epidermis thickness of 0.25 mm, skin inverse square root of thermal inertia of 27.96 cm² °C sec^{1/2} /cal, skin thermal conductivity of 0.54 W/m·K, and maximum dermis/epidermis temperature of 44°C, yields the equation and constants given in the verification for contact duration greater than 5 seconds. The object material is taken into account by using its thermal inertia in the equations. This method is only valid for thick, single materials. For aluminum, which has the lowest value of inverse thermal inertia for commonly flown materials, the methodology yields an allowable object temperature for infinite contact of 45.8 (deg) C. For 10 seconds for aluminum the object temperature limit is 50.3 (deg) C. Problems involving layers of materials (layups) may require the use of thermal models. Thermal models can also allow more exact calculation of allowable touch temperatures for thermally thin single material objects. The resulting allowable temperatures will be higher than those calculated using the above method.

Revision: E	Document No: CxP 70024
Release Date: 11/19/10	Page: 234 of 503
Title: Constellation Program Human-Systems Integration Requirements	

If a thermal model is used for verification, the method of Hattan and Halfdanarson (1982) is used. That is, it must meet the following conditions:

- One-dimensional semi-infinite skin model using
 - thermal conductivity of 0.54 W/m·K
 - thermal diffusivity of $1.3 \times 10^{-7} \text{ m}^2/\text{s}$ (combined with the thermal conductivity, this yields an inverse square root of thermal inertia of $27.96 \text{ cm}^2 \text{ }^\circ\text{C sec}^{1/2} / \text{cal}$)
 - density of 1200 kg/m^3 if required (modeling software may require the density and heat capacity of the skin as inputs – if this is the case, use this density, the thermal conductivity and the value of thermal diffusivity to calculate the specific heat), the exact value of density (and specific heat) do not affect the result
 - epidermal thickness of 0.25 mm
- Contact conductance of $1000 \text{ W/m}^2\text{K}$
- One-dimensional finite model of the object using appropriate material properties and thicknesses

The allowable contact time for a given object temperature is defined as the time when the epidermis/dermis interface reaches the pain threshold of 44°C .

4.3.4.2 Cold Touch Temperature Limit

[HS4012AV] Cold touch temperature limits shall be verified by test or analysis. The test or analysis shall determine the lowest expected surface temperature of the object that may be contacted by the crew. The verification shall be considered successful if the object temperature is higher than 10°C . If the object surface temperature is lower than 10°C , an analysis shall be performed. The analysis shall use the following equation to calculate the minimum object temperature that would limit skin temperature from going below 10°C . The verification is considered successful if the object temperature (as determined from analysis or representative test) is not below T_{object}

$$T_{\text{object}} = \frac{a}{(\sqrt{k\rho c_p})_{\text{object}}} + b$$

where:

T_{object} = object temperature($^\circ\text{C}$)

$(k\rho c_p)_{\text{object}}$ = object thermal inertia ($\text{cal}^2/\text{cm}^4 \text{ }^\circ\text{C}^2 \text{ sec}$)

a, b = equation constants, found in the table below

TABLE 4.3.4.2-1 - COLD TOUCH TEMPERATURE CONSTANTS

Contact time (s)	a	b
1	-0.880	-12.29
2	-0.832	-6.10
3	-0.802	-2.93
4	-0.781	-0.86
5	-0.765	0.66
10	-0.712	4.77
30	-0.620	9.50
60	-0.525	10.00
∞	-0.367	10.00

Below is a table of $\frac{1}{\sqrt{(k\rho c)_{object}}}$ for some common materials:

TABLE 4.3.4.2-2 - INVERSE SQUARE ROOT OF THERMAL INERTIA FOR COMMON MATERIALS

<u>Material</u>	<u>Inverse Square Root of Thermal Inertia, $(k\rho c)^{-1/2}$ (cm² °C sec^{1/2}/cal)</u>
Aluminum (6061T-6)	2.2
316 Stainless Steel	5.9
Glass	28.8
Teflon	57.5
Nylon Hook Velcro	586 (effective)

For contact times between those given in the table, perform a linear interpolation for time (a and b should not be interpolated). For example, for a duration of 20 seconds, calculate T_{object} for 10 and 30 seconds, equate the slope between 10 and 30 to the slope between 20 and 30 (or 10), and solve for the unknown variable, T_{object}

To calculate the allowable contact time for a given material at a particular temperature, build a table of allowable contact temperatures from 1 second to infinity and interpolate.

The following is a graph for $\frac{1}{\sqrt{(k\rho c)_{object}}}$ between 0 and 100:

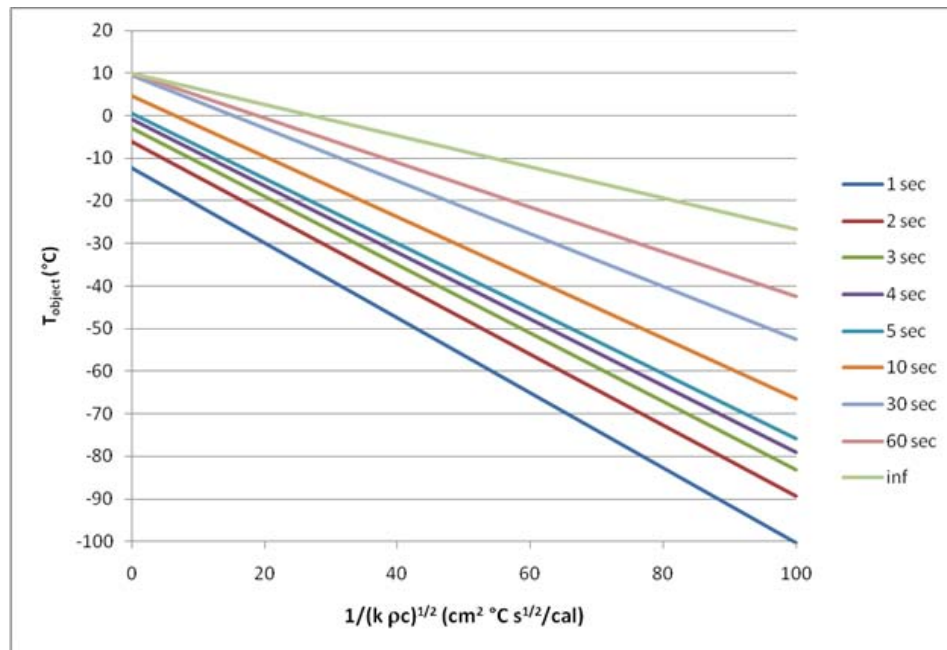


FIGURE 4.3.4.2-1 - ALLOWABLE COLD TOUCH TEMPERATURE DURATION

Rationale: Very little data exists in the literature for cold touch temperature. Geng et al., (2006) obtained data which was used to create ISO 13732-3: Ergonomics of the thermal environment – Methods for the assessment of human responses to contact with surfaces, Part 3: Cold Surfaces. However, there are only curves of time and allowable temperature for four specific materials: aluminum, stainless steel, Nylon, stone and wood. This data was used to develop a generalized cold touch temperature curve (and resulting equation and constants) for any material. The object's material is taken into account by using its thermal inertia in the equation. This method is only valid for thick, single materials. Problems involving layers of materials (layups) may require the use of thermal models.

If a thermal model is used for verification, it must meet the following conditions:

- *One-dimensional semi-infinite skin model using*
 - *thermal conductivity of 0.54 W/m·K*
 - *thermal diffusivity of $1.3 \times 10^{-7} \text{ m}^2/\text{s}$ (combined with the thermal conductivity, this yields an inverse square root of thermal inertia of $27.96 \text{ cm}^2 \text{ }^\circ\text{C sec}^{1/2} / \text{cal}$)*
 - *density of 1200 kg/m^3 if required (modeling software may require the density and heat capacity of the skin as inputs – if this is the case, use this density, the thermal conductivity and the value of thermal diffusivity)*

Revision: E	Document No: CxP 70024
Release Date: 11/19/10	Page: 237 of 503
Title: Constellation Program Human-Systems Integration Requirements	

to calculate the specific heat), the exact value of density (and specific heat) do not affect the result.

- *Infinite contact conductance - to allow for the effects of condensation on the object surface.*
- *One-dimensional finite model of the object using appropriate material properties and thicknesses.*

The allowable contact time for a given object temperature is defined as the time when the skin surface reaches the pain threshold of 10°C.

4.3.5 Fire Suppression Portability

4.3.5.1 Fire Suppression Portability

[HS4019V] The portable fire suppression system shall be verified by inspection. The inspection shall include a review of the system design to ensure that a portable fire suppression system is included in the system design. The verification shall be considered successful when the inspection shows that the design includes portable fire suppression equipment.

Rationale: No further rationale is required.

4.4 ARCHITECTURE

4.4.1 Configuration

4.4.1.1 Layout Interference

[HS5001V] Not Applicable

4.4.1.2 Layout Sequential Operations

[HS5002V] Not Applicable

4.4.1.3 Workstation Visual Demarcations

[HS5042V] Demarcations for adjacent workstations shall be verified by inspection. The inspection shall consist of identifying adjacent workstations and identifying the demarcations between adjacent workstations. The verification shall be considered successful when the inspection shows that visual demarcations are identified for all adjacent workstations.

Rationale: No further rationale is required.

4.4.1.4 Workstation Orientation

[HS5003V] Workstation alignment shall be verified by analysis and inspection. The analysis shall consist of determining all user-interface elements within each workstation, the expected crew head position at each workstation, and identifying the centerline for

Revision: E	Document No: CxP 70024
Release Date: 11/19/10	Page: 238 of 503
Title: Constellation Program Human-Systems Integration Requirements	

each user interface element. The inspection shall consist of measuring the orientation angle of each user-interface element as the angle between the crew head position local vertical centerline and the user-interface element local vertical centerline. The verification shall be considered successful when analysis and inspection show that all orientation angles for all user-interface elements within each workstation are measured to be 0 degrees.

Rationale: No further rationale is required.

4.4.1.5 Location Coding

[HS7009V] Use of a standard location coding system providing unique identifiers shall be verified by inspection. The inspection shall address all predefined locations within the vehicle. The inspection shall be of inclusion of a standard location coding system within the vehicle Label Plan. The verification shall be considered successful when the inspection shows that all predefined locations follow a standard location coding system in accordance with CxP 70152, Constellation Program Crew Interface Labeling Standard.

Rationale: No further rationale is required.

4.4.2 Translation Paths

4.4.2.1 Ingress and Egress Translation Paths

[HS5004V] Translation paths shall be verified by analysis and demonstration. Analysis shall include identifying suited operation scenarios for crew ingress and egress (nominal and off-nominal) from one vehicle or transfer between two, including the likely pressurization state of suits. Analysis shall consist of using high-fidelity computer graphic models. The models shall include the vehicles, suited crewmembers, and suited crewmembers' movement through the translation paths. The demonstration shall occur in a high-fidelity mockup in 1 g in the flight configuration with integrated GFE, stowage, vehicle installations, and closeouts installed. The demonstration shall consist of suited subjects performing ingress and egress (nominal and off-nominal) operation scenarios. The verification shall be considered successful when the analysis and demonstration show that suited ingress and egress (nominal and off-nominal) operations can be performed without being hampered by protrusions and snag points.

Rationale: No further rationale is required.

4.4.2.2 Internal Translation Paths

[HS5005V] Translation paths shall be verified by analysis and demonstration. Analysis shall consist of performing unsuited operation scenarios using high-fidelity computer graphic models. The models shall include the vehicle, unsuited crewmembers, and unsuited crewmembers' movement through the translation paths. The demonstration shall occur in a high-fidelity mockup in 1 g in the flight configuration with integrated GFE, stowage, vehicle installations, and closeouts installed. The demonstration shall consist of unsuited subjects performing operation scenarios. The verification shall be

Revision: E	Document No: CxP 70024
Release Date: 11/19/10	Page: 239 of 503
Title: Constellation Program Human-Systems Integration Requirements	

considered successful when the analysis and demonstration show that unsuited operations can be performed.

Rationale: No further rationale is required.

4.4.2.3 Crew Egress Translation Path - Ground

[HS5010V] The translation path for the assisted ground egress of an incapacitated suited crewmember shall be verified by analysis and demonstration. The analysis shall consist of volumetric modeling of the ground translation path and human models of the incapacitated crewmember and the assisting crewmembers and/or ground personnel. The demonstration shall consist of a crewmember serving the role of the incapacitated crewmember and the assisting crewmembers and/or ground personnel. The verification shall be considered successful when the analysis and demonstration prove that the ground translation path provides sufficient clearance for the assisted ingress and egress of an incapacitated suited crewmember.

Rationale: No further rationale is required.

4.4.2.4 Crew Ingress/Egress Translation Path in Space

[HS5053V] The translation path for the assisted in-space ingress and egress of an incapacitated pressurized-suited crewmember shall be verified by analysis and demonstration. The analysis shall consist of volumetric modeling of the in-space translation path and human models of the incapacitated crewmember and the assisting crewmembers. The demonstration shall consist of a high-fidelity mockup or flight vehicle and use of a simulated pressurized-suited crewmember with weight representative of the applicable gravity environment and the assisting crewmembers. The verification shall be considered successful when the analysis and demonstration prove that the in-space translation path provides sufficient clearance for the assisted ingress and egress of an incapacitated crewmember.

Rationale: No further rationale is required.

4.4.3 Restraints and Mobility Aids

4.4.3.1 Standard Restraints and Mobility Aids

[HS5006V] Not Applicable.

4.4.3.2 IVA Mobility Aids

[HS5007V] The provision of mobility aid shall be verified by inspection. Inspection shall consist of a review of engineering drawings and planned IVA operations. The verification shall be considered successful when the inspection shows that mobility aids are in locations to support IVA operations.

Rationale: No further rationale is required.

Revision: E	Document No: CxP 70024
Release Date: 11/19/10	Page: 240 of 503
Title: Constellation Program Human-Systems Integration Requirements	

4.4.3.3 Workstation Restraints

[HS5008V] Restraint placement for two-handed operations shall be verified by inspection. The inspection shall consist of a review of engineering drawings and identified locations for two-handed operations. The verification shall be considered successful when the inspection shows that restraint placement allows two-handed operations in 0 g.

Rationale: No further rationale is required.

4.4.3.4 Ingress and Egress Mobility Aids

[HS5009V] Mobility aids for ingress and egress (nominal and off-nominal) shall be verified by inspection. The inspection shall consist of a review of engineering drawings and ingress and egress translation paths. The verification shall be considered successful when the inspection shows that restraint placement allows for ingress and egress (nominal and off-nominal).

Rationale: No further rationale is required.

4.4.3.5 Commonly Distinguishable Handrails

[HS5052V] Not applicable.

4.4.3.6 Egress Handrails

[HS5054V] Not Applicable.

4.4.4 Hatches

4.4.4.1 Hatch Operation

4.4.4.1.1 Nominal Hatch Operation

4.4.4.1.1.1 Hatches Operable Inside and Outside

[HS5013V] Hatch operability from both sides shall be verified by demonstration. The demonstration shall occur in a qualification vehicle or a high-fidelity mockup, and the vehicle or mockup shall be in the flight configuration with integrated GFE, stowage, vehicle installations, and closeouts installed. The demonstration shall consist of one suited subject performing the following four tasks: unlatching and fully opening each hatch from the inside, unlatching and fully opening each hatch from the outside, closing and latching each fully-opened hatch from the inside, and closing and latching each fully-opened hatch from the outside. The verification shall be considered successful when the demonstration shows that a suited subject can complete the four tasks.

Rationale: No further rationale is required.

4.4.4.1.1.2 Hatches Operable in 60 Seconds

[HS5043V] Hatch operability in 60 seconds shall be verified by demonstration. The demonstration shall occur in a qualification vehicle or a high-fidelity mockup, and the

Revision: E	Document No: CxP 70024
Release Date: 11/19/10	Page: 241 of 503
Title: Constellation Program Human-Systems Integration Requirements	

vehicle or mockup shall be in the flight configuration with integrated GFE, stowage, vehicle installations, and closeouts installed. The demonstration shall demonstrate 0-g operability by performing the tasks in 1 g and applying a 0-g factor to the task completion time. The demonstration shall consist of one suited subject performing the following four tasks: unlatching and fully opening each hatch from the inside, unlatching and fully opening each hatch from the outside, closing and latching each fully-opened hatch from the inside, and closing and latching each fully-opened hatch from the outside. The demonstration task completion time shall be measured in seconds. The verification shall be considered successful when the demonstration shows that the completion time is 60 seconds or less per task.

Rationale: No further rationale is required.

4.4.4.1.1.3 Hatches Operable Without Tools

[HS5044V] Hatch operability without the use of tools shall be verified by demonstration. The demonstration shall occur in a qualification vehicle or a high-fidelity mockup, and the vehicle or mockup shall be in the flight configuration with integrated GFE, stowage, vehicle installations, and closeouts installed. The demonstration shall consist of one suited subject performing the following four tasks: unlatching and fully opening each hatch from the inside, unlatching and fully opening each hatch from the outside, closing and latching each fully-opened hatch from the inside, and closing and latching each fully-opened hatch from the outside. The demonstration task completion time shall be measured in seconds. The verification shall be considered successful when the demonstration shows that the hatch is operable without the use of tools.

Rationale: No further rationale is required.

4.4.4.1.1.4 Hatches Operable by Suited Crewmembers

[HS5045V] Hatch operability by a suited crewmember shall be verified by analysis and demonstration. Analysis shall include identifying suited operation scenarios for crew ingress and egress (nominal and off-nominal) from one vehicle or transfer between two, including the likely pressurization state of suits. Analysis shall also identify which hatch operations are necessary for a suited crewmember. The demonstration shall occur in a qualification vehicle or a high-fidelity mockup, and the vehicle or mockup shall be in the flight configuration with integrated GFE, stowage, vehicle installations, and closeouts installed. The demonstration shall consist of one suited subject performing the following four tasks that are identified to be necessary for a suited crewmember: unlatching and fully opening each hatch from the inside, unlatching and fully opening each hatch from the outside, closing and latching each fully-opened hatch from the inside, and closing and latching each fully-opened hatch from the outside. The verification shall be considered successful when the analysis and demonstration show that a suited crewmember has successfully completed all tasks.

Rationale: No further rationale is required.

Revision: E	Document No: CxP 70024
Release Date: 11/19/10	Page: 242 of 503
Title: Constellation Program Human-Systems Integration Requirements	

4.4.4.1.1.5 Unlatching Hatches

[HS5046V] Hatch unlatching shall be verified by demonstration. The demonstration shall occur in a qualification vehicle or a high-fidelity mockup, and the vehicle or mockup shall be in the flight configuration with integrated GFE, stowage, vehicle installations, and closeouts installed. The demonstration shall consist of one suited subject opening the hatch from a closed and latched position. The verification shall be considered successful when the demonstration shows that unlatching requires two distinct and sequential operations.

Rationale: No further rationale is required.

4.4.4.1.2 Pressure Equalization of Hatches

4.4.4.1.2.1 Hatch Manual Pressure Equalization Inside and Outside

[HS5014V] Manual pressure equalization on each side of the hatch by a crewmember shall be verified by demonstration. The demonstration shall occur in the vehicle or a high-fidelity mockup. The demonstration shall consist of performing a manual pressure equalization procedure on both sides of each hatch under the range of expected internal/external pressure levels. The verification shall be considered successful when the demonstration shows that the procedure can be performed.

Rationale: No further rationale is required.

4.4.4.1.2.2 Hatch Manual Pressure Equalization by Suited Crewmembers

[HS5048V] Manual pressure equalization on each side of the hatch shall be verified by demonstration. The demonstration shall occur in the vehicle or a high-fidelity mockup. The demonstration shall consist of performing a manual pressure equalization procedure on both sides of each hatch under the range of expected internal/external pressure levels. The verification shall be considered successful when the demonstration shows that a pressurized suited crewmember can complete the procedure.

Rationale: No further rationale is required.

4.4.4.2 Hatch Indications

4.4.4.2.1 Hatch Status Indications

4.4.4.2.1.1 Hatch Latch Position

[HS5049V] Latch position status shall be verified by demonstration. The demonstration shall occur in the vehicle or a high-fidelity mockup. The demonstration shall consist of the following tasks completed on the inside and outside of each hatch: open the latch and identify that the latch position status indicates that the latch is open; close the latch and identify that the latch position status indicates that the latch is closed. Verification of latch position status shall be considered successful if the demonstration shows that all latch positions are accurately displayed on each side of each hatch.

Revision: E	Document No: CxP 70024
Release Date: 11/19/10	Page: 243 of 503
Title: Constellation Program Human-Systems Integration Requirements	

Rationale: No further rationale is required.

4.4.4.2.1.2 Hatch Closure Indication

[HS5016V] Hatch closure status shall be verified by demonstration. The demonstration shall occur in a qualification vehicle or a high-fidelity mockup. The demonstration shall consist of the following tasks: opening the hatch and identifying that the hatch closure status indicates that the hatch is open and closing the hatch and identifying that the hatch closure status indicates that the hatch is closed. The verification shall be considered successful when the demonstration shows that the hatch closure status is displayed from each side of each hatch.

Rationale: No further rationale is required.

4.4.4.2.1.3 Hatch Pressure Difference Measurement

[HS5050V] Pressure difference measurement shall be verified by demonstration. The demonstration shall occur in the vehicle or high-fidelity mockup. The demonstration shall consist of one suited subject performing the pressure difference measurement on both sides of each hatch under the range of expected internal/external pressure levels. The verification shall be considered successful when the demonstration shows that all pressure differences are measured on each side of the vehicle.

Rationale: No further rationale is required.

4.4.4.2.1.4 Hatch Visual Observation

[HS5017V] The provision of a window that provides for direct visual, non-electronic observation of the opposite side of a hatch shall be verified by inspection of the engineering drawings and the flight article. The adequacy of the field of view provided by the window shall be verified by analysis and demonstration. The analysis shall provide a graphical depiction of the field of view with respect to the system in which it is installed. The demonstration shall include an observer selected by NASA who has at least the visual acuity of a mission specialist astronaut. The observer shall look through the window in the flight article or a high fidelity mockup thereof to determine the adequacy of the field of view provided. The verification shall be considered successful when the inspection shows that there is a window present in the flight article for this purpose and the analysis and demonstration show that the direct visual, non-electronic field of view provided by the window is adequate to determine the state of the environment on the opposite side of the hatch in both viewing directions.

Rationale: No further rationale is required.

4.4.5 Windows

4.4.5.1 Window Optical Properties

[HS5019V] System window optical performance characteristics and tasking consistency shall be verified by analysis, inspection, and test. The analysis shall include a task

Revision: E	Document No: CxP 70024
Release Date: 11/19/10	Page: 244 of 503
Title: Constellation Program Human-Systems Integration Requirements	

analysis to identify the windows of the crewed system and the tasks to be performed at each window. The inspection shall assess the optical properties of the windows and consist of an inspection of the engineering drawings and data packs for each pane and the finished window stack. The test shall consist of optical tests and visual uniformity tests. Visual uniformity testing shall be done on the finished windows, otherwise any other testing may be done on witness samples. The visual uniformity tests shall utilize a test subject with a corrected or uncorrected visual acuity of 20/20. The visual uniformity test report shall be provided to NASA and shall include wavefront properties and results of optical uniformity testing. The verification shall be considered successful when the inspection and the optical tests show that the optical properties of each pane and the finished window stack meet or exceed the properties specified in JSC 63307, Requirements for Optical Properties for Windows Used in Crewed Spacecraft, and for Orion in CxP 72407, Orion Crew Exploration Vehicle Window Optical Properties Requirements, consistent with tasking identified in the analysis, and the visual uniformity tests show that there are no readily identifiable defects in any of the individual panes and in the finished window stack.

Rationale: Visual inspection and test prior to installation are necessary to identify any imperfections in optical quality or performance, and to determine the operational impacts of those visual imperfections, if any, given their type, severity, and location. The methodology and procedure for test and verification of optical properties are contained in the following reference document: ATR-2000(2112)-1, International Space Station Destiny Module Science Window Optical Properties and Wavefront Verification Test Results, Aerospace Corp., March 2000; the methodology and procedure for visual uniformity testing are contained in the following reference document: ATR-2003(7828)-1, International Space Station Cupola Scratch Pane Window Optical Test Results, Aerospace Corp., January 17, 2003. A witness sample is a portion of that material that is processed at the same time and under the same conditions as the end item product. NASA participation in test plan development and execution at the vendor's facility may be necessary and are permitted as part of NASA's technical oversight role.

4.4.5.2 Window Viewing for Piloting Tasks

[HS5021V] The provision of a minimum of two piloting windows shall be verified by inspection of the engineering drawings and the flight article. The functionality of system piloting windows shall be verified by analysis and demonstration. The analysis shall use high-fidelity computer graphic models. The demonstration shall use simulators and mockups that employ the computer graphic models and shall include piloting crewmembers at piloting workstations who shall evaluate the adequacy of the positioning of and views provided by the windows for the various piloting tasks. The models shall include the piloted vehicle and all external objects required for piloting tasks such as the earth, moon, stars, and other vehicles. The analysis shall provide a graphical depiction of the field-of-view through the piloting windows. The verification shall be considered successful when the inspection verifies the presence of a minimum

Revision: E	Document No: CxP 70024
Release Date: 11/19/10	Page: 245 of 503
Title: Constellation Program Human-Systems Integration Requirements	

of two piloting windows and the analysis and demonstration show that the fields-of-view through the piloting windows are adequate to support all NASA-approved piloting tasks.

Rationale: No further rationale is required.

4.4.5.3 Window for External Viewing Observation

[HS5022V] The provision of an external observation window shall be verified by inspection of the engineering drawings and data packs for the lead flight article, followed by inspection of engineering drawings and data packs only for subsequent articles. The functionality of the external observation window shall be verified by analysis and demonstration. The verification shall be considered successful when the inspection shows that a window has been provided for external observation and that the analysis and demonstration show that the system window provides the optical characteristics and field-of-view appropriate to its tasking per JSC 63307, Requirements for Optical Properties for Windows Used in Crewed Spacecraft.

Rationale: No further rationale is required.

4.4.5.4 Window for Motion Imagery and Photography

[HS5055V] The optical performance of the window that supports motion imagery and photography with lens apertures up to 100 mm in diameter shall be verified by analysis and test. The analyses and tests shall show that the optical properties of the window and specifically the peak to valley transmitted wavefront errors are compliant with appropriate categories in JSC 63307, Requirements for Optical Properties for Windows Used in Crewed Spacecraft, and for Orion in CxP 72407, Orion Crew Exploration Vehicle Window Optical Properties Requirements. The verification shall be considered successful when the analysis and test shows that the optical performance of the window that supports motion imagery and photography with lens apertures up to 100 mm in diameter.

Rationale: No further rationale is required.

4.4.5.5 Window Cover, Shade, and Filter Removal or Replacement without Tools

[HS5051V] The ability to remove and replace system window covers, shades, and filters without the use of tools by one crewmember shall be verified by demonstration. The demonstration shall occur in the flight article or a high-fidelity mockup. The demonstration shall consist of removing and then replacing each window cover, shade, and filter without the use of tools by a crewmember test subject who shall be selected by NASA. The verification shall be considered successful when the demonstration shows that each cover, shade, and filter is removable and replaceable without the use of tools by a single test subject.

Rationale: No further rationale is required.

Revision: E	Document No: CxP 70024
Release Date: 11/19/10	Page: 246 of 503
Title: Constellation Program Human-Systems Integration Requirements	

4.4.5.6 Window Cover, Shade, and Filter Removal or Replacement in 10 Seconds

[HS5027V] Window cover, shade, and filter removal or replacement in less than 10 seconds shall be verified by demonstration. The demonstration shall occur in the vehicle or high-fidelity mockup. The demonstration shall consist of removing and then replacing each window cover, shade, and filter without the use of tools by a crewmember test subject who shall be selected by NASA. The verification shall be considered successful when the demonstration shows that each cover, shade, and filter is removable in less than 10 seconds and replaceable in less than 10 seconds.

Rationale: No further rationale is required.

4.4.5.7 Obstruction

[HS5030V] Not Applicable.

4.4.5.8 Window and Internal Darkening

[HS5031V] The provision of system window shades or shutters that prevent external light from entering the crew cabin shall be verified by inspection. The efficacy of system window shades and shutters shall be verified by test. The inspection shall confirm that a system window shade or shutter has been provided for each window. The test shall fit all shades into place and/or operate or move shutters into place over the window and then the internal illumination near each window on the interior of the system shall be measured. The test shall utilize an external light source whose illumination on the exterior of the windows shall be equivalent to orbital sunlight illuminance at orbital noon with the largest of the windows directly facing the illumination source while the majority of the rest of the system windows also face the illumination source to the maximum extent possible. There shall be no internal illumination sources present and the interior of the vehicle shall be completely darkened while the illumination near each window on the interior is measured. The test measurement shall be at locations 0.5 m +/- 0.05 m (~0.6 ft) along the inboard normal at the point of maximum observable illumination. The verification shall be considered successful when the inspection shows that the shade or shutter has been provided for each window and the test shows that the shades and shutters reduce the light level within the habitable volume to less than 2 lux.

Rationale: No further rationale is required.

4.4.5.9 Window Proximity Finishes

[HS5032V] The presence of a lusterless finish or coating on all system window frames and supporting structure shall be verified by inspection. The efficacy of the finishes and coatings shall be verified by inspection of the product technical specification sheets of each finish and coating by lot. The placement of the coating shall be verified by inspection of the window structure and finish or coating design and drawings to determine the geometry of the window and placement of lusterless finish or coating. The verification shall be considered successful when the inspection shows the required

Revision: E	Document No: CxP 70024
Release Date: 11/19/10	Page: 247 of 503
Title: Constellation Program Human-Systems Integration Requirements	

finish or coating has been applied directions, both internally and externally and the test shows that the applied finishes or coatings have a reflectance of less than 10% over a wavelength range of 400–800 nm.

Rationale: No further rationale is required.

4.4.6 Lighting

4.4.6.1 Interior Lighting

4.4.6.1.1 Lighting Level by Task

[HS5035V] The lighting level for tasks shall be verified by analysis and test. The analysis shall identify the system surfaces to be illuminated by interior lights and shall consider architectural constraints, task requirements, and the operational configurations in which they will be used, including the positions of operators and deployed hardware. The test shall occur in a flight-like vehicle or high-fidelity mockup and will consist of measurement of illumination at the surfaces with an illuminance meter normal to the workstation work/reading plane with lights, workstations, deployed hardware, and operators in their design configurations. The verification shall be considered successful when the analysis and test show that the surface illumination meets the values in HS5035, table Lighting Level by Task, and that most surfaces in the vehicle common areas can be illuminated by general lighting to 350 lux, including items in transit.

Rationale: Testing in the flight-like vehicle or high-fidelity mockup with representative tasks and hardware is necessary to validate the task analysis to identify lighting requirements per location, to determine potential interference and shadowing due to deployed hardware and operators, and to ensure that the lighting configuration is responsive to dynamic crew tasks and vehicle reconfiguration. Because not all tasks will be defined with high fidelity prior to vehicle design, general illumination to 350 lux must be accommodated at most vehicle locations to ensure task performance and flexibility. Portable lights may be used to supplement general and task lighting for off-nominal activities such as behind-the-panel maintenance but cannot be considered in vehicle lighting configurations for verification of tasks in the nominal configurations of the vehicle.

4.4.6.1.2 Interior Light Adjustability

[HS5034BV] The adjustability of the interior lighting shall be verified by test. The test shall be performed in a qualification vehicle or high-fidelity mockup. The test shall consist of measurements performed as specified in the individual vehicle requirements. These requirements explicitly state the location and orientation of the measurement as well as the minimum and maximum illumination levels. The verification shall be considered successful when the test shows that the interior lighting can be adjusted to its minimum and maximum output levels.

Rationale: No further rationale is required.

Revision: E	Document No: CxP 70024
Release Date: 11/19/10	Page: 248 of 503
Title: Constellation Program Human-Systems Integration Requirements	

4.4.6.2 Lighting Controls

4.4.6.2.1 General Light Control

[HS5039V] System interior lighting controllability shall be verified by analysis and demonstration. The analysis shall consist of identifying the interior lights, their associated controls, and likely configuration of the vehicle during the lights' intended use. The demonstration shall consist of affecting the lighting controls in the intended vehicle configuration, and observing the change in lighting condition. The verification shall be considered successful when the analysis and demonstration show that all vehicle interior lights can be controlled from the volume in which they are located and can be observed from the control location.

Rationale: No further rationale is required.

4.4.6.2.2 Workstation Light Control

[HS5040V] Workstation lighting control shall be verified by demonstration. The demonstration shall occur in a qualification vehicle or high-fidelity mockup. The demonstration shall consist of a subject restrained at a workstation powering on and off the workstation lighting. The verification shall be considered successful when the demonstration shows that the subject is able to control the task lighting from the restrained position.

Rationale: No further rationale is required.

4.4.6.2.3 Workstation Light Position Adjustment

[HS5041V] Task lighting adjustability shall be verified by demonstration. The demonstration shall occur in a qualification vehicle or high-fidelity mockup. The demonstration shall consist of a subject restrained at a workstation, adjusting the position of the lighting, where applicable. The verification shall be considered successful when the demonstration shows that the subject is able to adjust the task lighting from the restrained position.

Rationale: No further rationale is required.

4.4.6.2.4 Lighting ON/OFF Control

[HS5056V] Operation of the On/Off control to prevent and restore light emission by the lights shall be verified by demonstration. The demonstration shall consist of turning the On/Off control to the Off condition and subsequent observation of the controlled light by an observer who has been dark adapted for at least 20 minutes, followed by returning the control to the On condition. The demonstration shall be deemed successful if the Off condition of the control is evident by touch or sight, the adapted observer detects no visible light emanating from the light source with the control in the Off condition, and selection of the On condition of the control reactivates the light.

Rationale: No further rationale is required.

Revision: E	Document No: CxP 70024
Release Date: 11/19/10	Page: 249 of 503
Title: Constellation Program Human-Systems Integration Requirements	

4.5 CREW FUNCTIONS

4.5.1 Food Preparation

4.5.1.1 Cross-Contamination

4.5.1.1.1 Cross-Contamination Prevention

[HS6001V] Not Applicable

4.5.1.1.2 Cross-Contamination Separation

[HS6002V] Not Applicable

4.5.1.2 Preparation

4.5.1.2.1 Heating

[HS6003V] The hot food and drink temperature shall be verified by test. The test shall use a flight-like unit. The test shall measure the temperature of the food and drink after heating. The verification shall be considered successful when the test shows that the system can heat food and drink to temperatures between 68 °C (155 °F) and 79 °C (175 °F).

Rationale: No further rationale is required.

4.5.1.2.2 Rehydration

[HS6004V] Rehydration of food and drinks shall be verified by demonstration. The demonstration shall consist of transferring potable water to the drink and food packages. The verification shall be considered successful when the demonstration shows that appropriate amounts of water can be transferred into food and drink packages without depending on gravity.

Rationale: No further rationale is required.

4.5.1.2.3 In-Flight Food Preparation Time

[HS6005V] Not Applicable

4.5.1.2.4 Lunar Surface Food Preparation Time

[HS6102V] The time required to prepare a meal for four crewmembers on the lunar surface shall be verified by test and analysis. The test shall be performed in a high-fidelity mockup. The test shall record the time required for meal preparation for four crewmembers based on mission-specific food system requirements. The analysis shall take the time recorded from the test and multiply it by a program defined reduced gravity factor. The verification shall be considered successful when the test and analysis shows that four crew meals can be prepared within 30 minutes on the lunar surface.

Revision: E	Document No: CxP 70024
Release Date: 11/19/10	Page: 250 of 503
Title: Constellation Program Human-Systems Integration Requirements	

Rationale: The verification will need to show that all food preparation tasks can be completed within an expected timeline. The analysis portion of this verification intends to account for the additional time typically required to complete tasks in a reduced gravity environment. The program will define the reduced gravity factor for each mission profile.

4.5.1.3 Food System

4.5.1.3.1 Food System

[HS6059V] The nutritional content of the food system shall be verified by analysis. The analysis shall determine nutrient content of each food item. The analysis shall determine the nutrient content for a menu. The verification shall be considered successful when analysis shows that the menu meets the nutritional requirements in HS6059, table Nutrition Composition Breakdown.

Rationale: No further rationale is required.

4.5.1.3.2 Metabolic Intake

[HS6060V] The metabolic intake provisioning shall be verified by analysis. The analysis shall determine energy content of each food item. In addition, further analysis shall determine the energy content for a menu. The verification shall be considered successful when the analysis shows that the menu meets 12,707 kJ (3,035 kilocalories) per day.

Rationale: No further rationale is required.

4.5.1.3.3 Metabolic Intake for EVA

[HS6062V] The additional nutrition for EVA suited operations shall be verified by analysis. The analysis shall determine the nutritional content of each food item available for consumption during EVA operations. The verification shall be considered successful when the analysis shows that the food items meet the additional 837 kJ (200 kilocalories) per hour above nominal metabolic requirements for suited operations.

Rationale: No further rationale is required.

4.5.2 Personal Hygiene

4.5.2.1 Personal Hygiene Items

[HS6105V] The provision of personal hygiene items for each crewmember shall be verified by inspection. The inspection shall be of the engineering drawings. The inspection shall be considered successful when it is shown that personal hygiene items are present in the engineering drawings.

Rationale: No further rationale is required.

Revision: E	Document No: CxP 70024
Release Date: 11/19/10	Page: 251 of 503
Title: Constellation Program Human-Systems Integration Requirements	

4.5.2.2 Personal Hygiene Privacy

[HS6009V] Visual privacy during personal hygiene shall be verified by demonstration and analysis. The demonstration shall use a volumetrically accurate high-fidelity mockup of the vehicle. The demonstration shall consist of subjects performing personal hygiene activities. The analysis shall extrapolate to the minimum and maximum critical dimensions. The verification shall be considered successful when the demonstration and analysis show that the largest male and smallest female crewmembers can complete all personal hygiene related activities with visual privacy.

Rationale: No further rationale is required.

4.5.2.3 Personal Hygiene Stowage

[HS6010V] Not Applicable

4.5.2.4 Personal Hygiene Trash

[HS6012V] Not Applicable

4.5.2.5 Full Body Visual Privacy

[HS6027V] Visual privacy during waste management shall be verified by demonstration. The demonstration shall consist of a crewmember performing all body waste management activities using a high-fidelity mockup. The verification shall be considered successful when the demonstration shows that a crewmember can complete all body waste management related activities with full body visual privacy.

Rationale: No further rationale is required.

4.5.2.6 Body Self-Inspection and Cleaning

[HS6028] Not Applicable

4.5.3 Body Waste Management

4.5.3.0.1 Vomitus Collection and Containment

[HS6013V] Vomitus collection and containment shall be verified by demonstration and analysis. The demonstration shall be performed with flight-like hardware to show containment independent of gravity. The demonstration shall consist of release into the collection system. The analysis shall determine the volume of the collection system. The verification shall be considered successful when the demonstration and analysis show that the collection system can collect and contain 0.5 L per event for the number of events identified in HS6013, table Vomitus Collection and Containment per crewmember for the duration of the mission.

Rationale: No further rationale is required.

Revision: E	Document No: CxP 70024
Release Date: 11/19/10	Page: 252 of 503
Title: Constellation Program Human-Systems Integration Requirements	

4.5.3.2 Feces

4.5.3.2.1 Fecal Wipes

[HS6016V] The consumable wipe materials collection and containment shall be verified by analysis. The analysis shall determine the volume needed for accommodation of consumable wipe materials and shall identify controls for the escape of contents. The verification shall be considered successful when the analysis shows that the volume needed for collection of consumable wipe materials is provided and escape of fecal contents is contained.

Rationale: No further rationale is required.

4.5.3.2.2 Feces per Day

[HS6017V] The collection and containment of fecal matter shall be verified by demonstration and analysis. The demonstration shall be performed with flight-like hardware to show containment independent of gravity. The demonstration shall consist of a release into the collection system, followed by a repeated release into the collection system. The analysis shall determine the volume of the collection system. The verification shall be considered successful when the analysis shows that 150 g and 150 mL of fecal matter per crewmember per defecation at an average of two defecations per day are contained.

Rationale: No further rationale is required.

4.5.3.2.3 Feces per Event

[HS6020CV] The collection and containment of fecal matter shall be verified by demonstration and inspection. The inspection shall determine the volume of the collection system. The demonstration shall occur in an analogous gravity environment with flight-like hardware. The demonstration shall consist of a release into the collection system. The verification shall be considered successful when the inspection and demonstration show that the collection system can hold 500 g and 500 mL of fecal matter per crewmember, release can be collected, and release is contained.

Rationale: No further rationale is required.

4.5.3.2.4 Diarrhea per Event

[HS6020V] The per event collection and containment of diarrhea discharge shall be verified by demonstration and analysis. The analysis shall determine the volume of the collection system. The demonstration shall be performed with flight-like hardware to show containment independent of gravity. The demonstration shall consist of a release into the collection system. The verification shall be considered successful when the analysis and demonstration show that the collection system can hold 1.5 L of diarrheal discharge in a single event, each release can be collected with no spillage or leakage, and each release is contained.

Revision: E	Document No: CxP 70024
Release Date: 11/19/10	Page: 253 of 503
Title: Constellation Program Human-Systems Integration Requirements	

Rationale: No further rationale is required.

4.5.3.2.5 Diarrheal Events per Crewmember

[HS6020DV] The collection and containment of diarrheal events for a mission shall be verified by demonstration and analysis. The analysis shall determine the volume of the collection system. The demonstration shall be performed with flight-like hardware to show containment independent of gravity. The demonstration shall consist of repeated releases into the collection system. The verification shall be considered successful when the analysis and demonstration show that the collection system for a mission can hold the specified number of events per crewmember as indicated in HS6020D, table Diarrhea Collection and Containment.

Rationale: No further rationale is required.

4.5.3.3 Urine

4.5.3.3.1 Urine Collection

[HS6021V] The collection of urine shall be verified by demonstration. The demonstration shall be performed with flight-like hardware. The demonstration shall consist of a release into the collection system. The verification shall be considered successful when the demonstration shows that the release of urine can be collected with no splash.

Rationale: No further rationale is required.

4.5.3.3.2 Urine Wipes

[HS6022V] The collection and containment of consumable wipes shall be verified by demonstration and inspection. The inspection shall determine the volume of the collection system. The demonstration shall be performed with flight-like hardware independent of gravity. The demonstration shall consist of disposing the consumable wipes into the collection system with a repeat disposal. The verification shall be considered successful when the inspection and demonstration show that the collection system can hold the wipes, wipes are contained, and repeated disposals are contained with no leakage.

Rationale: The verification states that the demonstration shall be completed in an analogous gravity environment. The verification must show that the method of collection and containment will work in the same gravity environments expected during the mission profiles.

4.5.3.3.3 Urine per Crewmember

[HS6023V] The collection and isolation of urine shall be verified by inspection. The inspection shall determine the volume of the collection system. The verification shall be considered successful when the inspection shows that the collection system can collect

Revision: E	Document No: CxP 70024
Release Date: 11/19/10	Page: 254 of 503
Title: Constellation Program Human-Systems Integration Requirements	

and isolate from the crew environment the amount of urine specified by the equation per crewmember for the duration of the mission.

Rationale: No further rationale is required.

4.5.3.3.4 Urine per Hour

[HS6024V] The collection and isolation of urine shall be verified by analysis and demonstration. The analysis shall determine the volume of the collection system and the ability of the system to accommodate urine. The demonstration shall be performed with flight-like hardware. The demonstration shall consist of $n \times 1$ L releases into the collection system in 1 hour, where n is the number of crewmembers per mission (a maximum of 4). The verification shall be considered successful when the analysis and demonstration show that the collection system can collect $n \times 1$ L of urine or simulated urine per hour and isolate it from the crew environment with no leakage.

Rationale: No further rationale is required.

4.5.3.3.5 Urine per Day

[HS6025BV] The collection and isolation of urine shall be verified by analysis. The analysis shall determine the volumetric capacity of the collection system. The verification shall be considered successful when the analysis shows that the collection system can collect and isolate from the crew environment six urinations per crewmember for the duration of the mission.

Rationale: No further rationale is required.

4.5.3.3.6 Urine Rate

[HS6025V] The collection and isolation of urine at a delivery rate shall be verified by demonstration. The demonstration shall be performed with flight-like hardware and shall show the collection system to accommodate the urine delivery rate independent of gravity. The demonstration shall consist of a release into the collection system, and repeated release into the collection system. The verification shall be considered successful when the demonstration shows that the collection system can collect and isolate 1 L of urine from the crew environment at a maximum delivery rate of 50 mL/s.

Rationale: No further rationale is required.

4.5.3.4 Simultaneous Defecation and Urination

4.5.3.4.1 Simultaneous Defecation and Urination

[HS6014V] Simultaneous defecation and urination collection capability shall be verified by analysis and demonstration. The analysis shall include the bodily waste system interface that can accommodate male and female bodies. The demonstration shall be performed by male and female subjects with flight-like hardware. The demonstration shall consist of the subjects using the device for simulated simultaneous defecation and urination without full removal of lower clothing. The verification shall be considered

Revision: E	Document No: CxP 70024
Release Date: 11/19/10	Page: 255 of 503
Title: Constellation Program Human-Systems Integration Requirements	

successful when the analysis and demonstration show containment and no spillage during and after simultaneous collection without completely removing lower clothing.

Rationale: No further rationale is required.

4.5.3.5 Odor Control

4.5.3.5.1 Waste Management Odor Control

[HS6029V] The odor control for waste management equipment shall be verified by demonstration and analysis. The demonstration shall consist of the placement of concentrated odor sources in a flight-like system in a high-fidelity mockup of the waste management system. The demonstration shall include the duration, environmental conditions, and operations of an expected mission. A Crew Consensus evaluation shall determine whether the odor is contained during the demonstration. The analysis shall identify the design features implemented to control odors. The verification shall be considered successful when the Crew Consensus Report from the demonstration and analysis shows that the waste management system odors do not permeate the habitable volume of the vehicle.

Rationale: The magnitude of odor is affected by time duration and temperature. In order to accurately determine whether odor control is attained, these variables should be considered.

4.5.3.5.2 Auditory and Olfactory Privacy

[HS6069V] Not Applicable

4.5.3.6 Waste Management Stowage

4.5.3.6.1 Waste Management Stowage

[HS6030V] Waste management supply accessibility shall be verified by demonstration and analysis. The demonstration shall use a volumetrically accurate high-fidelity mockup. The demonstration shall show access to the supplies while restrained. The analysis shall extrapolate to the minimum and maximum critical dimensions. The verification shall be considered successful when the demonstration and analysis show that all associated equipment and supplies are accessible by the largest male and smallest female crewmembers while located at the waste management station.

Rationale: No further rationale is required.

4.5.3.7 Waste Management Trash

4.5.3.7.1 Waste Management Trash

[HS6031V] Not Applicable

4.5.4 Exercise

Revision: E	Document No: CxP 70024
Release Date: 11/19/10	Page: 256 of 503
Title: Constellation Program Human-Systems Integration Requirements	

4.5.4.1 Exercise Capability

4.5.4.1.1 Exercise Capability

[HS6032V] Time to exercise for missions greater than 8 days shall be verified by analysis. The analysis shall determine the volume necessary to perform exercise and the mission timeline. The verification shall be considered successful when the analysis shows that 30 continuous minutes each day per crewmember is available for missions greater than 8 days.

Rationale: No further rationale is required.

4.5.4.2 Exercise Operational Envelope

4.5.4.2.1 Exercise Operational Envelope

[HS6035V] The exercise envelope shall be verified by inspection. The inspection shall determine the operational envelope for deployed exercise equipment. The inspection shall occur in a volumetrically accurate high-fidelity mockup in nominal non-dynamic mission configuration. The verification shall be considered successful when the inspection shows that the operational envelope available for exercise is 2.23 m x 1.01 m x 1.31 m (7.3 ft x 3.3 ft x 4.3 ft).

Rationale: The astronaut office will have a keen interest in the exercise envelope and, while their approval is not specified in the verification requirement, it is expected that the astronaut office will have input during the design process.

4.5.4.3 Environmental Loads during Exercise

4.5.4.3.1 Thermal Environment During Exercise

[HS6036V] The vehicle's response to environmental loads shall be verified by analysis. The analysis shall evaluate the vehicle systems' response to simultaneous metabolic loads as defined in Appendix E, table Crew Induced Metabolic Loads for a Standard Mission Day With Exercise. The verification shall be considered successful when the analysis shows that the temperature inside the vehicle is maintained within the limits defined in HS3036 and HS3037.

Rationale: No further rationale is required.

4.5.4.3.2 Oxygen Levels During Exercise

[HS6073V] The system's response to environmental loads shall be verified by analysis. The analysis shall evaluate the vehicle systems' response to simultaneous metabolic loads as defined in Appendix E, table Crew Induced Metabolic Loads for a Standard Mission Day With Exercise. The verification shall be considered successful when the analysis shows that oxygen partial pressure inside the habitable volume is maintained within the limits defined in HS3005B.

Rationale: No further rationale is required.

Revision: E	Document No: CxP 70024
Release Date: 11/19/10	Page: 257 of 503
Title: Constellation Program Human-Systems Integration Requirements	

4.5.4.3.3 Carbon Dioxide Levels During Exercise

[HS6037V] The systems' response to environmental loads shall be verified by analysis. The analysis shall evaluate the systems' response to simultaneous metabolic loads as defined in Appendix E, table Crew Induced Metabolic Loads for a Standard Mission Day With Exercise. The verification shall be considered successful when the analysis shows that CO₂ inside the vehicle is maintained within the limits defined in HS3005.

Rationale: No further rationale is required.

4.5.4.3.4 Relative Humidity During Exercise

[HS6038V] The system's response to environmental loads shall be verified by analysis. The analysis shall evaluate the vehicle systems' response to simultaneous metabolic loads as defined in Appendix E, table Crew Induced Metabolic Loads for a Standard Mission Day With Exercise. The verification shall be considered successful when the analysis shows that water vapor inside the habitable volume is maintained within the limits defined in HS3046.

Rationale: No further rationale is required.

4.5.5 Space Medicine

4.5.5.1 Data and Communications

4.5.5.1.1 Private Voice

[HS6075V] The system's two-way private voice communication shall be verified by demonstration. The demonstration shall be an integrated demonstration and shall consist of communications between the vehicle and designated Launch Control Center (LCC) and Mission Control Center (MCC) flight control team positions using flight-like avionics. The verification shall be considered successful when the demonstration shows that audio transmitted between the vehicle and the Launch Control Center and the Mission Control Center can only be heard in the vehicle and at the designated flight control team positions.

Rationale: The Orion and Altair vehicles are only responsible for sending and receiving voice communication for this requirement. The Ground Operations and Mission Systems will be responsible for providing the two-way private voice communication during the various mission phases.

4.5.5.1.2 Private Video

[HS6076V] The system's private video communication shall be verified by test. The test shall be an integrated test and shall consist of a simulated video communication between the vehicle and designated Mission Control Center Flight control team positions using flight-like avionics. The verification shall be considered successful when the test shows that video transmitted between the vehicle and the Mission Control Center can only be seen on orbit and at the designated flight control team positions.

Revision: E	Document No: CxP 70024
Release Date: 11/19/10	Page: 258 of 503
Title: Constellation Program Human-Systems Integration Requirements	

Rationale: No further rationale is required.

4.5.5.1.3 Communication Capabilities

[HS6097V] Audio, text, and video uplink and downlink capabilities shall be verified by demonstration. The demonstration shall consist of using the flight communication systems to exchange information with earth-bound individuals. The verification shall be considered successful when the demonstration shows that crewmembers can exchange audio, text, and video information with earth-bound individuals using flight communication systems with a delivery delay of less than 4 hours.

Rationale: No further rationale is required.

4.5.5.1.4 Personalized In-Flight Updates

[HS6099V] Updating personalized database in-flight shall be verified by demonstration. The demonstration shall consist of using the flight communication systems to update the personalized recreational on-board database from the mission systems. The verification shall be considered successful when the personalized on-board database is accurately updated.

Rationale: No further rationale is required.

4.5.5.1.5 Biomedical Data

[HS6077V] The collection of biomedical telemetry from the suit shall be verified by test. The test shall be an integrated test and consist of sending a simulated biomedical telemetry from the suit to the vehicle using flight-like hardware. The verification shall be considered successful when the demonstration shows that biomedical telemetry is transmitted from the pressure suit to the vehicle.

Rationale: No further rationale is required.

4.5.5.1.6 Biomedical Relay

[HS6078V] The relay of suited biomedical telemetry shall be verified by test. The test shall be an integrated test and shall consist of transmitting biomedical telemetry to the Mission Control Center using flight-like avionics. The verification shall be considered successful when the test shows that biomedical telemetry is accurately transmitted to the Mission Control Center.

Rationale: No further rationale is required.

4.5.5.1.7 Biomedical Display

[HS6079V] The display of biomedical telemetry to crewmembers shall be verified by demonstration. The demonstration shall send simulated biomedical telemetry to the crew displays using flight-like hardware. The verification shall be considered successful when the demonstration shows that biomedical telemetry is displayed to crewmembers.

Rationale: No further rationale is required.

Revision: E	Document No: CxP 70024
Release Date: 11/19/10	Page: 259 of 503
Title: Constellation Program Human-Systems Integration Requirements	

4.5.5.2 Orthostatic Protection

4.5.5.2.1 Orthostatic Protection

[HS6082V] The provisioning of crewmember orthostatic protection shall be verified by analysis. The analysis shall identify the vehicle's countermeasure capabilities to combat end of mission orthostasis. The verification shall be considered successful when it is shown the vehicle protects the crewmember from orthostatic fluid shifts during re-entry and landing while allowing the crewmember to complete tasks associated with those mission phases.

Rationale: No further rationale is required.

4.5.5.3 Medical Area and Capability

4.5.5.3.1 Medical Care Provider Access

[HS6083V] The medical provider access to ill or injured crewmember shall be verified by demonstration and analysis. The demonstration shall consist of a subject providing medical treatment to another subject in the medical area within a volumetrically accurate mockup. The analysis shall extrapolate the demonstration to include all applicable mission phases. The verification shall be considered successful when the demonstration and analysis show that a medical provider can access the ill or injured crewmember in the medical area to provide various levels of care during all applicable mission phases.

Rationale: No further rationale is required.

4.5.5.3.2 Patient Electrical Isolation

[HS6084V] The patient electrical isolation shall be verified by analysis. The analysis shall determine how a crewmember will be restrained in the medical seat for defibrillation. The analysis shall evaluate how electrical isolation from the vehicle is achieved. The verification shall be considered successful when the analysis shows that a crewmember is electrically isolated from the rest of the vehicle.

Rationale: No further rationale is required.

4.5.5.3.3 Access to Medical Equipment

[HS6085V] The interfaces from medical equipment to patient shall be verified by demonstration. The demonstration shall configure pieces of medical hardware secured and being used with a surrogate ill or injured crewmember in the medical area in a volumetrically accurate mockup. The verification shall be considered successful when the hardware interfaces with the surrogate as required, performing the function safely.

Rationale: No further rationale is required.

Revision: E	Document No: CxP 70024
Release Date: 11/19/10	Page: 260 of 503
Title: Constellation Program Human-Systems Integration Requirements	

4.5.5.3.4 Access to Deployed Medical Kits

[HS6086V] The medical kit proximity to the provider shall be verified by analysis and demonstration. The analysis shall consist of a worksite analysis to determine where the medical kits shall be deployed. The demonstration shall consist of a crewmember performing the role of the medical care provider, and another crewmember performing the role of patient in a volumetrically accurate mockup. The verification shall be considered successful when the worksite analysis to determine locations for the medical kits has been completed, and the demonstration shows that the medical provider can reach both the crewmember and the medical kit.

Rationale: A worksite analysis and demonstration will determine if all medical provider tasks can be completed when considering the identified location of the deployed medical kits.

4.5.5.3.5 Medical Care Capabilities

[HS6101V] The medical care capabilities shall be verified by inspection. The inspection shall confirm closure of the requirements in CxP 70035, Constellation Program Portable Equipment, Payloads, and Cargo (PEPC) Interface Requirements Document, and the Portable Equipment SRD, for the mission's level of care capabilities in HS6101, table Medical Care Capabilities. The verification shall be considered successful when the inspection shows that the requirements in CxP 70035 and the Portable Equipment SRD are closed.

Rationale: No further rationale is required.

4.5.5.4 Crew Sleep Accommodations

4.5.5.4.1 Crew Sleep Accommodations

[HS6104V] Accommodations for crew sleep shall be verified by inspection. The inspection shall consist of a review of engineering drawings and the available restraints to maintain a sleeping position. The verification shall be considered successful when the inspection shows that accommodations for crew sleep have been provided.

Rationale: No further rationale is required.

4.5.6 Stowage

4.5.6.1 Stowage Nominal Operation

[HS6044V] Not Applicable

4.5.6.2 Stowage Location

[HS6046V] Not Applicable.

4.5.6.3 Stowage Arrangement

[HS6047V] Not Applicable

Revision: E	Document No: CxP 70024
Release Date: 11/19/10	Page: 261 of 503
Title: Constellation Program Human-Systems Integration Requirements	

4.5.6.4 Stowage Reconfiguration

[HS6049V] Not Applicable

4.5.6.5 Stowage Restraints

[HS6050V] The restraint of stowed items during periods of expected acceleration and vibration shall be verified by analysis. The analysis shall evaluate the effect of expected acceleration and vibration on the restraints of stowed items. The verification shall be considered successful when the analysis shows that the restraint system is sufficient for the volume and mass of stowed items.

Rationale: No further rationale is required.

4.5.6.6 Stowage Equipment Cover Restraint

[HS6106V] The restraint of stowage or containment equipment cover in an open position shall be verified by analysis and demonstration. The analysis shall identify the intended use of the stowage container including the likely size and configuration of its contents. The analysis shall also evaluate and characterize the expected acceleration and vibration environment that the stowage system will be exposed to during its intended use. The demonstration shall consist of a high-fidelity mockup or flight system and stowage system contents, and will show that the stowage system cover can be mechanically secured in an open position sufficient to access, extract, and return contents without being supported by hand. The verification shall be considered successful when the analysis and demonstration show that the cover restraint system is sufficient to keep the cover in the open position in the expected acceleration and vibration environments.

Rationale: No further rationale is required.

4.5.6.7 Stowage Hand Operation

[HS6051V] The tool-free operation of stowage systems shall be verified by demonstration. The demonstration shall be performed using high-fidelity stowage components. The demonstration shall consist of a subject accessing and operating stowage compartments. The verification shall be considered successful when the demonstration shows that all stowage compartments are accessible and operable without the use of any tools.

Rationale: No further rationale is required.

4.5.6.8 Stowage Commonality

[HS6052V] Not Applicable

4.5.6.9 Stowage Compatibility with Inventory Management

[HS6053V] The stowage system's compatibility with the inventory management system shall be verified by analysis. The analysis shall determine if the inventory management

Revision: E	Document No: CxP 70024
Release Date: 11/19/10	Page: 262 of 503
Title: Constellation Program Human-Systems Integration Requirements	

system can be used with all stowage without modification. The verification shall be considered successful when the analysis shows that the stowage system can be inventoried by the inventory management system.

Rationale: No further rationale is required.

4.5.7 Trash Management

4.5.7.1 Trash Management Nominal Operation

[HS6054V] Not Applicable

4.5.7.2 Trash Management Odor Control

[HS6056V] The odor control for trash management equipment shall be verified by demonstration and analysis. The demonstration shall consist of the placement of concentrated odor sources in a flight-like system in a high-fidelity mockup of the trash management system. The demonstration shall include the duration, environmental conditions, and operations of an expected mission. A crew consensus evaluation shall determine whether the odor is contained during the demonstration. The analysis shall identify the design features implemented to control odors. The verification shall be considered successful when the demonstration and analysis show that the trash management system odors do not permeate the habitable volume of the vehicle.

Rationale: The magnitude of odor is affected by time duration and temperature. These variables should be considered in order to accurately determine whether odor control is attained.

4.5.7.3 Trash Management Contamination Control

[HS6057V] The prevention of trash release shall be verified by analysis. The analysis shall include a review of the trash management system design. The analysis shall examine data samples gathered from the surrounding environment after repeated operations of the trash management system where microorganisms are present. The verification shall be considered successful when the analysis shows that microorganisms in trash are not released outside of the trash management system.

Rationale: No further rationale is required.

4.5.7.4 Trash Management Hazard Containment

[HS6058V] The trash management containment of its contents shall be verified by demonstration. The demonstration shall consist of disposing items, including biological waste, into the trash management system and showing that containment is independent of gravity. The verification shall be considered successful when the demonstration shows that the trash management system contains these waste items.

Rationale: No further rationale is required.

Revision: E	Document No: CxP 70024
Release Date: 11/19/10	Page: 263 of 503
Title: Constellation Program Human-Systems Integration Requirements	

4.6 CREW INTERFACES

4.6.1 General

4.6.1.1 Consistent Crew Interfaces

[HS7007V] Not Applicable

4.6.1.2 Labeling

[HS7036V] Labeling shall be verified by inspection. The verification shall be considered successful when the inspection of the vehicle Label Plan indicates that all crew interface items have an associated label that complies with the requirements in CxP 70152, Constellation Program Crew Interface Labeling Standard.

Rationale: No further rationale is required.

4.6.1.3 Nomenclature

[HS7079V] Nomenclature compliance to CxP 70172-01, Constellation program Data Architecture Specification, Volume 1: Naming and Identification Rules shall be verified by inspection. The verification shall be considered successful when the inspection indicates that all nomenclature items related to on-orbit operations have been approved by a panel chartered under the CxSECB as outlined in CxP 70172-01.

Rationale: No further rationale is required.

4.6.1.4 Legibility

[HS7044V] The legibility of crew interfaces shall be verified by analysis and test. The analysis shall consist of a task analysis and an analysis of relevant legibility data to identify the interfaces that need to be read and interpreted, and the set of worst-case expected conditions during a nominal mission profile that need to be tested. The test shall consist of a legibility test conducted with a minimum of 5 crewmembers, crew designated representatives, or engineering subjects, under the identified list of conditions in a high fidelity flight-like simulator or mockup. The legibility test shall consist of rapid serial visual presentation and subsequent verbal identification by subjects of a representative selection of targets such as hardware labels and software elements (alphanumeric, icons, and symbols). The verification shall be considered successful when the test shows an average identification accuracy of 98% for each type of target.

Rationale: Legibility verification testing of selected interfaces should be preceded by legibility testing of a broader selection of interfaces during the development cycle. This may be done in conjunction with usability testing, and will help ensure that interfaces selected for verification testing, as well as interfaces not selected for verification testing would have a high probability of passing the legibility requirement. The accuracy rate in this requirement is

Revision: E	Document No: CxP 70024
Release Date: 11/19/10	Page: 264 of 503
Title: Constellation Program Human-Systems Integration Requirements	

supported by ISO 9241-11:1998(E) which is based on data from unsuited subjects.

4.6.1.5 Language

[HS7064V] The American English language requirement shall be verified by inspection. The inspection shall be performed on display text, hardcopy procedures and cue cards, labels, and placards. The verification shall be considered successful when the inspection shows that all text is found to be written in the American English language based on Webster's New World Dictionary of American English, and all acronyms and terms used shall be based on the Cx Common Glossary & Acronyms: <https://ice.exploration.nasa.gov/confluence/pages/viewpage.action?pageId=11267>.

Rationale: This requirement may be a candidate for a higher-level document. It resides in the HSIR until another appropriate document is identified. The verification may change or may not be necessary.

4.6.1.6 Use of Color

[HS7065AV] The redundancy of color interface cues shall be verified by demonstration. The demonstration shall first identify all interface components that use color to convey meaning. The demonstration shall then determine whether the identified color-coded interface components also provide a second cue to convey that meaning. The verification shall be considered successful when the demonstration shows that all color-coded interface components provide a second noncolor cue when color is used to convey meaning.

Rationale: Demonstration is used to account for situations that involve processes or caution and warning, which would require interaction with the system rather than inspection of the system/drawings.

4.6.2 Crew Performance

4.6.2.1 Crew Interface Usability

4.6.2.1.1 Crew Interface Usability

[HS7066V] Crew interface usability shall be verified by analysis and test. The analysis shall identify the list of tasks to be performed and the potential errors that can be encountered using standard task analysis methods. The test shall consist of usability evaluations based on standard best practices (e.g., Jacob Nielsen's "Usability Engineering", 1993). During the usability evaluation, a minimum of 20 crewmembers or crew designated representatives will perform a set of NASA-approved onboard tasks in a high-fidelity flight-like simulator or mockup. Usability evaluations should include collection of data such as completion times and ratings on subjective questionnaires that will help differentiate design-induced errors from errors related to human reliability. For the usability evaluation, a task is defined as an activity driven by a procedure. The procedure consists of a series of task steps, where a task step is defined as a single instruction to the crewmember, as is typical of current spaceflight procedures. Each

Revision: E	Document No: CxP 70024
Release Date: 11/19/10	Page: 265 of 503
Title: Constellation Program Human-Systems Integration Requirements	

task must be completed; failed or incomplete tasks do not pass verification. Participants should maintain task completion times commensurate with the performance requirements of the particular task. The percentage of erroneous task steps for each participant is calculated by dividing the number of erroneous task steps by the total number of task steps and multiplying the result by 100. Likewise, the percentage of participants committing each erroneous task step is calculated by dividing the number of participants committing each erroneous task step by the total number of participants and multiplying the result by 100. The verification shall be considered successful when the results of the analysis and test show that the percentage of erroneous task steps per participant is no greater than 5%, and the percentage of participants who committed each erroneous task step is no greater than 10%.

Rationale: Although errors are often calculated as averages across participants, the approach used in this verification (calculating errors per participant and per task step) ensures that the number of design-induced errors of every task step and every participant is minimized. The approach puts the emphasis on identifying usability problems, rather than just calculating an overall error rate. When more than 10% of participants commit the same erroneous task step, this indicates a serious design issue. When one or more participants commit more than 5% erroneous task steps across the task, this again could indicate serious design issues. If a single participant commits more than 5% erroneous task steps, this could indicate an issue such as deficiency in training or fatigue. In this case, results should be discussed with NASA. Usability verification can be accomplished along with other verifications in well-planned human-in-the-loop evaluations.

4.6.2.2 Crew Cognitive Workload

4.6.2.2.1 Workload Measure: Nominal

[HS7080V] The workload rating for crew tasks shall be verified by analysis and test. The analysis shall consist of a task analysis to identify a list of NASA approved nominal tasks to be performed. The test shall consist of an evaluation by at least eight trained personnel who are crew or designated crew representatives performing each of the listed crew tasks in a flight-like simulator or mockup (i.e., a facility that is determined to be as close to flight like as is possible) and providing workload ratings on the Bedford Workload Scale. Tasks will be grouped so that related tasks will be performed concurrently and sequentially as expected during actual in-flight operations. When tasks are designed to be performed by multiple crewmembers, multiple personnel shall participate in the test and provide individual workload ratings. The evaluation period for each task shall span the duration of the task with personnel providing their ratings at the end of this period. During workload evaluation tests, personnel will maintain performance error rates and completion times commensurate with the performance requirements of the particular task. The verification shall be considered successful when the analysis in conjunction with the test results show that for representative nominal tasks identified in the analysis, at least 6 of the 8 ratings are no greater than a

Revision: E	Document No: CxP 70024
Release Date: 11/19/10	Page: 266 of 503
Title: Constellation Program Human-Systems Integration Requirements	

rating of 3 on the Bedford workload scale, while up to 2 of the 8 ratings may exceed the rating of 3 (allowing workload ratings of 4, 5, or 6 on the Bedford workload scale). For any ratings of 4, 5, or 6, a consensus must be reached by all of the participants indicating that the workload is acceptable in order for verification to be considered successful.

Rationale: Workload must be assessed repeatedly by highly trained individuals using a consistent methodology immediately following dynamic human-in-the-loop simulations of tasks. A key element of testing in a flight-like simulator or mockup is that the quality of error (i.e., consequences or penalties) is commensurate to the respective nominal, loss of mission, loss of crew, or loss of vehicle task or operational scenario. Workload should also be assessed in the design phase, prior to verification (including multi-dimensional tools such as the NASA-TLX), to ensure that the design or task does not induce unnecessary workload. The Bedford scale is appropriate for verification because it provides anchors for every rating, is familiar to the crew population, and provides a decision gate in which ratings above this gate are indicative of workload that is not satisfactory without a reduction in spare capacity. When using the Bedford scale, each subject must be briefed as to what each of the ratings on the scale mean, the task they are rating, the time period over which to make the rating, and the other tasks for which they need to judge their spare capacity. These items need to be consistent across subjects for each task. The Bedford scale is not linear and the underlying distribution is not predicted to be normal, thus calculation of a mean and median or the uses of parametric statistics are not appropriate. The Bedford scale allows for half ratings (e.g., 1.5), which is also allowed here, as long as the rating is less a 3 or less. A rating of 3.5 or higher is only acceptable for verification of this requirement if a consensus of all participants indicates that the workload is acceptable.

4.6.2.2 Workload Measures: Off-Nominal

[HS7080AV] The workload rating for crew tasks shall be verified by analysis and test. The analysis shall consist of a task analysis to identify a list of NASA approved off-nominal tasks to be performed. The test shall consist of an evaluation by at least eight trained personnel who are crew or designated crew representatives, and are representative of the crew population performing each of the listed crew tasks in a flight-like simulator or mockup (i.e., a facility that is determined to be as close to flight like as is possible) and providing workload ratings on the Bedford Workload Scale. Tasks will be grouped so that related tasks will be performed concurrently and sequentially as expected during actual in-flight operations. When tasks are designed to be performed by multiple crewmembers, multiple personnel shall participate in the test and provide individual workload ratings. The evaluation period for each task shall span the duration of the task with personnel providing their ratings at the end of this period. During workload evaluation tests, personnel will maintain performance error rates and completion times commensurate with the performance requirements of the particular task. The verification shall be considered successful when the analysis in conjunction

Revision: E	Document No: CxP 70024
Release Date: 11/19/10	Page: 267 of 503
Title: Constellation Program Human-Systems Integration Requirements	

with the test results show that for representative off-nominal tasks identified in the analysis, all of the subjects provide a rating of 6 or less on the Bedford scale.

Rationale: Workload must be assessed repeatedly by highly trained individuals using a consistent methodology immediately following dynamic human-in-the-loop simulations of tasks. A key element of testing in a flight-like simulator or mockup is that the quality of error (i.e., consequences or penalties) is commensurate to the respective nominal, loss of mission, loss of crew, or loss of vehicle task or operational scenario. Workload should also be assessed in the design phase, prior to verification (including multi-dimensional tools such as the NASA-TLX), to ensure that the design or task does not induce unnecessary workload. The Bedford scale is appropriate for verification because it provides anchors for every rating, is familiar to the crew population, and provides a decision gate in which ratings above this gate are indicative of workload that is not satisfactory without a reduction in spare capacity and a gate in which ratings above this gate are indicative of workload that is not tolerable for the task. When using the Bedford scale, each subject must be briefed as to what each of the ratings on the scale mean, the task they are rating, the time period over which to make the rating, and the other tasks for which they need to judge their spare capacity. These items need to be consistent across subjects for each task. The Bedford scale is not linear and the underlying distribution is not predicted to be normal, thus calculation of a mean and median or the uses of parametric statistics are not appropriate. This verification requires that every subject's raw score is a 6 or less on the Bedford scale. The Bedford scale allows for half ratings (e.g., 1.5), which is also allowed here, as long as the rating is a 6 or less. A rating of 6.5 or higher is not acceptable for verification of this requirement. A rating of 6 or less is acceptable for this verification because workload is expected to be higher under off-nominal than nominal conditions, but workload is still rated as tolerable for the task.

4.6.2.3 Handling Qualities

4.6.2.3.1 Handling Qualities for Manual Control – Level 1

[HS7003V] Handling qualities shall be verified by analysis and test. Selected manual control scenarios will be defined via review of potential manual control scenarios and associated manual control modes, with the selected manual control scenarios scoped with Program agreement. For each selected scenario, a list of handling quality related tasks will be generated as part of a task analysis. A handling quality related task is defined as the manual control capability that is being rated with the Cooper-Harper Rating Scale. Each task within a scenario is rated separately and must meet Level 1 (handling quality ratings of 1, 2 or 3). A test shall be conducted for each selected scenario with at least five crew trained as operators performing the listed control tasks in a flight-like simulator or mockup and providing handling-quality ratings on the Cooper-Harper scale for each task in the scenario. The verification shall be considered successful when the test shows that for each task associated with each of the selected

Revision: E	Document No: CxP 70024
Release Date: 11/19/10	Page: 268 of 503
Title: Constellation Program Human-Systems Integration Requirements	

manual control scenarios, at least 60% of the ratings are Level 1 (handling quality ratings of 1, 2 or 3), while up to 40% may exceed Level 1 with a Level 2 rating (handling quality rating of 4, 5, or 6). For any ratings of 4, 5, or 6, a consensus must be reached by all of the participants indicating that handling qualities are acceptable in order for verification to be considered successful.

Rationale: No further rationale is required.

4.6.2.3.2 Handling Qualities for Manual Control – Level 2

[HS7004V] Handling qualities shall be verified by analysis and test. These selected special case scenarios will be pre-declared as Level 2 appropriate scenarios a priori based on identified degradation of flight controls or severe and multiple failures, and not merely as the result of a failure to meet Level 1. Special case manual control scenarios will be defined via review of potential manual control scenarios and associated manual control modes, with the selected special case manual control scenarios scoped with Program agreement. For each selected special case scenario, a list of handling quality related tasks will be generated as part of a task analysis. A handling quality related task is defined as the manual control capability that is being rated with the Cooper-Harper Rating Scale. Each task within a special case scenario is rated separately and must exhibit at least Level 2 handling qualities (handling quality ratings of 1, 2, 3, 4, 5, or 6). A test shall be conducted for each selected scenario with at least five crew trained as operators performing the listed tasks in a flight-like simulator or mockup, providing handling-quality ratings on the Cooper-Harper scale for each task in the scenario. The verification shall be considered successful when the test shows that each task associated with each special case manual control scenario results in Level 2 ratings or better (handling quality ratings of 1, 2, 3, 4, 5, or 6).

Rationale: No further rationale is required.

4.6.3 Display and Control Layout

4.6.3.1 Viewing Requirements

4.6.3.1.1 Field of View

[HS7010V] The visibility of viewed displays and controls shall be verified by analysis. The analysis shall consist of a geometric worst-case calculation of the field of regard of a suited and seated crewmember. The verification shall be considered successful when the analysis shows that all displays and controls, which need to be viewed for operation, are fully within the field of view of a suited and seated crewmember.

Rationale: No further rationale is required.

4.6.3.1.2 Two-Crew Operations

[HS7010AV] The capability of two operators to view and confirm each other's inputs for mission critical functions shall be verified by demonstration. The demonstration shall use a list of mission critical functions determined by a task analysis. The demonstration

Revision: E	Document No: CxP 70024
Release Date: 11/19/10	Page: 269 of 503
Title: Constellation Program Human-Systems Integration Requirements	

shall include two trained personnel performing mission critical functions in a flight-like simulator or mockup with the flight configuration of seating, controls, and displays. The verification shall be considered successful when the demonstration shows that the vehicle provides a display location for personnel to view each other's operations for all mission critical functions.

Rationale: No further rationale is required.

4.6.3.1.3 Viewing Critical Displays and Controls

[HS7018] Not Applicable

4.6.3.1.4 Viewing Frequently Used Displays and Controls

[HS7018A] Not Applicable

4.6.3.1.5 Obscured Controls

[HS7067V] Distinguishability of out-of view controls shall be verified by test. The test shall consist of suited and seated operators using the out-of-view controls in a range of assigned control tasks. The verification shall be considered successful when the test shows that the operators correctly distinguished the out-of-view controls during the tasks such that there is 95% confidence that operators will make less than 1% erroneous control selections.

Rationale: No further rationale is required.

4.6.3.1.6 Self-Illuminated Controls and Displays

[HS7082V] Self-illumination for displays and controls shall be verified by analysis and demonstration. A task analysis shall identify the displays and controls that require self-illumination, considering the likely ambient lighting conditions, general panel illumination, and cabin darkening. The demonstration shall occur in a flight vehicle or high-fidelity mockup and will consist of observing the displays and controls in all likely ambient lighting conditions. The verification shall be considered successful when the analysis and demonstration show that the identified displays and controls can be clearly observed and distinguished in the likely lighting conditions.

Rationale: No further rationale is required.

4.6.3.2 Reach Requirements

4.6.3.2.1 Functional Reach Envelope

[HS7019V] The location of controls within the crewmembers' functional reach shall be verified by analysis. The analysis shall consist of a geometric worst-case calculation of the reach envelope of a suited and seated crewmember. The verification shall be considered successful when the analysis shows that all controls for each task are located within the reach envelope of the seated and suited crewmember performing the task.

Revision: E	Document No: CxP 70024
Release Date: 11/19/10	Page: 270 of 503
Title: Constellation Program Human-Systems Integration Requirements	

Rationale: No further rationale is required.

4.6.3.2.2 Reach for Critical Controls

[HS7021V] Not Applicable

4.6.3.2.3 Reach for Frequently Used Controls

[HS7021AV] Not Applicable

4.6.3.3 Display and Control Grouping

4.6.3.3.1 Functional Related Displays and Controls

[HS7022V] Not Applicable

4.6.3.3.2 Successive Operation of Displays and Controls

[HS7023V] Not Applicable

4.6.3.4 Control Spacing

4.6.3.4.1 Control Spacing for Suited Operations

[HS7024V] Spacing of hand operated controls for gloved operations shall be verified by demonstration. The demonstration shall be performed using a list of controls used by gloved crewmembers as determined by a task analysis. The demonstration will use trained personnel, wearing a flight-like glove, representing the full anthropometric range of crewmembers. The demonstration will be conducted in a flight-like simulator or mockup. The verification shall be considered successful when the demonstration shows that hand operated controls used for gloved operations are spaced such that the controls can be operated without interfering with nearby controls.

Rationale: No further rationale is required.

4.6.3.4.2 Control Spacing for Unsited Operations

[HS7925V] Spacing of hand operated controls for ungloved operations shall be verified by demonstration. The demonstration shall be performed using a list of controls used by ungloved crewmembers as determined by a task analysis. The demonstration will use trained personnel representing the full anthropometric range of crewmembers. The demonstration will be conducted in a flight-like simulator or mockup. The verification shall be considered successful when the demonstration shows that hand operated controls used for ungloved operations are spaced such that the controls can be operated.

Rationale: No further rationale is required.

4.6.4 Displays

Revision: E	Document No: CxP 70024
Release Date: 11/19/10	Page: 271 of 503
Title: Constellation Program Human-Systems Integration Requirements	

4.6.4.1 Display Content

4.6.4.1.1 Task-Oriented Displays

[HS7059V] The availability of task-oriented displays shall be verified by inspection. The inspection shall determine the availability of a task-oriented display for each task. The verification shall be considered successful when the inspection confirms the existence of a task-oriented display associated with each task.

Rationale: No further rationale is required.

4.6.4.1.2 Subsystem-Oriented Displays

[HS7060V] The availability of subsystem-oriented displays shall be verified by inspection. The inspection shall determine the availability of a subsystem-oriented display for each subsystem. The verification shall be considered successful when the inspection confirms the existence of a subsystem-oriented display associated with each subsystem.

Rationale: No further rationale is required.

4.6.4.1.3 Viewing Simultaneous Task Information

[HS7060AV] Not Applicable

4.6.4.1.4 Viewing Simultaneous Critical Task Information

[HS7070V] Simultaneous viewing of critical task information shall be verified by analysis. The analysis shall determine for each critical task whether or not all of the task information needed to perform the task can be simultaneously displayed within the field of regard of a suited and seated crewmember performing the task. The verification shall be considered successful when the analysis shows that the vehicle can simultaneously display all information needed for each critical task within the field of regard of a single seated and suited crewmember.

Rationale: No further rationale is required.

4.6.4.2 Display Hierarchy

4.6.4.2.1 Location Within the Display Hierarchy

[HS7061V] Location within the visual display hierarchy shall be verified by demonstration. The demonstration shall consist of navigation through each of the displays using flight software and flight-like display device hardware. The verification shall be considered successful when the demonstration shows that each display offers an opportunity to view one's location within the display hierarchy.

Rationale: No further rationale is required.

4.6.4.2.2 Access Within Display Hierarchy

[HS7071V] Not Applicable

Revision: E	Document No: CxP 70024
Release Date: 11/19/10	Page: 272 of 503
Title: Constellation Program Human-Systems Integration Requirements	

4.6.4.3 System Feedback

4.6.4.3.1 State Change

[HS7072V] Data update rate for state change shall be verified by test. The test shall be performed with flight-configuration software and hardware. The test shall run a scenario that simulates a display parameter changing on multiple displays. The verification shall be considered successful when the test shows that the changed data parameter is updated within 1 second on all displays that show the data.

Rationale: No further rationale is required.

4.6.4.3.2 Lost Data

[HS7072AV] Loss of displayed data parameters shall be verified by demonstration. The demonstration shall be performed using flight-configuration software and a list of representative data types from a task analysis. The software shall run a scenario that results in the loss of data parameters for the data sets being tested. The verification shall be considered successful when the demonstration shows that the vehicle provides an indication that the parameters for each tested data set are unavailable.

Rationale: No further rationale is required.

4.6.5 Hardware and Software Controls

4.6.5.1 Control Operation

4.6.5.1.1 Compatibility of Movement

[HS7063V] Input-output compatibility shall be verified by demonstration. The demonstration shall use flight-configuration hardware and software controls. The demonstration shall consist of activation of the controls and noting the control response. The verification shall be considered successful when the demonstration shows that the input-output mapping is compatible as defined in Appendix K, table Input-Output Compatibility.

Rationale: No further rationale is required.

4.6.5.1.2 Control Feedback

[HS7063AV] Feedback of crew-initiated control activation shall be verified by demonstration. The demonstration shall consist of simulating crew activation of flight-configuration hardware and software controls. The verification shall be considered successful when the demonstration shows that all control systems provide an indication of crew-initiated control activations.

Rationale: No further rationale is required.

4.6.5.1.3 Protection Against Inadvertent Activation

[HS7063BV] Not Applicable.

Revision: E	Document No: CxP 70024
Release Date: 11/19/10	Page: 273 of 503
Title: Constellation Program Human-Systems Integration Requirements	

4.6.5.1.4 Protection for Flight Actuated Critical Controls

[HS7063CV] Protection against inadvertent actuation of mission critical and safety critical controls by the crew shall be verified by analysis and demonstration. The task analysis shall identify all mission and safety critical flight-configuration hardware and software controls. The demonstration shall consist of the activation of the controls identified in the task analysis. The verification shall be considered successful when the demonstration shows that the controls have two independent crew actions for activation.

Rationale: No further rationale is required.

4.6.5.1.5 Protection for Ground Actuated Critical Controls

[HS7083V] The ability of the system to protect against a single inadvertent actuation of mission and safety critical controls using a two-step process of two independent ground personnel actions shall be verified by analysis and inspection. The analysis shall consist of review and assessment of MS and Ground Systems (GS) facilities designs and hazard analyses. The inspection shall consist of review of the allocated MS and GS SRD sections requirements. The inspection shall be considered successful when the allocated MS and GS SRDs requirements are closed. The analysis shall be considered successful when the assessment of the MS and GS facilities designs and closure of the hazard analysis confirm the ability of the system to protect against a single inadvertent actuation of mission and safety critical controls using a two-step process of two independent ground personnel actions.

Rationale: No further rationale is required.

4.6.5.1.6 Coding for Emergency Controls

[HS7063DV] Coding for emergency controls shall be verified by inspection. The inspection shall involve all controls on the list of emergency controls as defined in a NASA-approved task analysis. The inspection shall include a review of the vehicle Label Plan and determine whether coding is compliant with the emergency coding defined in CxP 70152, Constellation Program Crew Interface Labeling Standard. The verification shall be considered successful when the inspection shows that coding meets the emergency coding defined in CxP 70152, Constellation Program Crew Interface Labeling Standard.

Rationale: No further rationale is required.

4.6.5.1.7 Restraints for Control Operation

[HS7063EV] Restraints for reduced gravity control operations shall be verified by analysis. The analysis will use a list of controls required during reduced gravity crew operations as determined by a task analysis. The analysis shall consist of computer models of the forces during control operations to determine if the restraints will allow proper operation of controls, taking into account the full anthropometric range and force capabilities of crewmembers. The verification shall be considered successful when the

Revision: E	Document No: CxP 70024
Release Date: 11/19/10	Page: 274 of 503
Title: Constellation Program Human-Systems Integration Requirements	

analysis shows that the restraint systems provided allow proper application of the forces necessary for the full range of operation of controls used during reduced gravity.

Rationale: No further rationale is required.

4.6.5.2 High-g Operations

4.6.5.2.1 Over 3 g

[HS7027V] Control placement for operations at 3 g or more shall be verified by analysis. The analysis shall be performed using a list of controls used during operations at 3 g or more as determined by a task analysis. The analysis shall determine whether the controls can be accessed by a hand/wrist movement of a restrained/supported arm taking into account the full anthropometric range of crewmembers. The verification shall be considered successful when the analysis shows that controls used in operations at 3 g or more are accessible by hand/wrist movements of a restrained/supported arm.

Rationale: No further rationale is required.

4.6.5.2.2 Over 2 g

[HS7028V] Control placement for operations between 2 g and 3 g shall be verified by analysis. The analysis shall be performed using a list of controls used during operations between 2 g and 3 g as determined by a task analysis. The analysis shall determine whether the controls can be accessed either by hand/wrist movements of a restrained/supported arm or by forward reaches taking into account the full anthropometric range of crewmembers. The verification shall be considered successful when the analysis shows that controls used during operations between 2 g and 3 g are accessible by hand/wrist movements of a restrained/supported arm or by a reach within a forward +/- 30 degree cone.

Rationale: No further rationale is required.

4.6.5.2.3 Supports

[HS7029V] Limb support for control operations during acceleration levels above 2 g shall be determined by analysis. A task analysis shall identify the control tasks that will require stabilizing supports above 2 g and the performance standards required. A modeling analysis shall be performed by using a CAD model to determine the support placement for limbs during the identified controls tasks. The verification shall be considered successful when the analysis shows that limb support is sufficient to achieve identified performance standards for the control tasks.

Rationale: This requirement emphasizes the need to verify that support systems (in conjunction with the control interfaces) will maintain crew performance at or above defined standards while the task is performed under the anticipated sustained and stochastic acceleration profile.

Revision: E	Document No: CxP 70024
Release Date: 11/19/10	Page: 275 of 503
Title: Constellation Program Human-Systems Integration Requirements	

4.6.6 Crew Notifications and Caution and Warning

4.6.6.1 Crew Notifications

4.6.6.1.1 Notifications

[HS7049V] Crew notification of required mission critical actions shall be verified by demonstration. The demonstration shall use a list of mission critical action scenarios as determined from a task analysis. The demonstration shall be performed with flight hardware and software running the mission critical action scenarios. The verification shall be considered successful when the demonstration shows that notifications are received when mission critical actions are required.

Rationale: No further rationale is required.

4.6.6.1.2 Manual Silencing

[HS7049AV] The manual silencing feature for auditory annunciators shall be verified by demonstration. The demonstration shall be performed on flight-configuration hardware and software. The annunciators will be activated and the manual silencing feature will be selected. The verification shall be considered successful when the demonstration shows that activating the manual silencing feature silences the active auditory annunciators.

Rationale: No further rationale is required.

4.6.6.1.3 Volume Control for Auditory Annunciations

[HS7075V] Auditory annunciation volume control shall be verified by test. The test shall be made with flight hardware and software. Auditory annunciations will be activated and the volume adjusted. Aural-annunciation volume control shall be verified by test. The test shall be made with flight hardware and software. Aural annunciations will be activated and the volume adjusted. Measurements shall be made, using a Type 1 integrating-averaging sound level meter, at expected head locations at the receiving station. The verification shall be considered successful when the test shows that the measured volume of aural annunciations, other than cautions and warnings, vary from 5 to 100% of maximum across the full range of the volume control.

Rationale: No further rationale is required.

4.6.6.1.4 Speech Intelligibility

[HS7076V] Auditory speech annunciations and communications intelligibility shall be verified by analysis and test. The analysis shall derive the nominal background noise spectrum for testing. The test shall be made with flight-configuration hardware and software using the methodology given in ANSI S3.2-2009. The verification shall be considered successful when the test and analysis indicates a 90% word identification level at the ear of the listener throughout the habitable volume.

Revision: E	Document No: CxP 70024
Release Date: 11/19/10	Page: 276 of 503
Title: Constellation Program Human-Systems Integration Requirements	

Rationale: 1) Prototype or qualification annunciation and communication system designs should be tested by analysis prior to manufacture of the actual annunciation and communication system. 2) Intermediate testing and analysis should be performed and reviewed by NASA to ensure confidence that compliance with this requirement will be met and to preclude late impacts to cost, schedule, and hardware.

4.6.6.1.5 Volume Control for Audio Communications

[HS7077V] Voice-channel volume control shall be verified by test. The test shall be made with flight hardware and software. Audio channels carrying voice will be activated and the volume adjusted while an operator speaks into the microphone at the sending station. Measurements shall be made, using a Type 1 integrating-averaging sound level meter, at expected head locations at the receiving station. The verification shall be considered successful when the test shows that the measured volume of each audio channel carrying voice communications varies 5 to 100% of maximum across the full range of the volume control.

Rationale: No further rationale is required.

4.6.6.2 Caution and Warning

4.6.6.2.1 Annunciation Hierarchy

[HS9029V] Off-nominal event classification shall be verified by demonstration. The demonstration shall be performed using flight-configuration software. The demonstration shall consist of the simulation of all contemplated off-nominal events and the classification of these events. The verification shall be considered successful when the demonstration shows that each off-nominal event is correctly assigned to one of the classifications.

Rationale: No further rationale is required.

4.6.6.2.2 Annunciation Prioritization

[HS9029AV] Prioritization of caution and warning annunciations shall be performed by demonstration. The demonstration shall be performed on a flight-configuration Caution and Warning System using all contemplated pairs of simultaneous off-nominal events. The verification shall be considered successful when the demonstration shows that the vehicle's caution and warning system prioritizes the caution and warnings annunciations according to Appendix K, table Alert Annunciation.

Rationale: No further rationale is required.

4.6.6.2.3 Visual and Auditory Annunciation

[HS9030V] Visual and auditory annunciations of emergency, warning, and caution events shall be verified by demonstration. The demonstration shall be performed using flight-configuration software and hardware and all contemplated emergency, warning,

Revision: E	Document No: CxP 70024
Release Date: 11/19/10	Page: 277 of 503
Title: Constellation Program Human-Systems Integration Requirements	

and caution events. The verification shall be considered successful when the demonstration shows that each emergency, warning, and caution event triggers the correct visual and auditory annunciations.

Rationale: No further rationale is required.

4.6.6.2.4 Distinctiveness of Annunciations

[HS9032V] Distinctiveness of alert annunciations and visual indications shall be verified by demonstration. The demonstration shall be performed on all nonspeech audio annunciations and visual indications using a flight-configuration system to annunciate the signals. Signal content will be compared to Appendix K, table Alert Annunciation. The verification shall be considered successful when the demonstration shows that all nonspeech audio annunciations and visual indications meet the Appendix K, table Alert Annunciation.

Rationale: No further rationale is required.

4.6.6.2.5 Loss of Annunciation Capability

[HS9032AV] Notification of system failure of visual or auditory annunciators shall be verified by test. The test shall be performed with flight-configuration software and hardware. The test shall run a scenario that simulates failures of the visual and auditory annunciator systems. The verification shall be considered successful when the test shows that the vehicle provides notification of either auditory or visual annunciator system failure.

Rationale: No further rationale is required.

4.6.7 Crew-System Interaction

4.6.7.1 Subsystem State Information

[HS7058V] Subsystem state information shall be verified by demonstration. The demonstration shall be performed using flight-configuration software and a list of representative subsystems from a task analysis. The demonstration shall involve requesting the display of subsystem states from the test data set. The verification shall be considered successful when the demonstration shows that all requested subsystem state information is displayed to the crew.

Rationale: No further rationale is required.

4.6.7.2 System Responsiveness for Discrete Inputs

[HS7058AV] Discrete feedback delay shall be verified by analysis or test. An analysis will show documentation of response time components (hardware/software and cognitive processing times) that combine to yield the final response time. The test will be performed with flight-configuration hardware and software and will involve timing the delay between a discrete user input and system feedback that the input was received.

Revision: E	Document No: CxP 70024
Release Date: 11/19/10	Page: 278 of 503
Title: Constellation Program Human-Systems Integration Requirements	

The verification shall be considered successful when the analysis or test indicates that the measured feedback delays are less than or equal to 0.1 second.

Rationale: No further rationale is required.

4.6.7.3 System Responsiveness for Continuous Inputs

[HS7058BV] Not Applicable

4.6.7.4 Request for Information

[HS7058CV] Not Applicable

4.6.7.5 Request for Critical Information

[HS7058DV] The response delay for critical displays shall be verified by test. The test shall be performed on a flight-configuration computer with a subset of mission critical displays. The test will involve requesting a mission critical display and timing the delay between the request and the presentation of the display. The verification shall be considered successful when the test shows that critical information is displayed within 1.0 second of the crew request.

Rationale: No further rationale is required.

4.6.7.6 Menu Update Time

[HS7058EV] Menu update rate shall be verified by test. The test shall be performed with flight-configuration hardware and software. The test shall consist of navigation through all menus while timing the delay between each menu selection and the appearance of the next level of the menu. The verification shall be considered successful when the test shows that measured time between menu selection and appearance of the next menu level is less than or equal to 0.5 second.

Rationale: No further rationale is required.

4.6.7.7 Command Feedback

[HS7055V] Command feedback delay shall be verified by test. The test will be performed using flight-configuration hardware and software and using a representative list of commands from a task analysis. The test will involve timing the delay between a command and feedback that the command is being processed, completed, or rejected. The verification shall be considered successful when the test shows that all delays are shown to be less than or equal to 2.0 seconds.

Rationale: No further rationale is required.

4.6.8 Electronic Procedures

4.6.8.1 Displaying Electronic Procedures System

[HS9025V] The electronic procedure system providing relevant vehicle information via displays shall be verified by demonstration. The demonstration shall be performed

Revision: E	Document No: CxP 70024
Release Date: 11/19/10	Page: 279 of 503
Title: Constellation Program Human-Systems Integration Requirements	

using flight-configuration hardware and software and a representative list of procedures, including those completed by crew and automation. The demonstration shall involve the simulation of tasks using the electronic procedures. The verification shall be considered successful when the demonstration shows that during any given step in the execution of the procedures, relevant vehicle information is displayed electronically.

Rationale: No further rationale is required.

4.6.8.2 Cueing Electronic Procedures System

[HS9025AV] The ability of the electronic procedure system to provide cues to required vehicle software commands shall be verified by demonstration. The demonstration shall be performed using flight-configuration hardware and software and a representative list of procedures, including those completed by crew and automation. The demonstration shall involve the simulation of tasks using the electronic procedures. The verification shall be considered successful when the demonstration shows that during the execution of the procedures, software commands required during the execution of the procedure are cued (made available).

Rationale: No further rationale is required.

4.6.8.3 Current Procedure Step

[HS9026V] The indication of the current procedure step shall be verified by demonstration. The demonstration shall be performed using flight-configuration hardware and software and a representative list of procedures, including those completed by crew and automation. The demonstration shall involve the simulation of the tasks using the electronic procedures. The verification shall be considered successful when the demonstration shows that the procedure display indicates the step in the procedure that is currently being executed.

Rationale: No further rationale is required.

4.6.8.4 Completed Procedure Steps

[HS9027V] The indication of the completed procedure step shall be verified by demonstration. The demonstration shall be performed using flight-configuration hardware and software and a representative list of procedures, including those completed by crew and automation. The demonstration shall involve the simulation of the tasks using the electronic procedures. The verification shall be considered successful when the demonstration shows that the procedure display indicates the step in the procedure that has been completed.

Rationale: No further rationale is required.

4.6.8.5 Crew Notification of Required Procedure Action

[HS9028V] Crew notifications of required procedural actions shall be verified by demonstration. The demonstration shall be performed using flight-configuration

Revision: E	Document No: CxP 70024
Release Date: 11/19/10	Page: 280 of 503
Title: Constellation Program Human-Systems Integration Requirements	

hardware and software and a representative list of procedures, including those completed by crew and automation. The demonstration shall involve the simulation of a task using the electronic procedures. The verification shall be considered successful when the demonstration shows that the crew was notified that attention to the procedure is required.

Rationale: No further rationale is required.

4.7 MAINTENANCE AND HOUSEKEEPING

4.7.1 Maintenance

4.7.1.1 Efficiency

4.7.1.1.1 ORU Changeout

[HS8001V] The maintenance and reconfiguration tasks shall be verified by analysis. The analysis shall consist of worksite analyses for each task. The verification shall be considered successful when all replaceable or reconfigurable equipment has been shown to be removable and replaceable or reconfigured under the task constraints.

Rationale: No further rationale is required.

4.7.1.1.2 Maintenance Time per Day

[HS8002V] The number of hours for preventive maintenance and housekeeping shall be verified by analysis. The analysis shall determine the total number of hours required for preventive maintenance and housekeeping for the mission duration and average the hours over the mission duration. The verification shall be considered successful when the analysis shows that all preventive maintenance and housekeeping can be accomplished for a mission while requiring no more than an average of two person-hours per day.

Rationale: No further rationale is required.

4.7.1.1.3 ORU Maintenance Time

[HS8003V] The number of hours for ORU maintenance shall be verified by analysis. The analysis shall consist of time studies for all ORU maintenance tasks. The verification shall be considered successful when the analysis shows that all ORUs have been assessed and can be maintained within 3 hours.

Rationale: No further rationale is required.

4.7.1.1.4 ORU Replacement Time/Maintenance

[HS8003V-Objective] Not Applicable.

4.7.1.1.5 Access Points

[HS8026V] Not Applicable

Revision: E	Document No: CxP 70024
Release Date: 11/19/10	Page: 281 of 503
Title: Constellation Program Human-Systems Integration Requirements	

4.7.1.2 Error-Proof Design

4.7.1.2.1 Physical Features

[HS8005V] The features to preclude improper mounting shall be verified by inspection. The inspection shall consist of a review of engineering drawings for hardware that is maintained or reconfigured and that is mounted. The verification shall be considered successful when the inspection shows that the mounted hardware has features to preclude improper mounting.

Rationale: No further rationale is required.

4.7.1.2.2 Labeling and Marking

[HS8006V] The visual indication for correct equipment mounting shall be verified by inspection. The verification shall be considered successful when the inspection of the vehicle Label Plan shows that a visual indication for correct equipment mounting has been provided in accordance with CxP 70152, Constellation Program Crew Interface Labeling Standard.

Rationale: No further rationale is required.

4.7.1.2.3 Interchangeability

[HS8007V] Hazard prevention for physically interchangeable ORUs that do not perform the same function shall be verified by inspection. The inspection shall consist of a review of the safety hazard reports for ORUs. The verification shall be considered successful when the inspection confirms that controls are in place to prevent ORUs that are functionally different from being physically interchanged.

Rationale: No further rationale is required.

4.7.1.2.4 Connectors

[HS8008V] Physical features to preclude mismatching and misalignment shall be by inspection, analysis, or demonstration. For the connector physical features, a demonstration consisting of mating and demating shall be performed for each connector type. For an integrated configuration, inspection and analysis shall be performed. The inspection shall consist of a review of the drawings for connector part numbers. An analysis shall assess the arrangement of the different types of connectors and the cable lengths.

The verification for the connector physical features shall be considered successful when the demonstration shows that the different types of connectors cannot be mismatched and that misalignment is prevented within the connector type. The verification for the integrated configuration shall be considered successful with the inspection and analysis show that connectors cannot be mismatched within connector groupings.

Rationale: No further rationale is required.

Revision: E	Document No: CxP 70024
Release Date: 11/19/10	Page: 282 of 503
Title: Constellation Program Human-Systems Integration Requirements	

4.7.1.2.5 Visual Indication

[HS8045V] Orientation cues on connectors shall be verified by inspection. The verification shall be considered successful when the inspection of the vehicle Label Plan shows that there is an orientation cue that can be used prior to mating in accordance with CxP 70152, Constellation Program Crew Interface Labeling Standard.

Rationale: No further rationale is required.

4.7.1.2.6 Connector Mating Indication

[HS8046V] Completion of connector mating shall be verified by demonstration. The demonstration shall consist of mating and demating connector types. The verification shall be considered successful when the demonstration shows that a positive indication is provided when the mating is completed.

Rationale: No further rationale is required.

4.7.1.2.7 Unique Identification Labeling

[HS8047V] Identification labeling shall be verified by inspection. The verification shall be considered successful when the inspection of the vehicle Label Plan shows that all equipment has a uniquely identifying label in accordance with CxP 70152, Constellation Program Crew Interface Labeling Standard.

Rationale: No further rationale is required.

4.7.1.3 Access

4.7.1.3.1 Disturbance of Equipment

4.7.1.3.1.1 Disturbance of Equipment

[HS8053V] Not applicable.

4.7.1.3.2 Visual Access

4.7.1.3.2.1 Visual Access

[HS8009V] The visual access shall be verified by analysis. The analysis shall consist of worksite analyses that examine planned maintenance tasks and show the task interfaces to be within visual access of the maintainer. The verification shall be considered successful when analysis shows that the design provides visual access for planned maintenance tasks except blind-mate connector mating.

Rationale: No further rationale is required.

Revision: E	Document No: CxP 70024
Release Date: 11/19/10	Page: 283 of 503
Title: Constellation Program Human-Systems Integration Requirements	

4.7.1.3.3 Physical Access

4.7.1.3.3.1 Physical Access

[HS8010V] The work envelope for maintenance activities shall be verified by analysis. The analysis shall consist of worksite analyses for all interfaces that must be accessed to perform maintenance on each replaceable equipment item. The verification shall be considered successful when the analysis shows that all maintenance tasks can be shown to be within the access of the anthropometric range of flight crews, from work locations appropriate to the tasks, and under the environmental constraints (e.g., protective garment) of the tasks.

Rationale: No further rationale is required.

4.7.1.3.4 Maintenance Hazard

4.7.1.3.4.1 Maintenance Hazard

[HS8015V] Access to ORUs shall be verified by inspection. The inspection shall consist of a review of drawings and models that show the ORU location and all surrounding equipment. The verification shall be considered successful when access to ORUs can be accomplished without impacting other systems.

Rationale: No further rationale is required.

4.7.1.3.5 Crew Control of Power

4.7.1.3.5.1 Crew Control of Power

[HS8055V] Crew interruption of electrical power and confirmation of energized circuits shall be verified by analysis and demonstration. The analysis shall identify locations that could expose IVA crewmembers to voltages in excess of 32V. The demonstration shall be in the flight vehicle and include a subject demonstrating the ability to interrupt electrical power at the locations identified in the analysis. The analysis and demonstration shall be considered successful when it is shown that the crewmember can interrupt electrical power and confirm the de-energized status of the circuit that could expose crewmembers to voltages in excess of 32V.

Rationale: No further rationale is required.

4.7.1.4 Failure Notification

4.7.1.4.1 Failure Notification

[HS8016V] Component failure alert shall be verified by demonstration. The demonstration shall include simulating out-of-tolerance operation of equipment. The verification shall be considered successful when an alert is detected upon the system's receipt of out-of-tolerance limits.

Rationale: No further rationale is required.

Revision: E	Document No: CxP 70024
Release Date: 11/19/10	Page: 284 of 503
Title: Constellation Program Human-Systems Integration Requirements	

4.7.1.5 Circuit Protection

4.7.1.5.1 No Fuses for Dynamic Flight Phases

[HS8017V] Circuit protection shall be verified by analysis. An analysis shall determine which circuits may reset during dynamic phases of flight. The verification shall be considered successful when the analysis shows that fuses are not required to protect circuits during dynamic phases of flight.

Rationale: No further rationale is required.

4.7.1.5.2 Circuit Breakers Instead of Fuses

[HS8018V] Not Applicable

4.7.1.5.3 Replacement Without Tools

[HS8020V] The removal and replacement of fuses shall be verified by inspection. The inspection shall consist of review of the engineering drawings for all equipment that contain in-flight replaceable fuses. The verification shall be considered successful when the inspection shows that fuses can be removed and replaced without a tool.

Rationale: No further rationale is required.

4.7.1.5.4 Replacement Without Component Removal

[HS8021V] The removal and replacement of fuses in-flight shall be verified by inspection. The inspection shall consist of a review of drawings or models for equipment with in-flight maintenance that contain fuses. Verification shall be considered successful when the inspection shows that each fuse can be removed and replaced without the removal of other components.

Rationale: No further rationale is required.

4.7.1.5.5 Circuit Breaker Resetting

[HS8022V] The access to reset circuit breakers by a restrained suited crewmember shall be verified by analysis and inspection. An analysis shall determine the circuit breakers the crewmembers need to reach during ascent and entry. The inspection shall consist of a review of drawings or models for the integrated circuit breakers. The verification shall be considered successful when the analysis and inspection show that the crewmember can reach each identified circuit breaker during dynamic flight phases without removing or opening a panel.

Rationale: No further rationale is required.

4.7.1.5.6 Trip Indication

[HS8023V] Indication of an open circuit shall be verified by inspection. The inspection shall consist of a review of the engineering drawings for hardware that uses fuses and

Revision: E	Document No: CxP 70024
Release Date: 11/19/10	Page: 285 of 503
Title: Constellation Program Human-Systems Integration Requirements	

circuit breakers. The verification shall be considered successful when the inspection shows that feedback is provided when the circuit is open.

Rationale: No further rationale is required.

4.7.1.6 Electrostatic Discharge (ESD)

4.7.1.6.1 Electrostatic Discharge

[HS8024V] The labeling of “sensitive to electrostatic discharge” shall be verified by analysis and inspection. The analysis shall determine which equipment is susceptible to electrostatic discharge damage during operation or planned in-flight maintenance. The inspection shall consist of reviewing the vehicle Label Plan for the identified hardware. The verification shall be considered successful when the inspection of the vehicle Label Plan shows that the hardware drawings illustrate the locations for sensitive to electrostatic discharge labels for the hardware identified in the analysis.

Rationale: No further rationale is required.

4.7.1.7 Fasteners

4.7.1.7.1 Fasteners Heads

[HS8029V] Anti-cam-out heads shall be verified by analysis and inspection. The analysis shall identify on-orbit, tool-operated fasteners. The inspection shall consist of a review of the engineering drawings. The verification shall be considered successful when the analysis and inspection show that on-orbit, tool-operated fasteners have a self-centering anti-cam-out head.

Rationale: No further rationale is required.

4.7.1.7.2 Fasteners Number and Variety

[HS8030V] Not Applicable

4.7.1.7.3 Captive Fasteners

[HS8031V] The use of captive fasteners shall be verified by inspection. The inspection shall consist of a review of the drawings that contain fasteners that will be used in-flight. The verification shall be considered successful when the inspection shows that each fastener to be actuated during in-flight maintenance tasks is captive.

Rationale: No further rationale is required.

4.7.1.8 Fluids

4.7.1.8.1 Equipment Isolation

[HS8032V] Fluid isolation features shall be verified by inspection. The inspection shall consist of a review of the engineering drawings for the components and ORUs that contain fluid and require maintenance. The verification shall be considered successful when the inspection shows that the components and ORUs have fluid isolation features.

Revision: E	Document No: CxP 70024
Release Date: 11/19/10	Page: 286 of 503
Title: Constellation Program Human-Systems Integration Requirements	

Rationale: No further rationale is required.

4.7.1.8.2 Hazardous Levels of Fluid Leakage

[HS8034V] Fluid leakage shall be verified by test. The test shall measure the amount of fluids released while connecting and disconnecting a fluid interface. The verification shall be considered successful when the test shows that amount of fluid released does not exceed levels described in JSC20584, Spacecraft Maximum Allowable Concentrations (SMAC) for Airborne Contaminants.

Rationale: No further rationale is required.

4.7.1.9 Tools

4.7.1.9.1 Common Toolset

[HS8037V] Not applicable.

4.7.1.9.2 Tool Clearance

[HS8052V] Tool clearance shall be verified by analysis. Tool interfaces shall be assessed, and the allowance for the specified tool shall be analyzed through the entire tool use envelope. Verification shall be considered successful when all tool interfaces have been shown to be in compliance.

Rationale: No further rationale is required.

4.7.1.9.3 Tool Usage

[HS8054V] Tool usage shall be verified by analysis and test. The analysis shall be performed to determine if crewmembers can operate all tools per Appendix B, table Unsuit Strength Data. The test shall consist of a set of tasks to test the operation and structural limit of the components. The analysis and test results shall be verified against Appendix B, table Unsuit Strength Data by means of population analytical methods. The verification shall be considered successful when the analysis and test show that the strength measurements have been met and that the crewmember can physically interact and operate all tools for the on-orbit maintenance and reconfiguration tasks.

Rationale: No further rationale is required.

4.7.2 Housekeeping

4.7.2.1 Design for Cleanliness

4.7.2.1.1 Microbial Contamination

[HS8041V] Microbial contamination shall be verified by test. The test shall collect samples on the interior surfaces. The verification shall be considered successful when the test shows that all sampled interior surfaces show fewer than 500 CFU per 100 cm² of microbial contamination.

Rationale: No further rationale is required.

Revision: E	Document No: CxP 70024
Release Date: 11/19/10	Page: 287 of 503
Title: Constellation Program Human-Systems Integration Requirements	

4.7.2.1.2 Fungal Contamination

[HS8042V] Fungal contamination shall be verified by test. The test shall be conducted prelaunch. The test shall collect samples on the interior surfaces. The verification shall be considered successful when the test shows that all sampled interior surfaces show fewer than 10 CFU per 100 cm² of fungal contamination.

Rationale: No further rationale is required.

4.7.2.1.3 Condensation Prevention on Interior Surfaces

[HS8051V] The condensation persistence on surfaces shall be verified by analysis. The analysis shall consider crew induced metabolic loads in Appendix E, table Crew Induced Metabolic Loads for a Standard Mission Day With Exercise. The analysis shall include a thermal analysis to determine expected water on internal surfaces. The verification shall be considered successful when the analysis shows that condensation persistence is limited to 1 hour a day on surfaces within the internal volume during the mission.

Rationale: No further rationale is required.

4.7.2.2 Replacement of Air Filters

4.7.2.2.1 Replacement of Air Filters

[HS8043V] Not Applicable.

4.8 INFORMATION MANAGEMENT

4.8.1 Crew Operability

4.8.1.1 Crew Operability

[HS9021V] The capability for the crew to perform information management functions shall be verified by analysis and demonstration. The analysis shall determine the methods and tools for the crew to perform information management functions. The analysis shall show what information management functions are required to be available to the crew. The demonstration shall use flight-configuration software displays that show that each information management function, determined by a task analysis, can be performed on-board the vehicle. The verification shall be considered successful when information management functions defined by the analysis are shown to be available to the crew.

Rationale: No further rationale is required.

4.8.2 Data Available

4.8.2.1 Data Rate

[HS9014V] Not applicable.

Revision: E	Document No: CxP 70024
Release Date: 11/19/10	Page: 288 of 503
Title: Constellation Program Human-Systems Integration Requirements	

4.8.2.2 Data Fidelity

[HS9040V] The data fidelity requirement shall be verified by analysis and test. The analysis shall determine the data fidelity required for a given task. The test shall be performed on a flight-configuration workstation using flight-configuration software loads. The data fidelity required for each task will be assessed. The verification shall be considered successful when the test shows that the data have been acquired with the fidelity specified by the analysis.

Rationale: The data necessary for proper performance of all crew and ground personnel tasks for a given mission shall be determined by a task analysis.

4.8.3 Data Distribution

4.8.3.1 Locations of Data

[HS9018V] The workstation data availability shall be verified by demonstration. A task analysis shall determine what tasks will be performed on a given workstation and the data required to perform those tasks. The demonstration shall be performed on flight-configuration workstations and software. The verification shall be considered successful when the demonstration shows that all data required at a particular workstation are available at that workstation.

Rationale: The data necessary for proper performance of all crew and Mission Systems personnel tasks for a given workstation shall be determined by a task analysis.

4.8.3.2 Wired Network

[HS9019V] The vehicle's wired data distribution system shall be verified by analysis and demonstration. The analysis shall identify the required wired locations including a review of operational criticality. The demonstration shall be performed using simulated data streams with flight-configuration software loads and flight-configuration hardware. The verification shall be considered successful when the demonstration shows that vehicle data can be distributed through the wired data network to the locations defined by the analysis.

Rationale: The analysis will determine what data will go to what location.

4.8.3.3 Wireless Network

[HS9020V] The vehicle's wireless data distribution system shall be verified by analysis and demonstration. The analysis shall identify the required wireless locations including a review of operational criticality. The demonstration shall be performed using simulated data streams with flight-configuration software loads and flight-configuration hardware. The verification shall be considered successful when the demonstration shows that vehicle data can be distributed through the wireless data network to the locations defined by the analysis.

Revision: E	Document No: CxP 70024
Release Date: 11/19/10	Page: 289 of 503
Title: Constellation Program Human-Systems Integration Requirements	

Rationale: The analysis will determine what data will go to what location.

4.8.4 Data Backup

4.8.4.1 Manual Information Capture and Transfer

[HS9042AV] The ability to provide a method for the crew to capture and transfer information from any display in a format that provides mobility and the ability to annotate shall be verified by demonstration. The demonstration shall consist of a sample set of information being captured and transferred using flight-configuration hardware and flight software loads. The verification shall be considered successful when the demonstration produces the desired information that can be mobile and have the ability to annotate.

Rationale: No further rationale is required.

4.9 GROUND MAINTENANCE AND ASSEMBLY

4.9.1 Ground Anthropometry, Biomechanics, and Strength

4.9.1.1 Ground Anthropometry, Biomechanics, and Strength

[HS10008V] The provision of worksites that are sized for the anthropometric range of ground crews shall be verified by analysis. The analysis shall consist of worksite analyses for each assembly and ground maintenance task, as defined by the Vehicle Assembly and Ground Maintenance Task Analysis. The verification shall be considered successful when the analysis shows that each worksite is sized for the anthropometric range of stature for the 5th to 95th percentiles of the ground crew population for anthropometric dimensions that were defined based on task analysis.

Rationale: No further rationale is required.

4.9.2 Ground Natural and Induced Environments

4.9.3 Ground Safety

4.9.3.1 Ventilation Openings

[HS10027V] Protection of ventilation openings from inadvertent insertion of foreign objects shall be verified by analysis and inspection. The task analysis shall identify assembly and maintenance worksites. Worksite analysis shall show the reach envelope of crews during tasks, and an inspection of drawings shall be used to assure that openings within the reach envelope are protected from inadvertent insertion of tools or body parts. The verification shall be considered successful when the inspection shows that openings identified in the analysis are protected from insertion of foreign objects.

Rationale: No further rationale is required.

4.9.3.2 Ground Processing Hardware Access

[HS10030V] Protection from sharp edges shall be verified by analysis and inspection. The task analysis shall identify the flight system equipment with which the ground crew

Revision: E	Document No: CxP 70024
Release Date: 11/19/10	Page: 290 of 503
Title: Constellation Program Human-Systems Integration Requirements	

will interact with during assembly and maintenance tasks, as identified in the Vehicle Assembly and Maintenance Task Analysis. The inspection shall be a review of drawings of the flight system equipment identified in the task analysis. The verification shall be considered successful when the analysis and inspection show that the identified areas have protection from sharp edges.

Rationale: No further rationale is required.

4.9.3.3 Hazards Labeling

[HS10033V] Hazard labeling shall be verified by inspection. The inspection shall identify the list of equipment that is susceptible to damage or constitutes a hazard to the ground crew. This list will include the type of hazard (ESD, chemical, pressurized fluid, etc.). The verification shall be considered successful when the inspection shows that all items on the list have been labeled with hazard information

Rationale: No further rationale is required.

4.9.4 Ground Architecture

4.9.4.1 Work Station Layout Interference

[HS10047V] Not Applicable.

4.9.4.2 Work Station Layout Sequential Operations

[HS10048V] Not Applicable.

4.9.5 Ground Crew Functions

4.9.6 Ground Crew Interfaces

4.9.6.1 Labeling

[HS10039V] Labels for ground crew interface controls and indicators shall be verified by inspection and analysis. The task analysis shall define those tasks for which there are controls or indicators. Inspection of drawings shall determine if labels have been incorporated into the design for those tasks. The verification shall be considered successful when the inspection shows that the controls and indicators identified in the analysis have been labeled.

Rationale: No further rationale is required.

4.9.6.2 Ground Labeling - Non-interference with Flight Labels

[HS10055V] Noninterference of ground assembly labels with crew interface labeling will be verified by inspection and analysis. The inspection shall be a review of drawings for hardware that contains crew interface labels and ground labels. The analysis shall assess the use of crew labeling and determine if ground labeling is nearby. The verification shall be considered successful when the inspection and analysis show that

Revision: E	Document No: CxP 70024
Release Date: 11/19/10	Page: 291 of 503
Title: Constellation Program Human-Systems Integration Requirements	

the ground labels do not interfere with the crew interface flight labeling, visually or operationally.

Rationale: No further rationale is required.

4.9.6.3 Consistent Crew Interfaces

[HS10050V] Not applicable.

4.9.6.4 Legibility

[HS10051V] Legibility of labels and displays shall be verified by analysis. The analysis shall determine which labels and displays the ground crew will use and the associated task conditions. The verification shall be considered successful when the analysis shows that the labels and displays are legible under the task conditions.

Rationale: The intent of the requirement is to ensure that the information can be read or is otherwise legible under the task conditions. It is assumed that this will include appropriate placement and orientation of the information.

4.9.6.5 Written Text

[HS10052V] The American English language requirement shall be verified by inspection. The inspection shall be performed on items containing text. The verification shall be considered successful when the inspection shows that all text is found to be written in the American English language based on Webster's New World Dictionary of American English.

Rationale: No further rationale is required.

4.9.6.6 Use of Color

[HS10053V] Not applicable.

4.9.6.7 Work Envelope Volumes

[HS10002V] Assembly and maintenance work envelope volumes shall be verified by analysis. The analysis shall consist of task and worksite analysis. The Vehicle Assembly Task Analysis and the Vehicle Maintenance Task Analysis shall be applied to determine task assumptions and constraints (e.g., SCAPE suit), and the worksite analysis shall account for constraints. Analysis shall account for the anthropometric range as applicable, the task, and the environmental constraints. The verification shall be considered successful when the analysis shows that the tasks have the needed work envelope volumes.

Rationale: No further rationale is required.

4.9.6.8 Reach Envelope Volumes

[HS10004V] Reach envelope volumes for assembly and maintenance tasks shall be verified by analysis. The analysis shall examine all assembly tasks identified in the

Revision: E	Document No: CxP 70024
Release Date: 11/19/10	Page: 292 of 503
Title: Constellation Program Human-Systems Integration Requirements	

Vehicle Assembly Task Analysis. The task analysis shall determine task assumptions and constraints (e.g., SCAPE suit), and worksite analysis shall account for constraints per FAA-HF-STD-001, Sections 14.1 through 14.5 and NASA-STD-3000 Section 3.3.3. The analysis shall also include a worksite analysis. This analysis shall account for the anthropometric range applicable, the task, and the environmental constraints. The verification shall be considered successful when the analysis shows that the reach envelope volumes needed for corrective and preventive maintenance tasks have been provided.

Rationale: No further rationale is required.

4.9.6.9 Ground Crew Visual Access

[HS10006V] Visual access shall be verified by analysis. The analysis shall examine assembly and maintenance tasks, as identified in the Vehicle Assembly Task Analysis and the Vehicle Maintenance Task Analysis, respectively. A worksite analysis shall be performed using CAD models and human models that display field of view of the ground crew. The verification shall be considered successful when the analysis shows that the ground crew has the visual access to perform the tasks associated with vehicle maintenance.

Rationale: No further rationale is required.

4.9.7 Launch Site Processing and Ground Maintenance

4.9.7.1 Line Replaceable Units (LRUs)

4.9.7.1.1 LRU Installation

[HS10012V] Features to prevent incorrect LRU installation shall be verified by inspection. The inspection shall examine the LRU drawings and their interfaces to the vehicle for features that preclude incorrect installation. The verification shall be considered successful when the inspection shows that all LRUs have features to preclude incorrect installation.

Rationale: No further rationale is required.

4.9.7.1.2 LRU Mounting/Alignment Labels/Codes

[HS10013V] Identification for proper mounting and alignment of LRUs shall be verified by inspection. The inspection shall examine LRU drawings and their interfaces to the vehicle for labels or other coding that indicates proper installation. The verification shall be considered successful when the inspection shows that all LRUs and their interfaces have a visual indication of proper mounting and alignment.

Rationale: No further rationale is required.

Revision: E	Document No: CxP 70024
Release Date: 11/19/10	Page: 293 of 503
Title: Constellation Program Human-Systems Integration Requirements	

4.9.7.1.3 LRU Interchangeability

[HS10014V] Noninterchangeability of LRUs shall be verified by analysis. The function of LRUs shall be determined by inspection of documentation, drawings, and diagrams. Drawings of LRUs and their interfaces shall be examined for installation and connection design. Analysis shall compare those LRUs that are determined to be functionally distinct to ensure that they cannot be installed in place of any other distinct unit. The verification shall be considered successful when the analysis shows that LRUs are functionally distinct replaceable units that cannot be installed in the wrong location.

Rationale: No further rationale is required.

4.9.7.1.4 LRU Tracking Labels

[HS10031V] The labeling for logistics tracking shall be verified by inspection. The inspection shall review the drawings of LRUs with which the ground crew shall interact based on the assembly and maintenance tasks, as identified in the Vehicle Assembly and Maintenance Task Analysis. The verification shall be considered successful when inspection shows that the LRUs have logistics tracking labels.

Rationale: No further rationale is required.

4.9.7.1.5 LRU Labeling

[HS10032V] LRU and flight component labeling shall be verified by analysis and inspection. The task analysis shall identify the LRUs and flight components with which the ground crew will interact during assembly and maintenance tasks, as identified in the Vehicle Assembly and Maintenance Critical Task Analysis. The inspection shall be a review of the LRU and flight component drawings based on the task analysis. The verification shall be considered successful when the analysis and inspection shows that the hardware identified in the task analysis is labeled with identification information within the view of the ground crew.

Rationale: No further rationale is required.

4.9.7.1.6 LRU Protrusions

[HS10042V] LRU handling provisions shall be verified by inspection. The inspection shall consist of a review of engineering drawings and handling procedures for LRU handling provisions. The verification shall be considered successful when the inspection shows that all LRUs have handling provisions for ground crews.

Rationale: No further rationale is required.

4.9.7.1.7 LRU Weight Limit

[HS10045V] The safe lifting weight for one ground person without Ground Support Equipment shall be verified by analysis. The analysis shall consider the frequency, height, coupling, and other multipliers for the installation per Appendix L from the point of lifting to the point of installation. The verification shall be considered successful when

Revision: E	Document No: CxP 70024
Release Date: 11/19/10	Page: 294 of 503
Title: Constellation Program Human-Systems Integration Requirements	

the analysis shows that the identified LRUs do not exceed the NIOSH recommended weight limit for one ground crewperson.

Rationale: No further rationale is required.

4.9.7.1.8 LRU Removal without Component Removal

[HS10054V] Not applicable.

4.9.7.1.9 LRU Removal and Replacement

[HS8004V] Not Applicable.

4.9.7.2 Connectors

4.9.7.2.1 Connector Mismatching

[HS10015V] Prevention for mismatching connectors within the same physical location shall be verified by analysis and inspection. The analysis shall identify which connector plugs might possibly be mated to which jacks and the cable lengths associated with each connector. The inspection shall review all drawings for the connector assemblies identified by the analysis that could possibly be mated. The verification shall be considered successful when the analysis and inspection show that connectors within the same physical location cannot be physically mismatched.

Rationale: No further rationale is required.

4.9.7.2.2 Connector Mating Labels

[HS10017V] Connector mating labels shall be verified by inspection. The inspection shall consist of a review of engineering drawings that contain the connectors to be mated during launch site processing. The verification shall be considered successful when the inspection shows that the connectors within the same physical location have labels that define correct mating.

Rationale: No further rationale is required.

4.9.7.3 Captive Fasteners

4.9.7.3.1 Captive Fasteners

[HS10026V] Not applicable.

4.9.7.4 Tools

4.9.7.4.1 Toolset

[HS10028V] Tools used for assembly and maintenance shall be verified by analysis. The Vehicle Assembly Task Analysis and the Vehicle Maintenance Task Analysis will identify those tasks that require tools and the tool for each respective task. The analysis will compare the identified tools with the table Launch Site Task Tool List

Revision: E	Document No: CxP 70024
Release Date: 11/19/10	Page: 295 of 503
Title: Constellation Program Human-Systems Integration Requirements	

<TBD-70024-050>. The verification shall be considered successful when the analysis shows that all tools used for maintenance and assembly are on the tool list.

Rationale: No further rationale is required.

4.9.7.4.2 Tool Clearances

[HS10024V] Tool clearances for assembly, launch site processing, and corrective and preventive maintenance at the launch site shall be verified by analysis. The Vehicle Assembly Task Analysis and the Vehicle Maintenance Task Analysis will identify those tasks that require tools and the tool for each respective task. The verification shall be considered successful when the analysis shows that all tool interfaces have the clearance needed for installation and actuation.

Rationale: No further rationale is required.

4.9.7.5 Fuse/Circuit Indication

4.9.7.5.1 Fuse/Circuit Indication

[HS10010V] Indication of an open circuit shall be by inspection. Drawings shall be inspected for devices that contain a fuse or circuit breaker. The verification shall be considered successful when the inspection shows that each drawing identifying circuit protection devices has a callout that specifies the parts that are designed to provide a positive indication of an open circuit.

Rationale: No further rationale is required.

4.9.7.6 Access

4.9.7.6.1 Maintainability Without Deintegration

[HS10001V] Maintainability without deintegration or demating of certified interfaces shall be verified by analysis and demonstration. The analysis shall examine preventive ground maintenance tasks, as identified in the Vehicle Maintenance Task Analysis. Worksite analysis for each task shall evaluate the need to deintegrate or demate systems for each of the defined tasks. A demonstration of the maintenance task shall be performed only for tasks require two or more personnel. The verification shall be considered successful when the analysis and demonstration show that maintenance tasks can be completed without deintegration or demating of previously tested and certified interfaces.

Rationale: The Vehicle Maintenance Task Analysis is a complete listing of all tasks associated with vehicle maintenance (includes, e.g., bolt insertion, bolt torquing, connector mating, etc.). This task analysis becomes a deliverable product that is the basis of procedures development. Worksite analysis is typically a CAD-based assessment of task feasibility, using human models. Simple measurement may be accomplished by drawing inspection.

Revision: E	Document No: CxP 70024
Release Date: 11/19/10	Page: 296 of 503
Title: Constellation Program Human-Systems Integration Requirements	

4.9.7.6.2 Maintainability without Disabling Subsystems

[HS10009V] Not applicable.

4.9.7.6.3 Appropriate Clothing and Equipment

[HS10011V] Accommodation for ground crews wearing protective clothing and equipment shall be verified by analysis. The analysis shall consist of worksite analyses for each assembly task, as defined by the Vehicle Assembly Task Analysis. Task analysis shall identify those tasks that require protective equipment for assembly. Worksite analysis shall assess task feasibility under the constraints of protective equipment. The verification shall be considered successful when the analysis shows that tasks that require protective clothing and/or equipment can be accommodated within the worksite.

Rationale: No further rationale is required.

4.9.7.6.4 Inspection Access

[HS10025V] Accessibility for component inspection during launch site processing shall be verified by analysis. The analysis shall identify components required to be inspected during launch site processing. An accessibility analysis shall be completed for each identified component. The verification shall be considered successful when the analysis shows that each component requiring inspection can be accessed.

Rationale: No further rationale is required.

4.9.7.6.5 Cable Access

[HS8011V] Cable accessibility shall be verified by analysis. The maintenance and inspection task list will identify those cables that require inspection. The analysis shall consist of an assessment of the visibility and reach access to cables for ground operations. The verification shall be considered successful when the analysis shows that the ground crew can gain access to all cables.

Rationale: No further rationale is required.

4.9.7.6.6 External Service Points

[HS8013V] The external service point locations shall be verified by inspection. The inspection shall consist of a review of drawings or models of the external service points and their location in relation to the service structure. The verification shall be considered successful when the inspection shows that all service points are within 60 degrees radially of the plane between the vehicle and service structure.

Rationale: The Orion and Ares I project meet the intent of this requirement via interface requirements in CxP 70052-02 CxP Ares I-to-GS IRD Vol 2 and CxP 70028 CxP Orion-to-Ground Systems IRD.

Revision: E	Document No: CxP 70024
Release Date: 11/19/10	Page: 297 of 503
Title: Constellation Program Human-Systems Integration Requirements	

4.9.7.6.7 Visual Line of Sight

[HS8048V] Not applicable.

4.9.7.7 Damage/Hazard Controls

4.9.7.7.1 Maintenance Without Damage

[HS10019V] Protection for components during scheduled or preventive maintenance shall be verified by analysis. The task analysis shall identify all scheduled or preventive maintenance tasks. The analysis shall examine drawings and models for each area and the surrounding equipment. The verification shall be considered successful when the analysis shows that all maintenance activities associated with one component does not result in damage of other in-place and certified components.

Rationale: No further rationale is required.

4.9.7.7.2 Fluid Management

[HS10020V] Isolating, draining, or venting of pressurized fluids during launch site processing and ground maintenance shall be verified by analysis. The Vehicle Assembly Task Analysis and the Vehicle Maintenance Task Analysis shall identify those systems that contain pressurized fluids. The verification shall be considered successful when the analysis shows that all subsystems with pressured fluids that require ground crew intervention have isolation features or provisions for draining or venting.

Rationale: No further rationale is required.

4.9.7.7.3 Fluid Spillage Control

[HS10021V] Controls for fluid release during launch site processing shall be verified by inspection. The inspection shall review drawings and other documentation for controls that provide methods of limiting ground crew exposure to fluid spillage. The verification shall be considered successful when the inspection shows that design for assembly and maintenance tasks includes controls for spillage and fluid release.

Rationale: No further rationale is required.

4.9.7.7.4 System Safing Controls

[HS10022V] Controls to safe the system prior to maintenance shall be verified by inspection. The inspection drawings and other documentation shall identify controls that provide methods of system safing. The verification shall be considered successful when the inspection shows that controls for safing the system have been provided for assembly and maintenance tasks.

Rationale: No further rationale is required.

4.9.7.7.5 Equipment Protection

[HS10023V] Not applicable.

Revision: E	Document No: CxP 70024
Release Date: 11/19/10	Page: 298 of 503
Title: Constellation Program Human-Systems Integration Requirements	

4.9.7.7.6 Safety Displays

[HS10029V] Display placement for tasks that could result in a hazard shall be verified by analysis. Task analysis shall determine which tasks require operator views of displays for successful task completion. Worksite analysis shall evaluate the position of the display while the task is being performed. The verification shall be considered successful when the analysis shows that all tasks requiring visual access to displays are within the field of view of the personnel performing the task.

Rationale: No further rationale is required.

4.9.7.7.7 Protrusion Label/Support

[HS10043V] Protrusions that could be used as handles, steps, or handrails shall be verified by analysis. The analysis shall determine which protrusions could be inadvertently used for handles, steps, handrails or mobility aids. The verification shall be considered successful when the analysis shows that the identified protrusions accessible to the ground and flight crews can support the weight of personnel or that they are clearly labeled as a Keep Out Zone.

Rationale: No further rationale is required.

4.9.8 Ground Information Management

4.10 EXTRAVEHICULAR ACTIVITY (EVA)

4.10.1 Suit Atmosphere

4.10.1.1 Suit Pressure

4.10.1.1.1 Suit Pressure Set-Point Selection

[HS11000V] Discrete test points for suit pressure shall be verified by demonstration and test. The demonstration shall be an evaluation by pressurized suited crewmembers selecting each of the discrete pressure set-points. The test shall involve measurements of total suit pressure taken at each set-point. The verification shall be considered successful when the demonstration shows that the crewmember can select each set point as documented in a crew consensus report and the test measurements confirm the required suit pressure at each set-point.

Rationale: No further rationale is required.

4.10.1.1.2 Maintain Pressure Set-Point

[HS11019V] Maintaining the selected pressure shall be verified by test and inspection. The test shall consist of actual or simulated metabolic loads while each discrete total pressure value is selected. Continuous measurements of the system's pressure shall be taken for a specified period of time at each discrete pressure set-point. The inspection of test results shall consist of a review of pressure fluctuation levels. The verification shall be considered successful when the test and the inspection of the test

Revision: E	Document No: CxP 70024
Release Date: 11/19/10	Page: 299 of 503
Title: Constellation Program Human-Systems Integration Requirements	

results show that the system limits total pressure fluctuations to within +/-0.05 psig of the established set-point.

Rationale: No further rationale is required.

4.10.1.1.3 Suit Pressure Pause

[HS11001V] The capability of the system to allow the suited crew to stop and restart suit pressurization shall be verified by test. The test shall consist of pressurized suited crewmembers stopping and restarting the pressurization process with suit pressure measurements taken continuously throughout the test. Verification shall be considered successful when the test data confirm that suit pressurization started and stopped in response to inputs from the crewmembers, and subjective evaluation by the crewmembers, as documented in a crew consensus report, confirms the ability of the crew to initiate the start and stop of pressurization while in a pressurized suit.

Rationale: No further rationale is required.

4.10.1.2 Thermal Environment for the Suited Crewmember

4.10.1.2.1 Control of Heat Stored by Crewmembers during EVA and Pre-launch Operations

[HS11002V] Maintaining the energy stored by the crew in a pressurized suit shall be verified by analysis. The analysis shall use performance data and data from acceptance/qualification testing for the EVA suit system, along with worst-case anticipated metabolic loading. The verification shall be considered successful when the analysis shows that during EVA operations the suit system can maintain ΔQ stored within 3.0 kJ/kg/hr (1.3 BTU/lb) $> \Delta Q$ stored $> -1.9 \text{ kJ/kg/hr}$ (-0.8 BTU/lb).

Rationale: No further rationale is required.

4.10.1.2.2 Crew Accessibility to Suit Temperature Controls

[HS11022V] The crew adjustment of their suit temperature set point shall be verified by analysis and demonstration. The analysis shall determine what suited tasks are to be performed during a nominal operation while restrained and unrestrained. The demonstration shall consist of a single suited crewmember adjusting the temperature during operation of an integrated vehicle system. The verification shall be considered successful when the analysis and demonstration show that the temperature can be adjusted by a single suited crewmember, including times when the crew is restrained.

Rationale: No further rationale is required.

Revision: E	Document No: CxP 70024
Release Date: 11/19/10	Page: 300 of 503
Title: Constellation Program Human-Systems Integration Requirements	

4.10.1.3 Deleted

4.10.1.4 Radiation Monitoring for Suited Crewmembers

4.10.1.4.1 Suited Radiation Dose Equivalent Monitoring

[HS11023V] Dose equivalent monitoring shall be verified by test. The test shall use one flight equivalent instrument to verify the requirement. The test shall be an exposure of the flight equivalent instrument to radiation sources. The test shall use accelerator sources of charged particles with $Z=1$ with energies of 50 MeV, 100 MeV, and 200 MeV. The test shall use Cesium-137 or Cobalt-60 photon source. Each radiation source shall deliver a total dose equivalent of 100 mSv for each of the dose equivalent ranges of: 1 mSv per hour to 30 mSv per hour and 100 mSv per hour to 400 mSv per hour. The verification shall be considered successful when the test shows $\pm 20\%$ agreement between the measured and reference dose equivalent rate and total dose equivalent.

Rationale: Test is the necessary method for verification of this requirement. Instrument operation cannot be simulated or inspected. Exposure to actual radiation fields is required to verify that the instrument is operational and meets design specifications. The verification cannot be performed for all components of the space radiation field in which the vehicle will be exposed. The selected test fields span the range of energy, linear energy transfer, dose equivalents, and dose equivalent rates expected during the missions, specifically radiation fields expected during solar particle events.

4.10.1.4.2 Suited Radiation Absorbed Dose Monitoring

[HS11024V] Absorbed dose monitoring shall be verified by test. The test shall use one flight equivalent instrument to verify the requirement. The test shall be an exposure of the flight equivalent instrument to radiation sources. The test shall use accelerator sources of charged particles with $Z=1$ with energies of 50 MeV, 100 MeV, and 200 MeV. Each radiation source shall deliver a total dose of 10 mGy for each of the dose equivalent ranges of: 0.5 mGy per hour to 15 mGy per hour and 50 mGy per hour to 200 mGy per hour. The verification shall be considered successful when the test shows $\pm 20\%$ agreement between the measured and reference dose rate and total dose.

Rationale: Test is the necessary method for verification of this requirement. Instrument operation cannot be simulated or inspected. Exposure to actual radiation fields is required to verify that the instrument is operational and meets design specifications. The verification cannot be performed for all components of the space radiation field in which the vehicle will be exposed. The selected test fields span the range of energy, Linear Energy Transfer, absorbed doses, and absorbed dose rates expected during the missions, specifically radiation fields expected during solar particle events.

Revision: E	Document No: CxP 70024
Release Date: 11/19/10	Page: 301 of 503
Title: Constellation Program Human-Systems Integration Requirements	

4.10.1.4.3 Stowage for Suit Dosimeters

[HS11004V] Designated stowage for a personal passive dosimeter within the EVA system shall be verified by inspection. The inspection shall consist of a review of the EVA suit system certification hardware. The verification shall be considered successful when the inspection shows the dosimeter can be stowed internally in the suit, excluding the helmet, gloves, and boots, and external to the crewmember's body.

Rationale: No further rationale is required.

4.10.2 Suited Visibility

4.10.2.1 Visual Field of View for a Suited Crewmember

[HS11005V] The field of view needed for a suited crewmember to perform tasks shall be verified by analysis and demonstration. The analysis shall identify suited tasks that require the suited crewmember to view the task in order to complete the task. The demonstration shall consist of suited crewmembers performing the identified tasks. Each identified task shall be demonstrated at least once using a flight-like suit. The verification shall be considered successful when the analysis and demonstration show that a suited crewmember has the field of view necessary to perform tasks.

Rationale: No further rationale is required.

4.10.2.2 Optical Quality for Suited Crewmember

[HS11006V] The optical qualities of suit visors shall be verified by analysis and test. The analysis shall consist of a task analysis and an analysis of relevant legibility data to identify the interfaces that need to be read and interpreted, and the set of worst-case expected conditions during a nominal mission profile that need to be tested. The test shall consist of a legibility test conducted with a minimum of 5 crewmembers, crew designated representatives, or engineering subjects with normal or corrected to normal vision, under the identified list of conditions in a high fidelity flight-like simulator or mockup. The legibility test shall consist of rapid serial visual presentation and subsequent verbal identification by subjects of a representative selection of targets such as hardware labels and software elements (alphanumeric, icons, and symbols). The verification shall be considered successful when the test shows an average identification accuracy of 98% for each type of target.

Rationale: Detailed characteristic visor optical properties will be verified via EVA System level verifications which may be performed in conjunction with the HSIR verification. A flight-like simulator is to be provided by the vehicle office, with joint verification performed in conjunction with legibility verification as per HS7044V. Heritage hardware has typically had minimal success meeting specified perfect optical qualities; therefore, the intent is to ensure that any degradation in helmet optical qualities does not significantly impact legibility.

Revision: E	Document No: CxP 70024
Release Date: 11/19/10	Page: 302 of 503
Title: Constellation Program Human-Systems Integration Requirements	

4.10.3 Crew Functions for the Suited Crewmember

4.10.3.1 Nutrition for Suited Crewmembers

4.10.3.1.1 In-Suit Nutrition During Surface EVA Operations

[HS11007V] Nutrition consumption by a pressurized suited crewmember shall be verified by demonstration. The demonstration shall consist of a pressurized suited subject consuming nutrition. The verification shall be considered successful when the demonstration shows that a pressurized suited crewmember can consume nutrition as specified in HS6062 for surface EVAs.

Rationale: No further rationale is required.

4.10.3.1.2 In-Suit Nutrition During Unpressurized Vehicle Survival

[HS11008V] Nutrition consumption by a pressurized-suited crewmember shall be verified by demonstration. The demonstration shall consist of a pressurized-suited subject consuming nutrition. The verification shall be considered successful when the demonstration shows that a pressurized-suited crewmember can consume nutrition as specified in HS6062 for suited intravehicular operations.

Rationale: No further rationale is required.

4.10.3.2 Hydration for Suited Crewmembers

4.10.3.2.1 In-Suit Hydration During EVA

[HS11009V] Water consumption by a pressurized-suited crewmember shall be verified by demonstration. The demonstration shall consist of a pressurized-suited subject consuming water during simulated EVA tasks. The verification shall be considered successful when the demonstration shows that the pressurized-suited crewmember can consume water as specified in HS6063.

Rationale: No further rationale is required.

4.10.3.2.2 In-Suit Hydration During IVA

[HS11010V] Water consumption by a pressurized-suited crewmember shall be verified by demonstration. The demonstration shall consist of a pressurized-suited subject consuming water during simulated intravehicular tasks. The verification shall be considered successful when the demonstration shows that the pressurized-suited subject can consume water.

Rationale: No further rationale is required.

4.10.3.3 Waste Management

4.10.3.3.1 Vomitus in the Suit

[HS11011V] Not Applicable.

Revision: E	Document No: CxP 70024
Release Date: 11/19/10	Page: 303 of 503
Title: Constellation Program Human-Systems Integration Requirements	

4.10.3.3.2 Nominal Urine Collection in the Suit

[HS11012V] The collection and containment of urine during suited operations shall be verified by analysis and test. The analysis shall determine the capacity of the system. The test shall release liquid into the containment system, where the maximum t value is 10 hours. The amount of released liquid shall be based on the maximum amount expected. The verification shall be considered successful when the analysis and test show that the system collects and contains $500 \text{ mL} + 2 t/24 \text{ L}$ of urine where t is suited duration in hours.

Rationale: No further rationale is required.

4.10.3.3.3 Urine Collection - Suited Contingency

[HS11013V] The contingency suited collection of urine shall be verified by demonstration. The demonstration shall collect and contain 1 L of liquid per day per crewmember using a flight-like suit waste collection system during a simulated unrecoverable vehicle pressure failure. The verification shall be considered successful when the demonstration shows that 1 L of liquid per day per crewmember is collected and contained.

Rationale: No further rationale is required.

4.10.3.3.4 Feces Collection - Suited Contingency

[HS11014V] The contingency suited collection of feces shall be verified by demonstration. The demonstration shall collect and contain 75 grams (by mass) and 75 mL (by volume) of simulated feces per crewmember per day using a flight-like suit waste collection system during a simulated unrecoverable vehicle pressure failure. The verification shall be considered successful when the demonstration shows that the quantity of simulated fecal waste is collected and contained.

Rationale: No further rationale is required.

4.10.4 Prevention and Treatment of Decompression Sickness

4.10.4.1 Denitrogenation

[HS6091V] Maintaining the internal pressure and gaseous oxygen concentration for the required time durations for denitrogenation shall be verified by test. The test shall adjust the pressures and concentrations as defined in HS6091, table Prebreathe Durations for Contingency EVA and table Prebreathe Durations for Nonrecoverable Cabin Depress in an integrated configuration of the vehicle including the suit. The verification shall be considered successful when the test shows that the vehicle can vary pressures and gas concentrations per the denitrogenation protocol.

Rationale: No further rationale is required.

Revision: E	Document No: CxP 70024
Release Date: 11/19/10	Page: 304 of 503
Title: Constellation Program Human-Systems Integration Requirements	

4.10.4.2 DCS Event Pressure

[HS6100V] The system's Decompression Sickness (DCS) initial treatment capability shall be verified by test. The test shall use a structurally flight-like mockup to simulate a recovery from an EVA DCS scenario, initiating DCS treatment, and measuring the atmospheric pressure at the skin surface of a dummy crewmember, assuming that the recovery/treatment chamber pressure is at crewmember initial saturation pressure and that the dummy crewmember is suited at the time the treatment begins. The verification shall be considered successful when the test shows that crewmember initial saturation pressure or more of atmospheric pressure is measured at the dummy crewmember's skin within 20 minutes of test onset.

Rationale: No further rationale is required.

4.10.4.3 DCS Over-pressurization

[HS6081V] Decompression Sickness (DCS) treatment capabilities shall be verified by analysis. The analysis shall evaluate the system's ability to provide a pressure of 156.5 kPa (22.7 psia) (1,174 mmHg) to a DCS affected crewmember via a combination of vehicle and suit pressures. The verification shall be considered successful when the analysis shows that the specified pressure can be achieved by crewmembers within 2 hours of a DCS event and maintained for 6 hours.

Rationale: The 2-hour limit includes the time it takes for the crew to don their suits, assuming they are not suited at the time the need for treatment is realized.

4.10.5 Data for Physiological Parameters

4.10.5.1 Measurement of Physiological Parameters

[HS11015V] The measurement of physiological parameters shall be verified by demonstration. The demonstration shall include a pressurized-suited subject with measurements for each of the specified parameters recorded. The verification shall be considered successful when the demonstration shows that all parameters identified in HS11015, table Measurements of Physiological Parameters are measured by the Constellation Architecture.

Rationale: No further rationale is required.

4.10.5.2 Display of Physiological Parameters

[HS11016V] The display of physiological parameters being measured by the Constellation Architecture shall be verified by demonstration. The demonstration shall send the identified parameters from the Constellation Architecture to the crew display. The verification shall be considered successful when the demonstration shows that all parameters identified in HS11016, table Display of Physiological Parameters are displayed to the crew.

Rationale: No further rationale is required.

Revision: E	Document No: CxP 70024
Release Date: 11/19/10	Page: 305 of 503
Title: Constellation Program Human-Systems Integration Requirements	

4.10.5.3 Alert for Off-Nominal Physiological Parameters

[HS11017V] Alerts for off-nominal physiological parameters shall be verified by demonstration. The demonstration shall send the identified parameters from the Constellation Architecture to the crew. The verification shall be considered successful when the demonstration shows that alerts are provided for all parameters identified in HS11017, table Alerting for Off-Nominal Physiological Parameters to the intended audience.

Rationale: No further rationale is required.

4.10.5.4 Telemetry of Physiological Parameters

[HS11018V] The transmission of physiological parameters for suited operations shall be verified by demonstration. The demonstration shall include the Constellation Architecture transmitting the identified parameters. The verification shall be considered successful when the demonstration shows that all parameters identified in HS11018, table Telemetry of Physiological Parameters are transmitted from the Constellation Architecture.

Rationale: No further rationale is required.

Revision: E	Document No: CxP 70024
Release Date: 11/19/10	Page: 306 of 503
Title: Constellation Program Human-Systems Integration Requirements	

APPENDIX A ACRONYMS AND ABBREVIATIONS AND GLOSSARY OF TERMS

A1.0 ACRONYMS AND ABBREVIATIONS

3D	Three-dimensional
AATD	Aviation Applied Technology Directorate
ac	alternate current
ACES	Advanced Crew Escape Suit
ACGIH	American Council of Governmental Industrial Hygienists
AGARD	Advisory Group for Aerospace Research and Development
ALARA	As Low As Reasonably Achievable
AM	Asymetric Multiplier
AMS	Acute Mountain Sickness
ANSI	American National Standards Institute
ANSUR	Anthropometric Survey of US Army Personnel
ARS	Atmosphere Revitalization System
ASHRAE	American Society of Heating, Refrigerating and Air Conditioning Engineers
BEI	Biological Exposure Indices
BFxRM	Bone Fracture Risk Module
BGI	Bubble Growth Index
BMD	Bone Mineral Density
bpm	beats per minute
BSP	Body Segment Properties
BTE	Barrier Thickness Evaluator
BTU	British Thermal Unit
C	Celsius
CA	Constellation Architecture
CAD	Computer Aided Drafting
CAF	Computerized Anatomical Female
CAIT	Constellation Analysis Integration Tool
cal	calorie (gram)
CARD	Constellation Architecture Requirements Document
cc	cubic centimeter
CDO	Cognitive Deficit Onset
CEV	Crew Exploration Vehicle

Revision: E	Document No: CxP 70024
Release Date: 11/19/10	Page: 307 of 503
Title: Constellation Program Human-Systems Integration Requirements	

CFE	Contractor Furnished Equipment
CFM	cubic feet per minute
CFR	Code of Federal Regulations
CFU	colony forming unit
cm	centimeter
CM	Crew Module Coupling Multiplier
CMO	Crew Medical Officer
CNS	Central Nervous System
CO	carbon monoxide
CO ₂	carbon dioxide
CPR	Cardiopulmonary Resuscitation
CR	Change Request
CSA-CP	Compound Specific Analyzer-Combustion Products
CTB	Cargo Transfer Bag
Cx	Constellation
CxP	Constellation Program
CxSECB	Constellation Systems Engineering Control Board
d	day (as in mg/d or mg/d-person)
dB	decibel
dBA	decibels adjusted
dc	direct current
DCS	Decompression Sickness
DM	Distance Multiplier
DoD	Department of Defense
DOT	Department of Transportation
DR	Dynamic Response
DRD	Data Requirements Document
DR _{lim}	Dynamic Response Limit
DRM	Design Reference Mission
DSNE	Design Specification for Natural Environments
DXA	Dual-Energy X-ray Absorbance
E3	Electromagnetic Environmental Effects
EAWG	Exploration Atmospheres Working Group
ECLSS	Environmental Control and Life Support Subsystem
EER	Estimated Energy Requirements

Revision: E	Document No: CxP 70024
Release Date: 11/19/10	Page: 308 of 503
Title: Constellation Program Human-Systems Integration Requirements	

EM	Electromagnetic
EMI	Electromagnetic Interference
EMU	Extravehicular Mobility Unit
EOM	End-of-Mission
EPA	Environmental Protection Agency
ERB	Engineering Review Board
ESD	Electrostatic Discharge
EVA	Extravehicular Activity
F	Fahrenheit
FAA	Federal Aviation Administration
FCE	Flight Crew Equipment
FD	Flight Day
FED	Federal
FFISS	Fully Functional International Space Station
FFT	Fast Fourier Transform
fG	frequency in GHz
fl	fluid
fM	frequency in MHz
FM	Frequency Multiplier
FOD	Foreign Object Debris
FRI	Fracture Risk Index
ft	foot
g	gram gravity
g/s	g per second (<i>where a "g" equals 9.8 meters per second squared</i>)
GCR	Galactic Cosmic Radiation
GFE	Government Furnished Equipment
GHz	gigaHertz
GN&C	Guidance, Navigation, and Control
gn	acceleration of free fall, standard
GO	Ground Operations
GOST	Russian State Standard
GS	Ground Support
GSE	Ground Support Equipment
HCl	hydrogen chloride

Revision: E	Document No: CxP 70024
Release Date: 11/19/10	Page: 309 of 503
Title: Constellation Program Human-Systems Integration Requirements	

HCN	hydrogen cyanide
HEPA	High Efficiency Particulate Air
HIC	Head Injury Criteria
HM	Horizontal Multiplier
hr	hour
HSIR	Human-Systems Integration Requirements
Hz	hertz
ICD	Interface Control Document
ICES	International Conference on Environment Systems
IEEE	Institute of Electronic and Electrical Engineers
IESNA	Illuminating Engineering Society of North America
in	inch
IRD	Interface Requirements Document
IRL	Indy Racing League
ISBN	International Standard Book Number
ISO	International Standards Organization
ISS	International Space Station
IVA	Intravehicular Activity
J	joule
JSC	Johnson Space Center
JSSG	Joint Service Specification Guide
keV	kiloelectronvolt
kg	kilogram
kHz	kilohertz
kJ	kilojoule
km	kilometer
kPa	kilopascal
L	liter
LADTAG	Lunar Atmosphere Dust Toxicity Assessment Group
LAm _{ax}	maximum A-weighted overall sound pressure level
lb	pound
LC	Load Constant
LCC	Launch Control Center
LCG	Liquid Cooling Garment
LCVG	Liquid Cooling and Ventilation Garment
LEO	Low Earth Orbit

Revision: E	Document No: CxP 70024
Release Date: 11/19/10	Page: 310 of 503
Title: Constellation Program Human-Systems Integration Requirements	

L _{eq}	Equivalent Continuous Noise Level
LET	Linear Energy Transfer
LiOH	Lithium Hydroxide
LOC	Loss of Crew
LOM	Loss of Mission
LOTS	Loss of Tracking Skills
LRU	Line Replaceable Unit
LSAM	Lunar Surface Access Module
m	meter
m/s ²	meters per second squared
m ²	square meters
m ³	cubic meters
ma	milliampere
MAG	Maximum Absorbency Garment
Max	maximum
MCC	Mission Control Center
MCL	Maximum Contamination Level
MeV	Mega electron Volt
mg	milligram
mGy	milligray
MHz	megahertz
mHz	millihertz
MIL	Military
min	minute
Min	minimum
mJ	millijoule
mL	milliliter
mm	millimeter
mmHg	millimeter of mercury
MMOD	Micro Meteoroid Orbital Debris
MO	Mission Operations
MORD	Medical Operations Requirements Document
MPE	Maximum Permissible Exposure
MR	Metabolic Rate
ms	millisecond
MS	Mission Systems
MSDV	Motion Sickness Dose Value

Revision: E	Document No: CxP 70024
Release Date: 11/19/10	Page: 311 of 503
Title: Constellation Program Human-Systems Integration Requirements	

MSIS	Man-Systems Integration Standards
mSv	millisievert
MTBI	Minor Traumatic Brain Injury
mW	milliwatt
N/A	Not Applicable
N ₂	nitrogen
NASA	National Aeronautics and Space Administration
NASCAR	National Association for Stock Car Auto Racing
NCRP	National Council on Radiation Protection and Measurements
NIOSH	National Institute for Occupational Safety and Health
NIR	Non-Ionizing Radiation
NIST	National Institute of Standards and Technology
nm	nanometer
NO ₂	nitrate
NO ₃	nitrite
NPR	NASA Procedural Requirement
NTU	Nephelometric (Turbidity) Units
O ₂	oxygen
OPR	Office of Primary Responsibility
ORU	Orbital Replacement Unit
OSHA	Occupational Safety and Health Administration
oz	ounce
Pa	Pascal
PCU	Platinum-Cobalt Units
PDA	Personal Digital Assistant
PEPC	Portable Equipment, Payloads, and Cargo
pg	Page
ppCO ₂	partial pressure carbon dioxide
PPE	Personal Protective Equipment
ppm	parts per million
ppN ₂	partial pressure Nitrogen
ppO ₂	partial pressure Oxygen
psi	pound per square inch
psia	pound per square inch absolute
psid	pound per square inch differential

Revision: E	Document No: CxP 70024
Release Date: 11/19/10	Page: 312 of 503
Title: Constellation Program Human-Systems Integration Requirements	

psig	pound per square inch gauge
QCT	Quantitative Computerized Tomography
RER	Respiratory Exchange Ratio
RF	Radio Frequency
RH	Relative Humidity
RHC	Rotational Hand Controller
rms	root mean square
rpm	revolution per minute
RWL	Recommended Weight Limit
SAE	Society of Automotive Engineers
SAS	Space Adaptation Syndrome
SCAPE	Self-Contained Atmosphere Protective Equipment
SCUBA	Self-Contained Underwater Breathing Apparatus
SE&I	Systems Engineering and Integration
SEBS	Spacehab Emergency Breathing System
sec	second
SEMA	Specialty Equipment Market Association
SFI	Formerly SEMA Foundation, Inc.
SI	International Standard of Units
SID	Standard Interface Document
SIG	System Integration Group
SIL	Speech Interference Level
SM	Service Module
SMAC	Spacecraft Maximum Allowable Concentration
SP	Special Publication
SPE	Solar Particle Event
SPL	Sound Pressure Level
SRD	System Requirements Document
SSP	Space Shuttle Program
STD	Standard
STPD	standard temperature and dry gas at standard barometric pressure: 0 °C, 101.3 kPa, dry
STS	Space Transportation System
SWEG	Spacecraft Water Exposure Guideline
TBD	To Be Determined
TBDM	Tissue Bubble Dynamics Model

Revision: E	Document No: CxP 70024
Release Date: 11/19/10	Page: 313 of 503
Title: Constellation Program Human-Systems Integration Requirements	

TBR	To Be Resolved
TDS	Task Description Sheet
TEE	Total Energy Expenditure
THC	Translational Hand Controller
TLV	Threshold Limit Values
TLX	Task Load Index
TM	Транспортный модифицированный (Modified Transport)
TMA	Транспортный модифицированный антропометрический (Modified Transport - Anthropometric)
TON	Threshold Odor Number
TTN	Threshold Taste Number
TWA	Time Weighted Average
US	United States
USAAVSCOM	United States Army Aviation Systems Command
UV	Ultraviolet
V	Volt
VM	Verticle Multiplier
VO ₂	maximal oxygen consumption
W	Watts
WMS	Waste Management System
WORF	Window Observational Research Facility
WSTF	White Sands Test Facility
µg	microgram
µm	micrometer

Revision: E	Document No: CxP 70024
Release Date: 11/19/10	Page: 314 of 503
Title: Constellation Program Human-Systems Integration Requirements	

A2.0 GLOSSARY OF TERMS

Term	Definition
Abort	Early termination of the mission or mission phase prior to reaching the mission destination due to a failure or other condition that endangers the crew. At the moment an Abort is declared, the focus of the operation switches from flying the planned mission to saving the crew. A successful Abort ultimately places the crew in the portion of the space flight system normally used for reentry, and places them in a safe situation suitable for successful return and rescue. Aborts include scenarios where the vehicle is damaged or not recovered.
Accessible	An item is considered accessible when it can be operated, manipulated, serviced, removed, or replaced by the suitably clothed and equipped user with applicable body dimensions conforming to the anthropometric range and database specified by the procuring activity or if not specified by the procuring activity, with applicable 5th to 95th percentile body dimensions. Applicable body dimensions are those dimensions which are design-critical to the operation, manipulation, removal, or replacement task.
Advanced Life Support	<p>For the Constellation Program, "Advanced Life Support" is defined as that level of medical care which provides the capability to stabilize and/or reverse a life-threatening illness or injury as defined in the following criteria:</p> <ul style="list-style-type: none"> A. Unstable vital signs (heart rate <42 or >100, respiratory rate <8 or >30, systolic blood pressure <90 or >200, pulse oximetry <90% on room air, signs of confusion, pallor, extreme pain, or altered mental status). B. Use of an artificial airway, assisted breathing device, or ventilator. C. Need for any intravenous drug infusion(s). D. Recent or anticipated use of defibrillator, cardioversion, or transcutaneous pacing. E. Need for continuous physiological monitoring. F. Need for continuous monitoring and care by another crewmember. G. Failure of one or more organ system(s). <p>Examples of "Advanced Life Support" hardware may include a respiratory support device, intravenous pharmaceuticals and fluids, defibrillation, etc.</p>

Revision: E	Document No: CxP 70024
Release Date: 11/19/10	Page: 315 of 503
Title: Constellation Program Human-Systems Integration Requirements	

Term	Definition
Advisory	A message that indicates a safe or normal configuration, operation of essential equipment, or imparts information for routine action purposes.
Alert	Activation of any aural alarms, indicators, light, or flag used to make the operators aware of a particular situation.
Alerting System	System that encompasses aural tones, indicators, lights, lighted buttons and flags that raise operators' awareness of a particular situation. Includes emergency, warning, caution and advisory classes of alerts. Commonly referred to as the "caution and warning" system.
Ambulatory Care	<p>The level of medical care which a crewmember can independently provide to himself or herself. While the flight surgeon might be consulted, no complex interventions or assistance from other crewmembers are needed. Many of the conditions which require "ambulatory care" are minor ailments which would be likely to resolve eventually even in the absence of treatment, but may still in the interim have significant mission impact. In addition, it should be noted that if a minor ailment is not properly diagnosed and treated in its initial stages, it may progress to a much more severe condition; e.g., bronchitis if untreated may become pneumonia, a bladder infection if untreated may lead to a kidney infection (pyelonephritis) or sepsis. Criteria for "ambulatory care" are defined as:</p> <ul style="list-style-type: none"> A. Administration of oral or topical medications. B. No more than one procedure required for resolution of condition (example: single dose of intravenous medication or reduction of dislocation). C. Ability to perform the majority of scheduled mission tasks.
Auditory Annunciation	An audible computer-generated speech or non-speech signal. Examples include an emergency klaxon and a speech-based message.
Auditory Annunciation	An audible computer-generated speech or non-speech signal. Examples include an emergency klaxon and a speech-based message.
Basic Life Support	The level of medical care which provides the capability for Cardiopulmonary Resuscitation (CPR), basic airway management, and crew immobilization.

Revision: E	Document No: CxP 70024
Release Date: 11/19/10	Page: 316 of 503
Title: Constellation Program Human-Systems Integration Requirements	

Term	Definition
Catastrophic Hazard	A condition that may cause the loss of life, permanently disabling injury, or a loss of flight assets.
Caution	An event that needs attention, but not immediate action.
Clinical Diagnostics	The level of medical care which provides the capability for assessing vital signs and medical conditions and reaching a clinical diagnosis. Examples of "Clinical Diagnostics" hardware may include stethoscope, thermometer, blood pressure cuff, urine chemistry strips, portable limited body fluid analyzer, etc.
Contingency EVA	An EVA performed to deal with critical failures or circumstances, which are not adequately protected by redundancy or other means. An EVA not scheduled in the pre-mission timeline required to affect the safety of the crew, outpost, and/or safe return of the vehicle.
Crew	Human onboard the spacecraft or space system during a mission. May also be referred to as Astronauts.
Crew Survival	Ability to keep the crew alive using capabilities such as abort, escape, safe haven, emergency egress, and rescue in response to an imminent catastrophic condition
Crew Survival Capabilities	Capabilities incorporated into program architecture and operations to preserve the crew's life in the presence of imminent catastrophic conditions. Examples include abort, escape, and safe haven.
Crew Interface	Any part of a vehicle through which information is transferred between the crew and the vehicle, whether by sight, sound, or touch. Usable, well-designed crew interfaces are critical for crew safety and productivity, and minimize training requirements.
Critical Hazard	A condition that may cause severe/lost time injury or incapacitation, or major damage to flight assets, or loss of Program critical assets, or loss of primary mission objectives.
Data Accuracy	The degree to which information in a digital database matches true or accepted values. Accuracy is an issue pertaining to the quality of data and the number of errors contained in a dataset.
Data Fidelity	Data qualities that include accuracy, precision, reliability, latency (data freshness), resolution, and completeness.

Revision: E	Document No: CxP 70024
Release Date: 11/19/10	Page: 317 of 503
Title: Constellation Program Human-Systems Integration Requirements	

Term	Definition
Data Precision	The level of measurement and exactness of description in a database. Precise locational data may measure position to a fraction of a unit. Precise attribute information may specify the characteristics of features in great detail. Note that precise data, no matter how carefully measured, may be inaccurate.
Data Reliability	The degree to which data is the same when sampled repeatedly.
Dental Care	The level of medical care which provides the capability to diagnose and treat oral/dental conditions. Examples of "Dental Care" hardware may include temporary filling or crown, tooth extraction, abscess drainage hardware, etc.
Display	A display is anything that provides visual, auditory and/or haptic information to crewmembers (e.g., label, placard, tone, or display device). The term "display" includes text-based user interfaces, as well as Graphical User Interfaces (GUIs).
Display Device	The hardware used to present visual, aural, and tactile information to the crew or ground operations personnel. Display devices include computer monitors and Personal Digital Assistants (PDAs).
Emergency (relative to crew alerting systems)	Specifically identified life threatening warning event that requires immediate action.
Emergency Systems	Safeguards against hazardous situations that directly affect the crew that would be used for the prevention of loss-of-life. Examples include abort systems, fire suppression systems and crew escape systems. Emergency systems are not a leg of fault tolerance.
Escape	In-flight removal of crew from the portion of the space system normally used for reentry, due to rapidly deteriorating and hazardous conditions, thus placing them in a safe situation suitable for survivable return or recovery . Escape includes, but is not limited to, those capabilities that utilize a portion of the original space system for the removal (e.g., pods, modules, or fore bodies). (NPR 8705.2A, Human-Rating Requirements For Space Systems)
EVA	Operations performed by suited crew outside the pressurized environment of a flight vehicle or habitat (during space flight or on a destination surface).

Revision: E	Document No: CxP 70024
Release Date: 11/19/10	Page: 318 of 503
Title: Constellation Program Human-Systems Integration Requirements	

Term	Definition
Field of View	All points that can be viewed directly by at least one eye, given the combination of achievable eye, head, and body movement. The field of view is restricted by obstructions imposed by the facial structure around the eye and artificial apertures placed in front of the eye such as the crewmember's helmet, a cabin window, and/or other equipment. Achievable movement will vary for different flight phases and operational tasks dependent upon the respective constraints to movement (such as being suited, seated, and/or restrained) and respective conditions (such as g-loads).
First Aid	The level of medical care which provides the capability for treating minor medical conditions and minor trauma. Example "First Aid" items may include headache medication, nasal decongestant, bandages, eye drops, etc.
Functional Reach Envelope	Reach envelope is the volume representing the reach limits of the human body. Functional reach envelope, or work envelope, refers to the volume within which a specific function or task can be performed. The shape and volume of functional reach envelopes are dependent on the task, motion, and function to be accomplished by the reach action. Limited reach envelope data in standard anthropometrical positions are available in sources of static and dynamic anthropometrical data. Unfortunately, reach data for space applications, like range of motion data, are greatly affected by the restricted postures maintained by crewmembers while wearing bulky flight suits and being restrained by straps in sometimes awkward postures. During hyper gravity, due to an increase in whole body weight, limb weight, and segment weights, the range of motion for most joints will become restricted. Most importantly, the mobility of the neck, legs, and arms will be severely restricted, reducing the size of functional reach envelopes.
Ground Support Equipment	Non-flight systems, equipment, or devices necessary to support such operations as transporting, receiving, handling, assembly, inspection, test, checkout, servicing, launch, and recovery of space systems.

Revision: E	Document No: CxP 70024
Release Date: 11/19/10	Page: 319 of 503
Title: Constellation Program Human-Systems Integration Requirements	

Term	Definition
Heat Load	Heat being imposed upon a system by any means (metabolism, electrical resistance, external environment, etc.). This heat must be removed or otherwise managed in order to maintain temperature.
Housekeeping	Actions performed by the crew during a mission to maintain a healthy and habitable environment within the spacecraft. Examples of housekeeping activities include biocidal wiping of spacecraft interior surfaces, cleaning or servicing of food preparation or hygiene facilities, and trash management.
Human Engineering	Human Engineering (also referred to as Human Factors Engineering/Human Factors/Ergonomics) is the scientific discipline concerned with the understanding of interactions among humans and other elements of a system, and the profession that applies theory, principles, data, and other methods to design in order to optimize human well-being and overall system performance.
Information Management Functions	Information management functions include the collection, organization, use, control, dissemination, and disposal of information.
Legibility	The extent to which alphanumeric characters and symbols are sufficiently distinct to be easily perceived, deciphered, or recognized.
Loss of Crew	Death of or permanently debilitating injury to one or more crewmembers
Loss of Mission	Loss of or inability to complete significant/primary mission objectives.
Medical Imaging	The level of medical care which provides the capability to acquire diagnostic quality external and internal images of the human body with or without remote guidance from terrestrial experts. Examples of "Imaging" hardware may include digital cameras, ultrasound, x-ray equipment, etc.
Mission Critical	An event, system, subsystem or process that must function properly in order to prevent loss of mission, launch scrub, or major facility damage.
Operator	A crewmember serving the role of pilot or commander.

Revision: E	Document No: CxP 70024
Release Date: 11/19/10	Page: 320 of 503
Title: Constellation Program Human-Systems Integration Requirements	

Term	Definition
Permanent Disability	A non-fatal occupational injury or illness resulting in permanent impairment through loss of, or compromised use of, a critical part of the body, to include major limbs (e.g., arm, leg), critical sensory organs (e.g., eye), critical life-supporting organs (e.g., heart, lungs, brain), and/or body parts controlling major motor functions (e.g., spine, neck). Therefore, permanent disability includes a non-fatal injury or occupational illness that, in the opinion of competent medical authority, permanently incapacitates a person to the extent that he or she cannot be rehabilitated to achieve gainful employment in their trained occupation and results in a medical discharge from duties or civilian equivalent.
Population Analysis	Population analysis utilizes statistical or mathematical tools to interpret results of the testing of a representative sample of subjects. Measures such as fit, reach, and strength are extrapolated or interpolated for comparisons against the entire range of potential crewmembers in order to ensure an adequate selection test of subjects has been made, and to determine whether the design successfully accommodates the extremes of the crew population.
Stakeholder	An individual or organization having an interest (or stake) in the outcome or deliverable of a program or project.
Surgical Care	The level of medical care which provides the capability to treat internal medical conditions resulting from illness or injury that require intervention beyond pharmaceuticals. Local, regional, or systemic anesthesia may be required for successful administration of care. Examples of "Surgical Care" hardware may include surgical instruments, endoscopic equipment, high intensity focused ultrasound, etc.

Revision: E	Document No: CxP 70024
Release Date: 11/19/10	Page: 321 of 503
Title: Constellation Program Human-Systems Integration Requirements	

Term	Definition
Sustained Acceleration	Acceleration event, linear or rotational, with duration of greater than 0.5 seconds. For sustained acceleration events where acceleration peaks more than once and dwells at a lower acceleration between, the following rule shall be used to determine if the event is considered to be one combined event or two separate events. For each acceleration level, if the duration between two sustained events is longer than the duration of the first event, then the event is considered two separate events. If the duration between the two events is less than or equal to the duration of the first acceleration event, they are to be considered one event. This rule is to be used for each axis in the event separately.
System	Physical entities that have functional capabilities allocated to them necessary to satisfy Architecture-level mission objectives. Systems can perform all allocated functions within a mission phase, or through mated operations with other Constellation systems (e.g., Orion, Altair.)
Task Analysis	Task analysis is an activity that breaks a task down into its component levels. It involves 1) the identification of the tasks and subtasks involved in a process or system, and 2) analysis of those tasks (e.g., who performs them, what equipment is used, under what conditions, the priority of the task, dependence on other tasks). The focus is on the human and how they perform the task, rather than the system. Results can help determine the displays or controls that should be developed/used for a particular task, the ideal allocation of tasks to humans vs. automation, and the criticality of tasks, which will help drive design decisions.
Telemedicine	The level of medical care which provides the capability for real-time or store and forward consultation with a Flight Surgeon and/or medical consultants for the purpose of enhanced quality of medical diagnosis and treatment of an ill or injured crewmember.
Transient Acceleration	Acceleration event, linear or rotational, with a duration of less than or equal to 0.5 seconds.

Revision: E	Document No: CxP 70024
Release Date: 11/19/10	Page: 322 of 503
Title: Constellation Program Human-Systems Integration Requirements	

Term	Definition
Trauma Care	The level of medical care which provides the capability to stabilize a crewmember injured by blunt or penetrating trauma. Examples of "Trauma Care" hardware may include suturing capability, parenteral antibiotics, splints, chest tube and closed drainage, intravenous fluids, etc.
Unimpeded Access	Immediately visible and accessible without being blocked or constrained by other equipment. Unimpeded Access is important for Emergency Systems and other critical items.
Vehicle	Vehicle refers to any constellation element including whether a spacecraft or space system (e.g., habitat). The term vehicle includes the structure as well as all of the equipment and outfitting within the structure.
Visual Annunciation	A visual, computer-generated text- or graphics-based signal. Examples include warning messages and flashing icons.
Warning	An event that requires immediate action because it has the potential to become a life/mission threat.

Revision: E	Document No: CxP 70024
Release Date: 11/19/10	Page: 323 of 503
Title: Constellation Program Human-Systems Integration Requirements	

Term	Definition
Window Cover	<p>An internal non-pressure containing, transparent sheet or pane usually of a different material than the window panes such as polycarbonate or other material, intended to protect the underlying window pressure and/or protective pane(s) from incidental crew contact. A window cover is normally not considered an integral part of the window assembly and in such cases where it is not an integral part of the window assembly, a window cover has at least Category D optical properties per JSC 63307 except with respect to wavefront where instead the transmitted wavefront error is at least 1 wave over any 25 mm (~1 in) diameter sub-aperture within the central 80% (minimum) of the physical area of the window where the reference wavelength is 632.8 nm (excluding flight loads, pressure loads, and temperature gradients). Window covers may also serve as a Window Filters. In such cases where a window cover also serves as a window filter the transmittance for hazardous, non-ionizing radiation wavelengths is reduced to safe levels. Window covers are removable and reinstallable or operable without the use of tools by one crew member in less than ten seconds. Window covers can be considered a consumable and should be replaced after some period of time when their optical quality has become degraded. Window covers that are integral to the window assembly are considered protective panes.</p>

Revision: E	Document No: CxP 70024
Release Date: 11/19/10	Page: 324 of 503
Title: Constellation Program Human-Systems Integration Requirements	

Term	Definition
Window Filter	<p>An internal, non-pressure containing, transparent sheet or pane usually of a different material than the window panes such as polycarbonate or other material, or alternatively a coating applied to the window such as an antireflective coating, intended to reduce reflectivity and/or glare and/or filter non-ionizing radiation hazards to safe levels. A window filter is not normally considered an integral part of the window assembly and may also serve as a window cover. Non-integral window filters can be considered a consumable and should be replaced after some period of time when their optical quality has become degraded. Non-integral window filters are removable and reinstallable or operable without the use of tools by one crew member in less than ten seconds. Window filters that are integral to the window assembly are considered protective panes. Electrochromatic windows that filter sufficiently would be considered to have integral window filters and may be used in lieu of conventional, non-integral window filters.</p>
Window Protective Pane	<p>Either an external or internal, non-pressure containing, transparent pane that is intended to protect the underlying window pressure pane(s) from natural and induced environmental degradation such as contamination, erosion, debris impacts, and incidental crew contact. A protective pane is considered an integral part of the window assembly and is of at least of the same optical quality as the window pane(s) it protects. Protective panes are easily removable from the window assembly and reinstallable onto the window assembly within 1 hour EVA or 10 minutes IVA with the use of a minimal set of EVA tools (EVA) or standard hand tools (IVA) by one crew member. Protective panes can be considered a sacrificial consumable and should be replaced after some period of time when their optical quality has become degraded below the category level per JSC 63307 for which they were designed. Protective panes that are not integral to the window assembly are considered window covers.</p>

Revision: E	Document No: CxP 70024
Release Date: 11/19/10	Page: 325 of 503
Title: Constellation Program Human-Systems Integration Requirements	

Term	Definition
Window Shade	<p>An internal, non-pressure containing, opaque sheet or pane intended to block external light from entering the interior of a crew cabin. A window shade is not normally considered an integral part of the window assembly and as such can be considered a consumable and should be replaced after some period of time when it has become worn. Window shutters that are integral to the window assembly can be considered window shades. Electrochromatic windows that darken sufficiently would be considered to have integral window shades and may be used in lieu of conventional, non-integral window shades.</p>
Window Shutter	<p>An internally operable or an internally and remotely operable, external opaque shield intended to prevent natural and induced environmental degradation (contamination, erosion, and debris impacts) of the window, particularly the outboard-most window pane. Window shutters have open and close indicators that are readable from onboard and remote locations regardless of the mode of operation either manual or electronic. Window shutters are considered an integral part of the window assembly and can be operated through their full range of motion by one crew member from fully open to fully closed or vice versa in less than 10 seconds without the use of any tools. Window shutters may also serve as window shades.</p>
Workstation	<p>A place designed for a specific task or activity from where work is conducted or operations are directed. Workstations include cockpits, robotics control stations, or any work area that includes work surfaces, tools, equipment, or computers.</p>

Revision: E	Document No: CxP 70024
Release Date: 11/19/10	Page: 326 of 503
Title: Constellation Program Human-Systems Integration Requirements	

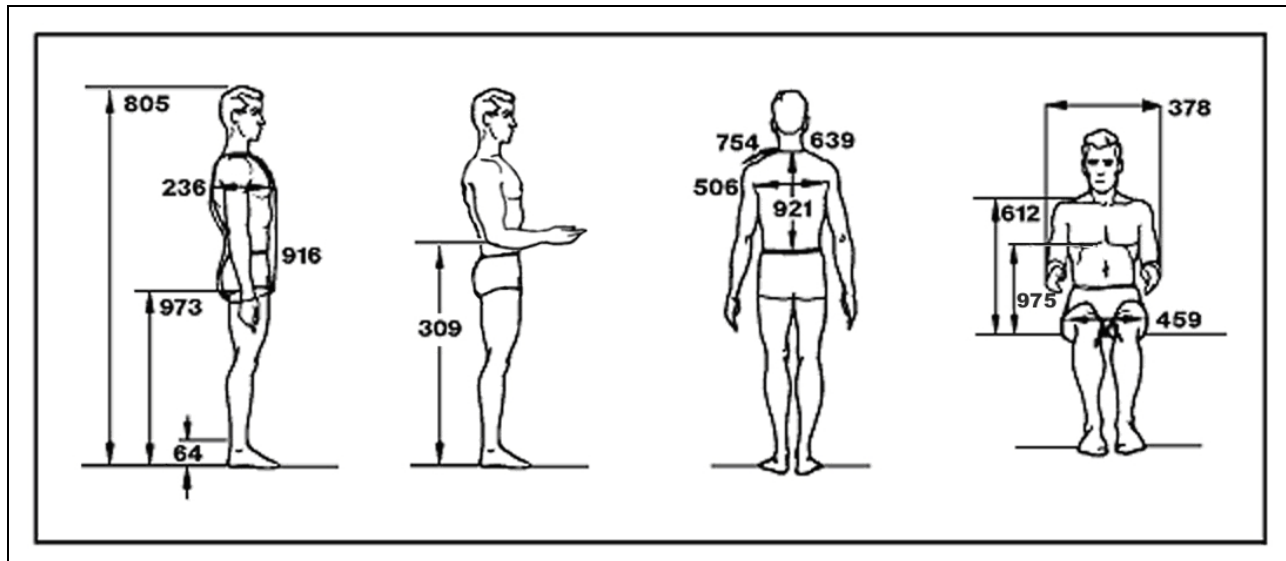
APPENDIX B ANTHROPOMETRY, BIOMECHANICS, AND STRENGTH

B1.0 ANTHROPOMETRY

The data in this section are from the population in the 1988 Anthropometric Survey of US Army Personnel (ANSUR) (ref. Natick/TR-89/044), projected forward by NASA to 2015 to account for the expected small growth in the size of members of the US population. Note that for measurements that include the length of the spine, 3% of stature must be added to allow for spinal elongation due to micro-gravity exposure.

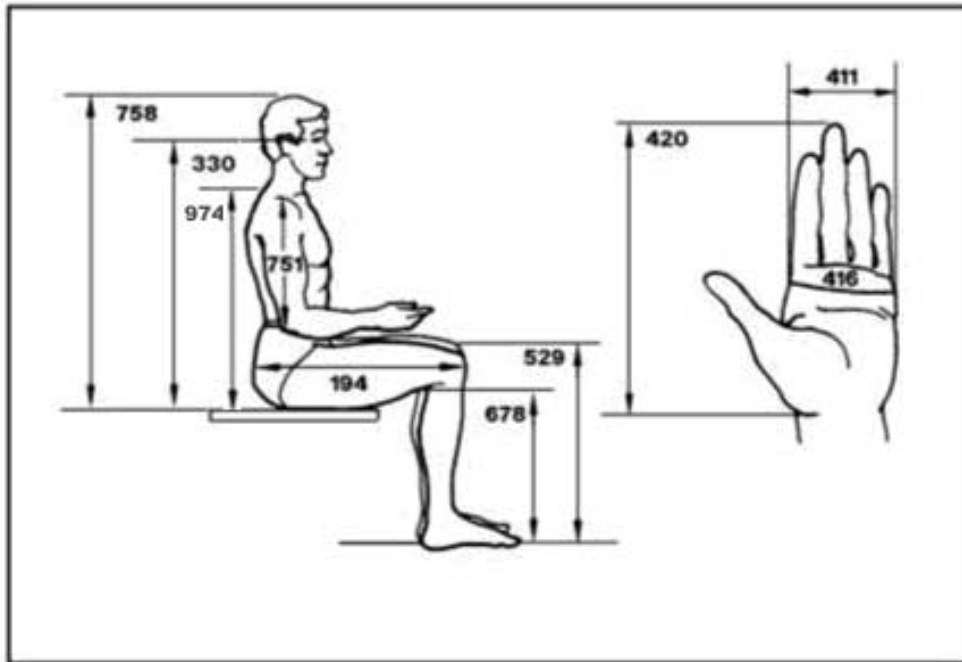
Tables Anthropometric Dimensional Data for American Female and Male, Vehicle Design Critical Anthropometry Dimensions, and Suit Design Critical Anthropometry Dimensions contain a data range for general anthropometric dimensions under minimally clothed condition. Specific anthropometric dimensions that are unique to Constellation vehicle operations are provided in table Vehicle Design Critical Anthropometry Dimensions. Specific anthropometric dimensions that are critical for designing the space suits are provided in table Suit Design Critical Anthropometry Dimensions. Table Vehicle Design Critical Anthropometry Dimensions and table Suit Design Critical Anthropometry Dimensions contain an anthropometric data range not only for a minimally clothed condition but also for suited (unpressurized and pressurized) conditions. Users are advised to use the data appropriately. It should be noted that the suit dependent data were derived by calculating the deltas in measurements between suited and unsuited conditions from a select sample of test subjects. It should also be noted that the test involved using the ACES type suit.

TABLE B1-1 - ANTHROPOMETRIC DIMENSIONAL DATA FOR AMERICAN FEMALE
AND MALE

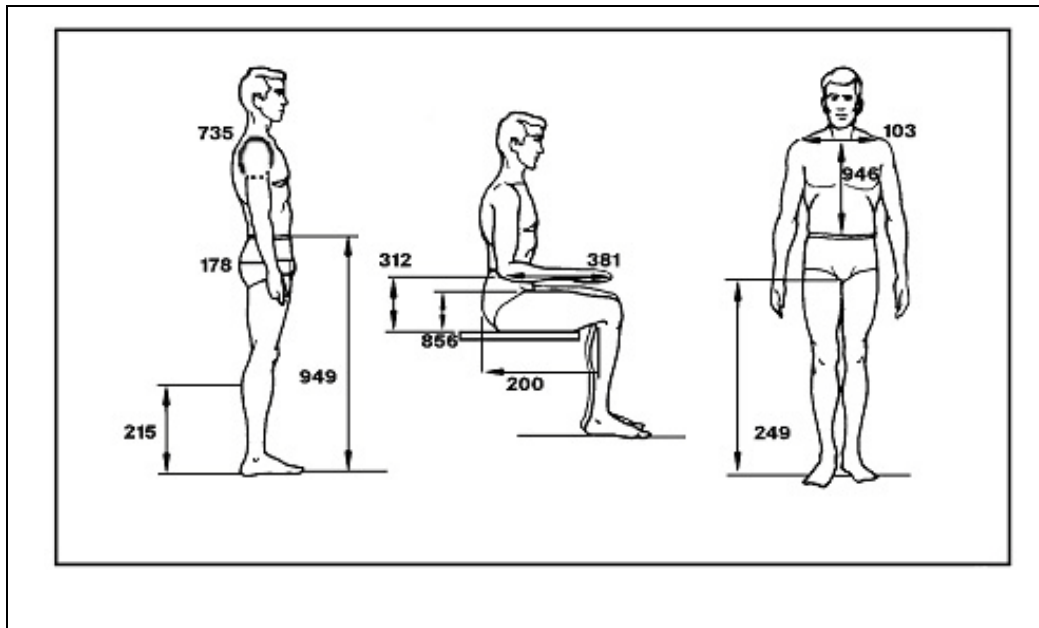


No.	Dimension	Min (cm, (in))	Max (cm, (in))
805	Stature	148.6 (58.5)	194.6 (76.6)
973	Wrist height	70.3 (27.7)	96.3 (37.9)
64	Ankle height	4.8 (1.9)	8.1 (3.2)
309	Elbow height (rest height standing)	89.9 (35.4)	120.7 (47.5)
236	Bust depth (chest depth)	19.1 (7.5)	30.2 (11.9)
916	Vertical trunk circumference	134.9 (53.1)	181.9 (71.6)
612	Mid-shoulder height, sitting	52.6 (20.7)	71.1 (28.0)
459*	Hip breadth, sitting	31.5 (12.4)	46.5 (18.3)
921	Waist back	39.1 (15.4)	55.9 (22.0)
506	Interscye	29.3 (11.5)	48.0 (18.9)
639	Neck circumference	27.8 (10.9)	43.4 (17.1)
754	Shoulder length (side neck-to-acromion horizontal distance)	12.0 (4.7)	18.0 (7.1)
378	Forearm-forearm breadth	38.9 (15.3)	66.0 (26.0)
975	Chest height, sitting	33.8 (13.3)	50.3 (19.8)

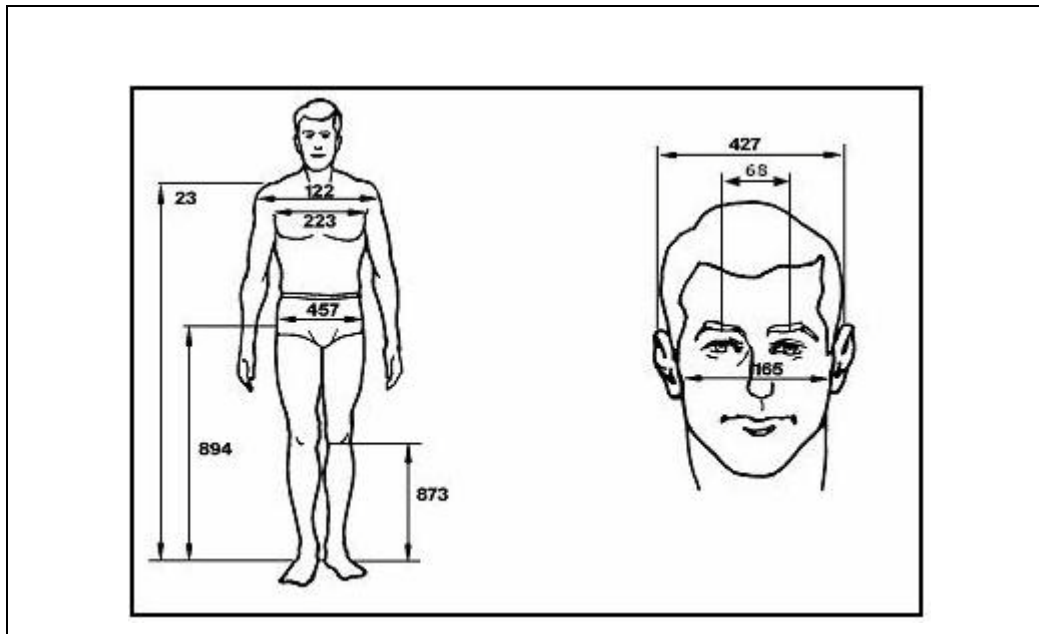
*For seated measurements, the largest female hip breadth is larger than the largest male hip breadth, and the smallest male hip breadth is smaller than the smallest female hip breadth; therefore, male data are used for the Min dimension, and female data are used for the Max dimension.



No.	Dimension	Min (cm [in])	Max (cm [in])
758	Sitting height	77.7 (30.6)	101.3 (39.9)
330	Eye height, sitting	66.5 (26.2)	88.9 (35.0)
529	Knee height, sitting	45.5 (17.9)	63.5 (25.0)
678	Popliteal height	33.0 (13.0)	50.0 (19.7)
751	Shoulder-elbow length	29.6 (11.6)	41.9 (16.5)
194	Buttock-knee length	52.1 (20.5)	69.9 (27.5)
420	Hand length	15.8 (6.2)	22.1 (8.7)
411	Hand breadth	7.1 (2.8)	10.2 (4.0)
416	Hand circumference	16.8 (6.6)	24.1 (9.5)
974	Cervicale height, sitting	56.6 (22.3)	76.2 (30.0)

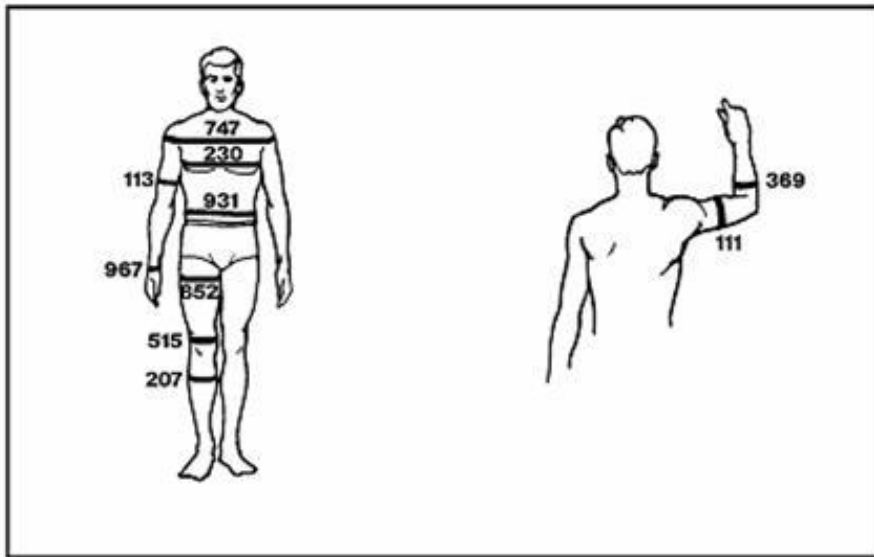


No.	Dimension	Min (cm [in])	Max (cm [in])
949	Waist height	86.6 (34.1)	119.6 (47.1)
249	Crotch height	66.5 (26.2)	95.8 (37.7)
215	Calf height	25.9 (10.2)	41.4 (16.3)
103	Biacromial breadth	32.3 (12.7)	44.5 (17.5)
946	Waist front	34.1 (13.4)	48.8 (19.2)
735	Scye circumference	31.9 (12.6)	52.1 (20.5)
178	Buttock circumference	84.1 (33.1)	114.8 (45.2)
312	Elbow rest height	16.2 (6.4)	30.0 (11.8)
856	Thigh clearance	13.0 (5.1)	20.1 (7.9)
381	Forearm hand length	38.7 (15.2)	54.6 (21.5)
200	Buttock-popliteal length	42.2 (16.6)	57.2 (22.5)

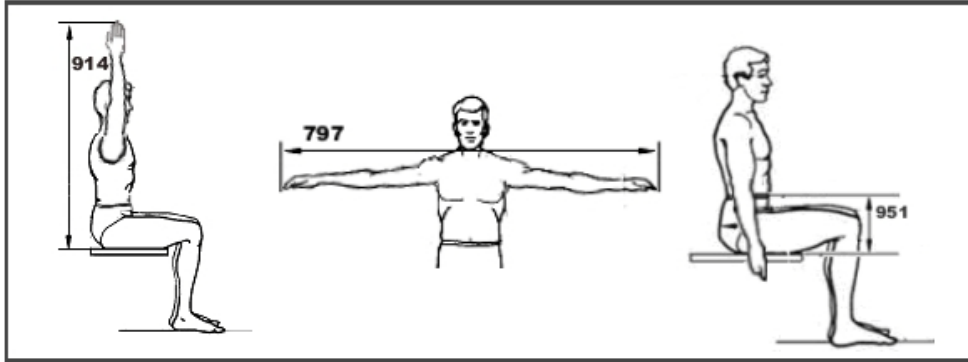


No.	Dimension	Min (cm [in])	Max (cm [in])
23	Acromial (shoulder) height	120.4 (47.4)	161.8 (63.7)
894	Trochanteric height	75.2 (29.6)	105.4 (41.5)
873	Knee Height, Midpatella	39.6 (15.6)	57.9 (22.8)
122	Bideloid (shoulder) breadth	37.8 (14.9)	56.1 (22.1)
223	Chest breadth	23.5 (9.3)	39.4 (15.5)
457*	Hip breadth	29.8 (11.7)	40.6 (16.0)
165	Bizgomatic (face) breadth	12.0 (4.7)	15.5 (6.1)
427	Head breadth	13.3 (5.2)	16.5 (6.5)
68	Interpupillary Breadth	5.3 (2.1)	7.4 (2.9)

*For standing measurements, the largest female hip breadth is larger than the largest male hip breadth; therefore, female data are used for both the Min dimension and the Max dimension.

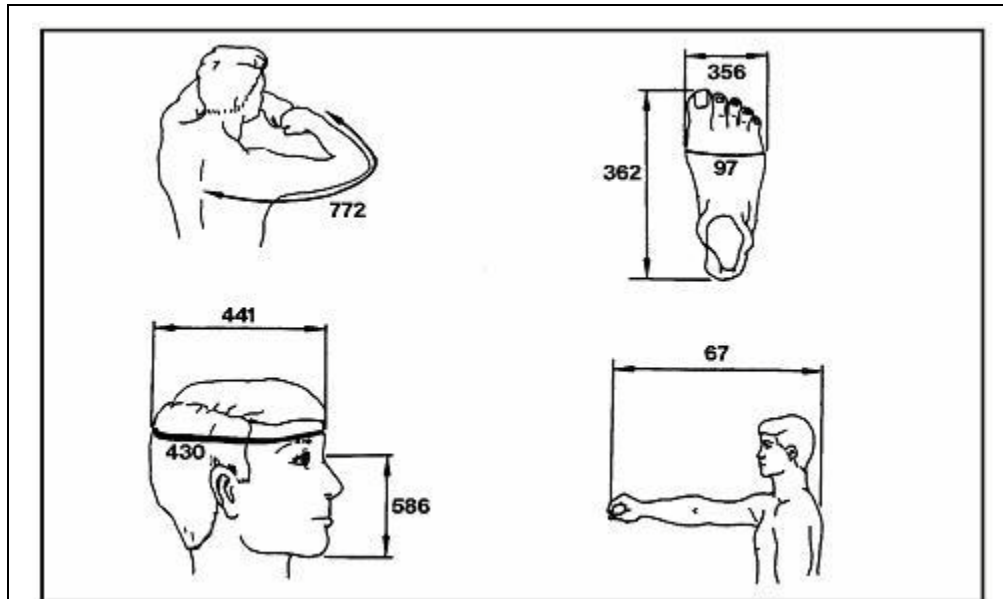


No.	Dimension	Min (cm [in])	Max (cm [in])
747	Shoulder circumference	90.4 (35.6)	133.9 (52.7)
230	Chest circumference	75.7 (29.8)	118.6 (46.7)
931	Waist circumference	61.2 (24.1)	110.5 (43.5)
852	Thigh circumference	47.8 (18.8)	71.9 (28.3)
515	Knee circumference	30.7 (12.1)	44.5 (17.5)
207	Calf circumference	29.5 (11.6)	44.5 (17.5)
967	Wrist circumference	13.5 (5.3)	19.8 (7.8)
111	Biceps circumference, flexed	22.9 (9.0)	40.4 (15.9)
369	Forearm circumference, flexed	21.6 (8.5)	35.3 (13.9)



No.	Dimension	Min (cm [in])	Max (cm [in])
951	Waist height, sitting	19.3 (7.6)	27.2 (10.7)
797	Span, sitting	147.8 (58.2)	204.7 (80.6)
914	Vertical index fingertip reach, sitting	118.9 (46.8)	158.2 (62.3)

ANTHROPOMETRIC DIMENSIONAL DATA FOR AMERICAN FEMALE AND MALE (CONCLUDED)



No.	Dimension	Min (cm [in])	Max (cm [in])
67	Thumb-tip reach	65.0 (25.6)	90.9 (35.8)
772	Sleeve length	72.4 (28.5)	99.1 (39.0)
441	Head length	17.3 (6.8)	21.6 (8.5)
430	Head circumference	51.3 (20.2)	61.0 (24.0)
586	Menton-sellion (face) length	9.9 (3.9)	14.0 (5.5)
362	Foot length	21.6 (8.5)	30.5 (12.0)
356	Foot breadth	7.9 (3.1)	11.4 (4.5)
97	Ball of foot circumference	19.6 (7.7)	28.2 (11.1)

TABLE B1-2 - VEHICLE DESIGN CRITICAL ANTHROPOMETRY DIMENSIONS

Design Concern	Critical Dimension	Numerical Code from Table B1-1	Minimal Clothing		With ACES-Type Suit, Unpressurized		With ACES-Type Suit, Pressurized	
			Min (cm [in])	Max (cm [in])	Min (cm [in])	Max (cm [in])	Min (cm [in])	Max (cm [in])
Maximum vertical clearance	Stature, standing	805	148.6 (58.5)	194.6 (76.6)	157.7 (62.1)	203.7 (80.2)	158.0 (62.2)	200.2 (78.8)
Vertical seating clearance	Sitting height	758	77.7 (30.6)	101.3 (39.9)	83.6 (32.9)	112.8 (44.4)	85.9 (33.8)	110.7 (43.6)
Vertical seating clearance with bailer bar down or removed	Sitting height without bailer bar**	758	NA	NA	82.3 (32.4)	105.9 (41.7)	NA	NA
Placement of panels to be within line-of-sight	Eye height, sitting	330	66.5 (26.2)	88.9 (35.0)	61.2 (24.1)	87.6 (34.5)	56.9 (22.4)	84.8 (33.4)
Top of seatback	Acromial height, sitting	N/A	49.5 (19.5)	68.1 (26.8)	48.8 (19.2)	68.8 (27.1)	48.3(19.0)	68.3 (26.9)
Placement of objects that may be over lap (panels, control wheel, etc.)	Thigh clearance, sitting	856	13.0 (5.1)	20.1 (7.9)	15.0 (5.9)	19.8 (7.8)	17.5 (6.9)	21.6(8.5)
Height of panels in front of subject	Knee height, sitting	529	45.5 (17.9)	63.5 (25.0)	47.2 (18.6)	66.3 (26.1)	51.3 (20.2)	69.9 (27.5)
Height of seat pan	Popliteal height, sitting	678	33.0 (13.0)	50.0 (19.7)	31.8 (12.5)	51.1 (20.1)	32.0 (12.6)	49.0 (19.3)
Downward reach of subject	Wrist height, sitting (with arm to the side)	N/A	39.6 (15.6)	54.6 (21.5)	41.1 (16.2)	62.5 (24.6)	45.0 (17.7)	63.5 (25.0)
Placement of restraint straps	Biacromial breadth	103	32.3 (12.7)	44.5 (17.5)	36.1 (14.2)	45.5 (17.9)	34.8 (13.7)	47.8 (18.8)
Width of seatback	Bideltoid breadth	122	37.8 (14.9)	56.1 (22.1)	53.1 (20.9)	66.3 (26.1)	58.4 (23.0)	70.9 (27.9)
Width of seatback for conformal seat	Bideltoid breadth in conformal seat**	122	NA	NA	41.8 (16.5)	60.1 (23.7)	NA	NA
Side clearance envelope, possible seatback width	Forearm-forearm breadth	378	38.9 (15.3)	66.0 (26.0)	69.3 (27.3)	87.6 (34.5)	82.3 (32.4)	100.6 (39.6)
Side clearance envelope, possible seatback width for conformal seat	Forearm-forearm breadth in conformal seat**	378	NA	NA	48.9 (19.3)	76.0 (29.9)	NA	NA
Width of seat pan	Hip breadth, sitting	459*	31.5 (12.4)	46.5 (18.3)	36.3 (14.3)	54.4 (21.4)	38.9 (15.3)	55.6 (21.9)

Revision: E	Document No: CxP 70024
Release Date: 11/19/10	Page: 335 of 503
Title: Constellation Program Human-Systems Integration Requirements	

TABLE B1-3 - VEHICLE DESIGN CRITICAL ANTHROPOMETRY DIMENSIONS (CONCLUDED)

Design Concern	Critical Dimension	Numerical Code from Table B1-1	Minimal Clothing		With ACES-Type Suit, Unpressurized		With ACES-Type Suit, Pressurized	
			Min (cm [in])	Max (cm [in])	Min (cm [in])	Max (cm [in])	Min (cm [in])	Max (cm [in])
Width of seat pan for conformal seat	Hip breadth, sitting in conformal seat**	459*	NA	NA	32.8 (12.9)	48.8 (19.2)	NA	NA
Length of seat pan	Buttock-popliteal length, sitting	200	42.2 (16.6)	57.2 (22.5)	47.2 (18.6)	62.2 (24.5)	50.0 (19.7)	68.6 (27.0)
Placement of panels in front of subject	Buttock-knee length, sitting	194	52.1 (20.5)	69.9 (27.5)	59.9 (23.6)	73.9 (29.1)	66.3 (26.1)	82.0 (32.3)
Rudder pedal design, foot clearance	Foot length, sitting	362	21.6 (8.5)	30.5 (12.0)	27.2 (10.7)	38.6 (15.2)	27.2 (10.7)	38.6 (15.2)
Placement of control panels, maximum reach	Thumb tip reach, sitting	67	65.0 (25.6)	90.9 (35.8)	67.3 (26.5)	103.1 (40.6)	52.8 (20.8)	100.6 (39.6)

* For seated measurements, the largest female hip breadth is larger than the largest male hip breadth, and the smallest male hip breadth is smaller than the smallest female hip breadth; therefore, male data are used for the Min dimension, and female data are used for the Max dimension.

** Additional measurements are provided for specific hardware assumptions. These measurements were taken with a bailer bar either in a down position or removed, in a conformal-style seat that includes features such as a reduced angle between the hip and torso as well as shoulder bolsters. Measurements were taken only in the unpressurized suit condition. Because measurements for these hardware configurations are not provided for unsuited or pressurized suited conditions, the standard hardware configuration measurement should always be used for those suit conditions. More details pertaining to measurement assumptions may be found in Memo ZF-08-004: Application of HS2002 Anthropometric Critical Dimensions and Table B1-7 to Occupant Protection and Landing Strategy Tiger Teams.

Revision: E	Document No: CxP 70024
Release Date: 11/19/10	Page: 336 of 503
Title: Constellation Program Human-Systems Integration Requirements	

The data provided in table Vehicle Design Critical Anthropometry Dimensions are based on measurements taken of subjects before and after donning an ACES suit. Compared to table Visual Index for Critical Anthropometric Dimensions, greater changes in stature occur for larger individuals than for smaller individuals. This is due in part to differences in suit fit between small and large crewmembers. The adjustment to account for a suit is not additive; rather, a subject's unsuited height is multiplied by a factor based on data collected during testing. Differences between effects of ACES and effects of other suits are likely to exist, but the numbers provided in table Vehicle Design Critical Anthropometry Dimensions are derived from laboratory measurements. Neither the data in table Anthropometric Dimensional Data for American Female and Male nor table Vehicle Design Critical Anthropometry Dimensions account for clearances for operational movements crewmembers routinely perform while suited, e.g., helmet removal.

TABLE B1-4 - SUIT DESIGN CRITICAL ANTHROPOMETRY DIMENSIONS

Design Concern	Critical Dimension	Numerical Code from Table B1-1	Minimal Clothing	
			Min (cm [in])	Max (cm [in])
Maximum vertical clearance	Stature, standing	805	148.6 (58.5)	194.6 (76.6)
Placement of headrest	Vertical trunk diameter	N/A	55.9 (22.0)	75.9 (29.9)
Leg length	Crotch height	249	66.5 (26.2)	95.8 (37.7)
Knee break	Knee height mid-patella	873	39.6 (15.6)	57.9 (22.8)
Torso sizing	Chest breadth	223	23.6 (9.3)	39.4 (15.5)
Torso sizing	Chest depth	236	19.1 (7.5)	30.2 (11.9)
Neck ring and helmet sizing	Head length	441	17.3 (6.8)	21.6 (8.5)
Maximum circumference of upper leg	Thigh circumference	852	47.8 (18.8)	71.9 (28.3)
Maximum circumference of upper arm	Biceps circumference flexed	111	22.9 (9.0)	40.4 (15.9)
Torso sizing	Chest circumference	230	75.7 (29.8)	118.6 (46.7)
Arm sizing	Inter-wrist distance	N/A	115.1 (45.3)	161.8 (63.7)
Functional arm break, arm length	Inter-elbow distance	N/A	72.6 (28.6)	101.3 (39.9)
Lower torso sizing	Waist depth	N/A	15.0 (5.9)	30.0 (11.8)
Lower torso sizing	Hip breadth	457*	29.7 (11.7)	40.6 (16.0)
Arm sizing	Wrist-to-wall distance	N/A	54.6 (21.5)	77.7 (30.6)

*For standing measurements, the largest female hip breadth is larger than the largest male hip breadth; therefore, female data are used for both the Min dimension and the Max dimension.

Revision: E	Document No: CxP 70024
Release Date: 11/19/10	Page: 337 of 503
Title: Constellation Program Human-Systems Integration Requirements	

B2.0 RANGE OF MOTION

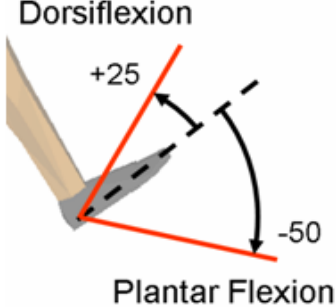
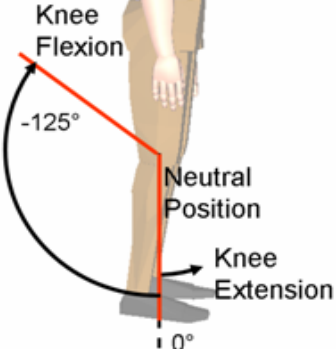

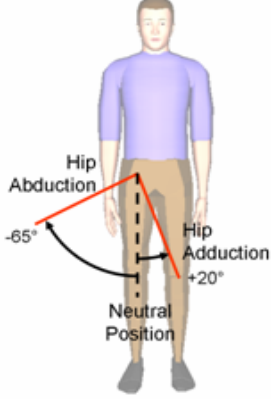
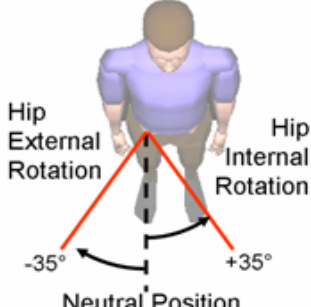
The ranges of motion to be accommodated for crewmembers (shown in Appendix B, tables Unsuiting Joint Mobility, Unpressurized-Suited Joint Mobility, and Pressurized Suited Joint Mobility for Nominal Pressure Microgravity Operations) were collected in 1 g under a variety of suited and unsuited conditions as part of a 2007/2008 study in the NASA JSC Anthropometry and Biomechanics Facility. The range of motion numbers present in these tables show the level of mobility that was needed to perform a variety of relevant functional tasks. These numbers do not necessarily indicate maximum level of mobility possible in a given configuration. Each table (Unsuited Joint Mobility, Unpressurized-Suited Joint Mobility, and Pressurized Suited Joint Mobility for Nominal Pressure Microgravity Operations) provides the range of motion for specific suited and gravitational conditions as described below.

Table Unsuiting Joint Mobility presents unsuited mobility requirements for design of vehicle components with which an unsuited crewmember will be expected to interact. This table also contains several joint measures that were present in old versions of this table but were not reinvestigated as a part of the 2007/2008 mobility study. These values are located at the end of the table and are identified with an asterisk.

Table Unpressurized-Suited Joint Mobility presents unpressurized-suited mobility requirements for design of components such as cockpit controls, seat restraints, seat stowage, and all other interfaces used by a crewmember wearing a suit that is not actively pressurized.

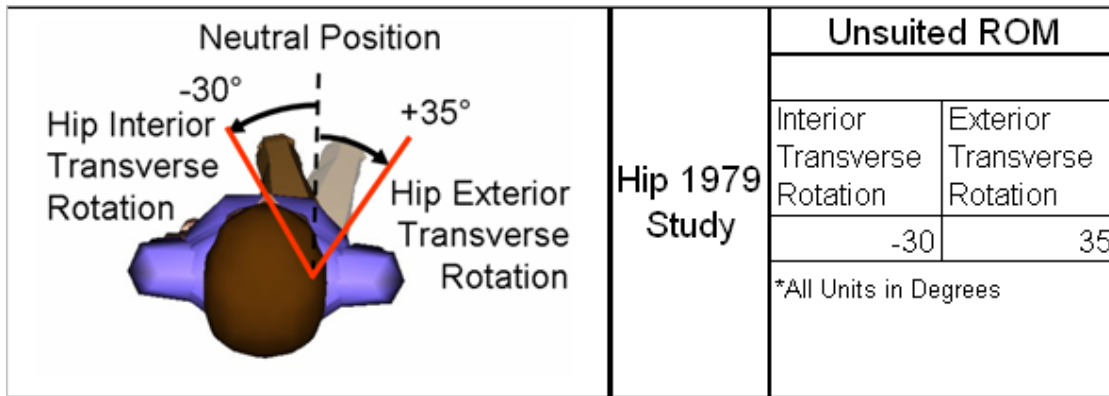
Table Pressurized Suited Joint Mobility for Nominal Pressure Microgravity Operations presents pressurized-suited mobility requirements for design of components with which a crewmember will be expected to interact when in any pressurized-suited state for nominal pressure microgravity operations.

TABLE B2-1 - UNSUITED JOINT MOBILITY

 <p>Dorsiflexion +25</p> <p>Plantar Flexion -50</p>	<p>Ankle</p>	<table border="1"> <tr> <th colspan="2">Unsuited ROM</th> </tr> <tr> <td>Dorsiflexion</td> <td>Plantar Flex</td> </tr> <tr> <td>25</td> <td>-50</td> </tr> <tr> <td colspan="2">*All Units in Degrees</td> </tr> </table>	Unsuited ROM		Dorsiflexion	Plantar Flex	25	-50	*All Units in Degrees				
Unsuited ROM													
Dorsiflexion	Plantar Flex												
25	-50												
*All Units in Degrees													
 <p>Knee Flexion -125°</p> <p>Neutral Position</p> <p>Knee Extension 0°</p>	<p>Knee</p>	<table border="1"> <tr> <th colspan="2">Unsuited ROM</th> </tr> <tr> <td>Flexion</td> <td>Extension</td> </tr> <tr> <td>-125</td> <td>0</td> </tr> <tr> <td colspan="2">*All Units in Degrees</td> </tr> </table>	Unsuited ROM		Flexion	Extension	-125	0	*All Units in Degrees				
Unsuited ROM													
Flexion	Extension												
-125	0												
*All Units in Degrees													
 <p>Hip Flexion +165°</p> <p>Hip Extension -15°</p> <p>Neutral Position 0°</p>	 <p>Hip Abduction -65°</p> <p>Hip Adduction +20°</p> <p>Neutral Position</p>	<p>Hip</p>	<table border="1"> <tr> <th colspan="2">Unsuited ROM</th> </tr> <tr> <td>Flexion</td> <td>Extension</td> </tr> <tr> <td>165</td> <td>-15</td> </tr> <tr> <td>Abduction</td> <td>Adduction</td> </tr> <tr> <td>-65</td> <td>20</td> </tr> </table>	Unsuited ROM		Flexion	Extension	165	-15	Abduction	Adduction	-65	20
Unsuited ROM													
Flexion	Extension												
165	-15												
Abduction	Adduction												
-65	20												
 <p>Hip External Rotation -35°</p> <p>Hip Internal Rotation +35°</p> <p>Neutral Position</p>		<table border="1"> <tr> <td>Int Rotation</td> <td>Ext Rotation</td> </tr> <tr> <td>35</td> <td>-35</td> </tr> <tr> <td colspan="2">*All Units in Degrees</td> </tr> </table>	Int Rotation	Ext Rotation	35	-35	*All Units in Degrees						
Int Rotation	Ext Rotation												
35	-35												
*All Units in Degrees													

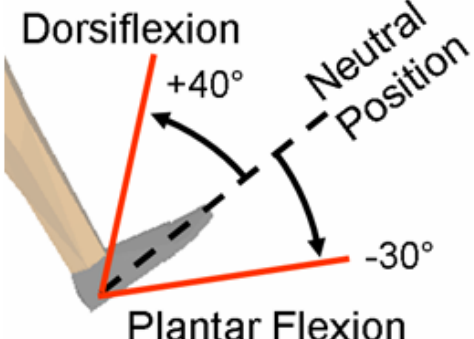
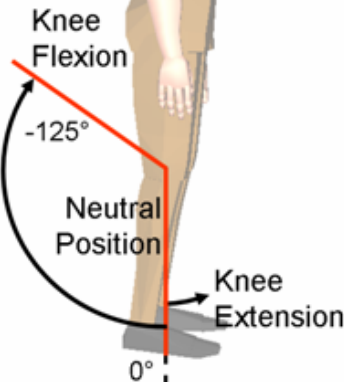
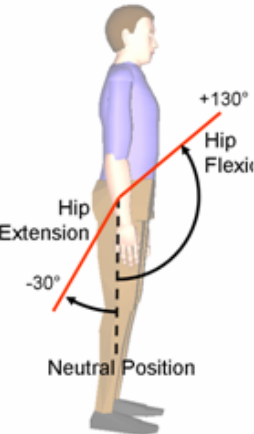
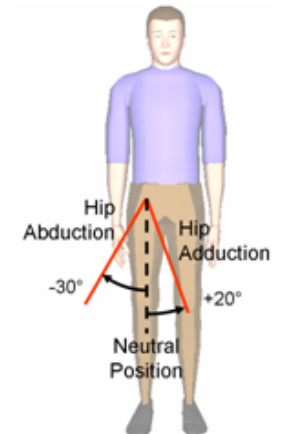
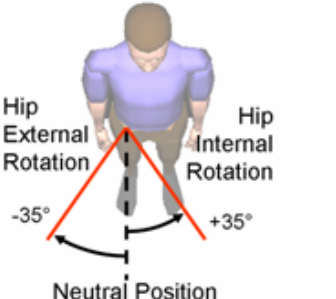
<p>Neutral Position +15° Torso Extension Torso Flexion -45°</p>	<p>Neutral Position Torso Right Lean +40° Torso Left Lean -40° 0°</p>	<p>Torso</p>	<table border="1"> <thead> <tr> <th colspan="2">Unsuited ROM</th> </tr> </thead> <tbody> <tr> <td>Flexion</td> <td>Extension</td> </tr> <tr> <td>-45</td> <td>15</td> </tr> <tr> <td>Right Lean</td> <td>Left Lean</td> </tr> <tr> <td>40</td> <td>-40</td> </tr> <tr> <td>CCW</td> <td>CW</td> </tr> <tr> <td>30</td> <td>-30</td> </tr> <tr> <td colspan="2">*All Units in Degrees</td> </tr> </tbody> </table>	Unsuited ROM		Flexion	Extension	-45	15	Right Lean	Left Lean	40	-40	CCW	CW	30	-30	*All Units in Degrees	
Unsuited ROM																			
Flexion	Extension																		
-45	15																		
Right Lean	Left Lean																		
40	-40																		
CCW	CW																		
30	-30																		
*All Units in Degrees																			
<p>Torso CW Rotation -30° Torso CCW Rotation +30° Neutral Position</p>		<table border="1"> <thead> <tr> <th colspan="2">Unsuited ROM</th> </tr> </thead> <tbody> <tr> <td>Flexion</td> <td>Extension</td> </tr> <tr> <td>145</td> <td>-70</td> </tr> <tr> <td>Abduction</td> <td>Adduction</td> </tr> <tr> <td>-165</td> <td>45</td> </tr> <tr> <td colspan="2">*All Units in Degrees</td> </tr> </tbody> </table>	Unsuited ROM		Flexion	Extension	145	-70	Abduction	Adduction	-165	45	*All Units in Degrees						
Unsuited ROM																			
Flexion	Extension																		
145	-70																		
Abduction	Adduction																		
-165	45																		
*All Units in Degrees																			
<p>Shoulder Extension -70° Neutral Position Shoulder Flexion +145°</p>	<p>Shoulder Abduction -165° Neutral Position Shoulder Adduction +45°</p>	<p>Shoulder</p>	<table border="1"> <thead> <tr> <th colspan="2">Unsuited ROM</th> </tr> </thead> <tbody> <tr> <td>Interior Transverse Rotation</td> <td>Exterior Transverse Rotation</td> </tr> <tr> <td>-45</td> <td>135</td> </tr> <tr> <td>Lateral</td> <td>Medial</td> </tr> <tr> <td>-46</td> <td>91</td> </tr> <tr> <td colspan="2">*All Units in Degrees</td> </tr> </tbody> </table>	Unsuited ROM		Interior Transverse Rotation	Exterior Transverse Rotation	-45	135	Lateral	Medial	-46	91	*All Units in Degrees					
Unsuited ROM																			
Interior Transverse Rotation	Exterior Transverse Rotation																		
-45	135																		
Lateral	Medial																		
-46	91																		
*All Units in Degrees																			
<p>Neutral Position Shoulder Interior Transverse Rotation -45° Shoulder Exterior Transverse Rotation +135° Shoulder Rotation Lateral -46° Shoulder Rotation Medial +91°</p>		<p>Shoulder 1979 Study</p>																	

<p>Elbow Flexion +130° Neutral Position 0° Elbow Extension</p>	<p>Elbow</p>	<table border="1"> <tr> <th colspan="2">Unsuited ROM</th> </tr> <tr> <td>Flexion</td> <td>Extension</td> </tr> <tr> <td>130</td> <td>0</td> </tr> <tr> <td colspan="2">*All Units in Degrees</td> </tr> </table>	Unsuited ROM		Flexion	Extension	130	0	*All Units in Degrees									
Unsuited ROM																		
Flexion	Extension																	
130	0																	
*All Units in Degrees																		
<p>Wrist Extension -90° Neutral Position Wrist Flexion +60°</p>	<p>Wrist Supination -80° Neutral Position Wrist Pronation +80°</p>	<table border="1"> <tr> <th colspan="2">Unsuited ROM</th> </tr> <tr> <td>Extension</td> <td>Flexion</td> </tr> <tr> <td>-90</td> <td>60</td> </tr> <tr> <td>Abduction (Radial Deviation)</td> <td>Adduction (Ulnar Deviation)</td> </tr> <tr> <td>30</td> <td>-25</td> </tr> <tr> <td>Supination</td> <td>Pronation</td> </tr> <tr> <td>-80</td> <td>80</td> </tr> <tr> <td colspan="2">*All Units in Degrees</td> </tr> </table>	Unsuited ROM		Extension	Flexion	-90	60	Abduction (Radial Deviation)	Adduction (Ulnar Deviation)	30	-25	Supination	Pronation	-80	80	*All Units in Degrees	
Unsuited ROM																		
Extension	Flexion																	
-90	60																	
Abduction (Radial Deviation)	Adduction (Ulnar Deviation)																	
30	-25																	
Supination	Pronation																	
-80	80																	
*All Units in Degrees																		
<p>Wrist Adduction -25° Neutral Position Wrist Abduction +30°</p>	<p>Neck 1979 Study</p>	<table border="1"> <tr> <th colspan="2">Unsuited ROM</th> </tr> <tr> <td>Flex</td> <td>Ex</td> </tr> <tr> <td>-65</td> <td>34</td> </tr> <tr> <td>Bend Right</td> <td>Bend Left</td> </tr> <tr> <td>-35</td> <td>29</td> </tr> <tr> <td>Rot R</td> <td>Rot L</td> </tr> <tr> <td>-73</td> <td>72</td> </tr> <tr> <td colspan="2">*All Units in Degrees</td> </tr> </table>	Unsuited ROM		Flex	Ex	-65	34	Bend Right	Bend Left	-35	29	Rot R	Rot L	-73	72	*All Units in Degrees	
Unsuited ROM																		
Flex	Ex																	
-65	34																	
Bend Right	Bend Left																	
-35	29																	
Rot R	Rot L																	
-73	72																	
*All Units in Degrees																		
<p>Neutral Position +34° -65° Neck Flexion Neck Extension</p>	<p>Neutral Position -35° +29° Neck lateral bend right Neck lateral bend left</p>																	
<p>Neck Rotation Right -73° Neutral Position Neck Rotation Left +72°</p>																		



“1979 Study” refers to data from SP-2-86L-064 Thornton, W, and Jackson, J. Anthropometric Study of Astronaut Candidates, 1979 to 1980, (Unpublished Data) NASA-JSC.

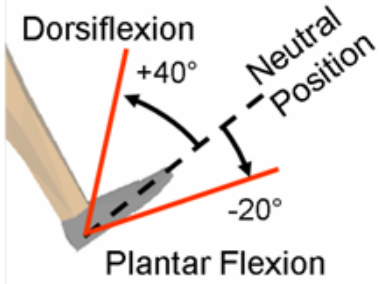
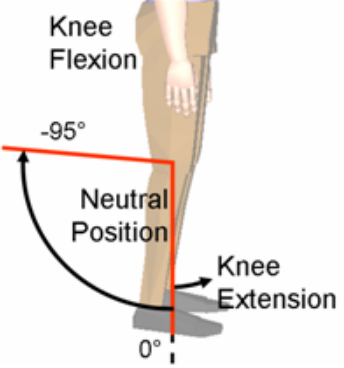
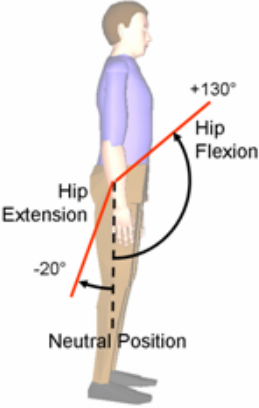
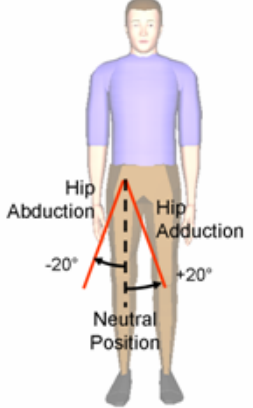
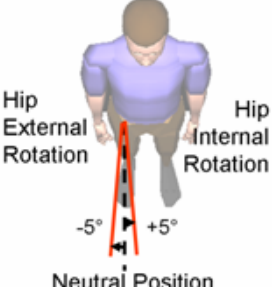
TABLE B2-2 - UNPRESSURIZED SUITED JOINT MOBILITY

 <p>Dorsiflexion +40° Neutral Position Plantar Flexion -30°</p>	Ankle	Suited Unpressurized ROM	
		Dorsiflexion	Plantar Flex
40		-30	
*All Units in Degrees			
 <p>Knee Flexion -125° Neutral Position Knee Extension 0°</p>	Knee	Suited Unpressurized ROM	
		Flexion	Extension
-125		0	
*All Units in Degrees			
 <p>Hip Flexion +130° Hip Extension -30° Neutral Position</p>	 <p>Hip Abduction -30° Hip Adduction +20° Neutral Position</p>	Suited Unpressurized ROM	
		Flexion	Extension
130		-30	
		Abduction	Adduction
-30		20	
 <p>Hip External Rotation -35° Hip Internal Rotation +35° Neutral Position</p>	Hip	Int Rotation	Ext Rotation
35		-35	
*All Units in Degrees			

<p>Neutral Position +15° Torso Extension -45° Torso Flexion</p>	<p>Neutral Position Torso Right Lean +25° Torso Left Lean -25°</p>	<p>Torso</p>	<table border="1"> <thead> <tr> <th colspan="2">Suited Unpressurized ROM</th> </tr> </thead> <tbody> <tr> <td>Flexion</td> <td>Extension</td> </tr> <tr> <td>-45</td> <td>15</td> </tr> <tr> <td>Right Lean</td> <td>Left Lean</td> </tr> <tr> <td>25</td> <td>-25</td> </tr> <tr> <td>CCW</td> <td>CW</td> </tr> <tr> <td>30</td> <td>-30</td> </tr> <tr> <td colspan="2">*All Units in Degrees</td> </tr> </tbody> </table>	Suited Unpressurized ROM		Flexion	Extension	-45	15	Right Lean	Left Lean	25	-25	CCW	CW	30	-30	*All Units in Degrees	
Suited Unpressurized ROM																			
Flexion	Extension																		
-45	15																		
Right Lean	Left Lean																		
25	-25																		
CCW	CW																		
30	-30																		
*All Units in Degrees																			
<p>Torso CW Rotation -30° Torso CCW Rotation +30° Neutral Position</p>		<table border="1"> <thead> <tr> <th colspan="2">Suited Unpressurized ROM</th> </tr> </thead> <tbody> <tr> <td>Flexion</td> <td>Extension</td> </tr> <tr> <td>140</td> <td>-60</td> </tr> <tr> <td>Ab</td> <td>Ad</td> </tr> <tr> <td>-120</td> <td>25</td> </tr> <tr> <td colspan="2">*All Units in Degrees</td> </tr> </tbody> </table>	Suited Unpressurized ROM		Flexion	Extension	140	-60	Ab	Ad	-120	25	*All Units in Degrees						
Suited Unpressurized ROM																			
Flexion	Extension																		
140	-60																		
Ab	Ad																		
-120	25																		
*All Units in Degrees																			
<p>+140° Shoulder Extension -60° Shoulder Flexion Neutral Position</p>	<p>Shoulder Abduction -120° +25° Shoulder Adduction Neutral Position</p>	<p>Shoulder</p>	<table border="1"> <thead> <tr> <th colspan="2">Suited Unpressurized ROM</th> </tr> </thead> <tbody> <tr> <td>Interior Transverse Rotation</td> <td>Exterior Transverse Rotation</td> </tr> <tr> <td>-25</td> <td>120</td> </tr> <tr> <td>Lateral</td> <td>Medial</td> </tr> <tr> <td>-25</td> <td>60</td> </tr> <tr> <td colspan="2">*All Units in Degrees</td> </tr> </tbody> </table>	Suited Unpressurized ROM		Interior Transverse Rotation	Exterior Transverse Rotation	-25	120	Lateral	Medial	-25	60	*All Units in Degrees					
Suited Unpressurized ROM																			
Interior Transverse Rotation	Exterior Transverse Rotation																		
-25	120																		
Lateral	Medial																		
-25	60																		
*All Units in Degrees																			
<p>Neutral Position Shoulder Interior Transverse Rotation -25° Shoulder Exterior Transverse Rotation 120°</p> <p>Neutral Position Shoulder Rotation Lateral -25° Shoulder Rotation Medial 60°</p>		<p>Add'l Shoulder</p>																	

	<p style="text-align: center;">Elbow</p>	<table border="1"> <tr> <th colspan="2">Suited Unpressurized ROM</th> </tr> <tr> <td>Flexion</td> <td>Extension</td> </tr> <tr> <td style="text-align: center;">110</td> <td style="text-align: center;">0</td> </tr> <tr> <td colspan="2">*All Units in Degrees</td> </tr> </table>	Suited Unpressurized ROM		Flexion	Extension	110	0	*All Units in Degrees			
Suited Unpressurized ROM												
Flexion	Extension											
110	0											
*All Units in Degrees												
		<table border="1"> <tr> <th colspan="2">Suited Unpressurized ROM</th> </tr> <tr> <td>Extension</td> <td>Flexion</td> </tr> <tr> <td style="text-align: center;">-90</td> <td style="text-align: center;">50</td> </tr> <tr> <td>Abduction (Radial Deviation)</td> <td>Adduction (Ulnar Deviation)</td> </tr> <tr> <td style="text-align: center;">30</td> <td style="text-align: center;">-30</td> </tr> </table>	Suited Unpressurized ROM		Extension	Flexion	-90	50	Abduction (Radial Deviation)	Adduction (Ulnar Deviation)	30	-30
Suited Unpressurized ROM												
Extension	Flexion											
-90	50											
Abduction (Radial Deviation)	Adduction (Ulnar Deviation)											
30	-30											
		<table border="1"> <tr> <td>Supination</td> <td>Pronation</td> </tr> <tr> <td style="text-align: center;">-80</td> <td style="text-align: center;">80</td> </tr> <tr> <td colspan="2">*All Units in Degrees</td> </tr> </table>	Supination	Pronation	-80	80	*All Units in Degrees					
Supination	Pronation											
-80	80											
*All Units in Degrees												

TABLE B2-3 - PRESSURIZED SUITED JOINT MOBILITY FOR NOMINAL PRESSURE
MICROGRAVITY OPERATIONS

	<p>Ankle</p>	<table border="1"> <tr> <th colspan="2">Suited Pressurized ROM</th> </tr> <tr> <td>Dorsiflexion</td> <td>Plantar Flex</td> </tr> <tr> <td>40</td> <td>-20</td> </tr> <tr> <td colspan="2">*All Units in Degrees</td> </tr> </table>	Suited Pressurized ROM		Dorsiflexion	Plantar Flex	40	-20	*All Units in Degrees				
Suited Pressurized ROM													
Dorsiflexion	Plantar Flex												
40	-20												
*All Units in Degrees													
	<p>Knee</p>	<table border="1"> <tr> <th colspan="2">Suited Pressurized ROM</th> </tr> <tr> <td>Flexion</td> <td>Extension</td> </tr> <tr> <td>-95</td> <td>0</td> </tr> <tr> <td colspan="2">*All Units in Degrees</td> </tr> </table>	Suited Pressurized ROM		Flexion	Extension	-95	0	*All Units in Degrees				
Suited Pressurized ROM													
Flexion	Extension												
-95	0												
*All Units in Degrees													
		<p>Hip</p>	<table border="1"> <tr> <th colspan="2">Suited Pressurized ROM</th> </tr> <tr> <td>Flexion</td> <td>Extension</td> </tr> <tr> <td>130</td> <td>-20</td> </tr> <tr> <td>Abduction</td> <td>Adduction</td> </tr> <tr> <td>-20</td> <td>20</td> </tr> </table>	Suited Pressurized ROM		Flexion	Extension	130	-20	Abduction	Adduction	-20	20
Suited Pressurized ROM													
Flexion	Extension												
130	-20												
Abduction	Adduction												
-20	20												
			<table border="1"> <tr> <td>Int Rotation</td> <td>Ext Rotation</td> </tr> <tr> <td>5</td> <td>-5</td> </tr> <tr> <td colspan="2">*All Units in Degrees</td> </tr> </table>	Int Rotation	Ext Rotation	5	-5	*All Units in Degrees					
Int Rotation	Ext Rotation												
5	-5												
*All Units in Degrees													

		<p style="text-align: center;">Torso</p>	<table border="1"> <thead> <tr> <th colspan="2">Suited Pressurized ROM</th> </tr> </thead> <tbody> <tr> <td>Flexion</td> <td>Extension</td> </tr> <tr> <td style="text-align: center;">0</td> <td style="text-align: center;">0</td> </tr> <tr> <td>Right Lean</td> <td>Left Lean</td> </tr> <tr> <td style="text-align: center;">0</td> <td style="text-align: center;">0</td> </tr> <tr> <td>CCW</td> <td>CW</td> </tr> <tr> <td style="text-align: center;">0</td> <td style="text-align: center;">0</td> </tr> <tr> <td colspan="2">*All Units in Degrees</td> </tr> </tbody> </table>	Suited Pressurized ROM		Flexion	Extension	0	0	Right Lean	Left Lean	0	0	CCW	CW	0	0	*All Units in Degrees	
Suited Pressurized ROM																			
Flexion	Extension																		
0	0																		
Right Lean	Left Lean																		
0	0																		
CCW	CW																		
0	0																		
*All Units in Degrees																			
		<table border="1"> <thead> <tr> <th colspan="2">Suited Pressurized ROM</th> </tr> </thead> <tbody> <tr> <td>Flexion</td> <td>Extension</td> </tr> <tr> <td style="text-align: center;">115</td> <td style="text-align: center;">-10</td> </tr> <tr> <td>Abduction</td> <td>Adduction</td> </tr> <tr> <td style="text-align: center;">-110</td> <td style="text-align: center;">0</td> </tr> <tr> <td colspan="2">*All Units in Degrees</td> </tr> </tbody> </table>	Suited Pressurized ROM		Flexion	Extension	115	-10	Abduction	Adduction	-110	0	*All Units in Degrees						
Suited Pressurized ROM																			
Flexion	Extension																		
115	-10																		
Abduction	Adduction																		
-110	0																		
*All Units in Degrees																			
		<p style="text-align: center;">Shoulder</p>	<table border="1"> <thead> <tr> <th colspan="2">Suited Pressurized ROM</th> </tr> </thead> <tbody> <tr> <td>Interior Transverse Rotation</td> <td>Exterior Transverse Rotation</td> </tr> <tr> <td style="text-align: center;">0</td> <td style="text-align: center;">120</td> </tr> <tr> <td>Lateral</td> <td>Medial</td> </tr> <tr> <td style="text-align: center;">-25</td> <td style="text-align: center;">60</td> </tr> <tr> <td colspan="2">*All Units in Degrees</td> </tr> </tbody> </table>	Suited Pressurized ROM		Interior Transverse Rotation	Exterior Transverse Rotation	0	120	Lateral	Medial	-25	60	*All Units in Degrees					
Suited Pressurized ROM																			
Interior Transverse Rotation	Exterior Transverse Rotation																		
0	120																		
Lateral	Medial																		
-25	60																		
*All Units in Degrees																			
		<p style="text-align: center;">Add'l Shoulder</p>																	

	<p style="text-align: center;">Elbow</p>	<p style="text-align: center;">Suited Pressurized ROM</p> <table border="1"> <tr> <td>Flexion</td> <td>Extension</td> </tr> <tr> <td style="text-align: center;">120</td> <td style="text-align: center;">0</td> </tr> <tr> <td colspan="2">*All Units in Degrees</td> </tr> </table>	Flexion	Extension	120	0	*All Units in Degrees					
Flexion		Extension										
120	0											
*All Units in Degrees												
		<p style="text-align: center;">Suited Pressurized ROM</p> <table border="1"> <tr> <td>Extension</td> <td>Flexion</td> </tr> <tr> <td style="text-align: center;">-60</td> <td style="text-align: center;">50</td> </tr> <tr> <td>Abduction (Radial Deviation)</td> <td>Adduction (Ulnar Deviation)</td> </tr> <tr> <td style="text-align: center;">25</td> <td style="text-align: center;">-25</td> </tr> <tr> <td colspan="2">*All Units in Degrees</td> </tr> </table>	Extension	Flexion	-60	50	Abduction (Radial Deviation)	Adduction (Ulnar Deviation)	25	-25	*All Units in Degrees	
Extension		Flexion										
-60	50											
Abduction (Radial Deviation)	Adduction (Ulnar Deviation)											
25	-25											
*All Units in Degrees												
	<p style="text-align: center;">Wrist</p>	<table border="1"> <tr> <td>Supination</td> <td>Pronation</td> </tr> <tr> <td style="text-align: center;">-80</td> <td style="text-align: center;">80</td> </tr> <tr> <td colspan="2">*All Units in Degrees</td> </tr> </table>	Supination	Pronation	-80	80	*All Units in Degrees					
Supination		Pronation										
-80	80											
*All Units in Degrees												

B3.0 MASS PROPERTIES

Crewmember whole-body mass, body-segment mass, center of mass location, and moment of inertia data are provided in the Appendix B tables within the section Segment Moments of Inertia.

The anatomical axis system is based on skeletal landmarks and provides a consistent reference for the principal axes system and the center of volume/mass independent of body-segment orientation as described in McConville et al. (1980) and Young et al. (1983). The principal axis of inertia originates at the center of volume/mass.

Regression equations from McConville et al. (1980) and Young et al. (1983) were used to compute the Body-Segment Properties (BSP); however, because the sample sizes in

Revision: E	Document No: CxP 70024
Release Date: 11/19/10	Page: 348 of 503
Title: Constellation Program Human-Systems Integration Requirements	

these two studies were relatively small (31 and 46 subjects, respectively), this document uses data from the ANSUR database for input into the regression equations.

The regression equations from the McConville et al. (1980) and Young et al. (1983) studies were used in their most simple form, which uses only the stature and weight of the subject to calculate the volume and moments of inertia. A Matlab code was written to identify all females with a small stature (based on the female data only) and all males with a large stature (based on the male data only) in the ANSUR database; from this extracted data, the lightest female and heaviest male were identified. These values were then used in the regression equations to compute the BSP. McConville and Young did not generate regression equations to predict all BSP presented in this report; however, presented below is a description and reasoning (based on the available data) of how each BSP presented here was generated.

For tables Whole-Body Mass of Crewmember, Body-Segment Mass Properties for the Male and Female Crewmember, and Whole-Body Center of Mass Location of the Male and Female Crewmember, minimum values correspond to a small female in mass, and maximum values correspond to a large male in mass, respectively. These values are considered to be representative of those for a small female and a large male crewmember, respectively.

Whole-Body Mass

Regressions equations from the McConville et al. (1980) and Young et al. (1983) studies were used to compute the whole-body volume. Whole-body mass was calculated by assuming the density of the human flesh was homogeneous; a density value of 1 g/cm^3 was used. With a value of unity for the density, the mass values are numerically equal to their corresponding volume values.

Whole Body Center of Mass

Assuming that the human flesh was homogeneous, it can also be assumed that the center of volume is at the center of mass location. McConville et al. (1980) and Young et al. (1983) provided ranges for the location of the center of volume for the male and female, respectively, in each study. Because regression equations were not given for the center of volume, the range values from the McConville et al. (1980) and Young et al. (1983) studies were used here. Specific values for the locations of the center of mass with respect to the anatomical axes were taken from each study to form the range; specifically, the upper range was set by the male upper range, and the lower range was set by the female lower range.

Whole Body Moments of Inertia

Moments of inertia regression equations from the McConville et al. (1980) and Young et al. (1983) studies were used.

Segment Mass

Revision: E	Document No: CxP 70024
Release Date: 11/19/10	Page: 349 of 503
Title: Constellation Program Human-Systems Integration Requirements	

Regressions equations from the McConville et al. (1980) and Young et al. (1983) studies were used to compute the segment volume. Segment mass was calculated by assuming the density of the human flesh was homogeneous; a density value of 1 g/cm³ was used. With a value of unity for the density, the mass values are numerically equal to their corresponding volume values.

Segment Center of Mass

Assuming that the human flesh was homogeneous, it can also be assumed that the center of volume is at the center of mass location. McConville et al. (1980) and Young et al. (1983) provided ranges for the location of the center of volume for the male and female, respectively, in each study. Because regression equations were not given for the center of volume, the range values from the McConville et al. (1980) and Young et al. (1983) studies were used in this update. Specific values for the locations of the center of mass with respect to the anatomical axes were taken from each study to form the range; specifically, the upper range was set by the male upper range, and the lower range was set by the female lower range.

Segment Moments of Inertia

Regression equations from the McConville et al. (1980) and Young et al. (1983) studies were used to compute the moments of inertia. The moments of inertia presented are those about the principal axes Xp, Yp, and Zp.

TABLE B3-1 - WHOLE-BODY MASS OF CREWMEMBER

Crewmember Body Mass (kg [lb])		
	Unsuited	Suited*
Min	42.64 (94)	78.93 (174)
Max	110.22 (243)	146.51 (323)
*The crewmember body mass for "Suited" includes 36.29 kg (80 lb) for the pressure garment and does not include crew survival gear or EVA gear. Data are projected forward to 2015.		

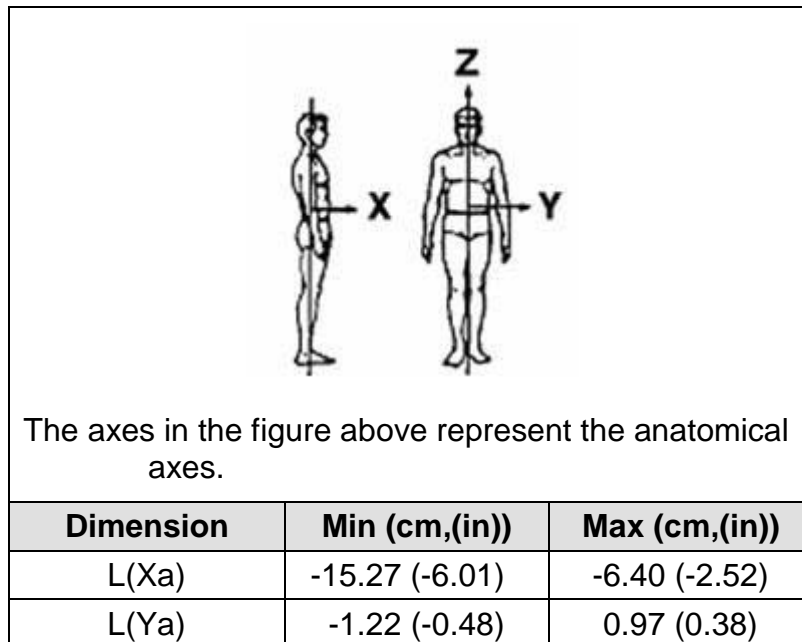
TABLE B3-2 - BODY-SEGMENT MASS PROPERTIES FOR THE MALE AND FEMALE CREWMEMBER

	Segment	Mass (kg [lb])	
		Min	Max
	1 Head	2.99 (6.59)	5.03 (11.08)
	2 Neck	0.49 (1.08)	1.39 (3.07)

	3 Thorax	11.35 (25.02)	34.33 (75.69)
	4 Abdomen	2.14 (4.72)	3.25 (7.16)
	5 Pelvis	5.62 (12.4)	16.46 (36.29)
	6 Upper arm	0.91 (2.0)	2.74 (6.04)
	7 Forearm	0.59 (1.29)	1.86 (4.09)
	8 Hand	0.24 (0.52)	0.66 (1.45)
	9 Hip flap	2.22 (4.9)	4.79 (10.55)
	10 Thigh minus hip flap	3.86 (8.12)	8.48 (18.69)
	11 Calf	1.94 (4.28)	5.11 (11.27)
	12 Foot	0.44 (0.98)	1.26 (2.77)
	Torso (5 + 4 + 3)	19.11 (42.13)	54.05 (119.15)
	Thigh (9 + 10)	5.91 (13.03)	13.26 (29.24)
	Forearm plus hand (7+8)	0.82 (1.81)	2.51 (5.54)

Data are projected forward to 2015.

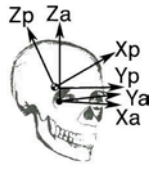
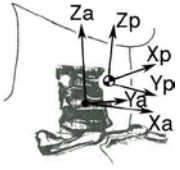
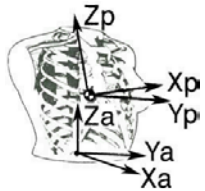
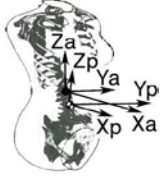
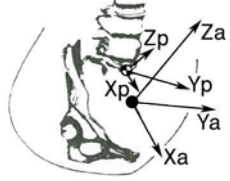
TABLE B3-3 - WHOLE-BODY CENTER OF MASS LOCATION OF THE MALE AND FEMALE CREWMEMBER

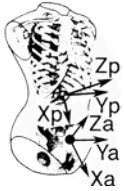
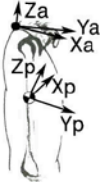
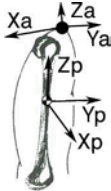
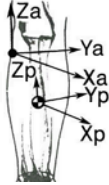


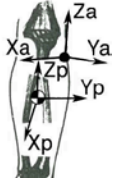
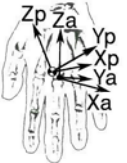

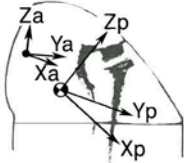
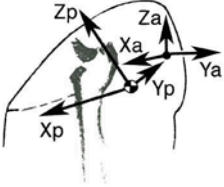
Revision: E	Document No: CxP 70024
Release Date: 11/19/10	Page: 351 of 503
Title: Constellation Program Human-Systems Integration Requirements	

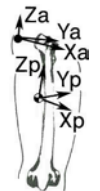
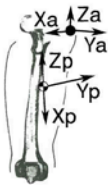
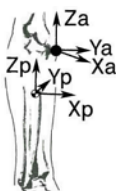
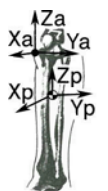

L(Za)	-3.81 (-1.5)	8.15 (3.21)
-------	--------------	-------------

TABLE B3-4 - BODY-SEGMENT CENTER OF MASS LOCATION OF THE CREWMEMBER

Segment	Anatomical Axis	Min (cm [in])	Max (cm [in])
Head 	Xa	-2.44 (-0.96)	0.53 (0.21)
	Ya	-0.61 (-0.24)	0.61 (0.24)
	Za	2.24 (0.88)	4.04 (1.59)
Neck 	Xa	3.40 (1.34)	7.32 (2.88)
	Ya	-0.56 (-0.22)	0.58 (0.23)
	Za	2.92 (1.15)	6.05 (2.38)
Thorax 	Xa	3.76 (1.48)	7.06 (2.78)
	Ya	-0.81 (-0.32)	0.48 (0.19)
	Za	13.44 (5.29)	21.97 (8.65)
Abdomen 	Xa	-1.47 (-0.58)	1.55 (0.61)
	Ya	-1.65 (-0.65)	2.26 (0.89)
	Za	-4.85 (-1.91)	-1.14 (-0.45)
Pelvis 	Xa	-12.17 (-4.79)	-6.96(-2.74)
	Ya	-1.32 (-0.52)	0.74 (0.29)
	Za	-0.76 (-0.30)	5.18 (2.04)
Torso	Xa	-10.41 (-4.1)	2.49 (0.98)

Segment	Anatomical Axis	Min (cm [in])	Max (cm [in])
	Ya	-1.52 (-0.60)	1.73 (0.68)
	Za	16.33 (6.43)	25.60 (10.08)
Right upper arm 	Xa	-0.71 (-0.28)	-0.91 (-0.36)
	Ya	1.85 (0.73)	-2.29 (-0.90)
	Za	-18.59 (-7.32)	-14.27 (-5.62)
Left upper arm 	Xa	-0.64 (-0.25)	2.59 (1.02)
	Ya	-3.68 (-1.45)	-1.80 (-0.71)
	Za	-18.72 (-7.37)	-14.33 (-5.64)
Right forearm 	Xa	1.02 (0.40)	0.08 (0.03)
	Ya	-2.11 (-0.83)	4.14 (1.63)
	Za	-9.86 (-3.88)	-8.86 (-3.49)

Segment	Anatomical Axis	Min (cm [in])	Max (cm [in])
Left forearm 	Xa	1.17 (0.46)	0.13 (0.05)
	Ya	-0.23 (-0.09)	-2.44 (-0.96)
	Za	-9.86 (-3.88)	-9.07 (-3.57)
Right hand 	Xa	-0.53 (-0.21)	0.03 (0.01)
	Ya	0.43 (0.17)	0.13 (0.05)
	Za	0.71 (0.28)	1.93 (0.76)
Left hand 	Xa	-0.71 (-0.28)	-0.23 (-0.09)
	Ya	-1.35 (-0.53)	0.89 (0.35)
	Za	0.84 (0.33)	2.03 (0.80)
Right hip flap 	Xa	-7.77 (-3.06)	1.70 (0.67)
	Ya	5.66 (2.23)	7.37 (2.90)
	Za	-6.73 (-2.65)	-6.05 (-2.38)
Left hip flap 	Xa	-8.20 (-3.23)	2.41 (0.95)
	Ya	-10.67 (-4.2)	-5.18 (-2.04)
	Za	-6.96 (-2.74)	-6.20 (-2.44)

Segment	Anatomical Axis	Min (cm [in])	Max (cm [in])
Right thigh minus flap 	Xa	-3.28 (-1.29)	2.36 (0.93)
	Ya	5.18 (2.04)	8.38 (3.30)
	Za	-24.84 (-9.78)	-23.34 (-9.19)
Left thigh minus flap 	Xa	3.10 (1.22)	2.21 (0.87)
	Ya	-9.60 (-3.78)	-5.28 (-2.08)
	Za	-24.87 (-9.79)	-23.62 (-9.3)
Right calf 	Xa	-4.24 (-1.67)	-0.10 (-0.04)
	Ya	-6.38 (-2.51)	-4.85(-1.91)
	Za	-16.18 (-6.37)	-12.01 (-4.73)
Left calf 	Xa	-4.34 (-1.71)	0.69 (0.27)
	Ya	4.04 (1.59)	6.83 (2.69)
	Za	-16.00 (-6.30)	-12.32 (-4.85)
Right foot 	Xa	-8.51 (-3.35)	-6.63 (-2.61)
	Ya	-0.28 (-0.11)	0.43 (0.17)
	Za	0.46 (0.18)	-0.05 (-0.02)

BODY-SEGMENT CENTER OF MASS LOCATION OF THE CREWMEMBER (CONCLUDED)

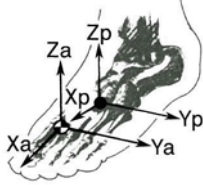
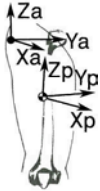
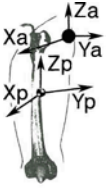
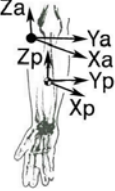

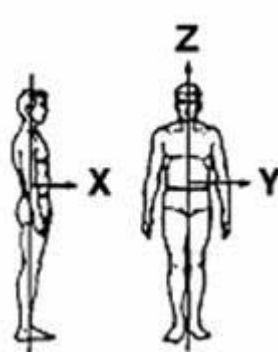
Segment	Anatomical Axis	Min (cm, ([in]))	Max (cm, ([in]))
Left foot 	Xa	-8.71 (-3.43)	-6.48 (-2.55)
	Ya	-0.86 (-0.34)	0.89 (0.35)
	Za	0.33 (0.13)	-0.10 (-0.04)
Right thigh 	Xa	-4.88 (-1.92)	2.11 (0.83)
	Ya	5.64 (2.22)	8.00 (3.15)
	Za	-17.55 (-6.91)	-17.55 (-6.91)
Left thigh 	Xa	-4.75 (-1.87)	2.29 (0.90)
	Ya	-9.65 (-3.80)	-5.26 (-2.07)
	Za	-17.91 (-7.05)	-17.83 (-7.02)
Right forearm plus hand 	Xa	0.43 (0.17)	-0.36 (-0.14)
	Ya	-2.29 (-0.90)	4.52 (1.78)
	Za	-15.54 (-6.12)	-14.99 (-5.9)
Left forearm plus hand 	Xa	0.43 (0.17)	0
	Ya	0.79 (0.31)	-2.82 (-1.11)
	Za	-15.37 (-6.05)	15.01 (-5.91)

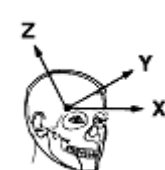
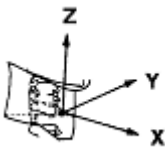
TABLE B3-5 - WHOLE-BODY MOMENT OF INERTIA OF THE CREWMEMBER

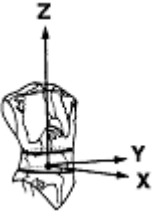
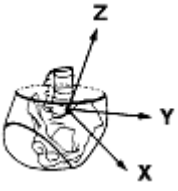
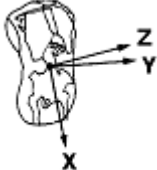



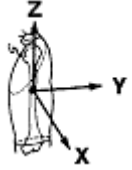
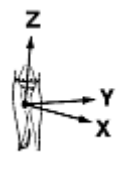


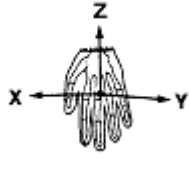
The axes in the figure above represent the principal axes.



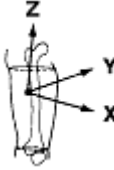
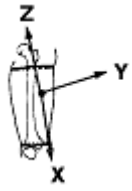
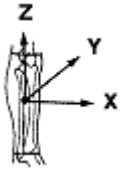
Axis	Min (kg·m ² [lb·ft ²])	Max (kg·m ² [lb·ft ²])
Xp	6.59 (156.38)	17.69 (419.79)
Yp	6.12 (145.23)	16.43 (389.89)
Zp	0.73 (17.32)	2.05 (48.65)

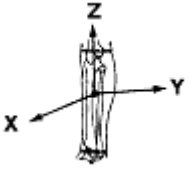
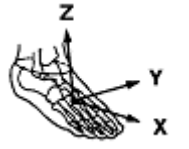

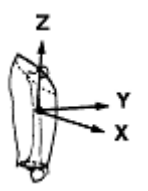

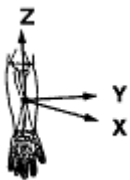
TABLE B3-6 - BODY-SEGMENT MOMENT OF INERTIA OF THE CREWMEMBER

Segment	Axis	Min (kg·m ² x10 ⁻³ [lb·ft ² x10 ⁻³])	Max (kg·m ² x10 ⁻³ [lb·ft ² x10 ⁻³])
Head 	Xp	15 (351)	22 (512)
	Yp	18 (424)	25 (587)
	Zp	14 (322)	16 (379)
Neck 	Xp	0.7 (17)	2.2 (53)
	Yp	1.0 (23)	2.7 (64)
	Zp	1.1 (25)	3.4 (81)
Thorax	Xp	183 (4,346)	680 (16,134)

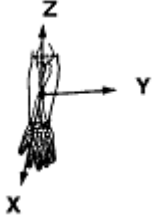
Segment	Axis	Min ($\text{kg}\cdot\text{m}^2\cdot\text{x}10^{-3}$ [$\text{lb}\cdot\text{ft}^2\cdot\text{x}10^{-3}$])	Max ($\text{kg}\cdot\text{m}^2\cdot\text{x}10^{-3}$ [$\text{lb}\cdot\text{ft}^2\cdot\text{x}10^{-3}$])
	Yp	135 (3,206)	505 (11,984)
	Zp	119 (2,833)	431 (10,236)
Abdomen 	Xp	15 (347)	23 (540)
	Yp	10 (241)	13 (309)
	Zp	21 (500)	35 (826)
Pelvis 	Xp	46 (1,092)	148 (3,514)
	Yp	34 (810)	137 (3,258)
	Zp	61 (1,440)	173 (4,104)
Torso 	Xp	638 (15,143)	2,030 (48,178)
	Yp	577 (13,702)	1840 (43,654)
	Zp	205 (4,865)	644 (15,273)
Right upper arm 	Xp	5.4 (129)	18 (430)
	Yp	5.6 (133)	19 (462)
	Zp	1.0 (24)	3.9 (92)

Segment	Axis	Min ($\text{kg}\cdot\text{m}^2 \times 10^{-3}$ [$\text{lb}\cdot\text{ft}^2 \times 10^{-3}$])	Max ($\text{kg}\cdot\text{m}^2 \times 10^{-3}$ [$\text{lb}\cdot\text{ft}^2 \times 10^{-3}$])
Left upper arm 	Xp	5.3 (126)	17.7 (420)
	Yp	5.5 (130)	19 (449)
	Zp	0.9 (22)	3.8 (89)
Right forearm 	Xp	2.8 (67)	12 (276)
	Yp	2.7 (65)	12 (282)
	Zp	0.5 (11)	1.8 (43)
Left forearm 	Xp	2.8 (66)	11 (257)
	Yp	2.7 (63)	11 (265)
	Zp	0.5 (11)	1.6 (39)
Right hand 	Xp	0.6 (14)	1.6 (38)
	Yp	0.5 (11)	1.3 (31)
	Zp	0.2 (4)	0.5 (13)
Left hand 	Xp	0.6 (15)	1.6 (37)
	Yp	0.5 (13)	1.3 (31)
	Zp	0.2 (4)	0.5 (12)

Segment	Axis	Min (kg·m ² ·x10 ⁻³ [lb·ft ² ·x10 ⁻³])	Max (kg·m ² ·x10 ⁻³ [lb·ft ² ·x10 ⁻³])
Right hip flap 	Xp	8.1 (191)	17 (412)
	Yp	10 (246)	22 (530)
	Zp	13 (318)	29 (696)
Left hip flap 	Xp	7.9 (188)	17 (398)
	Yp	11 (255)	22 (519)
	Zp	14 (324)	28 (671)
Right thigh minus flap 	Xp	34 (800)	79 (1,885)
	Yp	33 (785)	82 (1,941)
	Zp	14 (327)	32 (753)
Left thigh minus flap 	Xp	34 (798)	75 (1,784)
	Yp	33 (789)	79 (1,878)
	Zp	13 (317)	31 (729)
Right calf 	Xp	26 (615)	75 (1,790)
	Yp	26 (613)	76 (1,815)
	Zp	3.1 (73)	8.9 (210)

Segment	Axis	Min (kg·m ² ·x10 ⁻³ [lb·ft ² ·x10 ⁻³])	Max (kg·m ² ·x10 ⁻³ [lb·ft ² ·x10 ⁻³])
Left calf 	Xp	26 (614)	77 (1,826)
	Yp	26 (615)	78 (1,855)
	Zp	3.0 (70)	9.1 (215)
Right foot 	Xp	0.4 (9)	1.0 (24)
	Yp	1.6 (37)	5.5 (130)
	Zp	1.6 (39)	5.8 (138)
Left foot 	Xp	0.4 (9)	1.0 (24)
	Yp	1.6 (39)	5.4 (127)
	Zp	1.7 (41)	5.7 (134)
Right thigh 	Xp	85 (2,009)	208 (4,940)
	Yp	87 (2,063)	220 (5,215)
	Zp	27 (651)	59 (1,401)
	Xp	85 (2,022)	200 (4,757)
	Yp	88 (2,088)	212 (5,024)
	Zp	27 (649)	57 (1,350)
Right forearm plus hand 	Xp	11 (262)	40 (939)
	Yp	11 (257)	39 (935)
	Zp	0.7 (16)	2.4 (58)

BODY-SEGMENT MOMENT OF INERTIA OF THE CREWMEMBER (CONCLUDED)

Segment	Axis	Min (kg·m ² ·x10 ⁻³ ([lb·ft ² ·x10 ⁻³]))	Max (kg·m ² ·x10 ⁻³ ([lb·ft ² ·x10 ⁻³]))
	Xp	11 (260)	37 (887)
	Yp	11 (256)	37 (881)
	Zp	0.6 (15)	2.2 (53)
The axes in the figures above represent the principal axes.			





B4.0 STRENGTH





The information in the “other operations” and “Maximum Crew Operation Loads” columns were derived from a collection of journal articles associated with human strength data. In addition, other references were used, such as the MIL-STD-1472 and the Occupational and Biomechanics textbook (Chaffin, D. B., Occupation Biomechanics, Second Edition, John Wiley & Sons, Inc., 1991), to set a standard for very specific strength data such as lifting strength. Since there are so many variations in which strength data can be collected, the data in this table was consolidated in order to group similar motions and actions under the same category. The values in the criticality 1 and 2 columns were derived by applying a factor of safety of 2 and 1.5 respectively.





Criticality 1 and criticality 2 values were obtained by dividing the value in the other operations column by a factor of safety of 2 and 1.5 respectively. The values in the criticality 1 and 2 columns also include the decrement factor(s) to reflect the de-conditioning effects on crewmembers after an extended duration of mission. Criticality 1 load limits should be used for crew safety situations and the design of items where a single failure could result in loss of life or vehicle. Criticality 2 load limits should be used for the design of items where a single failure could result in a loss of mission.



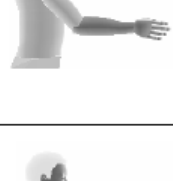


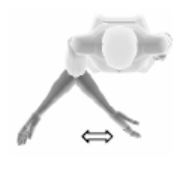

Criticality 1 is where a single failure could result in loss of life or vehicle. Criticality 2 is where a single failure could result in a loss of mission.




TABLE B4-1 - UNSUITED STRENGTH DATA




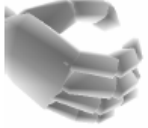
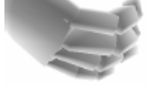


Type Of Strength		Minimum Crew Operation Loads (N(Lbf))			Maximum Crew Operational Loads (N(Lbf))
		Crit 1 Operations	Crit 2 Operations	Other Operations	
One Handed Pulls		One Handed Pulls			
Seated Horizontal Pull In ² [Subject in a seated position pulls towards his/her body. Unilateral/Isometric measurement]		111 (25)	147 (33)	276 (62)	449 (101)
Seated Vertical Pull Down ² [Subject in a seated position pulls downwards. Unilateral/Isometric measurement]		125 (28)	165 (37)	311 (70)	587 (132)
Seated Vertical Pull Up ² [Sitting erect with feet apart, dominant hand grasping D-ring located directly to the front above the floor, pulling upward while keeping shoulder squares & other arm in lap]		49 (11)	67 (15)	125 (28)	756 (170)
Standing Vertical Pull Up ² [Standing erect with feet apart, dominant hand grasping underside of D-ring located directly to the side above standing surface, pulling upward while keeping shoulders square and other arm relaxed at side]		53 (12)	71 (16)	133 (30)	725 (163)

Type Of Strength		Minimum Crew Operation Loads (N(Lbf))			Maximum Crew Operational Loads (N(Lbf))
		Crit 1 Operations	Crit 2 Operations	Other Operations	
Two Handed Pulls		Two Handed Pulls			
Standing Vertical Pull Down ² [Standing erect with feet apart, with both hands holding handle located above shoulders, pulling downward]		138 (31)	182 (41)	343 (77)	707 (159)
Standing Pull in ² [Standing erect with feet apart, with both hands holding handle located in front, pulling inward towards body]		58 (13)	80 (18)	147 (33)	391 (88)
Standing Vertical Pull Up ² [Standing with feet apart with a slight bend at the knees and waist, grasping a handle with both hands located directly in front and pulling upward]		89 (20)	116 (26)	218 (49)	1437 (323)
Seated Vertical Pull Up ² [Sitting erect with feet apart, grasping both sides of handle located directly to the front above the floor, pulling upward using arms and shoulders]		93 (21)	125 (28)	236 (53)	1188 (267)



Type Of Strength		Minimum Crew Operation Loads (N(Lbf))			Maximum Crew Operational Loads (N(Lbf))
		Crit 1 Operations	Crit 2 Operations	Other Operations	
One Handed Push		One Handed Push			
Seated Horizontal Push Out ² [Subject in a seated position pushing away from his/her body. Unilateral/Isometric measurement]		89 (20)	116 (26)	218 (49)	436 (98)
Seated Vertical Push Up ² [Subject in a seated position pushing upward in a vertical direction. Unilateral/Isometric measurement]		67 (15)	85 (19)	160 (36)	280 (63)
Two Handed Push		Two Handed Push			
Standing Vertical Push Down ² [Standing with feet apart with a slight bend at the knees and waist, grasping a handle with both hands located directly in front and pushing downwards]		102 (23)	133 (30)	254 (57)	525 (118)
Standing Horizontal Push Out ¹ [Standing erect with feet apart, with both hands holding handle located in front, pushing out away from body]		62 (14)	85 (19)	165 (37)	596 (134)

Type Of Strength		Minimum Crew Operation Loads (N(Lbf))			Maximum Crew Operational Loads (N(Lbf))
		Crit 1 Operations	Crit 2 Operations	Other Operations	
Two Handed Push		Two Handed Push			
Standing Vertical Push Up ² [Standing erect with feet apart, grasping from below, both sides of handle located directly in front above standing surface. Pushing upwards using arms and shoulders]		76 (17)	98 (22)	187 (42)	1094 (246)
Arm		Arm			
Arm Pull ² [Subject pulls handle forward and backward]		44 (10)	58 (13)	107 (24)	249 (56)
Arm Push ² [Subject pushes handle forward and backward]		40 (9)	53 (12)	98 (22)	222 (50)
Arm Up ² [Subject pushes and pulls handle in a various directions as shown by the figures]		18 (4)	22 (5)	40 (9)	107 (24)
Arm Down ² [Subject pushes and pulls handle in a various directions as shown by the figures]		22 (5)	31 (7)	58 (13)	116 (26)
Arm In ² [Subject moves handle medially]		22 (5)	31 (7)	58 (13)	98 (22)
Arm Out ² [Subject moves handle laterally]		13 (3)	18 (4)	36 (8)	76 (17)

Type Of Strength		Minimum Crew Operation Loads (N(Lbf))			Maximum Crew Operational Loads (N(Lbf))
		Crit 1 Operations	Crit 2 Operations	Other Operations	
Lifting		Lifting			
Lifting Strength ² [Standing with feet apart with a slight bend at the knees and waist, grasping a handle with both hands located directly in front and pulling upward using primarily arms and shoulders, and legs]		36 (8)	49 (11)	93 (21)	1228 (276)
Elbow		Elbow			
Flexion ² [Subject moves forearm in a sagittal plane around the elbow joint]		13 (3)	18 (4)	36 (8)	347 (78)
Extension ² [Subject moves forearm in a sagittal plane around the elbow joint]		27 (6)	36 (8)	67 (15)	249 (56)
Wrist & Hand		Wrist & Hand			
Pronation ² [Subject rotates hands and forearms medially]		165 (37)	222 (50)	414 (93)	876 (197)
Supination ² [Subject rotates hands and forearms laterally]		160 (36)	214 (48)	405 (91)	761 (171)

Type Of Strength		Minimum Crew Operation Loads (N(Lbf))			Maximum Crew Operational Loads (N(Lbf))
		Crit 1 Operations	Crit 2 Operations	Other Operations	
Wrist & Hand		Wrist & Hand			
Wrist Flexion ² [Subject bends wrist in a palmar direction]		31 (7)	40 (9)	76 (17)	209 (47)
Wrist Extension ² [Subject bends the wrist in a dorsal direction]		13 (3)	18 (4)	36 (8)	85 (19)
Pinch ¹ [Subject squeezes together the thumb and finger]		9 (2)	13 (3)	18 (4)	200 (45)
Grasp ¹ [Subject maintains an eccentric tight hold of an object]		347 (78)	463 (104)	694 (156)	1219 (274)
Grip ¹ [Subject maintains a concentric tight hold of an object]		49 (11)	67 (15)	102 (23)	783 (176)
Leg		Leg			
Hip Flexion ² [Subject moves leg in the sagittal plane around the hip joint toward the front of the body]		116 (26)	156 (35)	289 (65)	645 (145)
Hip Extension ² [Subject moves upper and lower leg in a sagittal plane around the hip joint]		191 (43)	254 (57)	476 (107)	658 (148)




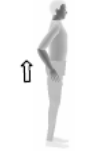
UNSUITED STRENGTH DATA (CONCLUDED)





Type Of Strength		Minimum Crew Operation Loads (N(Lbf))			Maximum Crew Operational Loads (N(Lbf))
		Crit 1 Operations	Crit 2 Operations	Other Operations	
Leg		Leg			
Leg Press ¹ [Subject moves leg in a sagittal plane around the hip joint toward the back of the body]		618 (139)	827 (186)	1552 (349)	2584 (581)
Knee Flexion ¹ [Subject moves lower leg in a sagittal plane around the knee joint]		53 (12)	71 (16)	138 (31)	325 (73)
Knee Extension ¹ [Subject moves lower leg in a sagittal plane around the knee joint]		142 (32)	191 (43)	383 (86)	783 (176)





¹ Post-space flight maximal measured strength decrement.




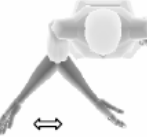
² Post-space flight estimated strength decrement. Range is 0%-26%. Average estimated is 20%. Based on max EDOMP Data. Not all motions were measured on EDOMP.






TABLE B4-2 - UNPRESSURIZED SUITED STRENGTH DATA

Type of Strength		Minimum Crew Operational Loads- N (lbf)			Maximum Crew Operational Loads- N (lbf)
		Crit 1 Operations	Crit 2 Operations	Other Operations	
One Handed Pulls		One Handed Pulls			
Seated Horizontal Pull In ² [Subject in a seated position pulls towards his/her body. Unilateral/Isometric measurement]		78(18)	103(23)	193(43)	314(71)
Seated Vertical Pull Down ² [Subject in a seated position pulls downwards. Unilateral/Isometric measurement]		88(20)	116(26)	218(49)	411(92)
Seated Vertical Pull Up ² [Sitting erect with feet apart, dominant hand grasping D-ring located directly to the front above the floor, pulling upward while keeping shoulder squares & other arm in lap]		34(8)	47(11)	88(20)	529(119)
Standing Vertical Pull Up ² [Standing erect with feet apart, dominant hand grasping underside of D-ring located directly to the side above standing surface, pulling upward while keeping shoulders square and other arm relaxed at side]		37(8)	50(11)	93(21)	508(114)




Type of Strength		Minimum Crew Operational Loads- N (lbf)			Maximum Crew Operational Loads- N (lbf)
		Crit 1 Operations	Crit 2 Operations	Other Operations	
Two Handed Pulls		Two Handed Pulls			
Standing Vertical Pull Down ²					
[Standing erect with feet apart, with both hands holding handle located above shoulders, pulling downward]		97(22)	127(29)	240(54)	495(111)
Standing Pull in ²					
[Standing erect with feet apart, with both hands holding handle located in front, pulling inward towards body]		41(9)	56(13)	103(23)	274(62)
Standing Vertical Pull Up ²					
[Standing with feet apart with a slight bend at the knees and waist, grasping a handle with both hands located directly in front and pulling upward]		62(14)	81(18)	153(34)	1006(226)
Seated Vertical Pull Up ²					
[Sitting erect with feet apart, grasping both sides of handle located directly to the front above the floor, pulling upward using arms and shoulders]		65(15)	88(20)	165(37)	832(187)

Type of Strength		Minimum Crew Operational Loads- N (lbf)			Maximum Crew Operational Loads- N (lbf)
		Crit 1 Operations	Crit 2 Operations	Other Operations	
One Handed Push		One Handed Push			
Seated Horizontal Push Out ² [Subject in a seated position pushing away from his/her body. Unilateral/Isometric measurement]		62(14)	81(18)	153(34)	305(69)
Seated Vertical Push Up ² [Subject in a seated position pushing upward in a vertical direction. Unilateral/Isometric measurement]		47(11)	60(13)	112(25)	196(44)
Two Handed Push		Two Handed Push			
Standing Vertical Push Down ² [Standing with feet apart with a slight bend at the knees and waist, grasping a handle with both hands located directly in front and pushing downwards]		71(16)	93(21)	178(40)	368(83)
Standing Horizontal Push Out ¹ [Standing erect with feet apart, with both hands holding handle located in front, pushing out away from body]		43(10)	60(13)	116(26)	417(94)

Type of Strength		Minimum Crew Operational Loads- N (lbf)			Maximum Crew Operational Loads- N (lbf)
		Crit 1 Operations	Crit 2 Operations	Other Operations	
Two Handed Push		Two Handed Push			
Standing Vertical Push Up ² [Standing erect with feet apart, grasping from below, both sides of handle located directly in front above standing surface. Pushing upwards using arms and shoulders]		53(12)	69(15)	131(29)	766(172)
Arm		Arm			
Arm Pull ² [Subject pulls handle forward and backward]		31(7)	41(9)	75(17)	174(39)
Arm Push ² [Subject pushes handle forward and backward]		28(6)	37(8)	69(15)	155(35)
Arm Up ² [Subject moves handle up]		13(3)	15(4)	28(6)	75(17)
Arm Down ² [Subject moves handle down]		15(4)	22(5)	41(9)	81(18)
Arm In ² [Subject moves handle medially]		15(4)	22(5)	41(9)	69(15)
Arm Out ² [Subject moves handle laterally]		9(2)	13(3)	25(6)	53(12)




Type of Strength		Minimum Crew Operational Loads- N (lbf)			Maximum Crew Operational Loads- N (lbf)
		Crit 1 Operations	Crit 2 Operations	Other Operations	
Lifting		Lifting			
Lifting Strength ² [Standing with feet apart with a slight bend at the knees and waist, grasping a handle with both hands located directly in front and pulling upward using primarily arms and shoulders, and legs]		25(6)	34(8)	65(15)	860(193)
Elbow		Elbow			
Flexion ^{2,3} [Subject moves forearm in a sagittal plane around the elbow joint]		9 (2)	13 (3)	25 (6)	243 (55)
Extension ^{2,3} [Subject moves forearm in a sagittal plane around the elbow joint]		19 (4)	25 (6)	47 (11)	174 (39)
Wrist & Hand		Wrist & Hand			
Pronation ^{2,3} [Subject rotates hands and forearms medially]		116 (26)	155 (35)	290 (65)	613 (138)
Wrist & Hand		Wrist & Hand			
Wrist Flexion ^{2,3} [Subject bends wrist in a palmar direction]		22 (5)	28 (6)	53 (12)	146 (33)
Wrist Extension ^{2,3} [Subject bends the wrist in a dorsal direction]		9 (2)	13 (3)	25 (6)	60 (13)
Pinch ¹ [Subject squeezes together the thumb and finger]		14 (3)	20 (5)	27 (6)	300(68)




UNPRESSURIZED SUITED STRENGTH DATA (Concluded)




Type of Strength		Minimum Crew Operational Loads- N (lbf)			Maximum Crew Operational Loads- N (lbf)
		Crit 1 Operations	Crit 2 Operations	Other Operations	
Grasp ^{1,3} [Subject maintains an eccentric tight hold of an object]		243 (55)	324 (73)	486 (109)	853 (192)
Grip ¹ [Subject maintains a concentric tight hold of an object]		25 (6)	34 (8)	51 (12)	392 (88)
Leg		Leg			
Hip Flexion ^{2,3} [Subject moves leg in the sagittal plane around the hip joint toward the front of the body]		81 (18)	109 (25)	202 (46)	452 (102)
Knee Flexion ^{1,5} [Subject moves lower leg in a sagittal plane around the knee joint, decreasing the angle between the upper and lower leg]		37 (8)	50 (11)	97 (22)	228 (51)
Knee Extension ^{1,3} [Subject moves lower leg in a sagittal plane around the knee joint, increasing the angle between the upper and lower leg]		99 (22)	134 (30)	268 (60)	548 (123)
<p>1. Post space flight maximal measured strength decrement.</p> <p>2. Post space flight estimated strength decrement. Range is 0%-47%. Average estimated is 33%. Based on CRV Requirements Document.</p> <p>3. Suit decrement not measured directly, but estimated based on functional strength testing of other movements</p>					




Revision: E	Document No: CxP 70024
Release Date: 11/19/10	Page: 375 of 503
Title: Constellation Program Human-Systems Integration Requirements	




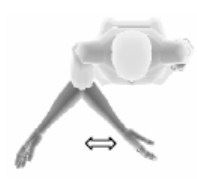
TABLE B4-3 - PRESSURIZED SUITED STRENGTH DATA



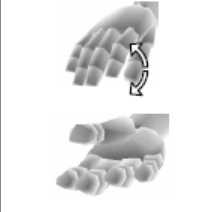
Type Of Strength		Minimum Crew Operation Loads (N(Lbf))			Maximum Crew Operational Loads (N(Lbf))
		Crit 1 Operations	Crit 2 Operations	Other Operations	
One Handed Pulls		One Handed Pulls			
Seated Horizontal Pull In ² [Subject in a seated position pulls towards his/her body. Unilateral/ Isometric measurement]		56(13)	74(17)	138(31)	225(51)
Seated Vertical Pull Down ² [Subject in a seated position pulls downwards. Unilateral/ Isometric measurement]		63(14)	83(19)	156(35)	294(66)
One Handed Pulls		One Handed Pulls			
Seated Vertical Pull Up ² [Sitting erect with feet apart, dominant hand grasping D-ring located directly to the front above the floor, pulling upward while keeping shoulder squares & other arm in lap]		25(6)	34(8)	63(14)	378(85)





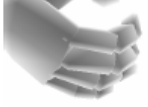
Type Of Strength	Minimum Crew Operation Loads (N(Lbf))			Maximum Crew Operational Loads (N(Lbf))	
	Crit 1 Operations	Crit 2 Operations	Other Operations		
One Handed Pulls		One Handed Pulls			
Standing Vertical Pull Up ² [Standing erect with feet apart, dominant hand grasping underside of D-ring located directly to the side above standing surface, pulling upward while keeping shoulders square and other arm relaxed at side]		27(6)	36(8)	67(15)	363(82)
Two Handed Pulls		Two Handed Pulls			
Standing Vertical Pull Down ² [Standing erect with feet apart, with both hands holding handle located above shoulders, pulling downward]		69(16)	91(21)	172(39)	354(80)
Standing Pull In ² [Standing erect with feet apart, with both hands holding handle located in front, pulling inward towards body]		29(7)	40(9)	74(17)	196(44)




Type Of Strength		Minimum Crew Operation Loads (N(Lbf))			Maximum Crew Operational Loads (N(Lbf))
		Crit 1 Operations	Crit 2 Operations	Other Operations	
Two Handed Pulls		Two Handed Pulls			
Standing Vertical Pull Up ² [Standing with feet apart with a slight bend at the knees and waist, grasping a handle with both hands located directly in front and pulling upward]		45(10)	58(13)	109(25)	719(162)
Seated Vertical Pull Up ² [Sitting erect with feet apart, grasping both sides of handle located directly to the front above the floor, pulling upward using arms and shoulders]		47(11)	63(14)	118(27)	594(134)
One Handed Push		One Handed Push			
Seated Horizontal Push Out ² [Subject in a seated position pushing away from his/her body. Unilateral/Isometric measurement]		45(10)	58(13)	109(25)	218(49)

Type Of Strength		Minimum Crew Operation Loads (N(Lbf))			Maximum Crew Operational Loads (N(Lbf))
		Crit 1 Operations	Crit 2 Operations	Other Operations	
One Handed Push		One Handed Push			
Seated Vertical Push Up ² [Subject in a seated position pushing upward in a vertical direction. Unilateral/Isometric measurement]		34(8)	43(10)	80(18)	140(32)
Two Handed Push		Two Handed Push			
Standing Vertical Push Down ² [Standing with feet apart with a slight bend at the knees and waist, grasping a handle with both hands located directly in front and pushing downwards]		51(12)	67(15)	127(29)	263(59)
Standing Horizontal Push Out ¹ [Standing erect with feet apart, with both hands holding handle located in front, pushing out away from body]		31(7)	43(10)	83(19)	298(67)

Type Of Strength		Minimum Crew Operation Loads (N(Lbf))			Maximum Crew Operational Loads (N(Lbf))
		Crit 1 Operations	Crit 2 Operations	Other Operations	
Two Handed Push		Two Handed Push			
Standing Vertical Push Up ² [Standing erect with feet apart, grasping from below, both sides of handle located directly in front above standing surface. Pushing upwards using arms and shoulders]		38(9)	49(11)	94(21)	547(123)
Arm		Arm			
Arm Pull ² [Subject pulls handle forward and backward]		22(5)	29(7)	54 (12)	125 (28)
Arm Push ² [Subject pushes handle forward and backward]		20(5)	27(6)	49 (11)	111 (25)
Arm Up ² [Subject moves handle up]		9(2)	11(3)	20 (5)	54(12)
Arm Down ² [Subject moves handle down]		11(3)	16(4)	29(7)	58(13)
Arm In ² [Subject moves handle medially]		11(3)	16(4)	29(7)	49 (11)
Arm Out ² [Subject moves handle laterally]		7(2)	9(2)	18 (4)	38 (9)

Type Of Strength		Minimum Crew Operation Loads (N(Lbf))			Maximum Crew Operational Loads (N(Lbf))
		Crit 1 Operations	Crit 2 Operations	Other Operations	
Lifting		Lifting			
Lifting Strength ² [Standing with feet apart with a slight bend at the knees and waist, grasping a handle with both hands located directly in front and pulling upward using primarily arms and shoulders, and legs]		18(4)	25(6)	47(11)	614(138)
Elbow		Elbow			
Flexion ^{2,3} [Subject moves forearm in a sagittal plane around the elbow joint]		7 (2)	9 (2)	18 (4)	174 (39)
Extension ^{2,3} [Subject moves forearm in a sagittal plane around the elbow joint]		14 (3)	18 (4)	34 (8)	125 (28)
Wrist & Hand		Wrist & Hand			
Pronation ^{2,3} [Subject rotates hands and forearms medially]		83 (19)	111 (25)	207 (47)	438 (99)
Supination ^{2,3} [Subject rotates hands and forearms laterally]		80 (18)	107 (24)	203 (46)	381 (86)

Type Of Strength		Minimum Crew Operation Loads (N(Lbf))			Maximum Crew Operational Loads (N(Lbf))
		Crit 1 Operations	Crit 2 Operations	Other Operations	
Wrist & Hand		Wrist & Hand			
Wrist Flexion ^{2,3} [Subject bends wrist in a palmar direction]		19 (4)	25 (6)	37 (8)	101 (23)
Wrist Extension ^{2,3} [Subject bends the wrist in a dorsal direction]		7 (2)	9 (2)	14 (3)	33 (7)
Pinch ¹ [Subject squeezes together the thumb and finger]		14 (3)	20 (5)	27 (6)	300(68)
Grasp ^{1,3} [Subject maintains an eccentric tight hold of an object]		174 (39)	232 (52)	347 (78)	610 (137)
Grip ¹ [Subject maintains a concentric tight hold of an object]		25 (6)	34 (8)	51 (12)	392 (88)

Type Of Strength		Minimum Crew Operation Loads (N(Lbf))			Maximum Crew Operational Loads (N(Lbf))
		Crit 1 Operations	Crit 2 Operations	Other Operations	
Leg		Leg			
Hip Flexion ^{2,3} [Subject moves leg in the sagittal plane around the hip joint toward the front of the body]		58 (13)	78 (18)	145 (33)	323 (73)
Hip Extension ^{2,3} [Subject moves leg in a sagittal plane around the hip joint toward the back of the body]		96 (22)	127 (29)	238 (54)	329 (74)
Leg Press ^{1,3} [Subject pushes a weight away from them using their legs]		309 (70)	414 (93)	776 (175)	1292 (291)
Knee Flexion ^{1,3} [Subject moves lower leg in a sagittal plane around the knee joint]		27 (6)	36 (8)	69 (16)	163 (37)
Knee Extension ¹ [Subject moves lower leg in a sagittal plane around the knee joint]		71 (16)	96 (22)	192 (43)	392 (88)

- . 1. Post space flight maximal measured strength decrement.
- . 2. Post space flight estimated strength decrement. Range is 0%-47%. Average estimated is 33%. Based on CRV Requirements Document.
- . 3. Suit decrement not measured directly, but estimated based on functional strength testing of other movements

Revision: E	Document No: CxP 70024
Release Date: 11/19/10	Page: 383 of 503
Title: Constellation Program Human-Systems Integration Requirements	

**APPENDIX C
NATURAL AND INDUCED ENVIRONMENTS**

C1.0 ATMOSPHERE

TABLE C1-1 - CRITERIA FOR ASSIGNMENT OF TOXICOLOGICAL HAZARD LEVELS

Hazard level	Irritancy	Systemic Effects	Containability and Decontamination
0 (Non hazard)	Slight irritation that lasts <30 minutes and will not require therapy.	None	Gas, solid, or liquid may or may not be containable.
1 (Critical)	Slight to moderate irritation that lasts >30 min and will require therapy.	Minimal effects, no potential for lasting internal tissue damage.	Gas, solid, or liquid may or may not be containable. However, the crew will be protected from liquids and solids by surgical masks, gloves, and goggles.
2 (Catastrophic)	Moderate to severe irritation that has the potential for long-term performance decrement and will require therapy. Eye Hazards: May cause permanent damage.	None	Either a solid or nonvolatile liquid. Can be contained by a cleanup procedure and disposed of. The crew will be protected by 5-micron surgical masks, gloves, and goggles.

Revision: E	Document No: CxP 70024
Release Date: 11/19/10	Page: 384 of 503
Title: Constellation Program Human-Systems Integration Requirements	

**CRITERIA FOR ASSIGNMENT OF TOXICOLOGICAL HAZARD LEVELS
(CONCLUDED)**

Hazard level	Irritancy	Systemic Effects	Containability and Decontamination
3 (Catastrophic)	Irritancy alone does not constitute a level 3 hazard.	Appreciable effects on coordination, perception, memory, etc., or has the potential for long-term (delayed) serious injury (e.g., cancer), or may result in internal tissue damage.	Either a solid or nonvolatile liquid that can be contained by a cleanup crew and disposed of. Surgical masks and gloves will not protect the crew. Either quick-don masks or Spacehab Emergency Breathing System (SEBS) and gloves are required.
4 (Catastrophic)	Moderate to severe irritancy that has the potential for long-term crew performance decrement (for eye-only hazards, there may be a risk of permanent eye damage.) Note: Will require therapy if crew is exposed.	Appreciable effects on coordination, perception, memory, etc., or the potential for long-term (delayed) serious injury (e.g., cancer) or may result in internal tissue damage.	Gas, volatile liquid, or fumes that are not containable. The ARS will be used to decontaminate. Either the quick-don masks or the SEBS are required or the contaminated module will be evacuated.

NOTE: This table was extracted from JSC-26895, Guidelines for Assessing the Toxic Hazard of Spacecraft Chemicals and Test Materials.

C2.0 ACCELERATION AND VIBRATION

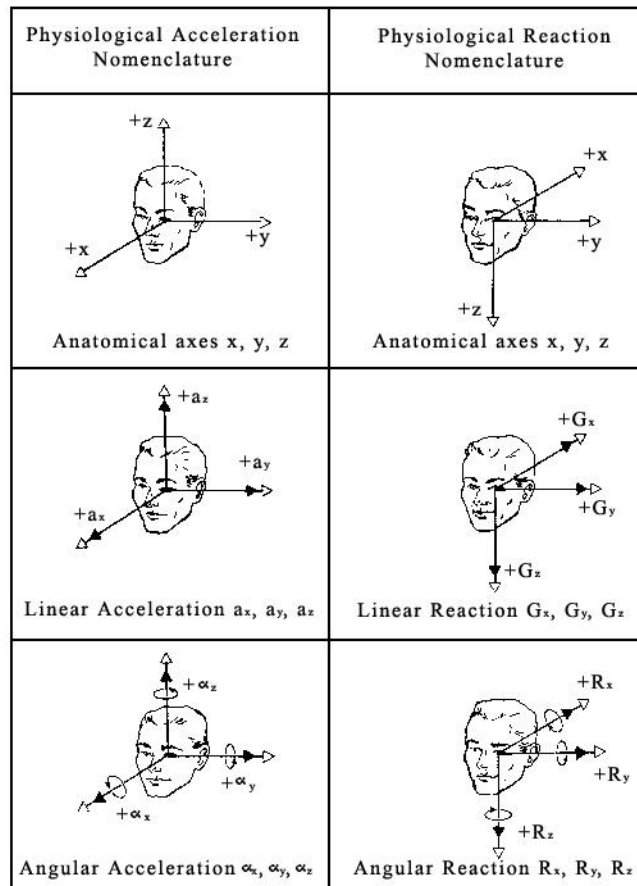


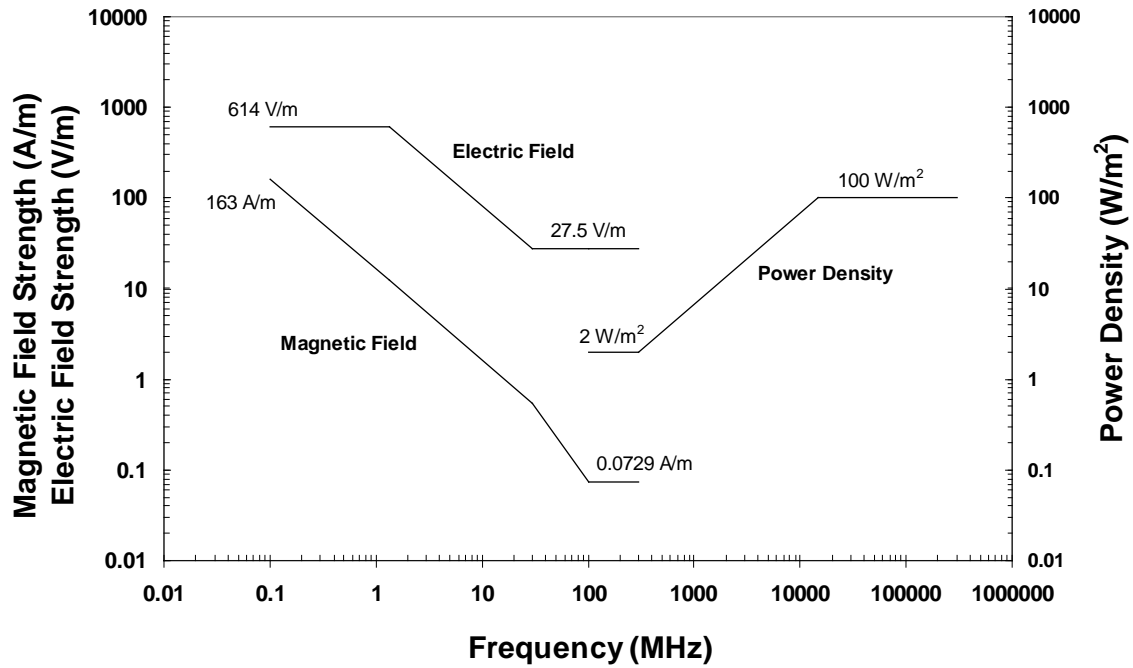
FIGURE C2-1 - ACCELERATION ENVIRONMENT COORDINATE SYSTEM

Revision: E	Document No: CxP 70024
Release Date: 11/19/10	Page: 386 of 503
Title: Constellation Program Human-Systems Integration Requirements	

TABLE C2-1 - DIRECTION AND INTERTIAL RESULTANT OF BODY ACCELERATION

a. Direction of Acceleration			
Linear Motion	Aircraft Standard	Acceleration Description	
Forward	+a _x	Forward acceleration	
Backward	-a _x	Backward acceleration	
Upward	+a _z	Headward acceleration	
Downward	-a _z	Footward acceleration	
To the Right	-a _y	Rightward acceleration	
To the Left	+a _y	Leftward acceleration	
b. Inertial Resultant of Body Acceleration			
Linear Motion	Physiologic Descriptive	Physiologic Standard	Vernacular Descriptive
Forward	Transverse anterior-posterior G, prone G, chest to back G	+G _x	Eyeballs-in
Backward	Transverse posterior-anterior G, supine G, back to chest G	-G _x	Eyeballs-out
Upward	Positive G	+G _z	Eyeballs-down
Downward	Negative G	-G _z	Eyeballs-up
To the right	Lateral G	+G _y	Eyeballs-left
To the left	Lateral G	-G _y	Eyeballs-right
Note: G expresses inertial resultant to whole-body acceleration in multiples of the magnitude of the acceleration of gravity. Acceleration of gravity, g=9.80665 m/s ²			

C3.0 NON-IONIZING RADIATION



**FIGURE C3-1 - RADIO FREQUENCY ELECTROMAGNETIC FIELD EXPOSURE LIMITS
(ILLUSTRATED TO SHOW WHOLE BODY RESONANCE EFFECTS AROUND 100 MHZ)
(MODIFIED FROM IEEE C95.1-2005)**

TABLE C3-1 - MAXIMUM PERMISSIBLE EXPOSURE (MPE) TO RADIO FREQUENCY ELECTROMAGNETIC FIELDS (MODIFIED FROM IEEE C95.1-2005, LOWER TIER)

Frequency Range (MHz)	RMS Electric Field Strength (E) ^a (V/m)	RMS Magnetic Field Strength (H) ^a (A/m)	RMS Power Density (S) E-Field, H-Field (W/m ²)	Averaging Time ^b E ² , H ² , or S (minutes)	
0.1 – 1.34	614	16.3/f _M	(1,000, 100,000/f _M ²) ^c	6	6
1.34 - 3	823.8/f _M	16.3/f _M	(1,800/f _M ² , 100,000/f _M ²)	f _M ² /0.3	6
3 - 30	823.8/f _M	16.3/f _M	(1,800/f _M ² , 100,000/f _M ²)	30	6
30 - 100	27.5	158.3/f _M ^{1.668}	(2, 9,400,000/f _M ^{3.336})	30	0.0636f _M ^{1.337}
100–300	27.5	0.0729	2	30	30
300–5,000	–	–	f /150	30	
5,000–15,000	–	–	f /150	150/f _G	
15,000–30,000	–	–	100	150/f _G	
30,000–100,000	–	–	100	25.24/f _G ^{0.476}	
100,000–300,000	–	–	100	5048/[(9f _G -700)f _G ^{0.476}	

f_M is the frequency in MHz, f_G is the frequency in GHz.

For exposures that are uniform over the dimensions of the body, such as certain far-field plane-wave exposures, the exposure field strengths and power densities are compared with the MPEs in the Table. For non-uniform exposures, the mean values of the exposure fields, as obtained by spatially averaging the squares of the field strengths or averaging the power densities over an area equivalent to the vertical cross section of the human body (projected area), or a smaller area depending on the frequency (for further details please see IEEE C95.1-2005, notes to Table 8 and Table 9), are compared with the MPEs in the Table.

The left column is the averaging time for |E|², the right column is the averaging time for |H|². For frequencies greater than 400 MHz, the averaging time is for power density S.

These plane-wave equivalent power density values are commonly used as a convenient comparison with MPEs at higher frequencies and are displayed on some instruments in use.

TABLE C3-2 - BLUE-LIGHT AND RETINAL THERMAL HAZARD FUNCTIONS

Wavelength (nm)	Blue-Light Hazard Function, B(λ)	Retinal Thermal Hazard Function, R(λ)
305-335	0.01	-
340	0.01	-
345	0.01	-
350	0.01	-
355	0.01	-
360	0.01	-
365	0.01	-
370	0.01	-
375	0.01	-
380	0.01	0.01
385	0.0125	0.0125
390	0.025	0.025
395	0.050	0.050
400	0.100	0.100
405	0.200	0.200
410	0.400	0.400
415	0.800	0.800
420	0.900	0.900
425	0.950	0.950
430	0.980	0.980
435	1.00	1.00
440	1.00	1.00
445	0.970	1.00
450	0.940	1.00
455	0.900	1.00
460	0.800	1.00
465	0.700	1.00
470	0.620	1.00
475	0.550	1.00

BLUE-LIGHT AND RETINAL THERMAL HAZARD FUNCTIONS (CONCLUDED)

Wavelength (nm)	Blue-Light Hazard Function, $B(\lambda)$	Retinal Thermal Hazard Function, $R(\lambda)$
480	0.450	1.00
485	0.400	1.00
490	0.220	1.00
495	0.160	1.00
500	0.100	1.00
505	0.079	1.00
510	0.063	1.00
515	0.050	1.00
520	0.040	1.00
525	0.032	1.00
530	0.025	1.00
535	0.020	1.00
540	0.016	1.00
545	0.013	1.00
550	0.010	1.00
555	0.008	1.00
560	0.006	1.00
565	0.005	1.00
570	0.004	1.00
575	0.003	1.0
580	0.002	1.0
585	0.002	1.0
590	0.001	1.0
595	0.001	1.0
600-700	0.001	1.0
700-1050	-	$10^{[(700-\lambda)/500]}$
1050-1400	-	0.2

Revision: E	Document No: CxP 70024
Release Date: 11/19/10	Page: 391 of 503
Title: Constellation Program Human-Systems Integration Requirements	

TABLE C3-3 - UV RADIATION EXPOSURE TLV AND SPECTRAL WEIGHTING FUNCTION

Wavelength (nm)	TLV (J/m ²)	TLV (mJ/cm ²)	Relative Spectral Effectiveness, S _λ
180	2500	250	0.012
190	1600	160	0.019
200	1000	100	0.030
205	590	59	0.051
210	400	40	0.075
215	320	32	0.095
220	250	25	0.120
225	200	20	0.150
230	160	16	0.190
235	130	13	0.240
240	100	10	0.300
245	83	8.3	0.360
250	70	7.0	0.430
255	58	5.8	0.520
260	46	4.6	0.650
265	37	3.7	0.810
270	30	3.0	1.000
275	31	3.1	0.960
280	34	3.4	0.880
285	39	3.9	0.770
290	47	4.7	0.640
295	56	5.6	0.540
300	100	10	0.300
305	500	50	0.06
310	2000	200	0.015
315	1.0*10 ⁴	1000	0.003
320	2.9*10 ⁴	2900	0.0024
325	6.0*10 ⁴	6000	0.00050
330	7.3*10 ⁴	7300	0.00041
335	8.8*10 ⁴	8800	0.00034

**UV RADIATION EXPOSURE TLV AND SPECTRAL WEIGHTING FUNCTION
(CONCLUDED)**

Wavelength (nm)	TLV (J/m ²)	TLV (mJ/cm ²)	Relative Spectral Effectiveness, S _λ
340	1.1*10 ⁵	1.1*10 ⁴	0.00028
345	1.3*10 ⁵	1.3*10 ⁴	0.00024
350	1.5*10 ⁵	1.5*10 ⁴	0.00020
355	1.9*10 ⁵	1.9*10 ⁴	0.00016
360	2.3*10 ⁵	2.3*10 ⁴	0.00013
365	2.7*10 ⁵	2.7*10 ⁴	0.00011
370	3.2*10 ⁵	3.2*10 ⁴	0.000093
375	3.9*10 ⁵	3.9*10 ⁴	0.000077
380	4.7*10 ⁵	4.7*10 ⁴	0.000064
385	5.7*10 ⁵	5.7*10 ⁴	0.000053
390	6.8*10 ⁵	6.8*10 ⁴	0.000044
395	8.3*10 ⁵	8.3*10 ⁴	0.000036
400	1.0*10 ⁶	1.0*10 ⁵	0.000030

TABLE C3-4 - PERMISSIBLE ULTRAVIOLET EXPOSURES (200 - 400 NM)

Duration of Exposure per Day	Effective Irradiance, μW/cm ²
8 hrs.	0.1
4 hrs.	0.2
2 hrs.	0.4
1 hr.	0.8
30 min.	1.7
15 min.	3.3
10 min.	5
5 min.	10
1 min.	50
30 sec.	100
10 sec.	300
1 sec.	3000
0.5 sec.	6000
0.1 sec.	30000

APPENDIX D SAFETY

TABLE D-1 - CORNER AND EDGE ROUNDING REQUIREMENTS

Material Thickness, t	Minimum Corner Radius	Minimum Edge Radius	Figure
t > 25 mm (t > 1 in)	13 mm (0.5 in (spherical))	3.0 mm (0.120 in)	
6.5 mm < t < 25 mm (0.25 in < t < 1 in)	13 mm (0.5 in)	3.0 mm (0.125 in)	
3.0 mm < t < 6.5 mm (0.125 in < t < 0.25 in)	6.5 mm (0.26 in)	1.5 mm (0.06 in)	
0.5 mm < t < 3.0 mm (0.02 in < t < 0.125 in)	6.5 mm (0.26 in)	Full radius	
t < 0.5 mm (t < 0.02 in)	6.5 mm (0.26 in)	Rolled, curled, or covered to 3.0 mm (0.120 in)	

Revision: E	Document No: CxP 70024
Release Date: 11/19/10	Page: 394 of 503
Title: Constellation Program Human-Systems Integration Requirements	

APPENDIX E THERMAL COMFORT AND METABOLIC LOADS

E1.0 THERMAL COMFORT AND METABOLIC LOADS

Thermal Comfort: Human comfort without use of thermal protective garments requires a fairly narrow temperature range. The comfort zone is defined as the range of environmental conditions in which humans can achieve thermal comfort and can perform routine activities without the negative effects of thermal stress. Thermal comfort is affected by work rate, clothing, and state of acclimatization. Appendix E, figure Environmental Comfort Zone is a graphical representation of the comfort zone. The comfort zone does not include the entire range of conditions in which humans can survive indefinitely. The indefinite survival zone is larger and might require active perspiration or shivering, responses that are initiated by elevated or lowered core temperatures. Operation outside the comfort zone may be associated with performance decrements. The graph implies minimal air movement and assumes that the radiant temperature of the surrounding environment is at the dry bulb temperature. The effects of acclimatization, work, and heavier clothing are shown as data trends by the arrows on the graph. This temperature range has been used successfully for STS and ISS vehicular operations.

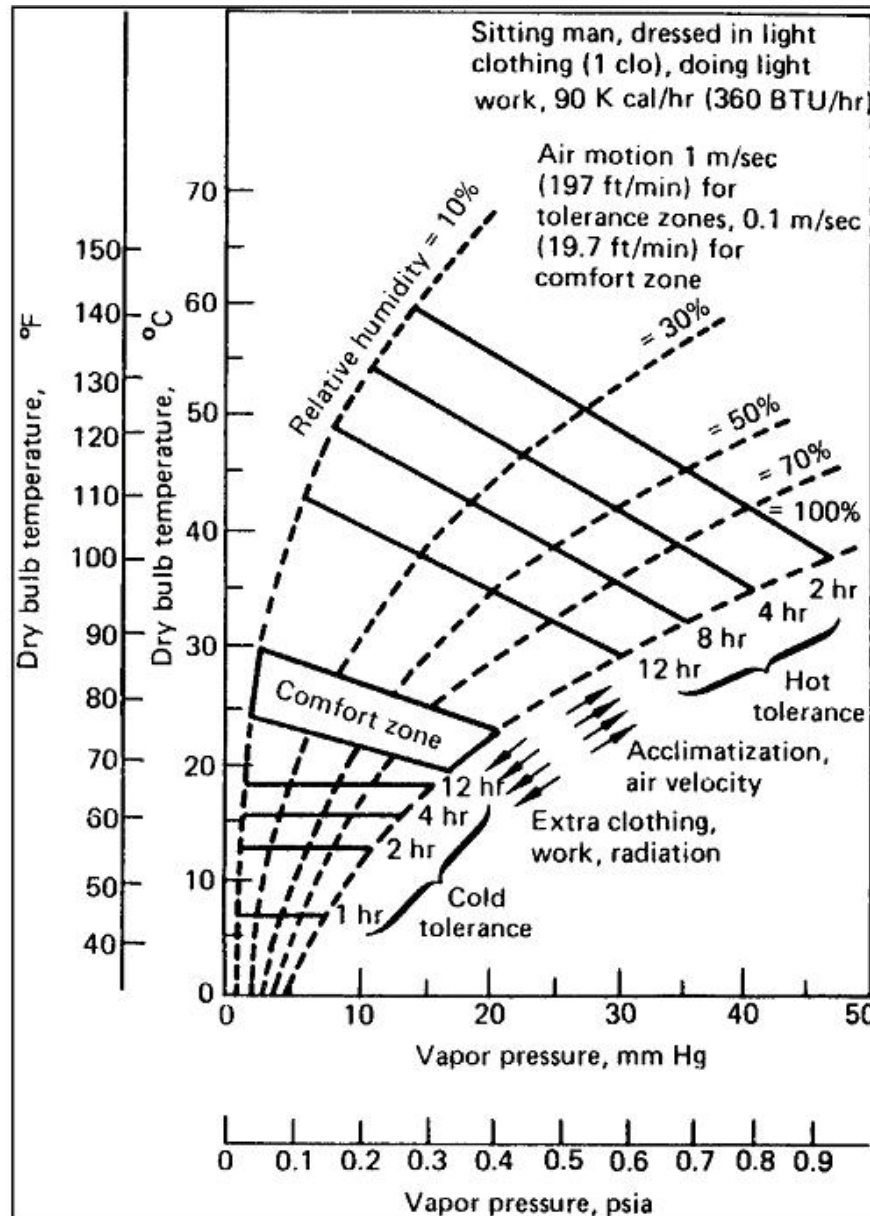


FIGURE E1-1 - ENVIRONMENTAL COMFORT ZONE

Heat Storage and Rejection: The thermal comfort objective is to maintain body thermal storage within the comfort zone defined by the equation:

$$\Delta Q_{\text{stored}} = \frac{MR - 278}{13.2} \pm 65 \text{ BTU}$$

where MR = Metabolic Rate in BTU/hr, and ΔQ_{stored} is the change in heat stored from nominal quantity of heat stored in the human body at normal body temperature at rest (For correlation with Appendix E, figure Heat Storage, this calculation can be converted to BTU/lb by dividing the ΔQ_{stored} [BTU] by 154 lb [the legacy standard man weight]. This number can be further converted to kJ/kg using the conversion factors of 1 BTU = 1055.056 J and 1 lb = 0.4535924 kg).

Accepted means of heat storage or rejection (ΔQ_{stored}) calculation is per 41-node man or Wissler model. The ΔQ stored equation is plotted in Appendix E, figure Heat Storage to graphically show the human comfort boundaries. For example, a crewmember with a metabolic rate of 1,705 BTU/hr will be in the middle of the comfort zone at approximately 1.6 kJ/kg (0.7 BTU/lb) of stored body heat above normal resting storage. Heat storage and rejection tolerance limits are also shown in Appendix E, figure Heat Storage. During those portions of a mission when cabin conditions cannot be maintained within nominal limits, short periods of departure from the comfort zone can be accommodated by crewmembers through heat storage or loss, not to exceed:

$$4.7 \text{ kJ/kg (2.0 BTU/lb)} > \Delta Q_{\text{stored}} > -4.1 \text{ kJ/kg (-1.8 BTU/lb)}$$

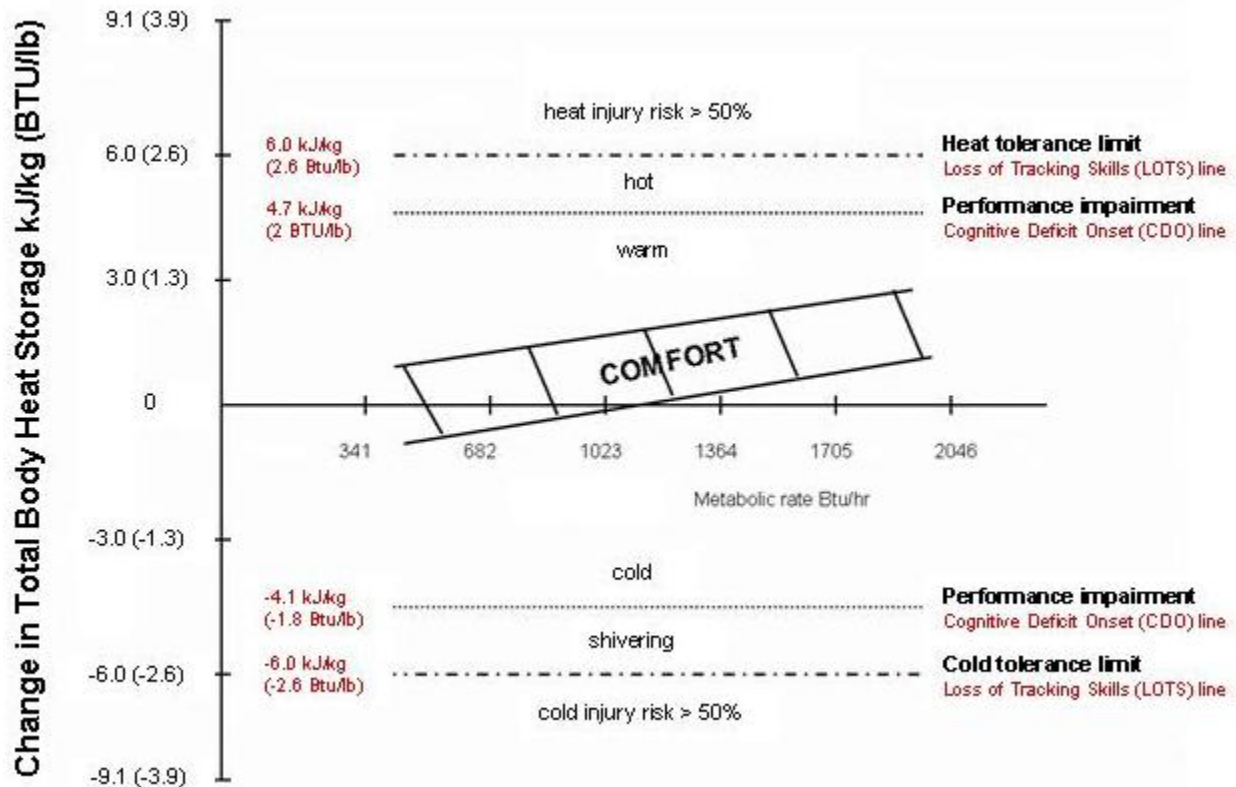


FIGURE E1-2 - HEAT STORAGE

Heat storage: A vehicular cabin with excess heat load may quickly reach crew tolerance limits and impair crew performance and health. Crew impairment begins when pulse is greater than 140 bpm or when skin temperature increases more than 1.4 °C (2.5 °F) (0.6 °C [1 °F] core), which correlates with heat storage of approximately 4.7 kJ/kg (2.0 BTU/lb). Appendix E, table Core Temperature Range Limits and Associated Performance Decrements identifies core temperature range limits and associated performance decrements. Maintaining crewmember heat storage below the performance impairment level (also known as the Cognitive Deficit Onset [CDO] line, Appendix E, figure Heat Storage) allows the crew the ability to conduct complex tasks without heat-induced performance degradation. Precise prediction of crew tolerances

Revision: E	Document No: CxP 70024
Release Date: 11/19/10	Page: 397 of 503
Title: Constellation Program Human-Systems Integration Requirements	

and time constraints for entry are not possible: therefore, environmental temperature must be controlled.

In a non-acclimatized individual, water loss is approximately 0.95 L (32 oz) per hour and salt loss is approximately 2 to 3 grams (0.0044 to 0.0066 lb) per hour. In microgravity and elevated humidity, sweat forms an insulating layer over the body, further adding to the heat stress instead of relieving it. Losses may be less in a thermally acclimatized individual.

Heat rejection: If heat is removed from the body to the point of thermogenic shivering, crew task performance will be impaired in a similar fashion to excess heat storage. Like the condition of excess heat storage, which can be mitigated by specialized cooling garments, excess heat rejection can be mitigated to some degree by the use of insulating garments. Appendix E, figure Environmental Comfort Zone shows the effect of tolerance to cold temperature and wind by the addition of varying degrees of thermal protecting clothing. Keeping crewmember heat rejection above the performance impairment level (Appendix E, figure Heat Storage) allows the crew to conduct tasks without cold-induced performance degradation, which occurs at approximately - 4.1 kJ/kg (-1.8 BTU/lb).

TABLE E1-1 - CORE TEMPERATURE RANGE LIMITS AND ASSOCIATED PERFORMANCE DECREMENTS

Core Temperature °C (°F)	Approximate Heat Storage kJ/kg (BTU/lb)	Medical Condition
37.7-38.2 (99.9-100.8)	4.7-6.0 (2.0-2.6)	Heat-associated discomfort Hyperthermia/heat stress manifestations Mild performance impairment Decreasing manual dexterity Cognitive Deficit Onset (CDO)
38.2-39.2 (100.8-102.6)	6.0-9.1 (2.6-3.9)	Increased errors in judgment Moderate performance decrement Loss of Tracking Skills (LOTS) 25% risk of heat casualties Possible heat exhaustion
39.2-40 (102.6-104)	9.1-12.1 (3.9-5.2)	Functional limit of physical tasks Severe performance decrement 50% risk of heat casualties Probable heat exhaustion Possible heat stroke Possible permanent disability
>40 (>104)	>12.1 (>5.2)	Unable to perform tasks 100% risk of heat casualties Probable heat stroke Probable permanent disability

Revision: E	Document No: CxP 70024
Release Date: 11/19/10	Page: 398 of 503
Title: Constellation Program Human-Systems Integration Requirements	

In summary, the thermal comfort objectives are that: 1) body thermal storage be within the comfort zone, 2) evaporative heat losses be limited to insensible evaporation of moisture produced only by respiration and diffusion through the skin without active sweating, 3) there is no thermogenic shivering, and 4) body core temperatures are maintained near the normal resting values of approximately 37 °C (99 °F), and 5) skin temperatures are maintained near normal resting values of approximately 32.8 °C to 34.4 °C (91 °F to 94 °F) when no Liquid Cooling Garments (LCGs) are used. During LCG use, skin temperatures will be significantly lower.

Expected Metabolic Loads: In order to allow calculation of vehicle environmental control system capacity, it is necessary to know expected crewmember metabolic loads, which will be affected by the magnitude of work being performed. Appendix E, table Crew Induced Metabolic Loads For A Standard Mission Day With Exercise provides estimates of metabolically generated heat (column 5), water (column 6), and CO₂ (column 9). This table was populated with physiologically measured parameters as well as 41-Node man simulations. These are expected crew induced loads based on the assumptions and conditions stated in the legend, and therefore will be altered if any of these variables change.

Crew Induced Metabolic Loads for a Standard Mission Day: The data represent crew induced loads from a single crewmember. In addition to any vehicle and equipment induced loads, the vehicle must accommodate crew induced loads for the entire crew, assuming that only one crewmember can exercise at a time and assuming that other crewmembers will be at nominal activity level during that time. Each crewmember must be able to exercise at this level once per day. Total heat output from a single crewmember is the sum of sensible (dry) heat and wet heat outputs. The sensible (dry) heat component includes only direct radiation and convection of heat from a crewmember. Total wet heat includes two components: 1) latent heat, including heat in water vapor, which is exhaled, and that of which evaporates directly from the skin, and 2) sweat run-off, which includes heat in sweat which leaves the body in the form of liquid. For purposes of vehicle design modeling, O₂ consumption and CO₂ output are considered to be at 75% VO₂ max level during exercise, and return to nominal values when exercise has stopped. Water, O₂, and CO₂ are reported as kilograms and pounds mass, with O₂ and CO₂ converted from STPD data. The table data assume an 82-kg (181-lb) crewmember, a 30-minute exercise period, VO₂max = 45 mL/kg/min (1.25 in³/lb/min) at STPD, 5% work efficiency of the exercise device, air and wall temperature = 21 °C (70 °F), air flow = 9.1 m/min (30 ft/min), dew point = 10 °C (50 °F), vehicle pressure = 70.3 kPa (10.2 psia), 0g loading, respiratory quotient = 0.92 (must be applied volumetrically), crewmember wearing shorts and t-shirt, sleeping metabolic rate of 300 BTU/hr, nominal metabolic rate of 474 BTU/hr. and a metabolic rate of 500 BTU/hr for the hour immediately after exercise completion. The variability of this analysis is 5%. If any of the above conditions or assumptions changes, the described loads will be altered.

TABLE E1-2 - CREW INDUCED METABOLIC LOADS FOR A STANDARD MISSION DAY WITH EXERCISE

1	2	3	4	5	6	7	8	9
Crew Member Activity Description	Duration of Activity (hr)	Sensible (dry) Heat Output kJ/hr (btu/hr)	Wet Heat Output (includes latent and sweat run-off) kJ/hr (btu/hr)	Total Heat Output Rate kJ/hr (btu/hr) ⁽²⁾	Water Vapor Output kg/min* 10 ⁻⁴ (lbm/min* 10 ⁻⁴)	Sweat Runoff Rate kg/min* 10 ⁻⁴ (lbm/min* 10 ⁻⁴)	O ₂ Consumption ⁽⁴⁾ kg/min* 10 ⁻⁴ (lbm/min* 10 ⁻⁴)	CO ₂ Output ⁽⁴⁾ kg/min* 10 ⁻⁴ (lbm/min* 10 ⁻⁴)
Sleep	8	224 (213)	92 (87)	317 (300)	6.30 (13.90)	0.00 (0.00) ⁽¹⁾	3.60 (7.94)	4.55 (10.03)
Nominal	14.5	329 (312)	171 (162)	500 (474)	11.77 (25.95)	0.00 (0.00) ⁽¹⁾	5.68 (12.55)	7.20 (15.87)
Exercise 0 - 15 min at 75% VO ₂ max	0.25	514 (487)	692 (656)	1206 (1143)	46.16 (101.76)	1.56 (3.43)	39.40 (86.86)	49.85 (109.90)
Exercise 15 - 30 min at 75% VO ₂ max	0.25	624 (591)	2351 (2228)	2974 (2819)	128.42 (283.13)	33.52 (73.90)	39.40 (86.86)	49.85 (109.90)
Recovery 0 - 15 min post 75% VO ₂ max	0.25	568 (538)	1437 (1362)	2005 (1900)	83.83 (184.82)	15.16 (33.43)	5.68 (12.55)	7.2 (15.86)
Recovery 15 - 30 min post 75% VO ₂ max	0.25	488 (463)	589 (559)	1078 (1022)	40.29 (88.82)	0.36 (0.79)	5.68 (12.55)	7.2 (15.86)
Recovery 30 - 45 min post 75% VO ₂ max	0.25	466 (442)	399 (378)	865 (820)	27.44 (60.50)	0.00 (0.00) ⁽¹⁾	5.68 (12.55)	7.2 (15.86)
Recovery 45 - 60 min post 75% VO ₂ max	0.25	455 (431)	296 (281)	751 (712)	20.40 (44.98)	0.00 (0.00) ⁽¹⁾	5.68 (12.55)	7.2 (15.86)
Total Per Day ⁽³⁾	24	7351 (6967)	4649 (4410)	12000 (11377)	1.85 (4.07)	0.08 (0.17)	0.82 (1.80)	1.04 (2.29)

TABLE E1-3 - CREW INDUCED METABOLIC LOADS FOR A STANDARD MISSION DAY, NO EXERCISE

1	2	3	4	5	6	7	8	9
Crew Member Activity Description	Duration of Activity (hr)	Sensible (dry) Heat Output kJ/hr (btu/hr)	Wet Heat Output (includes latent and sweat run-off) kJ/hr (btu/hr)	Total Heat Output Rate kJ/hr (btu/hr) ⁽²⁾	Water Vapor Output kg/min* 10 ⁻⁴ (lbm/min* 10 ⁻⁴)	Sweat Runoff Rate kg/min* 10 ⁻⁴ (lbm/min* 10 ⁻⁴)	O ₂ Consumption ⁽⁴⁾ kg/min* 10 ⁻⁴ (lbm/min* 10 ⁻⁴)	CO ₂ Output ⁽⁴⁾ kg/min* 10 ⁻⁴ (lbm/min* 10 ⁻⁴)
Sleep	8	224 (213)	92 (87) ⁽¹⁾	317 (300)	6.30 (13.90)	0.00 (0.00) ⁽¹⁾	3.60 (7.94)	4.55 (10.03)
Nominal	16	329 (312)	171 (162) ⁽¹⁾	500 (474)	11.77 (25.95)	0.00 (0.00) ⁽¹⁾	5.68 (12.55)	7.20 (15.87)
Total Per Day ⁽³⁾	24	7056 (6696)	3472 (3288)	10536 (9984)	1.43 (3.16)	0.00 (0.00) ⁽¹⁾	0.72 (1.59)	0.91 (2.00)

- 1) These values do not include a sweat run-off component, as none is expected.
- 2) This column will reflect a lag between metabolic rate and heat output.
- 3) There are no multipliers applied to the Totals Row.
- 4) A respiratory quotient of 0.92 was assumed for the oxygen consumption and carbon dioxide output determinations.

Rationale and input assumptions for metabolic Appendix E, table Crew Induced Metabolic Loads For A Standard Mission Day With Exercise and table Crew Induced Metabolic Loads For A Standard Mission Day, No Exercise:

- 1) Male - Male because more astronauts are male than female, and with a crew of males, metabolic rates will encompass the loads generated by that of a mixed crew or a crew of all females.
- 2) 82 kg Weight - Current astronaut corps average weight for males is 78 kg and projected male astronaut corps average weight for 2015 is 82 kg. Additional calculations of metabolic expenditure were also made assuming different masses of crewmembers, and the

Revision: E	Document No: CxP 70024
Release Date: 11/19/10	Page: 400 of 503
Title: Constellation Program Human-Systems Integration Requirements	

- output/loads change in a corresponding linear fashion; however the 82 kg assumed mass is felt to be most representative for sizing ECLSS systems.
- 3) Thermo-Neutral Environment - Constant Temp = 70 °F and Constant Dew Point = 50 °F, a team of Physiologist, Engineers and Scientist agreed on environmental conditions for the model input.
 - 4) Astronaut Corps Fitness Level - max VO_2 = 48 mL/kg/min +/- 6 mL/kg/min, this value was quantified from actual VO_2 max testing data and applied to the model for oxygen consumption during exercise as well as converted into BTU/hr for a model input.
 - 5) Respiratory quotient/Respiratory Exchange Ratio (RER) - Historically a range of 0.87 - 0.92 has been found for CO_2 production. This quotient or ratio can rise to as high as 1 during intense exercise sessions. A team of Physiologists, Engineers and Scientists agreed on the RER for the model input taking into account that this is a critical element of crew health, especially while living in close quarters, and considering the expected level of activity.
 - 6) All four lunar crewmembers will be exercising because each crewmember needs to remain healthy throughout the entirety of the mission. Orion-ISS missions are not considered here as exercise is not required for those very short duration missions
 - 7) Vehicle Pressure - Described to the team by ECLSS as being 10.2 psia for planned standard Orion operating pressure in LEO and likely for transit phases, so this value was used as an input to the modeling.
 - 8) 0 g - There is only microgravity in space so this condition was used as an input to the model.
 - 9) Clothing - There are several thermodynamic models for the human system under certain conditions and stresses and these model predict different outcomes based on the amount of clothing. The model input for clothing is short sleeve t-shirt and shorts and the insulation and convection properties that apply to that clothing type were used in the modeling.
 - 10) Sleeping metabolic rate of 300 BTU/hr was agreed upon by a team of Physiologists, Engineers and Scientists and is within the range of historical data during non-wakeful activity.
 - 11) Nominal metabolic rate of 474 BTU/hr was agreed upon by a team of Physiologists, Engineers and Scientists and is within the range of historical data for typical Intravehicular Activity level.
 - 12) The 41-Node man model has been used and incorporated into NASA testing, verifications, validations since the 1960s and from different data analysis has shown to be accurate within 5% when similar constants and variables are chosen.

Suited Operations: Suited operations encompass a diverse set of activities that result in varied metabolic rates. Under certain conditions, the vehicle may need to support these metabolic loads through umbilical connections. Appendix E, table Crewmember Metabolic Rates For Suited Operations contains ranges of metabolic rates expected during suited operations, although this table will evolve as the operations concept matures. These data should therefore only be used as historical reference and in progress estimates, and not as design goals.

Revision: E	Document No: CxP 70024
Release Date: 11/19/10	Page: 401 of 503
Title: Constellation Program Human-Systems Integration Requirements	

TABLE E1-4 - CREWMEMBER METABOLIC RATES FOR SUITED OPERATIONS

Data Source	Minimum kJ/hr (BTU/hr)	Average kJ/hr (BTU/hr)	Maximum ⁽¹⁾ kJ/hr (BTU/hr)
μ Gravity EVA (ISS and STS)	575 (545) ⁽²⁾	950 (900) ⁽³⁾	2,320 (2,200)
Apollo Lunar Surface EVA	517 (490) ⁽²⁾	1,030 (980)	2,607 (2,471)
Advanced Walkback Test ⁽⁴⁾	1,767 (1,675) ⁽¹⁾	2,505 (2,374)	3,167 (3,002)
Suit Donning/Doffing	686 (650) ⁽⁵⁾	844 (800) ⁽⁵⁾	1,583 (1,500) ⁽⁶⁾
Assisting with Suit Doffing	-	686 (650) ⁽⁵⁾	-
Resting Postlanding 0 -1 hr	475 (450) ⁽⁷⁾	528 (500) ⁽⁸⁾	-
Resting Postlanding 1 -1.5 hr	422 (400) ⁽⁷⁾	617 (585) ⁽⁸⁾	-
Resting Postlanding 1.5 - 24 hr	369 (350) ⁽⁷⁾	477 (452) ⁽⁸⁾	-

(1) Transient condition less than 15 min in duration, individual instance
(2) Minimum average for low activity EVA durations
(3) Includes Orlan ISS EVAs, which trend to slightly higher metabolic rates
(4) Simulated 10 km (6.2 mile) lunar surface walk requiring 1-2 hours to complete, in case of rover failure, n=6
(5) Estimated metabolic rate representing moderate and lower effort portions of suit doffing; actual values may differ substantially dependent upon final suit and seat configurations
(6) Estimated peak metabolic rate based on historical Sokul suit egress data in Soyuz, representing the most difficult portion of suit doffing and not expected to be longer than 5-10 minutes total per crewmember
(7) Estimated resting metabolic rate in suits after landing on land or on calm seas without seasickness
(8) Estimated average metabolic rate assuming postlanding seasickness during water landings. Assume 2 out of the 4 crewmembers are sick.

When a crewmember is in a suit with no active cooling, heat storage may increase rapidly. JSC thermoregulatory models (Wissler and 41-Node man) simulating hot cabin entries wearing launch and entry suits with the thickness, conductance, wickability, and emissivity properties of the Advanced Crew Escape Suit (ACES) predicted loss of body cooling mechanisms. Data from military aircrew protective ensembles also found that body temperature increases more rapidly over time in pressure suits when compared to a shirt-sleeve environment. Appendix E, figure Time Allowed In Suit As Limited By Environmental Conditions And Activity Level Without Internal Garment Cooling, Wissler ACES Model provides the time allowance in a suit (without active cooling) prior to the onset of cognitive impairment.

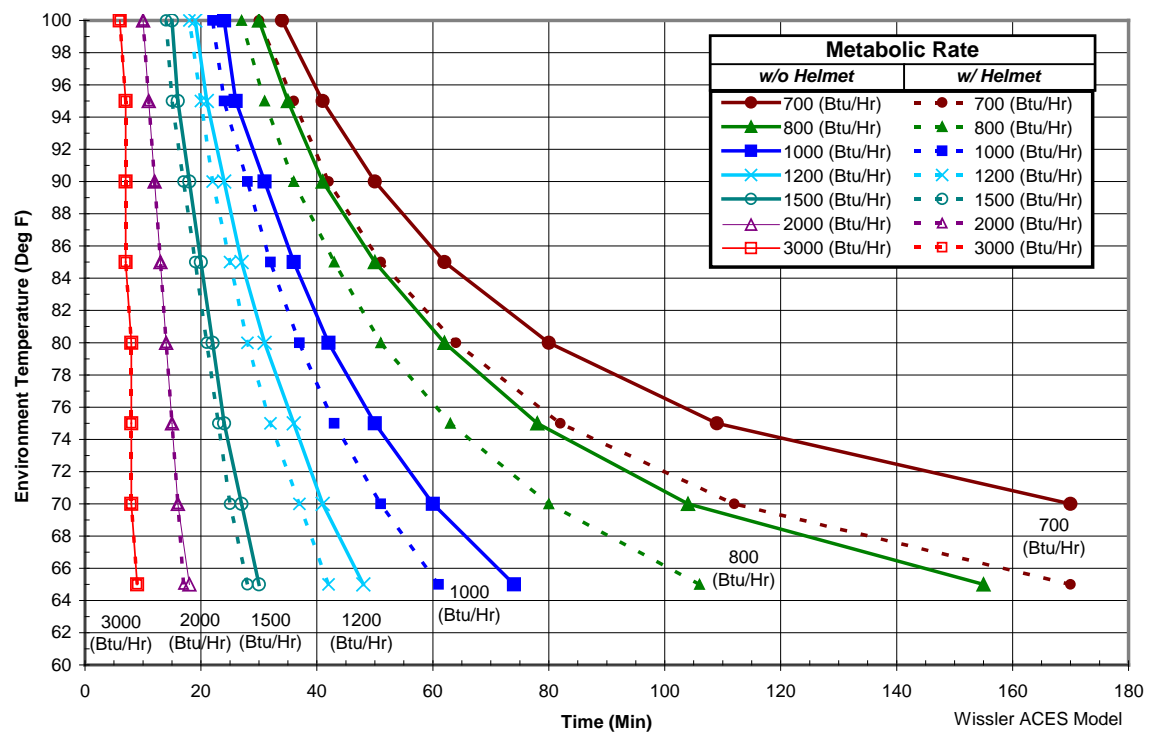


FIGURE E1-3 - TIME ALLOWED IN SUIT AS LIMITED BY ENVIRONMENTAL CONDITIONS AND ACTIVITY LEVEL WITHOUT INTERNAL GARMENT COOLING, WISSLER ACES MODEL

Revision: E	Document No: CxP 70024
Release Date: 11/19/10	Page: 403 of 503
Title: Constellation Program Human-Systems Integration Requirements	

APPENDIX F

F1.0

Appendix F content moved to Appendix A, Section A1.0 Acronyms and Abbreviations

Revision: E	Document No: CxP 70024
Release Date: 11/19/10	Page: 404 of 503
Title: Constellation Program Human-Systems Integration Requirements	

APPENDIX G

G1.0

Appendix G content moved to Appendix A, Section A2.0 Glossary of Terms.

Revision: E	Document No: CxP 70024
Release Date: 11/19/10	Page: 405 of 503
Title: Constellation Program Human-Systems Integration Requirements	

**APPENDIX H
TBD LIST**

TABLE H-1 - TO BE DETERMINED ITEMS

TBD	Location	Closure Plan	Target Date
TBD-70024-005	Appendix N, table Transient Force Applicant Limits	Tests will be performed by the Orion Contingency Land Landing Team to determine the limits for lumbar resultant forces in Appendix N, table Transient Force Application Limits, levied by HS3128 Transient Force Application Limits.	07/31/2010
TBD-70024-050	HS10028 HS10028V	Agreement between CxP, Projects, and Ground Operations is needed regarding ownership and maintenance of the CxP Launch Site Task Tool List.	07/31/2010

Revision: E	Document No: CxP 70024
Release Date: 11/19/10	Page: 406 of 503
Title: Constellation Program Human-Systems Integration Requirements	

**APPENDIX I
TBR LIST**

TABLE I-1 - TO BE RESOLVED ISSUES

TBR	Location.	Closure Plan	Target Date
TBR-70024-001	HS3129 HS3130 HS3130V	Tests will be performed by the Orion Contingency Land Landing Team to validate the limits for restrained body movement and deflection in Appendix N, table Restrained Body Movement and Deflection, levied by HS3130 Restrained Body Movement.	07/31/2010
TBR-70024-004	HS3006D HS3006DV	Additional research with vertebrate exposure to lunar dust required to determine the contaminant size.	12/31/2010
TBR-70024-005	HS11015 HS11016 HS11017 HS11018	Determine the need for Physiological Suited Parameters for the Table J-3 FFISS DRM.	06/30/2012

Revision: E	Document No: CxP 70024
Release Date: 11/19/10	Page: 407 of 503
Title: Constellation Program Human-Systems Integration Requirements	

APPENDIX J – Block 0 (Orion 1) DRM ALLOCATION MATRIX

This table denotes allocation of HSIR requirements to the various systems. An "X" in the column of any system for a given requirement allocates the requirement to that system. The system is either required to meet the requirement independently or in conjunction with other systems to which that requirement is allocated. Additionally, the last two columns denote which Verification Requirements must be satisfied with the verification requirements contained within the HSIR, Section 4.0 (those marked LII), OR which may be verified using alternate acceptable methods that have been Level III Project approved and documented (those marked LIII). The Level III projects are not required to obtain approval for verification closure or changes to verification methodology beyond their own project boards when verification has been designated Level III. Designation of Level II verification denotes that the Level II Program dictates and maintains change authority over the verification methodology but does not necessarily imply that Level II performs the verification.

The Block 0 (Orion 1) Design Reference Mission (DRM) is a “Low Earth Orbit (LEO) Uncrewed” DRM. This mission’s primary purpose is to provide a low-earth orbit (LEO) spacecraft system demonstration capability. It will provide an uncrewed test bed for subsystems to execute in-space objectives and validate the initial capabilities of the Orion spacecraft. Although the spacecraft system will not contain a flight crew during this DRM, its systems will still be assembled, operated, and serviced by various ground crew personnel. Requirements applicable to the Block 0 (Orion 1) DRM can be found in Table J-1 – Allocation Matrix for Block 0 (Orion 1) DRM. Note that Table J-1 is only applicable for the DRM described herein. The Block 0 (Orion 1) DRM applicability matrix is intended to protect the health and safety of ground maintenance and recovery crew, not to specifically scope the configuration of the Orion 1 vehicle or identify flight test objectives for Orion 2.

Additional HSIR functional and design and construction requirements may be met by the Orion 1 design, either through flight test objectives or as a result of common manufacturing and tooling with later Orion flights. However, verification for these requirements are not explicitly required unless allocated in this matrix.

As stated above, Orion 1 is an uncrewed mission with a duration of 14 (TBR) days. Flight Day 1 includes launch, LEO reconfiguration, and test operations. Test operations continue through the mission until Flight Day 14. On Flight Day 14, the vehicle will de-orbit, re-enter the Earth’s atmosphere, land (San Diego), then be recovered. Key operational assumptions include: (*Source of Block 0 (Orion 1) DRM description: 04/29/10 ERB Presentation*)

- 0 crew
- The launch vehicle is Ares I
- The exact mission duration will be designed to accomplish the test objectives within the consumables and thermal limitations of the spacecraft

Revision: E	Document No: CxP 70024
Release Date: 11/19/10	Page: 412 of 503
Title: Constellation Program Human-Systems Integration Requirements	

REQUIREMENTS								VERIFICATIONS	
Requirement	Requirement Name	Orion	Ares I	MS	GO	EVA	FCE	LEVEL II	LEVEL III
	Maintenance								
HS4004	Corners and Edges of Loose Equipment								
HS4005	Burrs	X							
HS4006	Sharp Items								
HS4007	Interior Item Restraints								
HS4008	Electrical Hazard Potential								
HS4008B	Chassis Leakage Current - Nonpatient Equipment								
HS4008C	Chassis Leakage Current - Patient Equipment								
HS4012	Hot Touch Temperature Limit								
HS4012A	Cold Touch Temperature Limit								
HS4019	Fire Suppression Portability								
HS4021	Pinch Points								
HS4022	Emergency Equipment Access								
HS4023	Holes								
HS5001	Layout Interference								
HS5002	Layout Sequential Operations								
HS5003	Workstation Orientation								
HS5004	Ingress and Egress Translation Paths								
HS5005	Internal Translation Paths								
HS5006	Standard Restraints and Mobility Aids								
HS5007	IVA Mobility Aids								
HS5008	Workstation Restraints								
HS5009	Ingress and Egress Mobility Aids								
HS5010	Crew Egress Translation Path - Ground								
HS5012	Flail Injury Protection								
HS5013	Hatches Operable Inside and Outside	X			X				X
HS5014	Hatch Manual Pressure Equalization Inside and Outside	X							X
HS5016	Hatch Closure Indication	X							X
HS5017	Hatch Visual Observation	X							X
HS5019	Window Optical Properties								
HS5021	Window Viewing for Piloting Tasks								
HS5022	Window for External Viewing Observation								
HS5027	Window Cover, Shade, and Filter Removal or Replacement in 10 Seconds								
HS5030	Obstruction								
HS5031	Window and Internal Darkening								
HS5032	Window Proximity Finishes								
HS5034B	Interior Light Adjustability								
HS5035	Lighting Level by Task	X							X
HS5039	General Light Control	X							X
HS5040	Workstation Light Control	X							X
HS5041	Workstation Light Position Adjustment	X							X

Revision: E	Document No: CxP 70024
Release Date: 11/19/10	Page: 415 of 503
Title: Constellation Program Human-Systems Integration Requirements	

REQUIREMENTS								VERIFICATIONS	
Requirement	Requirement Name	Orion	Ares I	MS	GO	EVA	FCE	LEVEL II	LEVEL III
HS7003	Handling Qualities for Manual Control – Level 1								
HS7004	Handling Qualities for Manual Control – Level 2								
HS7007	Consistent Crew Interfaces								
HS7009	Location Coding								
HS7010	Field of View								
HS7010A	Two-Crew Operations								
HS7018	Viewing Critical Displays and Controls								
HS7018A	Viewing Frequently Used Displays and Controls								
HS7019	Functional Reach Envelope								
HS7021	Reach for Critical Controls								
HS7021A	Reach for Frequently Used Controls								
HS7022	Functional Related Displays and Controls								
HS7023	Successive Operation of Displays and Controls								
HS7024	Control Spacing For Suited Operations								
HS7027	Over 3 g								
HS7028	Over 2 g								
HS7029	Supports								
HS7036	Labeling	X					X	X	
HS7044	Legibility								
HS7049	Notifications	X							X
HS7049A	Manual Silencing	X							X
HS7055	Command Feedback								
HS7058	Subsystem State Information	X							X
HS7058A	System Responsiveness for Discrete Inputs	X							X
HS7058B	System Responsiveness for Continuous Inputs								
HS7058C	Request for Information								
HS7058D	Request for Critical Information								
HS7058E	Menu Update Time								
HS7059	Task-Oriented Displays								
HS7060	Subsystem-Oriented Displays								
HS7060A	Viewing Simultaneous Task Information								
HS7061	Location within the Display Hierarchy								
HS7063	Compatibility of Movement								
HS7063A	Control Feedback								
HS7063B	Protection against Inadvertent Activation								
HS7063C	Protection for Flight Actuated Critical Controls	X							X
HS7063D	Coding for Emergency Controls	X							X
HS7063E	Restraints for Control Operation								
HS7064	Language								
HS7065A	Use of Color								
HS7066	Crew Interface Usability								
HS7067	Obscured Controls								
HS7070	Viewing Simultaneous	X							X

Revision: E	Document No: CxP 70024
Release Date: 11/19/10	Page: 417 of 503
Title: Constellation Program Human-Systems Integration Requirements	

REQUIREMENTS								VERIFICATIONS	
Requirement	Requirement Name	Orion	Ares I	MS	GO	EVA	FCE	LEVEL II	LEVEL III
	Indication								
HS8047	Unique Identification Labeling								
HS8048	Visual Line of Sight								
HS8051	Condensation Prevention on Interior Surfaces	X							X
HS8052	Tool Clearance								
HS8053	Disturbance of Equipment								
HS8054	Tool Usage								
HS8055	Crew Control of Power								
HS9014	Data Rate								
HS9018	Locations of Data								
HS9019	Wired Network	X							X
HS9020	Wireless Network								
HS9021	Crew Operability	X							X
HS9025	Displaying Electronic Procedures System	X							X
HS9025A	Cueing Electronic Procedures System	X							X
HS9026	Current Procedure Step	X							X
HS9027	Completed Procedure Steps	X							X
HS9028	Crew Notification of Required Procedure Action	X							X
HS9029	Annunciation Hierarchy	X							X
HS9029A	Annunciation Prioritization	X							X
HS9030	Visual and Auditory Annunciation	X							X
HS9032	Distinctiveness of Annunciations	X							X
HS9032A	Loss of Annunciation Capability	X						X	
HS9037	Decomposition of Chemicals	X					X		X
HS9040	Data Fidelity	X							X
HS9042A	Manual Information Capture and Transfer								
HS10001	Maintainability Without Deintegration								
HS10002	Work Envelope Volumes	X	X						X
HS10004	Reach Envelope Volumes	X	X						X
HS10006	Ground Crew Visual Access	X	X						X
HS10008	Ground Anthropometry, Biomechanics, and Strength	X	X					X	
HS10009	Maintainability Without Disabling Subsystems								
HS10010	Fuse/Circuit Indication	X	X						X
HS10011	Appropriate Clothing and Equipment	X	X						X
HS10012	LRU Installation	X	X						X
HS10013	LRU Mounting/Alignment Labels/Codes	X	X						X
HS10014	LRU Interchangeability	X	X						X
HS10015	Connector Mismatching	X	X						X
HS10017	Connector Mating Labels	X	X						X
HS10019	Maintenance Without Damage	X	X						X
HS10020	Fluid Management	X	X						X
HS10021	Fluid Spillage Control	X	X						X
HS10022	System Safing Controls	X	X						X

Revision: E	Document No: CxP 70024
Release Date: 11/19/10	Page: 420 of 503
Title: Constellation Program Human-Systems Integration Requirements	

APPENDIX J – Block 0 (Orion 2) DRM ALLOCATION MATRIX

This table denotes allocation of HSIR requirements to the various systems. An "X" in the column of any system for a given requirement allocates the requirement to that system. The system is either required to meet the requirement independently or in conjunction with other systems to which that requirement is allocated. Additionally, the last two columns denote which Verification Requirements must be satisfied with the verification requirements contained within the HSIR, Section 4.0 (those marked LII), OR which may be verified using alternate acceptable methods that have been Level III Project approved and documented (those marked LIII). The Level III projects are not required to obtain approval for verification closure or changes to verification methodology beyond their own project boards when verification has been designated Level III. Designation of Level II verification denotes that the Level II Program dictates and maintains change authority over the verification methodology but does not necessarily imply that Level II performs the verification.

The Block 0 (Orion 2) Design Reference Mission (DRM) is an “Optimized ISS Flight Day 1” DRM. The Optimized ISS FD1 DRM provides an initial crewed capability to ISS demonstration. The mission provides a proving ground for advanced systems. The requirements applicable to the Block 0 (Orion 2) DRM can be found in Table J-2 – Allocation Matrix for Block 0 (Orion 2) DRM. Note that Table J-2 is only applicable for the DRM described herein.

As stated above, Orion 2 is a crewed mission flying 2 crewmembers to ISS on a mission lasting 9 flight days. Flight Day 1 includes launch, LEO reconfiguration, and ISS Rendezvous and docking. Flight days 2 through 8 include ISS attached operations, an MMOD video survey to check for any damage to the vehicle, and entry systems checkout. On Flight Day 9, the vehicle will undock from ISS, de-orbit, re-enter the Earth’s atmosphere, land (San Diego), then be recovered. Note: that mission variations include as early as a Flight Day 5 undock, and as late as a Flight Day 14 undock). Key operational assumptions include:

(Source of Block 0 (Orion 2) DRM description: ERB 10-0565 Presentation, 4/29/2010)

- 2 crew (vehicle is designed to hold up to 4 crew)
- The launch vehicle is Ares I
- Inclination is 51.6 degrees
- The planned ISS undock & deorbit will provide for a next day (End of Mission (EOM) +1) deorbit opportunity to the primary landing zone
- Contingency duration (hours) beyond EOM+1 will be allocated to pre-ISS dock troubleshooting and ISS safe haven
- Crew remains suited during all mission phases with visors down during ascent docking and entry activity operations
- Crew may temporarily doff suits (remaining in Liquid Cooling Garment (LCG)) *
- Crew remains suited and seated during nominal recovery

Revision: E	Document No: CxP 70024
Release Date: 11/19/10	Page: 421 of 503
Title: Constellation Program Human-Systems Integration Requirements	

- Suit/FCE provides waste management function **
- Automated functionality is provided to support time-critical mission success and crew safety capabilities (functionality outside this boundary can be deferred to the crew and/or the ground to execute).
- The automated capabilities should support autonomous (crew + vehicle) operation for up to 1 hour in the event of loss of ground communication
- Docking and ISS interfaces are compatible with the Low Impact Docking System (LIDS) docking mechanism
- Redundant components will be active during all mission critical activities
- MMOD inspection will occur but tile repair will not be performed
- Vehicle will transmit location signal for recovery
- CM will be recovered for post mission inspection & analysis
- ISS attached ops duration will be tailored for landing site availability

* Partial doffing of the LCG will be necessary to accommodate hygiene operations and to perform MAG (diaper) change-out.

** MAG usage due to Waste Management System deferral is accepted by the Program as a one-time risk for the Orion 2 Flight Day 1 docking test flight only, and not considered the norm for fully functional operations, follow-on test flights, or multi-day flights.

TABLE J-2 - ALLOCATION MATRIX FOR BLOCK 0 (ORION 2) DRM

REQUIREMENTS								VERIFICATIONS	
Requirement	Requirement Name	Orion	Ares I	MS	GO	EVA	FCE	LEVEL II	LEVEL III
HS2001	Anthropometric Dimensions for Unsuiting Crewmembers	X				X	X		X
HS2002	Anthropometric Dimensions for Suited Crewmembers	X			X	X	X		X
HS2003	Range of Motion of an Unsuiting Crewmember	X				X	X		X
HS2004	Range of Motion of a Suited Crewmember	X			X	X	X		X
HS2005	Mass Properties of an Unsuiting Crewmember	X				X	X		
HS2006	Mass Properties of a Suited Crewmember	X			X	X	X		X
HS2007	Structural Integrity of Hardware for an Unsuiting Crewmember	X				X	X		X
HS2007B	Structural Integrity of Hardware for a Suited Crewmember	X			X	X	X		
HS2008	Minimum Crew Operational Loads for an Unsuiting Crewmember	X				X	X		X
HS2008B	Minimum Crew	X			X	X	X		

Revision: E	Document No: CxP 70024
Release Date: 11/19/10	Page: 422 of 503
Title: Constellation Program Human-Systems Integration Requirements	

REQUIREMENTS								VERIFICATIONS	
Requirement	Requirement Name	Orion	Ares I	MS	GO	EVA	FCE	LEVEL II	LEVEL III
	Operational Loads for a Suited Crewmember								
HS2009	Equipment Damage Hazard	X				X	X		X
HS2010	Total Crew Control Mass	X							X
HS3001	O2 and Total Pressure Control	X		X				X	
HS3004	Total Pressure for Nominal Vehicle Operations	X							X
HS3004B	O2 Partial Pressure for Nominal Vehicle Operations	X							X
HS3004C	CO2 Partial Pressure for Nominal Vehicle Operations	X				X			X
HS3004D	N2 Partial Pressure for Nominal Vehicle Operations								
HS3005	Total Pressure Tolerance Ranges for Crew Exposure	X				X			X
HS3005B	O2 Partial Pressure Tolerance Ranges for Crew Exposure	X				X			X
HS3005C	CO2 Partial Pressure Tolerance Ranges for Crew Exposure	X				X			X
HS3006	Microbial Air Contamination	X							X
HS3006C	Particulate Contamination	X				X			X
HS3006D	Lunar Dust Contamination								
HS3007	Gaseous Pollutants Limits	X				X	X		X
HS3009	Rate of Change of Pressure Limits	X				X			X
HS3012A	Combustion Products Monitoring	X					X		X
HS3012B	Combustion Products Measurement	X					X		X
HS3012D	Carbon Monoxide Alert	X							X
HS3013	Composition Reporting	X							X
HS3014	Composition Alerting	X							X
HS3015	Toxic Hazard Level 3	X				X	X		X
HS3015A	Toxic Hazard Level 4	X	X			X	X		X
HS3016	Personal Protective Equipment						X		X
HS3017	Crew Communication During Contingency Breathing	X					X		X
HS3017A	Contingency Breathing Apparatus						X		X
HS3017B	Mission Systems Communication During Contingency Breathing	X		X			X		X
HS3019	Physiochemical Limits for Potable Water				X	X	X	X	
HS3019A	Microbial Limits for				X	X	X		X

Revision: E	Document No: CxP 70024
Release Date: 11/19/10	Page: 423 of 503
Title: Constellation Program Human-Systems Integration Requirements	

REQUIREMENTS								VERIFICATIONS	
Requirement	Requirement Name	Orion	Ares I	MS	GO	EVA	FCE	LEVEL II	LEVEL III
	Potable Water								
HS3025	Potable Water for On-Orbit Drinking						X		X
HS3026	Potable Water for Fluid Loading						X		X
HS3027	Potable Water for Post-Landing	X					X		X
HS3028	Potable Water for Personal Hygiene						X		X
HS3029	Potable Water Rate								
HS3030	Potable Water Temperature for Cold Drinks								
HS3031	Potable Water Temperature for Hot Food and Drinks								
HS3032	Potable Water Temperature for Personal Hygiene								
HS3034	Water Sampling				X				X
HS3036	Nominal Atmospheric Temperature	X							X
HS3037	Contingency Control of Heat Stored by Crewmembers	X				X		X	
HS3046	Relative Humidity for Nominal Vehicle	X							X
HS3047	In-flight Ventilation	X							X
HS3050	Supplemental Ventilation	X							X
HS3051	Temperature Set-Point Adjustment	X							X
HS3052	Temperature Set-Point Accessibility	X							X
HS3053	Temperature Set-Point Increments	X							X
HS3054	Temperature Set-Point Error	X							X
HS3055	Display and Monitoring of Temperature and Relative Humidity	X							X
HS3059	Crew Exposure to Rate of Change of Acceleration	X	X		X				X
HS3060	Linear Acceleration Limits during Nominal Return	X							X
HS3061	Linear Acceleration Limits from Launch to Mission Destination	X	X					X	
HS3062	Linear Acceleration Limits for Ascent Abort and Off-Nominal	X	X					X	
HS3064	Crew Injury Risk Limits	X				X		X	
HS3065	Sustained Rotational Acceleration Limit	X	X					X	
HS3069	Rotational Limits for Nominal Return	X							X
HS3070	Rotational Limits for Launch to Mission Destination	X	X					X	

Revision: E	Document No: CxP 70024
Release Date: 11/19/10	Page: 424 of 503
Title: Constellation Program Human-Systems Integration Requirements	

REQUIREMENTS								VERIFICATIONS	
Requirement	Requirement Name	Orion	Ares I	MS	GO	EVA	FCE	LEVEL II	LEVEL III
HS3071	Rotational Limits for Ascent Abort and Off-Nominal Entry	X	X					X	
HS3072	Hazardous Noise Limit for Launch and Entry	X	X			X		X	
HS3073	Noise Dose Limits for Launch and Entry	X	X			X		X	
HS3074	Impulse Noise Limit for Launch and Entry	X	X			X		X	
HS3075	Hazardous Noise Limit for the Orbit Phase	X				X	X		X
HS3076	Sound Pressure Level (SPL) Limits for Continuous Noise during Orbit Phase	X				X	X	X	
HS3078	Impulse Noise Limit for the Orbit Phase	X				X	X		X
HS3079	Annoyance Noise Limits for Crew Sleep								
HS3080	Tonal and Narrow-Band Noise Limits	X				X	X	X	
HS3081	Infrasonic Noise Limits	X	X					X	
HS3082	Cabin Depressurization Valve Hazardous Noise Limit	X				X		X	
HS3083	Cabin Depressurization Valve Noise Dose Limits	X				X		X	
HS3084	Reverberation Time	X							X
HS3085	Radiation Design Requirements	X						X	
HS3086	Charged Particle Monitoring								
HS3088	Dose Equivalent Monitoring								
HS3089	Absorbed Dose Monitoring								
HS3090	Passive Radiation Monitoring	X					X		X
HS3091	Radiation Data Reporting to the Crew - Absorbed Dose								
HS3092	Alerting for Radiation Data								
HS3093	Radio-Frequency Electromagnetic Field Radiation Limits	X	X		X		X	X	
HS3094	Ocular Exposure to Lasers	X	X		X		X	X	
HS3096	Dermal Exposure to Lasers	X	X		X		X	X	
HS3098	Retinal Thermal Injury from Visible and Near Infrared Sources	X			X		X	X	
HS3099	Small Source Visible Radiation Limits	X			X		X	X	
HS3101	Large Source Visible Radiation Limits	X			X		X	X	
HS3103	Thermal Injury from Infrared Radiation	X			X		X	X	
HS3104	Ultraviolet Exposure for Unprotected Eye or	X			X		X	X	

Revision: E	Document No: CxP 70024
Release Date: 11/19/10	Page: 425 of 503
Title: Constellation Program Human-Systems Integration Requirements	

REQUIREMENTS								VERIFICATIONS	
Requirement	Requirement Name	Orion	Ares I	MS	GO	EVA	FCE	LEVEL II	LEVEL III
	Skin								
HS3105	Health Limits for Vibration During Dynamic Phases of Flight	X	X			X		X	
HS3106	Vibration Limits during Crew Sleep	X						X	
HS3108	Pre-Launch Vibration Limit to Prevent Motion Sickness	X	X		X			X	
HS3109	Sound Pressure Level (SPL) Limits for Intermittent Noise Duration	X					X		X
HS3110	Noise Limit for Personal Communication Devices	X				X	X	X	
HS3111	Loudspeaker Alarm Audibility	X						X	
HS3112	Radiation Data Reporting to Mission Systems - Absorbed Dose								
HS3113	Particle Archive Data								
HS3114	Ventilation Adjustment	X							X
HS3115	Display of Actual Temperature	X							X
HS3116	Display of Temperature Set-Point	X							X
HS3117	Potable Water Dispensing								
HS3118	Potable Hot Water Quantity for Rehydration								
HS3119	Radiation Data Reporting to the Crew - Dose Equivalent								
HS3120	Radiation Data Reporting to Mission Systems - Dose								
HS3121	Potable Water Temperature for Medical Use								
HS3122	Potable Water for Medical Use						X		X
HS3123	Potable Water for Medical Contingency						X		X
HS3124	Head Protection Criteria	X				X			
HS3125	Neck Protection Criteria	X				X			
HS3126	Relative Humidity Tolerance Ranges for Crew Exposure	X				X			X
HS3127	Potable Water for On-Orbit Food Rehydration						X		X
HS3128	Transient Force Application Limits	X				X			
HS3129	Chest Deflection	X				X			
HS3130	Restrained Body Movement	X				X		X	

Revision: E	Document No: CxP 70024
Release Date: 11/19/10	Page: 426 of 503
Title: Constellation Program Human-Systems Integration Requirements	

REQUIREMENTS								VERIFICATIONS	
Requirement	Requirement Name	Orion	Ares I	MS	GO	EVA	FCE	LEVEL II	LEVEL III
HS3132	Head Transient Acceleration Limits	X				X			
HS3133	Sound Pressure Level (SPL) Limits for Waste Management System								X
HS3134	Speech Interference Level Limit for Pre-Launch and Post-Landing	X				X			X
HS4002	Corners and Edges Exposed during Nominal Operations	X			X	X	X		X
HS4003	Corners and Edges Exposed during Maintenance	X				X	X		X
HS4004	Corners and Edges of Loose Equipment	X				X	X		X
HS4005	Burrs	X			X	X	X		X
HS4006	Sharp Items	X			X	X	X		X
HS4007	Interior Item Restraints	X				X	X		X
HS4008	Electrical Hazard Potential	X				X	X		X
HS4008B	Chassis Leakage Current - Nonpatient Equipment	X				X	X		X
HS4008C	Chassis Leakage Current - Patient Equipment								
HS4012	Hot Touch Temperature Limit	X				X	X		X
HS4012A	Cold Touch Temperature Limit	X				X	X		X
HS4019	Fire Suppression Portability	X					X		X
HS4021	Pinch Points	X			X	X	X		X
HS4022	Emergency Equipment Access	X			X	X	X		X
HS4023	Holes	X			X	X	X		X
HS5001	Layout Interference	X							
HS5002	Layout Sequential Operations	X							
HS5003	Workstation Orientation	X							X
HS5004	Ingress and Egress Translation Paths	X						X	
HS5005	Internal Translation Paths	X							X
HS5006	Standard Restraints and Mobility Aids	X					X		
HS5007	IVA Mobility Aids	X					X		X
HS5008	Workstation Restraints	X							X
HS5009	Ingress and Egress Mobility Aids	X			X			X	
HS5010	Crew Egress Translation Path - Ground	X			X				X
HS5012	Flail Injury Protection	X				X		X	
HS5013	Hatches Operable Inside and Outside	X			X				X
HS5014	Hatch Manual Pressure Equalization Inside and	X							X

Revision: E	Document No: CxP 70024
Release Date: 11/19/10	Page: 427 of 503
Title: Constellation Program Human-Systems Integration Requirements	

REQUIREMENTS								VERIFICATIONS	
Requirement	Requirement Name	Orion	Ares I	MS	GO	EVA	FCE	LEVEL II	LEVEL III
	Outside								
HS5016	Hatch Closure Indication	X							X
HS5017	Hatch Visual Observation	X							X
HS5019	Window Optical Properties	X							X
HS5021	Window Viewing for Piloting Tasks	X							X
HS5022	Window for External Viewing Observation	X							X
HS5027	Window Cover, Shade, and Filter Removal or Replacement in 10 Seconds	X							X
HS5030	Obstruction	X							
HS5031	Window and Internal Darkening	X							X
HS5032	Window Proximity Finishes	X							X
HS5034B	Interior Light Adjustability	X							X
HS5035	Lighting Level by Task	X					X		X
HS5039	General Light Control	X							X
HS5040	Workstation Light Control	X							X
HS5041	Workstation Light Position Adjustment	X							X
HS5042	Workstation Visual Demarcations	X							X
HS5043	Hatches Operable in 60 Seconds	X			X				X
HS5044	Hatches Operable Without Tools	X			X				X
HS5045	Hatches Operable by Suited Crewmembers	X							X
HS5046	Unlatching Hatches	X							X
HS5048	Hatch Manual Pressure Equalization by Suited Crewmembers	X							X
HS5049	Hatch Latch Position	X							X
HS5050	Hatch Pressure Difference Measurement	X							X
HS5051	Window Cover, Shade, and Filter Removal or Replacement Without Tools	X							X
HS5052	Commonly Distinguishable Handrails	X							
HS5053	Crew Ingress/Egress Translation Path in Space	X						X	
HS5054	Egress Handrails	X			X				
HS5055	Window for Motion Imagery and Photography	X							X
HS5056	Lighting ON/OFF Control	X							X
HS6001	Cross-Contamination	X							

Revision: E	Document No: CxP 70024
Release Date: 11/19/10	Page: 428 of 503
Title: Constellation Program Human-Systems Integration Requirements	

REQUIREMENTS								VERIFICATIONS	
Requirement	Requirement Name	Orion	Ares I	MS	GO	EVA	FCE	LEVEL II	LEVEL III
	Prevention								
HS6002	Cross-Contamination Separation	X							
HS6003	Heating								
HS6004	Rehydration								X
HS6005	In-Flight Food Preparation Time						X		
HS6009	Personal Hygiene Privacy								
HS6010	Personal Hygiene Stowage	X							
HS6012	Personal Hygiene Trash	X							
HS6013	Vomitus Collection and Containment	X					X		X
HS6014	Simultaneous Defecation and Urination					X			X
HS6016	Fecal Wipes					X			X
HS6017	Feces per Day					X			X
HS6020	Diarrhea per Event					X			X
HS6020C	Feces per Event					X			X
HS6020D	Diarrheal Events per Crewmember					X			X
HS6021	Urine Collection					X			X
HS6022	Urine Wipes								X
HS6023	Urine per Crewmember					X			X
HS6024	Urine per Hour					X			X
HS6025	Urine Rate					X			X
HS6025B	Urine per Day					X			X
HS6027	Full Body Visual Privacy								X
HS6028	Body Self-Inspection and Cleaning	X							
HS6029	Waste Management Odor Control						X		X
HS6030	Waste Management Stowage								
HS6031	Waste Management Trash						X		
HS6032	Exercise Capability								
HS6035	Exercise Operational Envelope								
HS6036	Thermal Environment During Exercise								
HS6037	Carbon Dioxide Levels During Exercise								
HS6038	Relative Humidity During Exercise								
HS6044	Stowage Nominal Operation	X							
HS6046	Stowage Location	X							
HS6047	Stowage Arrangement	X					X		
HS6049	Stowage Reconfiguration	X							
HS6050	Stowage Restraints	X					X		X
HS6051	Stowage Hand Operation	X					X		X
HS6052	Stowage Commonality	X					X		

Revision: E	Document No: CxP 70024
Release Date: 11/19/10	Page: 429 of 503
Title: Constellation Program Human-Systems Integration Requirements	

REQUIREMENTS								VERIFICATIONS	
Requirement	Requirement Name	Orion	Ares I	MS	GO	EVA	FCE	LEVEL II	LEVEL III
HS6053	Stowage Compatibility with Inventory Management								
HS6054	Trash Management Nominal Operations	X							
HS6056	Trash Management Odor Control						X		X
HS6057	Trash Management Contamination Control	X					X		X
HS6058	Trash Management Hazard Containment	X					X		X
HS6059	Food System						X	X	
HS6060	Metabolic Intake						X	X	
HS6062	Metabolic Intake for EVA						X	X	
HS6063	Potable Water for EVA Operations								
HS6069	Auditory and Olfactory Privacy								
HS6073	Oxygen Levels During Exercise								
HS6075	Private Voice	X		X	X				X
HS6076	Private Video								
HS6077	Biomedical Data								
HS6078	Biomedical Relay								
HS6079	Biomedical Display								
HS6081	DCS Over-Pressurization	X						X	
HS6082	Orthostatic Protection	X				X			X
HS6083	Medical Care Provider Access	X							X
HS6084	Patient Electrical Isolation								
HS6085	Access to Medical Equipment	X							X
HS6086	Access to Deployed Medical Kits	X							X
HS6091	Denitrogenation	X				X		X	
HS6097	Communication Capabilities								X
HS6099	Personalized In-Flight Updates								
HS6100	DCS Event Pressure	X						X	
HS6101	Medical Care Capabilities					X	X	X	
HS6102	Lunar Surface Food Preparation Time								
HS6104	Crew Sleep Accommodations	X							X
HS6105	Personal Hygiene Items						X		X
HS6106	Stowage Equipment Cover Restraint	X					X		X
HS7003	Handling Qualities for Manual Control – Level 1	X						X	
HS7004	Handling Qualities for Manual Control – Level 2	X						X	
HS7007	Consistent Crew	X				X			

Revision: E	Document No: CxP 70024
Release Date: 11/19/10	Page: 430 of 503
Title: Constellation Program Human-Systems Integration Requirements	

REQUIREMENTS								VERIFICATIONS	
Requirement	Requirement Name	Orion	Ares I	MS	GO	EVA	FCE	LEVEL II	LEVEL III
	Interfaces								
HS7009	Location Coding	X							X
HS7010	Field of View	X				X			X
HS7010A	Two-Crew Operations	X							X
HS7018	Viewing Critical Displays and Controls	X			X				
HS7018A	Viewing Frequently Used Displays and Controls	X							
HS7019	Functional Reach Envelope	X			X				X
HS7021	Reach for Critical Controls	X							
HS7021A	Reach for Frequently Used Controls	X							
HS7022	Functional Related Displays and Controls	X							
HS7023	Successive Operation of Displays and Controls	X							
HS7024	Control Spacing For Suited Operations	X				X			X
HS7027	Over 3 g	X							X
HS7028	Over 2 g	X							X
HS7029	Supports	X							X
HS7036	Labeling	X				X	X	X	
HS7044	Legibility	X				X	X		X
HS7049	Notifications	X							X
HS7049A	Manual Silencing	X							X
HS7055	Command Feedback	X							X
HS7058	Subsystem State Information	X							X
HS7058A	System Responsiveness for Discrete Inputs	X							X
HS7058B	System Responsiveness for Continuous Inputs	X							
HS7058C	Request for Information	X							
HS7058D	Request for Critical Information	X							X
HS7058E	Menu Update Time	X							X
HS7059	Task-Oriented Displays	X							X
HS7060	Subsystem-Oriented Displays	X							X
HS7060A	Viewing Simultaneous Task Information	X							
HS7061	Location within the Display Hierarchy	X							X
HS7063	Compatibility of Movement	X				X			X
HS7063A	Control Feedback	X				X			X
HS7063B	Protection against Inadvertent Activation	X				X			
HS7063C	Protection for Flight Actuated Critical Controls	X				X			X
HS7063D	Coding for Emergency Controls	X				X			X

Revision: E	Document No: CxP 70024
Release Date: 11/19/10	Page: 431 of 503
Title: Constellation Program Human-Systems Integration Requirements	

REQUIREMENTS								VERIFICATIONS	
Requirement	Requirement Name	Orion	Ares I	MS	GO	EVA	FCE	LEVEL II	LEVEL III
HS7063E	Restraints for Control Operation	X							X
HS7064	Language	X			X	X	X		X
HS7065A	Use of Color	X				X	X		X
HS7066	Crew Interface Usability	X				X		X	
HS7067	Obscured Controls	X				X			X
HS7070	Viewing Simultaneous Critical Task Information	X							X
HS7071	Access within the Display Hierarchy	X							
HS7072	State Change	X						X	
HS7072A	Lost Data	X							X
HS7075	Volume Control for Auditory Annunciations	X							X
HS7076	Speech Intelligibility	X		X	X	X			X
HS7077	Volume Control for Audio Communications	X							X
HS7079	Nomenclature	X				X	X	X	
HS7080	Workload Measure: Nominal	X				X		X	
HS7080A	Workload Measure: Off-Nominal	X				X		X	
HS7082	Self-Illuminated Controls and Displays	X							X
HS7083	Protection for Ground Actuated Critical Controls			X	X				X
HS7925	Control Spacing for Unsited Operations	X							X
HS8001	ORU Change-out	X					X		X
HS8002	Maintenance Time per Day	X							X
HS8003	ORU Maintenance Time	X							X
HS8003-Objective	ORU Replacement Time/Maintenance	X							
HS8004	LRU Removal and Replacement	X	X						
HS8005	Physical Features	X				X	X		X
HS8006	Labeling and Marking	X				X	X		X
HS8007	Interchangeability	X							X
HS8008	Connectors	X				X	X		X
HS8009	Visual Access	X				X			X
HS8010	Physical Access	X							X
HS8011	Cable Access	X	X						X
HS8013	External Service Points								
HS8015	Maintenance Hazard	X				X	X		X
HS8016	Failure Notification	X							X
HS8017	No Fuses for Dynamic Flight Phases	X							X
HS8018	Circuit Breakers Instead of Fuses	X							
HS8020	Replacement Without Tools	X							X
HS8021	Replacement Without Component Removal	X							X

Revision: E	Document No: CxP 70024
Release Date: 11/19/10	Page: 432 of 503
Title: Constellation Program Human-Systems Integration Requirements	

REQUIREMENTS								VERIFICATIONS	
Requirement	Requirement Name	Orion	Ares I	MS	GO	EVA	FCE	LEVEL II	LEVEL III
HS8022	Circuit Breaker Resetting	X							X
HS8023	Trip Indication	X							X
HS8024	Electrostatic Discharge	X					X		X
HS8026	Access Points	X				X			
HS8029	Fastener Heads	X				X	X		X
HS8030	Fastener Number and Variety	X				X	X		
HS8031	Captive Fasteners	X				X	X		X
HS8032	Equipment Isolation	X							X
HS8034	Hazardous Levels of Fluid Leakage	X							X
HS8037	Common Toolset	X				X	X		
HS8041	Microbial Contamination	X				X	X		X
HS8042	Fungal Contamination	X				X	X		X
HS8043	Replacement of Air Filters	X							
HS8045	Visual Indication	X				X	X		X
HS8046	Connector Mating Indication	X				X	X		X
HS8047	Unique Identification Labeling	X				X	X	X	
HS8048	Visual Line of Sight	X	X						
HS8051	Condensation Prevention on Interior Surfaces	X							X
HS8052	Tool Clearance	X				X	X		X
HS8053	Disturbance of Equipment	X							
HS8054	Tool Usage	X				X	X		X
HS8055	Crew Control of Power	X							X
HS9014	Data Rate	X							
HS9018	Locations of Data	X							X
HS9019	Wired Network	X							X
HS9020	Wireless Network								
HS9021	Crew Operability	X							X
HS9025	Displaying Electronic Procedures System	X							X
HS9025A	Cueing Electronic Procedures System	X							X
HS9026	Current Procedure Step	X							X
HS9027	Completed Procedure Steps	X							X
HS9028	Crew Notification of Required Procedure Action	X							X
HS9029	Annunciation Hierarchy	X							X
HS9029A	Annunciation Prioritization	X							X
HS9030	Visual and Auditory Annunciation	X							X
HS9032	Distinctiveness of Annunciations	X							X
HS9032A	Loss of Annunciation Capability	X						X	
HS9037	Decomposition of Chemicals	X				X	X		X

Revision: E	Document No: CxP 70024
Release Date: 11/19/10	Page: 433 of 503
Title: Constellation Program Human-Systems Integration Requirements	

REQUIREMENTS								VERIFICATIONS	
Requirement	Requirement Name	Orion	Ares I	MS	GO	EVA	FCE	LEVEL II	LEVEL III
HS9040	Data Fidelity	X							X
HS9042A	Manual Information Capture and Transfer								
HS10001	Maintainability Without Deintegration	X	X						X
HS10002	Work Envelope Volumes	X	X						X
HS10004	Reach Envelope Volumes	X	X						X
HS10006	Ground Crew Visual Access	X	X						X
HS10008	Ground Anthropometry, Biomechanics, and Strength	X	X					X	
HS10009	Maintainability Without Disabling Subsystems	X	X						
HS10010	Fuse/Circuit Indication	X	X						X
HS10011	Appropriate Clothing and Equipment	X	X						X
HS10012	LRU Installation	X	X						X
HS10013	LRU Mounting/Alignment Labels/Codes	X	X						X
HS10014	LRU Interchangeability	X	X						X
HS10015	Connector Mismatching	X	X						X
HS10017	Connector Mating Labels	X	X						X
HS10019	Maintenance Without Damage	X	X						X
HS10020	Fluid Management	X	X						X
HS10021	Fluid Spillage Control	X	X						X
HS10022	System Safing Controls	X	X						X
HS10023	Equipment Protection	X	X			X			
HS10024	Tool Clearances	X	X						X
HS10025	Inspection Access	X	X						X
HS10026	Captive Fasteners	X	X						
HS10027	Ventilation Openings	X	X						X
HS10028	Toolset	X	X						X
HS10029	Safety Displays	X	X						X
HS10030	Ground Processing Hardware Access	X	X						X
HS10031	LRU Tracking Labels	X	X						X
HS10032	LRU Labeling	X	X						X
HS10033	Hazards Labeling	X	X			X	X		X
HS10039	Labeling	X	X						X
HS10042	LRU Protrusions	X	X						X
HS10043	Protrusion Label/Support	X	X						X
HS10045	LRU Weight Limit	X	X						X
HS10047	Work Station Layout Interference	X	X						
HS10048	Work Station Layout Sequential Operations	X	X						
HS10050	Consistent Crew Interfaces	X	X						
HS10051	Legibility	X	X						X
HS10052	Written Text	X	X						X
HS10053	Use of Color	X	X						

Revision: E	Document No: CxP 70024
Release Date: 11/19/10	Page: 434 of 503
Title: Constellation Program Human-Systems Integration Requirements	

REQUIREMENTS								VERIFICATIONS	
Requirement	Requirement Name	Orion	Ares I	MS	GO	EVA	FCE	LEVEL II	LEVEL III
HS10054	LRU Removal Without Component Removal	X	X						
HS10055	Ground Labeling: Non-Interference with Flight Labels	X				X	X		X

Revision: E	Document No: CxP 70024
Release Date: 11/19/10	Page: 436 of 503
Title: Constellation Program Human-Systems Integration Requirements	

APPENDIX J – Block 1 (Fully Functional ISS) DRM ALLOCATION MATRIX

This table denotes allocation of HSIR requirements to the various systems. An "X" in the column of any system for a given requirement allocates the requirement to that system. The system is either required to meet the requirement independently or in conjunction with other systems to which that requirement is allocated. Additionally, the last two columns denote which Verification Requirements must be satisfied with the verification requirements contained within the HSIR, Section 4.0 (those marked LII), OR which may be verified using alternate acceptable methods that have been Level III Project approved and documented (those marked LIII). The Level III projects are not required to obtain approval for verification closure or changes to verification methodology beyond their own project boards when verification has been designated Level III. Designation of Level II verification denotes that the Level II Program dictates and maintains change authority over the verification methodology but does not necessarily imply that Level II performs the verification.

The Fully Functional International Space Station (FFISS) Design Reference Mission (DRM) supports ISS increment crew rotation and resupply of the ISS. ISS missions provide a proving ground for Constellations systems while at the same time providing an alternate resource for the support of ISS crewed operations. The mission duration includes 7 days of active Orion operations, and 210 days docked to ISS. The requirements applicable to the FFISS DMR can be found in Table J-3 – Allocation Matrix for FFISS DRM. Note that Table J-3 is only applicable for the Fully Functional ISS DRM.

TABLE J-3 - ALLOCATION MATRIX FOR FFISS DRM

REQUIREMENTS								VERIFICATIONS	
Requirement	Requirement Name	Orion	Ares I	MS	GO	EVA	FCE	LEVEL II	LEVEL III
HS2001	Anthropometric Dimensions for Unsuiting Crewmembers	X				X	X		X
HS2002	Anthropometric Dimensions for Suited Crewmembers	X			X	X	X		X
HS2003	Range of Motion of an Unsuiting Crewmember	X				X	X		X
HS2004	Range of Motion of a Suited Crewmember	X			X	X	X		X
HS2005	Mass Properties of an Unsuiting Crewmember	X				X	X		
HS2006	Mass Properties of a Suited Crewmember	X			X	X	X		X
HS2007	Structural Integrity of Hardware for an Unsuiting Crewmember	X				X	X		X
HS2007B	Structural Integrity of Hardware for a Suited Crewmember	X			X	X	X		
HS2008	Minimum Crew Operational Loads for	X				X	X		X

Revision: E	Document No: CxP 70024
Release Date: 11/19/10	Page: 437 of 503
Title: Constellation Program Human-Systems Integration Requirements	

REQUIREMENTS								VERIFICATIONS	
Requirement	Requirement Name	Orion	Ares I	MS	GO	EVA	FCE	LEVEL II	LEVEL III
	an Unsited Crewmember								
HS2008B	Minimum Crew Operational Loads for a Suited Crewmember	X			X	X	X		
HS2009	Equipment Damage Hazard	X				X	X		X
HS2010	Total Crew Control Mass	X							X
HS3001	O2 and Total Pressure Control	X		X				X	
HS3004	Total Pressure for Nominal Vehicle Operations	X							X
HS3004B	O2 Partial Pressure for Nominal Vehicle Operations	X							X
HS3004C	CO2 Partial Pressure for Nominal Vehicle Operations	X				X			X
HS3004D	N2 Partial Pressure for Nominal Vehicle Operations								
HS3005	Total Pressure Tolerance Ranges for Crew Exposure	X				X			X
HS3005B	O2 Partial Pressure Tolerance Ranges for Crew Exposure	X				X			X
HS3005C	CO2 Partial Pressure Tolerance Ranges for Crew Exposure	X				X			X
HS3006	Microbial Air Contamination	X							X
HS3006C	Particulate Contamination	X				X			X
HS3006D	Lunar Dust Contamination								
HS3007	Gaseous Pollutants Limits	X				X	X		X
HS3009	Rate of Change of Pressure Limits	X				X			X
HS3012A	Combustion Products Monitoring	X							X
HS3012B	Combustion Products Measurement	X							X
HS3012D	Carbon Monoxide Alert	X							X
HS3013	Composition Reporting	X							X
HS3014	Composition Alerting	X							X
HS3015	Toxic Hazard Level 3	X				X	X		X
HS3015A	Toxic Hazard Level 4	X	X			X	X		X
HS3016	Personal Protective Equipment						X		X
HS3017	Crew Communication During Contingency Breathing	X					X		X
HS3017A	Contingency Breathing Apparatus						X		X
HS3017B	Mission Systems Communication During Contingency Breathing	X		X			X		X

Revision: E	Document No: CxP 70024
Release Date: 11/19/10	Page: 438 of 503
Title: Constellation Program Human-Systems Integration Requirements	

REQUIREMENTS								VERIFICATIONS	
Requirement	Requirement Name	Orion	Ares I	MS	GO	EVA	FCE	LEVEL II	LEVEL III
HS3019	Physiochemical Limits for Potable Water	X			X	X	X	X	
HS3019A	Microbial Limits for Potable Water	X			X	X	X		X
HS3025	Potable Water for On-Orbit Drinking	X							X
HS3026	Potable Water for Fluid Loading	X							X
HS3027	Potable Water for Post-Landing	X					X		X
HS3028	Potable Water for Personal Hygiene	X					X		X
HS3029	Potable Water Rate	X							X
HS3030	Potable Water Temperature for Cold Drinks	X					X		
HS3031	Potable Water Temperature for Hot Food and Drinks	X							X
HS3032	Potable Water Temperature for Personal Hygiene	X							
HS3034	Water Sampling	X			X				X
HS3036	Nominal Atmospheric Temperature	X							X
HS3037	Contingency Control of Heat Stored by Crewmembers	X				X		X	
HS3046	Relative Humidity for Nominal Vehicle	X							X
HS3047	In-flight Ventilation	X							X
HS3050	Supplemental Ventilation	X							X
HS3051	Temperature Set-Point Adjustment	X							X
HS3052	Temperature Set-Point Accessibility	X							X
HS3053	Temperature Set-Point Increments	X							X
HS3054	Temperature Set-Point Error	X							X
HS3055	Display and Monitoring of Temperature and Relative Humidity	X							X
HS3059	Crew Exposure to Rate of Change of Acceleration	X	X		X				X
HS3060	Linear Acceleration Limits during Nominal Return	X							X
HS3061	Linear Acceleration Limits from Launch to Mission Destination	X	X					X	
HS3062	Linear Acceleration Limits for Ascent Abort and Off-Nominal	X	X					X	
HS3064	Crew Injury Risk Limits	X				X		X	
HS3065	Sustained Rotational Acceleration Limit	X	X					X	
HS3069	Rotational Limits for Nominal Return	X							X

Revision: E	Document No: CxP 70024
Release Date: 11/19/10	Page: 439 of 503
Title: Constellation Program Human-Systems Integration Requirements	

REQUIREMENTS								VERIFICATIONS	
Requirement	Requirement Name	Orion	Ares I	MS	GO	EVA	FCE	LEVEL II	LEVEL III
HS3070	Rotational Limits for Launch to Mission Destination	X	X					X	
HS3071	Rotational Limits for Ascent Abort and Off-Nominal Entry	X	X					X	
HS3072	Hazardous Noise Limit for Launch and Entry	X	X			X		X	
HS3073	Noise Dose Limits for Launch and Entry	X	X			X		X	
HS3074	Impulse Noise Limit for Launch and Entry	X	X			X		X	
HS3075	Hazardous Noise Limit for the Orbit Phase	X				X	X		X
HS3076	Sound Pressure Level (SPL) Limits for Continuous Noise during Orbit Phase	X				X	X	X	
HS3078	Impulse Noise Limit for the Orbit Phase	X				X	X		X
HS3079	Annoyance Noise Limits for Crew Sleep	X					X		X
HS3080	Tonal and Narrow-Band Noise Limits	X				X	X	X	
HS3081	Infrasonic Noise Limits	X	X					X	
HS3082	Cabin Depressurization Valve Hazardous Noise Limit	X				X		X	
HS3083	Cabin Depressurization Valve Noise Dose Limits	X				X		X	
HS3084	Reverberation Time	X							X
HS3085	Radiation Design Requirements	X						X	
HS3086	Charged Particle Monitoring								
HS3088	Dose Equivalent Monitoring								
HS3089	Absorbed Dose Monitoring								
HS3090	Passive Radiation Monitoring	X					X		X
HS3091	Radiation Data Reporting to the Crew - Absorbed Dose								
HS3092	Alerting for Radiation Data								
HS3093	Radio-Frequency Electromagnetic Field Radiation Limits	X	X		X		X	X	
HS3094	Ocular Exposure to Lasers	X	X		X		X	X	
HS3096	Dermal Exposure to Lasers	X	X		X		X	X	
HS3098	Retinal Thermal Injury from Visible and Near Infrared Sources	X			X		X	X	
HS3099	Small Source Visible Radiation Limits	X			X		X	X	
HS3101	Large Source Visible Radiation Limits	X			X		X	X	

Revision: E	Document No: CxP 70024
Release Date: 11/19/10	Page: 440 of 503
Title: Constellation Program Human-Systems Integration Requirements	

REQUIREMENTS								VERIFICATIONS	
Requirement	Requirement Name	Orion	Ares I	MS	GO	EVA	FCE	LEVEL II	LEVEL III
HS3103	Thermal Injury from Infrared Radiation	X			X		X	X	
HS3104	Ultraviolet Exposure for Unprotected Eye or Skin	X			X		X	X	
HS3105	Health Limits for Vibration During Dynamic Phases of Flight	X	X			X		X	
HS3106	Vibration Limits during Crew Sleep	X						X	
HS3108	Pre-Launch Vibration Limit to Prevent Motion Sickness	X	X		X			X	
HS3109	Sound Pressure Level (SPL) Limits for Intermittent Noise Duration	X					X		X
HS3110	Noise Limit for Personal Communication Devices	X				X	X	X	
HS3111	Loudspeaker Alarm Audibility	X						X	
HS3112	Radiation Data Reporting to Mission Systems - Absorbed Dose								
HS3113	Particle Archive Data								
HS3114	Ventilation Adjustment	X							X
HS3115	Display of Actual Temperature	X							X
HS3116	Display of Temperature Set-Point	X							X
HS3117	Potable Water Dispensing	X							X
HS3118	Potable Hot Water Quantity for Rehydration	X							X
HS3119	Radiation Data Reporting to the Crew - Dose Equivalent								
HS3120	Radiation Data Reporting to Mission Systems - Dose								
HS3121	Potable Water Temperature for Medical Use						X		X
HS3122	Potable Water for Medical Use	X							X
HS3123	Potable Water for Medical Contingency	X							X
HS3124	Head Protection Criteria	X				X			
HS3125	Neck Protection Criteria	X				X			
HS3126	Relative Humidity Tolerance Ranges for Crew Exposure	X				X			X
HS3127	Potable Water for On-Orbit Food Rehydration	X							X
HS3128	Transient Force	X				X			

Revision: E	Document No: CxP 70024
Release Date: 11/19/10	Page: 441 of 503
Title: Constellation Program Human-Systems Integration Requirements	

REQUIREMENTS								VERIFICATIONS	
Requirement	Requirement Name	Orion	Ares I	MS	GO	EVA	FCE	LEVEL II	LEVEL III
	Application Limits								
HS3129	Chest Deflection	X				X			
HS3130	Restrained Body Movement	X				X		X	
HS3132	Head Transient Acceleration Limits	X				X			
HS3133	Sound Pressure Level (SPL) Limits for Waste Management System	X							X
HS3134	Speech Interference Level Limit for Pre-Launch and Post-Landing	X				X			X
HS4002	Corners and Edges Exposed during Nominal Operations	X			X	X	X		X
HS4003	Corners and Edges Exposed during Maintenance	X				X	X		X
HS4004	Corners and Edges of Loose Equipment	X				X	X		X
HS4005	Burrs	X			X	X	X		X
HS4006	Sharp Items	X			X	X	X		X
HS4007	Interior Item Restraints	X				X	X		X
HS4008	Electrical Hazard Potential	X				X	X		X
HS4008B	Chassis Leakage Current - Nonpatient Equipment	X				X	X		X
HS4008C	Chassis Leakage Current - Patient Equipment	X				X	X		X
HS4012	Hot Touch Temperature Limit	X				X	X		X
HS4012A	Cold Touch Temperature Limit	X				X	X		X
HS4019	Fire Suppression Portability	X					X		X
HS4021	Pinch Points	X			X	X	X		X
HS4022	Emergency Equipment Access	X			X	X	X		X
HS4023	Holes	X			X	X	X		X
HS5001	Layout Interference	X							
HS5002	Layout Sequential Operations	X							
HS5003	Workstation Orientation	X							X
HS5004	Ingress and Egress Translation Paths	X						X	
HS5005	Internal Translation Paths	X							X
HS5006	Standard Restraints and Mobility Aids	X					X		
HS5007	IVA Mobility Aids	X					X		X
HS5008	Workstation Restraints	X							X
HS5009	Ingress and Egress Mobility Aids	X			X			X	
HS5010	Crew Egress Translation Path - Ground	X			X				X
HS5012	Flail Injury Protection	X				X		X	

Revision: E	Document No: CxP 70024
Release Date: 11/19/10	Page: 442 of 503
Title: Constellation Program Human-Systems Integration Requirements	

REQUIREMENTS								VERIFICATIONS	
Requirement	Requirement Name	Orion	Ares I	MS	GO	EVA	FCE	LEVEL II	LEVEL III
HS5013	Hatches Operable Inside and Outside	X			X				X
HS5014	Hatch Manual Pressure Equalization Inside and Outside	X							X
HS5016	Hatch Closure Indication	X							X
HS5017	Hatch Visual Observation	X							X
HS5019	Window Optical Properties	X							X
HS5021	Window Viewing for Piloting Tasks	X							X
HS5022	Window for External Viewing Observation	X							X
HS5027	Window Cover, Shade, and Filter Removal or Replacement in 10 Seconds	X							X
HS5030	Obstruction	X							
HS5031	Window and Internal Darkening	X							X
HS5032	Window Proximity Finishes	X							X
HS5034B	Interior Light Adjustability	X							X
HS5035	Lighting Level by Task	X					X		X
HS5039	General Light Control	X							X
HS5040	Workstation Light Control	X							X
HS5041	Workstation Light Position Adjustment	X							X
HS5042	Workstation Visual Demarcations	X							X
HS5043	Hatches Operable in 60 Seconds	X			X				X
HS5044	Hatches Operable Without Tools	X			X				X
HS5045	Hatches Operable by Suited Crewmembers	X							X
HS5046	Unlatching Hatches	X							X
HS5048	Hatch Manual Pressure Equalization by Suited Crewmembers	X							X
HS5049	Hatch Latch Position	X							X
HS5050	Hatch Pressure Difference Measurement	X							X
HS5051	Window Cover, Shade, and Filter Removal or Replacement Without Tools	X							X
HS5052	Commonly Distinguishable Handrails	X							
HS5053	Crew Ingress/Egress Translation Path in Space	X						X	
HS5054	Egress Handrails	X			X				
HS5055	Window for Motion Imagery and	X							X

Revision: E	Document No: CxP 70024
Release Date: 11/19/10	Page: 443 of 503
Title: Constellation Program Human-Systems Integration Requirements	

REQUIREMENTS								VERIFICATIONS	
Requirement	Requirement Name	Orion	Ares I	MS	GO	EVA	FCE	LEVEL II	LEVEL III
	Photography								
HS5056	Lighting ON/OFF Control	X							X
HS6001	Cross-Contamination Prevention	X							
HS6002	Cross-Contamination Separation	X							
HS6003	Heating	X					X		X
HS6004	Rehydration	X					X		X
HS6005	In-Flight Food Preparation Time	X					X		
HS6009	Personal Hygiene Privacy	X							X
HS6010	Personal Hygiene Stowage	X							
HS6012	Personal Hygiene Trash	X							
HS6013	Vomitus Collection and Containment	X					X		X
HS6014	Simultaneous Defecation and Urination	X				X			X
HS6016	Fecal Wipes	X				X			X
HS6017	Feces per Day	X				X			X
HS6020	Diarrhea per Event	X							X
HS6020C	Feces per Event	X							X
HS6020D	Diarrheal Events per Crewmember	X							X
HS6021	Urine Collection	X							X
HS6022	Urine Wipes	X							X
HS6023	Urine per Crewmember	X							X
HS6024	Urine per Hour	X							X
HS6025	Urine Rate	X							X
HS6025B	Urine per Day	X							X
HS6027	Full Body Visual Privacy	X							X
HS6028	Body Self-Inspection and Cleaning	X							
HS6029	Waste Management Odor Control	X					X		X
HS6030	Waste Management Stowage	X					X		X
HS6031	Waste Management Trash	X					X		
HS6032	Exercise Capability								
HS6035	Exercise Operational Envelope								
HS6036	Thermal Environment During Exercise								
HS6037	Carbon Dioxide Levels During Exercise								
HS6038	Relative Humidity During Exercise								
HS6044	Stowage Nominal Operation	X							
HS6046	Stowage Location	X							
HS6047	Stowage Arrangement	X					X		
HS6049	Stowage Reconfiguration	X							

Revision: E	Document No: CxP 70024
Release Date: 11/19/10	Page: 444 of 503
Title: Constellation Program Human-Systems Integration Requirements	

REQUIREMENTS								VERIFICATIONS	
Requirement	Requirement Name	Orion	Ares I	MS	GO	EVA	FCE	LEVEL II	LEVEL III
HS6050	Stowage Restraints	X					X		X
HS6051	Stowage Hand Operation	X					X		X
HS6052	Stowage Commonality	X					X		
HS6053	Stowage Compatibility with Inventory Management					X	X		X
HS6054	Trash Management Nominal Operations	X							
HS6056	Trash Management Odor Control	X					X		X
HS6057	Trash Management Contamination Control	X					X		X
HS6058	Trash Management Hazard Containment	X					X		X
HS6059	Food System						X	X	
HS6060	Metabolic Intake						X	X	
HS6062	Metabolic Intake for EVA						X	X	
HS6063	Potable Water for EVA Operations								
HS6069	Auditory and Olfactory Privacy	X							
HS6073	Oxygen Levels During Exercise								
HS6075	Private Voice	X		X	X				X
HS6076	Private Video	X		X					X
HS6077	Biomedical Data						X		X
HS6078	Biomedical Relay	X						X	
HS6079	Biomedical Display	X						X	
HS6081	DCS Over-Pressurization	X				X		X	
HS6082	Orthostatic Protection	X				X			X
HS6083	Medical Care Provider Access	X							X
HS6084	Patient Electrical Isolation	X							X
HS6085	Access to Medical Equipment	X							X
HS6086	Access to Deployed Medical Kits	X							X
HS6091	Denitrogenation	X				X		X	
HS6097	Communication Capabilities								X
HS6099	Personalized In-Flight Updates						X	X	
HS6100	DCS Event Pressure	X				X		X	
HS6101	Medical Care Capabilities	X				X	X	X	
HS6102	Lunar Surface Food Preparation Time								
HS6104	Crew Sleep Accommodations	X					X		X
HS6105	Personal Hygiene Items						X		X
HS6106	Stowage Equipment Cover Restraint	X					X		X
HS7003	Handling Qualities for Manual Control – Level 1	X						X	

Revision: E	Document No: CxP 70024
Release Date: 11/19/10	Page: 445 of 503
Title: Constellation Program Human-Systems Integration Requirements	

REQUIREMENTS								VERIFICATIONS	
Requirement	Requirement Name	Orion	Ares I	MS	GO	EVA	FCE	LEVEL II	LEVEL III
HS7004	Handling Qualities for Manual Control – Level 2	X						X	
HS7007	Consistent Crew Interfaces	X				X			
HS7009	Location Coding	X							X
HS7010	Field of View	X				X			X
HS7010A	Two-Crew Operations	X							X
HS7018	Viewing Critical Displays and Controls	X			X				
HS7018A	Viewing Frequently Used Displays and Controls	X							
HS7019	Functional Reach Envelope	X			X				X
HS7021	Reach for Critical Controls	X							
HS7021A	Reach for Frequently Used Controls	X							
HS7022	Functional Related Displays and Controls	X							
HS7023	Successive Operation of Displays and Controls	X							
HS7024	Control Spacing For Suited Operations	X				X			X
HS7027	Over 3 g	X							X
HS7028	Over 2 g	X							X
HS7029	Supports	X							X
HS7036	Labeling	X				X	X	X	
HS7044	Legibility	X				X	X		X
HS7049	Notifications	X							X
HS7049A	Manual Silencing	X							X
HS7055	Command Feedback	X							X
HS7058	Subsystem State Information	X							X
HS7058A	System Responsiveness for Discrete Inputs	X							X
HS7058B	System Responsiveness for Continuous Inputs	X							
HS7058C	Request for Information	X							
HS7058D	Request for Critical Information	X							X
HS7058E	Menu Update Time	X							X
HS7059	Task-Oriented Displays	X							X
HS7060	Subsystem-Oriented Displays	X							X
HS7060A	Viewing Simultaneous Task Information	X							
HS7061	Location within the Display Hierarchy	X							X
HS7063	Compatibility of Movement	X				X			X
HS7063A	Control Feedback	X				X			X
HS7063B	Protection against Inadvertent Activation	X				X			
HS7063C	Protection for Flight	X				X			X

Revision: E	Document No: CxP 70024
Release Date: 11/19/10	Page: 446 of 503
Title: Constellation Program Human-Systems Integration Requirements	

REQUIREMENTS								VERIFICATIONS	
Requirement	Requirement Name	Orion	Ares I	MS	GO	EVA	FCE	LEVEL II	LEVEL III
	Actuated Critical Controls								
HS7063D	Coding for Emergency Controls	X				X			X
HS7063E	Restraints for Control Operation	X							X
HS7064	Language	X			X	X	X		X
HS7065A	Use of Color	X				X	X		X
HS7066	Crew Interface Usability	X				X		X	
HS7067	Obscured Controls	X				X			X
HS7070	Viewing Simultaneous Critical Task Information	X							X
HS7071	Access within the Display Hierarchy	X							
HS7072	State Change	X						X	
HS7072A	Lost Data	X							X
HS7075	Volume Control for Auditory Annunciations	X							X
HS7076	Speech Intelligibility	X		X	X	X			X
HS7077	Volume Control for Audio Communications	X							X
HS7079	Nomenclature	X				X	X	X	
HS7080	Workload Measure: Nominal	X				X		X	
HS7080A	Workload Measure: Off-Nominal	X				X		X	
HS7082	Self-Illuminated Controls and Displays	X							X
HS7083	Protection for Ground Actuated Critical Controls			X	X				X
HS7925	Control Spacing for Unsited Operations	X							X
HS8001	ORU Change-out	X					X		X
HS8002	Maintenance Time per Day	X							X
HS8003	ORU Maintenance Time	X							X
HS8003-Objective	ORU Replacement Time/Maintenance	X							
HS8004	LRU Removal and Replacement	X	X						
HS8005	Physical Features	X				X	X		X
HS8006	Labeling and Marking	X				X	X		X
HS8007	Interchangeability	X							X
HS8008	Connectors	X				X	X		X
HS8009	Visual Access	X				X			X
HS8010	Physical Access	X							X
HS8011	Cable Access	X	X						X
HS8013	External Service Points								
HS8015	Maintenance Hazard	X				X	X		X
HS8016	Failure Notification	X							X
HS8017	No Fuses for Dynamic Flight Phases	X							X
HS8018	Circuit Breakers Instead of Fuses	X							

Revision: E	Document No: CxP 70024
Release Date: 11/19/10	Page: 447 of 503
Title: Constellation Program Human-Systems Integration Requirements	

REQUIREMENTS								VERIFICATIONS	
Requirement	Requirement Name	Orion	Ares I	MS	GO	EVA	FCE	LEVEL II	LEVEL III
HS8020	Replacement Without Tools	X							X
HS8021	Replacement Without Component Removal	X							X
HS8022	Circuit Breaker Resetting	X							X
HS8023	Trip Indication	X							X
HS8024	Electrostatic Discharge	X					X		X
HS8026	Access Points	X				X			
HS8029	Fastener Heads	X				X	X		X
HS8030	Fastener Number and Variety	X				X	X		
HS8031	Captive Fasteners	X				X	X		X
HS8032	Equipment Isolation	X							X
HS8034	Hazardous Levels of Fluid Leakage	X							X
HS8037	Common Toolset	X				X	X		
HS8041	Microbial Contamination	X				X	X		X
HS8042	Fungal Contamination	X				X	X		X
HS8043	Replacement of Air Filters	X							
HS8045	Visual Indication	X				X	X		X
HS8046	Connector Mating Indication	X				X	X		X
HS8047	Unique Identification Labeling	X				X	X	X	
HS8048	Visual Line of Sight	X	X						
HS8051	Condensation Prevention on Interior Surfaces	X							X
HS8052	Tool Clearance	X				X	X		X
HS8053	Disturbance of Equipment	X							
HS8054	Tool Usage	X				X	X		X
HS8055	Crew Control of Power	X							X
HS9014	Data Rate	X							
HS9018	Locations of Data	X					X		X
HS9019	Wired Network	X							X
HS9020	Wireless Network								X
HS9021	Crew Operability	X							X
HS9025	Displaying Electronic Procedures System	X							X
HS9025A	Cueing Electronic Procedures System	X							X
HS9026	Current Procedure Step	X							X
HS9027	Completed Procedure Steps	X							X
HS9028	Crew Notification of Required Procedure Action	X							X
HS9029	Annunciation Hierarchy	X							X
HS9029A	Annunciation Prioritization	X							X
HS9030	Visual and Auditory Annunciation	X							X
HS9032	Distinctiveness of Annunciations	X							X

Revision: E	Document No: CxP 70024
Release Date: 11/19/10	Page: 448 of 503
Title: Constellation Program Human-Systems Integration Requirements	

REQUIREMENTS								VERIFICATIONS	
Requirement	Requirement Name	Orion	Ares I	MS	GO	EVA	FCE	LEVEL II	LEVEL III
HS9032A	Loss of Annunciation Capability	X						X	
HS9037	Decomposition of Chemicals	X				X	X		X
HS9040	Data Fidelity	X							X
HS9042A	Manual Information Capture and Transfer						X		X
HS10001	Maintainability Without Deintegration	X	X						X
HS10002	Work Envelope Volumes	X	X						X
HS10004	Reach Envelope Volumes	X	X						X
HS10006	Ground Crew Visual Access	X	X						X
HS10008	Ground Anthropometry, Biomechanics, and Strength	X	X					X	
HS10009	Maintainability Without Disabling Subsystems	X	X						
HS10010	Fuse/Circuit Indication	X	X						X
HS10011	Appropriate Clothing and Equipment	X	X						X
HS10012	LRU Installation	X	X						X
HS10013	LRU Mounting/Alignment Labels/Codes	X	X						X
HS10014	LRU Interchangeability	X	X						X
HS10015	Connector Mismatching	X	X						X
HS10017	Connector Mating Labels	X	X						X
HS10019	Maintenance Without Damage	X	X						X
HS10020	Fluid Management	X	X						X
HS10021	Fluid Spillage Control	X	X						X
HS10022	System Safing Controls	X	X						X
HS10023	Equipment Protection	X	X			X			
HS10024	Tool Clearances	X	X						X
HS10025	Inspection Access	X	X						X
HS10026	Captive Fasteners	X	X						
HS10027	Ventilation Openings	X	X						X
HS10028	Toolset	X	X						X
HS10029	Safety Displays	X	X						X
HS10030	Ground Processing Hardware Access	X	X						X
HS10031	LRU Tracking Labels	X	X						X
HS10032	LRU Labeling	X	X						X
HS10033	Hazards Labeling	X	X			X	X		X
HS10039	Labeling	X	X						X
HS10042	LRU Protrusions	X	X						X
HS10043	Protrusion Label/Support	X	X						X
HS10045	LRU Weight Limit	X	X						X
HS10047	Work Station Layout Interference	X	X						
HS10048	Work Station Layout Sequential Operations	X	X						
HS10050	Consistent Crew	X	X						

Revision: E	Document No: CxP 70024
Release Date: 11/19/10	Page: 449 of 503
Title: Constellation Program Human-Systems Integration Requirements	

REQUIREMENTS								VERIFICATIONS	
Requirement	Requirement Name	Orion	Ares I	MS	GO	EVA	FCE	LEVEL II	LEVEL III
	Interfaces								
HS10051	Legibility	X	X						X
HS10052	Written Text	X	X						X
HS10053	Use of Color	X	X						
HS10054	LRU Removal Without Component Removal	X	X						
HS10055	Ground Labeling: Non-Interference with Flight Labels	X				X	X		X

Revision: E	Document No: CxP 70024
Release Date: 11/19/10	Page: 451 of 503
Title: Constellation Program Human-Systems Integration Requirements	

APPENDIX J – Block 2 (Exo-LEO/Lunar) DRM ALLOCATION MATRIX

This table denotes allocation of HSIR requirements to the various systems. An "X" in the column of any system for a given requirement allocates the requirement to that system. The system is either required to meet the requirement independently or in conjunction with other systems to which that requirement is allocated. Additionally, the last two columns denote which Verification Requirements must be satisfied with the verification requirements contained within the HSIR, Section 4.0 (those marked LII), OR which may be verified using alternate acceptable methods that have been Level III Project approved and documented (those marked LIII). The Level III projects are not required to obtain approval for verification closure or changes to verification methodology beyond their own project boards when verification has been designated Level III. Designation of Level II verification denotes that the Level II Program dictates and maintains change authority over the verification methodology but does not necessarily imply that Level II performs the verification.

The Block 2 (Exo-LEO/Lunar) DRM includes 21 days of active operations, and as many as 210 days uncrewed operations. The requirements applicable to the Exo-LEO/Lunar DRM can be found in Table J-4 – Allocation Matrix for Lunar DRM. Note that Table J-4 is only applicable for the Exo-LEO/Lunar DRM.

TABLE J-4 - ALLOCATION MATRIX FOR EXO-LEO/LUNAR DRM

Requirement	Requirement Name	REQUIREMENTS								VERIFICATIONS	
		Orion	Altair	Ares I	Ares V	MS	GO	EVA	FCE	LEVEL II	LEVEL III
HS2001	Anthropometric Dimensions for Unsuiting Crewmembers	X	X					X	X		X
HS2002	Anthropometric Dimensions for Suited Crewmembers	X	X				X	X	X		X
HS2003	Range of Motion of an Unsuiting Crewmember	X	X					X	X		X
HS2004	Range of Motion of a Suited Crewmember	X	X				X	X	X		X
HS2005	Mass Properties of an Unsuiting Crewmember	X	X					X	X		
HS2006	Mass Properties of a Suited Crewmember	X	X				X	X	X		X
HS2007	Structural Integrity of Hardware for an Unsuiting Crewmember	X	X					X	X		X

Revision: E	Document No: CxP 70024
Release Date: 11/19/10	Page: 452 of 503
Title: Constellation Program Human-Systems Integration Requirements	

Requirement	Requirement Name	REQUIREMENTS								VERIFICATIONS	
		Orion	Altair	Ares I	Ares V	MS	GO	EVA	FCE	LEVEL II	LEVEL III
HS2007B	Structural Integrity of Hardware for a Suited Crewmember	X	X				X	X	X		
HS2008	Minimum Crew Operational Loads for an Unsuited Crewmember	X	X					X	X		X
HS2008B	Minimum Crew Operational Loads for a Suited Crewmember	X	X				X	X	X		
HS2009	Equipment Damage Hazard	X	X					X	X		X
HS2010	Total Crew Control Mass	X	X								X
HS3001	O2 and Total Pressure Control	X	X			X				X	
HS3004	Total Pressure for Nominal Vehicle Operations	X	X								X
HS3004B	O2 Partial Pressure for Nominal Vehicle Operations	X	X					X			X
HS3004C	CO2 Partial Pressure for Nominal Vehicle Operations	X	X					X			X
HS3004D	N2 Partial Pressure for Nominal Vehicle Operations	X	X								X
HS3005	Total Pressure Tolerance Ranges for Crew Exposure	X	X					X			X
HS3005B	O2 Partial Pressure Tolerance Ranges for Crew Exposure	X	X					X			X
HS3005C	CO2 Partial Pressure Tolerance Ranges for Crew Exposure	X	X					X			X
HS3006	Microbial Air Contamination	X	X								X
HS3006C	Particulate Contamination	X	X					X			X
HS3006D	Lunar Dust Contamination	X	X					X	X		X
HS3007	Gaseous	X	X					X	X		X

Revision: E	Document No: CxP 70024
Release Date: 11/19/10	Page: 454 of 503
Title: Constellation Program Human-Systems Integration Requirements	

Requirement	Requirement Name	REQUIREMENTS								VERIFICATIONS	
		Orion	Altair	Ares I	Ares V	MS	GO	EVA	FCE	LEVEL II	LEVEL III
	Temperature for Hot Food and Drinks										
HS3032	Potable Water Temperature for Personal Hygiene	X	X								
HS3034	Water Sampling	X	X				X				X
HS3036	Nominal Atmospheric Temperature	X	X								X
HS3037	Contingency Control of Heat Stored by Crewmembers	X	X					X		X	
HS3046	Relative Humidity for Nominal Vehicle	X	X					X			X
HS3047	In-flight Ventilation	X	X								X
HS3050	Supplemental Ventilation	X	X								X
HS3051	Temperature Set-Point Adjustment	X	X								X
HS3052	Temperature Set-Point Accessibility	X	X								X
HS3053	Temperature Set-Point Increments	X	X								X
HS3054	Temperature Set-Point Error	X	X								X
HS3055	Display and Monitoring of Temperature and Relative Humidity	X	X								X
HS3059	Crew Exposure to Rate of Change of Acceleration	X	X	X	X		X				X
HS3060	Linear Acceleration Limits during Nominal Return	X									X
HS3061	Linear Acceleration Limits from Launch to Mission Destination	X	X	X	X					X	
HS3062	Linear Acceleration Limits for Ascent Abort and Off-Nominal	X	X	X	X					X	
HS3064	Crew Injury Risk Limits	X						X		X	

Revision: E	Document No: CxP 70024
Release Date: 11/19/10	Page: 456 of 503
Title: Constellation Program Human-Systems Integration Requirements	

Requirement	Requirement Name	REQUIREMENTS								VERIFICATIONS	
		Orion	Altair	Ares I	Ares V	MS	GO	EVA	FCE	LEVEL II	LEVEL III
HS3086	Charged Particle Monitoring								X	X	
HS3088	Dose Equivalent Monitoring								X	X	
HS3089	Absorbed Dose Monitoring								X	X	
HS3090	Passive Radiation Monitoring	X	X						X		X
HS3091	Radiation Data Reporting to the Crew - Absorbed Dose	X	X					X			X
HS3092	Alerting for Radiation Data	X	X					X			X
HS3093	Radio-Frequency Electromagnetic Field Radiation Limits	X	X	X	X		X	X	X	X	
HS3094	Ocular Exposure to Lasers	X	X	X	X		X		X	X	
HS3096	Dermal Exposure to Lasers	X	X	X	X		X		X	X	
HS3098	Retinal Thermal Injury from Visible and Near Infrared Sources	X	X				X	X	X	X	
HS3099	Small Source Visible Radiation Limits	X	X				X	X	X	X	
HS3101	Large Source Visible Radiation Limits	X	X				X	X	X	X	
HS3103	Thermal Injury from Infrared Radiation	X	X				X	X	X	X	
HS3104	Ultraviolet Exposure for Unprotected Eye or Skin	X	X				X	X	X	X	
HS3105	Health Limits for Vibration During Dynamic Phases of Flight	X	X	X	X			X		X	
HS3106	Vibration Limits during Crew Sleep	X	X		X					X	
HS3108	Pre-Launch Vibration Limit to Prevent Motion Sickness	X		X			X			X	

Revision: E	Document No: CxP 70024
Release Date: 11/19/10	Page: 458 of 503
Title: Constellation Program Human-Systems Integration Requirements	

Requirement	Requirement Name	REQUIREMENTS								VERIFICATIONS	
		Orion	Altair	Ares I	Ares V	MS	GO	EVA	FCE	LEVEL II	LEVEL III
HS3128	Transient Force Application Limits	X						X			
HS3129	Chest Deflection	X						X			
HS3130	Restrained Body Movement	X						X		X	
HS3132	Head Transient Acceleration Limits	X						X			
HS3133	Sound Pressure Level (SPL) Limits for Waste Management System	X	X								X
HS3134	Speech Interference Level Limit for Pre-Launch and Post-Landing	X						X			X
HS4002	Corners and Edges Exposed during Nominal Operations	X	X				X	X	X		X
HS4003	Corners and Edges Exposed during Maintenance	X	X					X	X		X
HS4004	Corners and Edges of Loose Equipment	X	X					X	X		X
HS4005	Burrs	X	X				X	X	X		X
HS4006	Sharp Items	X	X				X	X	X		X
HS4007	Interior Item Restraints	X	X					X	X		X
HS4008	Electrical Hazard Potential	X	X					X	X		X
HS4008B	Chassis Leakage Current - Nonpatient Equipment	X	X					X	X		X
HS4008C	Chassis Leakage Current - Patient Equipment	X	X					X	X		X
HS4012	Hot Touch Temperature Limit	X	X					X	X		X
HS4012A	Cold Touch Temperature Limit	X	X					X	X		X
HS4019	Fire Suppression Portability	X	X						X		X
HS4021	Pinch Points	X	X				X	X	X		X
HS4022	Emergency	X	X				X	X	X		X

Requirement	Requirement Name	REQUIREMENTS								VERIFICATIONS		
		Orion	Altair	Ares I	Ares V	MS	GO	EVA	FCE	LEVEL II	LEVEL III	
	Prevention											
HS6002	Cross-Contamination Separation	X	X									
HS6003	Heating	X	X							X		X
HS6004	Rehydration	X	X							X		X
HS6005	In-Flight Food Preparation Time	X	X								X	
HS6009	Personal Hygiene Privacy	X	X									X
HS6010	Personal Hygiene Stowage	X	X									
HS6012	Personal Hygiene Trash	X	X									
HS6013	Vomitus Collection and Containment	X	X								X	
HS6014	Simultaneous Defecation and Urination	X	X					X				X
HS6016	Fecal Wipes	X	X					X				X
HS6017	Feces per Day	X	X					X				X
HS6020	Diarrhea per Event	X	X									X
HS6020C	Feces per Event	X	X									X
HS6020D	Diarrheal Events per Crewmember	X	X									X
HS6021	Urine Collection	X	X									X
HS6022	Urine Wipes	X	X									X
HS6023	Urine per Crewmember	X	X									X
HS6024	Urine per Hour	X	X									X
HS6025	Urine Rate	X	X									X
HS6025B	Urine per Day	X	X									X
HS6027	Full Body Visual Privacy	X	X									X
HS6028	Body Self-Inspection and Cleaning	X	X									
HS6029	Waste Management Odor Control	X	X							X		X
HS6030	Waste Management Stowage	X	X							X		X
HS6031	Waste Management Trash	X	X							X		
HS6032	Exercise Capability	X	X								X	
HS6035	Exercise Operational Envelope	X	X									X
HS6036	Thermal Environment During Exercise	X	X					X				X

Revision: E	Document No: CxP 70024
Release Date: 11/19/10	Page: 463 of 503
Title: Constellation Program Human-Systems Integration Requirements	

Requirement	Requirement Name	REQUIREMENTS								VERIFICATIONS	
		Orion	Altair	Ares I	Ares V	MS	GO	EVA	FCE	LEVEL II	LEVEL III
HS6081	DCS Over-Pressurization	X	X					X		X	
HS6082	Orthostatic Protection	X						X			X
HS6083	Medical Care Provider Access	X	X								X
HS6084	Patient Electrical Isolation	X	X								X
HS6085	Access to Medical Equipment	X	X								X
HS6086	Access to Deployed Medical Kits	X	X								X
HS6091	Denitrogenation	X	X					X		X	
HS6097	Communication Capabilities	X	X								X
HS6099	Personalized In-Flight Updates		X							X	
HS6100	DCS Event Pressure	X	X					X		X	
HS6101	Medical Care Capabilities	X	X					X	X	X	
HS6102	Lunar Surface Food Preparation Time		X						X		X
HS6104	Crew Sleep Accommodations	X	X						X		X
HS6105	Personal Hygiene Items								X		X
HS6106	Stowage Equipment Cover Restraint	X	X						X		X
HS7003	Handling Qualities for Manual Control – Level 1	X	X							X	
HS7004	Handling Qualities for Manual Control – Level 2	X	X							X	
HS7007	Consistent Crew Interfaces	X	X					X			
HS7009	Location Coding	X	X								X
HS7010	Field of View	X	X					X			X
HS7010A	Two-Crew Operations	X	X								X
HS7018	Viewing Critical Displays and Controls	X	X				X	X			
HS7018A	Viewing Frequently Used Displays and Controls	X	X					X			
HS7019	Functional Reach	X	X				X	X			X

Revision: E	Document No: CxP 70024
Release Date: 11/19/10	Page: 464 of 503
Title: Constellation Program Human-Systems Integration Requirements	

Requirement	Requirement Name	REQUIREMENTS								VERIFICATIONS	
		Orion	Altair	Ares I	Ares V	MS	GO	EVA	FCE	LEVEL II	LEVEL III
	Envelope										
HS7021	Reach for Critical Controls	X	X					X			
HS7021A	Reach for Frequently Used Controls	X	X					X			
HS7022	Functional Related Displays and Controls	X	X					X			
HS7023	Successive Operation of Displays and Controls	X	X					X			
HS7024	Control Spacing For Suited Operations	X	X					X			X
HS7027	Over 3 g	X						X			X
HS7028	Over 2 g	X						X			X
HS7029	Supports	X									X
HS7036	Labeling	X	X					X	X	X	
HS7044	Legibility	X	X					X	X		X
HS7049	Notifications	X	X					X			X
HS7049A	Manual Silencing	X	X					X			X
HS7055	Command Feedback	X	X								X
HS7058	Subsystem State Information	X	X					X			X
HS7058A	System Responsiveness for Discrete Inputs	X	X					X			X
HS7058B	System Responsiveness for Continuous Inputs	X	X					X			
HS7058C	Request for Information	X	X					X			
HS7058D	Request for Critical Information	X	X								X
HS7058E	Menu Update Time	X	X								X
HS7059	Task-Oriented Displays	X	X								X
HS7060	Subsystem-Oriented Displays	X	X								X
HS7060A	Viewing Simultaneous Task Information	X	X								
HS7061	Location within the Display Hierarchy	X	X								X
HS7063	Compatibility of Movement	X	X					X			X

Revision: E	Document No: CxP 70024
Release Date: 11/19/10	Page: 466 of 503
Title: Constellation Program Human-Systems Integration Requirements	

Requirement	Requirement Name	REQUIREMENTS								VERIFICATIONS	
		Orion	Altair	Ares I	Ares V	MS	GO	EVA	FCE	LEVEL II	LEVEL III
HS8003	ORU Maintenance Time	X	X					X			X
HS8003-Objective	ORU Replacement Time/Maintenance	X	X					X			
HS8004	LRU Removal and Replacement	X	X	X	X						
HS8005	Physical Features	X	X					X	X		X
HS8006	Labeling and Marking	X	X					X	X		X
HS8007	Interchangeability	X	X					X			X
HS8008	Connectors	X	X					X	X		X
HS8009	Visual Access	X	X					X			X
HS8010	Physical Access	X	X								X
HS8011	Cable Access	X	X	X	X						X
HS8013	External Service Points		X		X						X
HS8015	Maintenance Hazard	X	X					X	X		X
HS8016	Failure Notification	X	X								X
HS8017	No Fuses for Dynamic Flight Phases	X	X								X
HS8018	Circuit Breakers Instead of Fuses	X	X								
HS8020	Replacement Without Tools	X	X								X
HS8021	Replacement Without Component Removal	X	X								X
HS8022	Circuit Breaker Resetting	X	X								X
HS8023	Trip Indication	X	X								X
HS8024	Electrostatic Discharge	X	X					X	X		X
HS8026	Access Points	X	X					X			
HS8029	Fastener Heads	X	X					X	X		X
HS8030	Fastener Number and Variety	X	X					X	X		
HS8031	Captive Fasteners	X	X					X	X		X
HS8032	Equipment Isolation	X	X					X			X
HS8034	Hazardous Levels of Fluid Leakage	X	X					X			X
HS8037	Common Toolset	X	X					X	X		
HS8041	Microbial	X	X					X	X		X

Revision: E	Document No: CxP 70024
Release Date: 11/19/10	Page: 467 of 503
Title: Constellation Program Human-Systems Integration Requirements	

Requirement	Requirement Name	REQUIREMENTS								VERIFICATIONS		
		Orion	Altair	Ares I	Ares V	MS	GO	EVA	FCE	LEVEL II	LEVEL III	
	Contamination											
HS8042	Fungal Contamination	X	X					X	X			X
HS8043	Replacement of Air Filters	X	X									
HS8045	Visual Indication	X	X					X	X			X
HS8046	Connector Mating Indication	X	X					X	X			X
HS8047	Unique Identification Labeling	X	X					X	X		X	
HS8048	Visual Line of Sight	X	X	X	X							
HS8051	Condensation Prevention on Interior Surfaces	X	X									X
HS8052	Tool Clearance	X	X					X	X			X
HS8053	Disturbance of Equipment	X	X					X				
HS8054	Tool Usage	X	X					X	X			X
HS8055	Crew Control of Power	X	X					X				X
HS9014	Data Rate	X	X					X				
HS9018	Locations of Data	X	X						X			X
HS9019	Wired Network	X	X									X
HS9020	Wireless Network		X									X
HS9021	Crew Operability	X	X									X
HS9025	Displaying Electronic Procedures System	X	X									X
HS9025A	Cueing Electronic Procedures System	X	X									X
HS9026	Current Procedure Step	X	X									X
HS9027	Completed Procedure Steps	X	X									X
HS9028	Crew Notification of Required Procedure Action	X	X									X
HS9029	Annunciation Hierarchy	X	X					X				X
HS9029A	Annunciation Prioritization	X	X					X				X
HS9030	Visual and Auditory Annunciation	X	X					X				X
HS9032	Distinctiveness of Annunciations	X	X					X				X

Revision: E	Document No: CxP 70024
Release Date: 11/19/10	Page: 468 of 503
Title: Constellation Program Human-Systems Integration Requirements	

Requirement	Requirement Name	REQUIREMENTS								VERIFICATIONS		
		Orion	Altair	Ares I	Ares V	MS	GO	EVA	FCE	LEVEL II	LEVEL III	
HS9032A	Loss of Annunciation Capability	X	X					X			X	
HS9037	Decomposition of Chemicals	X	X					X	X			X
HS9040	Data Fidelity	X	X					X				X
HS9042A	Manual Information Capture and Transfer								X			X
HS10001	Maintainability Without Deintegration	X	X	X	X							X
HS10002	Work Envelope Volumes	X	X	X	X							X
HS10004	Reach Envelope Volumes	X	X	X	X							X
HS10006	Ground Crew Visual Access	X	X	X	X							X
HS10008	Ground Anthropometry, Biomechanics, and Strength	X	X	X	X						X	
HS10009	Maintainability Without Disabling Subsystems	X	X	X	X							
HS10010	Fuse/Circuit Indication	X	X	X	X							X
HS10011	Appropriate Clothing and Equipment	X	X	X	X							X
HS10012	LRU Installation	X	X	X	X							X
HS10013	LRU Mounting/Alignment Labels/Codes	X	X	X	X							X
HS10014	LRU Interchangeability	X	X	X	X							X
HS10015	Connector Mismatching	X	X	X	X							X
HS10017	Connector Mating Labels	X	X	X	X							X
HS10019	Maintenance Without Damage	X	X	X	X							X
HS10020	Fluid Management	X	X	X	X							X
HS10021	Fluid Spillage Control	X	X	X	X							X
HS10022	System Safing Controls	X	X	X	X							X
HS10023	Equipment Protection	X	X	X	X			X				
HS10024	Tool Clearances	X	X	X	X							X
HS10025	Inspection Access	X	X	X	X							X
HS10026	Captive Fasteners	X	X	X	X							

Requirement	Requirement Name	REQUIREMENTS								VERIFICATIONS	
		Orion	Altair	Ares I	Ares V	MS	GO	EVA	FCE	LEVEL II	LEVEL III
HS10027	Ventilation Openings	X	X	X	X						X
HS10028	Toolset	X	X	X	X						X
HS10029	Safety Displays	X	X	X	X						X
HS10030	Ground Processing Hardware Access	X	X	X	X						X
HS10031	LRU Tracking Labels	X	X	X	X						X
HS10032	LRU Labeling	X	X	X	X						X
HS10033	Hazards Labeling	X	X	X	X			X	X		X
HS10039	Labeling	X	X	X	X						X
HS10042	LRU Protrusions	X	X	X	X						X
HS10043	Protrusion Label/Support	X	X	X	X						X
HS10045	LRU Weight Limit	X	X	X	X						X
HS10047	Work Station Layout Interference	X	X	X	X						
HS10048	Work Station Layout Sequential Operations	X	X	X	X						
HS10050	Consistent Crew Interfaces	X	X	X	X						
HS10051	Legibility	X	X	X	X						X
HS10052	Written Text	X	X	X	X						X
HS10053	Use of Color	X	X	X	X						
HS10054	LRU Removal Without Component Removal	X	X	X	X						
HS10055	Ground Labeling: Non-Interference with Flight Labels	X	X					X	X		X

Revision: E	Document No: CxP 70024
Release Date: 11/19/10	Page: 470 of 503
Title: Constellation Program Human-Systems Integration Requirements	

ALLOCATION MATRIX (CONCLUDED)

Requirement	Requirement Name	REQUIREMENTS								VERIFICATIONS	
		Orion	Altair	Ares I	Ares V	MS	GO	EVA	FCE	LEVEL II	LEVEL III
HS11000	Suit Pressure Set-Point Selection	X	X					X			X
HS11001	Suit Pressure Pause	X	X					X			X
HS11002	Control of Heat Stored by Crewmembers During EVA and Pre-launch	X	X					X			X
HS11004	Stowage for Suit Dosimeters							X			X
HS11005	Visual Field of View for a Suited Crewmember							X			X
HS11006	Optical Quality for Suited Crewmembers							X			X
HS11007	In-Suit Nutrition During Surface EVA Operations							X	X		X
HS11008	In-Suit Nutrition During Unpressurized Vehicle Survival							X	X		X
HS11009	In-Suit Hydration During EVA							X			X
HS11010	In-Suit Hydration during IVA	X						X	X		X
HS11011	Vomitus in the Suit	X	X					X			
HS11012	Nominal Urine Collection in the Suit							X			X
HS11013	Urine Collection - Suited Contingency							X			X
HS11014	Feces Collection - Suited Contingency							X			X
HS11015	Measurement of Physiological Parameters	X	X					X		X	
HS11016	Display of Physiological Parameters	X	X					X		X	
HS11017	Alert for Off-Nominal Physiological Parameters	X	X					X		X	
HS11018	Telemetry of Physiological	X	X					X		X	

Revision: E	Document No: CxP 70024
Release Date: 11/19/10	Page: 471 of 503
Title: Constellation Program Human-Systems Integration Requirements	

Requirement	Requirement Name	REQUIREMENTS								VERIFICATIONS	
		Orion	Altair	Ares I	Ares V	MS	GO	EVA	FCE	LEVEL II	LEVEL III
	Parameters										
HS11019	Maintain Suit Pressure Set-Point	X	X					X			X
HS11022	Crew Accessibility to Suit Temperature Controls							X			X
HS11023	Suited Radiation Dose Equivalent Monitoring							X		X	
HS11024	Suited Radiation Absorbed Dose Monitoring							X		X	

Revision: E	Document No: CxP 70024
Release Date: 11/19/10	Page: 472 of 503
Title: Constellation Program Human-Systems Integration Requirements	

APPENDIX K CREW INTERFACES

K1.0 HARDWARE AND SOFTWARE CONTROLS - COMPATIBILITY OF MOVEMENT

TABLE K1-1 - INPUT-OUTPUT COMPATIBILITY

Device	Direction of Movement and Result
Knobs:	
Continuous and discrete position rotary	Turn clockwise with hand or fingers – turn function on, increase value, move discrete cursor right, move displayed page left Turn counterclockwise with hand or fingers – turn function off, decrease value, move discrete cursor left, move displayed page right
Ganged	Turn each individual knob clockwise with hand or fingers – turn function on, increase value, move discrete cursor right, move displayed page left Turn each individual knob counterclockwise with hand or fingers – turn function off, decrease value, move discrete cursor left, move displayed page right
Thumbwheels or scroll wheels (operated by brushing/turning the edge of the wheel):	
Vertical wheel orientation	Move thumbwheel/scroll wheel edge forward with thumb or finger – turn function on, increase value, move a discrete cursor up, move displayed page down Move thumbwheel/scroll wheel edge backward with thumb or finger – turn function off, decrease value, move a discrete cursor down, move displayed page up
Horizontal wheel orientation	Move thumbwheel/scroll wheel edge right with thumb or finger – turn function on, increase value, move a discrete cursor right, move displayed page left Move thumbwheel/scroll wheel edge left with thumb or finger – turn function off, decrease value, move a discrete cursor left, move displayed page right

Revision: E	Document No: CxP 70024
Release Date: 11/19/10	Page: 473 of 503
Title: Constellation Program Human-Systems Integration Requirements	

Device	Direction of Movement and Result
Handwheels (operated by grasping the wheel's perimeter and turning) Note: Excludes valve wheels	Rotate handwheel clockwise with hand – turn function on, increase the value, move discrete cursor right, move displayed page left Rotate handwheel counterclockwise with hand – turn function off, decrease value, move discrete cursor left, move displayed page right
Pedals	Apply pressure to pedal with foot – turn function on, engage action, increase value. Reduce pressure to pedal with foot – turn function off, disengage action, decrease value
Momentary pushbuttons	Press and release to activate object or select menu item Press to activate function; release to deactivate function
Rocker switches:	
Vertical rocker orientation	Depress upper wing with finger – turn function on, increase value, move discrete cursor up, move displayed page down Depress lower wing with finger – turn function off, decrease value, move discrete cursor down, move displayed page down
Horizontal switch orientation	Depress right wing with finger – turn function on, increase value, move discrete cursor right, move displayed page left Depress left wing with finger – turn function off, decrease value, move discrete cursor left, move displayed page right
Push-pull controls	Pull control with hand – turn function on Push control with hand – turn function off
Slide/toggle switches:	
Vertical switch orientation	Slide/flip switch forward with fingers – turn function on or increase value Slide/flip switch backward with fingers – turn function off or decrease value
Horizontal switch orientation	Slide/flip switch right with fingers – turn function on or increase value Slide/flip switch left with fingers – turn function off or decrease value

Revision: E	Document No: CxP 70024
Release Date: 11/19/10	Page: 474 of 503
Title: Constellation Program Human-Systems Integration Requirements	

INPUT-OUTPUT COMPATIBILITY (CONCLUDED)

Device	Direction of Movement and Result
Continuous cursor control devices (joystick, mouse, trackball, etc.)	<p>Move device forward with hand – cursor moves up, displayed page moves down</p> <p>Move device backward with hand – cursor moves down, displayed page moves up</p> <p>Move device left with hand – cursor moves left, displayed page moves right</p> <p>Move device right with hand – cursor moves right, displayed page moves left</p> <p>Move device diagonally with hand in any direction – cursor moves diagonally in the same direction as the device's movement, displayed page moves diagonally opposite</p>
Discrete cursor control devices (arrow keys, castle switches)	<p>Press/deflect up key, switch, or button with finger – cursor moves up, displayed page moves down</p> <p>Press/deflect down key, switch, or button with finger – cursor moves down, displayed page moves up</p> <p>Press/deflect right key, switch, or button with finger – cursor moves right, displayed page moves left</p> <p>Press/deflect left key, switch, or button with finger – cursor moves left, displayed page moves right</p> <p>(If diagonal capability exists) Press/deflect key, switch, or button diagonally with hand in any direction – cursor moves diagonally in the same direction as the device's movement; displayed page moves diagonally opposite</p>
Rotational Hand Controller (RHC)	<p>Pivot controller forward – pitch vehicle down</p> <p>Pivot controller backward – pitch vehicle up</p> <p>Pivot controller right – roll vehicle right</p> <p>Pivot controller left – roll vehicle left</p> <p>Rotate control clockwise with hand – yaw vehicle right</p> <p>Rotate control counterclockwise with hand – yaw vehicle left</p>
Translational Hand Controller (THC)	<p>Push in on control with hand – move vehicle forward</p> <p>Pull out on control with hand – move vehicle backward</p> <p>Push right on control with hand – move vehicle to the right</p> <p>Push left on control with hand – move vehicle to the left</p> <p>Push up on the control with hand – move vehicle up</p> <p>Push down on the control with hand – move vehicle down</p>

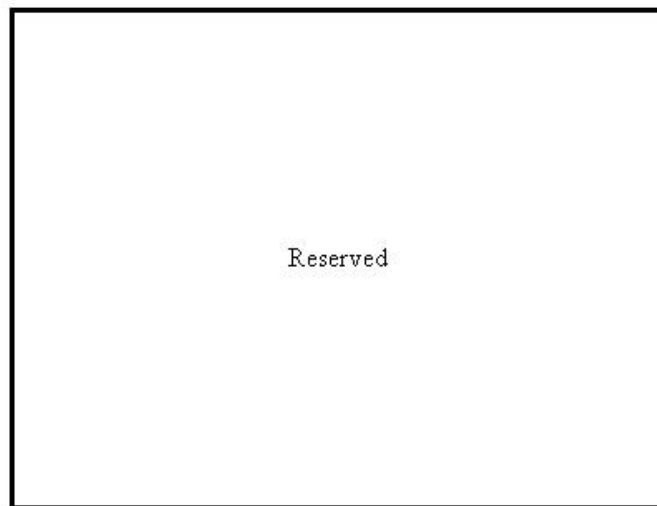
NOTE: Movement directions are from the user's nominal perspective. When a control affects a cursor or an indicator on an electronic display, the control/display

Revision: E	Document No: CxP 70024
Release Date: 11/19/10	Page: 475 of 503
Title: Constellation Program Human-Systems Integration Requirements	

relationship of up and down movements may be dependent on the angle of the control mounting (with respect to the body and display) or on the prior experience of the user. The information in the table above assumes that the control is mounted in the horizontal plane and the display is in the vertical plane at roughly 90° to the body. Usability testing may be necessary to confirm the best mapping.

K2.0 HARDWARE AND SOFTWARE CONTROLS - CODING FOR EMERGENCY AND CRITICAL CONTROLS

TABLE K2-1 - EMERGENCY CODING TABLE



Reserved

Revision: E	Document No: CxP 70024
Release Date: 11/19/10	Page: 476 of 503
Title: Constellation Program Human-Systems Integration Requirements	

K3.0 CAUTION AND WARNING - ALERT ANNUNCIATIONS

TABLE K3-1 - ALERT ANNUNCIATION

Alert Type	Priority	Alert Annunciation
<p>Emergency – Fire</p> <p>Specifically identified life threatening warning event that requires immediate action.</p>	1	<p>Siren: square wave frequency modulated over a period of 5 s from 650 Hz – 1,500 Hz – 650 Hz; followed by 2 s silent interval; repeat until terminated.</p> <p>Notes: 1, 2, 3, 4, 5, 6</p> <p>(Corresponds to red symbology on display and lights.)</p>
<p>Emergency – Pressure Loss</p> <p>Specifically identified life threatening warning event that requires immediate action.</p>	2	<p>Klaxon: 2,560 Hz tone, 2.1 ms on, 1.6 ms off, mixed with 256 Hz tone. Two digital pulse trains shall be logically OR'ed and the DC component removed. The first pulse train shall be a 50% duty cycle square wave at 2,560 Hz which is enabled for 2.1 ms and set to logic "0" for 1.6 ms. The second pulse train shall be a 50% duty cycle square wave at 256 Hz which is enabled for 210 ms and set to logic "0" for 70 ms. Sequence contains 4 iterations of 280 ms on-off pulse (210 ms ON, 70 ms OFF), followed by 280 ms silence. This sequence is , repeated 3 times separated by 1.5 s silent interval; repeat until terminated .</p> <p>Notes: 1, 4, 5, 6</p> <p>(Corresponds to red symbology on display and lights.)</p>
<p>Warning</p> <p>Event that requires immediate action because it has the potential to become a life/mission threat.</p>	3	<p>Alternating tone (square wave), 400 Hz and 1,024 Hz at a 2.5 Hz modulation rate (400 Hz for 0.4 s then 1,024 Hz for 0.4 s, total 0.8 s); sequence contains two pairs of alternating square wave tones with total 1.6 s duration; sequence followed by 1 s silent interval; repeats 3 times followed by 3 s silent interval; repeat until terminated.</p> <p>Notes: 1, 2, 4, 5, 6</p> <p>(Corresponds to red symbology on display and lights.)</p>

Revision: E	Document No: CxP 70024
Release Date: 11/19/10	Page: 477 of 503
Title: Constellation Program Human-Systems Integration Requirements	

ALERT ANNUNCIATION (CONCLUDED)

Alert Type	Priority	Alert Annunciation
<p>Caution</p> <p>Event that needs attention, but not immediate action.</p>	4	<p>Continuous tone triangle wave (odd harmonics at amplitude reciprocal to harmonic number) 512 Hz of duration 1 s. Subsequent repetitions consist of 1 s of silent interval followed by the 1 s tone. Number of repetitions (or total duration) may be set by the crewmember, from 1 to 30 repetitions (or 1 s to 60 s).</p> <p>Notes: 1, 2, 3, 4, 5, 6</p> <p>(Corresponds to yellow symbology on display and lights.)</p>
<p>Advisory</p> <p>Message describing a routine event, situation, or action, or an off-nominal event that does not meet the criteria for a Caution.</p>	5	<p>No audio.</p> <p>(Corresponds to blue symbology on display)</p>

NOTES:

1. To prevent 'startle effect', the onset of all alarms should be preceded by a 'pre-alarm', whereby the same alarm is enunciated 10 dB lower than its final calibrated level (e.g., +15 dB(A) with respect to the level of the background noise). This may be accomplished using separate start and loop start addresses to the digital buffer (see Appendix K, figure Pre-Alarm and Alarm Start/Loop Start for Non-Startle).
2. To prevent 'startle effect', the onset of the amplitude envelope of alarms should have a rise time from 0 to maximum amplitude of 200 ms (see Appendix K, figure Onset of the Amplitude Envelope of Alarms for Non-Startle).
3. This siren is based on the standard 'wail' siren used by law enforcement that mimics historical 'wind-up' sirens. Frequencies have been adjusted to conform to recommended practice "Emergency Vehicle Sirens-SAE J1849 August 1995", Society of Automotive Engineers (SAE).
4. Rather than sounding continuously, the alarms have silent intervals in between sound bursts to aid problem solving under high-stress conditions. The lower the priority of the alarm, the longer the 'inter-burst silent interval' (ranges from 2 – 4 s).
5. Alarms shall be prioritized per the second column so that higher priority annunciations postpone or cancel any lower priority alert from sounding at the same time.
6. Any verbal annunciation used must have NASA approval.

Revision: E	Document No: CxP 70024
Release Date: 11/19/10	Page: 478 of 503
Title: Constellation Program Human-Systems Integration Requirements	

APPENDIX L NIOSH LIFTING EQUATION

CALCULATIONS

The revised lifting equation for calculating the Recommended Weight Limit (RWL) is based on a multiplicative model that provides a weighting for each of six variables:

$$RWL = LC \times HM \times VM \times DM \times AM \times FM \times CM$$

where:

LC = Load Constant (51 pounds)

HM = Horizontal Multiplier (10/H)



FIGURE L-1 - HORIZONTAL MEASUREMENT FIGURE

Horizontal location of the hands (H): The horizontal location of the hands at both the start (origin) and end (destination) of the lift must be measured. The horizontal location is measured as the distance from the mid-point between the employee's ankles to a point projected on the floor directly below the mid-point of the hands grasping the object (the middle knuckle can be used to define the mid-point). The horizontal distance should be measured when the object is lifted (when the object leaves the surface).

$$VM = \text{Vertical Multiplier } [1 - (0.0075|V-30|)]$$

Vertical location of the hands (V): The vertical location is measured from the floor to the vertical mid-point between the two hands (the middle knuckle can be used to define the mid-point).

$$DM = \text{Distance Multiplier } [0.82 + (1.8/D)]$$

Travel Distance of the load (D): The total vertical travel distance of the load during the lift is determined by subtracting the vertical location of the hands (V) at the start of the

Revision: E	Document No: CxP 70024
Release Date: 11/19/10	Page: 479 of 503
Title: Constellation Program Human-Systems Integration Requirements	

lift from the vertical location of the hands (V) at the end of the lift. For lowering, the total vertical travel distance of the load is determined by subtracting the vertical location of the hands (V) at the end of the lower from the vertical location of the hands (V) at the start of the lower.

$$AM = \text{Asymmetric Multiplier } [1 - (0.0032A)]$$

Asymmetry Angle (A): The angular measure of the perpendicular line that intersects the horizontal line connecting the mid-point of the shoulders and the perpendicular line that intersects the horizontal line connecting the outer mid-point of the hips.

$$FM = \text{Frequency Multiplier}$$

(See Appendix L, table Frequency Multiplier Table (FM))

Lifting Frequency (F): The average lifting frequency rate, expressed in terms of lifts per minute, must be determined. The frequency rate can be determined by observing a typical 15-minute work period and documenting the number of lifts performed during this time frame. The number of lifts observed is divided by 15 to determine the average lifts per minute. Duration is measured using the following categories: Short (less than 1 hour), Moderate (1 to 2 hours), and Long (2 to 8 hours).



FIGURE L-2 - MEASURE OF ASYMETRY ANGLE A

TABLE L-1 - FREQUENCY MULTIPLIER TABLE (FM)

Frequency Lifts/min (F) ‡	Work Duration					
	<1 Hour		>1 but <2 Hours		>2 but <8 Hours	
	V < 30 †	V > 30	V < 30	V > 30	V < 30	V > 30
< 0.2	1.00	1.00	.95	.95	.85	.85
0.5	.97	.97	.92	.92	.81	.81
1	.94	.94	.88	.88	.75	.75
2	.91	.91	.84	.84	.65	.65
3	.88	.88	.79	.79	.55	.55
4	.84	.84	.72	.72	.45	.45
5	.80	.80	.60	.60	.35	.35
6	.75	.75	.50	.50	.27	.27
7	.70	.70	.42	.42	.22	.22
8	.60	.60	.35	.35	.18	.18
9	.52	.52	.30	.30	.00	.15
10	.45	.45	.26	.26	.00	.13
11	.41	.41	.00	.23	.00	.00
12	.37	.37	.00	.21	.00	.00
13	.00	.34	.00	.00	.00	.00
14	.00	.31	.00	.00	.00	.00
15	.00	.28	.00	.00	.00	.00
> 15	.00	.00	.00	.00	.00	.00

† Values of V are in inches.

‡ For lifting less frequently than once per 5 minutes, set F = 2 lifts/minute.

CM = Coupling Multiplier (See Appendix L, table Coupling Table)

Object coupling (C): The classification of the quality of the hand-to-object coupling (rated as Good, Fair, or Poor).

TABLE L-2 - COUPLING TABLE

<p align="center">GOOD CM = 1.00</p>	<p align="center">FAIR V < 30" then CM = 0.95 V > or = to 30" then CM = 1.00</p>	<p align="center">POOR CM = 0.90</p>
<p>1. For containers of optimal design, such as some boxes, crates, etc., a "Good" hand-to-object coupling would be defined as handles or hand-hold cut-outs of optimal design.</p>	<p>1. For containers of optimal design, a "Fair" hand-to-object coupling would be defined as handles or hand-hold cut-outs of less than optimal design.</p>	<p>1. Containers of less than optimal design or loose parts or irregular objects that are bulky or hard to handle.</p>
<p>2. For loose parts or irregular objects, which are not usually containerized, such as castings, stock, supply materials, etc., a "Good" hand-to-object coupling would be defined as a comfortable grip in which the hand can be easily wrapped around the object.</p>	<p>2. For containers of optimal design with no handles or hand-hold cut-outs or for loose parts or irregular objects, a "Fair" hand-to-object coupling is defined as a grip in which the hand can be flexed approximately 90 degrees.</p>	<p>2. Lifting non-rigid bags (i.e., bags that sag in the middle).</p>

Help using the lifting formula is available through the Directorate of Technical Support.

Refer to Appendix L, figure Lifting Analysis Worksheet. The lifting analysis should be performed using both the average and maximum weights.

LIFTING ANALYSIS WORKSHEET														
DEPARTMENT _____						JOB DESCRIPTION _____								
JOB TITLE _____						_____								
ANALYST'S NAME _____						_____								
DATE _____														
STEP 1. Measure and record task variables														
Object Weight (lbs)		Hand Location				Vertical Distance	Asymmetric Angle (deg.)		Frequency Rate	Duration	Object Coupling			
		Origin		Dest			Origin	Destination	lifts/min	Hrs				
L(AVG)	L(MAX)	H	V	H	V	D	A	A	F		C			
STEP 2. Determine the multipliers and compute the RWLs														
RWL = LC x HM x VM x DM x AM x FM x CM														
ORIGIN	RWL =	<input type="text" value="51"/>	x	<input type="text"/>	x	<input type="text"/>	x	<input type="text"/>	x	<input type="text"/>	x	<input type="text"/>	=	<input type="text"/>
DEST.	RWL =	<input type="text" value="51"/>	x	<input type="text"/>	x	<input type="text"/>	x	<input type="text"/>	x	<input type="text"/>	x	<input type="text"/>	=	<input type="text"/>
STEP 3. Compute the LIFTING INDEX														
ORIGIN	LIFT INDEX	$\frac{\text{OBJECT WEIGHT}}{\text{RWL}} = \underline{\hspace{2cm}} = \underline{\hspace{2cm}}$												
DESTINATION	LIFT INDEX	$\frac{\text{OBJECT WEIGHT}}{\text{RWL}} = \underline{\hspace{2cm}} = \underline{\hspace{2cm}}$												

FIGURE L-3 - LIFTING ANALYSIS WORKSHEET

Revision: E	Document No: CxP 70024
Release Date: 11/19/10	Page: 483 of 503
Title: Constellation Program Human-Systems Integration Requirements	

APPENDIX M WINDOW VIEW OBSTRUCTION KEEP-OUT ZONES

Inboard Window Obscuration Exclusion Zone

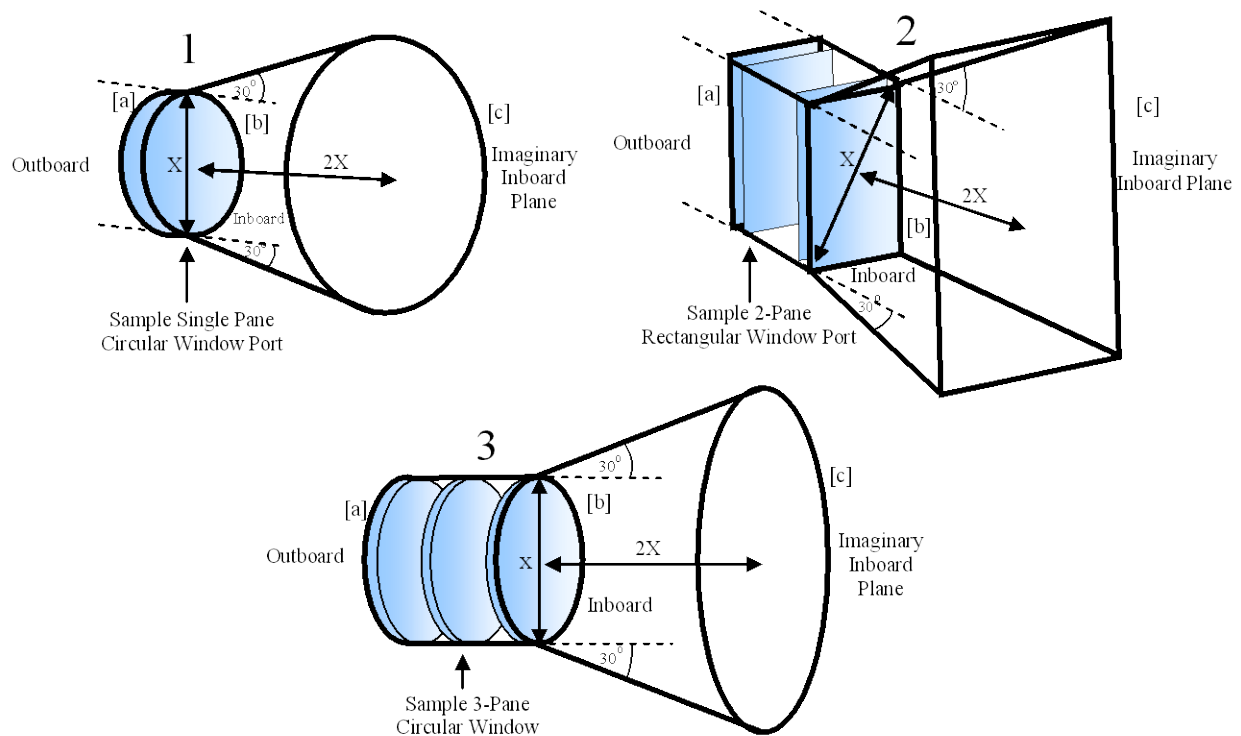
With respect to the vehicle on which the window is installed, the view through any window shall not be obscured or obstructed in any way from within a volume circumscribed by:

1. The perimeter of the clear viewing area of the outboard-most surface of the window, shown as [a] on the sample diagrams in Appendix M, figure Inboard Window View No Obstruction Zone.
2. The perimeter of the clear viewing area of the inboard-most surface of the window, shown as [b] on the sample diagrams in Appendix M, figure Inboard Window View No Obstruction Zone.
3. An imaginary plane located directly inboard from and parallel to the window panes at a distance equal to twice the largest clear viewing area dimension from the inboard-most surface of the window but in no case less than 0.3 m (~1.0 ft.) nor more than 1.5 m (~59 inches), shown as [c] on the sample diagrams in Appendix M, figure Inboard Window View No Obstruction Zone.
4. The surface that connects 2 and 3 above that slopes 30 degrees radially outward from the inboard facing normals to 2 above.

Exceptions:

1. Hardware designed and intended to protect and cover the window when the window is not in use.
2. Hardware or equipment used in conjunction with piloting such as a Head's Up Display, Crew Optical Alignment System, or other similar equipment. Any obstruction or obscuration of the view through the window by such hardware or equipment should be minimized.
3. The inner mold line/hull structure and other windows.
4. Instrumentation applied to the window itself within 13 mm (~ 0.5 in) of the perimeter of the clear viewing area.
5. An analysis is performed with respect to the vehicle to establish a smaller inboard window obscuration exclusion zone to accommodate specific program and vehicle requirements.

Revision: E	Document No: CxP 70024
Release Date: 11/19/10	Page: 484 of 503
Title: Constellation Program Human-Systems Integration Requirements	



Note: The inboard window view no obstruction zone extends to the outboard-most window surface. Drawings are not to scale and are for illustrative purposes only.

FIGURE M-1 - INBOARD WINDOW VIEW NO OBSTRUCTION ZONE

Outboard Window Obscuration Exclusion Zone

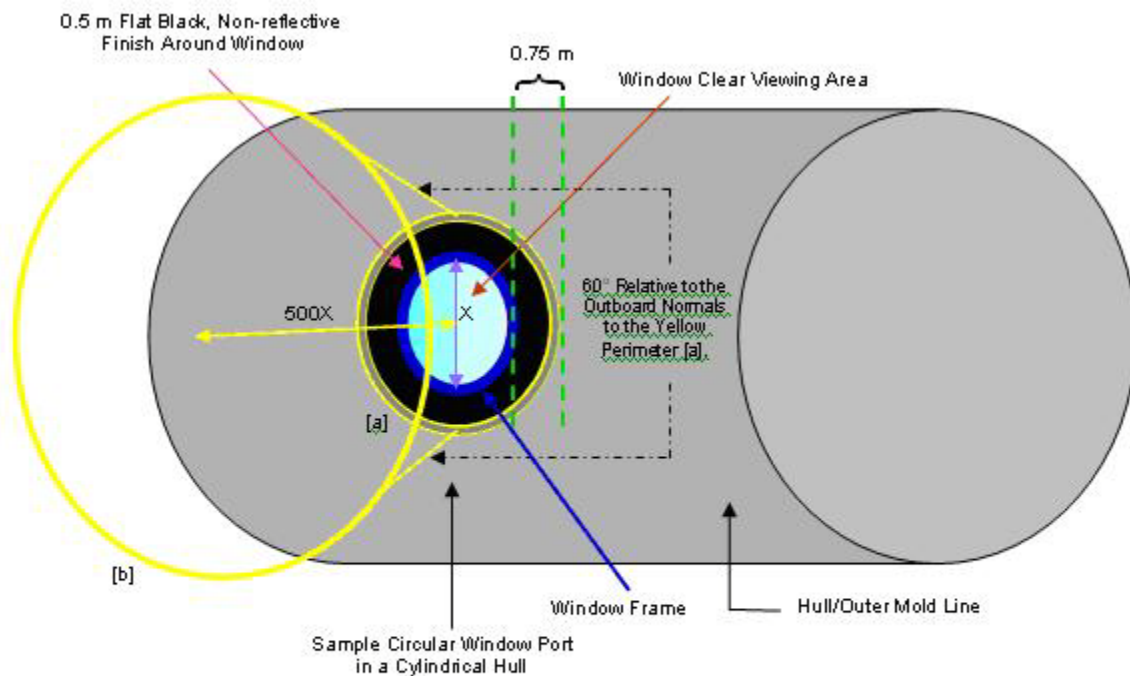
With respect to the vehicle on which it is installed the exterior view through any window shall not be obscured or obstructed in any way within a volume circumscribed by:

1. A 0.75 m (~2.5 ft) perimeter around the window on the outer mold line measured from the outer edge (perimeter) of the clear viewing area, shown as [a] in Appendix M, figure Outboard Window View No Obstruction Zone.
2. An imaginary plane located directly outboard from and parallel to the window panes at a distance equal to five hundred times the largest clear viewing area dimension from the outboard-most surface of the window, shown as [b] in Appendix M, figure Outboard Window View No Obstruction Zone.
3. The surface that connects 1 and 2 above that slopes 60 degrees radially outward from the outboard facing normals to 1 above.

Exceptions:

Revision: E	Document No: CxP 70024
Release Date: 11/19/10	Page: 485 of 503
Title: Constellation Program Human-Systems Integration Requirements	

1. Hardware designed and intended to protect and cover the window when the window is not in use.
2. Hardware or equipment used in conjunction with piloting such as a Head's Up Display, Crew Optical Alignment System, or other similar equipment. Any obstruction or obscuration of the view through the window by such hardware or equipment should be minimized.
3. The outer mold line/hull structure and other windows.
4. Instrumentation applied to the window itself within 13 mm (~ 0.5 in) of the perimeter of the clear viewing area.
5. An analysis is performed with respect to architecture integration to establish a smaller outboard window obscuration exclusion zone to accommodate specific program and unique architectural element integration requirements.



Note: The outboard window view no obstruction zone extends outboard from the outer mold line. Drawing is not to scale and is for illustrative purposes only.

FIGURE M-2 - OUTBOARD WINDOW VIEW NO OBSTRUCTION ZONE

Revision: E	Document No: CxP 70024
Release Date: 11/19/10	Page: 486 of 503
Title: Constellation Program Human-Systems Integration Requirements	

APPENDIX N OCCUPANT PROTECTION

N1.0 INTRODUCTION

Many parameters affect the likelihood of injury during dynamic flight events, including extrinsic factors such as g-loading, velocity change, rate of acceleration onset, acceleration rise time, bone and soft tissue compression, extension, shear force magnitudes and directions, deflections of the body components, etc., as well as intrinsic factors of the crew such as age, gender, physical condition, and degree of muscle tension. Proper support and restraint of the body components can reduce this risk of injury and need to be addressed by both the vehicle and the flight suit system. The Brinkley Dynamic Response Model currently used for occupant protection has its basis in tests with volunteer subjects, tests using post mortem human subjects, accidental injuries, and injuries incurred during emergency escape from aircraft; therefore, it provides point estimates for injury probability based on the acceleration-time histories.

Occupant protection requirements in this document are included to control hazards presented by excessive crew loads due to high accelerations or insufficient crew restraint. Structural failure, especially during off-nominal landing events, is an additional hazard mode that may threaten occupant safety. It is important that both hazard elements be controlled in order to minimize crew injury during vehicle acceleration and deceleration events.

Structural failure (primary or secondary) may present an occupant protection hazard by impinging upon occupant volume in such a way as to injure crewmembers. In order to protect against this hazard, it is necessary to define a "crew occupiable volume" or "survivable volume" that cannot be breached and, through hazard analysis and other methods, ensure that vehicle structure, subsystems, and components do not create critical or catastrophic hazard risks by entering this volume. It is also important to ensure that implementation of protection against these hazards does not impede egress or otherwise create unintended additional risks. This type of hazard is protected against through CxP 72000, Constellation Program System Requirements for the Orion System, with table Orion Landing Performance Criteria, which defines certified landing conditions and impact condition probability criteria. This hazard is also protected against through CxP 70135, Constellation Program Structural Design and Verification Requirements.

N2.0 BRINKLEY DYNAMIC RESPONSE MODEL

Human testing of aircraft ejection seats and spacecraft seats, as well as operational experience with emergency escape systems, has enabled the highest fidelity for injury prediction using the Brinkley model in the +Gz axis. The probability-of-injury assessments were made based upon the mean values of groups of replicate tests and operational ejection

Revision: E	Document No: CxP 70024
Release Date: 11/19/10	Page: 487 of 503
Title: Constellation Program Human-Systems Integration Requirements	

outcomes. The probabilities were determined by best fit of the mean values to a normal distribution curve and subsequent calculation of 95 percent confidence intervals for each set of conditions. The mean of 50% probability-of-injury for +z axis is based upon an $n > 100$, yielding an interval for $p = .50$ and $n = 100$ is $.402 \leq p \leq .598$. Where $n = 89$ and $p = .11$, the interval is $.045 \leq p \leq .175$. The confidence intervals for the +z axis means became smaller for lower risk values (5% and lower). However, statistical uncertainty remains for the other axes; therefore, the probability of injury is provided as a relative scale as follows.

Human testing of aircraft ejection seats and spacecraft seats, as well as operational experience with emergency escape systems, has enabled the highest fidelity for injury prediction using the Brinkley model in the +Gz axis. The probability-of-injury assessments were made based on mean values of groups of replicate tests and operational ejection outcomes. The probabilities were determined by best fit of the mean values to a normal distribution curve and subsequent calculation of 95 percent confidence intervals for each set of conditions. The mean of 50% probability of injury for +z axis is based upon an $n > 100$, yielding an interval for $p = .50$ and $n = 100$ is $.402 \leq p \leq .598$. Where $n = 89$ and $p = .11$, the interval is $.045 \leq p \leq .175$. The confidence intervals for the +z axis means became smaller for lower risk values (5% and lower). However, statistical uncertainty remains for the other axes; therefore, the probability of injury is provided as a relative scale as follows:

Category	Approximate Risk
Low	0.5%
Medium	5.0%
High	50%

For further detail, the Brinkley Dynamic Response model is documented in the Advisory Group for Aerospace Research and Development (AGARD), CP-472, "Development of Acceleration Exposure Limits for Advanced Escape Systems." The Brinkley Dynamic Response model is validated for circumstances that meet all of the criteria below.

Accelerations of less than 0.5 sec (e.g., during liftoff, launch abort, landing impacts, and parachute deployments)

NOTE: Crewmembers restrained by a restraint system that includes, at a minimum, pelvic restraints, torso restraints, and anti-submarining restraints that provide occupant restraint no less than that of a conventional 5-point harness

Revision: E	Document No: CxP 70024
Release Date: 11/19/10	Page: 488 of 503
Title: Constellation Program Human-Systems Integration Requirements	

Seated crewmembers where seat padding or cushions preclude amplification of transient linear accelerations transmitted to the occupant

If these criteria are met, the Brinkley Dynamic Response model is valid to apply and the injury risk criterion, β , is calculated according to:

$$\beta = \sqrt{\left(\frac{DR_x(t)}{DR_x^{lim}}\right)^2 + \left(\frac{DR_y(t)}{DR_y^{lim}}\right)^2 + \left(\frac{DR_z(t)}{DR_z^{lim}}\right)^2}$$

where $DR_x(t)$, $DR_y(t)$, and $DR_z(t)$ are calculated using the Brinkley Dynamic Response model. The dimensionless dynamic response in each of the three axes given by:

$$DR = \omega_n^2 x / g$$

where x is defined by the spring deflection of the dynamic system (consisting of the seat and the body) along each axis given by:

$$\ddot{x} + 2\xi\omega_n\dot{x} + \omega_n^2 x = A$$

where:

- g = Acceleration of gravity
- \ddot{x} = Occupant's acceleration in inertial frame
- \dot{x} = Occupant's relative velocity with respect to the critical point shown in the seat coordinate system in Appendix N, figure Critical Point Definition of a Seated Occupant
- x = Displacement of the occupant's body with respect to the critical point shown in the seat coordinate system in Appendix N, figure Critical Point Definition of a Seated Occupant (A positive value represents compression)

of the body.)

ζ = damping coefficient ratio defined in Appendix N, table Model Coefficients

ω_n = un-damped natural frequency of the dynamic system defined in Appendix N, table Model Coefficients

A is the measured acceleration, per axis, of the seat at the critical point shown in Appendix N, figure Critical Point Definition of a Seated Occupant . Because the seat axis is not an inertial frame, rotational acceleration must be considered in terms of the linear components of the angular motion.

TABLE N2-1 - MODEL COEFFICIENTS

	X		Y		Z	
	eyeballs out	eyeballs in	eyeballs left	eyeballs right	eyeballs up	eyeballs down
	x< 0	x>0	y<0	y>0	z<0	z>0
ω_n	60.8	62.8	58.0	58.0	47.1	52.9
ζ	0.04	0.2	0.09	0.09	0.24	0.224

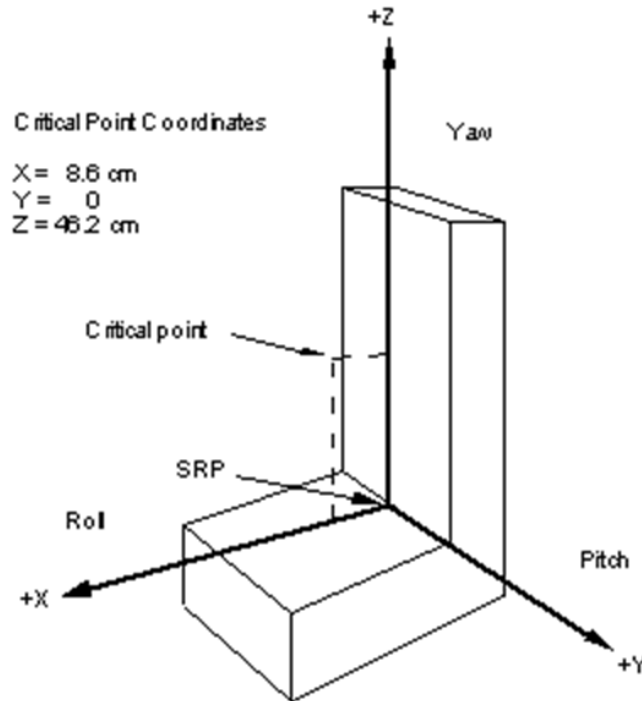


FIGURE N2-1 - CRITICAL POINT DEFINITION OF A SEATED OCCUPANT

Limits, DR_{lim} , are those given in Appendix N, table Dynamic Response Limits. The appropriate risk level will be determined by the Projects and concurred by the Program.

TABLE N2-2 - DYNAMIC RESPONSE LIMITS

DR level	X		Y		Z	
	eyeballs out	eyeballs in	eyeballs left	eyeballs right	eyeballs up	eyeballs down
	$DR_x < 0$	$DR_x > 0$	$DR_y < 0$	$DR_y > 0$	$DR_z < 0$	$DR_z > 0$
Low (deconditioned)	-28	35	-14 [-15]*	14 [15]*	-11.5	13.0
Low (Non-deconditioned)@	-28	35	-14 [-15]*	14 [15]*	-13.4	15.2
Medium (deconditioned)	-35	40	-17 [-20]*	17 [20]*	-14.1	15.4
Medium (Non-deconditioned)@	-35	40	-17 [-20]*	17 [20]*	-16.5	18.0
High (deconditioned)	-46	46	-22 [-30]*	22 [30]*	-17.5	19.5
High (Non-deconditioned)@	-46	46	-22 [-30]*	22 [30]*	-20.4	22.8

The table values assume a simple conventional (Apollo-like seat) restraint system.

* If lateral support is used (limiting side body movement), the values in [brackets] apply.

@ Use for healthy, non-deconditioned crew (e.g., launch abort cases)

Revision: E	Document No: CxP 70024
Release Date: 11/19/10	Page: 492 of 503
Title: Constellation Program Human-Systems Integration Requirements	

Table values were derived based on a review of the following: AGARD CP-472, NASA-TM-2008-215198, NASA-TN-D-7440, and NASA-TN-D-6539.

For Appendix N, table Dynamic Response Limits, use the injury risk criterion calculations, employing the above value in Appendix N, table Dynamic Response Limits for each corresponding risk level. If the β value calculated is >1.0 , then the next higher risk level DR in Appendix N, table Dynamic Response Limits must be used for the calculation.

To determine the injury risk criterion, Beta, as a function of time:

1. Find the acceleration at the critical point in each axis at time (t),
2. Solve the second order differential equation for the displacement (x) of the occupant,
3. Determine the dynamic response (DR(t)) for each axis at time (t), and
4. Determine Beta at time (t).

Using this process, increment time and repeat until the maximum Beta is found.

In this model, it is assumed that the total body mass that acts upon the vertebrae to cause deformation can be represented by a single mass.

Using the Dynamic Response model limits for accelerations of less than 0.5 sec (e.g., during nominal liftoff, launch abort, landing impact, and parachute deployment) provides the proper margins of safety for a healthy deconditioned crewmember. The Dynamic Response Model will provide an injury risk assessment in the event of either an Orion nominal or off-nominal failure or multiple failures. The desired Dynamic Response limits are low (approximately 0.5%) for all cases. The Brinkley very low category, which included modified DR limits, developed for ill/injured/unconscious crewmembers, is not applicable to Constellation Program vehicles, which do not have the medical return mission design mandate. If occupant protection principles are not properly applied and/or multiple off-nominal failures occur, loads could impart risks in the medium risk (approximately 5%) and high risk categories (approximately 50%) for risk of sustaining a serious or incapacitating injury.

These crew injury risk limit values are based on data from experiments in which the seat occupant was restrained to the seat and seat back by a lap belt, shoulder straps, and a strap or straps to prevent submarining of the pelvis or from operational escape statistics where similar restraint systems were used. During the experimental efforts the restraint

Revision: E	Document No: CxP 70024
Release Date: 11/19/10	Page: 493 of 503
Title: Constellation Program Human-Systems Integration Requirements	

system was adequately pre-tensioned to eliminate slack. Pyrotechnically powered inertial reels were used to position escape system occupants and to eliminate slack in the restraint. The restraint system was adequately pretensioned to eliminate slack. The +z axis limits assume that the seat cushion materials do not amplify the acceleration transmitted to the seat occupant. The +x axis limits presume that the seat occupant's head is protected by a flight helmet with a liner adequate to pass the test requirements of American National Standards Institute (ANSI) Z-90 (latest edition) or equivalent. These requirements assume that the crew will be similarly restrained during all events that might require application of the Brinkley model.

N3.0 Head Injury Criteria

Head Protection Criteria Formula:

$$HIC = [1 / (t_2 - t_1) \int_{t_1}^{t_2} a_r(t) dt]^{2.5} (t_2 - t_1)$$

Refer to 49CFR Part 571 for further detail concerning Head Injury Criteria (HIC) definitions and methodology.

Definition of HIC₁₅ and its calculation: For any two points in time t₁ and t₂, measured in milliseconds, during the event, which are separated by not more than a 15-millisecond time interval where t₁ is less than t₂, the head injury criterion (HIC₁₅) shall be determined using the resultant head acceleration at the center of gravity of the dummy head, a_r, measured in g's (g is the acceleration of gravity).

The maximum calculated HIC₁₅ value, which is unit-less, should not exceed 700.

TABLE N3-1 - HEAD INJURY CRITERIA

	0.5% risk level	2% risk level	5% risk level
Head Injury Criteria (HIC15)	300	500	700

As previously noted, 0.5% risk level corresponds to low risk posture, and 5% risk level corresponds to medium risk posture. The 2% risk level provided here is for reference only. The appropriate risk level for design is determined by the Projects and concurred by the Program.

Revision: E	Document No: CxP 70024
Release Date: 11/19/10	Page: 494 of 503
Title: Constellation Program Human-Systems Integration Requirements	

Table values were derived based on a review of the following: MIL-S-58095A, USAAVSCOM TR-89-D-22A, JSSG-2010-7, SAE J885, SAE PT-43, SFI, Inc. Specifications 31.1, 38.1, and 41.1, and AGARD CP-597.

N4.0 Human Tolerance Limits to Acceleration, Force, and Bending Moments

Acceleration, force, and bending moment human tolerance limits have been developed and applied for vehicle design standards, requirements, and guidelines in all US federal programs and many international vehicle design documents. Application of both whole-body and anatomically-specific human load limits to space vehicle design is the best method of implementing crew occupant protection principles that have proven to be essential in saving human lives during off-nominal and contingency vehicle operations.

TABLE N4-1 - HEAD ACCELERATION LIMITS

	0.5% risk			2% risk			5% risk		
	Small Female	50% Male	Large Male	Small Female	50% Male	Large Male	Small Female	50% Male	Large Male
Peak Head Acceleration (g) (deconditioned) ξ	119	112	109	151	142	138	166	155	151
Peak Head Acceleration (g) (Non-deconditioned)	138	130	127	176	165	160	193	180	175

Table values were derived based on a review of the following: MIL-S-58095A, USAAVSCOM TR-89-D-22A, JSSG-2010-7, SAE J885, SAE PT-43, SFI, Inc. Specifications 31.1, 38.1, and 41.1, AGARD CP-597, and Nahum and Melvin (2002).

TABLE N4-2 - NECK PROTECTION CRITERIA

	0.5% risk			2% risk			5% risk		
	Small Female	50% Male	Large Male	Small Female	50% Male	Large Male	Small Female	50% Male	Large Male
Peak neck (cervical) flexion	42	83	83	57	108	125	89	163	222

bending moment (Nm) (deconditioned) ξ									
Peak neck (cervical) flexion bending moment (Nm) (non-deconditioned)	49	96	96	66	126	145	104	190	258
Peak neck (cervical) lateral bending moment (Nm) (deconditioned) ξ	33	65	65	41	82	82	62	123	123
Peak neck (cervical) lateral bending moment (Nm) (non-deconditioned)	38	75	75	48	95	95	72	143	143
Peak Neck (cervical) extension bending moment (Nm) (deconditioned) ξ	15	34	42	27	49	67	28	56	75
Peak Neck (cervical) extension bending moment (Nm) (non-deconditioned)	17	39	49	31	57	78	33	65	87

Table values were derived based on a review of the following: JSSG-2010-7, SAE J885, SAE PT-43, SFI, Inc. Specification 38.1, DOT/FAA/AM-91/14, and Nahum and Melvin (2002).

TABLE N4-3 - TRANSIENT FORCE APPLICATION LIMITS

	0.5% risk			2% risk			5% risk		
	Small Female	50% Male	Large Male	Small Female	50% Male	Large Male	Small Female	50% Male	Large Male
Peak neck (cervical spine) axial tension (N) (Deconditioned) ξ	631	943	1,138	1,753	2,781	3,363	2,161	3,440	4,326
Peak neck (cervical spine) axial tension (N) (Non-deconditioned)	734	1,097	1,323	2,038	3,234	3,910	2,513	4,000	5,030
Peak neck (cervical spine) compression (N) (deconditioned) ξ	596	946	1,142	1,067	1,694	2,046	2,167	3,440	4,154
Peak neck (cervical spine) compression (N)	693	1,100	1,328	1,241	1,970	2,379	2,520	4,000	4,830

Revision: E	Document No: CxP 70024
Release Date: 11/19/10	Page: 496 of 503
Title: Constellation Program Human-Systems Integration Requirements	

(non-deconditioned)									
Peak neck (cervical spine) shear force (N) (deconditioned) ξ	593	946	1,142	919	1,462	1,766	1,680	2,666	3,219
Peak neck (cervical spine) shear force (N) (non-deconditioned)	690	1,100	1,328	1,069	1,700	2,053	1,953	3,100	3,743
Lumbar resultant force (deconditioned) ξ	<TBD-70024-005>								
Lumbar resultant force (non-deconditioned)	<TBD-70024-005>								
Peak Femur Axial Compression (N) (deconditioned) ϕ	1,914	3,000	3,690	2,498	3,801	5,013	3,862	5,670	8,100
Peak Femur Axial Compression (N) (non-deconditioned)	2,552	4,000	4,920	3,331	5,068	6,684	5,150	7,560	10,800
Peak Tibial Axial Compression (N) (deconditioned) ϕ	1,914	3,000	3,690	2,490	3,900	4,800	3,825	6,000	7,380
Peak Tibial Axial Compression (N) (non-deconditioned)	2,552	4,000	4,920	3,320	5,200	6,400	5,100	8,000	9,840

Revision: E	Document No: CxP 70024
Release Date: 11/19/10	Page: 497 of 503
Title: Constellation Program Human-Systems Integration Requirements	

NOTE: The values in Appendix N, tables Head Acceleration Limits, Neck Protection Criteria, and Transient Force Application Limits have been multiplied by the following scaling factors for non-launch abort landings (deconditioned crew):

ϕ - deconditioned crew coefficient for femur and tibia = 0.75
 ξ - deconditioned crew coefficient for spinal elements = 0.86
Derivation of these scaling factors is outlined in section N4.1.

NOTE: Table values were derived based on a review of the following : MIL-S-9479, USAAVSCOM TR-89-D-22A, JSSG-2010-7, SAE J885, SAE SP-731, SAE PT-47, SAE P-186, Pike (1990), SAE PT-44, Planath and Nilsson (1989), NASA-MEMO-5-19-59E, and Nahum and Melvin (2002).

TABLE N4-4 - RESTRAINED BODY MOVEMENT AND DEFLECTION <TBR-70024-001>

	0.5% risk			2% risk			5% risk		
	Small Female	50% Male	Large Male	Small Female	50% Male	Large Male	Small Female	50% Male	Large Male
Chest Sternal to Spine Deflection (mm)	28	31	35	36	44	49	41	50	55

	Lateral (+/- G _y)	Anterior (+ G _x)	Posterior (- G _x)
Head Movement (mm)	75	125	25
Chest Movement (mm)	N/A	63	25
Pelvic Movement (mm)	37	50	25
Shoulder Movement (mm)	50	N/A	N/A

Caudal Pelvic Movement (+ G _z) (mm)	50
Upward Head Movement (-G _z) (mm)	75

Revision: E	Document No: CxP 70024
Release Date: 11/19/10	Page: 498 of 503
Title: Constellation Program Human-Systems Integration Requirements	

Table values were derived based on a review of the following : MIL-S-58095A, SAE 983161, SAE SP-731, SAE-PT-43, SAE PT-44, Planath and Nilsson (1989), SFI, Inc. Specifications 16.1, 27.1, 37.1, and 39.1, AGARD AR-330, NASA-MEMO-5-19-59E, NASA-TN-D-7440, NASA-TN-D-6539, AATD Development Program Phase 1 Reports, Nahum and Melvin (2002), CFR49 Part 571, and CFR49 Part 572.

Dynamic overshoot occurs when the acceleration, forces, and moments measured on or within the human body or body segments exceed the acceleration or forces that are imparted to the human body. Dynamic overshoot is adverse only when the human body responses exceed the specified limits. The body movement limits are intended to control the amount of free space that will be permitted for body motion until the accelerating seat/restraint system contacts the occupant. The indicators of acceptability are the Hybrid III response parameters. Measurement of the displacements may be helpful in understanding the relationship between the free space and the injury metrics, but the influence of free space on the potential for injury is a function of additional factors such as the impact acceleration, velocity change, and visco-elastic properties and breaking strength of the impacted body segments.

N4.1 DERIVATION OF DECONDITIONING FACTOR

Nominal landing limits are set for loads, deflections, etc. to keep significant injury risk at the 0.5% risk level, with additional tolerance reductions resultant from the crew being deconditioned due to long-duration space flight and due to increased body movement presumed due to the launch/entry/landing suit. Therefore, a scaling factor has been applied to the non-launch abort landing scenarios in the form of a deconditioning coefficient that adjusts for the reduced capacity of the crewmember to endure flight/landing loads. It is assumed that the crew in all launch abort landing scenarios will not be deconditioned. The added body deflections due to wearing the flight suit cannot be estimated at this time. However, the body deflection constraints defined in HS3130 will apply to both the seat and the suit system; therefore, a separate suit deflection coefficient is not required.

A deconditioning factor has been estimated, which can be used to adjust the maximum allowable loading at the femoral neck and the lumbar spine during a "hard" Orion re-entry landing. The maximum allowable skeletal loading that can be experienced by an able-bodied person (i.e., no deconditioning due to reduced gravity exposure) at the femoral neck, tibia, and lumbar spine during an Orion launch abort-landing has been estimated from terrestrial crash impact data and other sources. This deconditioning factor is a function of measured physiological changes of the human body associated with dwell time away from the earth's surface (reduced gravitational environment). The data for the deconditioned crewmembers were derived from Bone Mineral Density (BMD) measurements by Dual-Energy X-ray Absorbance (DXA), as well as by Quantitative Computerized Tomography (QCT), which can provide volumetric BMD changes in the trabecular bone compartment over a mission.

The deconditioning factor can be multiplied by the able-bodied loading estimates in order to account for the BMD loss that occurs in space. For purposes of this analysis,

Revision: E	Document No: CxP 70024
Release Date: 11/19/10	Page: 499 of 503
Title: Constellation Program Human-Systems Integration Requirements	

the deconditioning factor was assumed to be a proportionality factor relating the allowable pre-flight skeletal loading to the allowable post-flight skeletal loading after deconditioned BMD loss. It was further assumed that the same probability of injury should exist in both pre-flight and post-flight cases. It should be noted that the highest likelihood off-nominal landing scenarios were drivers for establishing the following loading conditions: 1) axial compressive loading of the spine in a seated astronaut, 2) axial tibial compressive forces occurring during a seat stroke or crush in which the foot pan for a seated astronaut is pushed in the cephalic direction relative to the trunk, 3) hip loading due to a pure lateral blow to the greater trochanter of a seated astronaut, and 4) hip loading due to a blow to the kneecap of a seated astronaut.

Based on these scenarios, the deconditioning factor was calculated from changes in BMD that occur over a typical long-duration mission (~6 months); however, due to the limited range of mission durations for the data, this deconditioning factor is more appropriate for missions no greater than 6 months.

The first method for determining the deconditioning factor employed the FRAX fracture risk prediction tool to arrive at the deconditioning coefficient. FRAX is a fracture prediction algorithm developed by the World Health Organization Collaborating Center for Metabolic Bone Diseases to determine a patient's absolute probability of fracture over 10 years given specific age, gender, race, and clinical profiles. The deconditioning factor was calculated as the ratio of those two values assuming that the instantaneous bone strength at both pre- and post-flight periods is proportional to the 10-year probability of risk estimated by FRAX. The values for the coefficient for long bones and spine are set at the 2 standard deviations around the mean estimated values of the 29 long-duration flight crew who were evaluated for this purpose. Based on this analysis approach the deconditioning factor was estimated as 0.75 and 0.88 for the femur/femoral neck and lumbar spine, respectively.

Estimates of the deconditioning factor were independently calculated using a second method: an Integrated Medical Model - Bone Fracture Risk Module (BFxRM). The BFxRM estimates the probability of fracture through implementation of a statistically-based analysis that tests for results under specified ranges of the contributing parameters. This approach yields a likelihood of fracture risk for specified mission scenarios in terms of a probability density function, as well as a sensitivity analysis for the key factors underlying the risk.

Assuming that for an individual the function relating Fracture Risk Index (FRI) to probability of fracture does not substantially change due to space flight induced deconditioning, an individual's deconditioning factor (Θ) is found by setting the pre-flight FRI equal to the post-flight FRI:

Revision: E	Document No: CxP 70024
Release Date: 11/19/10	Page: 500 of 503
Title: Constellation Program Human-Systems Integration Requirements	

$$FRI(pre) = FRI(post)$$

$$\frac{Skeletal_Loading(pre)}{Max_Bone_Strength(pre)} = \frac{\Theta Skeletal_Loading(pre)}{Max_Bone_Strength(post)}$$

$$\Theta = \frac{Max_Bone_Strength(post)}{Max_Bone_Strength(pre)}$$

A relationship between the maximum bone strength and BMD was used to find the ratio, Θ , for each of the supplied pre- and post-flight astronaut BMD data. To be consistent with the FRAX-based analysis, the final values of the deconditioning coefficient were defined as the mean minus two standard deviations based on pre- and post-flight data from 29 long-duration crewmembers.

There is uncertainty in the bone strength vs. BMD relationship, as well as in the rate and magnitude of loss within the astronaut population, so a Monte Carlo simulation was performed to obtain a probability density function for Φ , including the mean deconditioning factor and the 95th percentile confidence interval. It should be noted Φ that takes into account the long-duration astronaut's variability in pre- and post-flight BMD; the Monte Carlo simulation was performed to capture the uncertainty in the relative change in bone strength that accompanies the loss of BMD.

Simulations were performed for two locations based on data provided to the GRC analysis team. The first location assumes a compressive load to the femur that results in a possible fracture at a deconditioned femoral neck. The second location assumes a compressive load applied to the lumbar vertebrae (L1-L5), resulting in a vertebral fracture at one of the deconditioned vertebrae.

A table summarizing the resulting deconditioning factors and the resulting histograms from the Monte Carlo simulations for the femoral neck and the lumbar spine are below.

TABLE N4.1-1 - DECONDITIONING FACTORS

$\Phi = mean(\Theta) - 2 * stdev(\Theta)$			
Deconditioning factor			
Mean	5 th Percentile	95 th Percentile	Skeletal Location
0.824	0.804	0.839	Femoral Neck
0.856	0.848	0.864	Lumbar Spine

An independent estimate of the deconditioning factor for long-duration astronauts has been calculated. The values estimated for mean Φ compare well with the corresponding mean population values estimated using the FRAX model (0.75 vs. 0.82

Revision: E	Document No: CxP 70024
Release Date: 11/19/10	Page: 501 of 503
Title: Constellation Program Human-Systems Integration Requirements	

and 0.88 vs. 0.86 for the femur and lumbar spine, respectively) for the same generic scenario conditions and long-duration astronaut data set. Any differences are likely due to how probabilities are calculated and used in the FRAX model and in the BFRM analysis. The 90th percentile range calculated for Φ provides the decision maker with an understanding of how the variation in and the current lack of knowledge with regard to the correlation of BMD and bone fracture strength contributes to the analysis at specific skeletal locations.

Notably, the independently-calculated deconditioning factors, albeit similar, are only as valid as the very data with which the factors are derived. These skeletal data are limited not only in total number of data points and in the range of spaceflight exposure, but also in the skeletal parameters used to evaluate bone strength. It is well recognized that a complete assessment of bone strength entails supplementing bone mineral density with measures of "bone quality." The inability to provide a measure of trabecular microarchitecture (an indirect assessment of bone quality) is a considerable limitation to the precision of the deconditioning factor calculation, particularly for the spine, which has a large component of trabecular bone. Thus, due to inability of the DXA measurement of BMD to determine the potential loss of bone strength and therefore fracture probability, due to putative changes in trabecular bone microarchitecture, there is uncertainty in the actual in- and post-flight fracture risk associated with prolonged crew reduced gravity dwell periods. This deconditioning factor will be updated as additional data regarding fracture risk associated with quantitative computerized tomography (QCT) and other imaging or research become available.

Measurements of muscular strength parameters as measured pre- and post-flight via isokinetic dynamometry were also included in determining the deconditioning effect of short- and long-duration spaceflight, as muscular strength degradation can increase the risk of limb joint structural element injury, especially in ligament and cartilaginous components around a joint.

Other considerations in the evaluation of crew deconditioning included in- and post-flight cardiovascular fitness and neurovestibular status. Changes in neurovestibular function due to prolonged spaceflight that have a consistent and persistent effect on motor coordination, the loss of muscle tissue (including degeneration of motor effector neurons), and the otolith input to the central nervous system are now believed to have a modulating effect on cardiovascular function. Furthermore, relatively low amplitude impact forces can induce Minor Traumatic Brain Injury (MTBI). The primary injury to the brain in MTBI is the result of direct acceleration impact on the head or neck. Injury can include, but is not limited to, alterations in cerebral blood flow, axonal injury (the tearing and stretching of brain tissue including damage to the cranial nerves), vestibular damage through shearing and tearing of the 8th cranial nerve, and dislodgement of both utricular and saccular otoconia. However, there is no direct evidence that spaceflight itself induces additional landing-associated CNS injury risk. Yet even in the absence of TMBI, neurovestibular status can play a significant role in landing and affect manual task performance during re-entry and vehicular egress after landing.

Revision: E	Document No: CxP 70024
Release Date: 11/19/10	Page: 502 of 503
Title: Constellation Program Human-Systems Integration Requirements	

Because cardiac rhythm changes were observed during Apollo landing tests and lunar surface operations, it is possible that cardiac performance degradation could affect tolerance to landing loads. From observations of crewmembers on the ISS, although cardiac arrhythmias have been detected, there has been no clear evidence that any cardiac arrhythmias have been induced by the mere presence of crewmembers in the space environment. Also, ISS observations have shown that initial FD30 measured declines in cardiovascular fitness (e.g., calculated VO_2 maximum) have generally recovered by FD60 with employment of in-flight exercise countermeasures and have been able to be maintained throughout the in-flight period if the countermeasures are continued.

Therefore, the following deconditioning factors, mainly driven by spaceflight-induced musculoskeletal changes, have been applied to the values in Appendix N, tables, Head Acceleration Limits, Neck Protection Criteria, and Transient Force Applications Limits as noted below.

Φ - deconditioned crew coefficient for femur and tibia = 0.75

ξ - deconditioned crew coefficient for spinal elements and head = 0.86

N5.0 Application of Occupant Protection Principles

The following are examples of industry application of restraint principles:

- 1) The body may be restrained to maintain accelerations and loads to within the limits of the human body.
- 2) The torso may be restrained with a multiple attach point harness.
- 3) The body may be supported with a conformal seat that is essentially rigid and closely fits the contours of the back and bottom of the torso, shoulders, pelvis, and legs.
- 4) The sides of the head, shoulders, hips, and legs may be supported against side impact movement with close fitting, conformal surfaces if required to maintain loads within the limits of human tolerance.
- 5) The head and neck are supported such that loads and accelerations are within the limits of human tolerance.

Effective torso restraint in automobile racing (NASCAR, IRL) and in space vehicle landing (Soyuz TM, TMA) has been accomplished with seats that fit closely to the back and sides of the crewmember to provide continuous support for the pelvis, lumbar, and thoracic spine and helmeted head. Such a seat conforms to the shape of the back and is sufficiently stiff to support the back shape and spine during crash accelerations; that is, the back of this seat is "conformal" to the body.

Revision: E	Document No: CxP 70024
Release Date: 11/19/10	Page: 503 of 503
Title: Constellation Program Human-Systems Integration Requirements	

Effective racing seats also provide lateral support for sides of the pelvis, shoulders, and head. In the past, racing seats have commonly provided close fitting lateral support of the pelvis, but such seats provided no control of motion for the upper torso and head. The addition of panels that restrain the shoulders and head dramatically reduces injury potential in side impacts for automobile crashes.