

# Developmental Testing of Electric Thrust Vector Control Systems for Manned Launch Vehicle Applications

Lisa B. Bates\* and David T. Young\*\*

## Abstract

This paper describes recent developmental testing to verify the integration of a developmental electromechanical actuator (EMA) with high rate lithium ion batteries and a cross platform extensible controller. Testing was performed at the Thrust Vector Control Research, Development and Qualification Laboratory at the NASA George C. Marshall Space Flight Center. Electric Thrust Vector Control (ETVC) systems like the EMA may significantly reduce recurring launch costs and complexity compared to heritage systems. Electric actuator mechanisms and control requirements across dissimilar platforms are also discussed with a focus on the similarities leveraged and differences overcome by the cross platform extensible common controller architecture.

## Introduction

The potential for ETVC systems to significantly reduce recurring launch costs, complexity, weight and volume, compared to electro-hydraulic systems of equivalent performance and reliability, soon may be realized on large launch vehicles for human space flight. ETVC systems have been used in the Apollo and Space Shuttle programs in the past. But conditions unique to the launch environment have up to now restricted their use for manned spaceflight to less powerful in-space applications. The lack of a suitable electrical power source and approved human rated power electronics that could be qualified to the launch environment, as well as the susceptibility of high voltage electrical power systems to corona discharge, have placed severe limitations on the power of these early manned systems.

Renewed interest in ETVC systems for high power launch vehicle applications is due to advances in key enabling technologies related to the source and control of electrical power. High rate lithium ion batteries, high-voltage, high-current insulated gate bipolar transistors (IGBT) and Field Programmable Gate Arrays (FPGA) are among the maturing technologies incorporated into the cross platform extensible controller architecture of the ETVC system tested and described in this report. The controller, battery modules and the integrated ETVC system based on a developmental EMA are the result of an internal research and development effort by Alliant Tech Systems, Aerospace Systems Group and Moog Inc., Space and Defense Group. Testing was performed in cooperation with NASA George C. Marshall Space Flight Center at its Thrust Vector Control Research, Development and Qualification Laboratory.

Among these maturing technologies, high power switching electronics such as the IGBT in particular has made it possible to further simplify actuator mechanisms and eliminate certain mechanical failure modes. IGBTs have been used extensively in the electric vehicle industry, not only to create the inverter circuits needed to power 3-phase Brushless Direct Current (BLDC) motors, but also as a key component in regenerative braking circuitry. How these technologies can reduce the mechanical complexity of an ETVC actuator will be seen in a comparison of the developmental EMA actuator mechanism with that of Apollo and Space Shuttle EMA.

The work presented in this report represents one phase in an ongoing development program aimed at demonstrating the maturity of high power ETVC systems and components for manned launch vehicle applications. The next phase of this effort will be to update a multi-channel electro-hydrostatic actuator (EHA) by adapting it to the common controller architecture while again utilizing advanced lithium ion batteries as its power source. In preparation, testing of the EHA in its present form was also carried out to baseline its performance.

---

\* NASA George C. Marshall Space Flight Center / Huntsville, AL

\*\* Raytheon – Jacobs ESTS Group / George C. Marshall Space Flight Center / Huntsville, AL

### Objectives of the Experiment

The primary goals of this experiment were to verify integration of the ETVC developmental hardware and to demonstrate functionality of the complete system. Flight specific performance requirements were not set. Moreover, this test was carried out with fewer battery modules than would be needed to achieve the full power capability of the actuator. As such, the system under test was considered to be underpowered and it was necessary to design control parameters accordingly so that peak power demands under the applied load would not exceed the capabilities of the available battery modules. Performance measurements are, therefore, meant more to indicate general functionality of a representative class of Thrust Vector Control (TVC) system, rather than in meeting a particular vehicle requirement.

Key test objectives:

- Functional integration of ETVC components
- Controller parameters tuned “in the field”
- Peak power draw and voltage droop controlled to acceptable levels
- Step and frequency response as expected for underpowered performance
- Battery cell temperatures stay near ambient
- Repeated operation on a single battery charge

For the functional demonstration, dynamic loads due to inertia and spring forces were supplied by two large Inertial Load Simulators (ILS) located at the Marshall Thrust Vector Control Research and Development and Qualification Laboratory.

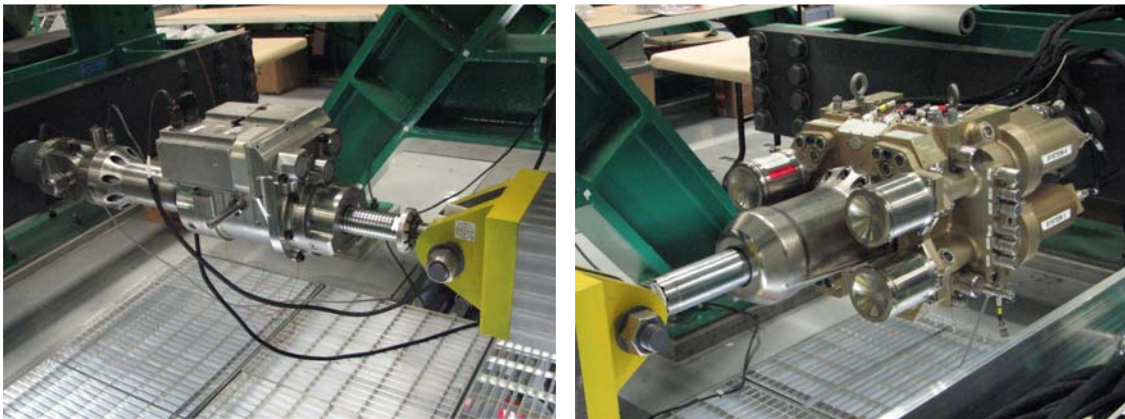

**Figure 1. Electromechanical (left) and Electro-Hydrostatic (right) Actuators**

In addition to the dual channel developmental EMA shown in Figure 1, tests were performed with the four-channel EHA also shown, to baseline its performance. This report presents data and the results of analysis for only the EMA.

### **Background**

Control of a launch vehicle during ascent implies the ability to direct the vector of the thrust that it produces. Typically a pair of linear actuators, positioned so as to rotate an engine or nozzle about its bearing along orthogonal planes, act together to define a resultant thrust vector. High inertial load and the requirement to operate from sea level to near orbital altitude are characteristics of launch vehicle applications. This is in contrast to the low load, vacuum conditions of in-space applications. High powered TVC systems are needed to react against the inertia of an engine or nozzle, as well as against the stiffness of an engine gimbal or flex bearing, vehicle structure and propellant flex lines, at the slew rates necessary to maintain stable control of the vehicle throughout all phases of flight.

### Heritage Electro-Hydraulic Actuation

Historically, high power demands could be met only by hydraulic systems. One means by which these systems could derive enormous amounts of hydraulic power was by accessing a pressurized propellant line in a liquid fueled rocket engine, such as in kerosene-based engines, at the cost of a slight performance loss to the engine. However, not all rocket propulsion systems are compatible with this approach. Therefore, auxiliary power generated by hydraulic turbo pumps and dedicated propellant systems have also been used in heritage hydraulic systems.

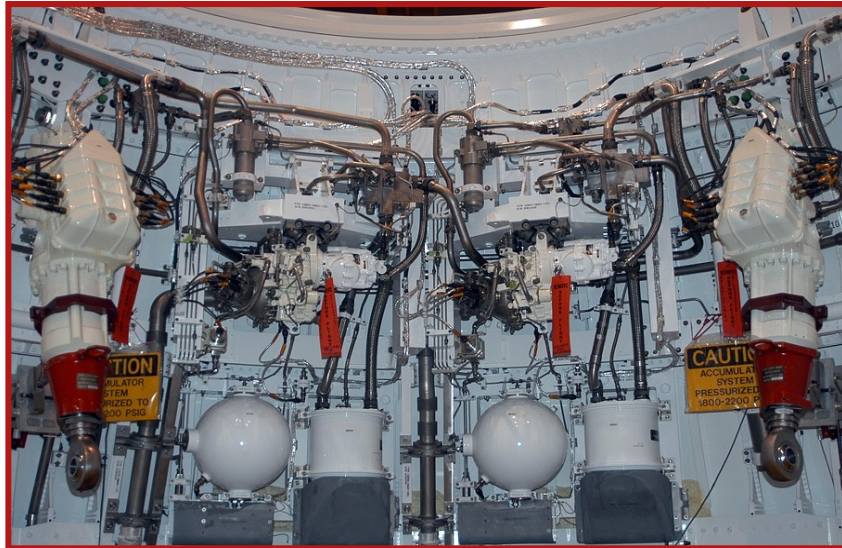

**Figure 2. Heritage TVC System**

The complex arrangement of discrete hydraulic components, seen in Figure 2 for the Space Shuttle Solid Rocket Booster, was typical of high power heritage TVC systems. It was common for such systems to have a long and elaborate process flow associated with their assembly. A major detractor that opponents of this particular approach often cite is that in order to drive the turbo pumps that generate the needed hydraulic power, these systems typically relied on the decomposition of toxic monopropellants such as hydrazine, a known carcinogen with costly storage, handling and safety concerns.

To deal with concerns about toxic monopropellants one could simply replace the heritage turbo pump with a fixed speed electric motor driven variable displacement pump, while leaving the rest of the heritage system unchanged. The trade in this case would likely be a slight increase in system mass and volume due to the lower energy and power densities of electrical power sources compared to that of monopropellant powered hydraulic turbo pumps. Another way to deal with these concerns would be to retain the turbo pump but substitute a less toxic monopropellant with equal performance, such as an ammonium dinitramide based liquid monopropellant. However, in either case, leaving the rest of the heritage system unchanged means that the complex assembly of the discrete components of the overall system still remains a labor intensive process.

While there are certain benefits that may favor heritage electro-hydraulic systems in a trade of alternate TVC approaches, these are likely to be only in the short term. As available stores of heritage hardware dwindle and mature enabling technologies continue to further advance high power ETVC capabilities, these perceived benefits will inevitably diminish.

### ETVC Systems

There are a variety of possible ETVC systems available based on the type of actuator and source of electrical power. But, in general, their inherent simplicity, compared to heritage systems, means that they can be expected to have lower operating costs because of simpler, less hazardous ground operations. The potential for less overall system weight and volume is also a possibility, in spite of the fact that electrical sources are not as power dense because of the many discrete heritage system components that can be eliminated. For example, a complete ETVC system like the EMA system tested and described

in this report, or a similar one based on the mentioned EHA, would consist of only a pair of actuators along with a set of controller boxes and a bank of battery modules such as those shown in Figure 3.

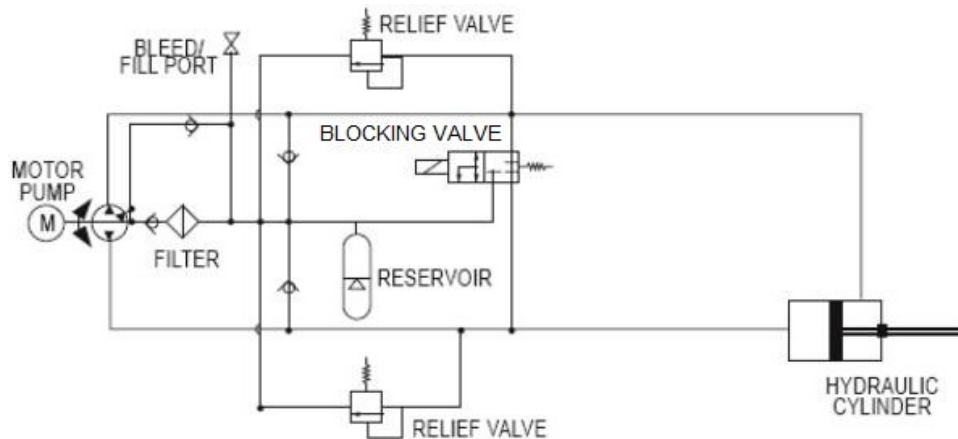

**Figure 3. Lithium Ion Battery Module (left) and Controller**

The simplicity of the EMA and EHA systems and the streamlining of ground operations that they afford is a feature shared by another type of ETVC system, the Integrated Actuator Package (IAP). The best way to think of an IAP is as an entire electro-hydraulic system self contained within each actuator. The IAP takes advantage of the approach mentioned earlier of using a fixed speed electric motor and a variable displacement pump to generate hydraulic power. This strategy, partly because it does not have to deal with propellants or turbine exhaust, allows the IAP to more readily integrate each of the components of a conventional electro-hydraulic system into a self-contained package. Like the heritage electro-hydraulic system, servo valves are used to continuously interpret low power electric command current, measured in milliamps, and, thus, regulate hydraulic power to either side of the actuator main piston. In this way, the IAP is very similar to the EHA.

#### Electro-Hydrostatic Actuation

The electro-hydrostatic actuator is another approach available for ETVC systems that possesses both electrical and hydraulic power system attributes. Unlike purely hydraulic TVC systems, EHA systems rely on an electric motor driven positive displacement pump, incorporated into the body of the actuator, to generate hydraulic power and meter fluid to and from a hydraulic cylinder. Like the IAP, all hydraulic components including the fluid reservoir, manifold, filters, etc. are incorporated into the body of the actuator, simplifying system integration and reducing the total volume of hydraulic fluid used in the overall system. The difference between these self contained systems is in the type of pump used and in the way position commands are interpreted, which for the IAP involves servo valves.



**Figure 4. EHA System Elements**

The schematic in Figure 4 shows the system elements of a typical EHA system and can be used to understand its operation. Position commands interpreted by a controller (not shown) are used to continuously update speed and direction of a reversible, variable speed, 3-phase BLDC motor. This motor drives a fixed displacement pump creating a hydrostatic pressure difference across the hydraulic cylinder. The fixed area of the cylinder piston translates this pressure difference into a force proportional to the speed of the motor which acts against the applied load. Finally, position and velocity feedback (not

shown) is used by the controller to close the control loop on the commanded position. The EHA, which was also tested, is a four channel version of this same arrangement. Each of four identical channels responds independently to what are nominally the same commands. The hydrostatic pressure developed by all four channels combines at the hydraulic cylinder to create a net total pressure and sizing is sufficient to tolerate the failure of two channels without loss of the targeted performance. The blocking valve is used to remove an errant channel from the system by equalizing its pressure contribution and pressure relief valves are provided for safety. Sizing of the reservoir, depending on the application, is either determined by peak power demands or is based on the thermal capacity of the total hydraulic volume and the mission duration.

### Electromechanical Actuation

The EMA, the simplest of all ETVC actuator types, is nothing more than a mechanism that converts electrical energy into the torque of a rotating variable speed motor and then into linear motion through a mechanical transmission. This ultimately puts energy into the motion of an engine or nozzle mass that the EMA must also be able to absorb as it brings this motion to a stop. In the case of the EMA tested, a 3 phase BLDC motor is used to both add and remove kinetic energy to the overall system. Many electric automobiles use BLDC motors and high power solid state switches to recover energy and improve mileage. But, whether recovered by the electrical power source, or simply dissipated through a resistive load, high power solid state switches such as the IGBT make it possible to handle high levels of excess kinetic energy electronically through motor torque. As a result, the mechanical brakes and clutches of older systems, with their potential for failure due to contamination and wear, are no longer necessary.

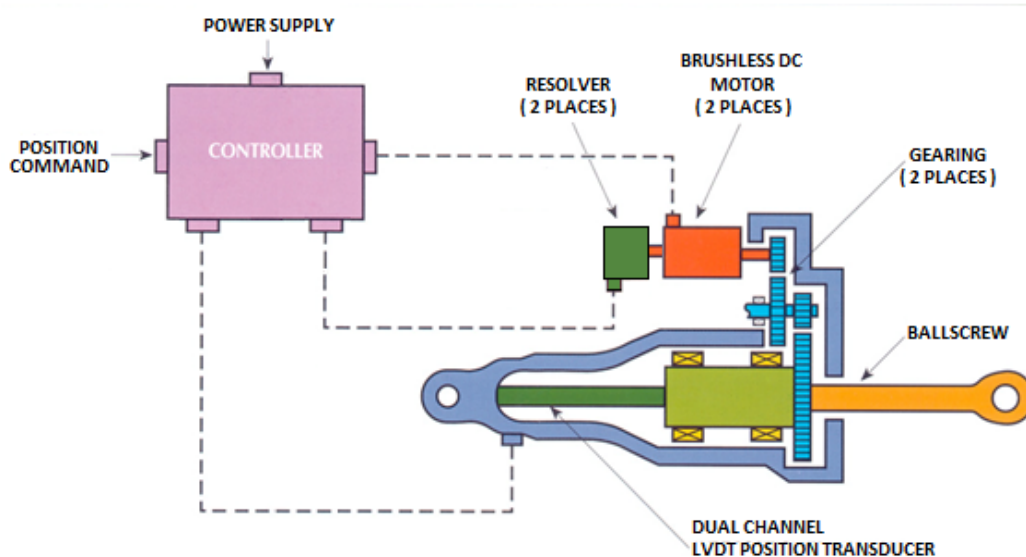

**Figure 5. Dual Channel developmental EMA and Controller**

The architecture of the EMA system that was tested allows it to be single fault tolerant, with the redundancy of two active channels. Identical position commands, which on a vehicle would come from a flight computer, are sent to a motor controller on both of its command channels and telemetry feedback from sensors within the actuator is returned. Position feedback is measured directly by a dual channel linear variable differential transformer (LVDT). On the other hand, actuator velocity, the rate of change of the actuator rod end position, is not always a direct measurement. Often it is derived from electric motor velocity, which is much faster prior to gear reduction and, therefore, offers greater resolution. Motor velocity can be monitored using a generator or similar such device. Motor position can also be acquired using a resolver or an encoder. In the case of the developmental EMA, resolvers are used for both motor position and motor velocity.

As illustrated in Figure 5, the outputs of two identical 3-phase BLDC motors are combined through spur gears to create a torque-summed moment upon a common ball screw mechanism. The ball screw is used in a rotating nut / translating screw configuration. It should be noted that because two channels are

combined at a common ball screw, mechanical redundancy is lost at this point. There are several potential failure modes that can be identified for the common ball screw. Seizure of the ball screw mechanism preventing motion of the actuator at an inopportune time can be catastrophic. For the EHA and IAP, hydraulic power transmission through a main piston cylinder virtually eliminates potential jamming concerns assumed by electromechanical transmissions. The strategy for dealing with such failure modes in the EMA that was tested is to size each motor and drive train sufficiently so as to provide adequate torque to overcome some degree of potential mechanism seizure. It has been asserted by the manufacturer that deformation of the ball or race, by this means, or through wear, as well as any potential hazard of contamination, would likely result in only degraded actuator performance, but not failure. Based on manufacturer studies, it is expected that under such degraded conditions, the ball screw would simply behave like a nominal Acme screw mechanism.

Precedence for a multichannel EMA actuator with common drive train components can be found in the first ever ETVC system developed for manned space flight. The Apollo Service Propulsion System (SPS) which was relied upon to perform its mission critical trans-lunar injection maneuver, successfully employed a mechanically similar approach for its EMA. However, the Apollo EMA differed in its redundancy scheme in that it employed an active / standby system. The Apollo SPS was located within the Service Module of the Apollo spacecraft and utilized only after the Saturn launch vehicle had carried it into orbit. Therefore, the Apollo EMA is considered to be an in-space propulsion system, and this fact likely influenced the choice of an active / standby approach.

Another example where ETVC have been effectively used in manned space flight is found in the Space Shuttle Orbital Maneuvering System (OMS). The OMS, located near the aft end of the Space Shuttle Orbiter provided thrust to perform orbit insertion, orbit circularization, orbit transfer, rendezvous and de-orbit. These were maneuvers performed after Space Shuttle Main Engine cutoff, and, for this reason, the OMS is also considered to be an in-space propulsion system.

The Apollo and Space Shuttle EMA were both two channel actuators, which nominally operated one active channel, the primary channel, while the other secondary channel was reserved as a standby in the event of primary channel failure. This differs from the developmental EMA, which nominally operates two active channels, a scheme that is considered to be more reliable because of the probability associated with the standby channel not being available when called upon, a risk more often accepted for in-space propulsion than for launch because it is not always practical to require in-space systems to be active prior to launch.

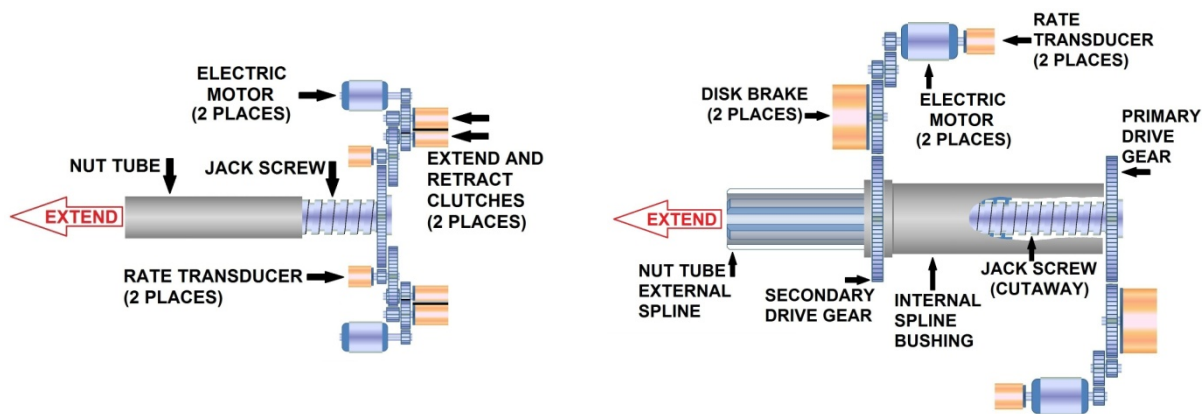

**Figure 6. Active / Standby EMA Mechanisms**

Careful consideration of the two mechanisms illustrated in Figure 6 will provide insight into some of the ways in which redundancy can be achieved by EMA systems and of their relative merits. The mechanism on the left utilizes two clutches with each motor to control the direction motor torque is applied to a common jack screw through a common drive gear. Braking is achieved by applying torque opposite the direction of travel. The nut tube and the jack screw on which it translates as the jack screw turns are single point of failure components. Likewise, the common drive gear and associated shaft and bearing are single point of failure components because these components are also shared by both channels.

The mechanism on the right of Figure 6 illustrates how redundancy can be achieved throughout the entire drive train including translational motion. As seen in this illustration, the nut tube will translate along its external spline due to the rotation of the jack screw or due to the rotation of the nut tube as driven by the rotation of the internal spline bushing. Disk brakes are used in this mechanism to prevent movement of the secondary standby channel while the primary channel is active, or vice versa. Significantly, these brakes are also used to arrest movement of the active channel and, thus, dissipate energy as motion of the engine nozzle is stopped.

#### Power and Control Considerations

Technology innovation efforts such as the More Electric Aircraft initiative by the Air Force and efforts by the commercial aircraft and automotive industries have led to many new advances in power electronics and direct current power sources. For aircraft applications, a bus voltage of 270 Volts has emerged as more or less an industry standard. But, launch vehicle applications have unique considerations because of the altitudes traversed for which this voltage may be a concern. The dielectric constant of the air changes with altitude, making it easier at higher altitudes for high voltages to break down the dielectric barrier of the air in a process known as corona discharge. At still higher altitudes, susceptibility to corona discharge vanishes as the vehicle enters near vacuum conditions, which is why high voltages do not exhibit this particular concern on orbit. But, for launch vehicles this phenomenon can be potentially disruptive to sensitive electronics elsewhere on the vehicle, as well as to the TVC system itself. At sea level, thousands of volts are required to induce the onset of a corona discharge. For aircraft, a bus voltage of 270 Volts is not a corona concern because it is well below the corona onset voltage at the altitudes where most aircraft fly. Many factors influence a corona discharge event. Atmospheric pressure and constituency, bus voltage and frequency, as well as conductor geometry, are all factors that play a role. Use of a 270 Volt bus for launch vehicle applications is based partly on the belief that design and construction standards, once developed and validated, can be applied to manage this issue.

The availability of approved high voltage, high current power electronics presents another challenge to high power ETVC systems for use in human rated launch vehicle applications. An effort by NASA to update requirements and its list of suitable parts for this application is underway. Addressing this concern and that of corona discharge susceptibility is a priority for proponents wishing to gain acceptance of powerful ETVC on large manned launch vehicles.

The use of FPGA by avionics has already gained wide acceptance for manned launch vehicle applications. Within the common controller architecture FPGA, allow control parameters to be tuned to specific applications and the needs of specific actuator classes. When the testing presented in this report was performed, the developmental EMA actuator was the highest powered example to which the common controller had yet been configured. Actuator classes already covered by the common controller in previous developmental tests include: an electromechanical rotary engine control valve actuator, an electromechanical launch abort system valve actuator, and a less powerful EMA. Control of an EHA is planned as future work.

The common controller leverages a modular architecture to increase its flexibility across dissimilar actuator platforms. As seen in the discussions of EMA and EHA mechanisms, actuator types differ not only in power requirements but also in instrumentation and control schemes. In a modular architecture, signal conditioning and instrumentation drive circuitry can be swapped out as required by a particular actuator type.

### **Laboratory Demonstration of Integrated EMA System**

The integrated system test brought together all the elements of a single channel for one axis of a complete ETVC system. These system elements included the two-channel single fault tolerant developmental EMA, four high rate lithium ion battery modules and the cross platform extensible common controller. Testing was performed during August and September of 2011. It was during the first week of testing, when system integration and check out was performed, that it was necessary to modify control parameters for more optimal performance under test conditions. This modification satisfied the objective of demonstrating that control parameters were not merely factory preset constants but could be potentially changed in the field.

Developmental hardware was used for these tests rather than the more flight-like battery module and controller shown in Figure 3 because they were not available at the time these tests were performed. As can be seen in Figure 7, four developmental battery modules, each containing many individually matched cells, were combined to form a single bus.



**Figure 7. Developmental Lithium Ion Battery Supply (left) and Common Controller**

Test Setup and Procedure

The integration of the developmental EMA with the common controller and battery modules was done as illustrated by the interconnection diagram of Figure 8. In addition to the developmental hardware, this test setup also includes a Power Control and Regeneration circuit and the Universal Test Interface (UTI) needed to communicate with the common controller and translate telemetry into a form that could be recorded by laboratory data acquisition systems. Telemetry included commanded position, actuator position and force, motor current and motor velocity. The UTI and Regen circuit are Moog, Inc., Space and Defense Group proprietary hardware. The EMA, and Battery Modules used in this demonstration are NASA owned assets. The common controller is ATK and Moog jointly held proprietary hardware.

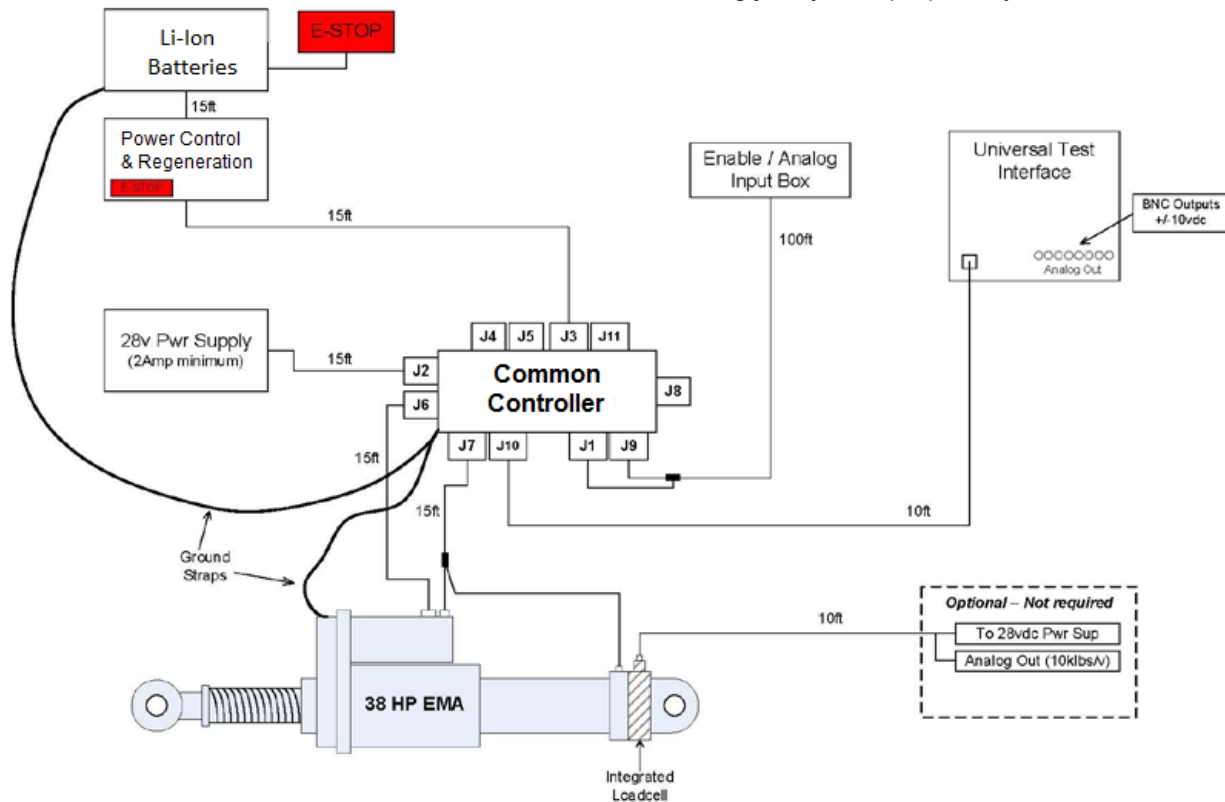
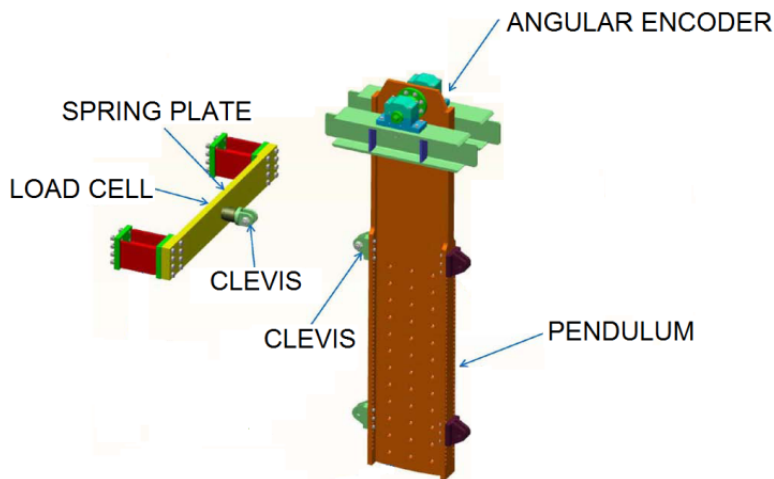

**Figure 8. EMA System Test Interconnect Diagram**



Battery cell temperatures at 38 separate locations were monitored by an Agilent model 34970A Data Acquisition / Switch Unit using Type-T thermocouples. Temperature logs were made during charging of the battery modules, as well as during testing of the integrated system. Logs would often cover several tests performed on a single day to track thermal data across consecutive runs. This also demonstrated the objective of repeated operation on a single battery charge. A voltage probe, visible in Figure 7, and a current probe applied to the Power Control and Regeneration circuit were used to verify that the integrated system was able to control peak power draw and voltage droop to acceptable levels.

One of two large single axis inertial load simulators was used to provide representative inertial and spring loads for EMA system testing. These test stands were designed by Marshall Space Flight Center (MSFC) engineering and are located at the Marshall Thrust Vector Control Research, Development and Qualification Laboratory in high bay 110 of building 4205 at the NASA Marshall Space Flight Center.



**Figure 9. Schematic of large inertial load simulator**

The developmental EMA was mounted between the two clevises indicated in Figure 9, as shown in the photograph of Figure 1. Each ILS is instrumented to measure tension and compression forces applied by an actuator using a Honeywell model 3156-150K load cell that has a capacity of 667.2 kN (150,000 lbf). Pendulum position is measured to a system accuracy of 2 arc seconds using a Heidenhain RCN 729 absolute angular encoder.

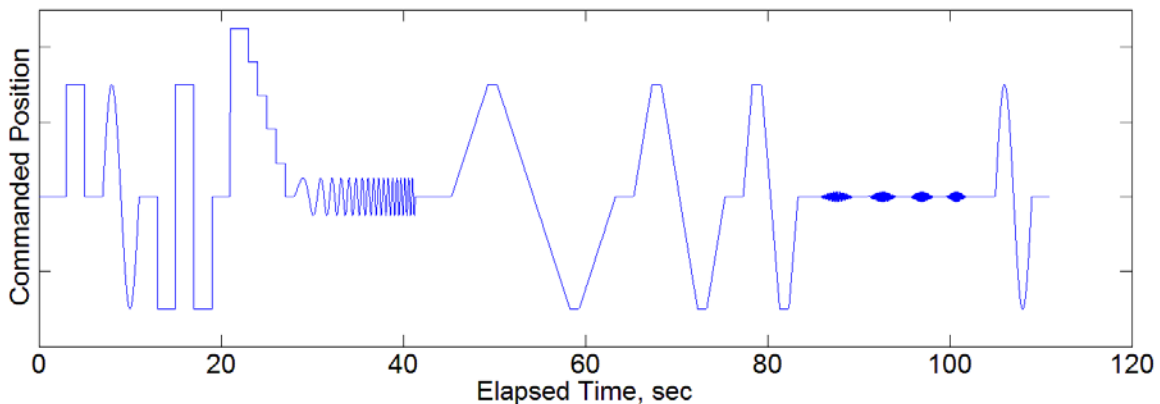

**Figure 10. ETVC Demonstration Duty Cycle**

Two programmed duty cycles were created to exercise the actuators through a series of steps, ramps, discrete frequency sine waves and frequency sweeps. The ETVC Demonstration Duty Cycle shown in Figure 10 is somewhat aggressive. Lasting 111 seconds, this duty cycle created a relatively high demand on the power source and controller during use, and as such far exceeded the demands typically placed

on TVC systems in a realistic launch scenario. The ETVC Demonstration Duty Cycle consisted of the following sequence: Large amplitude steps in the extend and retract directions; A single period of a 1 Hz sine wave at the same large amplitude; A stepwise return to null done in 5 discrete steps; A continuous sine-sweep from 1 Hz to 16 Hz, inclusively; A set of large amplitude ramps; A set of four discrete sine waves, chosen to excite a structural resonance within the test stand; Another large amplitude single period sine wave at 1 Hz. This duty cycle was used for both EMA and EHA testing.

#### Lessons Learned

For EMA testing, it was necessary to first command the actuator away from null and then to displace the duty cycle accordingly. This was done because the type of LVDT used in this particular actuator created a control discontinuity as the actuator passed through null. The preferred solution would have been to change out the LVDT for one more optimally suited. However, schedule constraints did not allow for the exchange of this LVDT, so it was decided to simply avoid duty cycles that commanded the actuator through the null position.

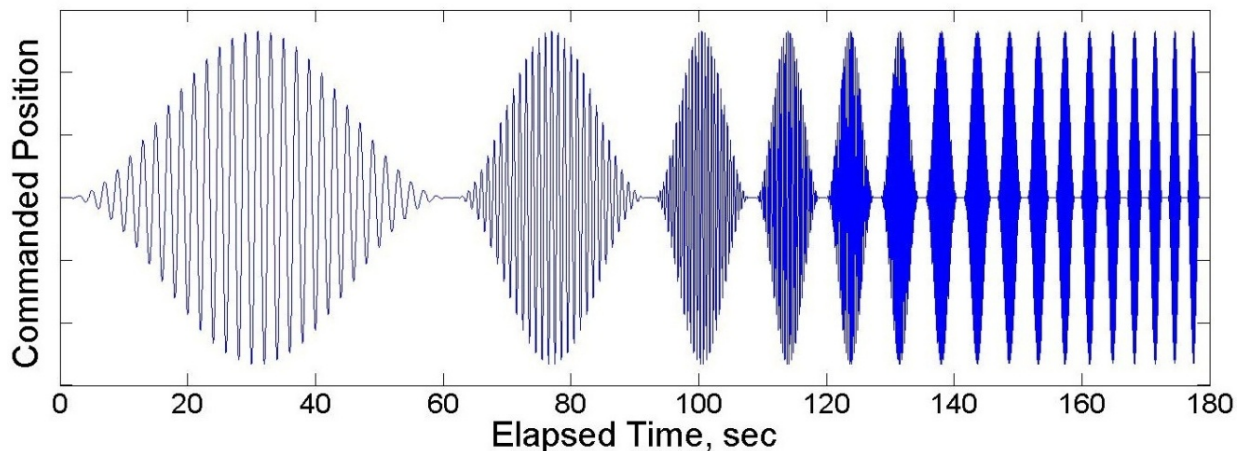

**Figure 11. Discrete Frequency Duty Cycle**

The discrete frequency response duty cycle shown in Figure 11 was the other programmed duty cycle used. It was generated to assess the frequency response of the integrated EMA TVC system. This duty cycle consisted of a set of 17 sinusoidal waveforms covering the frequencies 0.5 Hz, 1.0 Hz, 2.0 Hz, ..., 16 Hz. Unfortunately, a fixed number of 30 cycles was programmed for each frequency. The preferred method would have programmed a fixed duration for each frequency so that the number of data samples acquired would be equal. The duty cycle used resulted in a broadening of the individual spectral response curves with increasing frequency. Although this error was not identified at the time of testing, sufficient spectral data was present in the recorded command and response signals to perform the needed assessment.

To each of the 17 individual sinusoidal waveforms of the discrete frequency duty cycle a Hanning window was applied, creating a smooth, gradual rise in amplitude to a maximum followed by an equally gradual reduction of amplitude. A wait time of 1 second was introduced between each waveform. This technique was used as a result of lessons learned during a previous modal assessment in which it was observed that whenever abruptly starting and stopping sinusoidal waveforms an impulse component was introduced with its associated broadband excitation. This technique was verified by Fourier analysis to be a very effective means of applying monochromatic (single discrete frequency) excitation.

The recorded command signal and the actuator response, acquired via LVDT, were analyzed by applying a discrete Fourier transformation individually over time intervals corresponding to each successive frequency in the duty cycle. The highest four frequencies (13 Hz, 14 Hz, 15 Hz and 16 Hz) were discarded because the transform of the response did not meet the necessary criteria for inclusion. The coefficient of variation ( $CV = \sigma/\mu$ ), representing the ratio of the standard deviation to the mean of a computed discrete Fourier transform, was used as this criterion. Only those responses for which the calculated CV was greater than 1 were selected.

## Results and Conclusions

All test objectives were accomplished without any unexpected outcome. Functional integration of all developmental ETVC components was performed. Controller parameters were adjusted for smoother operation and to account for differences due to the larger inertial load at the MSFC laboratory facility compared to that at Moog facilities. This need provided an opportunity to demonstrate the ability to tune the controller “in the field”. Peak power draw and voltage droop was demonstrated to be controlled to acceptable levels as was repeated operation on a single battery charge.

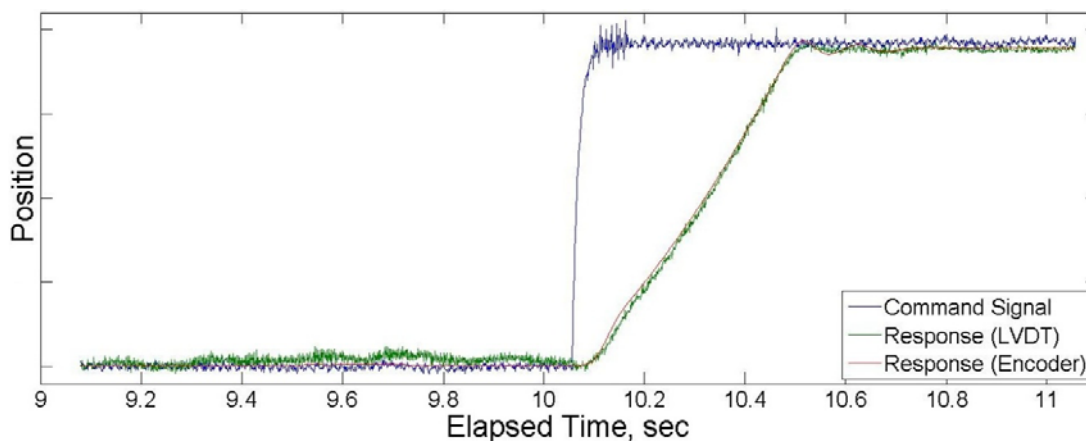

**Figure 12. Step response of EMA actuator**

The dynamic behavior of the EMA system was determined for step and frequency response. Figure 12 shows the response of the EMA actuator to a large commanded step in the extend direction under the test stand inertial load. This step occurred at the start of the aggressive ETVC Demonstration Duty Cycle. Response as recorded by the LVDT and the optical angular encoder, which provided a much cleaner signal, are plotted along with the recorded command signal.

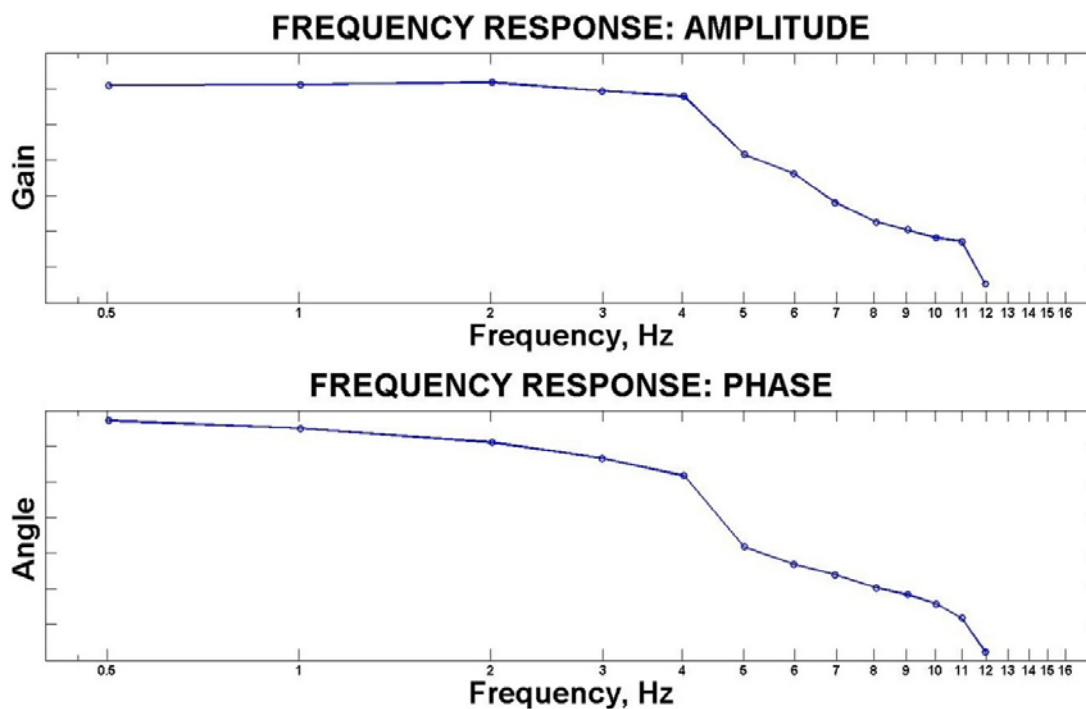

**Figure 13. Gain and Phase Spectra of Underpowered EMA**

Gain and phase response spectra of the underpowered EMA are shown in Figure 13. Poor performance above 4 Hz was expected under the inertial load and power limitations imposed by the test. Frequencies above 12 Hz were discarded because the response did not meet the acceptance criteria for inclusion. This is equivalent to the magnitude of the response being below the effective noise floor of the data acquisition system.

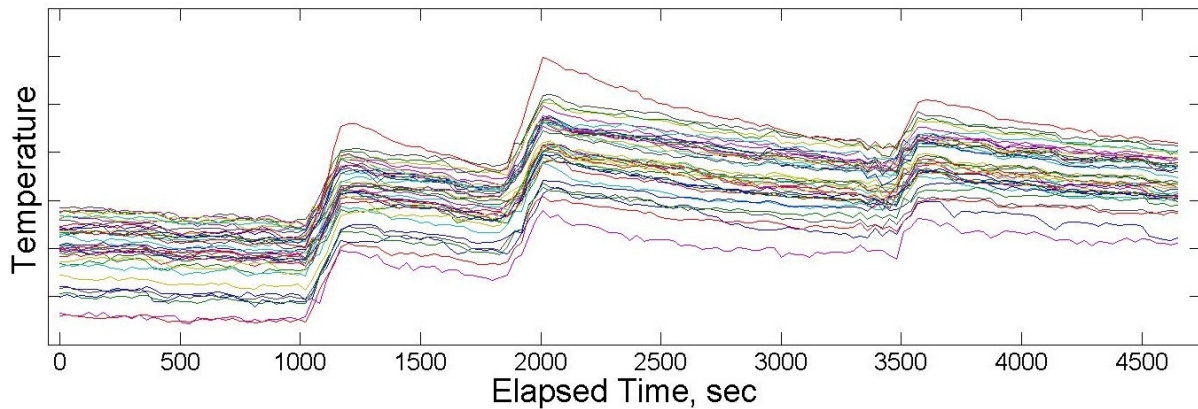

**Figure 14. Lithium Ion Battery Temperature Log (worst case)**

The highest battery cell temperature was recorded on 2 September 2011. The temperature log for that day, shown in Figure 14, captures a total of three EMA tests. A single thermocouple measured a single out of family temperature event at 2,010 seconds, elapsed from the start of the log, which corresponds to the end of the 2<sup>nd</sup> EMA test performed that day. At the same time, the temperature nearest that value, recorded by another thermocouple, was compared. The difference is not significantly greater than the standard deviation measured across all temperature data at this same time. This means that the amount by which this single value is out of family is insignificant. It should be noted that even for this worst case example, the rise in temperature was not appreciable, the temperature returned to an in family value post test and, in no case, did any cell temperature ever approach a level of concern.

### References

1. Garrison, Michael and Scott Steffan. "Two Fault Tolerant Electric Actuation Systems for Space Applications." *Association Aeronautique et Astronautique de France (AAAF) Changes in Aeronautical and Space Systems, Challenges for On-Board Energy Conference*, Avignone, France (26 - 28 June 2006).
2. Garrison, Michael and Scott Steffan. "Two Fault Tolerant Electric Actuation Systems for Space Applications." *AIAA-2006-4939, 42<sup>nd</sup> AIAA/ASME/SAE/ASEE Joint Propulsion Conference*, Sacramento, CA. (9 - 12 July 2006).
3. McMahon, William A. "Apollo Experience Report – Guidance And Control Systems: CSM Service Propulsion System Gimbal Actuators." NASA TN D-1969 (July 1975).
4. Wayne, Duke. "OMS/RCS Subsystem Presentation." NASA GNC Presentation at NASA Kennedy Space Center, (4 June 1996).
5. White, Robert A. "High Voltage Design Criteria." Marshall Standard MSFC-STD-531, George C. Marshall Space Flight Center (September 1978).
6. Dunbar, William G. "Corona Onset Voltage of Insulated and Bare Electrodes in Rarefied Air and Other Gases." Air Force Aero-Propulsion Laboratory Technical Report AFAPL-TR-65-122, Air Force Systems Command, Wright-Patterson Air Force Base (June 1966).
7. United States Environmental Protection Agency. Hydrazine Hazard Summary-Created in April 1992; Revised in January 2000.

# **Developmental Testing of Electric Thrust Vector Control Systems for Manned Launch Vehicle Applications**

**41<sup>st</sup> Aerospace Mechanisms Symposium  
Pasadena, CA May 16-18, 2012**

**Lisa B. Bates**

**NASA George C. Marshall Space Flight Center**

**David T. Young, PhD**

**Raytheon / Jacobs ESTS Group, George C. Marshall Space Flight Center**

# Electric Thrust Vector Control

## Motivation:

*To evaluate reduction in  
recurring launch costs, complexity,  
system weight and volume*

*compared to high powered  
heritage hydraulic systems of  
equivalent performance and reliability*

# Thrust Vector Control (TVC)

## Two-Axis Nozzle Rotation

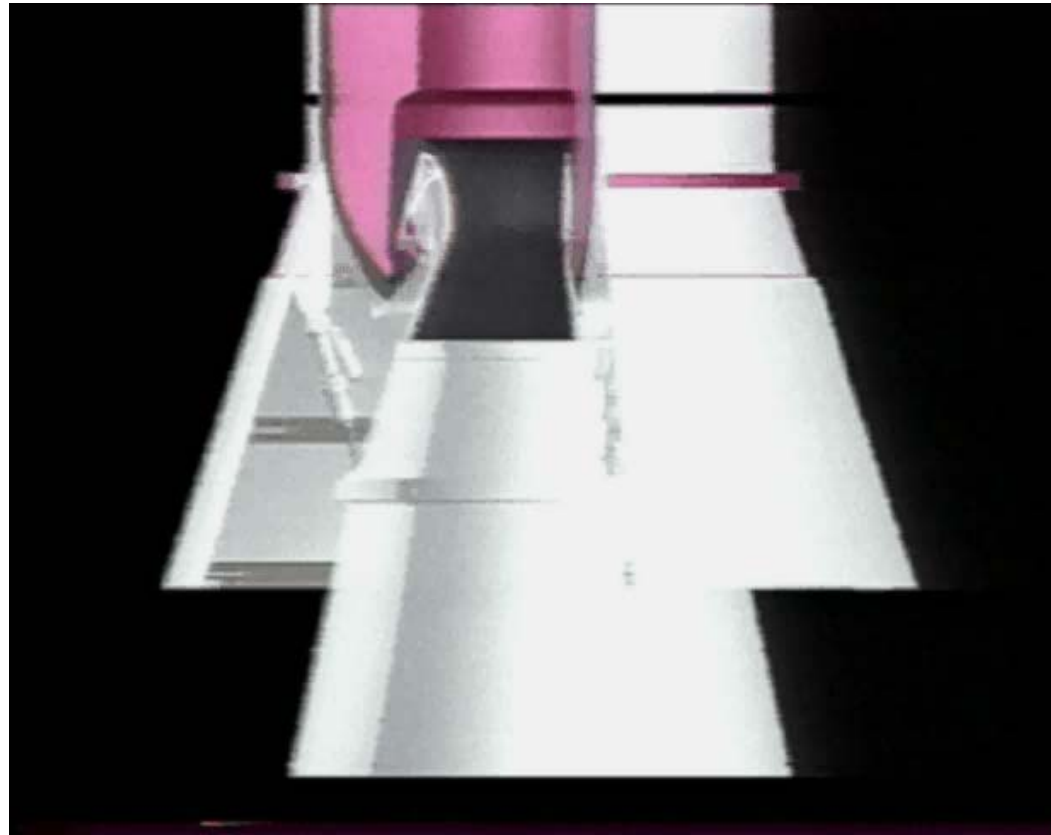

**Example: Space Shuttle Solid Rocket Booster**  
**Linear actuators rotate nozzle to create resultant vector**

# Heritage Hydraulic TVC Systems

**Centralized Hydraulic System Powered by Decomposition of Hydrazine Fuel**

**High Operational Cost**

- Large Component Count
- Labor-Intensive Manual Assembly
- Safety & Environmental Concerns

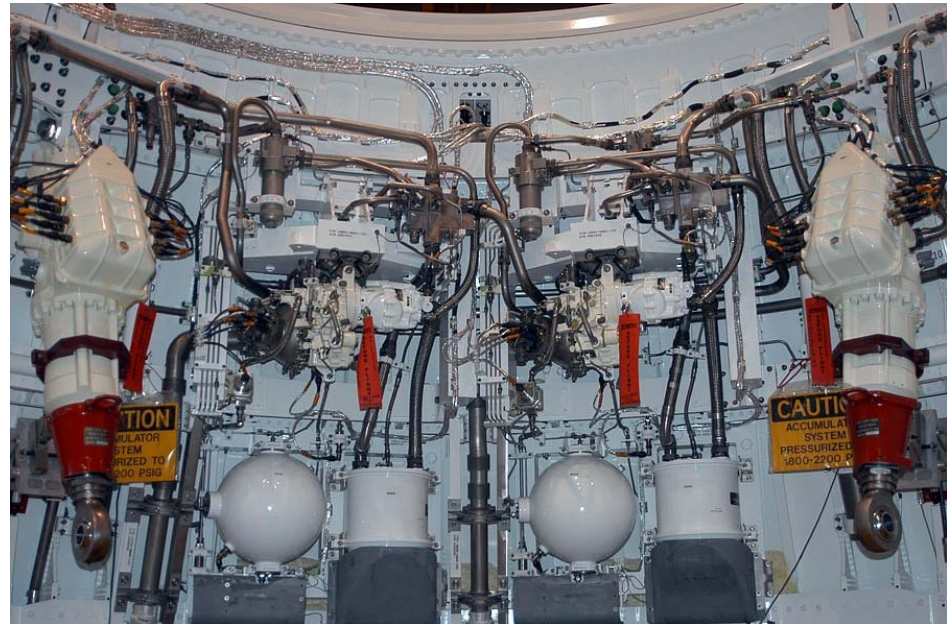



# Electric TVC Systems (ETVC)

## Simplified Architecture

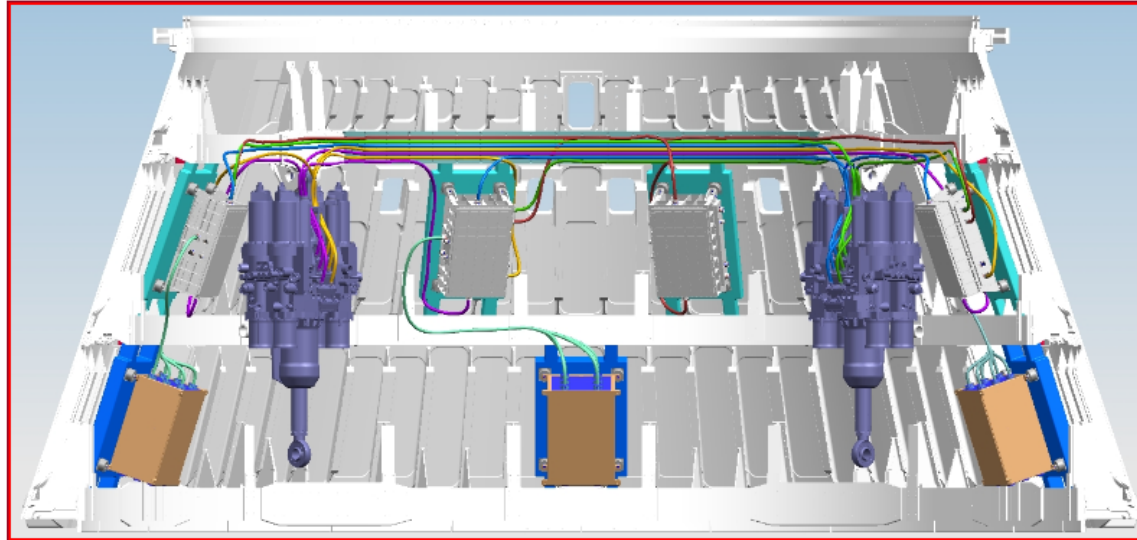

**Battery Powered**  
**Common Controller**  
**Lower Operational Cost**



# Forms of ETVC

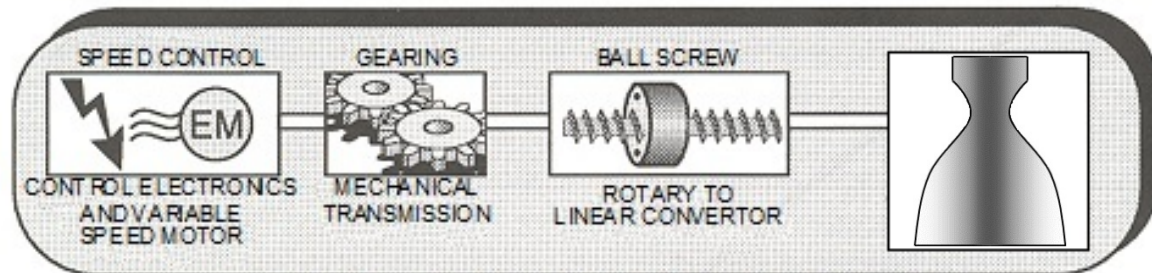

**ELECTROMECHANICAL ACTUATOR (EMA)**

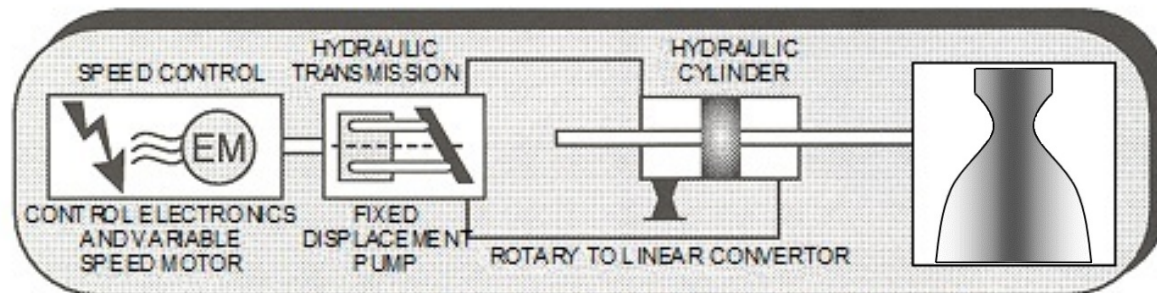

**ELECTRO-HYDROSTATIC ACTUATOR (EHA)**

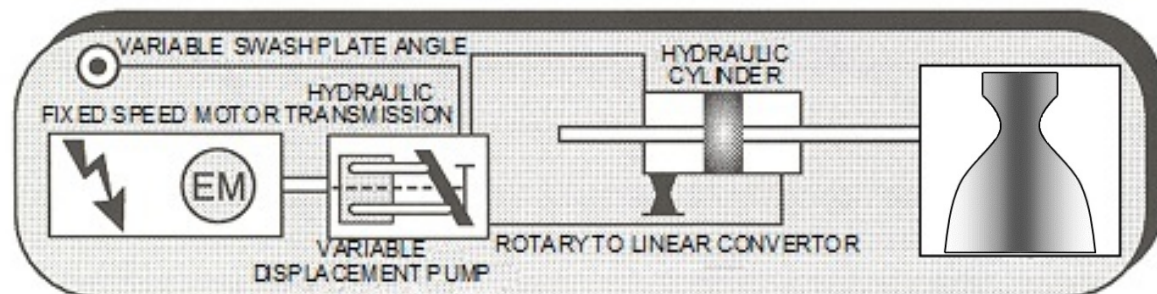

**INTEGRATED ACTUATOR PACKAGE (IAP)**

# Potential Advantages

## EMA Advantages

- **Long-term storability (shelf life)**
- **Easy system check-out & health monitoring**
- **Simple installation**
- **No hydraulic fluid contamination concerns**
- **No hydraulic fluid leakage**
- **No central hydraulic fluid reservoirs**
- **Self-contained Line Replaceable Unit**
- **Low quiescent power draw**
- **Lower weight than hydraulic blowdown TVC**

# Potential Advantages

## EHA Advantages

- Limited fluid contamination & leakage concerns
- Pressure is infrequently developed in response to static loads or accelerations
- Fluid locally contained in LRU, not a centralized hydraulic system
- No backlash, lost motion as with geared systems
- Heritage hydraulic piston cylinder assembly
- Self-contained hydraulic supply & return porting
- Capable of operating at high system pressures

# Potential Advantages

## IAP Advantages

- **Wide range of flow demands can be satisfied with a single integrated motor-pump assembly**
- **Low operating power draw for lower flow conditions**
- **High power-point operating efficiency**
- **Simplified power electronics**

# EMA Past & Present

## **Apollo Service Propulsion System EMA**

- Active / Standby Redundancy
- Unidirectional Motors
- Extend and Retract Clutches

## **Shuttle Orbital Maneuvering System EMA**

- Active / Standby Redundancy
- Bidirectional Motors
- Disc-Brakes

## **Developmental EMA**

- Two Active Channels
- Brushless DC Motors
- Modern Control and Power Electronics

# Service Propulsion System EMA

**Apollo**

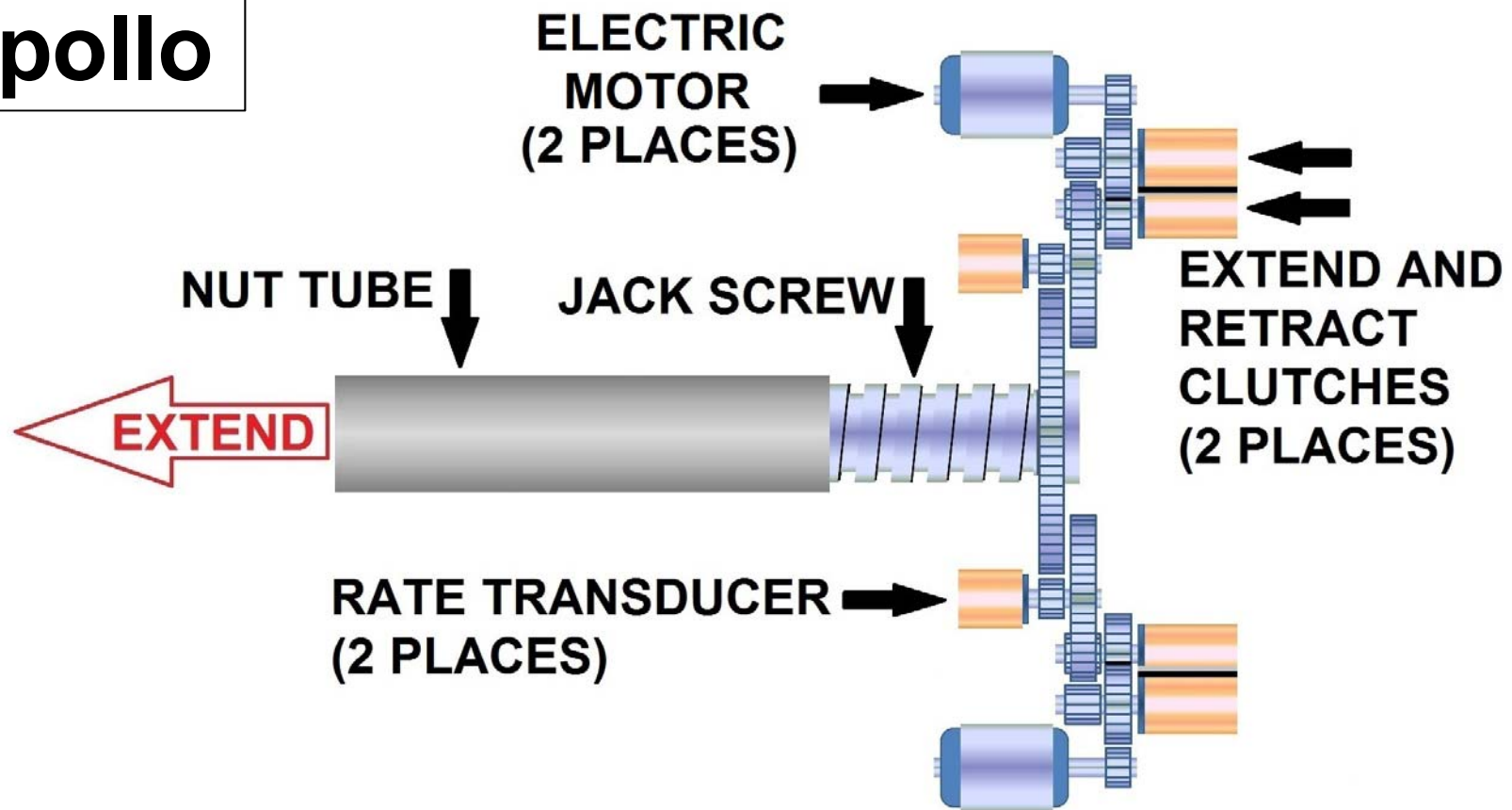

**Unidirectional Motors  
Active / Standby Redundancy**

# Orbital Maneuvering System EMA

**Shuttle**

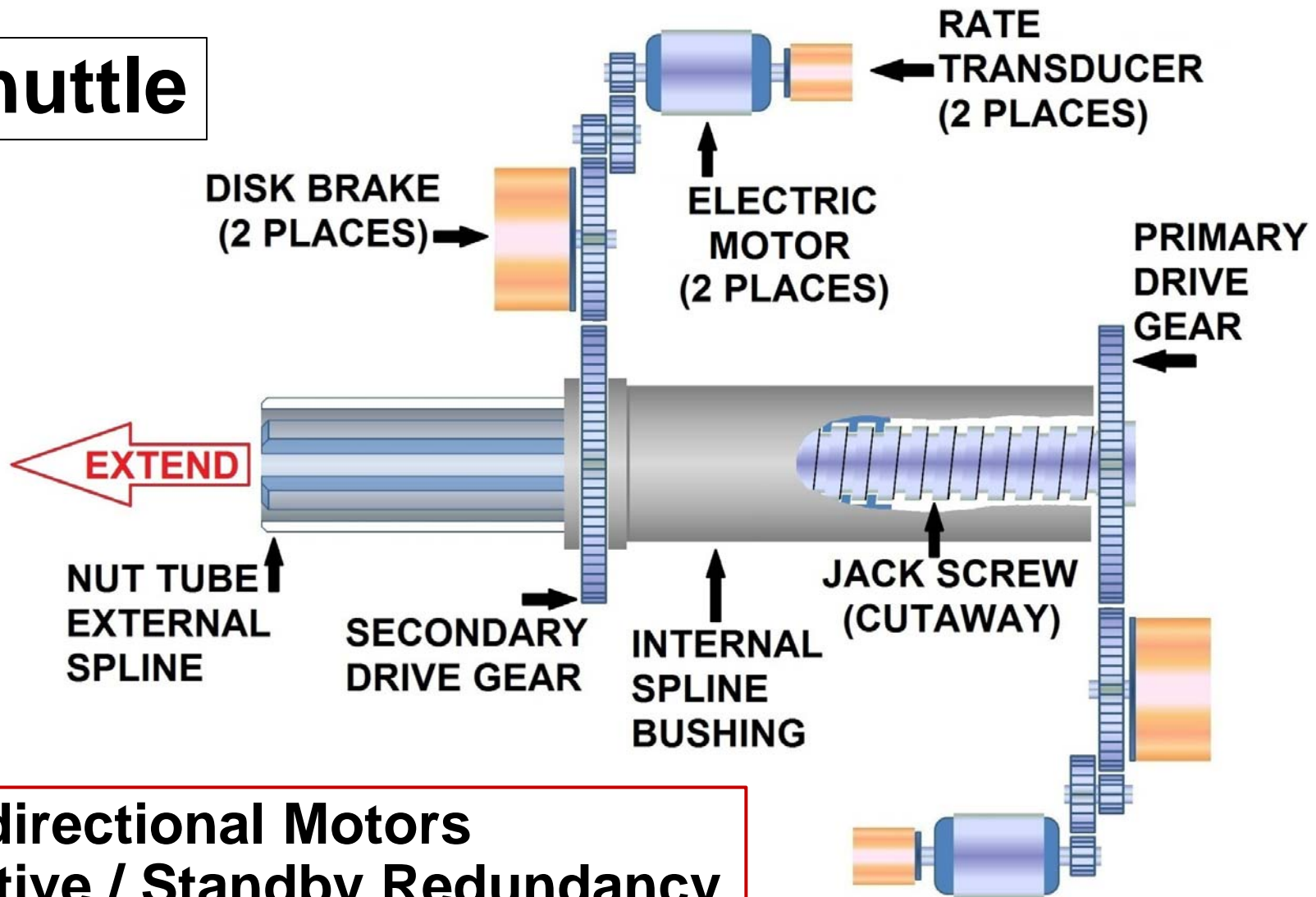

**Bidirectional Motors  
Active / Standby Redundancy**



# Developmental EMA

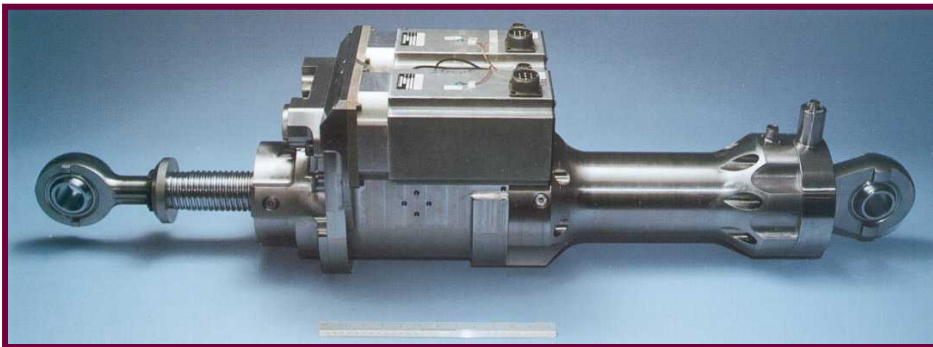
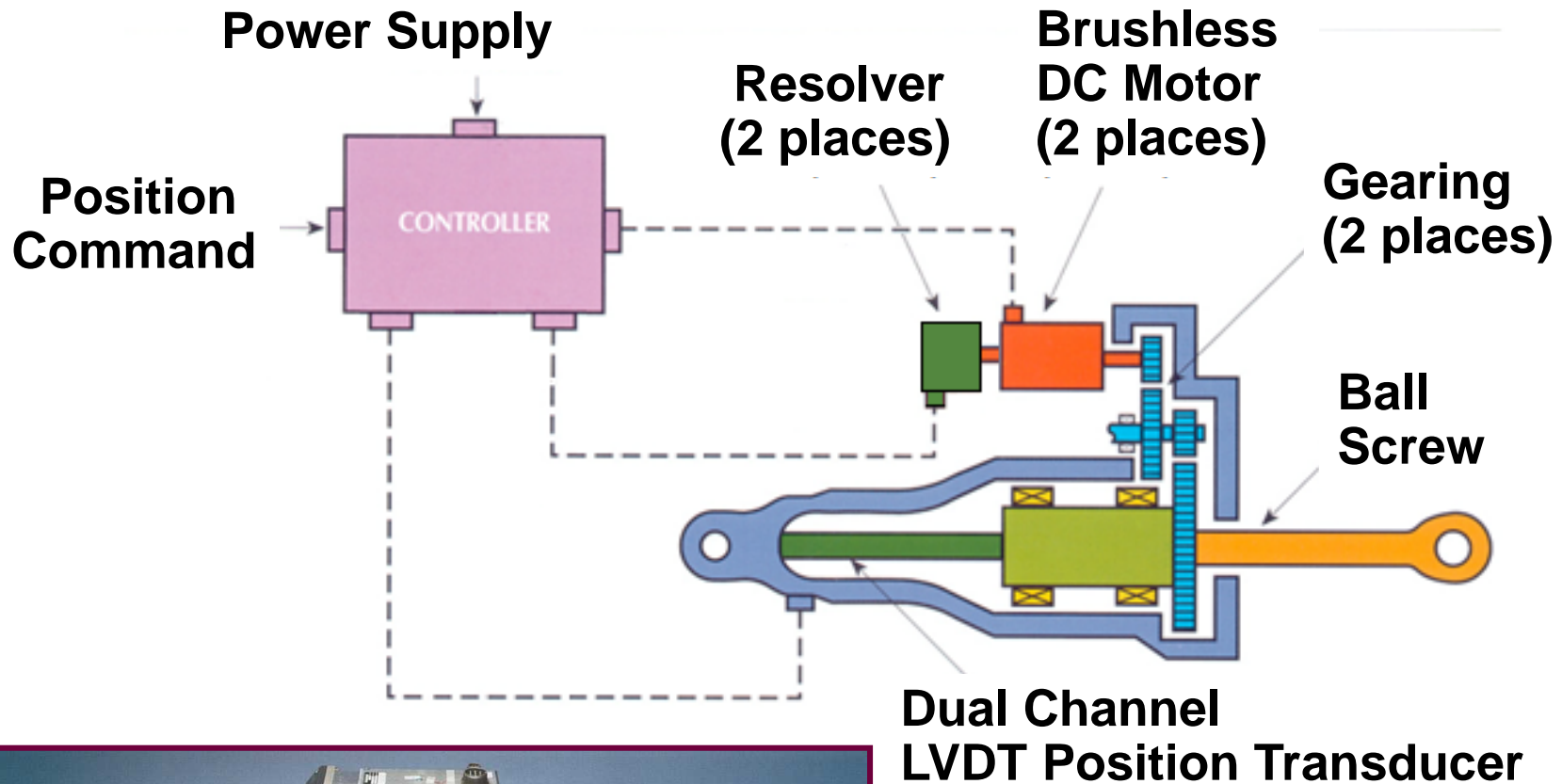

**Two Active Channels  
Torque-Summed  
Brushless DC Motors**

# Developmental EMA

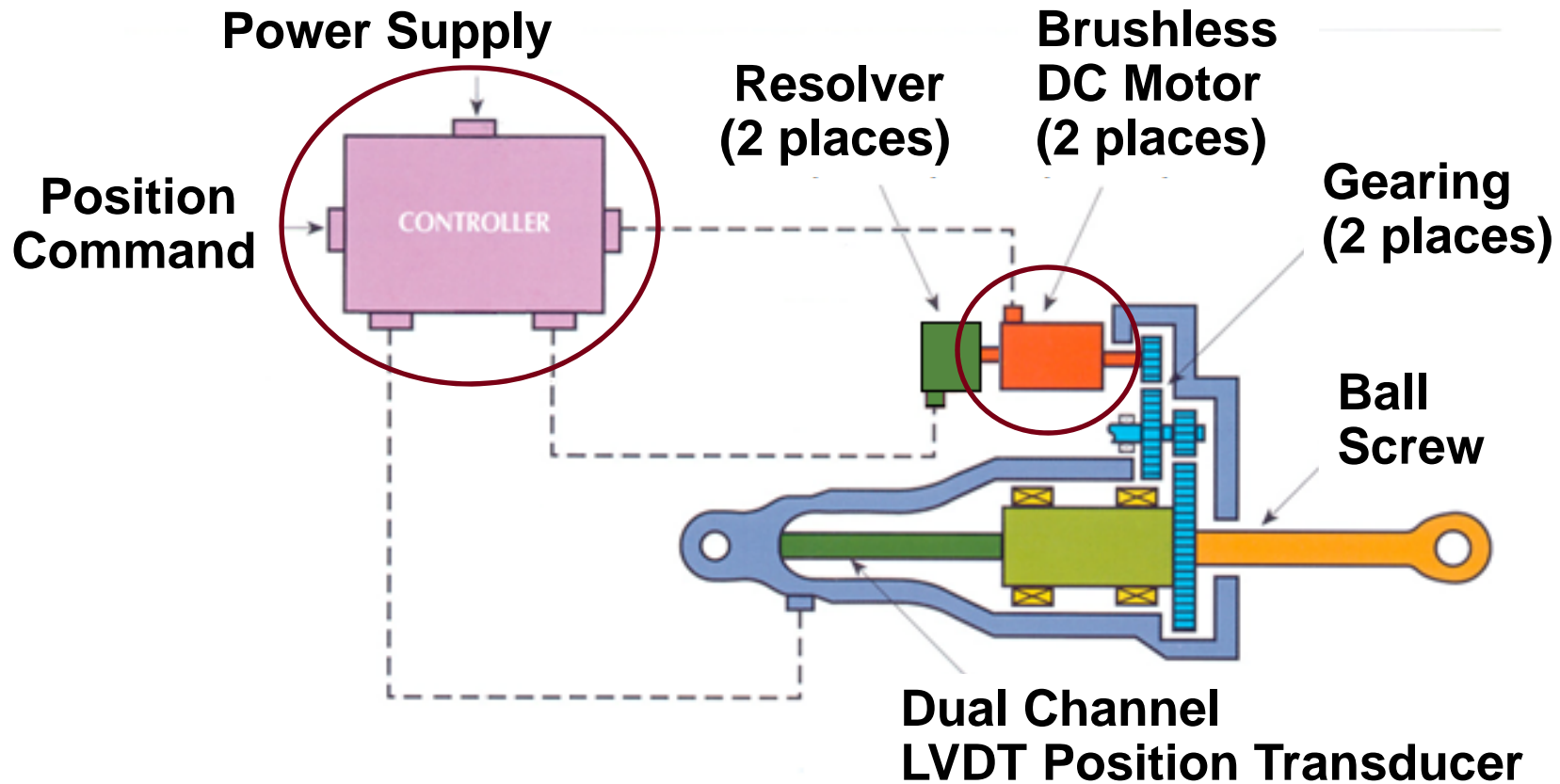

**Modern drive electronics and motor type enable regenerative braking function**

# Barriers to High Power ETVC

**Suitable electrical power source**

**Safety and affordability**

**Susceptibility to corona discharge**

**High voltage systems at high altitude**

**High reliability needed for human space flight**

**Availability of qualified high power electronics**

# Enabling Technologies

## Power Source

**High-Rate Lithium Ion (Li-Ion) Battery Chemistries**  
*Safe, high energy density*

## Power Electronics

**Insulated Gate Bipolar Transistors (IGBT)**  
*High reliability parts can be flight qualified*

## Control Electronics

**Field Programmable Gate Array (FPGA)**  
*Available radiation hardened parts*

# Establishing Technology Maturity

## **Human spaceflight qualified electronic parts**

**Examine availability of approved high voltage, high current power electronics from qualified manufacturers**

## **Corona discharge mitigation at high altitude**

**Acceptance of a 270 VDC bus requires corona mitigation and verification plan**

# Laboratory Testing

***Work presented here represents one phase in an ongoing development plan***

**Current phase:**

**High power electric TVC system based on two-channel electromechanical actuator**

**Next phase:**

**High power electric TVC system based on Multi-channel electro-hydrostatic actuator**

# Laboratory Setup

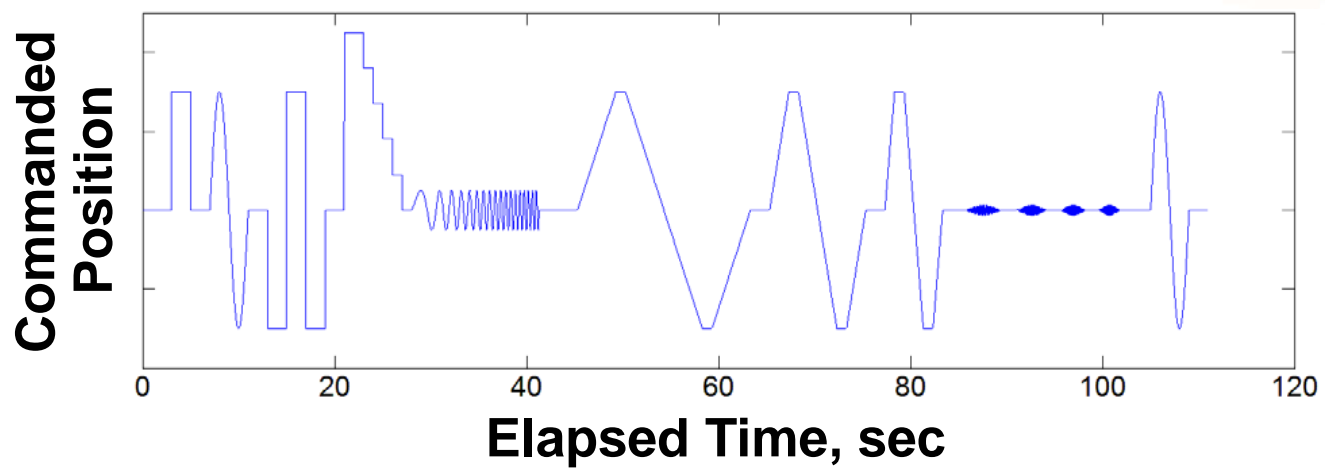
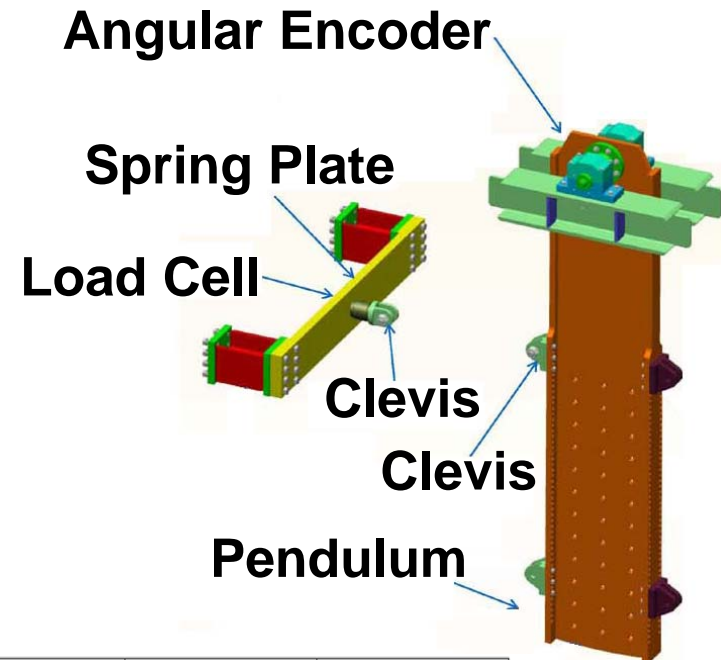

# Laboratory Setup

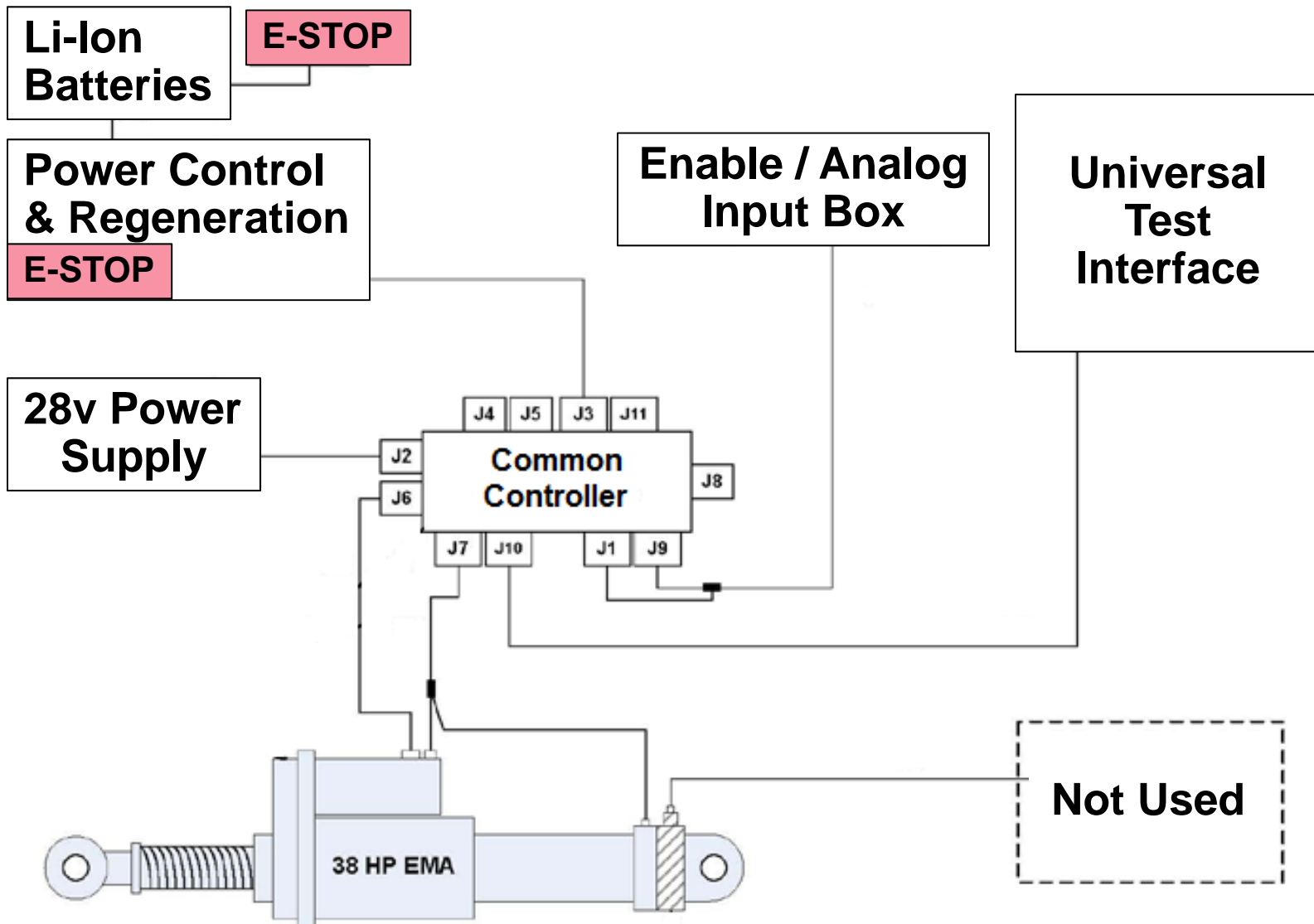



# Laboratory Setup

**Developmental Controller:  
Field Programmable Gate Array  
Insulated Gate Bipolar Transistors**

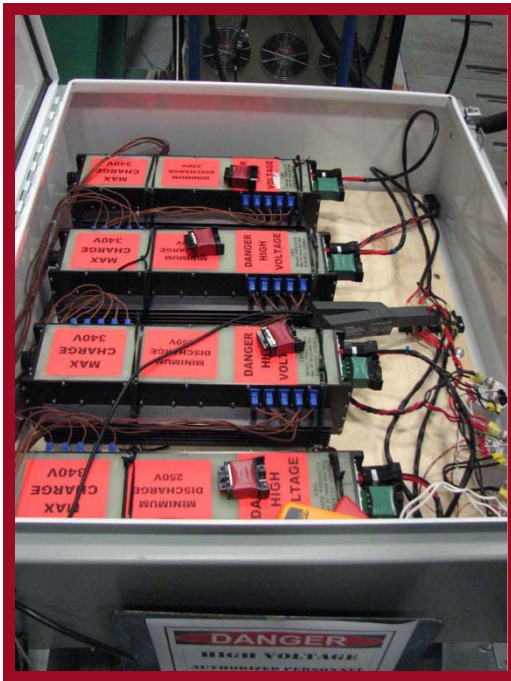

**Developmental Battery Module:  
Lithium Ion Chemistry  
Thermocouple Instrumented For Test**

# Test Objectives

1. **Functional integration of electric TVC components**
2. **Controller parameters tuned “in the field”**
3. **Peak power draw and voltage droop controlled to acceptable levels**
4. **Step and frequency response as expected for underpowered performance**
5. **Battery cell temperatures stay near ambient**
6. **Repeated operation on single battery charge**

# Test Results

## FREQUENCY RESPONSE: AMPLITUDE

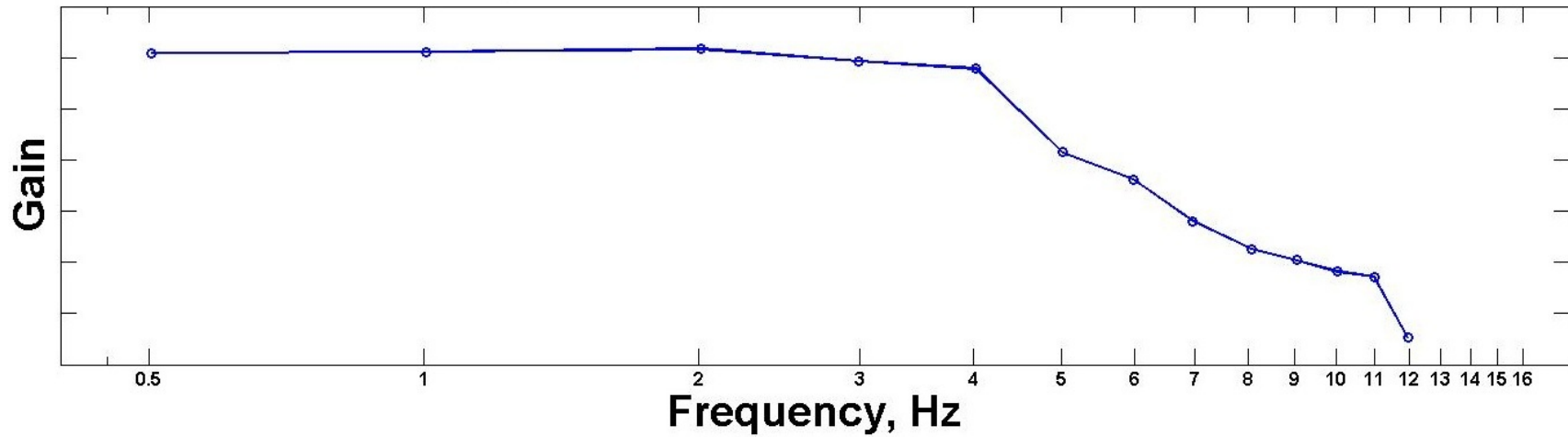

## FREQUENCY RESPONSE: PHASE

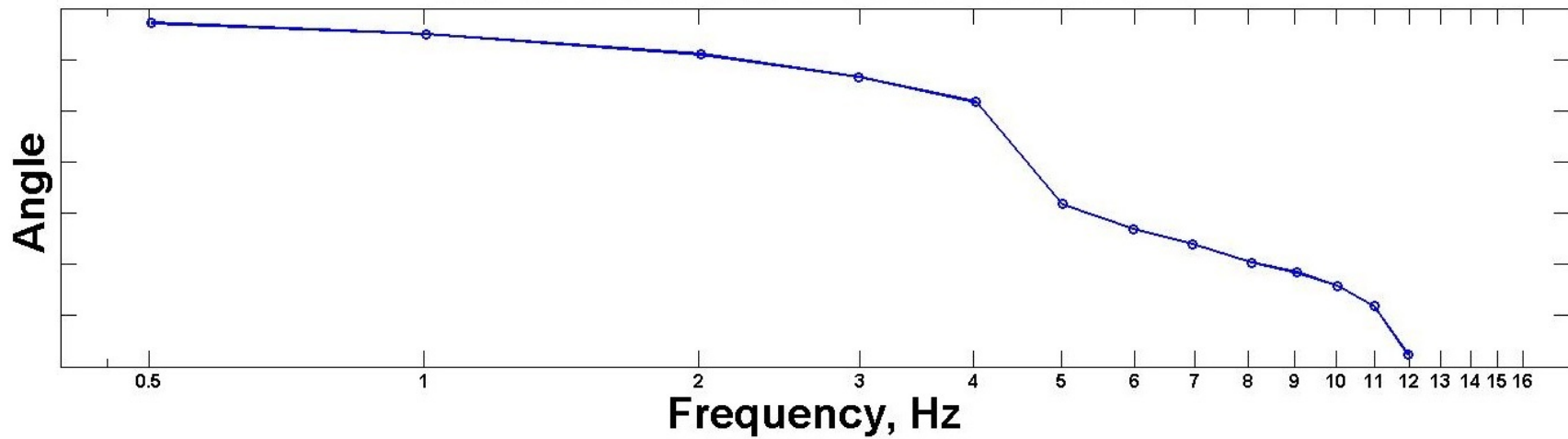

# Test Results

## STEP RESPONSE

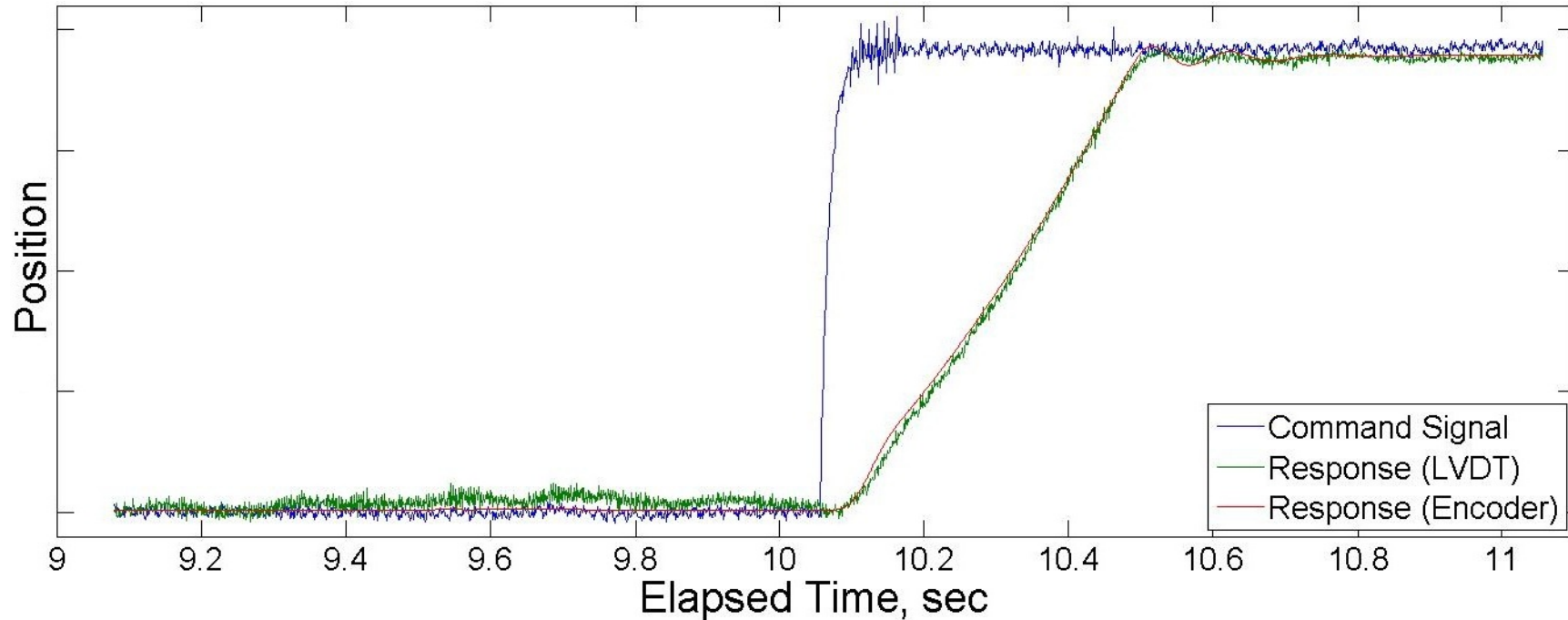

**Dynamic response agreed with expected performance for a controller optimized to under-powered conditions**

# Test Results

## BATTERY THERMAL LOG

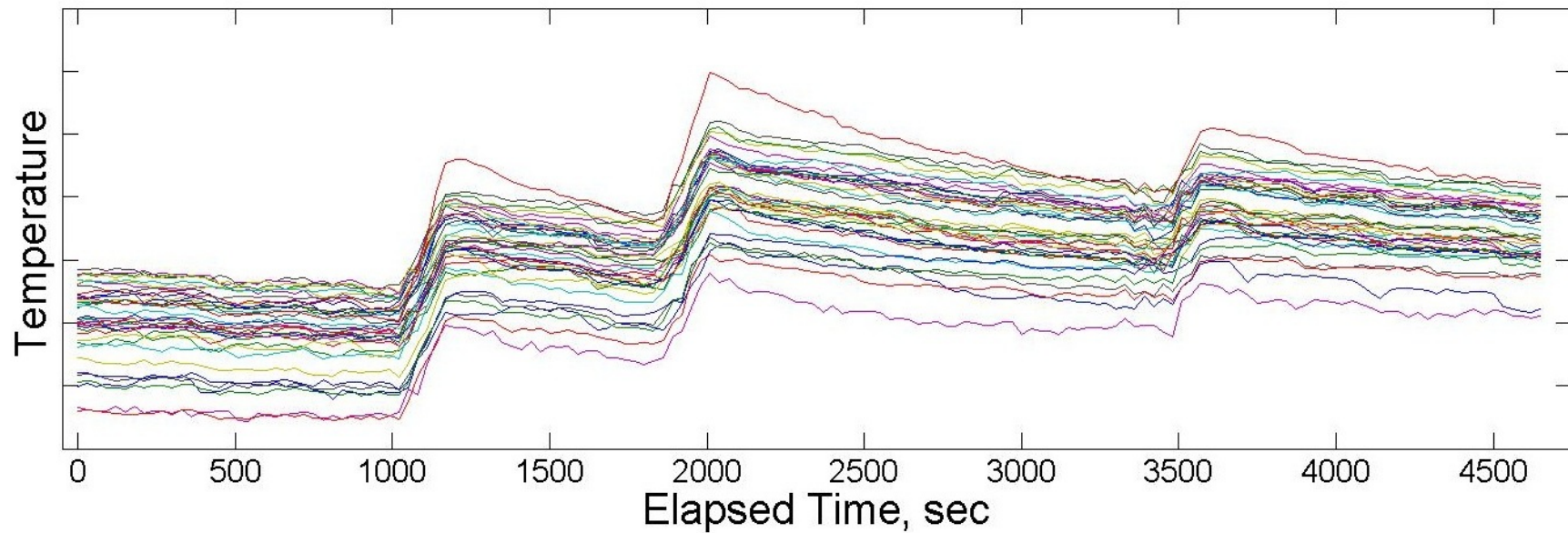

**Worst case recorded cell temperatures remained within a few degrees of ambient temperature**

# Electro-Hydrostatic Actuator

Electro-hydrostatic actuator to be used in the next phase of the development effort

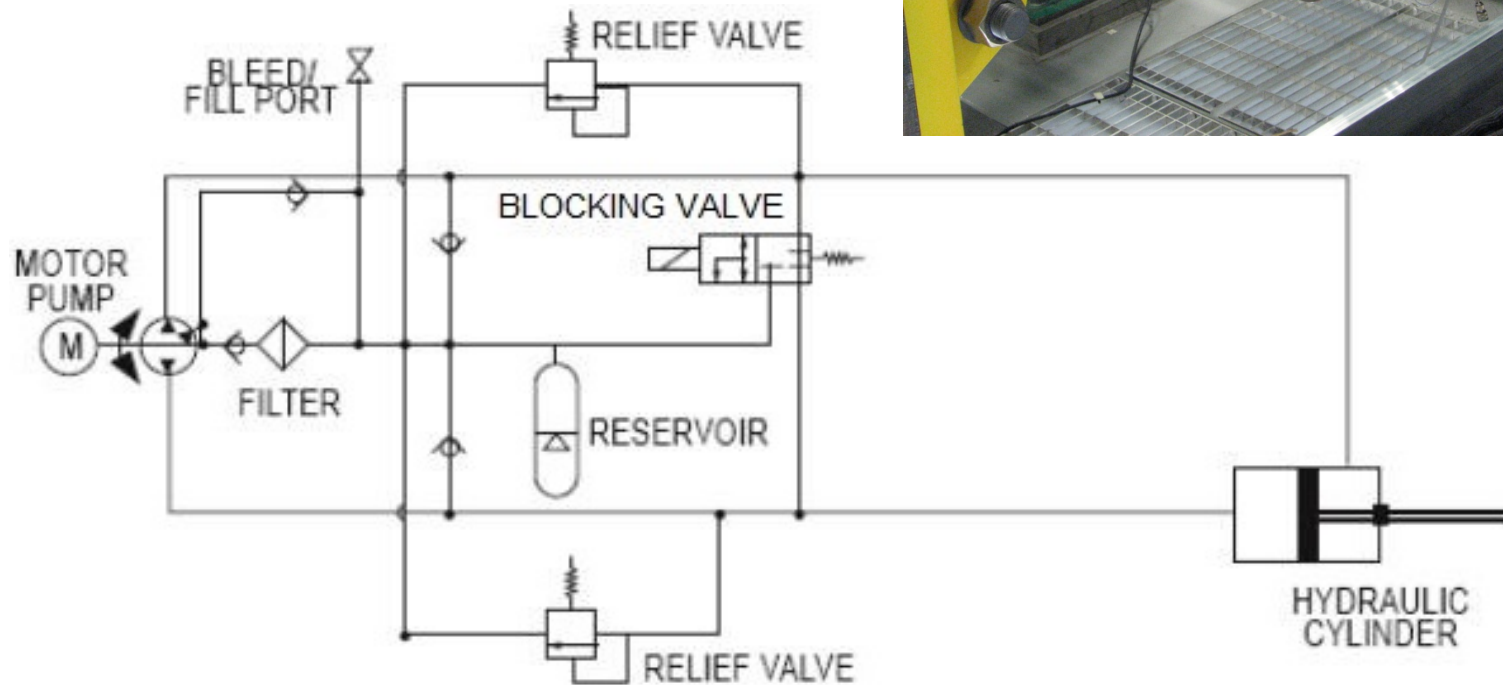
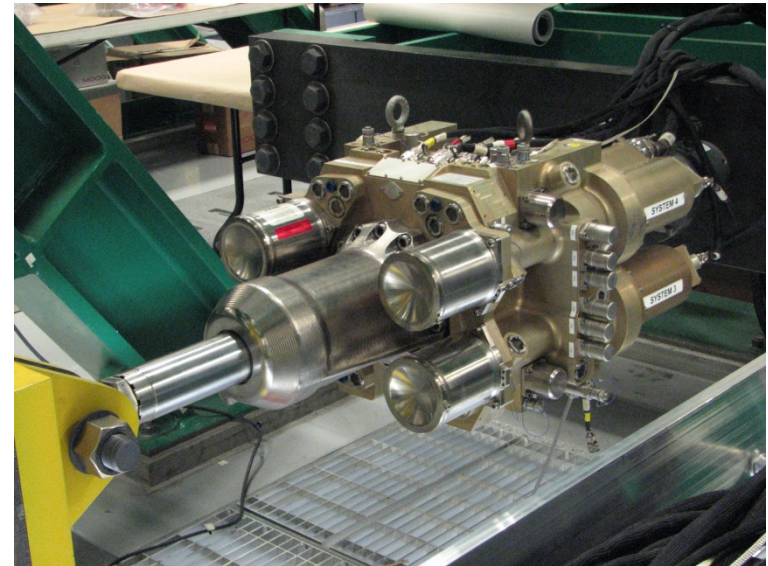

# **Developmental Testing of Electric Thrust Vector Control Systems for Manned Launch Vehicle Applications**

**41<sup>st</sup> Aerospace Mechanisms Symposium  
Pasadena, CA May 16-18, 2012**

**Lisa B. Bates**

**NASA George C. Marshall Space Flight Center**

**David T. Young, PhD**

**Raytheon / Jacobs ESTS Group, George C. Marshall Space Flight Center**