

2012 PWST Workshop Summary

NASA/JSC/George Studor

Location: La Jolla, CA

Sponsor: ISA Comm Division

Full Presentations(2012/2011) at:

**[http://www.isa.org/MSTemplate.cfm?Section=Papers_Presentations&Site=Computer_Tech__Division
&Template=/ContentManagement/MSContentDisplay.cfm&ContentID=89830](http://www.isa.org/MSTemplate.cfm?Section=Papers_Presentations&Site=Computer_Tech__Division&Template=/ContentManagement/MSContentDisplay.cfm&ContentID=89830)**

2012 PWST Workshop Agenda

June 6th AM

Session 1:

- 8:00am NASA/JSC/Structures SHM George Studor - "Passive Wireless Sensor Technology(PWST) 2012 Workshop Plan"
- 8:30am GE Global Research Daniel Sexton - "ISA107.4: Wireless sensor for turbine instrumentation working group"
- 9:00am United Tech Research Center Sanjay Bajekar - "Wireless for Aerospace Applications"
- 9:30am NAWCWD China Lake Rob Pritchard - "Naval Applications of PWST from the End-user's Perspective"
- 10:00am Break

Session 2:

- 10:30am BP/Chief Technology Office Dave Lafferty - "Passive Sensor Needs at BP"
- 11:00am Shell Ron Cramer - "Oil and Gas Integrity Monitoring"
- 11:30am DOT/FHWA Fred Faridazar - "Wireless Sensors for Structural Monitoring During Extreme Events"
- 12:00 - 1:00 Lunch

2012 PWST Workshop Agenda

June 6th PM

Session 3:

- | | | | |
|--------|---------------------------|-----------------|---|
| 1:00pm | Rockwell Automation | Cliff Whitehead | - "Machine-to-Machine Interfaces in Factory Automation" |
| 1:30pm | Arkansas Power & Electric | John Fraley | - "High Temperature Wireless Sensor Systems" |
| 2:00pm | Yokogawa | Penny Chen | - "PWST needs at Yokogawa" |
| 2:30pm | Break | | |

Session 4:

- | | | | |
|--------|--|------------------|---|
| 3:00pm | Savannah River Nuclear Solutions - Mike Mets | | - "PWST/RFID Technology for Material Control and Accountability at the Savannah River Site" |
| 3:30pm | On-Ramp Wireless | Jake Rasweiler | - "Ultra-Link High Capacity, Long Range Low Power Technology Applications" |
| 4:00pm | VTI Instruments | Chris Gibson | - "Integrating passive wireless sensors with existing data acquisition systems" |
| 4:30pm | AVSI Project AFE73 -WAIC | Radek Zakrzewski | - The Status of Wireless Avionics Intra-Aircraft Communications |

2012 PWST Workshop Agenda

June 7th AM

Session 5:

- | | | |
|--------------------|---------------------------|---|
| 8:00am Syntonics | Bruce Montgomery | - "Passive Wireless Sensing in a High-Multipath, High-Doppler Environment" |
| 8:30am Albido Corp | Fred Gnadinger | - "Wireless Passive Strain Sensors Based on Surface Acoustic Wave (SAW) Principles" |
| 9:00am Environetix | Mauricio Pereira da Cunha | - "Harsh Environment Wireless Sensor System for Monitoring Static & Rotating Components in Turbine Engines and Other Industrial Applications" |
| 9:30am nScript | Ken Church | - "Passive Direct-write Sensors" |
| 10:00am Break | | |

Session 6:

- | | | |
|------------------------------|---------------|---|
| 10:30am RF SAW | Paul Hartmann | - "Advances in SAW devices for Sensing and RFID Applications" |
| 11:00am ASRDC | Jackie Hines | - "PWST SAW - Sensor System" |
| 11:30am Univ of Cntl Florida | Don Malocha | - "SAW PWST: 915 Mhz Sensor System and Demonstrations" |
| 12:00 - 1:00pm Lunch | | |

2012 PWST Workshop Agenda

June 7th PM

Session 7:

- 1:00pm Carinthian Tech Research Heimo Mueller - "SAW Sensors: Explore New Measurement Horizons"
- 1:30pm Vectron Sabah Sabah - "Vectron Wireless Temperature Monitoring Solutions"
- 2:00pm MIT Auto-ID Lab Isaac Ehrenberg - "RFID Tag Antenna-Based Sensing"
- 2:30pm Break

Session 8:

- 3:00pm Tag Array Kourosh Pahlavan - "Passive UWB: long range, low cost and precise location"
- 3:30pm MaXentric Don Kimball - "60 GHz Comm, RFID moving to PWST"
- 4:00pm Wireless Sensor Technologies John Conkle - "Wireless Sensors for Gas Turbine Engines"
- 4:30 Aerojet Scott Hyde "A System Engineering Simulation Tool and Data Base Proposal for Optimizing the Application of Wireless Sensors"
- 5:00pm Workshop Closing George Studor - Discussion, Conclusions

Some History of Surface Acoustic Wave (SAW)

– courtesy Sabah Sabah, Vectron - Sengenuity

- 1880** Piezoelectricity, discovered by Jacques and Pierre Curie in quartz crystals`
- 1885** Lord Rayleigh characterizes Surface Acoustic Waves (earth quake)
- 1889** First interdigital electrode design, “Electric condenser” U.S. patent
Nikole Tesla
- 1965** First Interdigital Transducer (IDT’s) on a polished piezoelectric plate
(White / Voltmer)
- 1970** First applications: pulse expansion and compression in radar systems
- 1985** SAW filters replace LC filter in TVs and VCRs
- 1990** SAW filters allow for miniaturization of mobile phones
- 1990s** Passive Wireless SAW Sensors begin making their presence known.

Surface Acoustic Wave Technology Review

- Courtesy Sabah Sabah, Vectron-Sengenuity

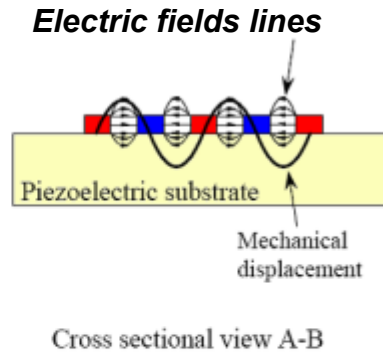
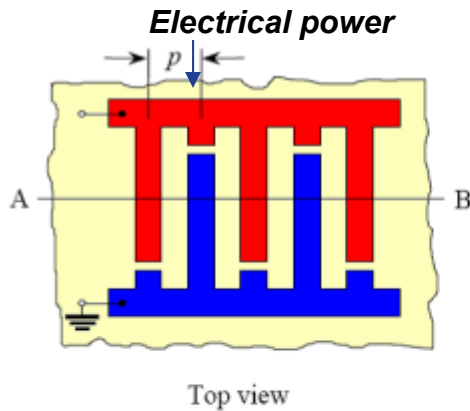

Wave propagation ≈ 3000 [m/s]

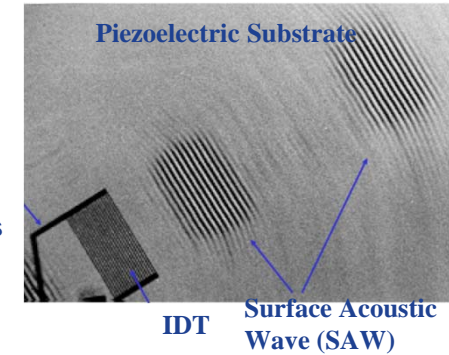
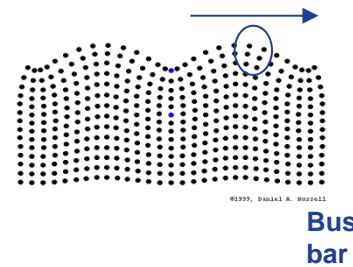

SAW - Rayleigh Wave propagation

Interdigital Transducer (IDT) as

- transmitter: converse piezoelectric effect \Rightarrow electric RF field generates SAW
 - receiver: piezoelectric effect \Rightarrow SAW generates electric RF field
- In both cases maximum coupling strength for $\lambda_{SAW} = v_{SAW} / f = 2 \cdot p$ ($\sim 1 \dots 10 \mu\text{m}$)

$$v_{SAW} = f_{SAW} \times \lambda \longrightarrow f_{SAW}(T, Cut, \dots)$$

SAW Resonator as Temperature Sensor

First Fact: Surface wave velocities are temperature dependent and are determined by the orientation and type of crystalline material used to fabricate the sensor.

Second Fact: Very low power is required to excite the acoustic wave – Energy Harvesting (EM-Wave)

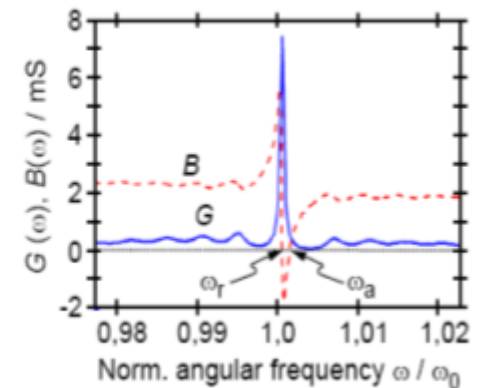
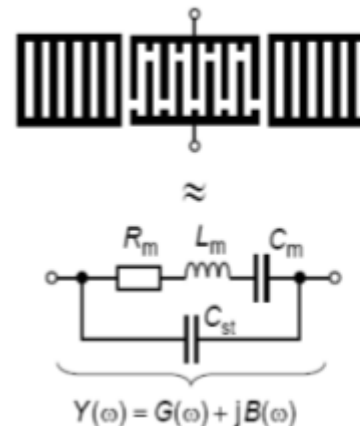

1.2 ISA107.4 Wireless Sensors for Turbine Instrumentation Working Group

Daniel Sexton - RF Instrumentation and Systems Laboratory
GE Global Research Niskayuna, NY - sextonda@ge.com

Scope: Wireless Instrumentation for Turbine Engine Test Cell :

Scalable architectures, system components, protocols, secure reliable wireless connectivity for test cell-based, multi-tier, active data transmission and passive wireless sensing, harsh environments

Basis for **future on-wing** engine health monitoring or control systems.

Purpose:

- Define Wireless interfaces, physical and RF environment
- Develop Multi-vendor interoperability support for various applications
- Develop co-existence support – possibly with other network standards

Future Activities:

- Technology Assessment and Gap Analysis
- Develop Needs Areas for Standards and Best Practices
- Users/Develop community develops Documents

Benefits of Creating a Standard:

1. System simplification
2. Compatibility between vendor equipment
3. Consistency in measurements
4. Reduced testing time and costs



Wires are a Common Problem

Level 0 - Engine (On/In-Engine – 1 ft)



Level 1 – Test Cell (Interrogators & Network – 50ft)

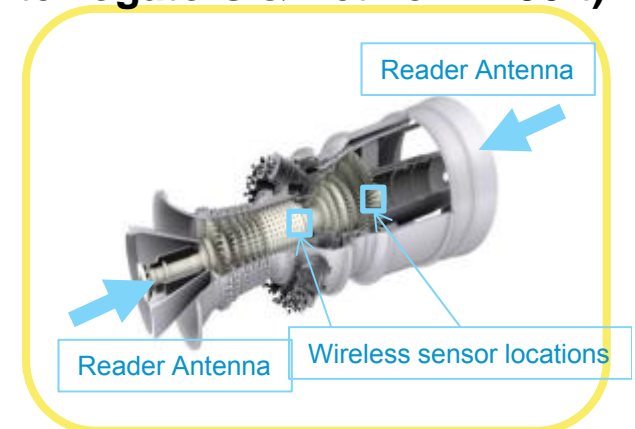

1.3 Wireless Technology for Aerospace Applications

Sanjay Bejkal – UTRC East Hartford, Conn. - BajekaS@utrc.utc.com

Wireless Needs:

- Long term health monitoring of the airframe and structures
- Short term health monitoring of targeted/specific issues using peel & stick sensors
- Security – resistance to intentional RF interference & protection from eavesdropping

Countermeasures:

- Frequency Hopping systems over large frequency bands (>500 MHz)
- Antenna Gain pattern (fixed and adaptive phased arrays)
- Adaptive Tx power control (burn through)
- Coding
- Novel Technologies (Magnetic comm, Free space optics, Higher freq > 40 GHz)
 - Mag comm can have 3 orders of magnitude less susceptibility to eavesdropping vs RF

Energy Harvesting:

- Combine sources – PV, Mechanical, Remote RF
- Power Storage – Ultra Capacitors or thin film rechargeable – Printed Zinc batteries

System Integration:

- Communication Range
- Protocols: Physical and Software Stacks

Passive Wireless Potential: Low Cost - Short & Long Term Health Monitoring, Security

1.4 Naval Applications of PWST from the End-user's Perspective

Robert Pritchard – Navair, NAWCWD China Lake robert.w.pritchard@navy.mil

Potential Uses of PWST:

- **Condition-based Maintenance**
 - Energy Autonomy – e.g. thermal scavenging for external skin sensors
 - Event Monitoring – e.g. munitions comm link integrity –voltage drop at umbilical
 - Energy Harvesting – e.g. helicopter blade damage, pitch link dynamic loads
- **Health Management/Monitoring and Inventory Management**
 - Ext Environment where munitions have been -Temp, Humidity, Vib, Shock, Chem, etc
 - Internal Conditions – Temp, Press, Humid, Stress/Strain, Chem, Corrosion, Leak, etc.
 - Detection, Identification, Location, Remote Sensing(Encryption for Security)
- **Anti-Tampering(DOD and DHS)**
 - disable LIVE/DUD munitions – remotely commanded or self-destruct
 - sense tampering
- **Power Systems:** Improve Isp, Mass Fraction, Cost, Uncertainty, Reliability
 - Novel Ocean(Thermal) Powered Underwater Vehicle – NASA/JPL
 - Energy Mgmt/System Control: Press, Temp, Power, RPM, Fuel Flow, Vol, Haz Gas
- **JANNAF sponsored Space and Military Wireless Sensor Systems Workshops**
 - Co-chairs: Pritchard and Dr. Tim Miller/AFRL - EAFB
- **OPNAV Ordnance RFID Implementation Policy(Aug 2008)**
- **List of Challenges, Approaches, Critical Measurements, “Low Hanging Fruit”**
- **Desirable Wireless Sensor Features and Approaches**

2.1 Passive Sensor Needs at BP

Dave Lafferty – Chief Technology Office - david.lafferty@bp.com

BP: Worldwide – Down-hole, Transport, Refine, Market – 80,000 employees

Fundamentals of Sensing: Deploy > Measure > Communicate > Take Action

PWST Applications that work/should work:

- Rotational Equip/ Shafts, Flames, Cement, Turbine Tips, Gas Detection,

Specific PWST Use Cases needing solutions:

- Corrosion Under Insulation (Indicators – Moisture, Humidity, Ph)
- Down-hole Cement between casing and rock(level, temp, strain)

Potential PWST Use Cases:

- Difficult to inspect locations
- Operating in hostile environments
- Extend the service life of assets beyond their designed life
- Reducing and managing risk via measuring the environment

2.2 Oil and Gas Asset Integrity Monitoring: the Needs and Challenges

Ron Cramer - Shell International E&P Inc. - Ronald.Cramer@shell.com

- Safety, Sustainability, Security, Ubiquitous Sensors
- Remote Sensing
- Health Care
- MEMS: versatile, powerful, reliable, cheap
- Measure any variable under multiple conditions
- Bring Cost Down, Performance Up
- Sub-Sea Integrity and Leak Detection

Approach

- Prior applications in other industries
- Conversion to O&G – Algorithms to convert signal to info
- Integration into a functional system
- Partnership with technology suppliers: industry & academia
- Quick route to failure – Game-changer

Sensor Elements

- MEMS for Vibration, acoustic detection, temperature
- SONAR, RADAR
- Magnetic detectors
- Ultrasonic

Common Systems

- Existing and emerging sensors
- Power generation and storage
- Signal conditioning and transmission
- Networking
- System architecture
- Data analysis

Systems

- Autonomous underwater vehicle
- Fixed subsea sensor networks
- Fixed acoustic/temperature/chemical/US sensors network onshore
- Versatile and expandable framework

2.3 Wireless Sensor Monitoring of Structures During Extreme Events

Fred Faridazar - Turner-Fairbank Highway Research Center (TFHRC) McLean, VA fred.faridazar@dot.gov
<http://www.fhwa.dot.gov/advancedresearch/index.cfm>

Exploratory Advanced Research Programs

David.Kuehn@dot.gov; terry.halkyard@dot.gov

Integrated Highway System Concepts

- International approaches: vehicle automation

Nano-scale Research

- Measurement of dispersion

Human Behavior and Travel Choices

- Dynamic ridesharing
- Vision assisted technologies

Energy and Resource Conservation

- Sustainable underground structures
- Electric vehicle commercialization

Information Sciences

- Video decoding, feature extraction
- Probabilistic record linkage (data mining)

Breakthroughs in Materials Science

- “Self-healing” materials
- Cement hydration kinetics

Technology for Assessing Performance

- “Smart balls” for autonomous culvert inspection
- Pressure sensitive paints for aerodynamic testing;
- Remote sensing for environmental processes

Infrastructure

- Pavement Materials
- Pavement Design and Construction
- Long Term Pavement Performance
- Bridge and Foundation Engineering
- Hazard Mitigation
 - Flood, Seismic, etc.
- Infrastructure Management

Operations and Safety - david.yang@dot.gov

www.fhwa.dot.gov/research/tfhrc/programs/safety

- Human Factors
- Intersections
- Pedestrian & Bicycles
- Roadway Departure
- Speed Management
- Comprehensive Safety – Predicting Societal and
 - Complex Natural Systems



3.1 Machine-to-Machine Interfaces in Factory Automation

Cliff Whitehead – Rockwell Automation - cjwhiteheadjr@ra.rockwell.com

What if machines could report: their “health”?

- vibration of rotating equipment
- motor winding temperature
- oil or lubricant temperature or quality



their production?

- good parts or batches
- substandard parts or batches
- scrap or waste
- consumable materials used
- energy or utilities consumed



their “inventory”?

mechanical components
electrical components – including those
inside control cabinets
changeover parts
spare part requirements



their “location”?

work cell name
work cell unique identity
physical location inside the plant
operational status
safety status
upstream and downstream interfaces



Wireless in Automation Today:

Most prevalent in higher latency, non-deterministic monitoring applications

- Temperature, Flow, Vibration

Attractiveness stems from:

- Standard interfaces to well-established industrial network protocols (e.g., EtherNet/IP)
- Field-based devices for wireless interrogation and data translation

Challenges arise when speed is important

Summary:

Passive wireless sensing has promise for Factory Automation applications

The challenge is competing for mindshare with other wired and wireless technologies, and “the way it’s always been done”

Standards play a role by exposing user and technical requirements that can challenge our industry to advance our efforts to meet those requirements that are currently unmet is important

3.2 High Temperature Wireless Systems

John R. Fraley/Byron Western – Arkansas Power Electronics - jfraley@APEI.net

Why High Temperature Wireless?

- Data Collection from Rotating Components
- Increased SNR from Sensors
- Reduced Weight from Cabling
- Distributed Systems
- Improved Process Controls

Overview:

Motivation

Applications:

Aerospace: HM for Bearings & Gearbox
Distributed Engine Controls

Geological Exploration: Temp, Press, Flow
Wireless Drill Head Control

Power Generation: Turbine Blades, Condition-based maintenance, Smart Turbine Control

Industrial Processes: Manufacturing and
Chemical Process Monitoring

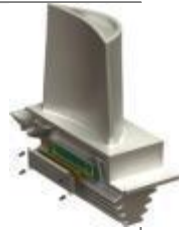

Technical:

Enabling Technologies:

HTSOI: rated 225 °C and operable to 300 °C.

Wide Band Gap semiconductors up to 600 °C

Low Temp Co-fired Ceramic – multi-layer circuit

Energy harvesting Vibr, RF, TEG

Bearing Sensor Design

Blade Sensor Design

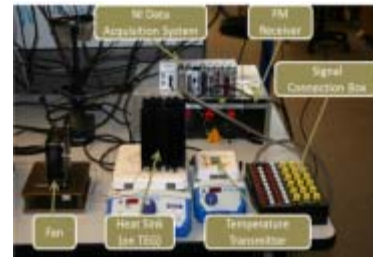

Testing Facilities:

Bearing Tests-AFRL



Spin Tests-Aerodyne

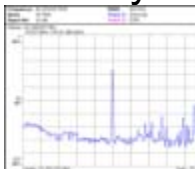

What's Next?

- Energy Harvester & Transmitter in Single Package
- HTSOI and SiC ASICs
- Integrated Sensors
- Improved Power Conditioning



3.3 PWST Needs At Yokagawa

Penny Chen – Yokagawa Corporation of America -
penny.chen@us.yokogawa.com

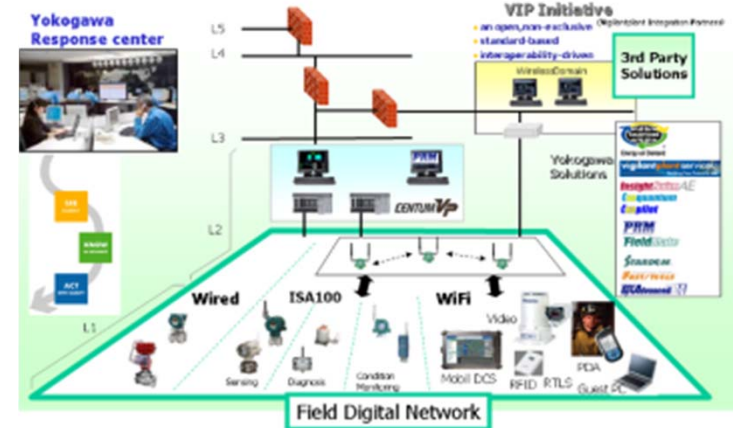

Future PWST Measurement Needs:

- Corrosion
- Humidity
- Optical, Infrared
- Pressure, Tension
- Gas, CO2, Smell
- Vibration
- Acoustic Emission
- Temperature
- PH, Liquid Level, Flow
- Location, Proximity
- Valve position

PWST Challenges:

- Industrial environment :
- Life reliability & stability
- System scalability
- Robust, secure wireless
- Large Data Volume
- Low initial entry cost
- Variety of sensor types
- Coexistence w/wireless
- Open standards

Vigilantplant:

See Clearly
 Know in Advance,
 Act with Agility

	Requirements	Key technologies	Our Solutions
4:Application	<ul style="list-style-type: none"> -Full Automation -Full Navigation -Opt. Performance 	<ul style="list-style-type: none"> -Simulation -Advanced HMI (3D, MM, VR) -Production Traceability 	<ul style="list-style-type: none"> - Scenario-based Operation - Augmented Reality - Predictive Navigation - Advanced Optimization
3:Control	<ul style="list-style-type: none"> - Robustness - Integrity - Flexibility 	<ul style="list-style-type: none"> - Asynchronous Control Algorithm - Predictive control 	<ul style="list-style-type: none"> -plac-PID for continues control block -Shadow function block -APC, Opt. controller
2:Connection	<ul style="list-style-type: none"> - Reliability, Robust - Deterministic - Min. Latency, Jitter - Scalability - Interoperability 	<ul style="list-style-type: none"> -Full Redundancy (Duo cast, Gateway) - TDMA scheduling - FB communication 	<ul style="list-style-type: none"> - Redundant Gateway - Star topology by Duo cast / dual BBR -MM comm. On BBR - Reliable/long range Radio Comm.
1:Device	<ul style="list-style-type: none"> - Long Battery life - Growing Intelligent - Function block 	<ul style="list-style-type: none"> - Higher battery Capacity - Low power consumption -Energy Harvesting -Diagnostics -Intelligent Application 	<ul style="list-style-type: none"> -Standard battery case/pack with long life -Zone1 replaceable battery -Extending antenna cable -High gain antenna

4.1 Passive Wireless Sensor Technology for SRS Material Storage

Michael Mets - Process Controls and Automation Technology,
Savannah River Nuclear Solutions, LLC - michael.mets@srs.gov

SRNS: M&O Contractor, DOE Savannah River Site, Aiken SC
Nuclear Materials Storage Mission:
- Handling, Storage & Surveillance of Plutonium and other NM

Challenges for RF Systems:	
Physical Environment	Reflective & Attenuating Surfaces
Regulatory Environment	Various Sources of EMI
Spectrum Supportability Auth.	Coexistence with Legacy Equip.
Procurement Authorization	Harsh Environmental Conditions
Risk Assessment	Significant Radiation Levels
Security and Test Plans	

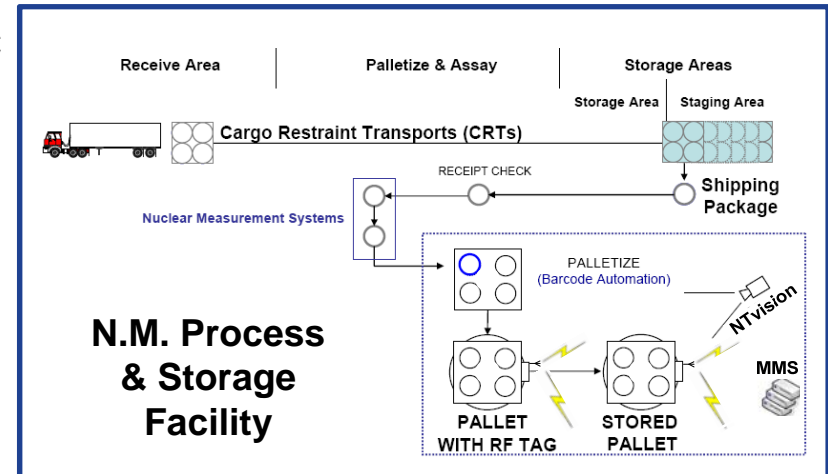

Passive Wireless Sensor Wish List

- **Low cost <\$500**
- **-40° to +85° C ambient ops**
- **RF low power**
- **Security (AES 128-bit encryption) - NIST**
- **Authentication (AES 128-bit CMAC) - NIST**
- **Store messages locally**
- **Fiber optic loop (up to 50m)**
- **Remote data collection**
- **Real time clock**
- **Tamper detection**
- **Radiation Monitoring and Reporting**
- **Temperature & Humidity Monitoring**

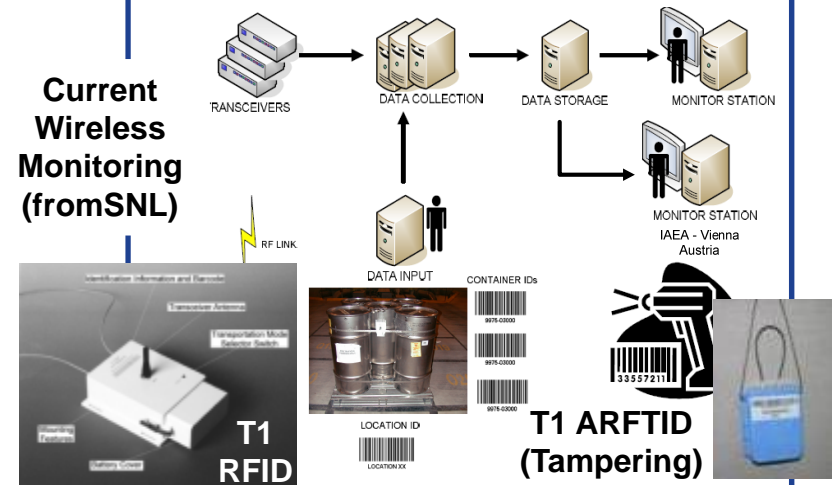

NEW: Remotely Monitored Seal Array (RMSA)
- 902MHz - Sandia N. Lab



ARG-US RFID
- Argonne N Lab



4.2 Introduction to On-Ramp Wireless

Jake Rasweiler – On-Ramp Wireless - jake.rasweiler@onrampwireless.com

“Ultra-Link” Technology

Applications:

- Utilities, Smart Grid
- Process Industries
- Personnel and Asset Tracking
- Critical Infrastructure

System Goals:

- Lowest Total Cost of Ownership
- Best Coverage in Industry
- Connectivity in Hardest to Reach Areas
- Immense Capacity
- Seamless Support for Battery Devices
- Robust Operation in Noisy ISM Band

Performance Metrics:

- Coverage
- Capacity
- Coexistence
- Power
- Security
- Cost
- Deploy Schedule?

Application Type	Data/Day	#Nodes per AP*
Electric AMI Meter	2.4 KB	20,000+
Hazardous Alarms	100 bytes	100,000+
Pressure Sensor	100 bytes	100,000+
Cathodic Protection	100 bytes	100,000+

Installations: stationary during RF Ops, underground, in containers or Indoors, wide area coverage

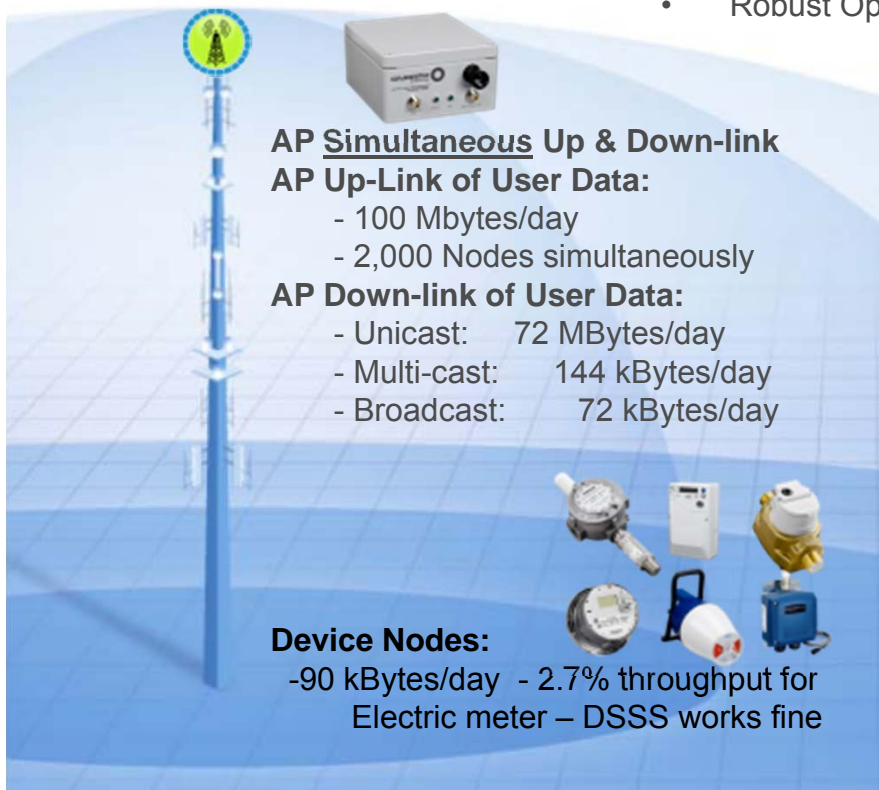

AP Simultaneous Up & Down-link
AP Up-link of User Data:
 - 100 Mbytes/day
 - 2,000 Nodes simultaneously

AP Down-link of User Data:
 - Unicast: 72 MBytes/day
 - Multi-cast: 144 kBytes/day
 - Broadcast: 72 kBytes/day

Device Nodes:
 -90 kBytes/day - 2.7% throughput for Electric meter – DSSS works fine



San Diego Area:
 35 Access Points
 4,000 miles
 200,000 device-nodes

Also: Niger Delta Oil/Gas Pilot Deployment
 10,000 km2 area Avoid theft/leaks
 challenging terrain Battery operated

DSSS: Spreading factors up to 8192 chips/symbol gets up to **39 dB of processing gain**
 Receiver sensitivity is -133 dBm on downlink
 -142 dBm on uplink

4.3 Integrating Wireless Sensors with Existing Data Acquisition Systems

Chris Gibson –VTI Instruments, Irvine CA - cgibson@vtiinstruments.com

What is important to End Users?

(Wireless Opportunities in Red - Bold)

Gen Purpose/High Speed Data Acquisition

- Cost/channel
- Accuracy
- **Ease of Use**
- **Quick test setup and teardown**
- Ability to distribute across large area
- Turnkey software, or min development effort
- Software tools to roll their own application
- Data processing done post test
- Continuous sampling important (no gaps)

Modal Ground Vibration Testing

- Distribute the measurements close to the structure
- **Cables add mass and damping, I need to manage this**
- Simultaneous sampling -eliminate channel/channel phase skew
- The ability to move lots of data is very important
- Turnkey software is historically required
- Data is analyzed in the frequency domain
- Move raw data and have the PC do the analysis/processing

Rotational Machinery and Order Analysis

(Turbine Generators, Drive Train, Transmissions, Windmills)

- Repeatability of measurements is a must
- High performance Tachometer inputs simply setup
- **I need to measure rotating mass**
- Data will be re-sampled for order domain analysis
- Phase angle/sampling , Tach accuracy important for balance ops
- Turn key software solutions are desired
- Distributed Sensing
- Software tools that they can use to roll their own application

Typical VTI Test Sites

- Jet engine Test Cells
- Rocket engine Test Cells
- White Good Manufacturers
- General Automotive Testing
- Battery/Solar Cell Testing

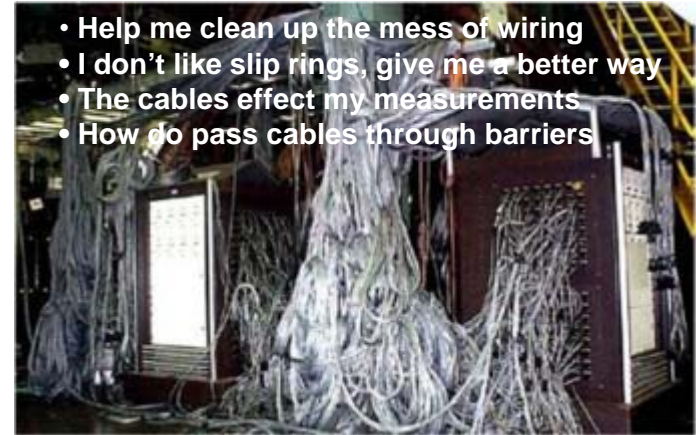

- Help me clean up the mess of wiring
- I don't like slip rings, give me a better way
- The cables effect my measurements
- How do pass cables through barriers

Static Structural and Fatigue:

- **The ability to place the instruments close to the structure to minimize cable lengths**
- Synchronization for improved data understanding in the event of a failure
- Front end configuration flexibility, support multiple transducer types (load, strain, pressure, displacement)
- **Scalability is critical - these can become very large tests**
- Turnkey software is preferred, ease of use
- **Help me manage channels for large test configurations**

Temperature Testing/Test Cells

- Repeatability of measurements is a premium
- Temperature accuracy
- **Easy connectivity, mini-TC simplifies setup**
- OTD shows failed channels before critical testing
- Measurement stability, some tests last for a long time
- Distributed measurements ease setup and reduce noise
- Real time limit checking with alarm or shutdown capability
- Software tools that they can use to roll their own application

4.4 Protected Spectrum for Wireless Avionics Intra-Communications

Radek Zakrzewski – AVSI Project AFE73 Chair - radek.zakrzewski@goodrich.com

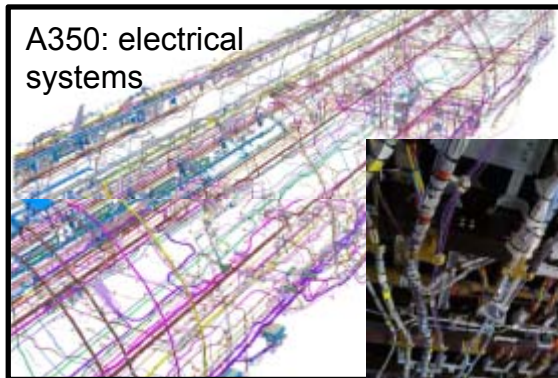

A350: electrical systems

Typical wiring installation in A380 crown area (above ceiling panels)

About 30% of wiring can be potentially substituted by wireless

A380-800 wiring:

- Total wire count: ~100 000
- Total wire length: 470 km
- Total weight of wires: 5 700 kg
- Add 30% more for **wire mounting**

Motivation:

Reconfigurability: Efficient cabin or other changes/upgrades(e.g. Wireless – relocatable-Oxygen Supply Unit)

Safety: Dissimilar or Added redundancy, Fewer mechanical failures

Efficiency/Environmental: Less fuel burned due to reduced weight

Reliability: reduce aging wiring, data for aging aircraft

Challenge: Obtain Protected RF Spectrum World-wide needed for aircraft OEMs to install RF systems

(License-free – ISM – bands not suitable for safety-critical uses)

Aerospace Vehicle System Institute(AVSI) Consortium – www.avsi.aero – David Redman

WAIC – Wireless Avionics Intra-Communications – On-board, not air-to-ground, air-to-air, air-to-space

Project AFE73 – began in 2008 – **Members:** Airbus, BAE Systems, Boeing, Bombardier, Embraer, Goodrich, **Goals:**

Gulfstream, GE Aviation, Honeywell, NASA, Sikorsky

- Develop Technical justification and broad support for Protected Spectrum request - ITU-R
- Receive Protected Frequency for WAIC systems world-wide at World Radiocommunications Conference

Progress: **WRC-12 (Feb 2012) adopted and Agenda Item for WAIC, WRC-15 will vote on proposal in 2015**

ITU-R M.2197 Report: http://www.itu.int/dms_pub/itu-r/opb/rep/R-REP-M.2197-2010-PDF-E.pdf

WRC15 Agenda Item: <http://legacy.icao.int/anb/panels/acp/wg/f/wgf26/ACP-WGF26->

[WP13 WAIC%20AI%201.17%20draft.doc](#)

Next: Detailed Sharing Studies must be accomplished in preparation for 2015.

5.1 “Passive Wireless Sensing in a High-Multipath, High-Doppler Environment”

Bruce Montgomery – Pres. Syntonics Corp - Bruce.Montgomery@syntonicscorp.com

RF Propagation in Jet Engines:



RF Transmission Testing:

- GE CF6-50 at WPAFB
- Small: GD F-16 engine, Large Boeing 747 engine
- Circular Polarization and Radial Polarization
- Signal loss can be less than in free space's $1 \div R^2$
- Signal Energy is spread out in time: initial and reflections
- Investigated EM “Windows”
- Multiple reflection time corresponds to 3x compressor size
- Time domain: Discerned Individual stages, not blades
- Internal compressor propagation is axial, not circumferential or spiral
- “Cutoff” frequency – for F16, 30db losses below 5.2 GHz

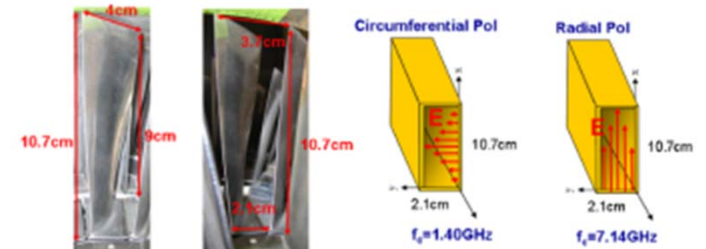

RF Modeling:

- Inserted “scatterers” at several points between transmitter-receiver
- Added waveguides to Model

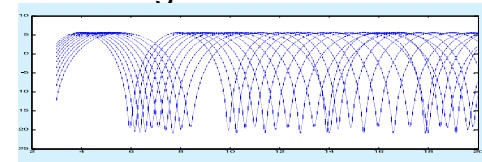

RF Passive Sensor Testing:

SAW device and resistive strain gauge Measurements the same

- Cantilever Strain Measurements

- Harmonically Driven

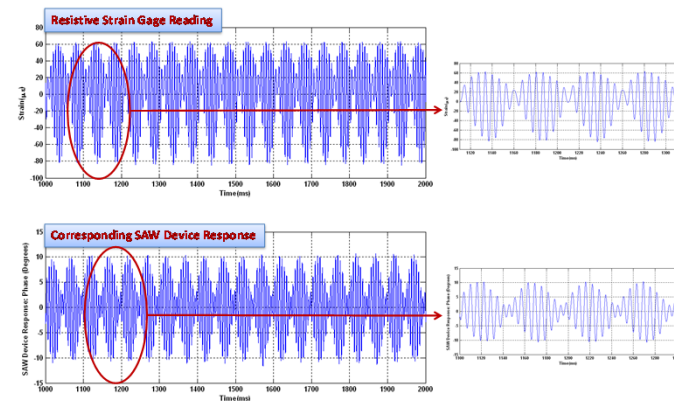
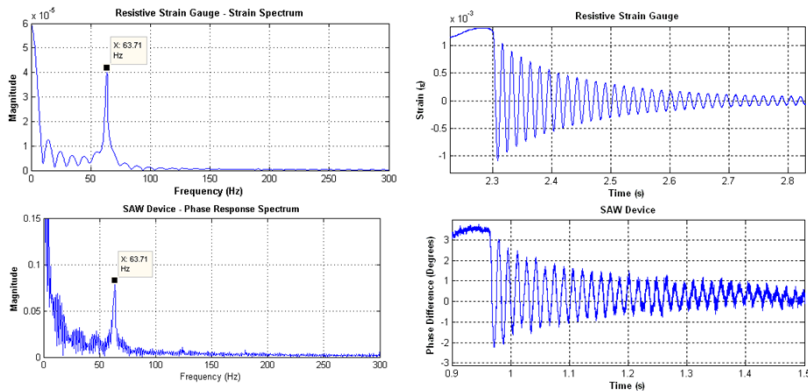

5.2 “Wireless Passive Strain Sensors Based on Surface Acoustic Wave (SAW) Principles”

Fred Gnadinger – Pres&CEO Albido Corp - fred@gnadinger.com; www.albido.com

Navy STTR Program
ONR COTR – Scott Coombes

Albido Passive Wireless SAW Sensors Coded

- Large bandwidth, high speed
- Large read range
- Small, rugged, cheap
- Noise tolerant, no cross sensitivity
- Low loss and variable frequency
- Radiation hard for space applications
- Physical, chemical and biological parameters
- Wide temperature range and harsh environment
- new temp compensation method

Cantilever Strain Test:

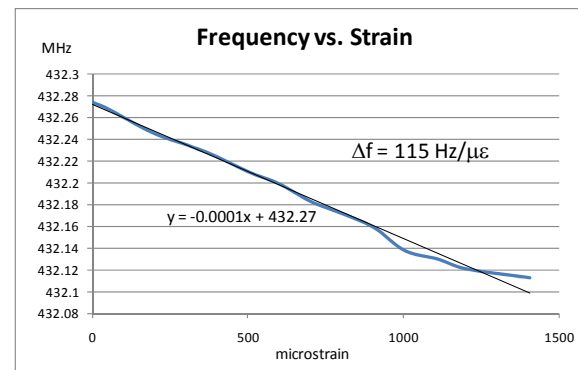
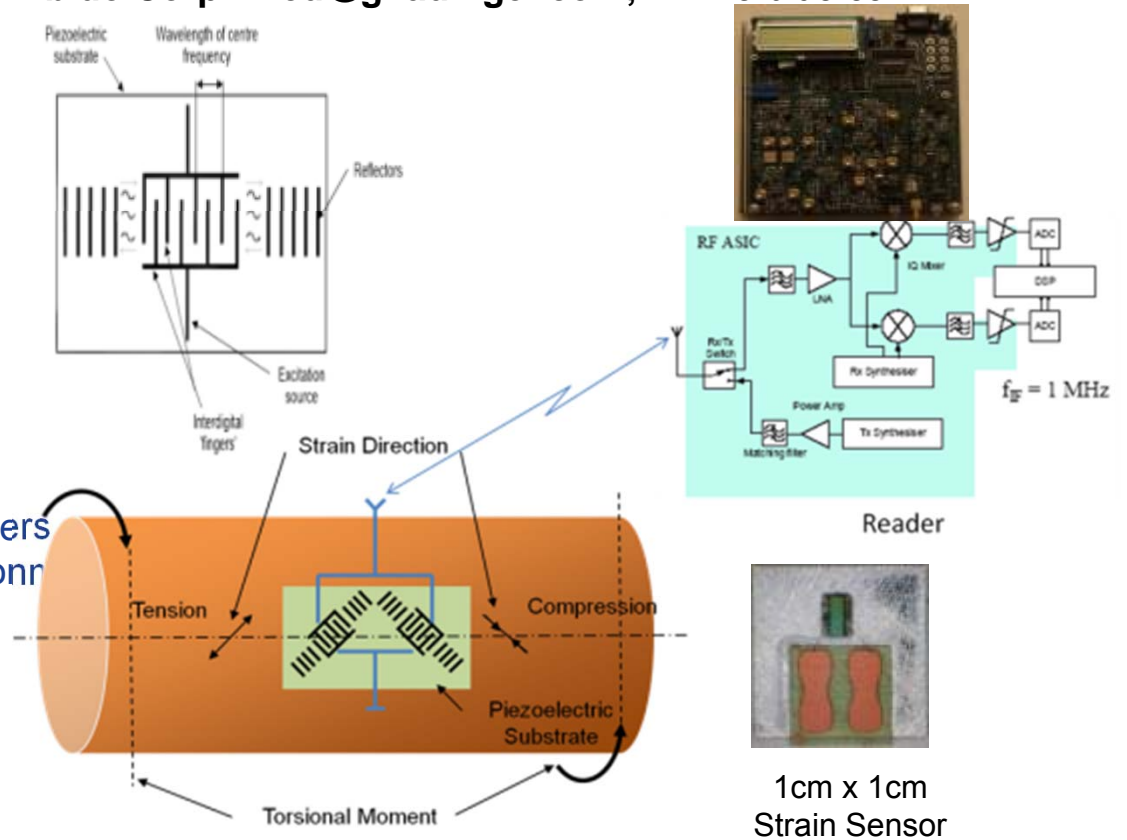
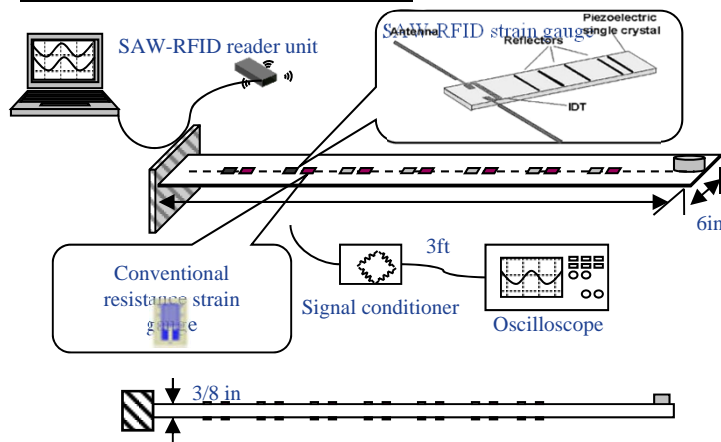

5.3 “Wireless Microwave Acoustic Sensor Systems for Harsh Environments”

Mauricio Pierera da Cunha –Environetix- mdacunha@environetix.com www.environetix.com

Environetix Passive Wireless SAW Sensors

- Stable and reliable operation up to 900oC (1650oF)
- Wireless RF interrogator electronics
- Custom installation on rotating or static parts
- User-friendly data output on laptop PC
- Proprietary sensor packaging and attachment
- Multiple strain and temp sensors - integrated RF antennas
- Dyn Strain, pressure, corrosion , pressure sensors in work
- RF Frequency: 100MHz to 1GHz depending on need
- LANGASITE LA3GA5SIO14 Piezoelectric crystal
 - Stable up to 1400oC - Thermal shock resistant



90,000rpm
53,000 G

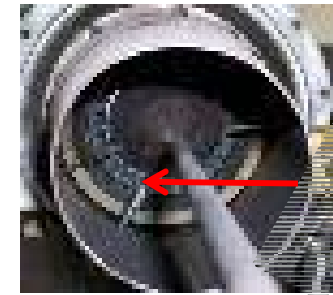

ARMFIELD CM-4



GE CT7 / T700

Demo s at Power Plants, Furnaces, Engine Exhausts
- up to 1200oC (2200oF)

EVHT-100 for multiple Temperature Sensors



TMC85-1

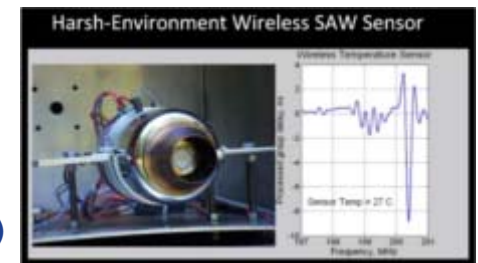

JETCAT P-70 & P-80

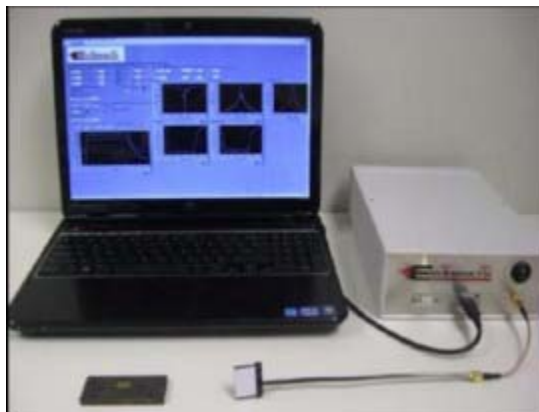

- temperature range: 150oC (300oF) to 900oC (1650oF)
- accuracy: ±10oC over full range
- resolution: within ± 5oC
- long term drift: < 1oC / 150 hours
- operating life: > 500 hours
- insensitivity to press: 0 to 750 psi with < 1oC error
- operating frequency: 100 MHz to 1 GHz
- sampling rate: 1 Hz to 100 kHz
- rotation: up to 53,000g's



5.4 “Passive Direct-write Sensors”

Mike Newton – nScript- mNewton@nscriptinc.com - www.nscriptinc.com

Printed Electronics + 3D Additive Manufacturing = Direct Print Additive Manufacturing

Print what you can....place what you can't.

Micro-Dispensing/direct printing:

- High speed
- As fast as 500mm/sec.
- Wide range of material choice:
- Viscosity from 1cps to >1 million cps.
- Many Types of materials
- Capability of high resolution and accuracy
- Pico-liter level column control
- Line as small as 20um, dot as small as 75um.

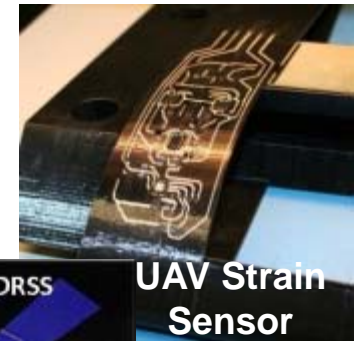
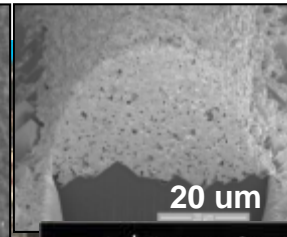
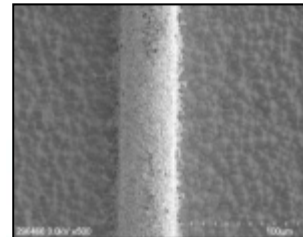

UAV Strain Sensor



Metal loaded Silicone

Applications:

- 2nd Generation TDRSS
- Print and Play Monolithic Satellite
- UAV monolithic strain sensor
- Magnetometer
- Vibration Sensor
- Electronic Circuits
- Solar Cell Mfg
- Metal loaded silicone
- **Passive Wireless Sensors??**

3D Print n Play Monolithic Satellite

Mixture, by volume:
25% DSM Somos 11122
75% Ceramic powder

Syringe for Loading, mixing, storing, dispensing

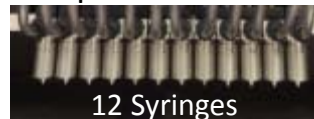

12 Syringes



Solar Cells

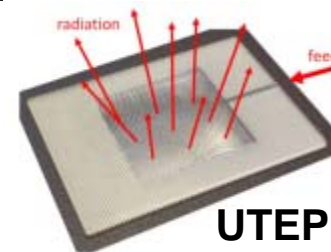

UTEP Antenna



USF

6.1 “Advances in SAW Devices for Sensing and RFID Applications”

Paul Hartman – RFSAW Inc. - phartmann@rfsaw.com - www.rfsaw.com

Global SAW Tag (GST) - SAW-based passive RFID – 2.44GHz

- Longest passive sensor reading range
- HERO certified for safe use on munitions
- Anti-Collision Matched Filter Processing
- Temperature tolerant Codes with Cross-correlation (i.e. anti-collision)
- Range-dependent zones – group similar tag response magnitudes using times of arrival

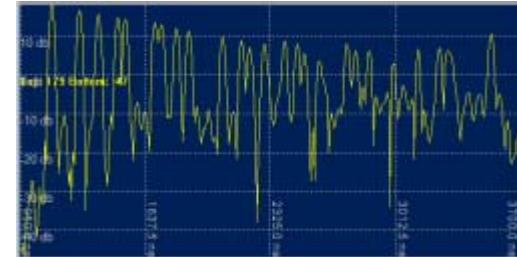

Actual 96-Bit Wireless Tag Waveform

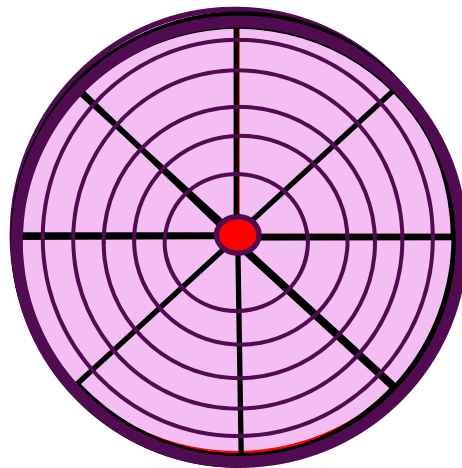

Potentially 240 SAW Temperature Tags:

- 5 Codes
- 6 Ranges
- 8 Directions(Antennas)
- Reader switches from one antenna to the next



8 Port Reader

6.2 “PWST SAW - Sensor System”

Jackie Hines – VP ASRDC Corp. jhines@asrdcorp.com - www.asrdcorp.com/
Applied Sensor Research & Development Corporation

Wireless SAW Sensor Advantages:

Operate wirelessly RFID capable
RF signal activates sensor,
Require no batteries Sensitive/accurate
Perform multiple real-time measurements
Last a long time (decades)
Survive & operate in extreme environments
Cryo to 1,000°C RadHard to > 10 MRad
Low cost
Established technology
High Volume - Billions of devices sold/year for cell phones
=> **Enable low cost distributed sensing**

SAW Sensors under development @ ASRDC

- Coded sensor-tag wireless interface devices
 - use variable impedance input from Std sensors
- Humidity - Today's Focus
- Hydrogen
- Temperature
- Methane
- Hypergol leak detection(MMH, DMH, NTO)
- (Cryogenic) liquid (level)
- Concrete maturity monitor
- Biosensor for infectious agents (CT)

Passive Wireless SAW Humidity Sensor System

 - Temple developed quick response sensor from Nanoparticle PVP/LiCl-doped TiO₂ films

DSSS codes with time, frequency diversity – 32 T sensors
Discrete Frequency Coding (DFC) – 8 good codes

Time Diversity - Re-used each code at eight distinct time delays

Orthogonal chips at each freq. have different delays to produce codes

Similar to OFC, but with code “chips” in frequency bands that do not overlap

Relative Humidity measured, need to add temperature compensation

System Delivered to NASA KSC, making improvements – deliver Nov 2012

Advances in Sensor-tag Coding

13-bit Barker code with time & frequency diversity – 100 sensor-tags

DSSS codes with time, frequency diversity – 32 T sensors

SBIR Phase 2 Temperature Sensor System(32) to NASA/MSFC – 2013

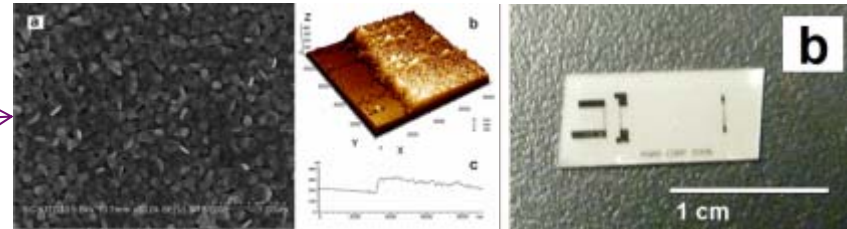

-Time integrating correlator-based Transceiver
-Power spectral density of response measured
half-passband integrated energy

6.3 “SAW PWST: 915 Mhz Sensor System and Demonstrations”

Don Malocha – Univ of Central Florida - malocha@mail.ucf.edu

UCF Progress:			2 dBi antenna Isotropic Range (m)	Data Transfer Rate (sec)	Post Processing Rate (msec)/sensor	Plotting and Overhead (sec)
Year	Hardware	# Sensors				
2008	UCF	1-2	< 1	5	>1000	2
2009	UCF	1-2	1-3	2	>1000	2
2010	UCF & MNI	1-4	1-4	0.5	500	2
2011	MNI	1-6	1-5	0.5	100	2
2012	MNI	1-8	1-7	0.5	10	2
2013	MNI and ?	1-16	1-10	0.5	5	?
2014	MNI and ?	1-32	1-50	0.001	1	?

Acknowledgements

NASA/KSC Dr. Bob Youngquist
 Florida High Tech Corridor Council
 Florida Space Institute
 Mnemonics(MNI)

Orthogonal SAW Frequency Coding(OFC):

- Frequency & time offer great coding diversity
- Single communication platform for diverse sensor embodiments
- Spread spectrum

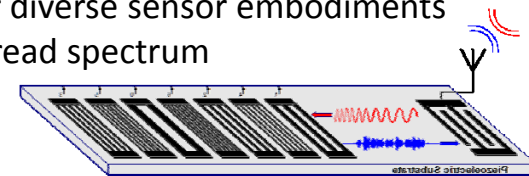

Sensors: temperature, range, strain, hydrogen, magnetic, liquid, cryogenic

Environments: isotropic, hallways (60m), faraday cage (.5x.5 m), anechoic

UCF Fast Prototyping <1 week from idea to device prototype

RF Transciever – more parts are making it faster and cheaper to develop

UCF Correlator Synchronous Transceiver- Software Radio (2004-2010)

- Pulse Interrogation: Chirp or RF burst
- Integration of multiple “pings” OFC processing gain
- 915 MHz sync transceiver(Mnemonics, Inc) to NASA/KSC – STTR

Dual Track Gas Sensor: (On-board Sensor) Ref to left and thin film sensor to right)

Magnetic Puck for Closure switch sensor (On-board)

Antenna used as Closure sensors (Off-board)

Matched Filters to reduce noise, Correlator Time Delay Extraction(CTDE)

- S/N determines the precision and accuracy

Adaptive Temperature Correlator

Range: Current: 5meters; Future: 250m – 800m

High Temperature SAW devices on Langatate (LGT) - stable up to ~1450°C

- Platinum thin/thick films under investigation

Sawtenna development

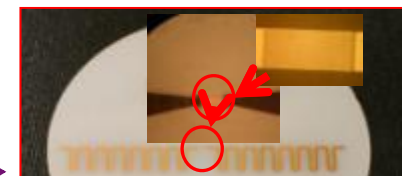
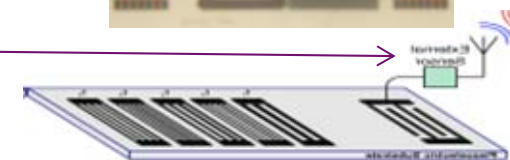
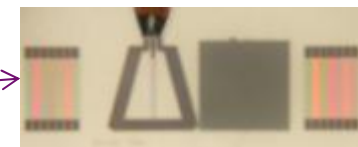
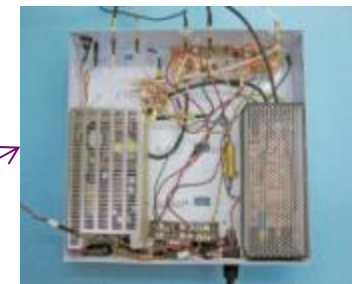

7.1 “SAW Sensors: Explore New Measurement Horizons”

Heimo Mueller – CTR Carinthian Tech Research, Villach, Austria - heimo.mueller@CTR.at – www.ctr.at

Wireless SAW Sensor Symposium, Villach, Sep 20 & 21, 2012 www.saw-symposium.com

➤ CTR SAW System Sensor-Tags

Temp	C	F
Range	-55°C to +400°C	-67°F to +752°F
Accuracy	±2°C	±3.6°F
Resolution	0.1°C	0.18°F
Read range	Meters	Feet
9 dBi antenna	up to 2m	up to 6.6ft
18 dBi antenna	up to 4.5m	up to 14.8ft



Readers



	Standard	Fast	Handheld
Read Time	300msec	100µsec	100msec
Channels	4	1	1
Frequency Bandwidth	2,45 GHz 80 MHz	2,45 GHz 80 MHz	2,45 GHz 80 MHz
Interface	LAN	LAN	Bluetooth
Power Source	EN 300440, FFC Part 15, JP	EN 300440	Battery life > 10.000 reads

➤ SAW Applications

- Automotive: Pressure, Varnish lines
- Food: Baking Plates – ID, Temp & Pressure
- Oil: Drill Pipe – ID - www.hmenergyllc.com
- Steel – Slag Vessels, Slide Gate Plates – ID
 - Refrac Drying & Mold Temps
- Energy – Transmission Line Temps



Software: Visualizer

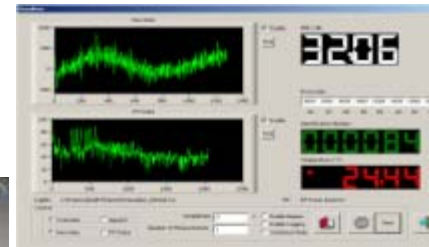

Panel



CTR SAW R & D

Beam-based 7 Membrane-based pressure
Strain - Tensile & Lateral strain

- Temperature compensation

High Temp - 600°C (1112°F) working temp 28

- 800°C (1472°F) short term

Housings: Ceramic & Metal housing needs

Rotating Machine Elements – Temps



Trying:
Al Nitride
thin film on
Sapphire
1100°C
(2012°F)

7.2 “Vectron Wireless Temperature Monitoring Solutions

Sabah Sabah – Vectron-Sengenuity - sabah@sengenuity.com – www.sengenuity.com

Single SAW Resonator: Absolute Measurement

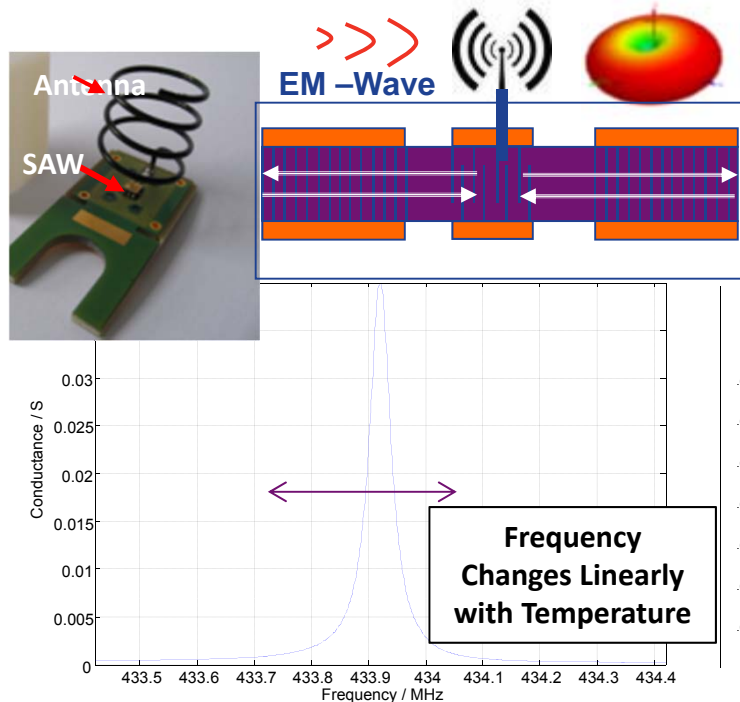

Double SAW Resonator: Differential Measurement

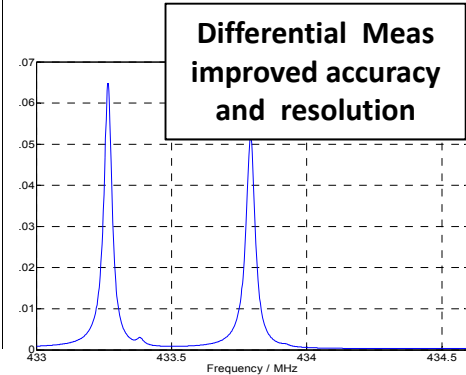
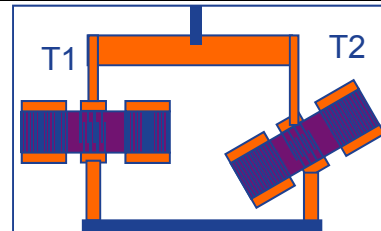

- **Passive and Wireless**, non-invasive and no active electronic circuits
 - Save 20%-80% of industrial wire installation costs (est. US \$130 – \$650 /m)
- **Medium & High** temperature operating ranges: -20°C to 120°C & up to +260°C
- **Reading Distance:** 0.1 to 3 Meters (depend on the antenna and RF environment)
- **System accuracy:** ± 2°C (temperature operating range -20°C to 120°C)
- **Robust, reliable, stable and suitable for harsh**, hazard and inaccessible hot-spots
- **Multi- Communication Protocol:** RS485, RS232, USB, CAN. Analog-Output, MODBUS
- **User Friendly**, ease of installation, simple to use Interfaces and data logging
- **Real-Time** and Continuously Thermal Monitoring – 24/7/365
- **Miniature:** small and light, low cost
- **Low Maintenances**
- **Low ageing degradations** (± 2°C <12 years)
- **Environmental** and green technology – no recycling of battery

Applications:
 Switching Temps for Smart Grid
 Food Thermometer
 Rotating Equipment Temps
 Tire pressure
 Fluid Viscosity

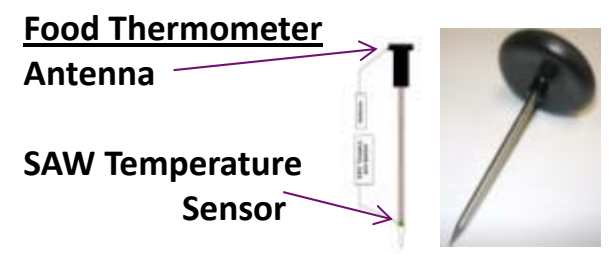

7.3 “RFID Tag Antenna-Based Sensing”

Isaac Ehrenberg – MIT Auto-ID Labs - yitzi@mit.edu; Rahul Bhattacharyya - rahul_b@mit.edu
 Prof Sanjay Sarma

➤ Keeping Tabs on Things:

KSW semi-passive RFID temperature logger (>\$3)
www.variosens.com



➤ Why RFID?

- Proven track record of pervasive deployment
- Low cost RFID tag manufacturing
- Standardized reader-tag communication
- Free adoption in RFID-enabled processes

Applications:

- Temperature: perishables in cold chain
- Temperature, Humidity and Shock on large scale

➤ 2 Concepts:

Use Reader-Tag Signal Parameters for Sensing

AM: Use Reader Power or Tag Backscatter

FM: Use Freq shift in Tag Response

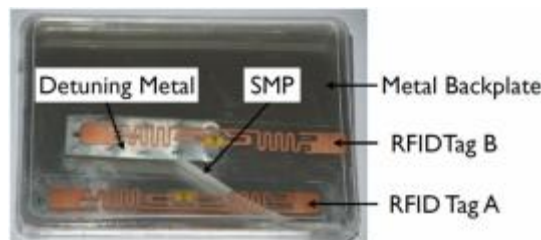

- Temperature Threshold Sensor
- Fluid Level Sensor

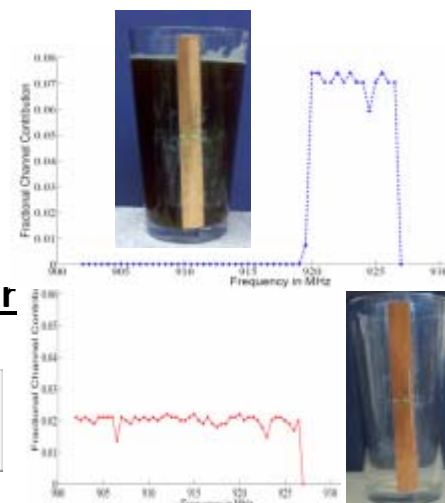

Low-cost, non-electric Memory

Normally, Passive RFID Tags can't record events when unpowered

- Permanent Change to Antenna(e.g. damage) = memory - Temp Threshold Sensor

- Temporary Change: Shape Memory Polymers – Glass Transition Temp – flexible vs rigid
- Diaphragm or Antenna Detuning metal – changes Tag Backscatter (AM)
- Fluid in a glass(Deavors 2010)

Note: Other Inventions Potyrailo 2010, Siden 2007, Caizzone 2011

8.1 “Passive UWB: Long Range, Low Cost and Precise Location”

Kouros Pahlavan – TagArray - kouros@tagarray.com www.tagarray.com

Motivation:

- Cost Effective: Total cost of ownership 100x less than GEN2 or active RTLS
- Zero Watt Passive Transceiver: Tag consumes $< 2\mu\text{W}$ when communicating
- Accurate Location and Long Range: 2-3 inch resolution from 100 meters away

How it Works:

1. Beacon is a Narrowband UHF Transmitter
2. Narrowband signal powers Tag, initiates query session - 4W EIRP: 10m range
3. Receiver harvests RF power and wakes up
4. Tag transmits UWB impulses - 6dBm: 50-100m range
5. UWB Receiver(Single Chip/ Very Low Cost) uses Digital Antenna

Advantages:

- Small Cost & Size: UWB Readers are 100x and 20 times smaller than Gen2
- Read Range: 50-100 meters
- Resolution: 2-3 inches
- Sample Rate: 1000s of reads per second per reader
- Multi-path Immunity:
 - Robust tag detection/location determination
 - Signal propagates through openings and cracks
- Low Power: Tag chip consumes ave of $2\mu\text{W}$ (memory incl)
 - Alt power options: micro solar cell, MEMS harvesters, etc.

Status:

- Available: Tag, Reader and Software
- Next: Increase DA sensitivity to achieve 100m range
- Tag Antenna, Reader, Software for many tags, FCC cert

Applications:

- RTLS & Indoor tracking
- RFID
- Sensors
- Surveillance

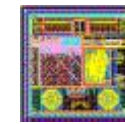

Tag 1mm x 1mm

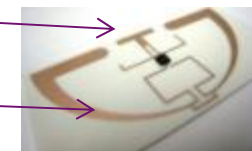

UWB Ant

UHF Ant

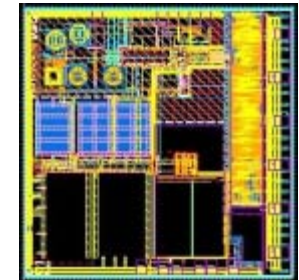

Reader 1mm x 1mm

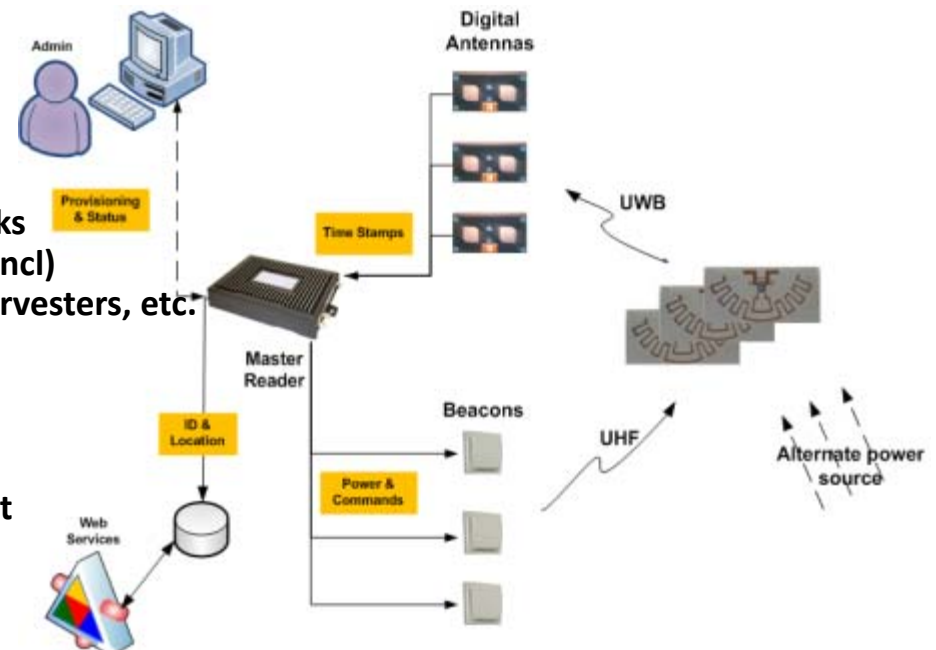

8.2 “60 GHz Comm, RFID - moving to Passive Sensors”

Don Kimball – Maxentric - dkimball@maxentric.com www.maxentric.com

ViFi- V-band wireless Fixed and Mesh Network

- Unlicensed at 59-64 GHz in many countries
- Low SWaP at high freq
- Directional Antenna

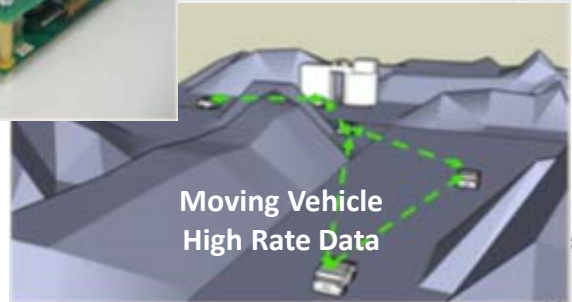
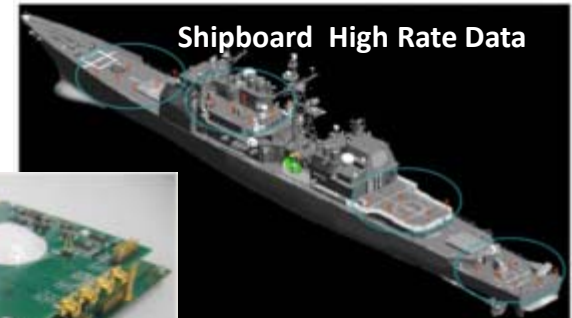

- Highly Reflective inside metallic enclosures like spacecraft
 - Order of magnitude better than 2.4GHz in satisfying HERO (Hazards of Electromagnetic Radiation to Ordnance)
 - Security: atmospheric resonance attenuates signal beyond 100-300 ft
- Mesh Network: Ad-hoc Mesh, High Data Rate(>Gbps), Delay Tolerant (Memory-based), Ethernet Compliant
- 1.3 Gbps and adjustable to 10 Mbps

VERSA - V-band Enhanced RFID/Sensing

- Thin metal dipoles called Taggants – tiny for high freq
- Tag-response based on: Taggant orientation & Relative positions
- Temperature, Pressure, Voltage, Location & Orientation

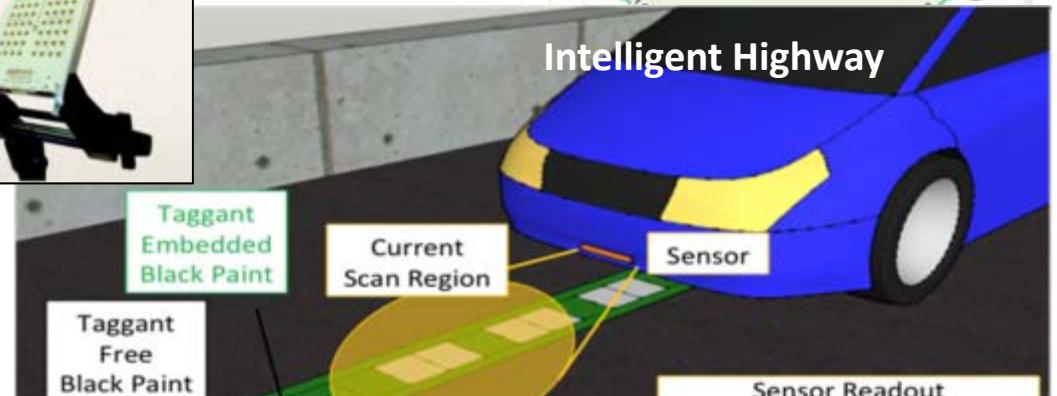
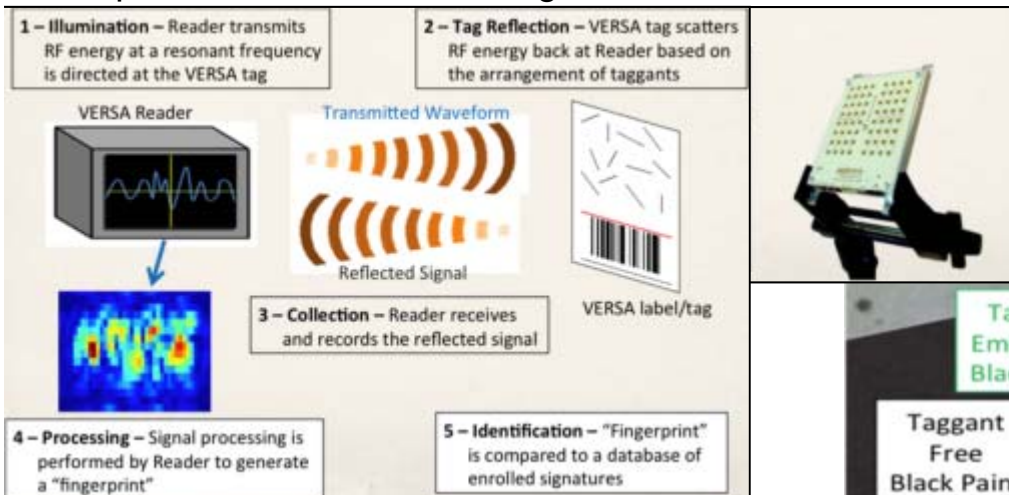

8.3 “Wireless Temperature Sensors for Gas Turbine Engines”

John Conkle - Wireless Sensor Technologies - jrconkle@att.net

Problem:

- Catastrophic Failure caused by degradation and damage to hot section components
- Poor characterization of degradation process affects the development of durable components

Users:

Jet Engine Developers, Users, Maintenance

Other harsh environment applications - control and CBM applications in carbon, steam, or nuclear-fueled power plants.

Requirements:

- Accurate temperature measurement
 - 10° C accuracy, Range of -60 to 1300C
- Long-term reliability
 - ‘00’s of hours for developmental testing
 - “000’s of hours for PHM and CBM application
- Easily mount on turbine blade or target surface
- Not alter the blade dynamics (weight, gas flow)
 - “Massless” and “Zero” height

WST Solution:

- Sensor Printed like an IC out of Alumina
- Antenna,
- Ceramic Dielectric, AZO Schottky Diode
- TRL5 in Fall 2012

In-Engine temperature surface data critical for:

- Propulsion Health Monitoring (PHM)
- Condition-based Maintenance (CBM) that has been mandated for use by the DoD
- Developmental testing of new engine designs

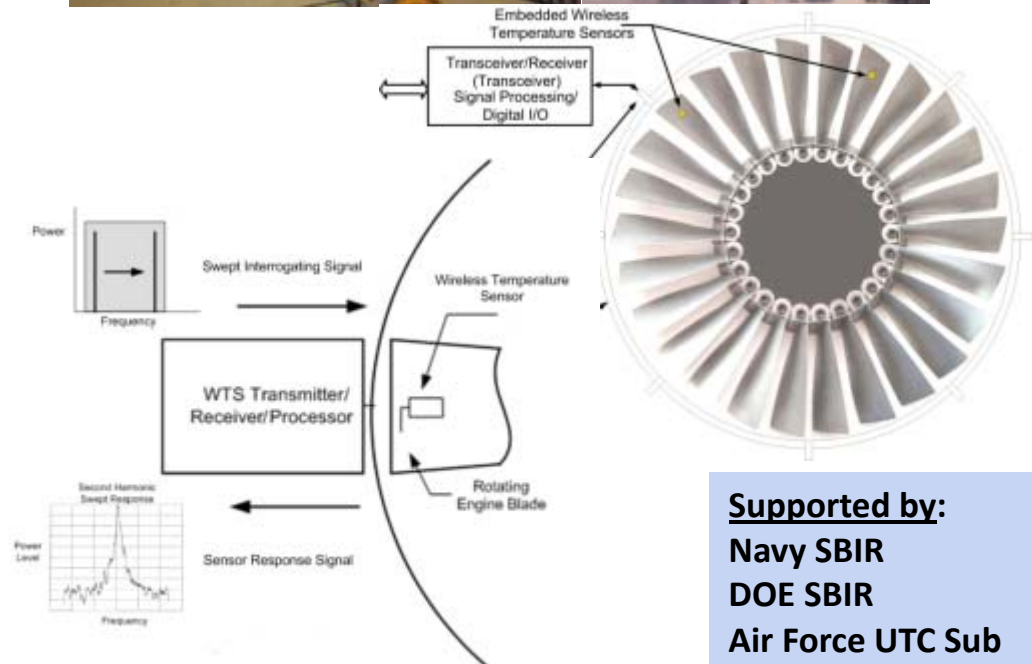

Supported by:

Navy SBIR
DOE SBIR
Air Force UTC Sub

8.4 “A System Engineering Simulation Tool and Data Base Proposal for Optimizing the Application of Wireless Sensors”

Scott Hyde – Aerojet - Scott.Hyde@Aerojet.com www.aerojet.com

Machine-to-Machine (M2M) Market Lesson’s Learned

- M2M communications consists of using a device to capture an “event” relayed through a network to an application, translating the captured event into meaningful information.
- Similar problems to Aerospace: too much to communicate, systems are inflexible, system cost

<http://www.machinetomachinemagazine.com>

Power of Simulation and its Role with Wireless Sensing

Simulation Reduces Upfront Costs and Pays Off Through the Systems Life-Cycle by Facilitating Assessment of Change Requirements, Impacts Due to Obsolescence and Software/Hardware Upgrades

Elements of a System Architecture can be Simulated with High Fidelity Enabling Management of System Complexity and Communication Congestion – Physical Level, Logical Level, System Level

CPIAC Sensor Database :

- Chemical Propulsion Information Analysis Center (CPIAC) is developing a secure, online, portal for the collaborative collection and dissemination of sensor related information.
- Access has ITAR restrictions (U.S. Citizens only)
- Sponsors: NASA , US Air Force and US Department of Energy
- CPIAC to Design, Implement and Host/Maintain an Online Tool for JANNAF to:
 - Allow the secure exchange and collection of information on sensors
 - Wiki-like functionality: Users create new entries based on standard forms
 - Documents can be attached as references for each sensor
 - Search capability based on keywords or filtering by criteria
 - Data reviewed prior to posting by an approving authority
 - CPIAC to perform initial data population using NASA sensors database

Include
Active and Passive
Wireless Sensors?

Add an ISA or other
External database to
complement it?

Potential Future Areas of Emphasis

Next Workshop 2013?

Technology Developers

- Progress in Technology and Applications since 2011/2012 Workshops
- Near Field Communications
- Manufacturing Advances
- Embedded sensing and Nano-materials
- Hybrid Systems
- Systems Integration
- International Developers

End User/Stakeholder Needs

- Consumer Products
- Aerospace
- DOD and Security
- Energy, Efficiency and Environments
- Automation and Machine-to-Machine Interfaces
- Health Monitoring
- Test Instrumentation
- Facility and Vehicle Architecture Changes

Coordination:

- Communication
- Research and Education
- Community of Practice
- System and User Needs Data Base

Comments – Questions?

**George Studor
NASA/Johnson Space Center
Structural Engineering Division
(763) 208-9283
George.F.Studor@nasa.gov**