



US008313870B2

(12) **United States Patent**
Pien et al.

(10) **Patent No.:** **US 8,313,870 B2**
(45) **Date of Patent:** **Nov. 20, 2012**

(54) **INTEGRATED FLOW FIELD (IFF) STRUCTURE**

(75) Inventors: **Shyhing M. Pien**, Acton, MA (US);
Marvin Warshay, Shaker Heights, OH (US)

(73) Assignee: **ElectroChem, Inc.**, Woburn, MA (US)

(*) Notice: Subject to any disclaimer, the term of this patent is extended or adjusted under 35 U.S.C. 154(b) by 967 days.

(21) Appl. No.: **12/262,975**

(22) Filed: **Oct. 31, 2008**

(65) **Prior Publication Data**
US 2009/0136789 A1 May 28, 2009

Related U.S. Application Data

(60) Provisional application No. 60/984,097, filed on Oct. 31, 2007.

(51) **Int. Cl.**
H01M 8/04 (2006.01)

(52) **U.S. Cl.** **429/429**; 429/428; 429/400

(58) **Field of Classification Search** 429/429
See application file for complete search history.

(56) **References Cited**

U.S. PATENT DOCUMENTS

5,322,744	A	6/1994	Koseki et al.	
5,641,586	A	6/1997	Wilson	
5,840,414	A	11/1998	Bett et al.	
6,197,442	B1	3/2001	Gorman	
2005/0208366	A1	9/2005	Rohwer et al.	
2006/0199061	A1*	9/2006	Fiebig et al.	429/32
2006/0286429	A1	12/2006	Shiepe et al.	

FOREIGN PATENT DOCUMENTS

KR	10-2007-0023219	2/2007
WO	WO-03/058743	7/2003

OTHER PUBLICATIONS

International Search Report dated Jul. 29, 2009 from PCT/US2008/082099.

* cited by examiner

Primary Examiner — Raymond Alejandro

Assistant Examiner — Gary Harris

(74) *Attorney, Agent, or Firm* — Foley Hoag LLP

(57) **ABSTRACT**

The present disclosure relates in part to a flow field structure comprising a hydrophilic part and a hydrophobic part communicably attached to each other via a connecting interface. The present disclosure further relates to electrochemical cells comprising the aforementioned flow fields.

15 Claims, 8 Drawing Sheets

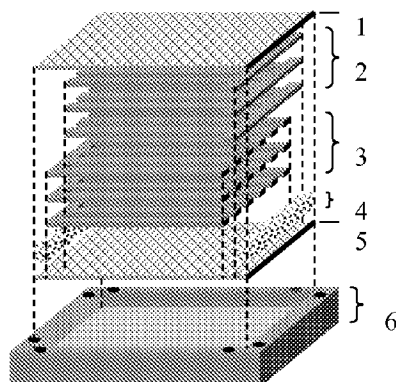
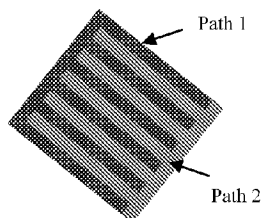

Figure 1

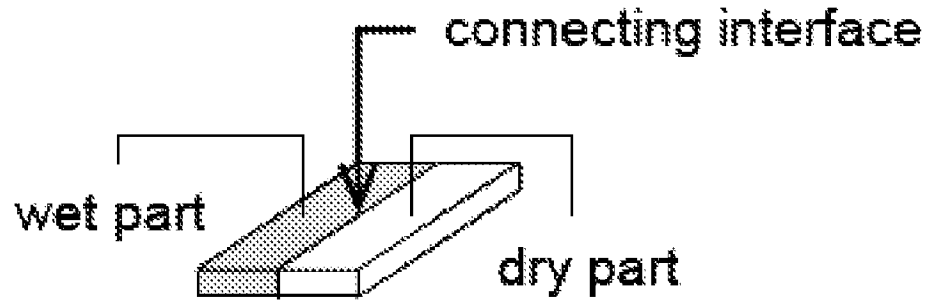

Figure 2

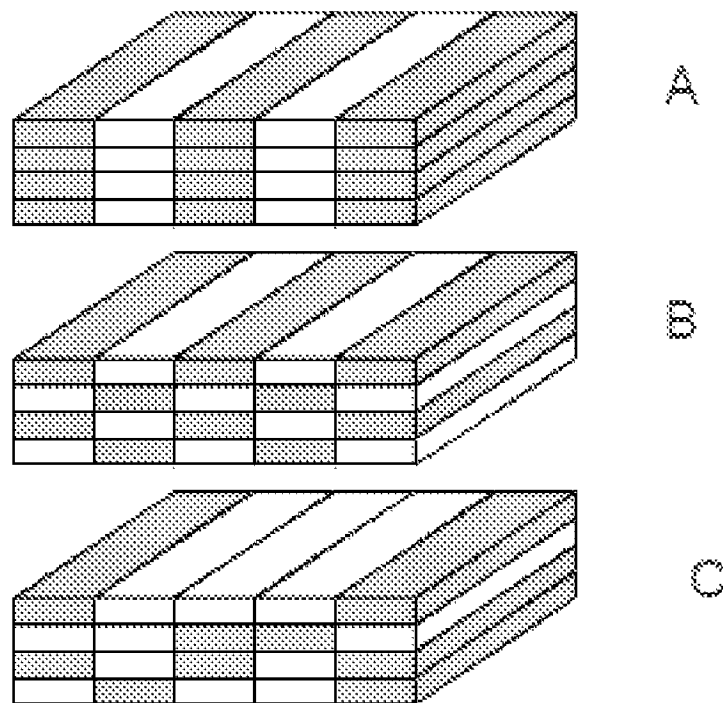

Figure 3

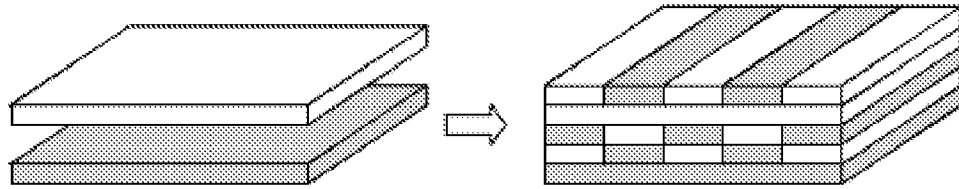

Figure 4

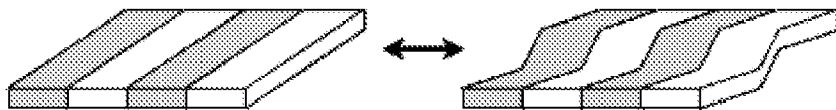

Figure 5

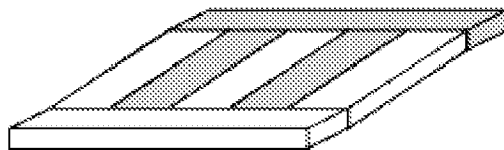

Figure 6

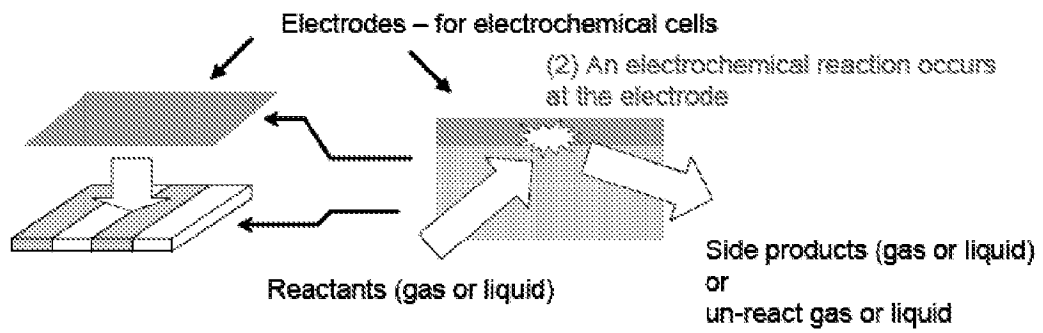

Figure 7

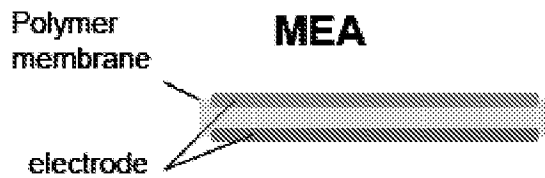

Figure 8

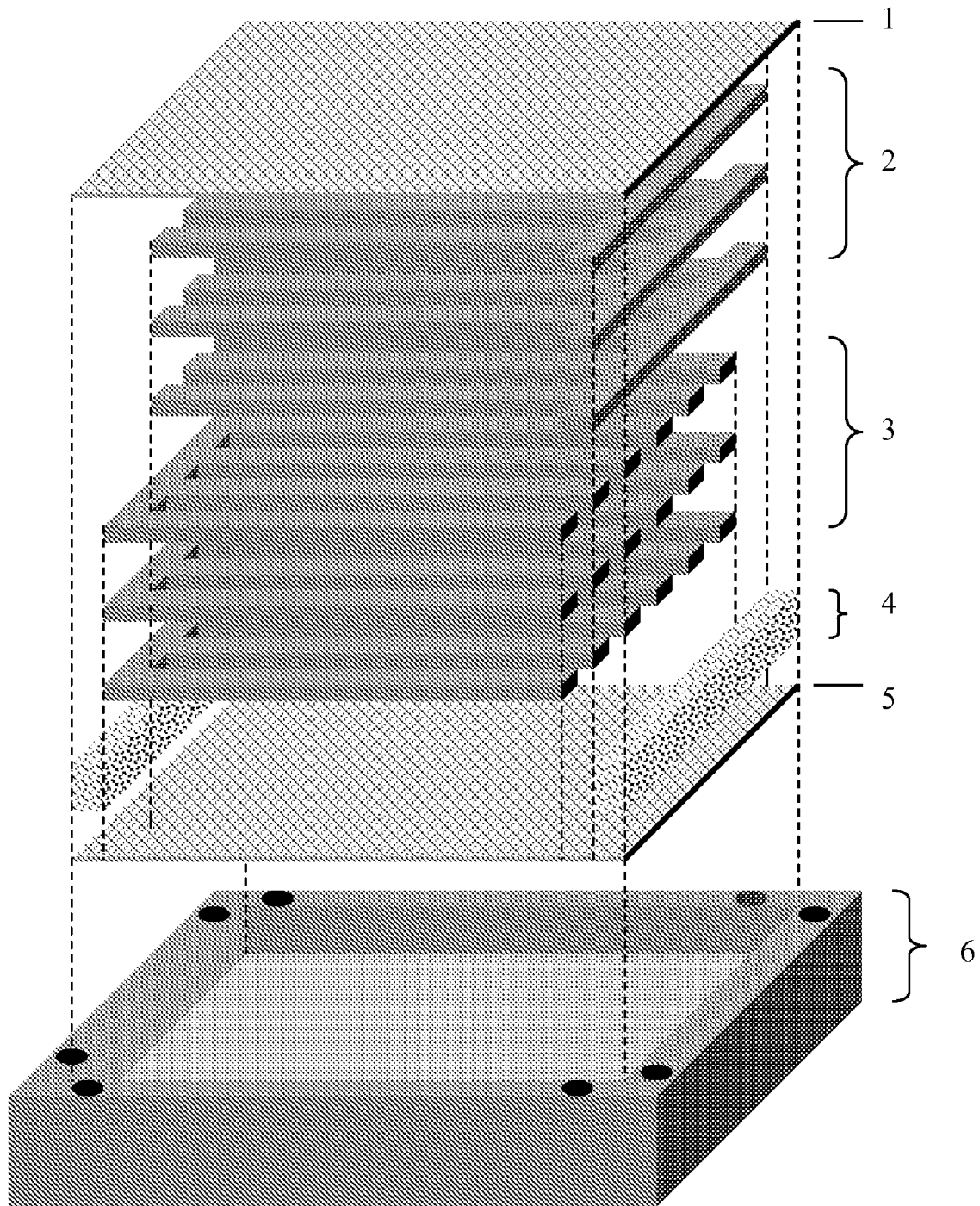

Figure 9

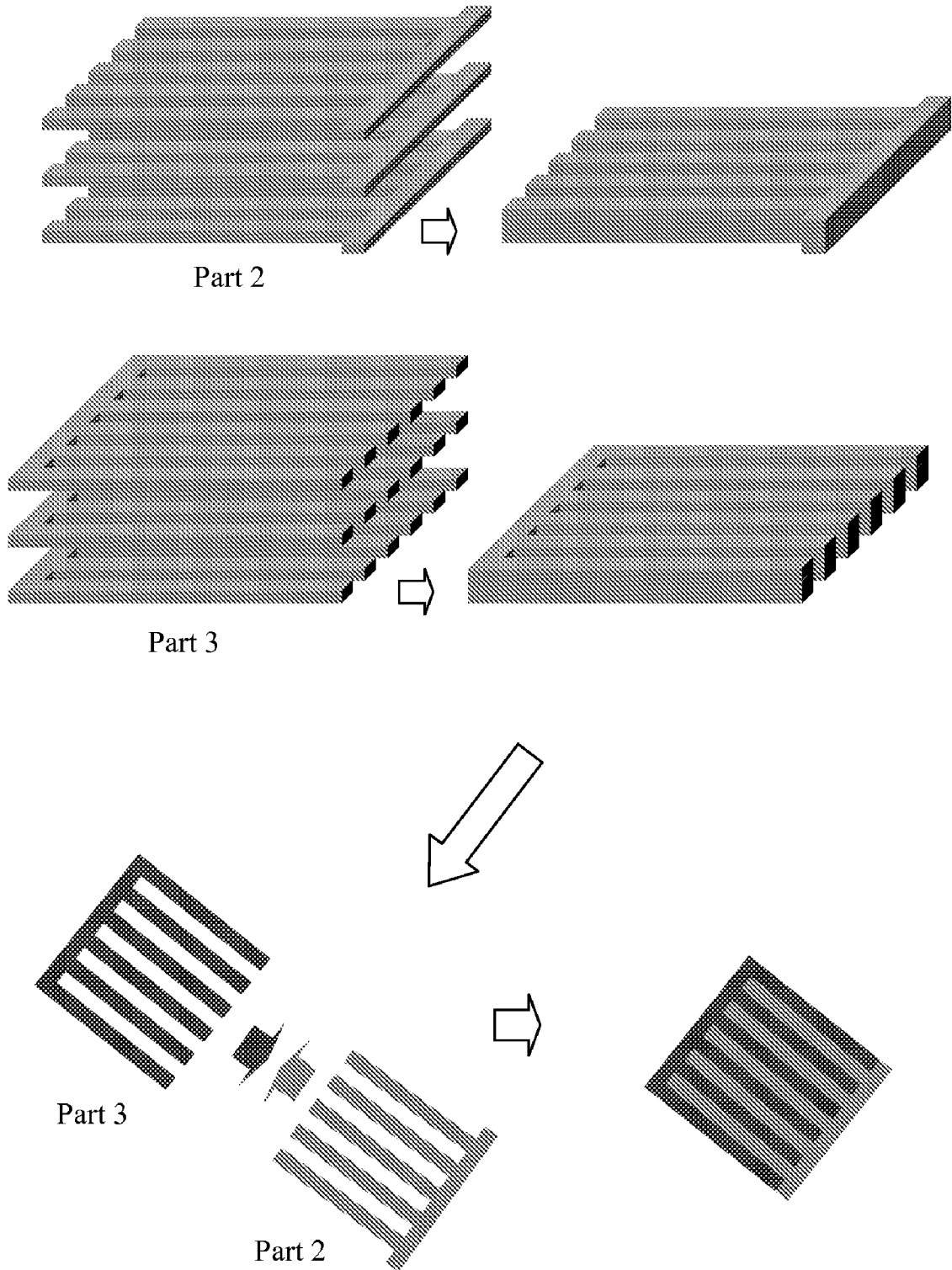

Figure 10

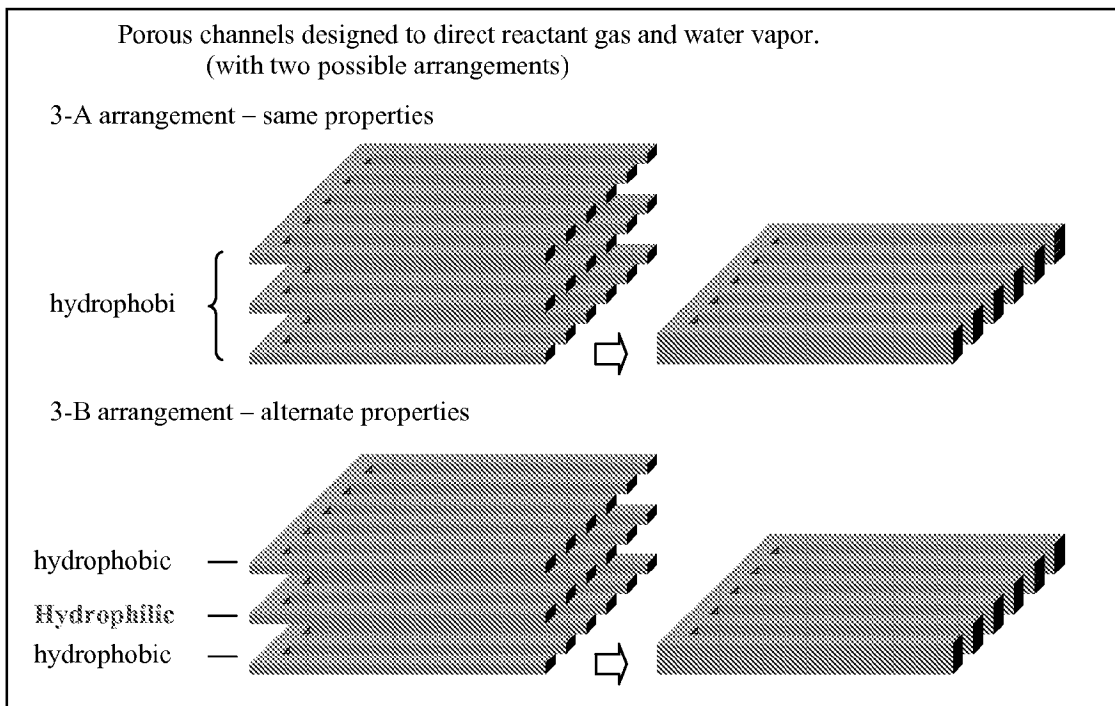
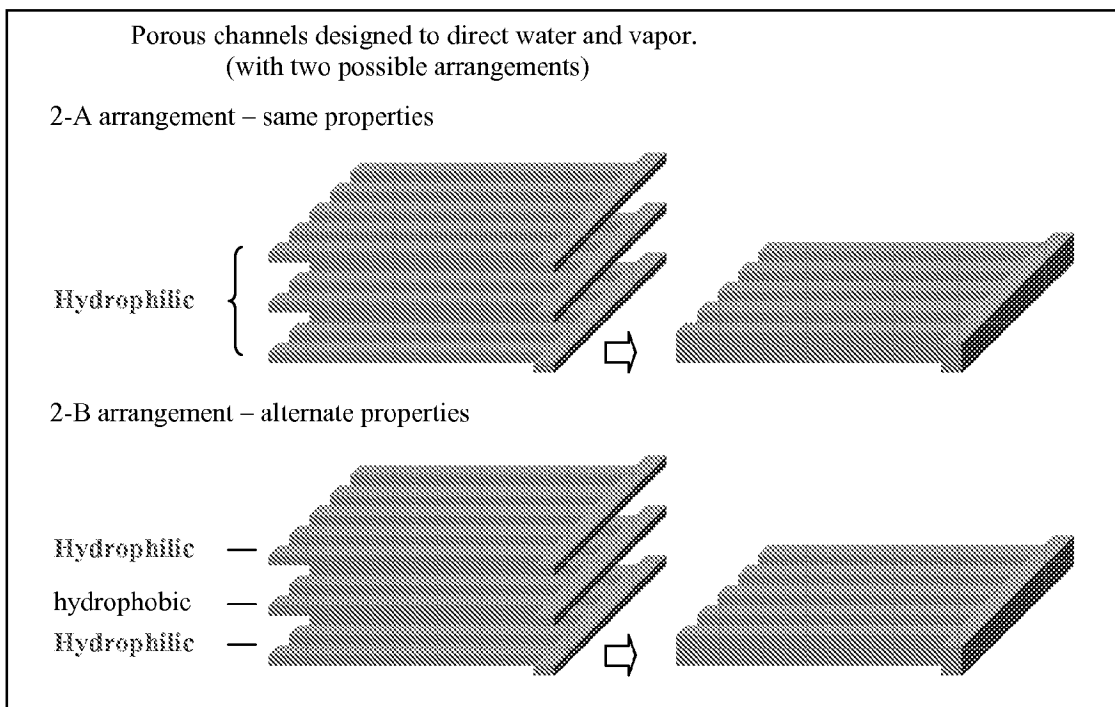

Figure 11

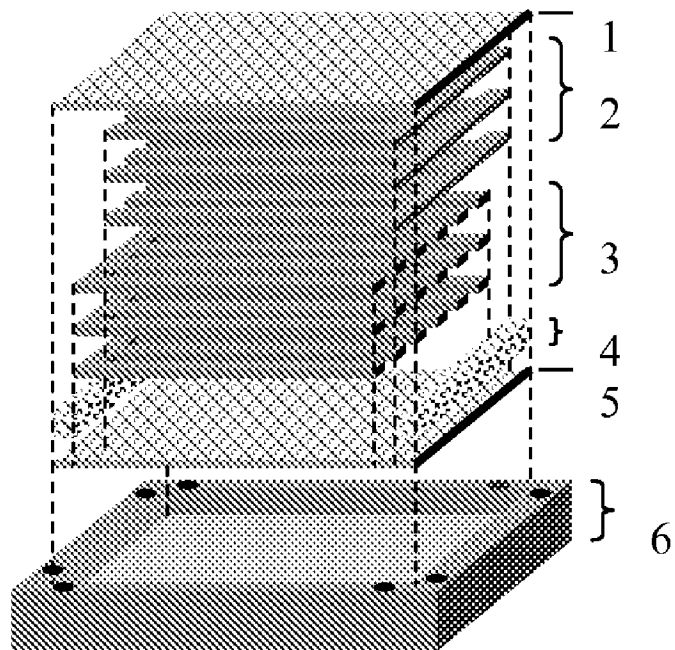
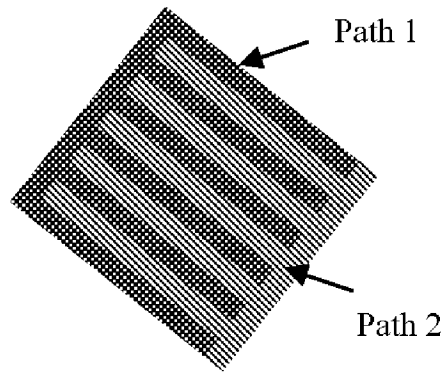
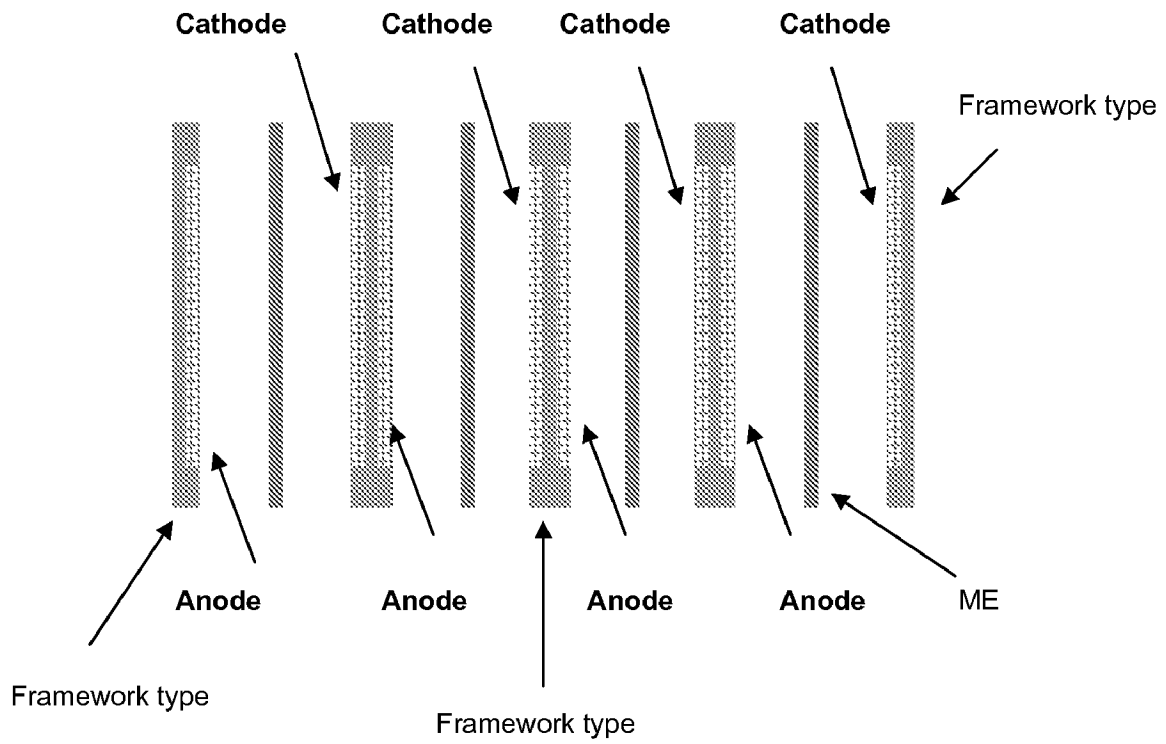

Figure 12



1

INTEGRATED FLOW FIELD (IFF) STRUCTURE

RELATED APPLICATIONS

This application claims the benefit of priority to U.S. Provisional Patent Application No. 60/984,097, filed on Oct. 31, 2007, which is herein incorporated by reference in its entirety.

GOVERNMENT SUPPORT

This invention was made with Government support under NASA SBIR Contract Nos. NNNJ06JD71C and NNNJ07A10C awarded by the National Aeronautics and Space Administration (NASA). The Government may have certain rights in the subject invention.

BACKGROUND

A flow field is a configuration that is specifically designed to distribute gas, liquid, vapor, or a combination thereof. A flow field is usually confined inside a compartment, and the compartment defines the boundary of the flow field and provides one or more access points to the flow field for the introduction of reactants and removal of byproducts. Flow fields are often used in connection with electrochemical cells.

Electrochemical cells operate by reacting with the reactants and producing electrons generating current and potential. A typical electrochemical cell consists of electrodes separated by a layer of electrolyte. The electrodes can be defined as anode and cathode electrodes or working and counter electrodes. A separate reference electrode can also introduce to the electrochemical cell. Gas that comes in contact with the electrodes first passes through an opening flow field (or channels) then diffuses through a barrier of the electrode and eventually reacts at the surface of the electrode involving either an oxidation or reduction reaction mechanism. These reactions are catalyzed by the electrode materials specifically developed for the reactants of interest.

For example, an electrochemical fuel cell specific to hydrogen and oxygen has an anode and cathode electrodes. The anode electrode produces electrons and protons for the oxidation of hydrogen at the anode. During a simultaneous reduction of the cathode, the electrons generated at the anode release and travel via an external circuit to the cathode where oxygen molecules consume the electrons (reduced) and form water by further combining the protons which travel via the electrolyte layer. The electrochemical fuel cell has been developed to convert fuel (hydrogen, alcohols such as methanol or ethanol, hydrocarbon, carbon oxides) and oxidant (such as oxygen, air) to generate electric energy; in other words, they convert the free energy of reaction of a fuel with an oxidant without degrading it completely to thermal energy. This conversion is achieved through the electrochemical oxidation of the fuel at the anode, with the consequent release of electrons and protons, while the oxidant is reduced at the cathode. The migration of the protons from the anode to the cathode compartment of the cell takes place through a suitable electrolyte.

When a solid polymer electrolyte is applied in electrochemical cells, such as polymer electrolyte membrane fuel cells (PEM fuel cells), the integration of the anode electrode, cathode electrode and electrolyte layer forms a membrane electrode assembly (MEA). Oxidation and reduction reaction occurred at the electrodes. The formed protons permeate

2

through the polymer electrolyte membrane. The formed electrons travel along an external load circuit to create the current output of the fuel cell.

In a reverse process, electrolysis, which is commonly carried out in an electrolyzer, the liquid water (e.g., the product of the fuel cell) is converted back to the reactant gases (e.g., hydrogen and oxygen useable by the fuel cell). When the fuel cell and electrolyzer are operated in concert as two separate electrochemical cells or as a single electrochemical energy storage unit it is commonly called a regenerative fuel cell ("RFC"). Furthermore, a single electrochemical energy storage unit is commonly called a Unitized RFC to indicate that both the fuel cell process and the electrolysis process are carried out during different cycles within a single electrochemical cell.

Fuel cells utilizing a polymer electrolyte membrane (PEM) are typically configured in cell stacks having separator plates between adjacent membrane electrolyte assemblies (MEAs). On each side of the polymer electrolyte membrane, there is an electrode. One side is the anode electrode and another side is the cathode electrode. The separator plates and polymer electrolyte membranes keep the reactants separated between the anode and cathode of the electrochemical fuel cells. Flow fields (that are usually part of the separator plates) direct the reactants to the electrodes. The flow fields also direct the products out of the cells.

Fuel cells are considered to be an excellent alternative to the traditional systems of electric generation, mostly due to the extremely favorable environmental impact (absence of noxious emissions and noise, release of water as by-product). They can be used both in the field of stationary power generation of various size (electric plants, continuity or emergency power generators, etc.) as well as in the field of mobile applications (electric automotive applications, generation of automotive energy or auxiliary energy for space, submarine and naval applications).

Electrochemical cells, such as fuel cells and electrolyzers, have inherent problems associated with the changes of phase that occur in the cell when, upon reaction, gaseous reactants are converted to water or water vapor (in fuel cells) or the reactant water to oxygen and hydrogen gases (in electrolyzers). After some of the reactants have been converted to product, they must be directed away from the electrode catalytic reaction sites to avoid blocking access to these sites to the unreacted reactants. The undesirable condition called "flooding" can occur when product water blocks reactant access to the electrode catalytic reaction sites. The undesirable condition called "dryout" can occur in the electrolyte layer when large amounts of dry reactant gas are introduced in the fuel cell. Thus, water management in fuel cells is complicated by two seemingly conflicting requirements associated with two vital elements of the system: the proton exchange membrane must be kept sufficiently hydrated in order to avoid dry out effectively conduct protons. At the same time, the catalytic sites on which the two half-reactions take place must be continuously supplied with gaseous reactants and kept relatively dry in order to efficiently proceed with the catalytic reaction.

Flow fields are used in electrochemical cells to attempt to resolve some of these issues, but with certain drawbacks. Flow fields are typically fabricated in separator plates by machining flow fields into a solid sheet of material or by a molding process. The flow fields are made up of a series of channels or grooves that allow passage of gases and liquids. In order to conduct electrons through the electrochemical cells, these separator plates are typically made of graphitic carbon or a variety of metals. The central portion on the plate

has a flow field machined into its surface. The flow field directs fluid flow across the surface of the electrode in many patterns. Around the perimeter of the flow field, the plate provides various manifolds for communicating fluids through the stack. In addition to usually providing a fluid flow field, a separator plate used in electrochemical cells collects and conducts electrons through contact between electrodes and the ridges, or lands, in the flow field.

In electrolyzer operation, a poor distribution of water reactant to the electrode electrocatalyst site occurs when gaseous product is trapped inside the flow channels. Current flow field designs comprising machined or molded channels in a hard plate, no matter how sophisticated in design, are inherently inefficient in directing the products away from the electrode catalytic reaction sites. Another inherent problem associated with PEM fuel cells is the formation of condensed water droplets in the gas distribution channels, which block gas flow in the channels and can cause severe operational problems, even cell failure, in conventional designs.

In a chemical sensor, proper flow of liquids and gas are needed for accurate detection of the presence of certain chemicals.

Thus, there is a need for a flow field structure, which provides more ideal conditions inside of electrochemical cell.

SUMMARY

Provided herein is an Integrated Flow Field (IFF) structure, comprising a hydrophobic part and a hydrophilic part in communication with each other via a connecting interface. The hydrophobic part and hydrophilic part comprise porous material and have a porosity of 30% to 100%. Preferably, the communication between the hydrophobic and hydrophilic parts is such that a liquid, vapor, a gas, or a mixture thereof, can flow between the hydrophilic and hydrophobic parts. In some embodiments, the flow field structure comprises a plurality of hydrophobic parts and a plurality of hydrophilic parts in communication with each other. In other embodiments the hydrophobic parts and hydrophilic parts are hydrophobic channels and hydrophilic channels, respectively.

In some embodiments, the hydrophobic and hydrophilic channels comprise a porous material, wherein the porous material has a porosity of 30 to 100%.

In some embodiments, the hydrophobic channels and hydrophilic channels are provided in an alternating configuration. In other embodiments, the hydrophobic channels and hydrophilic channels are provided in a random configuration. In still other embodiments, the hydrophobic channels and hydrophilic channels are provided in an interlocking configuration.

In certain embodiments, the number of hydrophobic channels is equal to the number of hydrophilic channels. In other embodiments, the number of hydrophobic channels is greater than the number of hydrophilic channels. In other embodiments, the number of hydrophobic channels is less than the number of hydrophilic channels. In other embodiments, the flow field structure comprises 2 to 20 hydrophilic channels and 2 to 20 hydrophobic channels.

In some embodiments, each channel has a span to width ratio ranging from about 1/2 to about 1/10.

In some embodiments, the hydrophobic part and hydrophilic part comprise graphitic carbon fiber mat, fiber cloth, graphitic carbon paper, sintered metal, metal forms, mesh, screen, reticulated vitreous carbon, or a combination thereof. In other embodiments, the hydrophobic part and hydrophilic part comprise graphitic carbon paper, such as Toray® graphitic carbon. In some embodiments, the hydrophobic part

comprises between about 5% to about 60% Teflon. In other embodiments, the hydrophilic part comprises between about 1 and 60% Nafion.

In some embodiments, the flow field structure further comprises a manifold in communication with the hydrophobic part or the hydrophilic part. In other embodiments, the flow field comprises a manifold in communication with the hydrophobic part and a manifold in communication with the hydrophilic part.

In some embodiments, the flow field structure is provided within a separator plate. In other embodiments, the flow field structure, which may or may not be provided in a separator plate, is provided in an electrochemical cell. The electrochemical cell may be a fuel cell, an electrolyzer, a regenerative fuel cell or a chemical sensor.

In other embodiments, the flow field structure is comprised within a separator plate for a fuel cell stack.

Another aspect of the invention relates to a subassembly for an electrochemical cell, comprising:

- (a) a membrane electrode assembly;
- (b) an electrode gas distribution layer;
- (c) a flow field structure comprising a hydrophobic part and a hydrophilic part in communication with each other via a porous interface;
- (d) a separator plate or frame;
- (e) an input manifold;
- (f) an output manifold;
- (g) a sublayer for humidifying input gas; and
- (h) an impermeable electronic conductive framework.

In other embodiments of the subassembly, the flow field structure is provided in the separator plate or frame. In some embodiments, the sublayer for humidifying gas comprises a porous material.

Another aspect of the invention relates to a fuel cell stack, comprising at least one of the aforementioned subassemblies.

Another aspect of the invention relates to a method for controlling fluid flow in an electrochemical cell comprising:

- a) providing an electrochemical cell comprising a flow field structure comprising a hydrophobic part and a hydrophilic part in communication with each other via a porous interface; an input manifold in communication with the hydrophobic part or the hydrophilic part; and an output manifold in communication with the hydrophobic or the hydrophilic part;
- b) introducing a liquid, vapor, gas, or mixture thereof into the electrochemical cell via the input manifold; and
- c) removing a the liquid, gas, vapor, or mixture thereof from the electrochemical cell via the output manifold.

In some embodiments, the liquid, gas, vapor, or mixture thereof introduced into the cell comprises H₂. In other embodiments, the liquid, gas, vapor, or mixture thereof removed from the electrochemical cell comprises water. In another embodiment the liquid, gas, vapor, or mixture thereof removed from the cell comprises H₂.

Further objectives and advantages of the present invention will become apparent as the description proceeds. To gain a full appreciation of the scope of the present invention, it will be further recognized that various aspects of the present invention can be combined to make desirable embodiments of the invention.

BRIEF DESCRIPTION OF THE DRAWINGS

FIG. 1 depicts an embodiment of a flow field, comprising a hydrophobic part and a hydrophilic part, which is in communication via a connecting interface.