

Oral Presentation/Viewgraphs Summary:

NASA has been involved in the development of Closed Brayton Cycle (CBC) power conversion technology since the 1960's. CBC systems can be coupled to reactor, isotope, or solar heat sources and offer the potential for high efficiency, long life, and scalability to high power. In the 1960's and 1970's, NASA and industry developed the 10 kW Brayton Rotating Unit (BRU) and the 2 kW mini-BRU demonstrating technical feasibility and performance. In the 1980's, a 25 kW CBC Solar Dynamic (SO) power system option was developed for Space Station Freedom and the technology was demonstrated in the 1990's as part of the 2 kW SO Ground Test Demonstration (GTD). Since the early 2000's, NASA has been pursuing CBC technology for space reactor applications. Before it was cancelled, the Jupiter Icy Moons Orbiter (HMO) mission was considering a 100 kW class CBC system coupled to a gas-cooled fission reactor. Currently, CBC technology is being explored for Fission Surface Power (FSP) systems to provide base power on the moon and Mars. These recent activities have resulted in several CBC-related technology development projects including a 50 kW Alternator Test Unit, a 20 kW Dual Brayton Test Loop, a 2 kW Direct Drive Gas Brayton Test Loop, and a 12 kW FSP Power Conversion Unit design.



A Summary of Closed Brayton Cycle Development Activities at NASA

Lee Mason
NASA Glenn Research Center

Supercritical CO₂ Power Cycle Symposium
April 29-30, 2009



Outline

- Space Power Conversion Options
- Closed Brayton Cycle Timeline
- Brayton Development Projects
 - Brayton Rotating Unit & Mini-BRU
 - Solar Dynamic Brayton
 - Brayton Concepts & Studies
 - Jupiter Icy Moons Orbiter
 - 2 kW Brayton Testbed
 - Dual Capstone Brayton Loop
 - Fission Surface Power
 - Direct Drive Gas Brayton
 - Technology Demonstration Unit
 - Full-scale Power Conversion Unit



Space Power Conversion Options



- Closed Brayton Cycle
 - Mature Technology with High Power Potential



- Free-Piston Stirling
 - High Efficiency & Scales Well to Low Power



- Organic or Liquid-Metal Rankine
 - Potential for Low Mass at High Power, but Material & Fluid Mgmt Issues

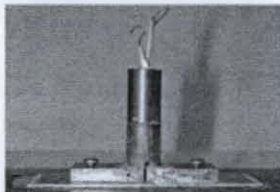

- Thermoelectric
 - Flight Proven with Long Life, but Low Efficiency



- Thermionic
 - Extensive Database, but Life Issues Remain

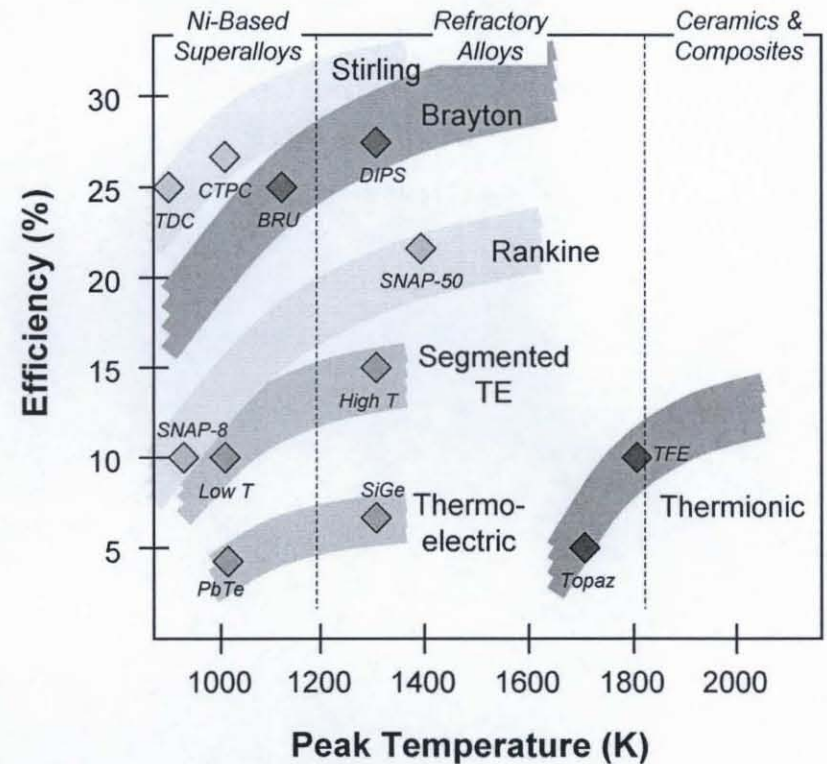



Closed Brayton Cycle

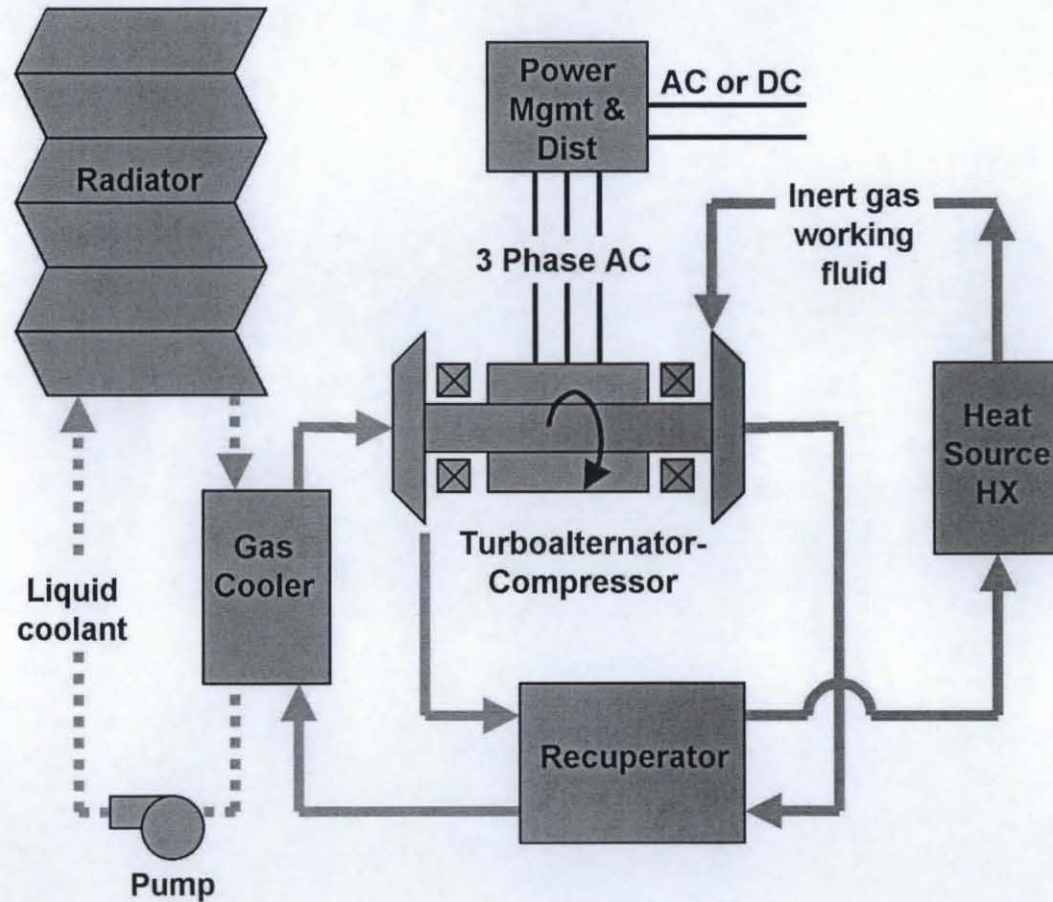



CBC Timeline

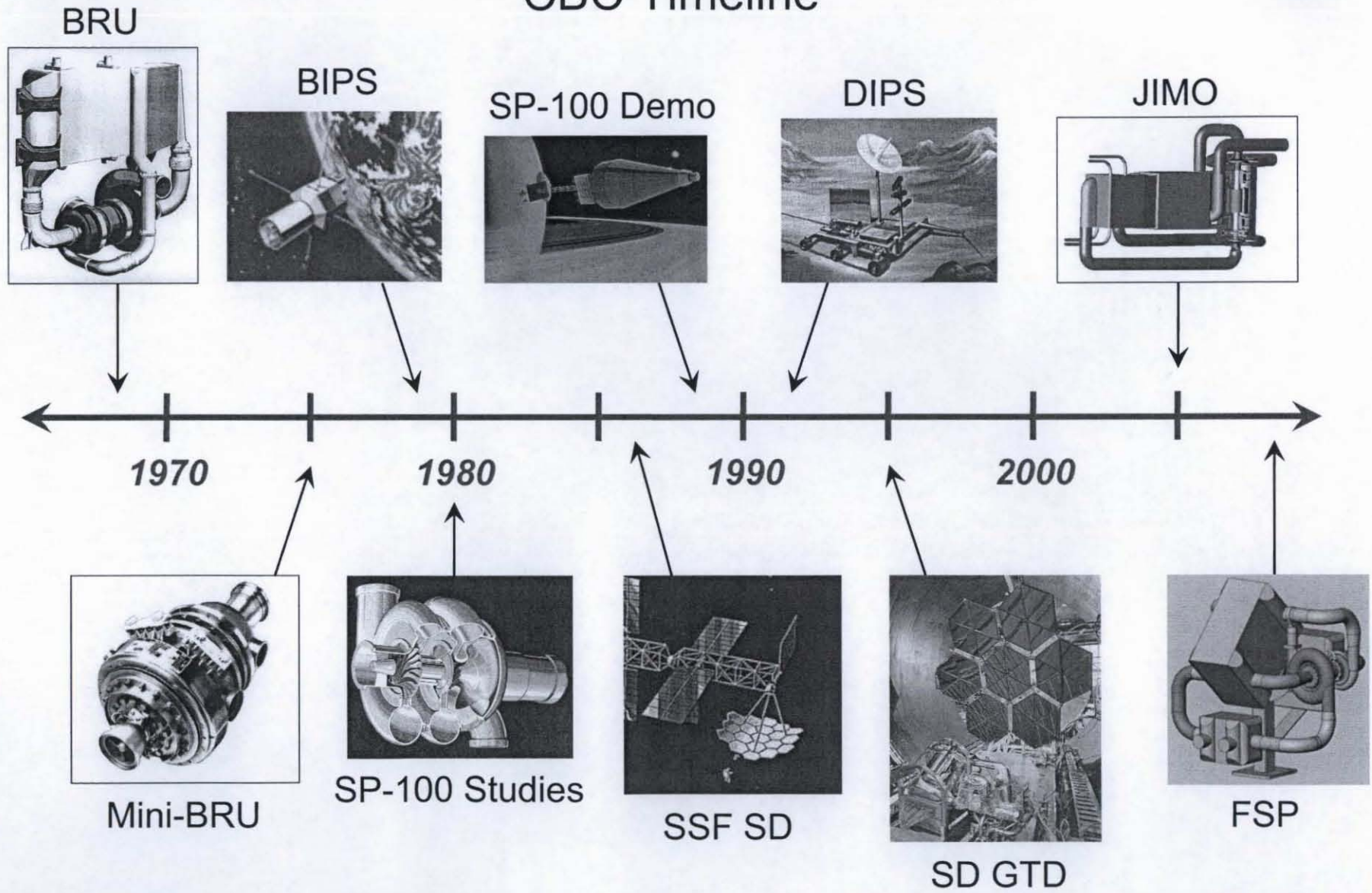



Brayton Rotating Unit

- First-ever Closed Brayton Cycle (CBC) power conversion system for space (1968-76)
 - 4 BRUs Fabricated by AiResearch and Tested at Lewis Research Center
 - Included Brayton Heat Exchanger Unit (BHXU) combined Recuperator and Cooler
- BRU Program Successfully Demonstrated:
 - Manufacturing & Assembly
 - Jacking Gas Startup
 - High Conversion Efficiency (>25%)
 - Material Compatibility
 - Tilt-Pad Bearings
 - Extended Life: 38000 Hrs Operation on One Unit Without Degradation, Approx. 50000 Hrs Total on Four Units
- Performance Parameters:
 - Alternator Output 2.25 to 15 kW_e
 - Turbine Inlet Temp 1144 K (1600 F)
 - Compressor Inlet Temp 300 K (80 F)
 - Compressor Exit Pressure 310 kPa (45 psia)
 - 36000 RPM, 1200 Hz, 208 V
 - 65 kg BRU, 200 kg BHXU

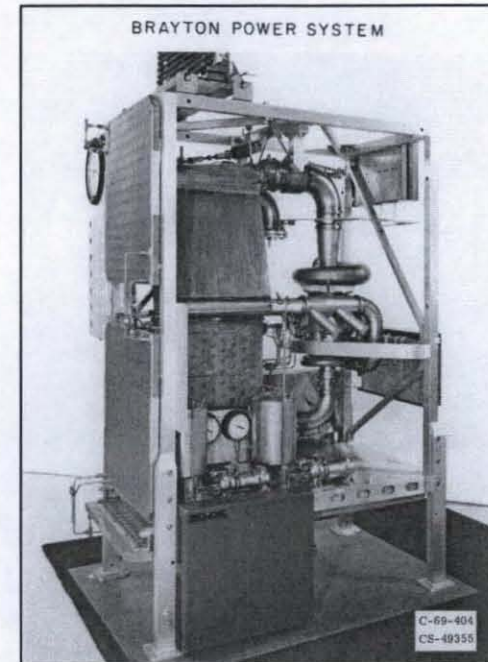

BRU Life Test



Turboalternator



BHXU



Mini-BRU

- Mini-BRU and Recuperator developed for use with Modular Isotope Heat Source (1974-78)
 - Built by AiResearch, Tested by Lewis
 - Major Differences from BRU: Lower Power, Foil Bearings, Internal Stator Cooling
 - Interchangeable Superalloy and Refractory Turbine Plenums Fabricated
- Led to 1.3 kW Brayton Isotope Power System (BIPS) development (DOE)
 - No Flight, but 1000 Hr Workhorse Loop Test
- Mini-BRU Successfully Demonstrated:
 - High Efficiency (>25%) at Lower Power
 - Foil Bearings
 - Alternator Motoring Startup
 - Leak-Free Recuperator Designs
- Performance Parameters:
 - Alternator Output 650 to 2100 watts
 - Turbine Inlet Temp 1144 K (1600 F)
 - Compressor Inlet Temp 300 K (80 F)
 - Compressor Exit Pressure 730 kPa (106 psia)
 - 52000 RPM, 1733 Hz, 67 V
 - 17 kg mini-BRU, 59 kg Recuperator

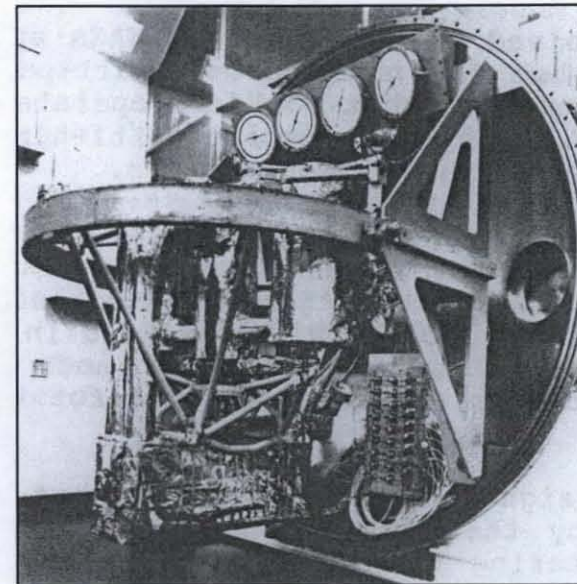

**BIPS
Workhorse
Loop**

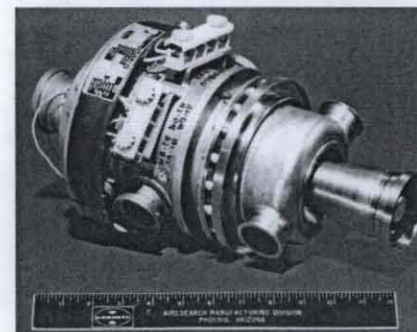

Turboalternator

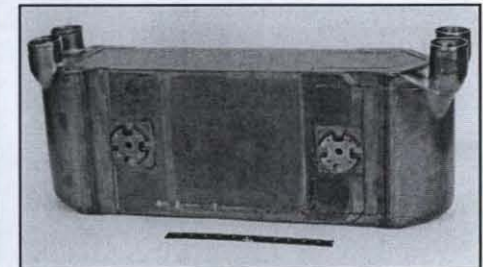

**Mini-BRU
Recuperator**



Solar Dynamic Brayton - Space Station Freedom

- 25 kW Solar Dynamic Power Module for Space Station Freedom (1986-91)
 - Part of Hybrid PV/SD Power System
 - Reduced Life Cycle Costs Compared to Photovoltaic/Battery System
 - 15 year On-Orbit life
 - Man-Rated System
- Phase C/D Design Completed
 - Higher Risk Components Built & Tested (e.g. Concentrator, Heat Receiver)
 - Power Conversion Unit Considered Low Risk due to BRU Heritage
- Performance Parameters
 - Alternator Output 36 kWe
 - Cycle Efficiency 27%
 - Turbine Inlet Temp 1034 K (1400 F)
 - Compressor Inlet Temp 338 K (148 F)
 - Compressor Exit Pressure 560 kPa (81 psia)
 - 32000 RPM, 120V
 - 104 kg Turboalternator-Compressor, 162 kg Recuperator, 85 kg Gas Cooler

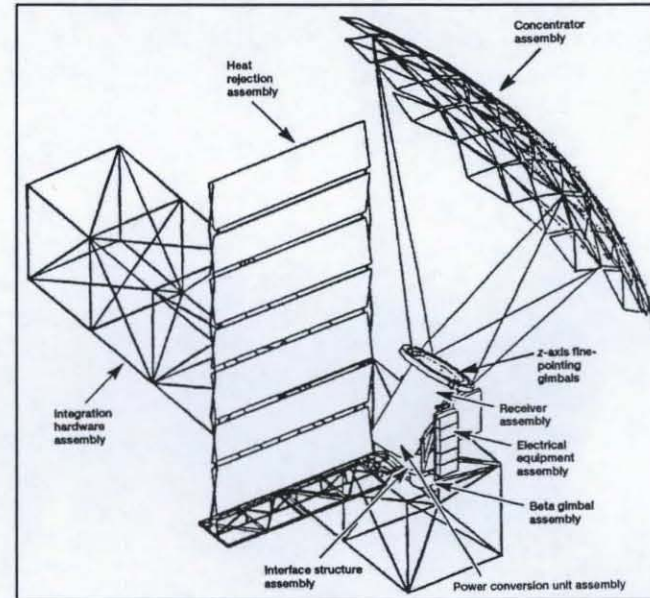

SD Flight Configuration

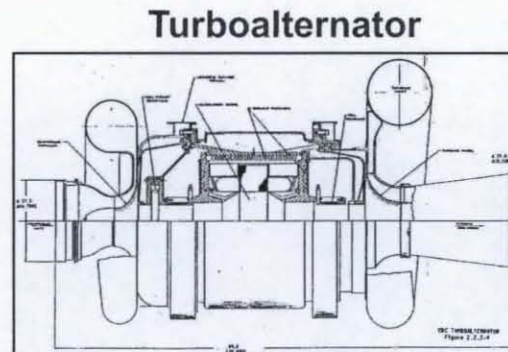

Turboalternator

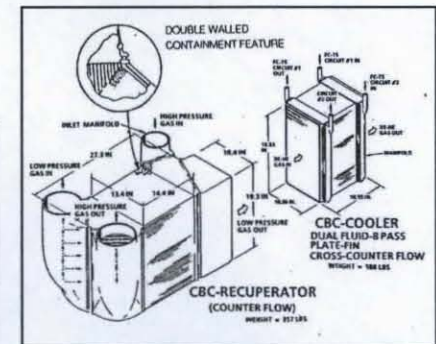

Recuperator/ Cooler



Solar Dynamic Ground Test Demonstration

- 2 kW Solar Dynamic Ground Test Demonstration (1994-98)
 - Congressional Ear-Mark Following Cancellation of SD Option for SSF
 - Full End-to-End System Test in Solar-Thermal-Vacuum (TRL6)
 - Government/Industry Team: NASA Lewis, Allied Signal, Harris, Loral-Vought, Rocketdyne
- Extensive Test Program
 - 33 Separate Tests, 372 LEO Orbit Cycles
 - 800 Hours of Operational Experience
 - No Performance Degradation
- Led to Joint US/Russian 2 kW Mir SD Flight Demo (1996-98)
 - Shuttle Delivery Mission Re-directed to Mir Re-supply
- Multiple Brayton Unit Configurations
 - Mini-BRU with 120V Rice Alternator
 - SD Mir Development Unit with 28V Permanent Magnet (PM) Alternator
 - SD Mir Unit with Rewound 120V PM Alternator

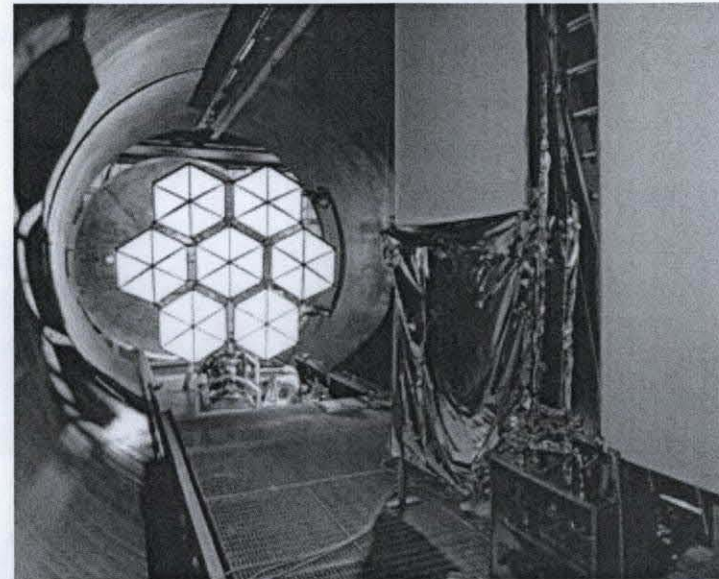

View from
Solar Sim.
Window Port

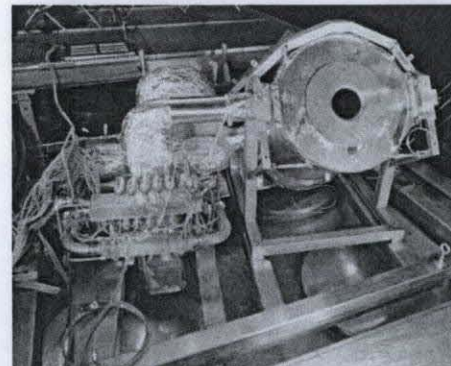

Heat Receiver &
Power Conversion Unit

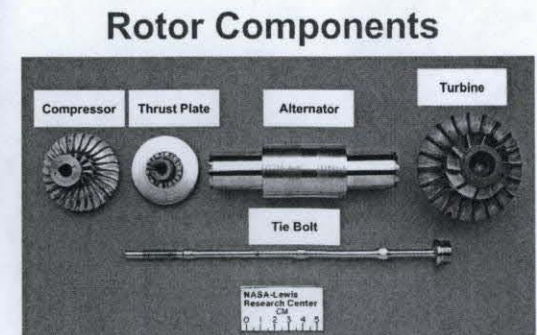

Rotor Components



Brayton Concepts & Studies

- 20 kW Brayton for Near-Term SP-100 Reactor Flight Demonstration Mission
- 6 kW Dynamic Isotope Power System (DIPS) for Air Force Boost Satellite Tracking System (BSTS)
- 500 watt to 2.5 kW DIPS for Space Exploration Initiative (SEI)
 - Science Rovers
 - Surface Utility Power
- 100 to 550 kW SP-100 Brayton for Lunar and Mars Surface Missions
- Bi-Modal Nuclear Thermal Rocket with 25 to 50 kW Brayton

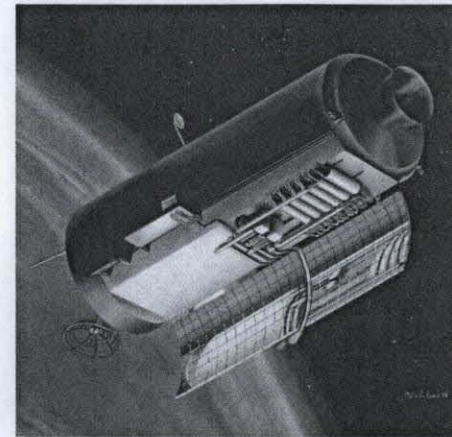

6 kW DIPS

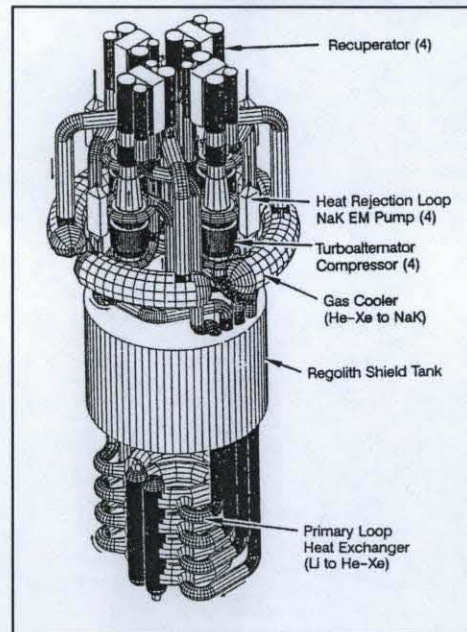

Bi-Modal NTR

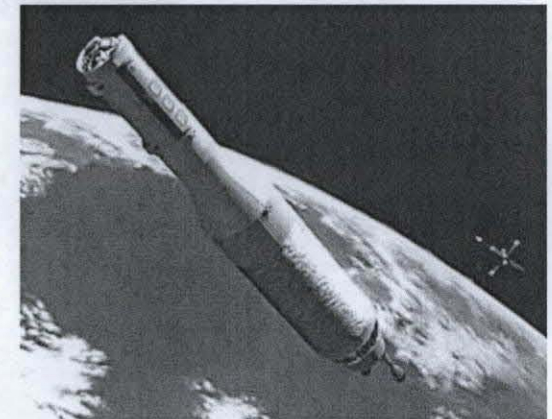

550 kW SP-100 Brayton For Lunar Surface



Jupiter Icy Moons Orbiter (JIMO) Brayton

**Liquid-Metal Reactor with
1+1 Brayton (100 kWe)**



**Liquid-Metal Reactor with
2+2 Brayton (135 kWe)**

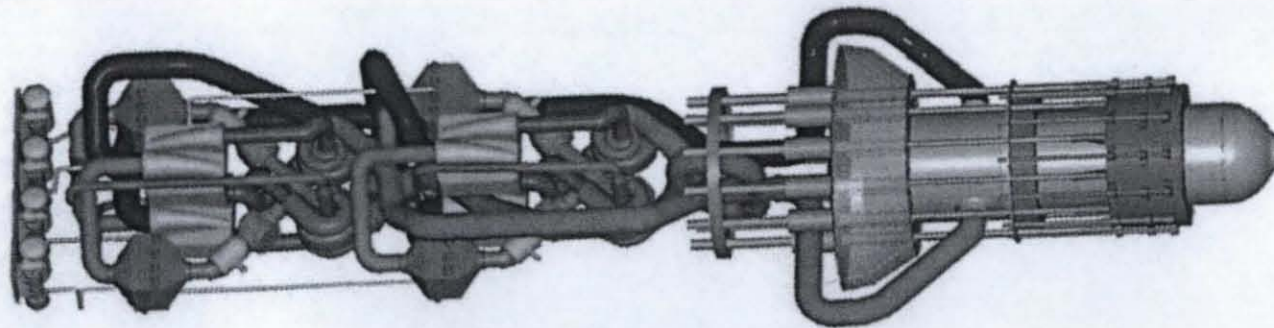
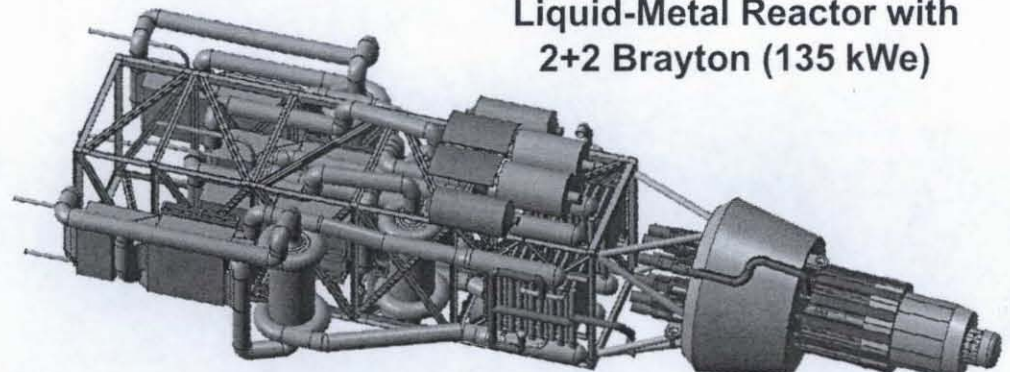

**Gas-Cooled Reactor with
2+2 Brayton (200 kWe)**



2 kW Brayton Testbed

- 2 kW “Space-Like” Closed Brayton Unit for JIMO Risk Reduction
 - Brayton Converter from SD GTD; Formerly “Mini-BRU”
 - Electrical Shell & Tube Helium-Xenon Gas Heater
 - Commercial Ethylene Glycol Chiller
 - 120 Vdc Electrical Controller & Parasitic Load Radiator
 - Alternative 1100 Vdc Controller for Electric Propulsion Testing
- Recent Testing Completed:
 - Performance Mapping (Jun ‘02)
 - Ion Thruster Demo (Dec ‘03)
 - Mech. Dynamics Test (Nov ‘04)
 - Thermal Transients Test (Sep ‘05)

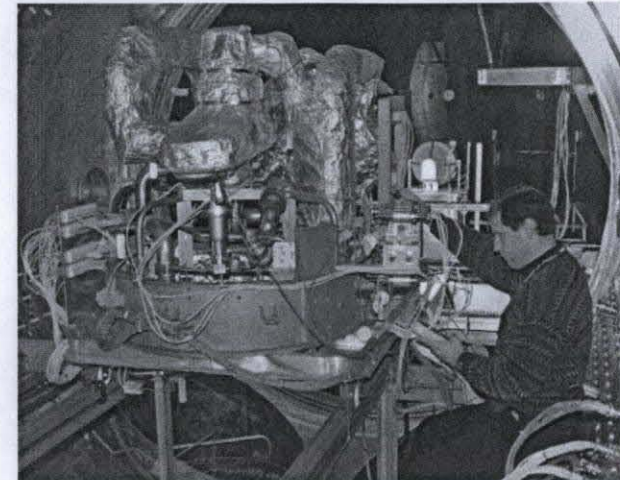

Evaluate Transient Thermal Response & Validate Codes

Demonstrate HV Distribution & EP Thruster Integration

Measure Mech. Vibrations & Validate Codes

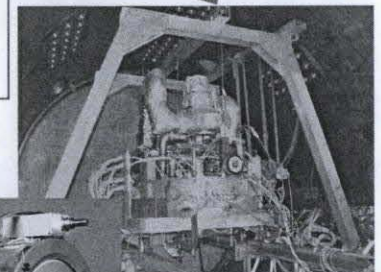



Dual Capstone Brayton Loop

- System Designed and Built by Barber Nichols, Arvada CO
 - Uses Two Commercial Capstone Micro-Turbine Generators
 - Modified for Closed-Loop Operation
 - Common Nitrogen Gas Loop; No Isolation Valves
 - Shared (180 kW) Electrical Resistance Heater; Water Cooling
- First-of-a-Kind Test System
 - Representative of Direct-Gas Reactor with redundant Brayton units
 - Permits evaluation of operational interactions
- GRC Testing Completed May-08
 - Operated up to 22 kW Total Power, 950K Turbine Inlet, 90000 rpm
 - Equal & Unequal Shaft Speeds
 - Single and Dual Unit Operation
 - Staggered & Simultaneous Startup
 - Analytical Model Validation

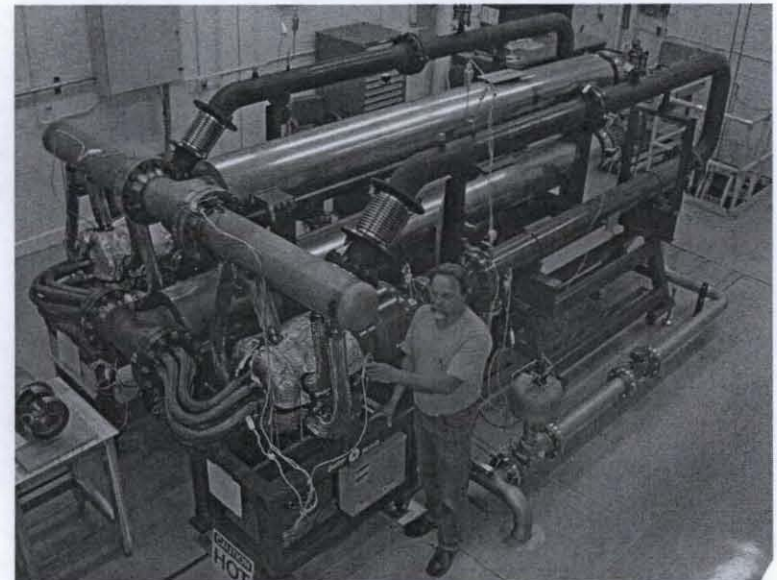



Dual Capstone - Equal Shaft Speeds

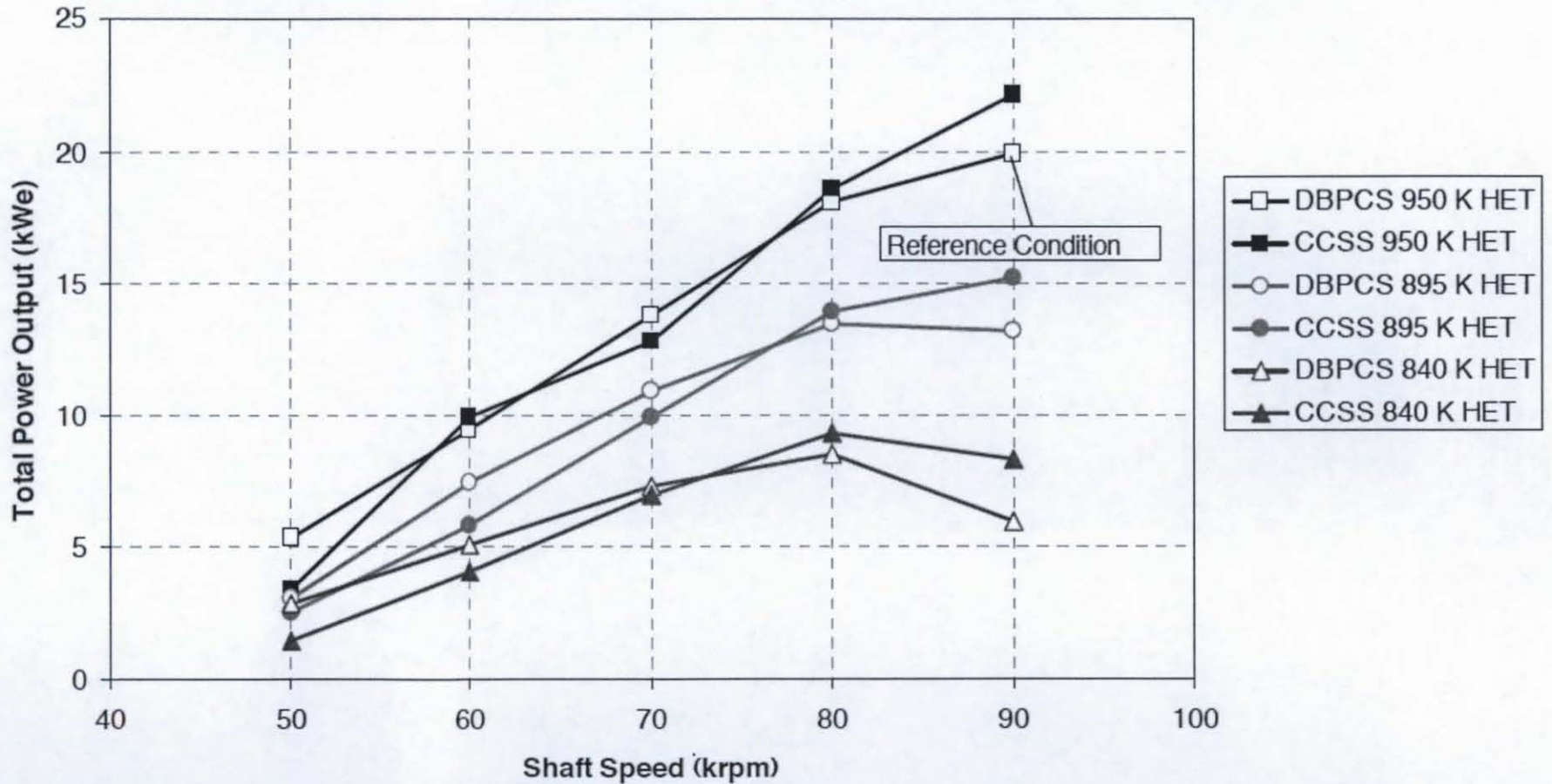

DBPCS=Dual Brayton Power Conversion System; CCSS=Closed Cycle System Simulation



Dual Capstone - Unequal Shaft Speeds

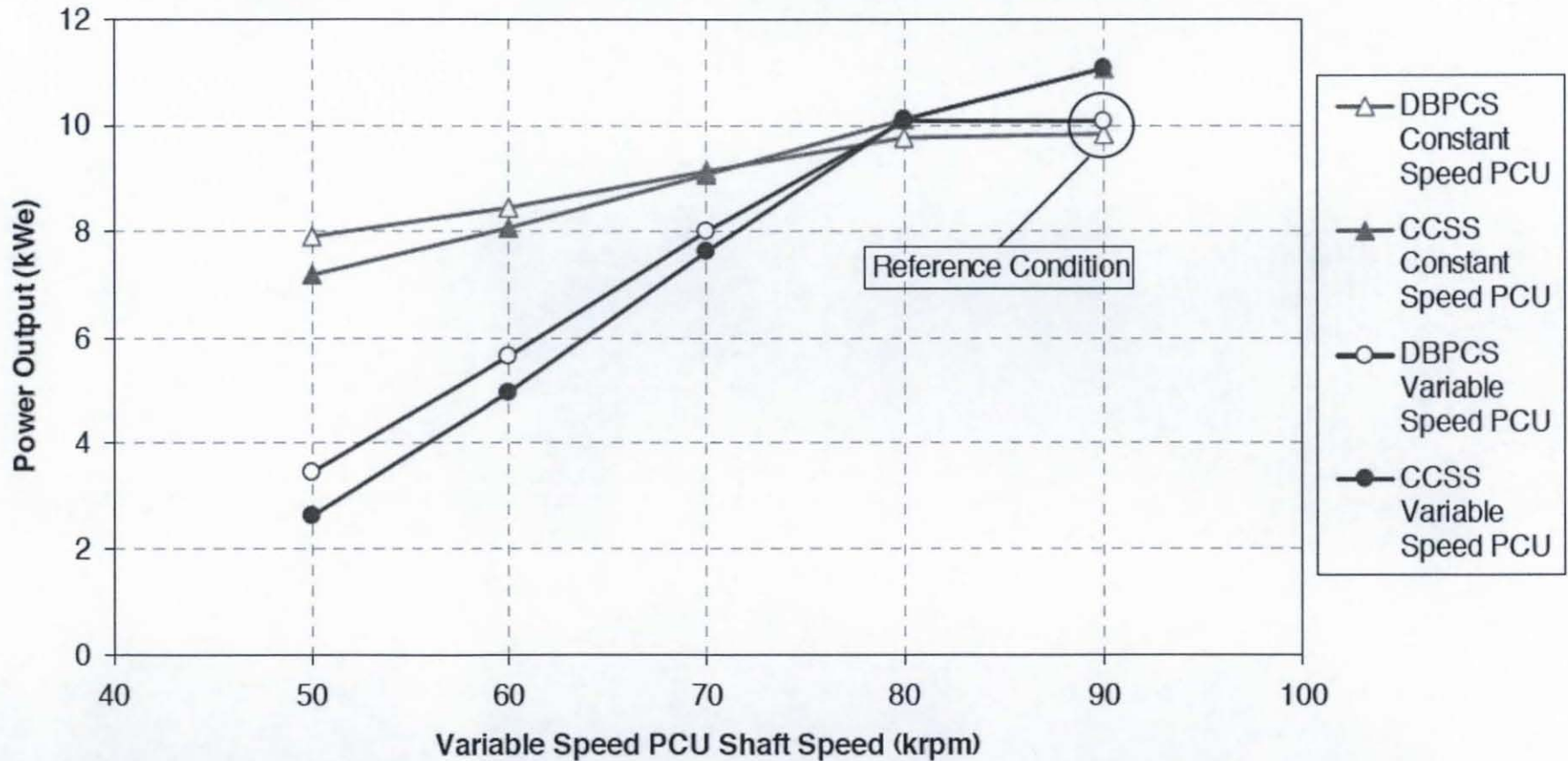

DBPCS=Dual Brayton Power Conversion System; CCSS=Closed Cycle System Simulation



Fission Surface Power Concept

- Modular 40 kWe System with 8-Year Design Life suitable for (Global) Lunar and Mars Surface Applications
- Emplaced Configuration with Regolith Shielding Augmentation Permits Near-Outpost Siting (<5 rem/yr at 100 m Separation)
- Low Temperature, Low Development Risk, Liquid-Metal (NaK) Cooled Reactor with UO_2 Fuel and Stainless Steel Construction

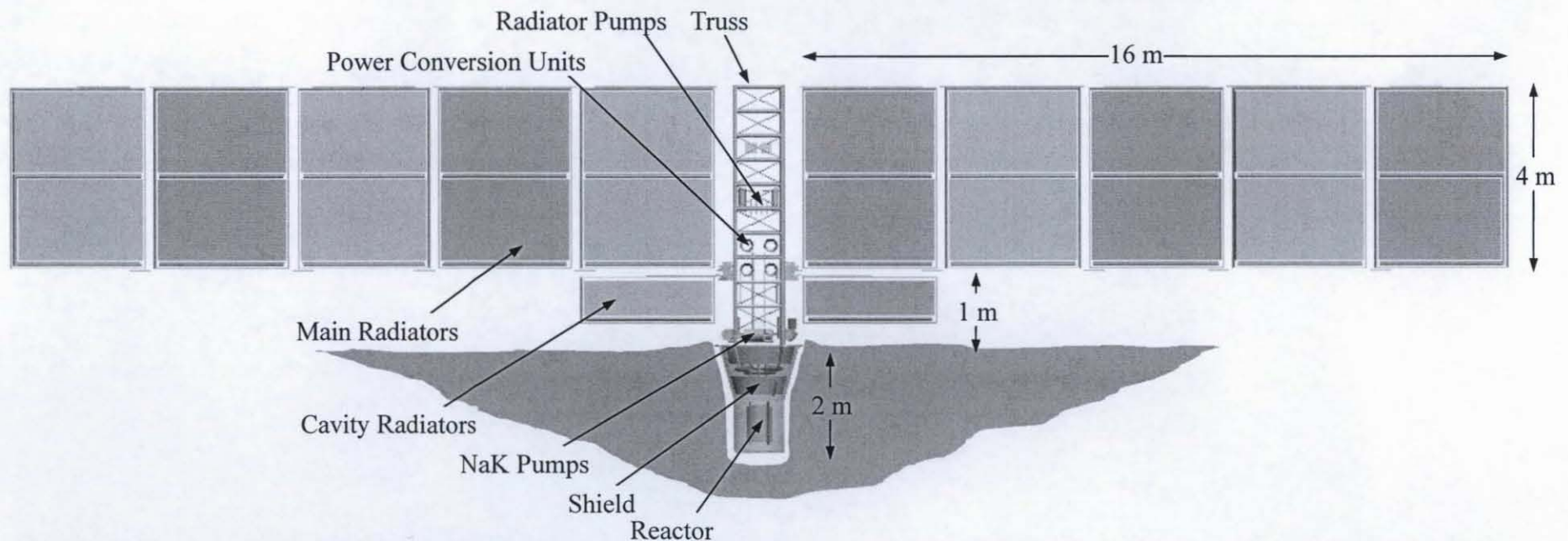



Direct Drive Gas Brayton

- 2 kW Closed Brayton Power Conversion Unit from Solar Dynamic Ground Test
 - Modified for Prometheus-JIMO Power Conversion tests
 - Flight-like Brayton: 900K Turbine Inlet, 300K Compressor Inlet, 52000 rpm, He-Xe Working Fluid
- Direct Drive Gas (DDG) Reactor Simulator from MSFC
 - Designed & tested during JIMO with non-representative heat sink
 - Pin heater elements in core-like bundle
 - Stainless steel clad & vessel
- Completed integration & initial checkout testing at GRC Dec-08
- Full performance characterization and controls test completed in Feb-09
 - Temperature Control
 - Simulated Reactor Feedback

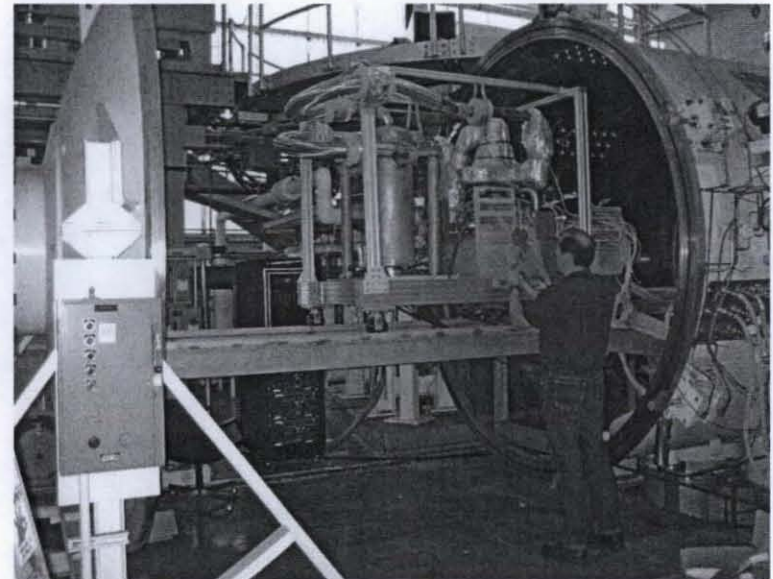



DDG Brayton Reactivity Simulations

Response to Brayton Speed Decrease

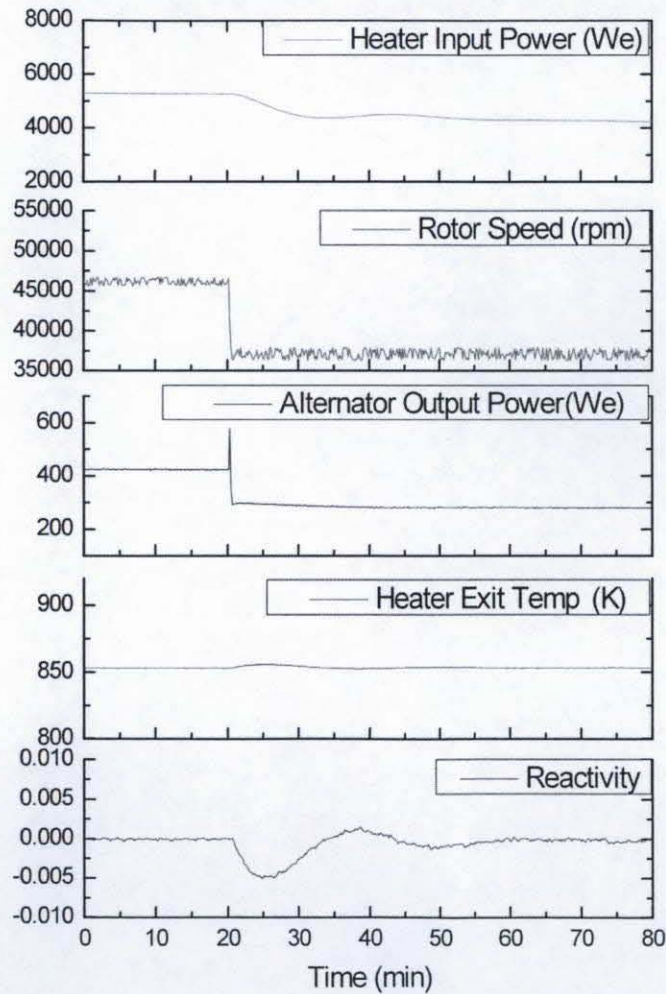

Response to Neg. Reactivity Insertion

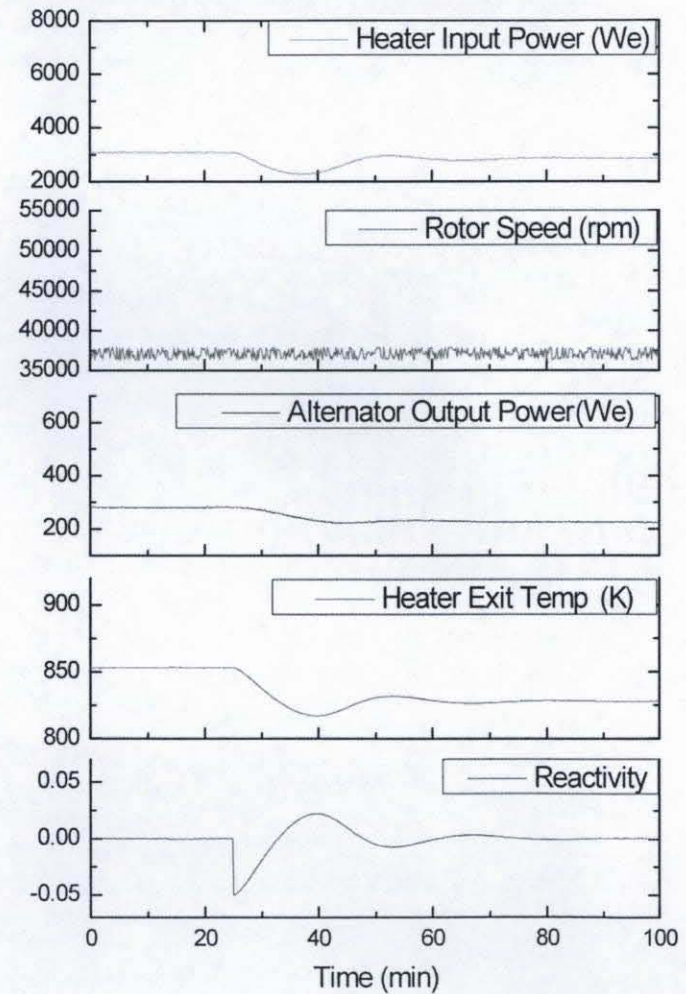



Technology Demonstration Unit - Objectives

- Reduce FSP Development Risk
- Verify System-Level Performance in Realistic Environment
- Characterize Component Performance in a System Context
- Obtain Operational Data under Steady-State and Transient Conditions
- Develop System Control Methods
- Benchmark Analytical Codes
- Gain System Operations Experience for the NASA/DOE Team
- Expand Industrial Infrastructure for Component Design and Fabrication
- Obtain As-Built Mass and Cost Data
- Provide Tangible and Measurable Technology Milestone

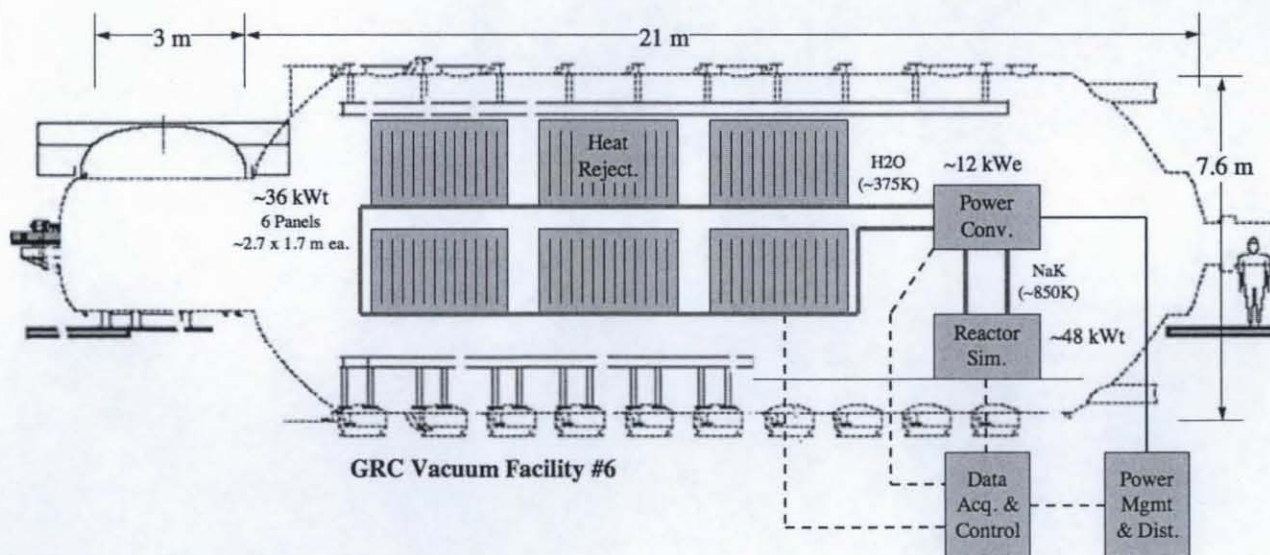

**Notional TDU Test
Layout in GRC
Vacuum Facility #6**



Full-scale Power Conversion Unit Contracts

- Two Phase I Design & Analysis contracts awarded May-08
 - Sunpower (Stirling) and Barber Nichols (Brayton)
 - Approach provides parallel and diverse design path for Full-scale (12 kWe) PCU for FSP Technology Demonstration Unit (TDU)
 - Both Final Design Reviews completed in Apr-09 at GRC
 - Only one contractor will be selected for Phase II Fabrication & Test (Summer 2009)

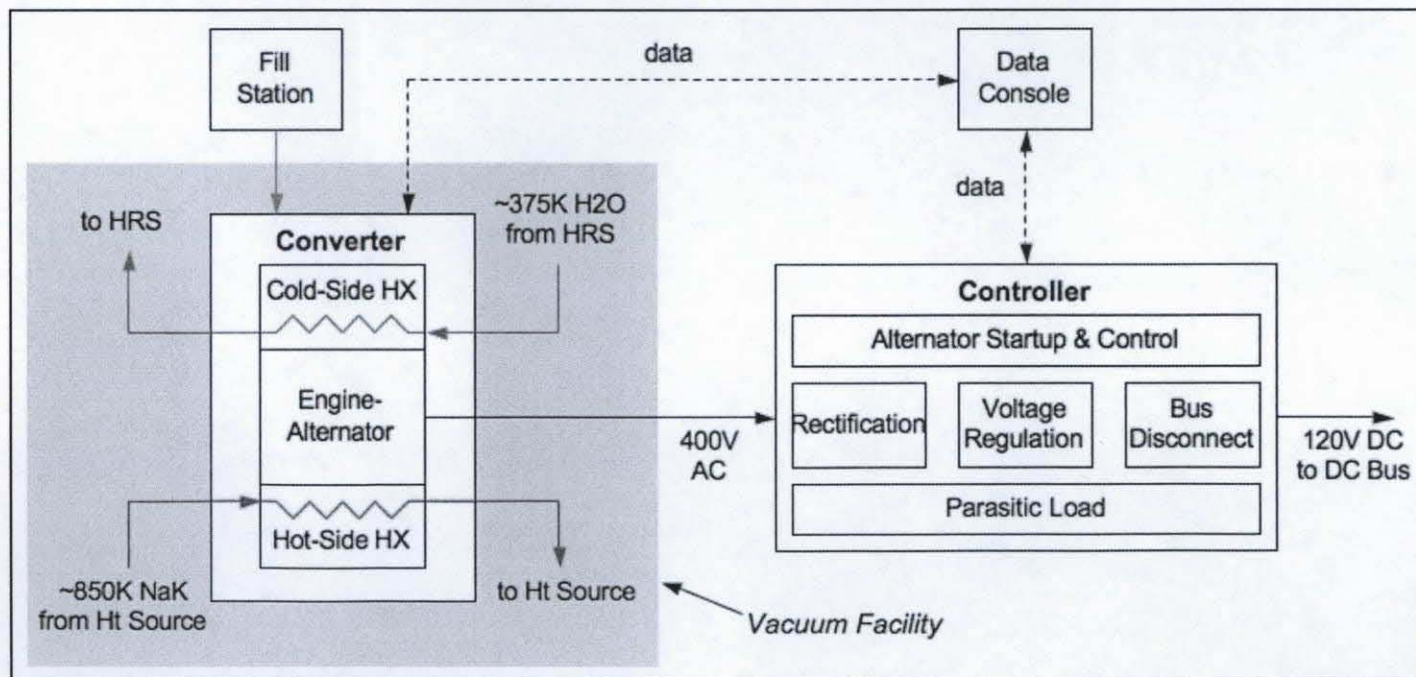



Full-scale 12 kW PCU Designs

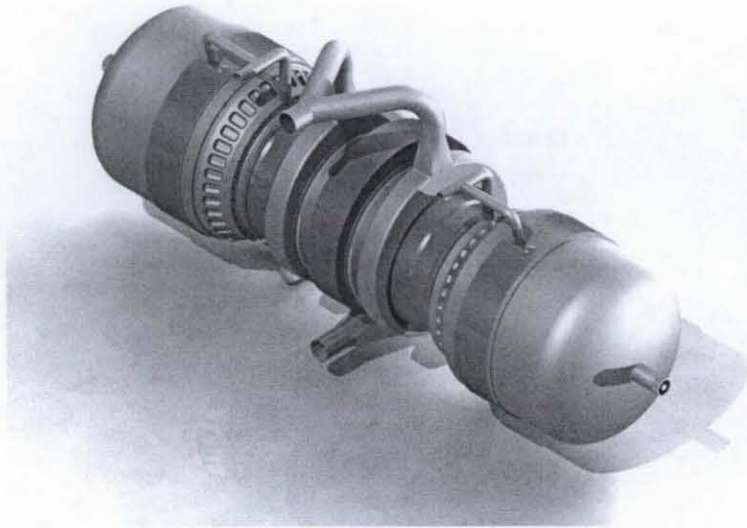

Courtesy of Sunpower

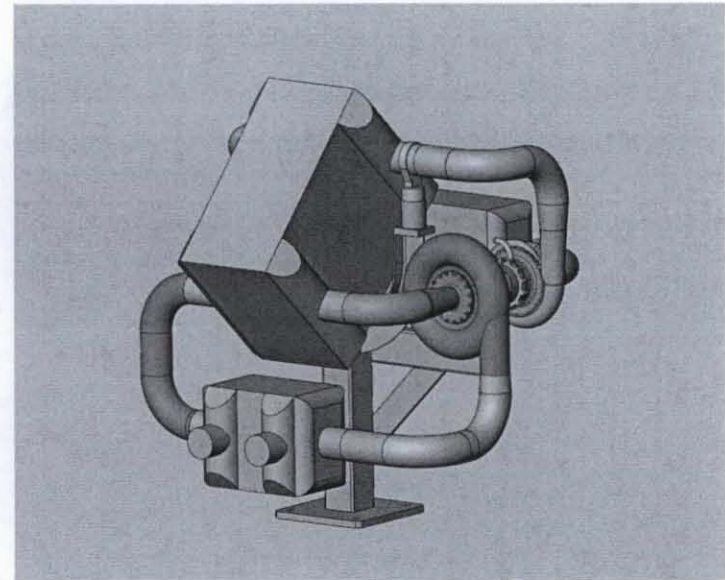

Courtesy of Barber Nichols



Summary

- Long History of Closed Brayton Technology Development within NASA & DOE
 - Brayton Rotating Units
 - Solar Dynamic Brayton
 - SP-100 Brayton
 - Dynamic Isotope Power System
 - Jupiter Icy Moons Orbiter
 - Fission Surface Power
- Primary Benefits of Brayton include:
 - High Efficiency
 - Scalable to High Power
 - Potential for Long Life and High Reliability
 - Readily Adaptable to Solar and Nuclear Heat Sources
 - Simple and Efficient Electrical Integration