

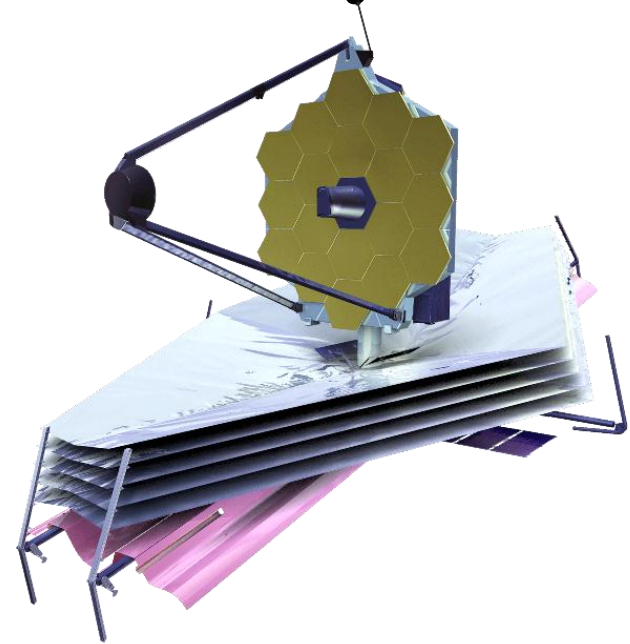

50+ years of NASA Mirror Technology Development:

from Hubble to JWST and Beyond



H. Philip Stahl, Ph.D.
NASA

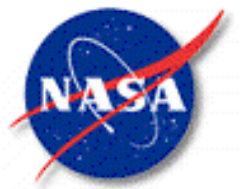

- WHERE IS THE U.S. GOING IN SPACE ?
- WHAT PROSPECTIVE NATIONAL GOALS REQUIRE NEW SPACE OPTICS ?
- SPACE ASTRONOMY
 - RESOLUTION
 - ULTRAVIOLET SPECTROSCOPY
 - INFRARED SPECTROSCOPY
- PLANETARY PROBES
 - LASER COMMUNICATION



Presidential Vision

“... both optical and radio astronomy ... new fields of interest have been uncovered – notably in the high energy x-ray and gamma-ray regions. Astronomy is advancing rapidly at present, partly with the aid of observations from space, and a deeper understanding of the nature and structure of the Universe is emerging ... Astronomy has a far greater potential for advancement by the space program than any other branch of physics”.

SPACE ASTRONOMY NEEDS

● LARGE - APERTURE DIFFRACTION - LIMITED OPTICS

2 METER
3 METER
10 METER

● FINE POINTING SYSTEMS ($< \frac{1}{100}$ SEC.)

ALL WAVELENGTH TRANSFER LENS
PRECISE TORQUER GIMBALS
FREE FLOAT TELESCOPES

● SPACE MAINTAINABILITY

ALIGNMENT AND TUNE - UP
MODULAR SERVICING
SCIENTIFIC EXPERIMENTS FLEXIBILITY

Perkin-Elmer 1967



Presidential Vision

“... both optical and radio astronomy ... new fields of interest have been uncovered – notably in the high energy x-ray and gamma-ray regions. Astronomy is advancing rapidly at present, partly with the aid of observations from space, and a deeper understanding of the nature and structure of the Universe is emerging ... Astronomy has a far greater potential for advancement by the space program than any other branch of physics”.

Space Task Group report to the President, September 1969

“A Long-Range Program in Space Astronomy”, position paper of the Astronomy Missions Board, Doyle, Robert O., Ed., Scientific and Technical Information Division Office of Technology Utilization, NASA, July 1969.

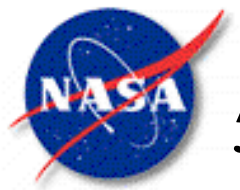

55 years ago in 1957 Space Astronomy Changed

On Oct 4, 1957 the world changed – Sputnik was placed in orbit around the Earth – and the Space Race was begun.

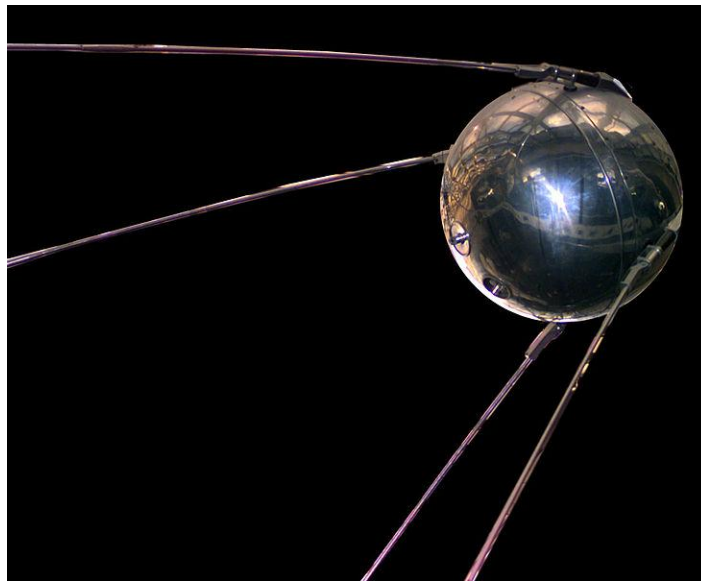

NASA formally opened for business on Oct. 1, 1958.



State of Art before Sputnik

There are two important dates for American Space Astronomy before Sputnik:

10 Oct 1946, the first Ultraviolet Spectrum (to 210 nm) of the sun was obtained via a small film camera spectrograph mounted on a German V-2 Rocket launch by Von Braun's group at White Sands, NM.

25 Sept 1957, the first launch of Stratoscope I.



US test launch of a Bumper V-2

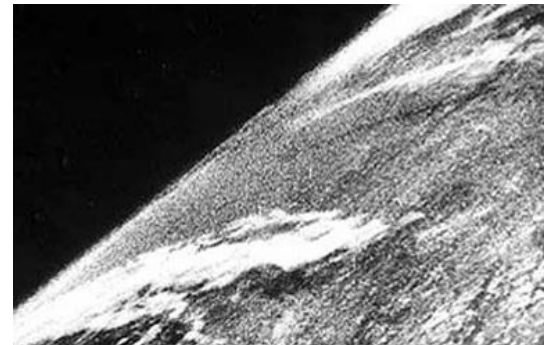

First Image of Earth from Space

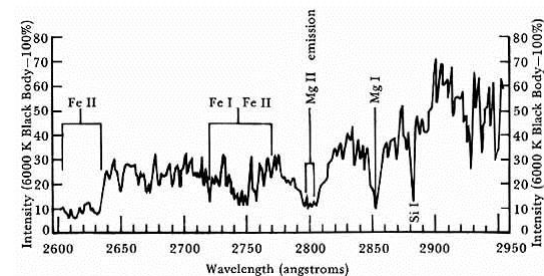

First UV Solar Spectra from Space

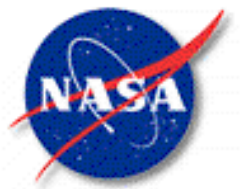

Stratoscope I & II – 1957 to 1971

Stratoscope I (initial 25 Sept 1957)

Conceived by Martin Schwarzschild

Build by Perkin-Elmer

30 cm (12 inch) primary mirror

Film recording

Stratoscope II

Conceived by Martin Schwarzschild

Build by Perkin-Elmer

90 cm (36 inch) primary mirror

Payload 3,800 kg

25 km altitude

Film & Electronic



MSFC Launch September 9, 1971



Space Astronomy

But,

Rocket Missions last for only a few minutes

Balloon Missions operate in the presence of Gravity and have a relatively 'soft' ride.

And neither are truly space.



The Berkner Telegram

On July 4, 1958, Dr. Lloyd Berkner, Chair of the Space Science Board of the National Academy of Sciences, sent telegrams requesting suggestions for scientific experiments that may be performed by a satellite with a 50 kg capacity & fly in 2 years.

Proposals were due in 1 week. He got 200 responses.

This telegram and its responses lead to the OAO program.

- Kick-off meeting was in 1959

- Ames defined Requirements

- GSFC was lead center

- Grumman was Prime.

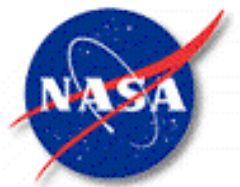

Orbiting Astronomical Observatory (OAO)

From 1966 to 1972 NASA launched 4 OAO satellites

All had UV Science Experiments

OAO-I April 1966: Failed due to corona arching.

OAO-II Dec 1968 (on Atlas Centaur) to Jan 1973

OAO-B Nov 1970: Failed, Atlas Centaur didn't achieve orbit

OAO-C Aug 1972 to Feb 1981

OAO-II, B, and C Experiments and Principal Investigators

Spacecraft	Experiment	Principal Investigators
OAO-II	University of Wisconsin Experiment	Dr. A.D. Code, Dr. T.E. Houck Univ. of Wis. Space Astronomy Laboratory
	Smithsonian Astrophysical Observatory Experiment	Dr. F. Whipple, Dr. R.J. Davies Smithsonian Astrophysical Observatory
OAO-B	GSFC Experiment	Dr. A. Boggess II - Goddard Space Flight Center
OAO-C	Princeton University Experiment (Princeton Experiment Package)	Dr. Lyman Spitzer, Dr. John B. Rogerson, Jr. ; Princeton Univ.
	University College, London England	Prof. R.F.L. Boyd - University College, London

27
FOR OFFICIAL USE ONLY

107-0004

EXECUTION PHASE
PROJECT PLAN
FOR
ORBITING ASTRONOMICAL OBSERVATORIES
(OAO-II, -B AND -C)
REVISION 4

107-4

HEADQUARTERS MANAGEMENT
APPROVAL COPY

NASA

GODDARD SPACE FLIGHT CENTER
GREENBELT, MARYLAND

FOR OFFICIAL USE ONLY

Jone



OA-C (Copernicus)

OA-C had two Science Experiments

Princeton Experiment Package was a
UV Spectrometer

81 cm Cassegrain telescope

Built by Perkin-Elmer for Princeton

Fine Guider achieved 0.1 arc-sec pointing

London Experiment X-Ray Package

3 small x-ray telescopes

5.5 cm² for 3 to 9 Angstroms

12 cm² for 6 to 18 Angstroms

23 cm² for > 44 Angstroms

Deep parabolic grazing incidence mirrors

'first' piggy-back experiment

'first' x-ray telescopes in space?

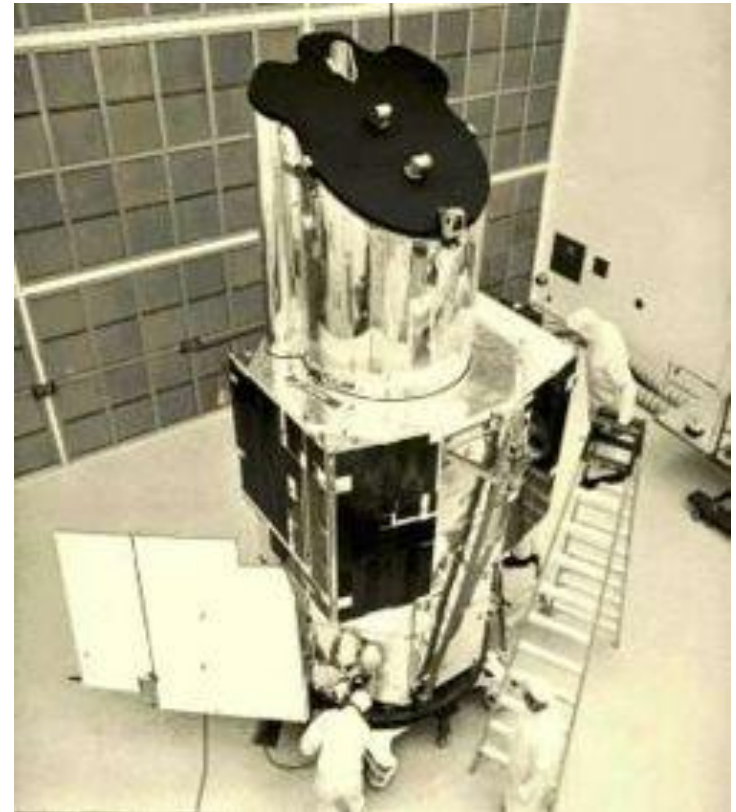

NASA SPACE OPTICS TECHNOLOGY PLAN

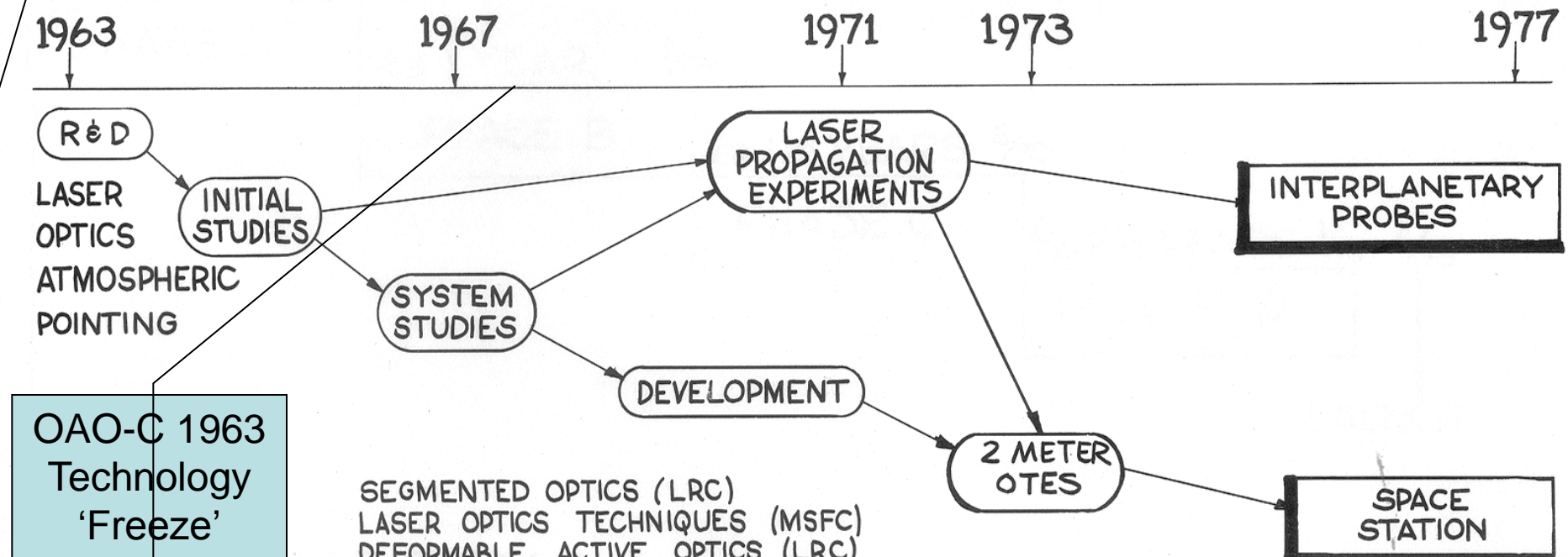

"Active Optical Systems for Space Stations", Hugh Robertson, PE, Jan 1968.
 "Advanced Optical Figure Sensor Techniques", Robert Crane, PE, Jan 1968
 "Advanced Actuator Project", Hugh Robertson, PE, Jan 1968.
 "Thermal Vacuum Figure Measurement of Diffraction Limited Mirrors", J. Bartas, PE, Aug 1968
 "Silicon Mirror Development for Space Telescopes", David Markle, PE, Aug 1968
 "Fabry-Perot Filters for Solar and Stellar Astronomy", David Markle, PE, Aug 1968
 "Study of Telescope Maintenance and Updating in Orbit", ITEK, May 1968

8.2 Observatories Roadmap (OCT, 2011)

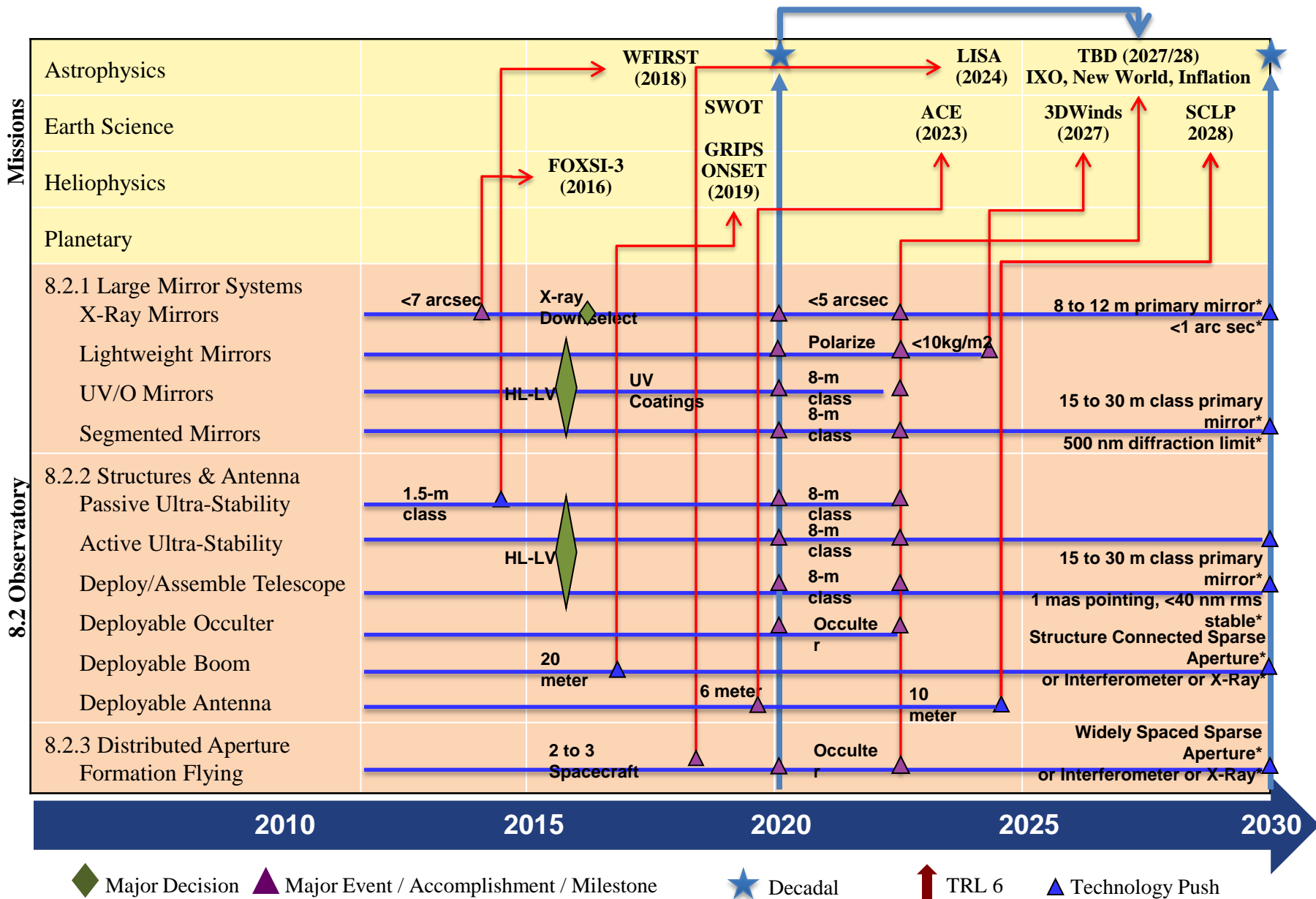

NASA SPACE OPTICS TECHNOLOGY PLAN

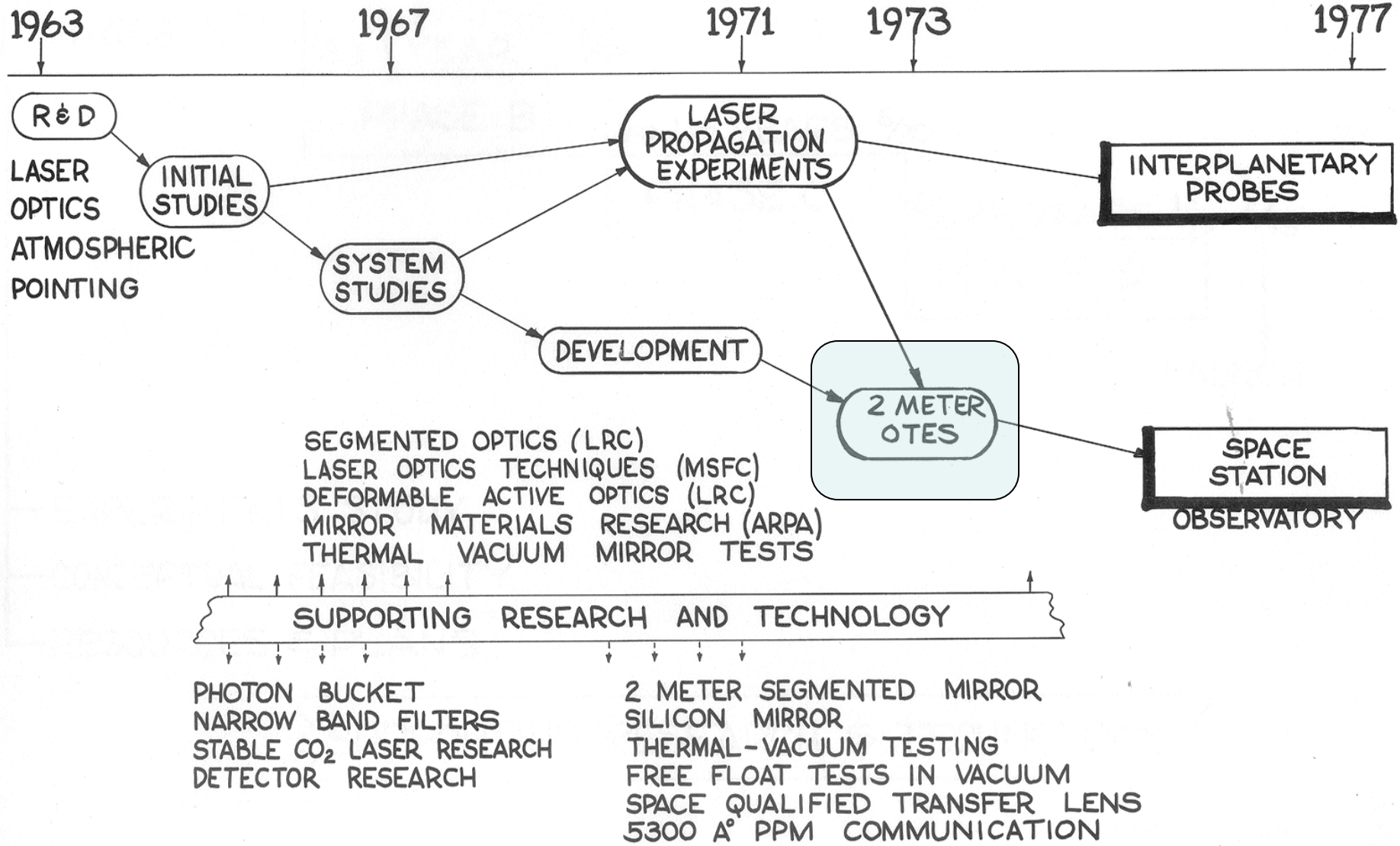

SYSTEMATIC SEARCH FOR
SPACE OPTICAL TECHNOLOGY EXPERIMENTS

CONCEPT FEASIBILITY AND PLANS FOR
OPTICAL TECHNOLOGY EXPERIMENT SYSTEM

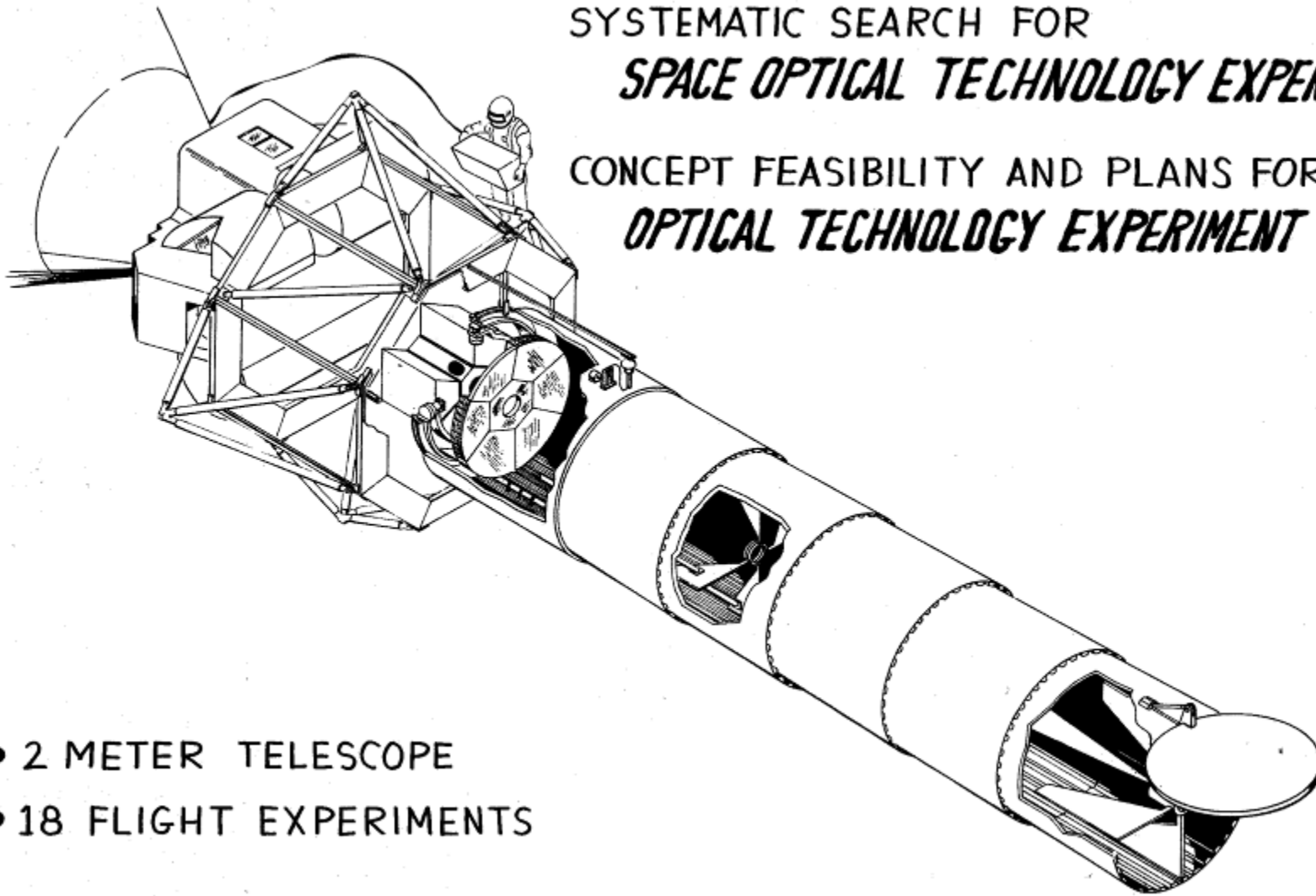

- 2 METER TELESCOPE
- 18 FLIGHT EXPERIMENTS

PERKIN-ELMER

Optical Technology Experiment System (OTES), PE, 1967
Large Telescope Experiment Program (LTEP), PE 1969

2-METER OTES JUSTIFICATION

PROVIDE NASA WITH DATA FOR NATIONAL SPACE OBSERVATORY

- ORBITAL ALTITUDE DECISION DATA
 - DAYLIGHT ASTRONOMY
 - POINTING DISTURBANCES
 - THERMAL BALANCE
- MANNED SPACE ASTRONOMY TECHNIQUES
 - ERECTION
 - ALIGNMENT
 - MODIFICATION
 - MAINTENANCE
- PRIMARY MIRROR EVALUATION
 - ACTIVE OPTICS
 - SEGMENTED TESTS
 - DEFORMABLE TESTS
 - THERMAL TESTS
 - MATERIALS
 - QUARTZ
 - SILICON
 - CERVIT
 - BERYLIUM
- POINTING DEVELOPMENT
 - TRANSFER LENS
 - FREE FLOAT
 - FLEXURE GIMBALS
 - CLUSTER — AUTONOMOUS MODES



“Large Telescope Experiment Program (LTEP)”, Perkin-Elmer, Aug 1969



Large Telescope Experiment Program (LTEP)

Funded by the NASA Apollo Application Office

NASA is seriously searching out meaningful goals for after the most successful Saturn-Apollo missions to the lunar surface.

The new science and technologies of space labs and solar observatories are in the immediate future.

Data ... are critical for settling major questions in cosmology:

is the Universe infinite or not.”

“Large Telescope Experiment Program (LTEP) Executive Summary”, Alan Wissinger,
April 1970



National Astronomical Space Observatory (NASO)

Initial Specifications:

- Operated at permanent space station
- Aperture of 3 to 5 meters
- Spectral Range from 80 nm to 1 micrometer
- Diffraction limit of at least 3 meters (0.006 arc-seconds) at 100 nm.
- Interchangeable experiment packages
- Life time of 10 years
- Field Coverage = 30 arc min
- Pointing Accuracy of 6 milli-arc second
- Thermal control - -80C +/- 5 C
- Mass (telescope only) = 5500 lb

“Large Telescope Experiment Program (LTEP) Executive Summary”, Alan Wissinger,
April 1970

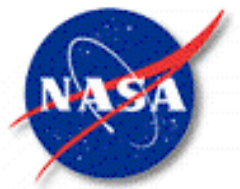

Initial Launch Configuration for Saturn IB

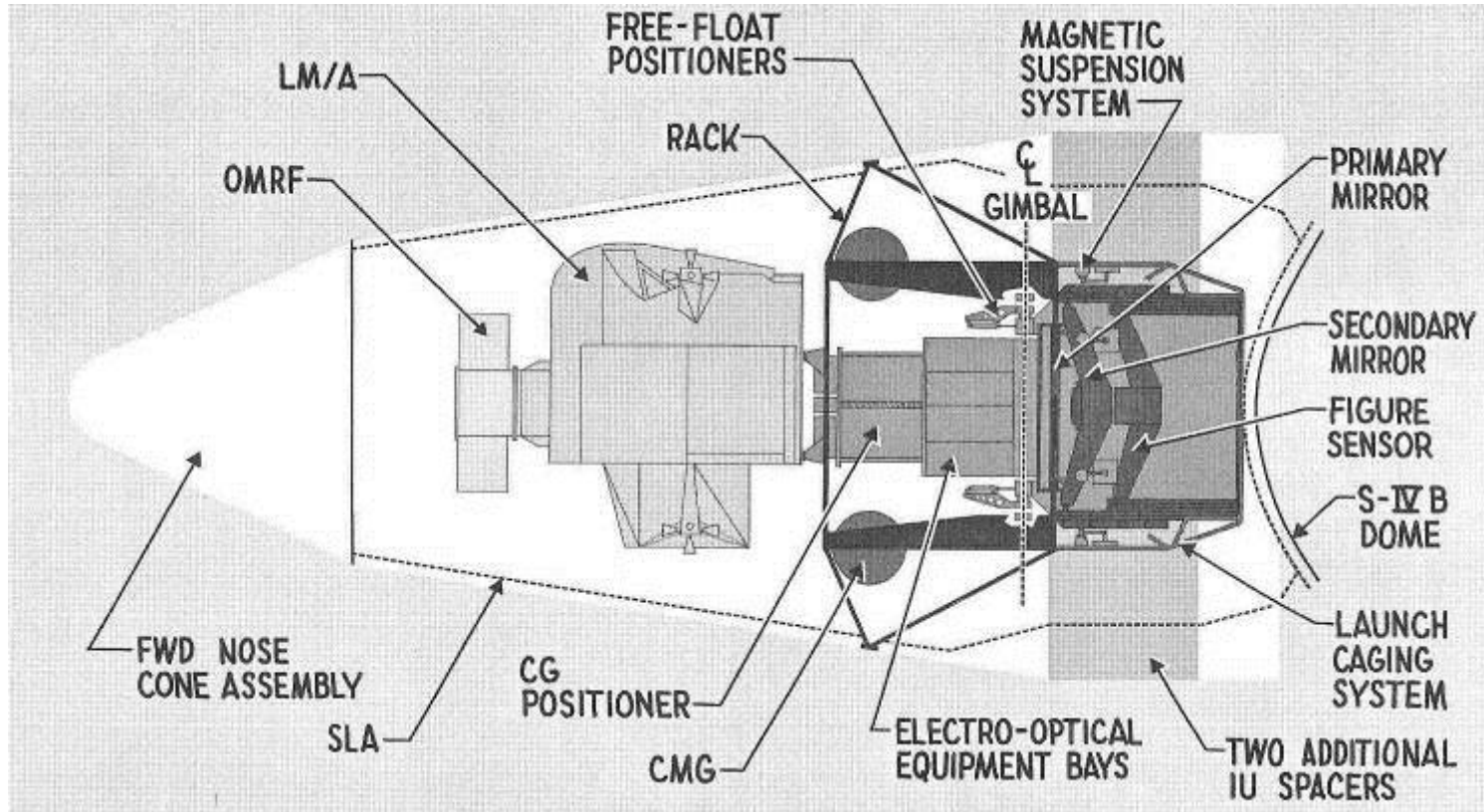

“Large Telescope Experiment Program (LTEP)”,
Lockheed Missiles and Space Company, Jan 1970



“Large Telescope Experiment Program (LTEP)”, Perkin-Elmer, Aug 1969

LTEP-2-METER CONCEPT: EXTENDED CONFIGURATION

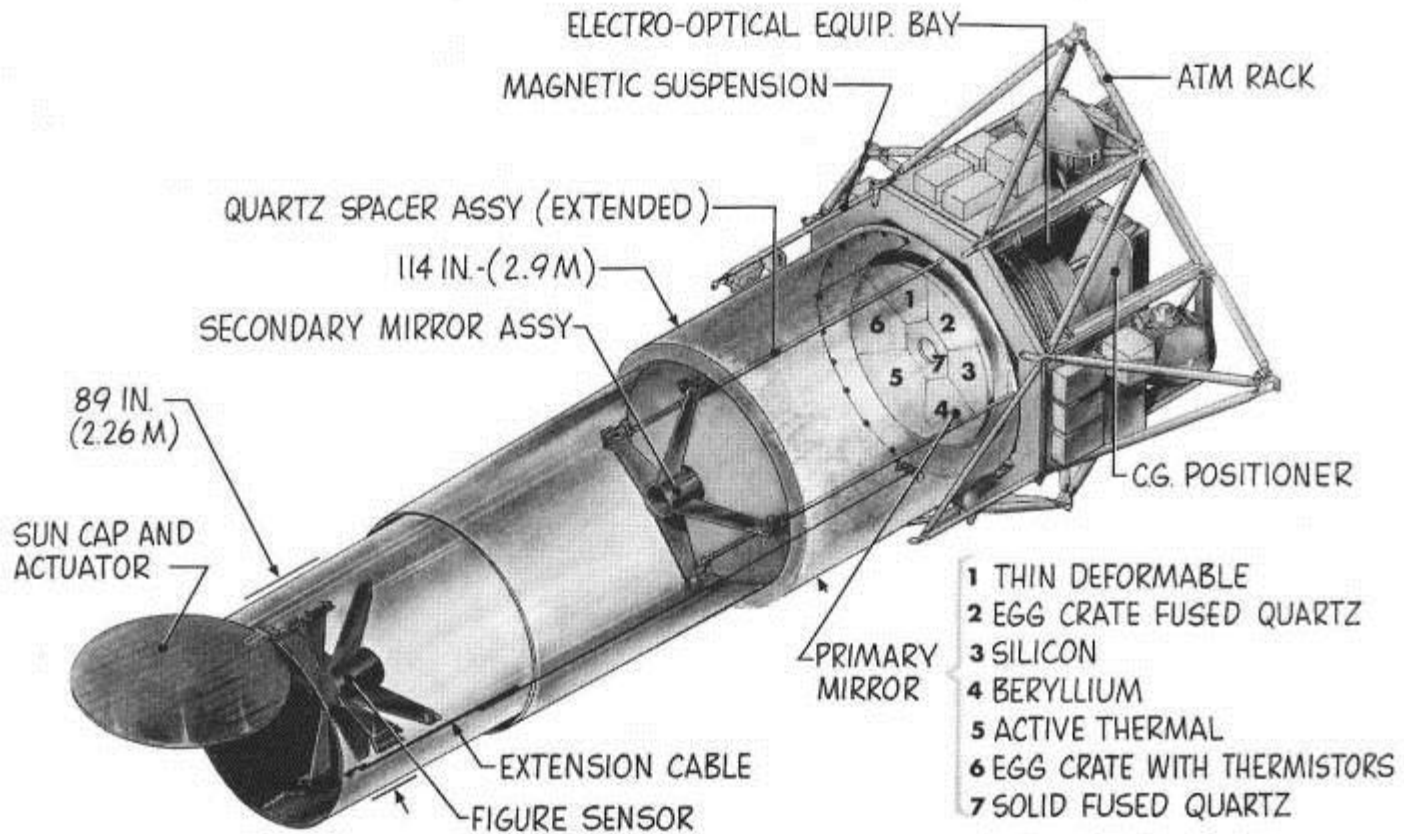



“3-meter Configuration Study Final Briefing”, Perkin-Elmer, May 1971

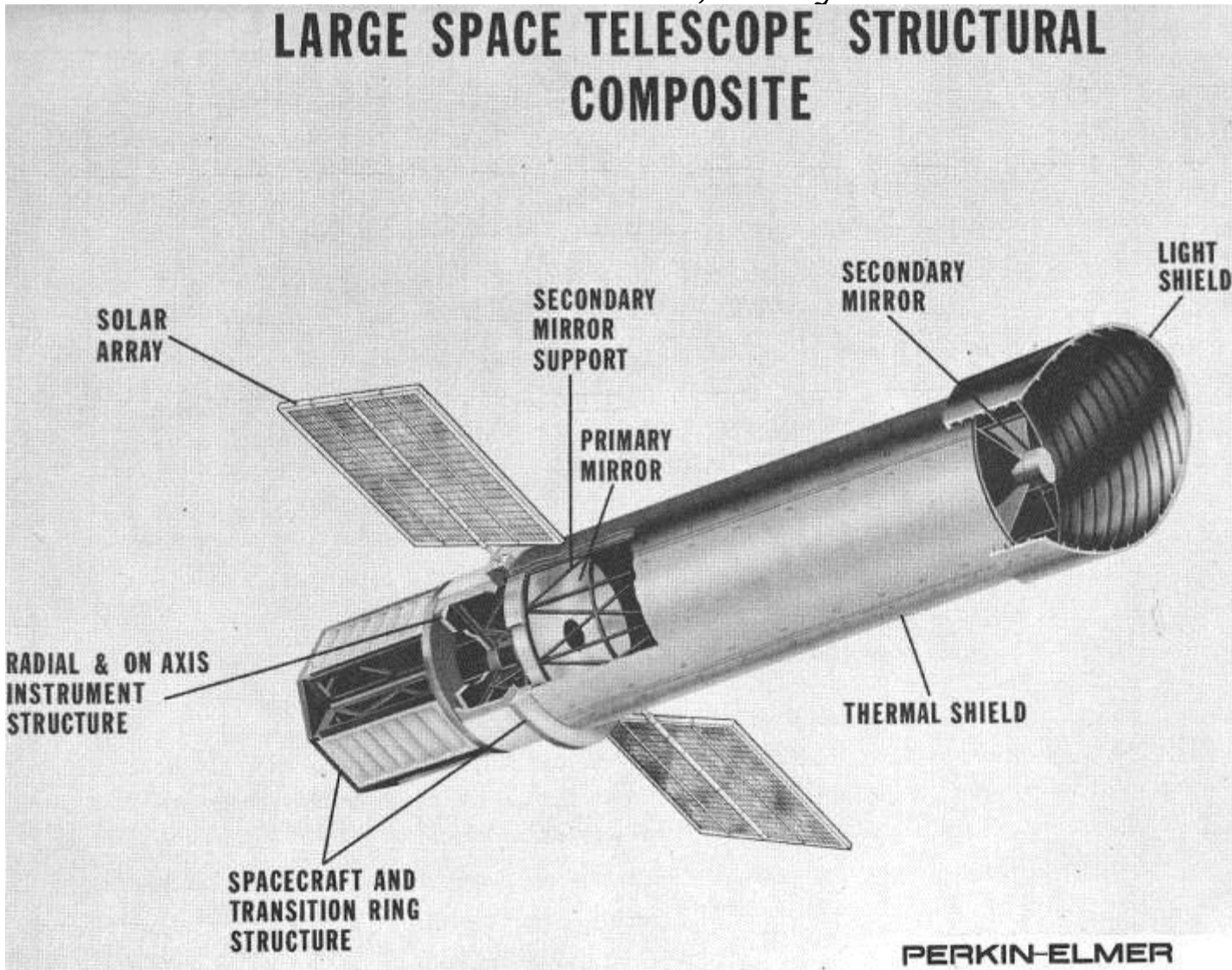

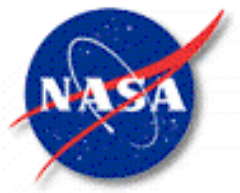

Hubble Deployment April 25 1990





Next Generation Space Telescope Study

In 1996 (based on the 1989 Next Generation Space Telescope workshop and the 1996 HST & Beyond report) NASA initiated a feasibility study.

Science Drivers

Near Infrared	1-5 microns (.6-30 extended)
Diffraction Limited	2 microns
Temperature range	30-60 Kelvin
Diameter	At least 4 meters (“HST and Beyond” report)

Programmatic Drivers

25 % the cost of Hubble	Cost cap - \$500 million
25 % the weight of Hubble	Weight cap ~3,000 kg

Baselines for OTA study

Atlas IIAS launch vehicle	Low cost launch vehicle
L2 orbit	Passively cool to 30-60 K
1000 kg OTA allocation	Launch vehicle driven



Study Results

Science requires a 6 to 8 meter space telescope, diffraction limited at 2 micrometers and operating at below 50K.

Segmented Primary Mirror

The only way to put an 8-meter telescope into a 4.5 meter fairing is to segment the primary mirror.

Mass Constraint

Because of severe launch vehicle mass constraint, the primary mirror cannot weight more than 1000 kg for an areal density of $< 20 \text{ kg/m}^2$

Such mirror technology did not exist



Reference design – Lockheed / Raytheon

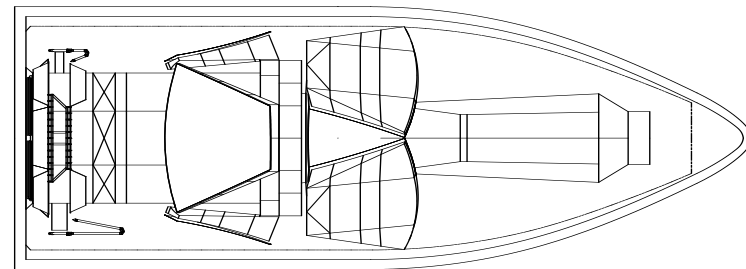
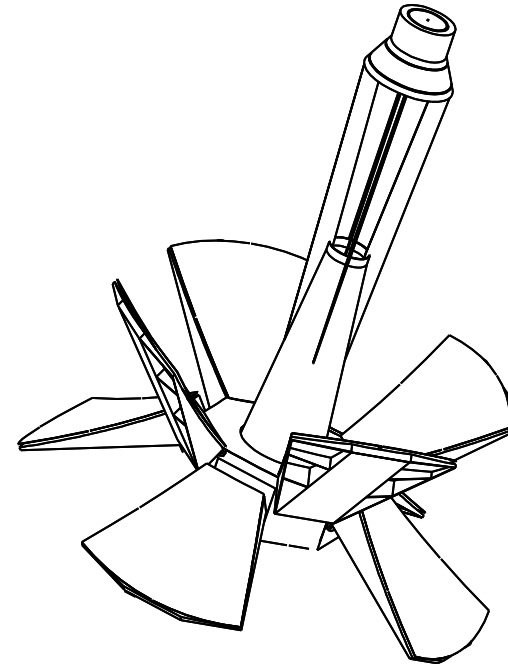
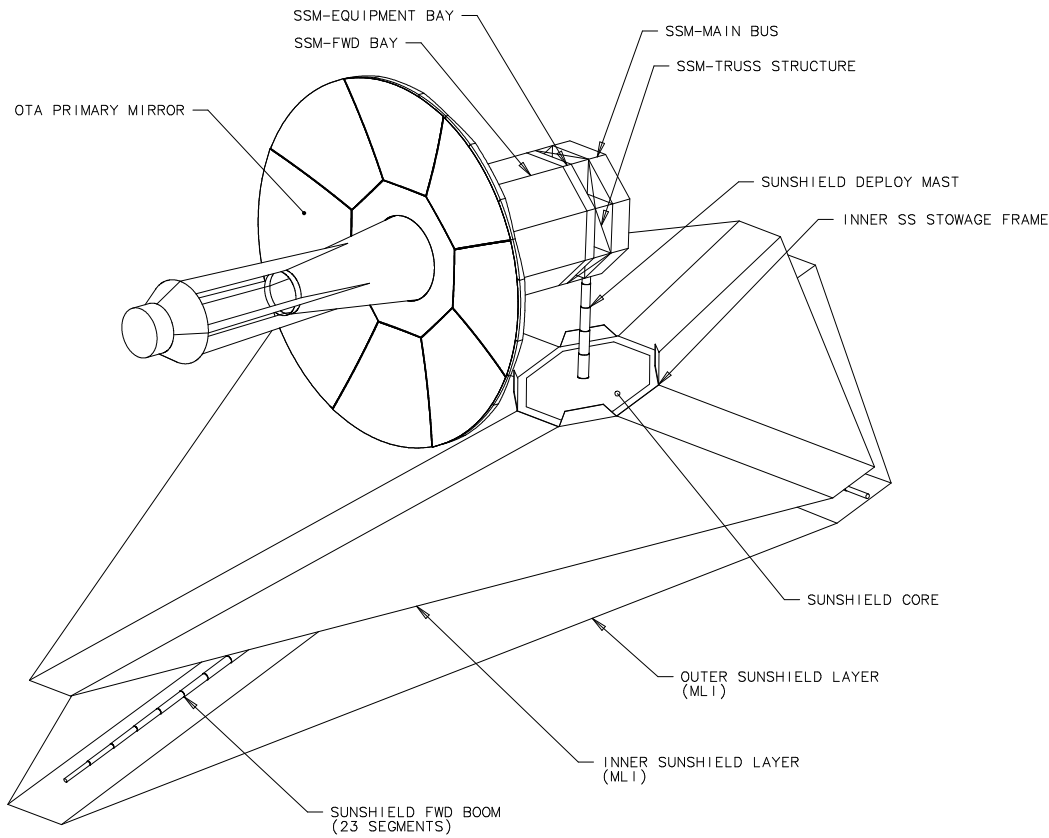

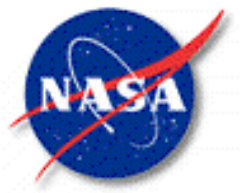

Reference design – TRW/Ball

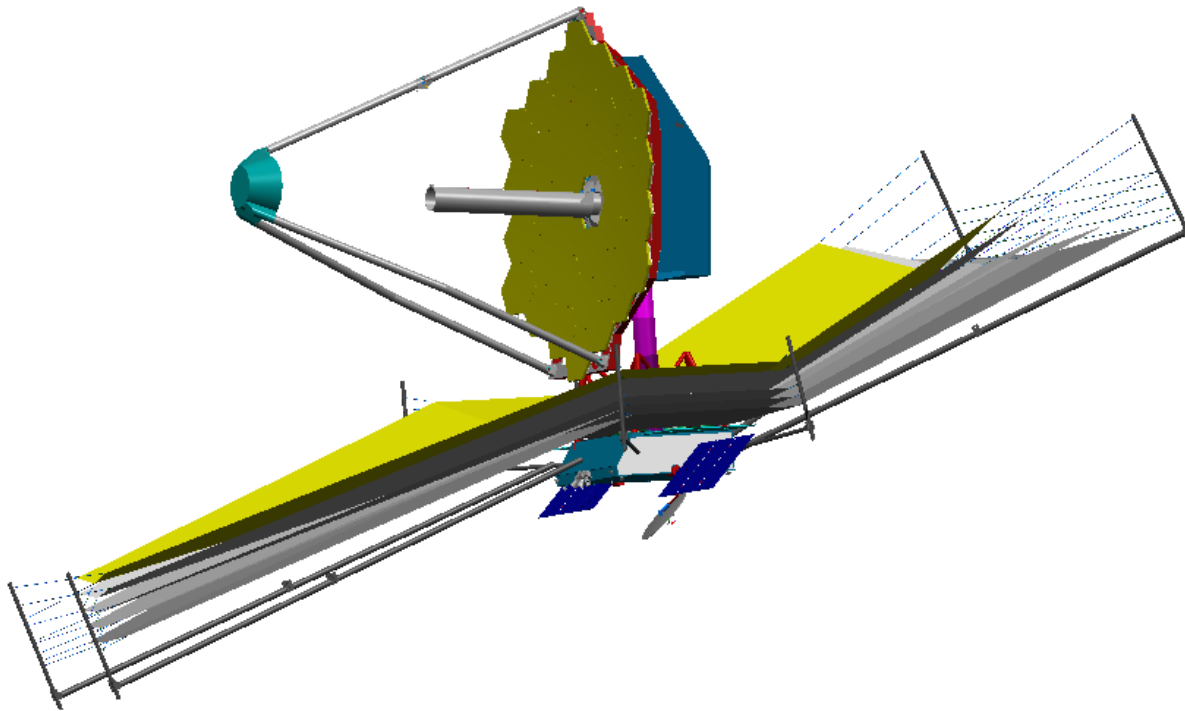



LAMP Telescope - 1996



Optical Specifications

4 meter diameter

10 meter radius of curvature

7 segments

17 mm facesheet

140 kg/m² areal density

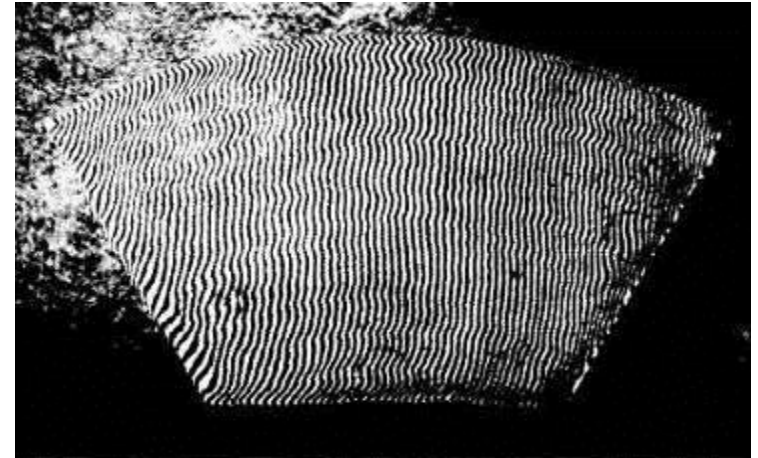
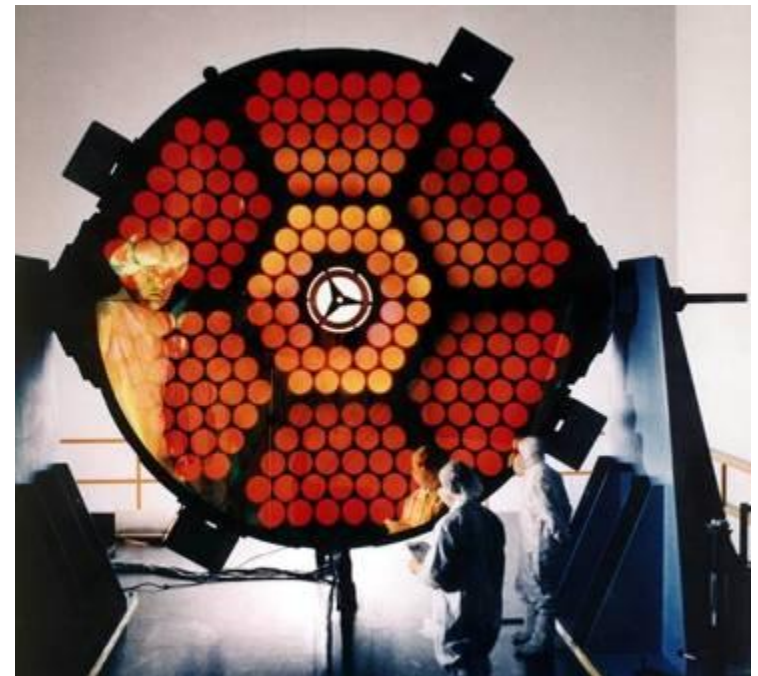
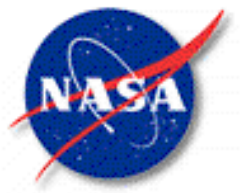

Fig. 12. Facesheet 3 final interferogram





ALOT Telescope - 1994



Optical Specifications

4 meter diameter

Center & one Outer Petal

70 kg/m² areal density

Active Figure and Piston Control

Eddy Current

Wavefront Sensor

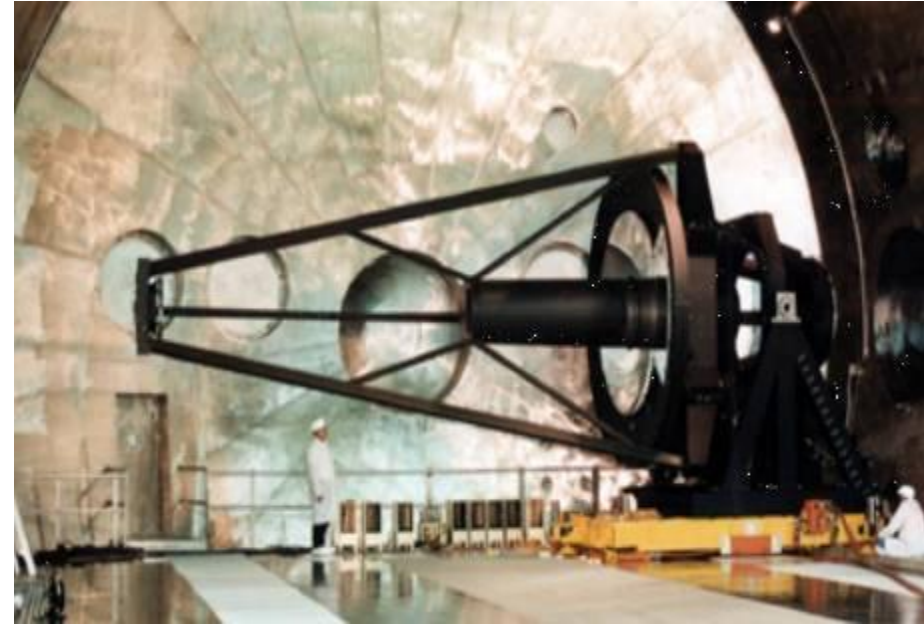

Phased two segment performance of 35 nm rms surface



Keck Telescope - 1992

10 meter diameter

36 segments

Capacitance Edge Sensors

Diffraction Limited ~ 10 micrometers

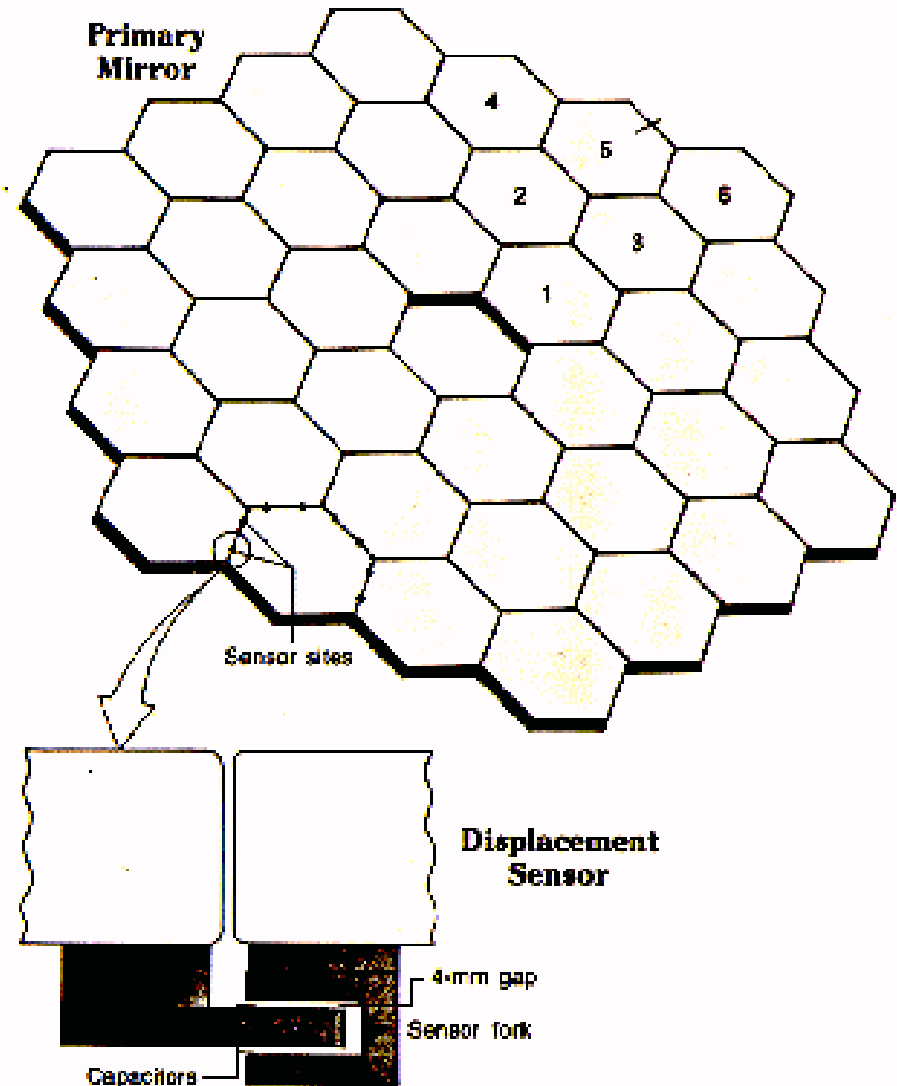
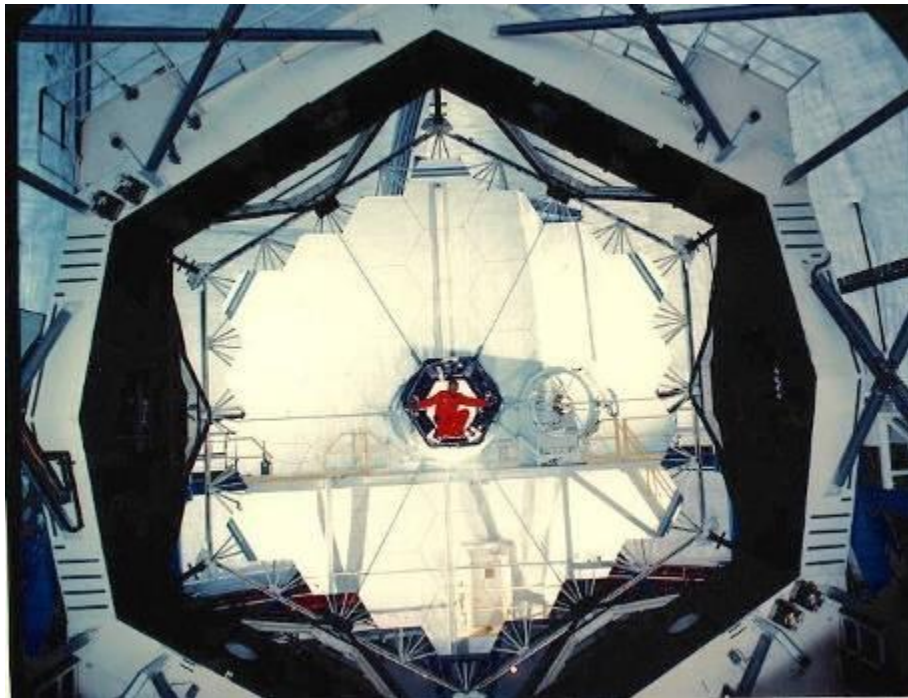



Programmatic Challenge of NGST

In 1996, the ability to affordably make NGST did not exist.

Substantial reductions in ability to rapidly and cost effectively manufacture low areal density mirrors were required.

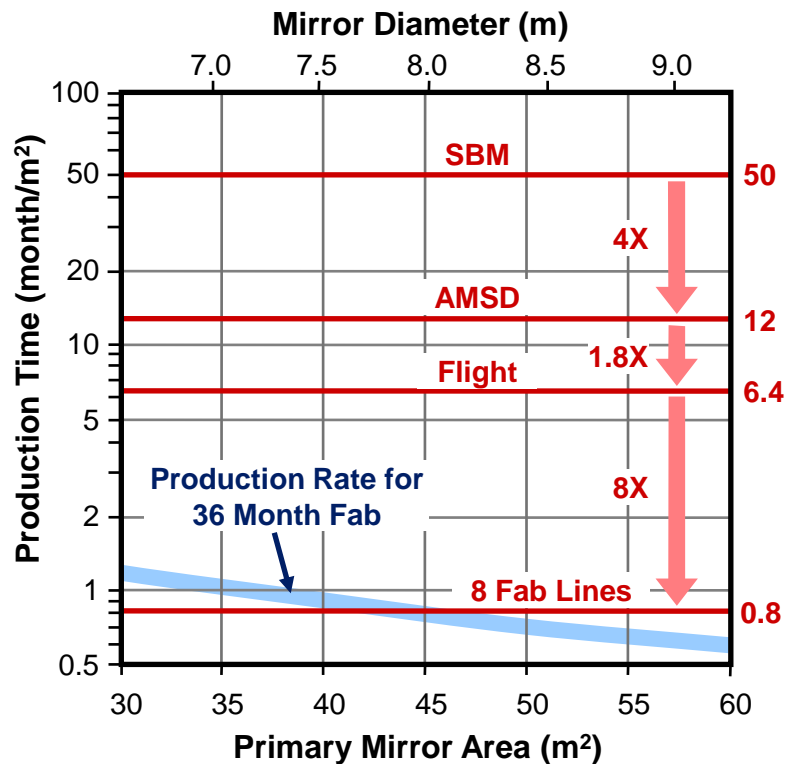
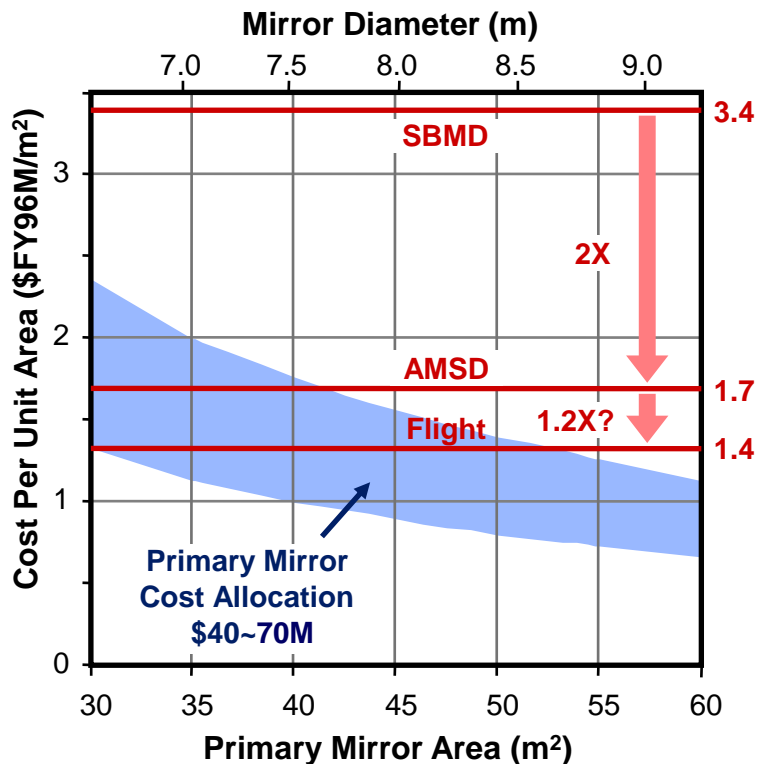



Technical Challenges of NGST

Assessment of pre-1996 state of art indicated that necessary mirror technology (as demonstrated by existing space, ground and laboratory test bed telescopes) was at TRL-3

1996 JWST Optical System Requirements State of Art						
Parameter	JWST	Hubble	Spitzer	Keck	LAMP	Units
Aperture	8	2.4	0.85	10	4	meters
Segmented	Yes	No	No	36	7	Segments
Areal Density	20	180	28	2000	140	kg/m ²
Diffraction Limit	2	0.5	6.5	10	Classified	micrometers
Operating Temp	<50	300	5	300	300	K
Environment	L2	LEO	Drift	Ground	Vacuum	Environment
Substrate	TBD	ULE Glass	I-70 Be	Zerodur	Zerodur	Material
Architecture	TBD	Passive	Passive	Hexapod	Adaptive	Control
First Light	TBD	1993	2003	1992	1996	First Light



The Spitzer Space Telescope



- ◆ Multi-purpose observatory cooled passively and with liquid-helium for astronomical observations in the infrared
- ◆ Launch in August 2003 for a 5+ year cryo mission in solar orbit, followed by 5-year “warm” mission
- ◆ Three instruments use state-of-the-art infrared detector arrays, 3-180um
- ◆ Provides a >100 fold increase in infrared capabilities over all previous space missions
- ◆ Completes NASA’s Great Observatories
- ◆ An observatory for the community - 85% of observing time is allocated via annual Call for Proposal



**Assembled SIRTF Observatory
at**

Lockheed-Martin, Sunnyvale.

Key Characteristics:

Aperture – 85 cm

Wavelength Range - 3-to-180um

Telescope Temperature – 5.5K

Mass – 870kg

Height – 4m



When I joined NASA is 1999, the over riding mantra for Space Telescopes was Areal Density, Cost & Schedule

Challenges for Space Telescopes:

Areal Density to enable up-mass for larger telescopes.

Cost & Schedule Reduction.

Are order of magnitude beyond 1996 SOA

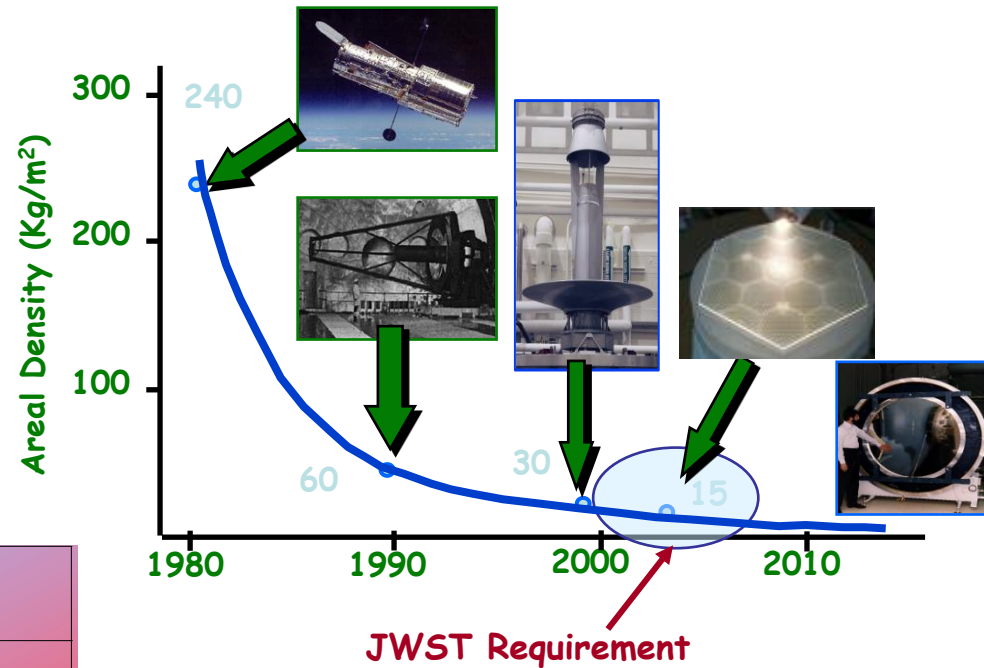

● = Demonstrated Hardware

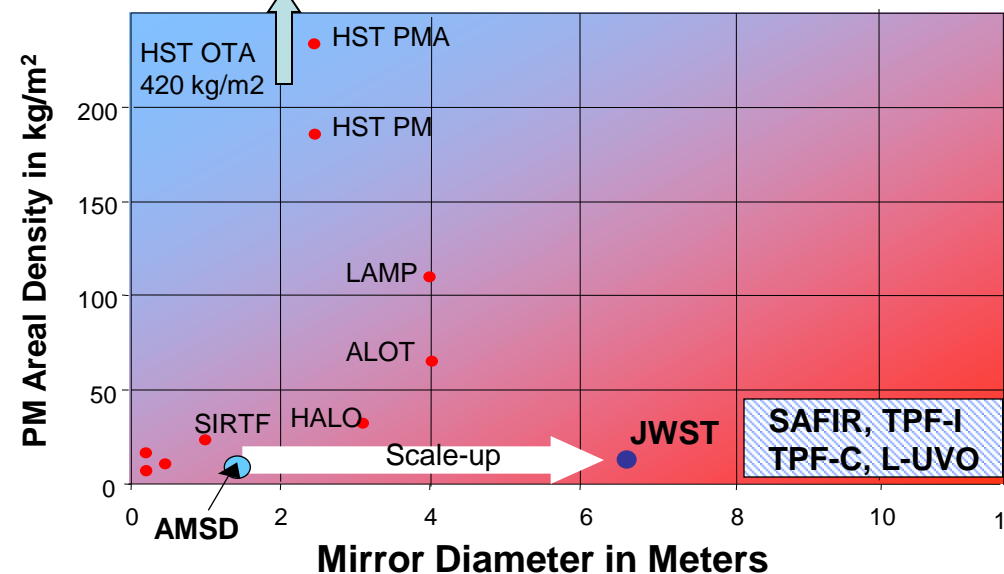

Primary Mirror	Time & Cost	
HST (2.4 m)	≈ 1 m ² /yr	≈ \$10M/m ²
Spitzer (0.9 m)	≈ 0.3 m ² /yr	≈ \$10M/m ²
AMSD (1.2 m)	≈ 0.7 m ² /yr	≈ \$4M/m ²
JWST (8 m)	> 6 m ² /yr	< \$3M/m ²

Note: Areal Cost in FY00 \$

Although I've come to think that Stiffness and Areal Cost are more important



The Role of Technology

An aggressive \$300M technology development program was initiated to change the cost paradigm for not only telescopes but also for detectors and instruments.

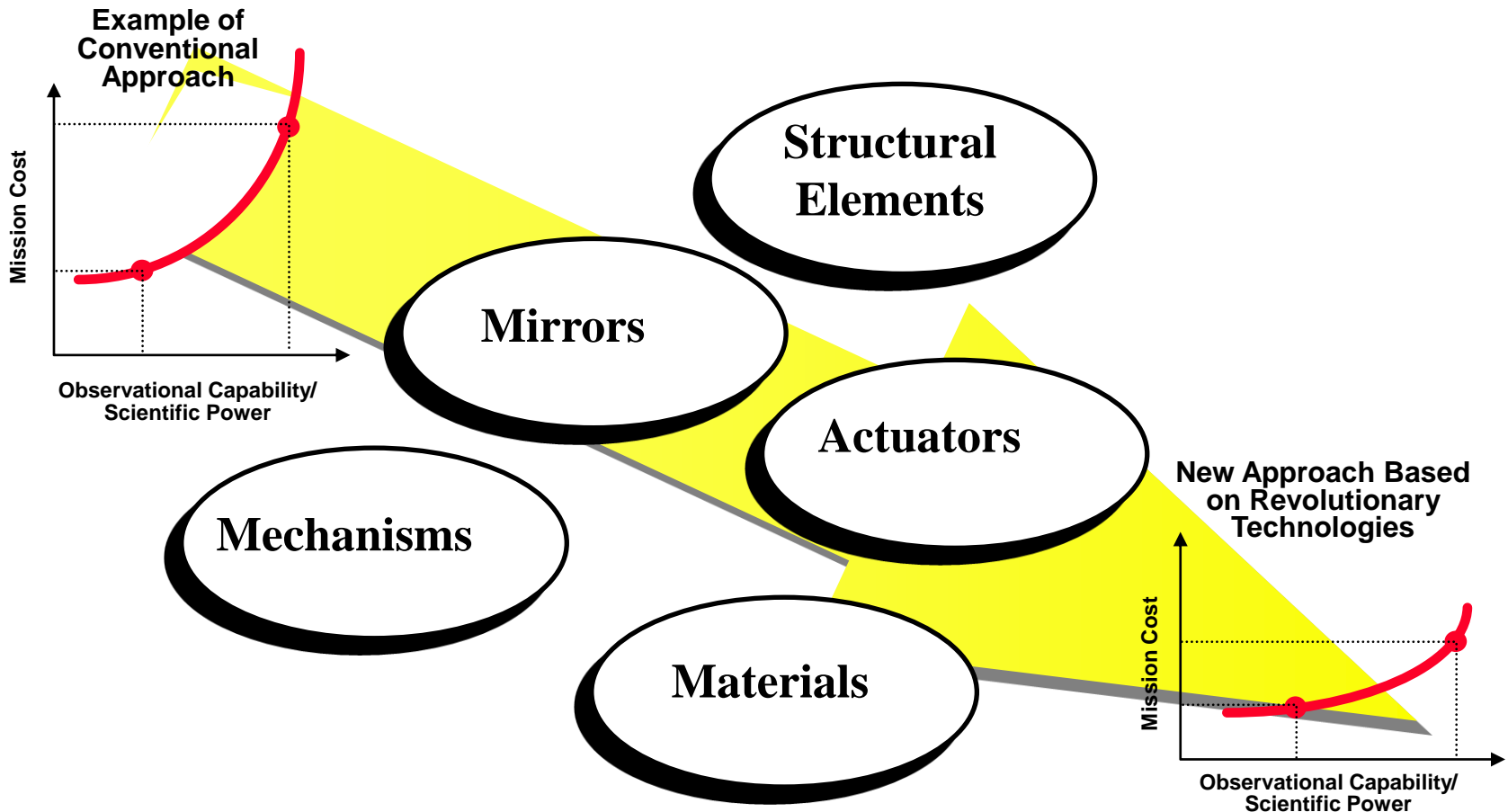



Mirror Technology Development

A systematic \$40M+ development program was undertaken to build, test and operate in a relevant environment directly traceable prototypes or flight hardware:

- Sub-scale Beryllium Mirror Demonstrator (SBMD)
- NGST Mirror System Demonstrator (NMSD)
- Advanced Mirror System Demonstrator (AMSD)
- JWST Engineering Test Units (EDU)

Goal was to dramatically reduce cost, schedule, mass and risk for large-aperture space optical systems.

A critical element of the program was competition – competition between ideas and vendors resulted in:

- remarkably rapid TRL advance in the state of the art
- significant reductions in the manufacturing cost and schedule

It took 11 years to mature mirror technology from TRL 3 to 6.

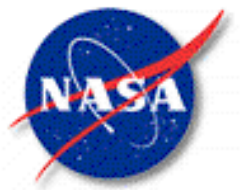

Enabling Technology

It is my personal assessment that there was 4 key Technological Breakthroughs which have enabled JWST:

- O-30 Beryllium (funded by AFRL)
- Incremental Improvements in Deterministic Optical Polishing
- Metrology Tools (funded by MSFC)
 - PhaseCAM Interferometer
 - Absolute Distance Meter
- Advanced Mirror System Demonstrator Project (AMSD)
 - funded by NASA, Air Force and NRO



Substrate Material



O-30 Beryllium enabled JWST

Spitzer used I-70 Beryllium while JWST uses O-30 Beryllium.

O-30 Beryllium (developed by Brush-Wellman for Air Force in late 1980's early 1990's) has significant technical advantages over I-70 (per Tom Parsonage)

Because O-30 is a spherical powder material:

- It has very uniform CTE distribution which results in a much smaller cryo-distortion and high cryo-stability
- It has a much higher packing density, thereby providing better shape control during HIP'ing which allows for the manufacture of larger blanks than what could be produced for Spitzer with I-70.

Because O-30 has a lower oxide content:

- It provides a surface quality unavailable to Spitzer, both in terms of RMS surface figure and also in scatter.

Ability to HIP meter class blanks demonstrated in late 1990's for VLT Secondary.

Full production capability in sufficient quantities for JWST on-line in 1999/2000.

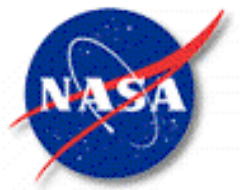

1960 Material Property Studies

PRIMARY MIRROR MATERIALS

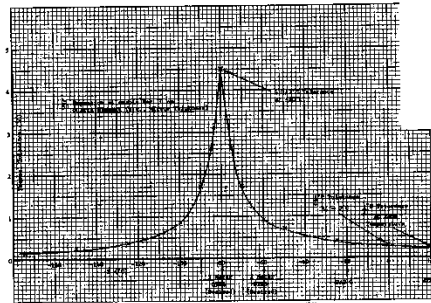

FUSED QUARTZ

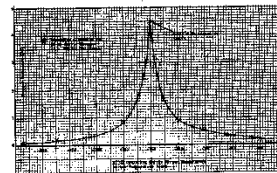
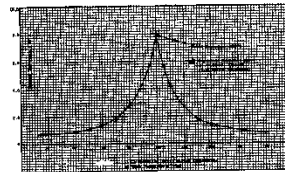

CERVIT

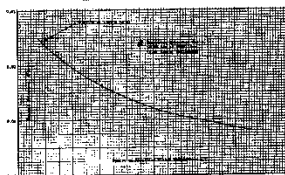
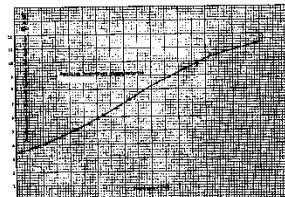

BERYLLIUM

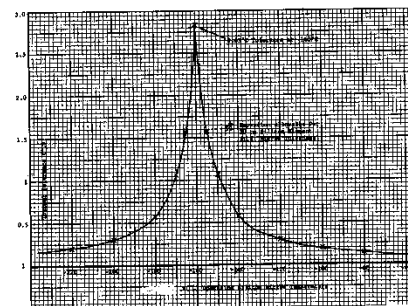

SILICON

PERKIN-ELMER



Thermal Stability was Significant Concern

THERMAL VACUUM TESTING
OF SPACE MIRRORS



OTES
EXPERIMENT 12

THERMAL VACUUM TESTING
OF SPACE MIRRORS

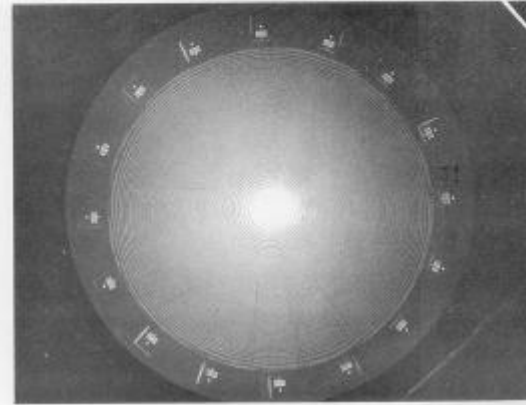

QUIESCENT

Mounting
Point

HEATED

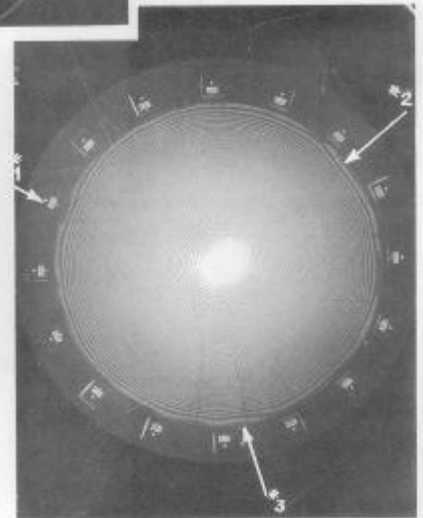

INSTRUMENTED
OAO MIRROR

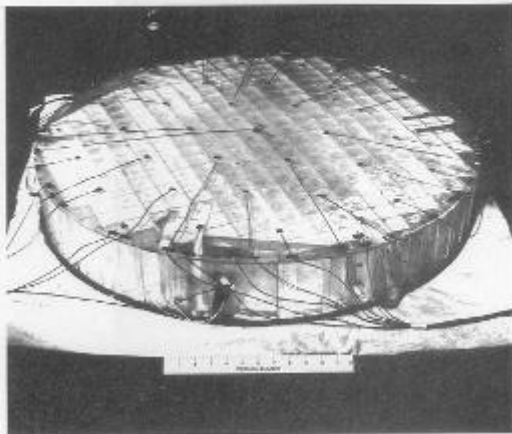



Solution to Thermal Instability was Segmented Mirror

SEGMENTED ACTIVE OPTICS

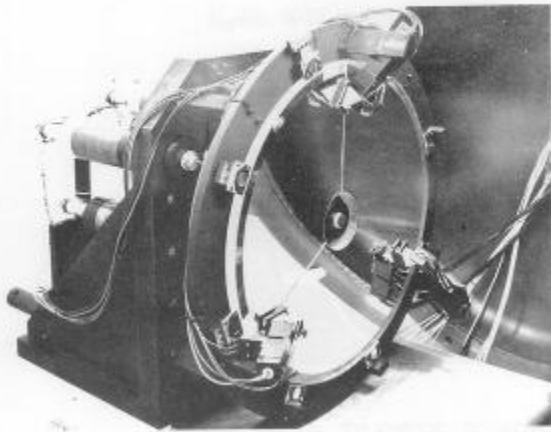

REFER TO
OTES
EXPERIMENT
NO. 1

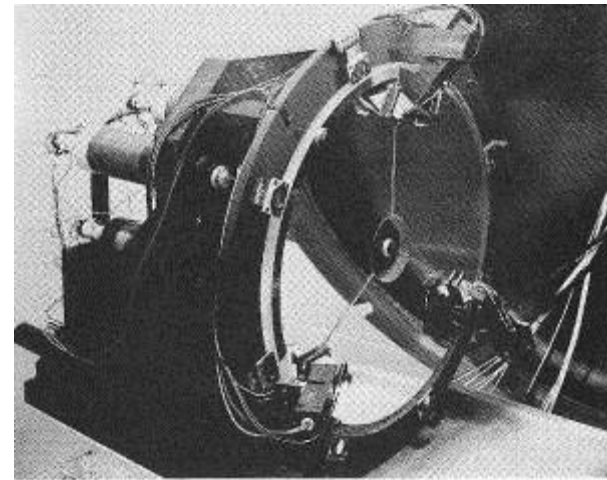

Segmented Mirror

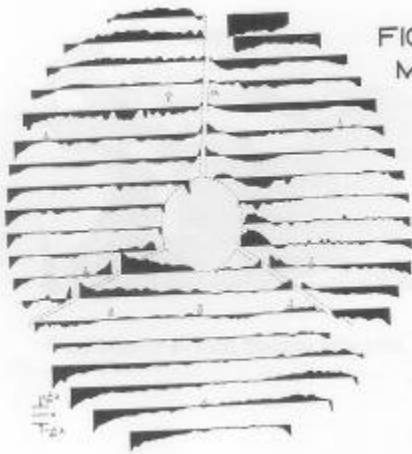
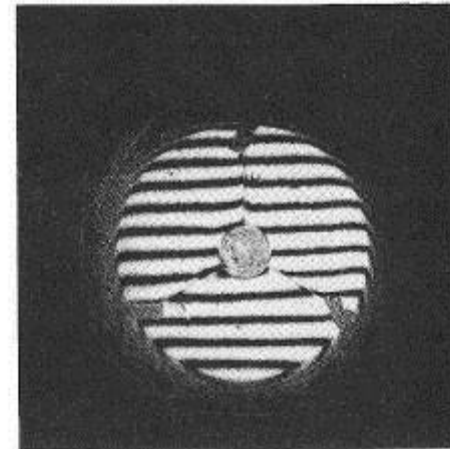
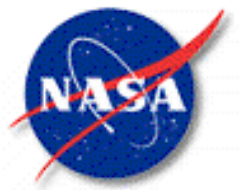

FIGURE ERROR MEASUREMENT

Raster Scan of
Figure Error for Composite
Active Optics Mirror with
Automatic Alignment in
Operation
Figure Error = $\pm 0.2 \mu m$



Interferogram of Active Segmented Mirror
Active Segmented Optics



Other Solution to Thermal Problem was Active Mirror

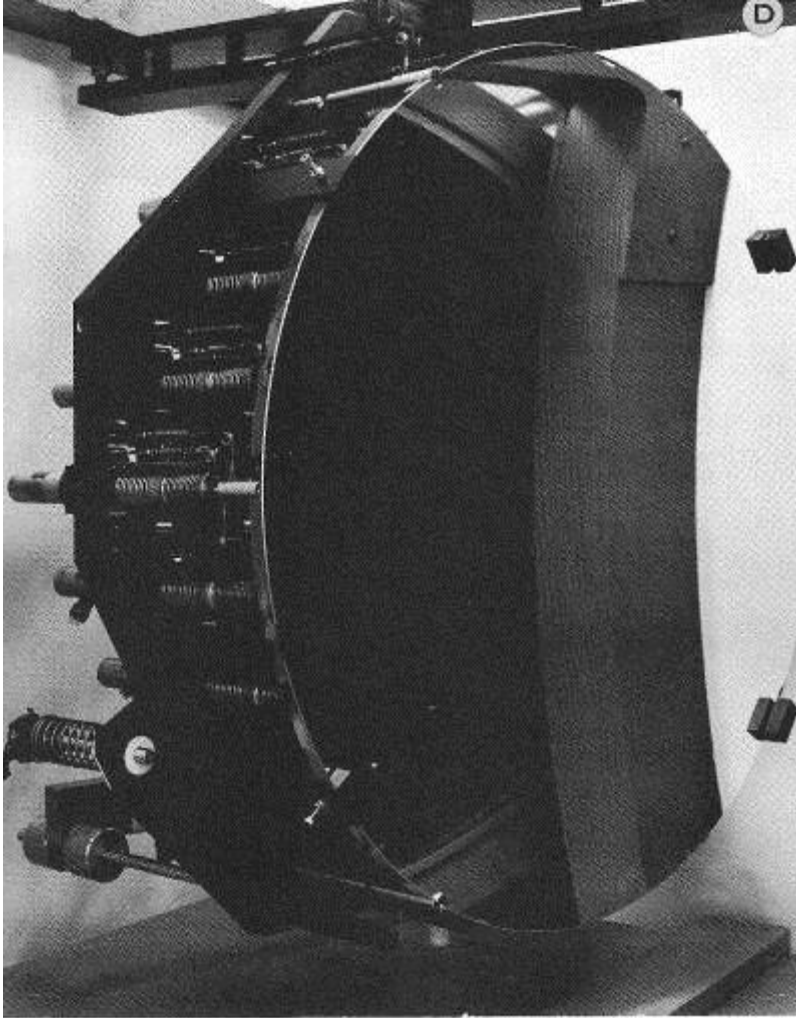

30 Inch Diameter Thin Deformable Mirror



This Deformable Mirror - Before Active Optics System Activated

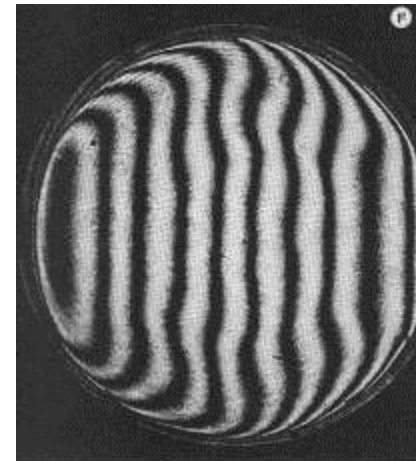

This Deformable Mirror - During Active Optics System Operation

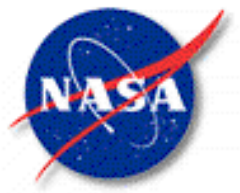

Final Solution was ...

The final solution was to develop better mirror materials:

Cervit,

ULE,

Zerodur

which enabled a passive monolithic space telescope mirror



Mirrors:

Substrate Technology & Optical Fabrication



Stratoscope II – Primary Mirror

1/25 rms wavefront

0.9 m diameter

277 kg/m²

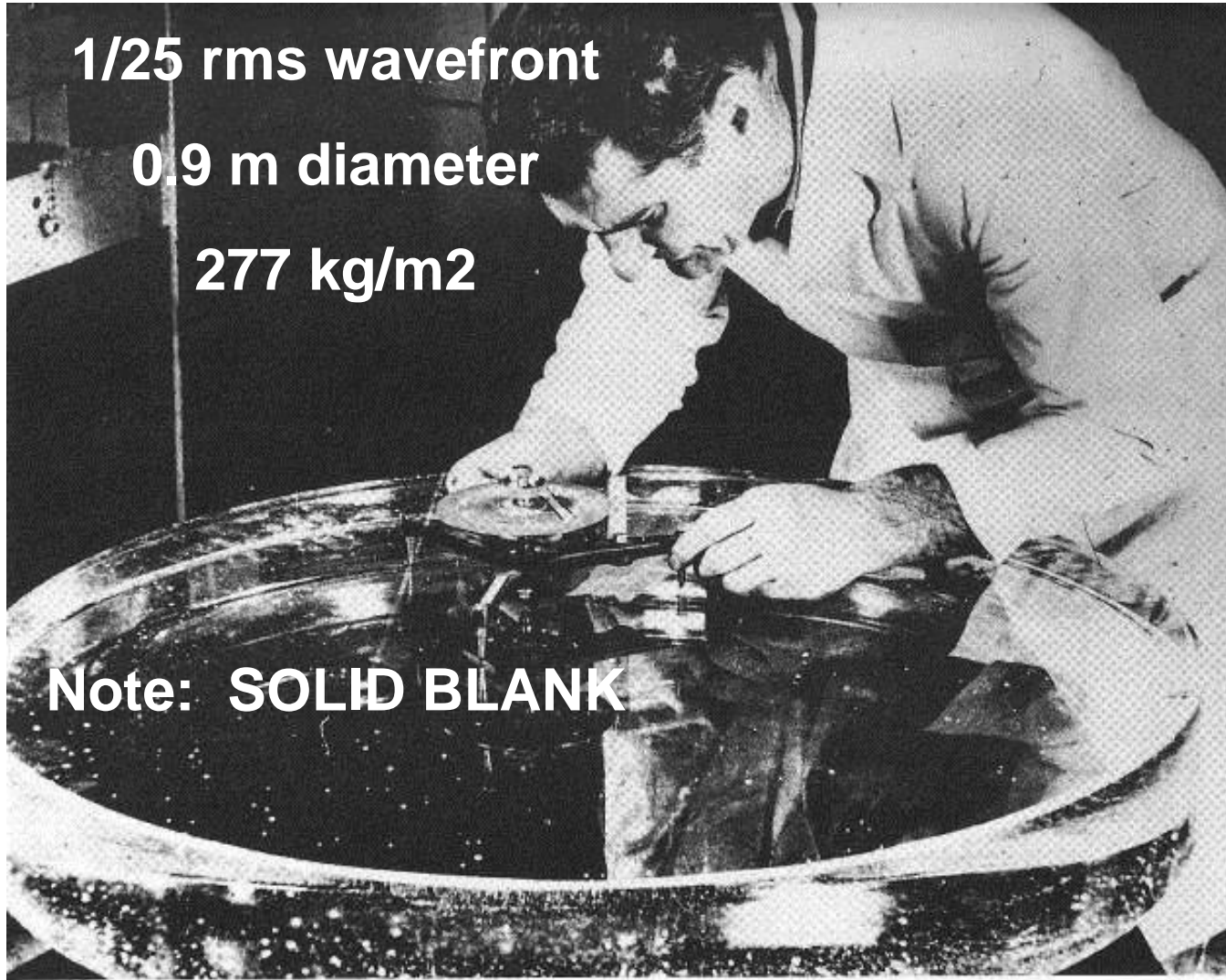

Note: **SOLID BLANK**

36-Inch Diameter Stratoscope II Mirror
Solid Fused Silica Blank 7940 - Weight 400 Pounds

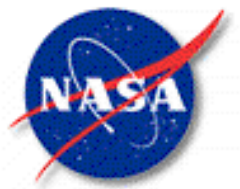

Stratoscope II – Optical Fabrication

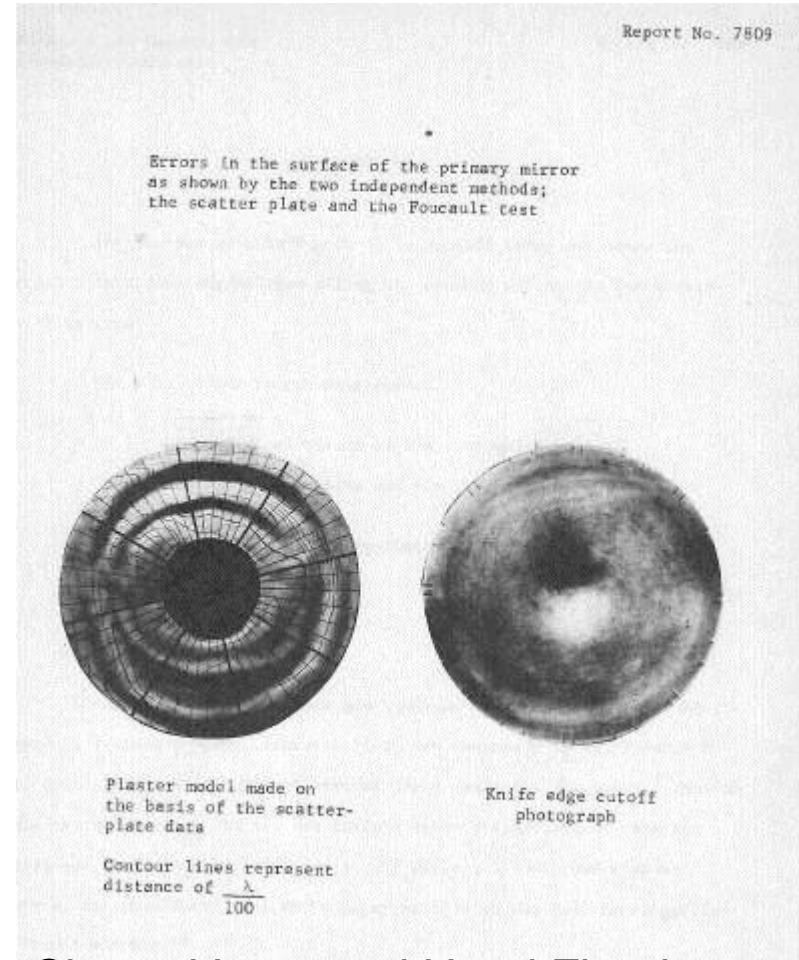
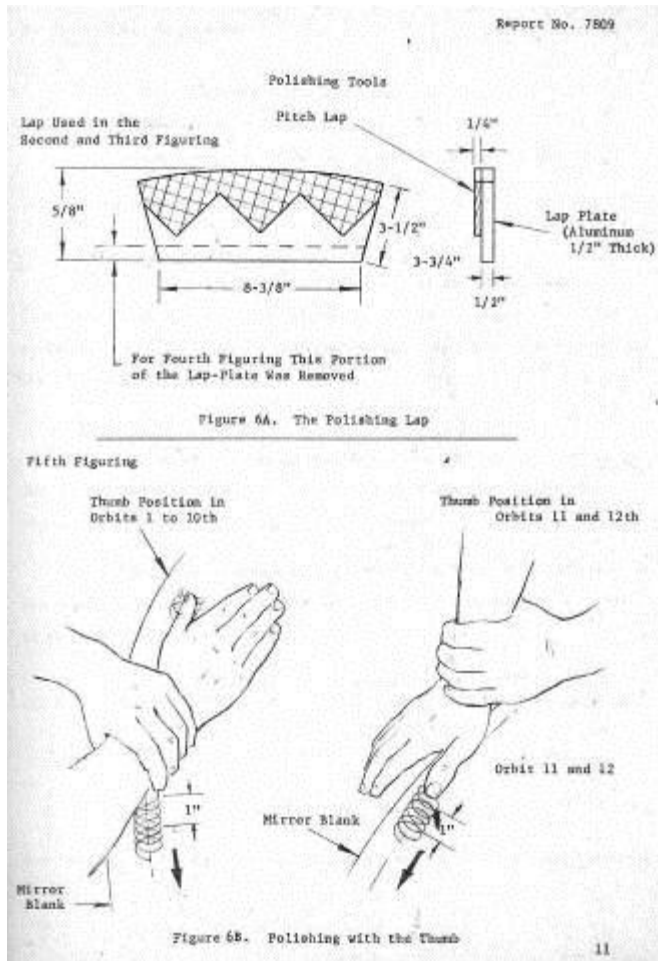

Classical Fabrication Techniques - Shaped Laps and Hand Figuring

“Test of the Primary and Secondary Mirrors for Stratoscope II”, Damant, Perkin-Elmer, Oct 1964.

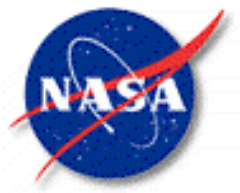

OA0-B Primary Mirror

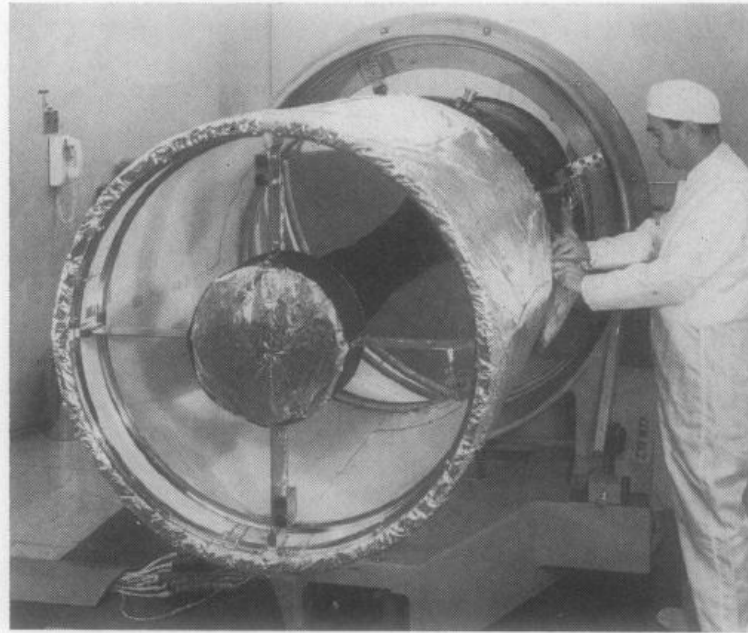
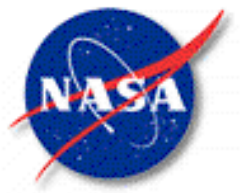

Fig. 1. View of the 38-inch GEP space telescope.

State of Art (6:1 solid blank) fused silica mirror would have had a mass of 310 kg (680 lbs).

Beryllium (S200B) thin meniscus (25:1) substrate with electroless nickel overcoat was fabricated. Its mass was 57 kg (125 lb). Its stiffness minimized gravity sag

“The Goddard Experiment Pacakage – an Automated Space Telescope”, Mentz and Jackson,, Kollsman Instrument Corp, IEEE Transactions of Aerospace and Electronic Systems, Vol. 5, No. 2, pp. 253, March 1969



OA0-C Primary Mirror



Fig. 4 Primary mirror before coating.

NASA is developing lightweight Egg-Crate Glass Mirror Substrates

“Princeton Experiment Package for OA0-C”, Norm Gundersen, Sylvania Electric Products Inc., J Spacecraft,
Vol. 5, No. 4, pp. 383, April 1968.

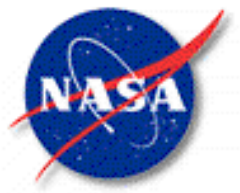

OA0-C Primary Mirror

0.8 meter diameter
1/5 rms wavefront
66% Lightweighted

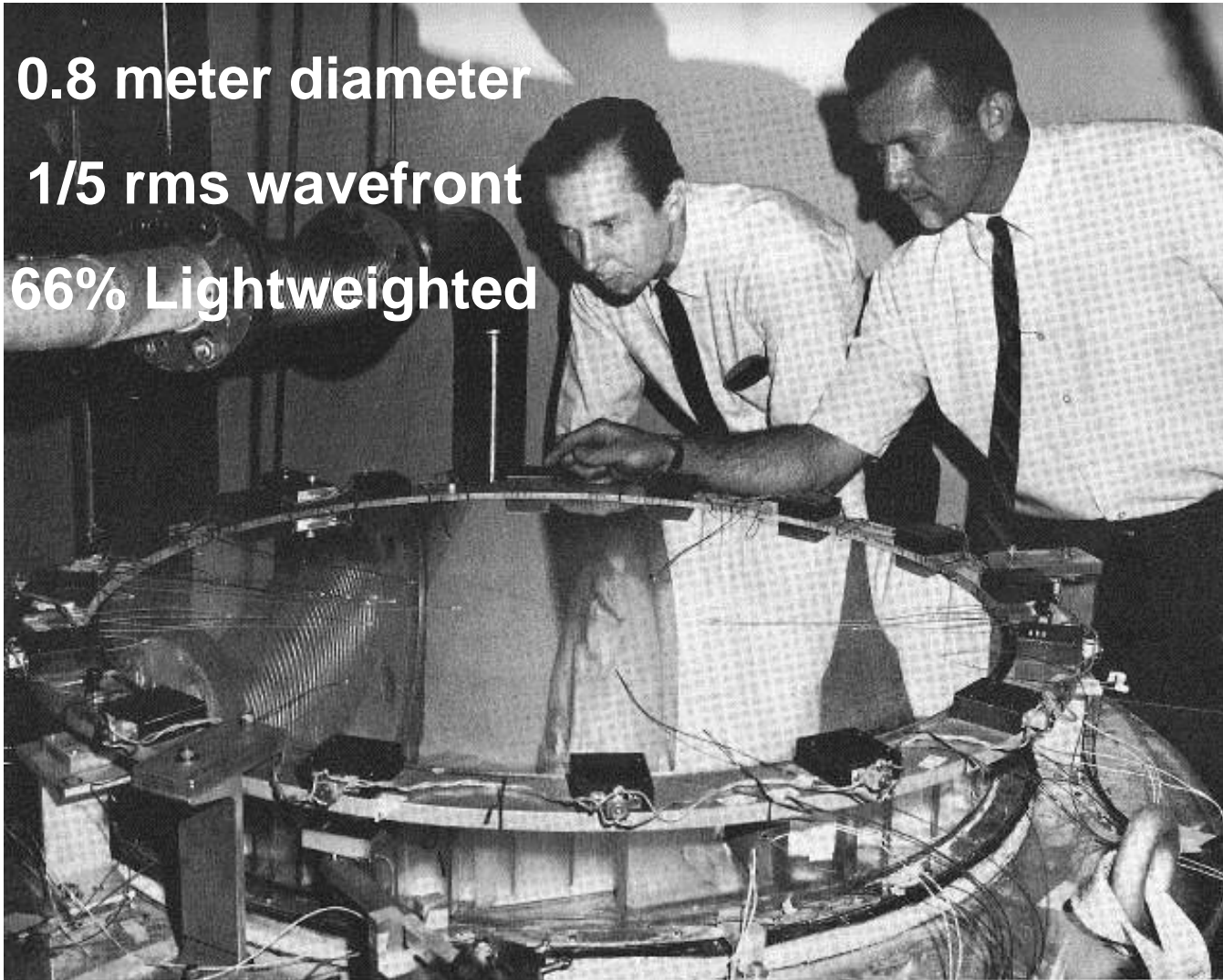

32 Inch Diameter OA0-C Princeton University Eggrate Mirror
(Thermal/Deformation Test Instrumentation)



Hubble Primary Mirror Fabrication 1979-81



Start of Small Tool Computer Controlled Polishing (I saw this)



Spitzer (ITTT) PM Fabrication



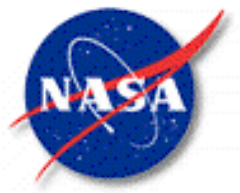

Spitzer PM Fabrication

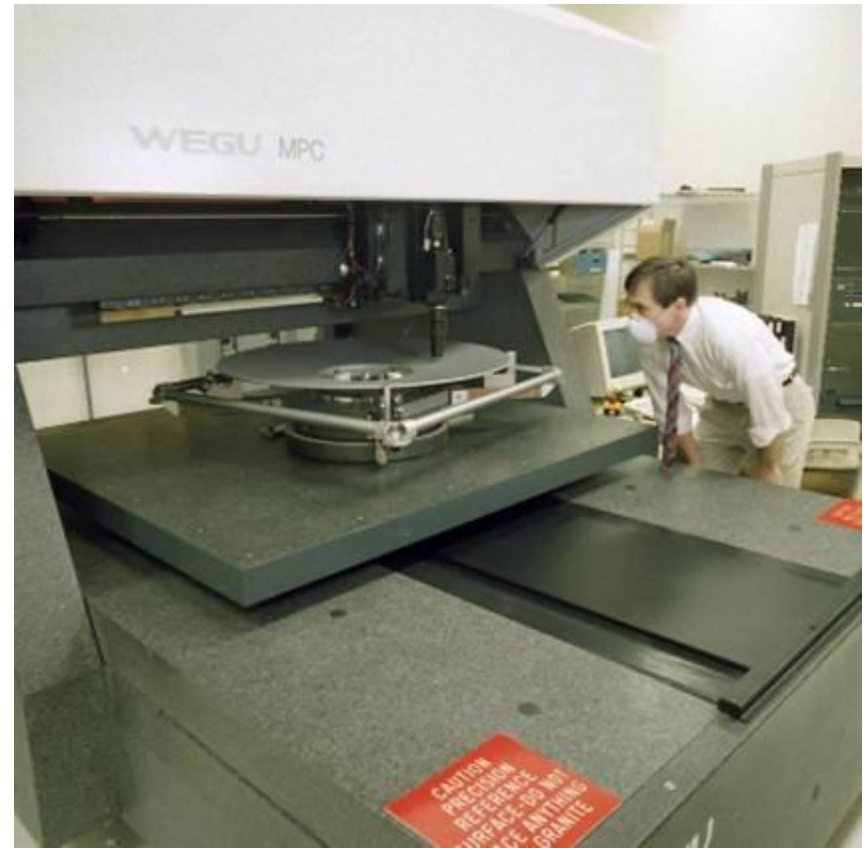

PM used Small Tool Computer Controlled Polishing

SM used Full Aperture Shaped Laps and Zonal Laps



Spitzer Optical Telescope Assembly and Primary Mirror

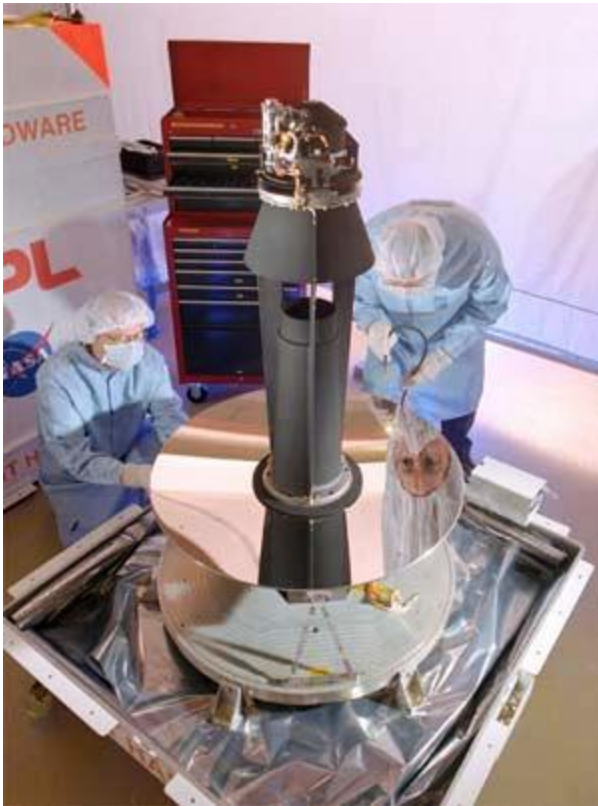

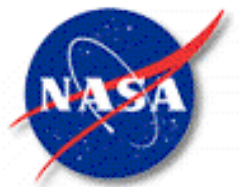

JWST Mirror Manufacturing Process

Blank Fabrication

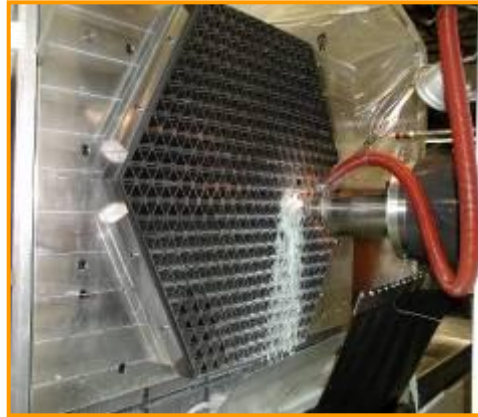

Machining

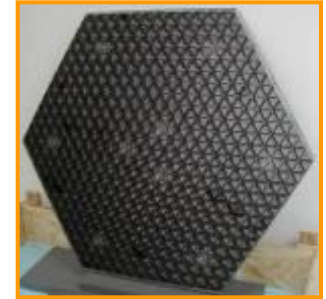

Completed Mirror Blank

HIP Vessel being loading into chamber

Machining of Web Structure

Machining of Optical Surface

Polishing

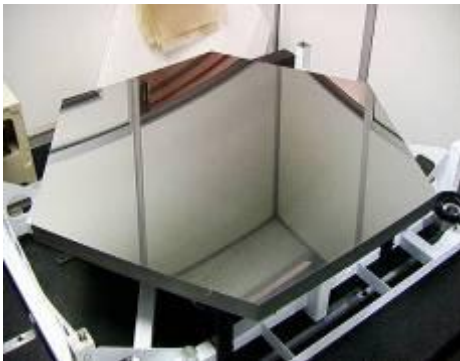

Mirror System Integration

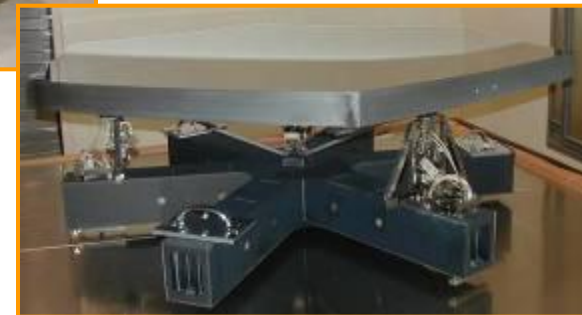
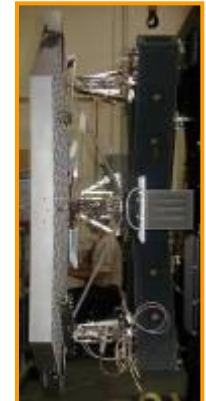



Mirror Fabrication at L-3 SSG-Tinsley

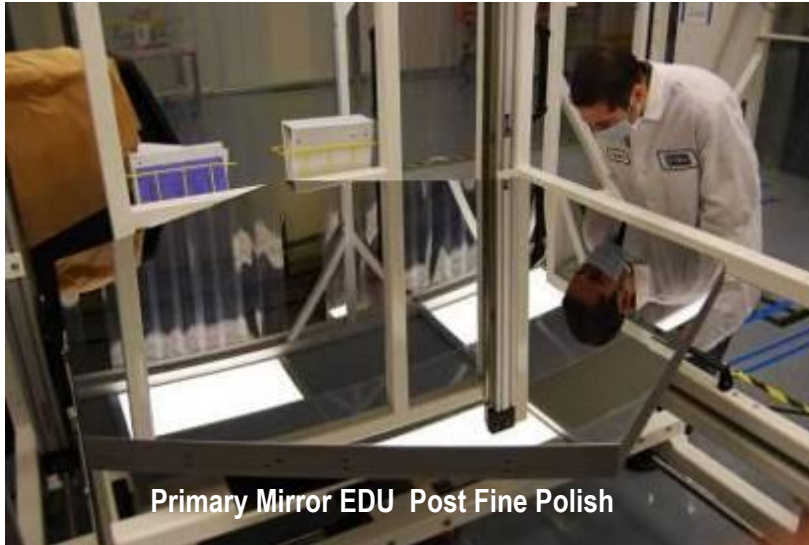

Primary Mirror EDU Post Fine Polish



SM in Rough Polish



TM in Rough Polish



EDU Shipped to BATC for Cryo Testing



Optical Testing



Optical Testing

you cannot make what you cannot measure

In 1999, the NGST program had a problem.

To produce cryogenic mirrors of sufficient surface figure quality, it was necessary to test large-aperture long-radius mirrors at 30K in a cryogenic vacuum chamber with a high spatial resolution interferometer.

The state of the art was temporal shift phase-measuring interferometers, e.g. Zygo GPI and Wyko.

Spatial resolution was acceptable, but mechanical vibration made temporal phase-modulation impossible.

But this problem is nothing new



Stratoscope II – Optical Testing

One solution is common path interferometry

Scatterplate Interferometer

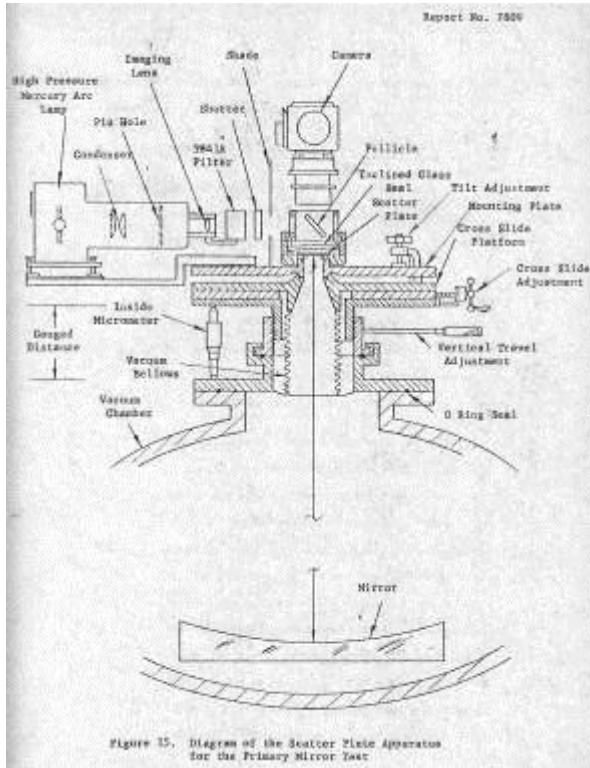

Fringe Scanning Digitizer

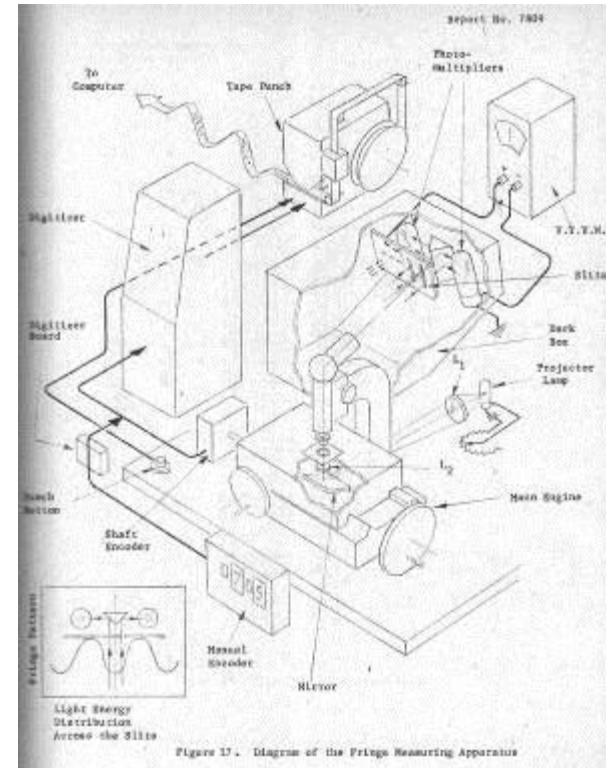

(And, in grad school I thought scatterplate interferometer was a laboratory curiosity.)

Testing support from J.M. Burch, A. Offner, J.C. Buccini and J. Houston

OAO-C also used scatter plate interferometry

“Test of the Primary and Secondary Mirrors for Stratoscope II”, Damant, Perkin-Elmer, Oct 1964.



Hubble Testing

Another solution is short exposure time.

Hubble optical testing (at both Perkin-Elmer and Kodak) was performed with custom interferometers taking dozens of film images which were digitized to produce a surface map.

- Camera Shutter Speed ‘freezes’ vibration/turbulence
- PE used custom micro-densitometer and Kodak manually digitized
- PE tested in the vertical ‘Ice-Cream Cone’ vacuum chamber

Even in the 1990’s when I worked at PE (then Hughes) I would hand digitize meter class prints of interferograms.

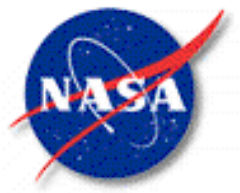

Hubble Primary Mirror Optical Testing

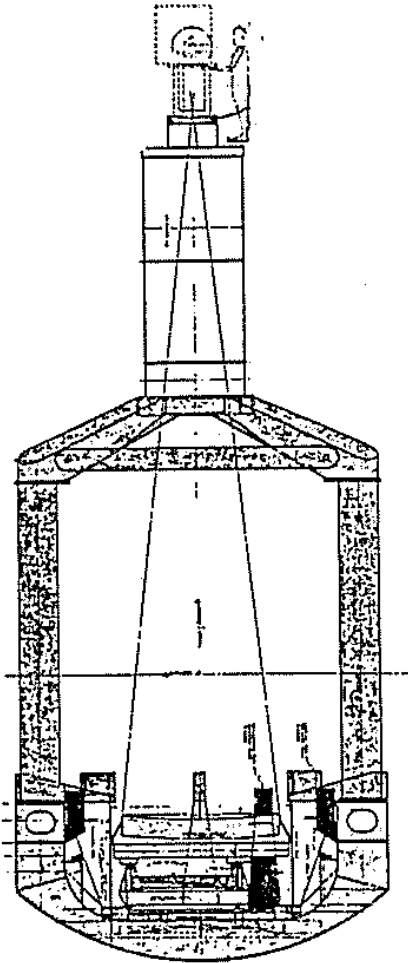

Figure 2. Primary mirror test configuration.



Hubble Interferogram Digitization & Analysis

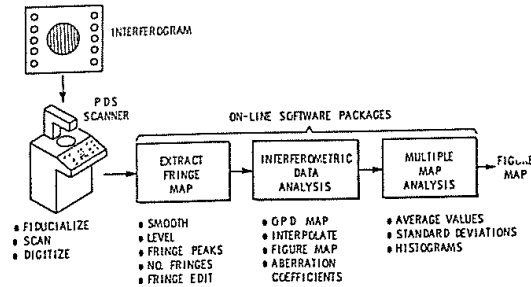

Figure 14. Interferogram analysis facility.

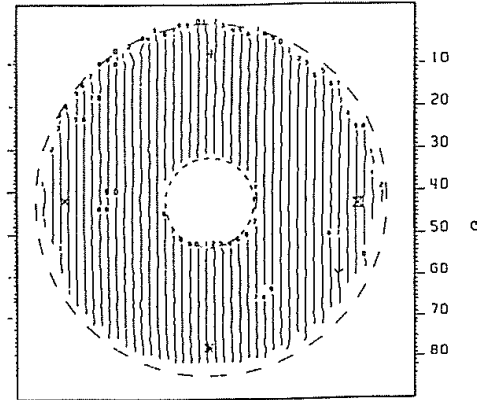
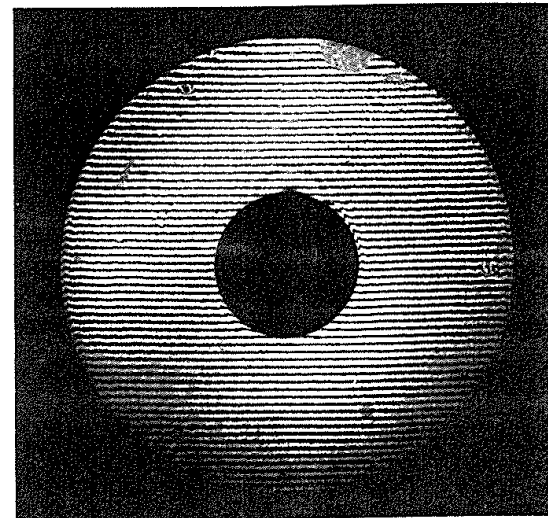

Figure 15. Fringe map.

1. 1.0000
2. 1.9157 R COS θ
3. 1.9157 R SIN θ
4. 3.8067 (R² - 0.5450)
5. 2.3375 (R² COS 2 θ)
6. 2.3375 (R² SIN 2 θ)
7. 8.3230 (R³ - 0.6716R) COS θ
8. 8.3230 (R³ - 0.6716R) SIN θ
9. 2.6982 (R³ COS 3 θ)
10. 2.6982 (R³ COS 3 θ)
11. 16.2014 (R⁴ - 1.0900R² + 0.2280)
12. 12.1216 (R⁴ - 0.7505R²) COS 2 θ
13. 12.1216 (R⁴ - 0.7505R²) SIN 2 θ
14. 3.0166 (R⁴ COS 4 θ)
15. 3.0166 (R⁴ SIN 4 θ)
16. 35.6508 (R⁵ - 1.2220R³ + 0.3166R) COS θ
17. 35.6508 (R⁵ - 1.2220R³ + 0.3166R) SIN θ
18. 16.5335 (R⁵ - 0.8000R³) COS 3 θ
19. 16.5335 (R⁵ - 0.8000R³) SIN 3 θ
20. 3.3045R⁵ COS 5 θ
21. 3.3045R⁵ SIN 5 θ
22. 70.2190 (R⁶ - 1.6350R⁴ + 0.7669R² - 0.0942)
23. 306.234 (R⁸ - 2.1800R⁶ + 1.60497R⁴ - 0.4541R² + 0.0392)

Figure 16. Annular Zernike polynomials for 0.3 obscuration.



06 1494-81

Figure 17. Interferogram of finished primary mirror masked to its clear aperture.



Spitzer Secondary Mirror Testing



Another solution is structurally connect interferometer and test.

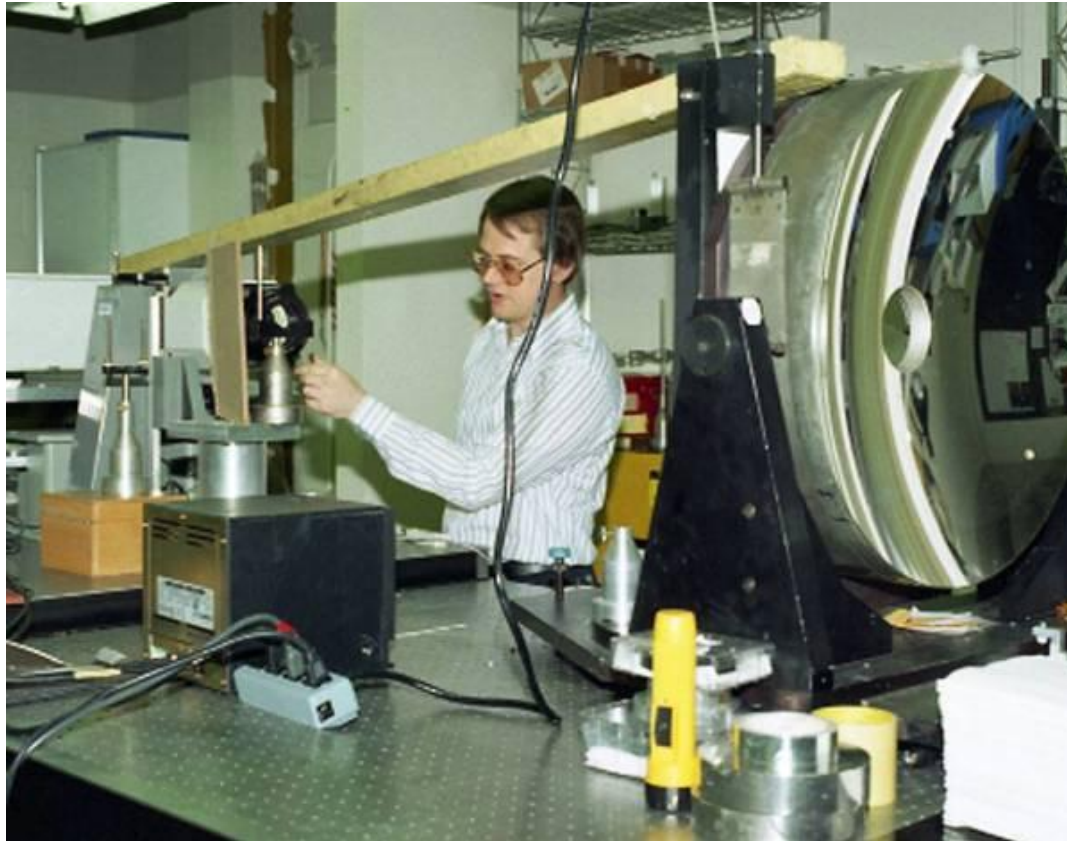

Spitzer (ITTT) Secondary Mirror Hindle Sphere Test Configuration using a Zygo GPI with Remote PMR Head.



PhaseCAM

At BRO, I designed, built and wrote the software for a 480 Hz common path phase-measuring Twyman-Green interferometer that was used to test all the Keck segments at ITEK.

As I prepared to leave Danbury for NASA, I was visiting Metrolaser where I saw a breadboard device taking phase-maps of a candle flame.

When I got to NASA I defined the specifications for and ordered the first PhaseCAM interferometer.

Today they are critical to JWST.



Tech Days 2001

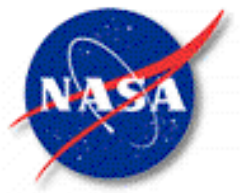

Mirror Technology Development Program

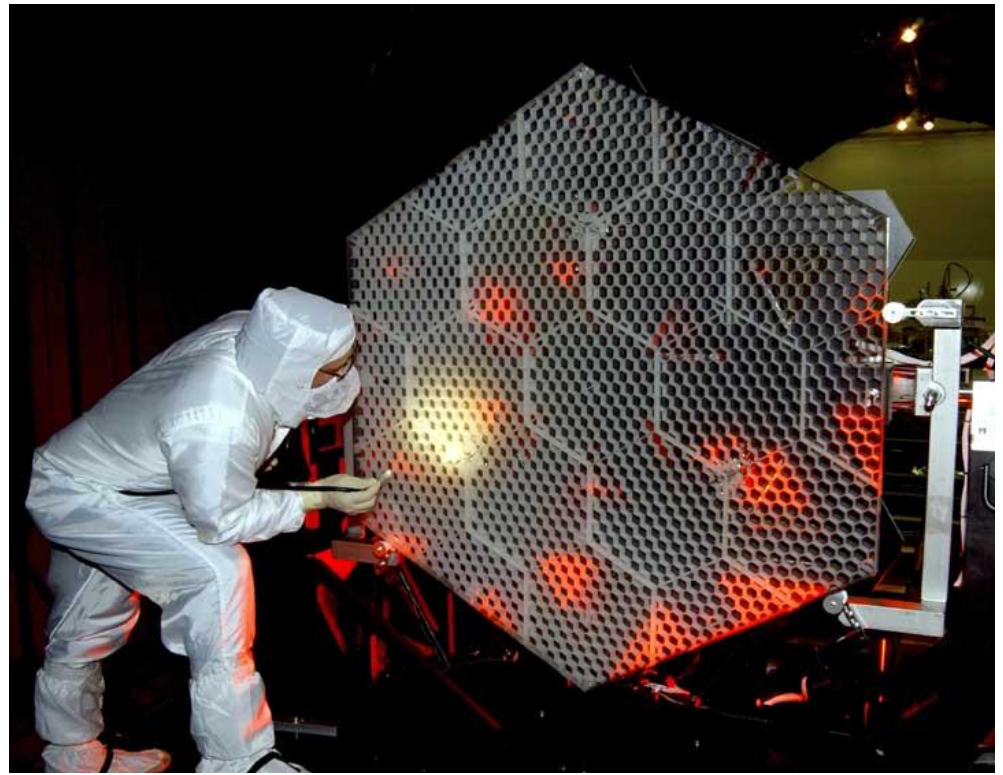

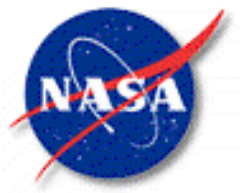

Mirror Technology Development

Systematic Study of Design Parameters

<u>Item</u>	<u>SBMD</u>	<u>NMSD</u>	<u>AMSD</u>
Form	Circle w Flat	Hex	Hex
Prescription	Sphere	Sphere	OAP
Diameter	>0.5 m	1.5 - 2 m	1.2 - 1.5 m
Areal Density	< 12+ kg/m ²	<15 kg/m ²	<15 kg/m ²
Radius	20 m	15 m	10 m
PV Figure	160 nm	160/63 nm	250/100 nm
RMS Figure			50/25 nm
PV Mid (1-10 cm ⁻¹)	63 nm	63/32 nm	
RMS Finish	3/2 nm	2/1 nm	4 /2 nm



Mirror Technology Development

Wide Variety of Design Solutions were Studied

<u>Item</u>	<u>SBMD</u>	<u>NMSD</u>	<u>AMSD</u>
Substrate Material	Be (Ball)	Glass (UA) Hybrid (COI)	Be (Ball) ULE Glass (Kodak) Fused Silica (Goodrich)
Reaction Structure	Be	Composite Composite (all)	
Control Authority	Low	Low (COI)Low (Ball) High (UA)	Medium (Kodak) High (Goodrich)
Mounting	Linear Flexure	Bipods (COI) 166 Hard (UA)	4 Displacement (Ball) 16 Force (Kodak) 37 Bi/Ax-Flex (Goodrich)
Diameter	0.53 m	2 m (COI) 1.6 m (UA)	1.3 m (Goodrich) 1.38 m (Ball) 1.4 m (Kodak)
Areal Density	9.8+ kg/m ²	13 kg/m ²	15 kg/m ²

JWST Mirror Technology History

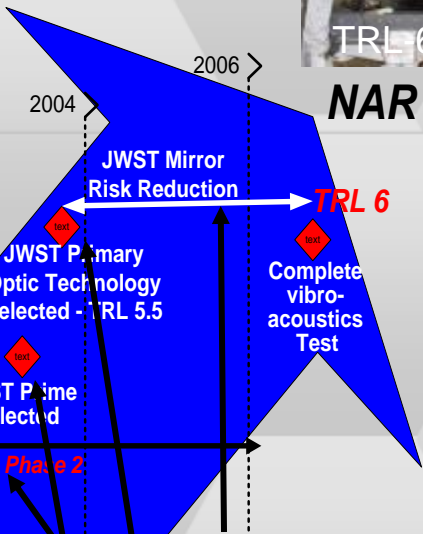

NASA HST, Chandra, SIRTf Lessons Learned
 - TRL 6 by NAR
 - Implement an active risk management process early in the program (Early investment)

Mirror Material/Technology Selection, September, 2003

- Beryllium chosen for technical reasons (cryogenic CTE, thermal conductance, issues with glass stress, issues with Be noted)

Prime Contractor Selection

- Ball (Beryllium) and ITT/Kodak (ULE) proposed as options, Goodrich dropped from AMSD (0.5 meter demonstrations)

Based on lessons learned, JWST invested early in mirror technology to address lower areal densities and cryogenic operations



Performance Characterization

Ambient and Cryogenic Optical Performance was measured at XRCF.

Each mirror tested multiple times below 30K

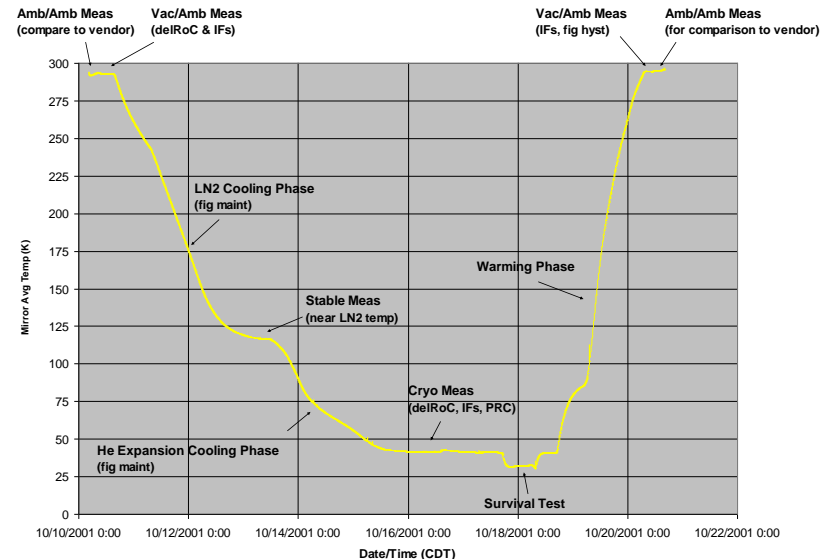
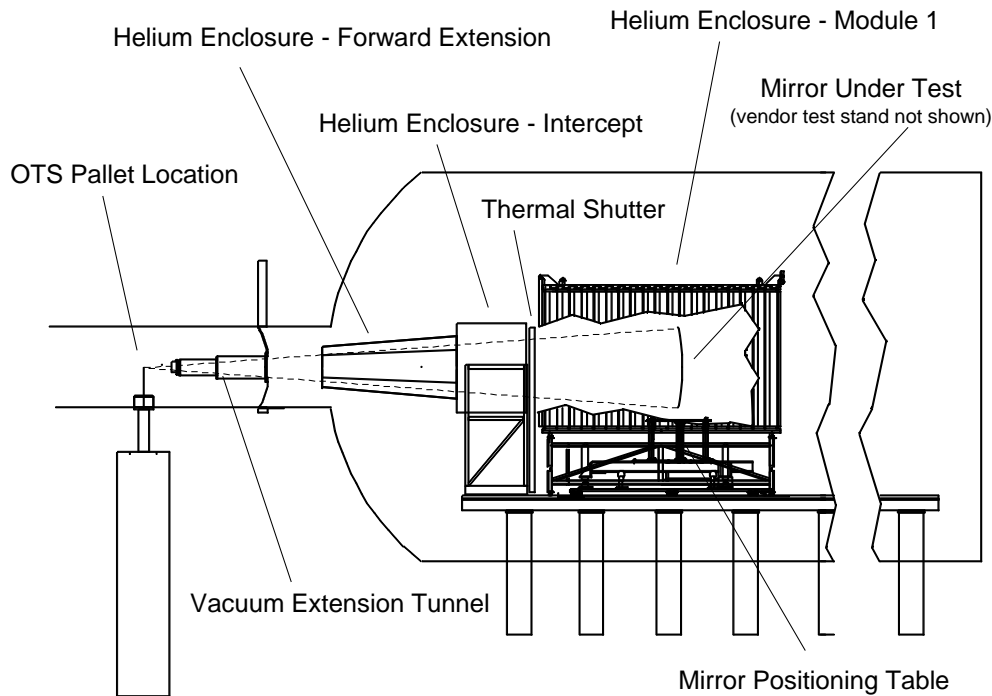
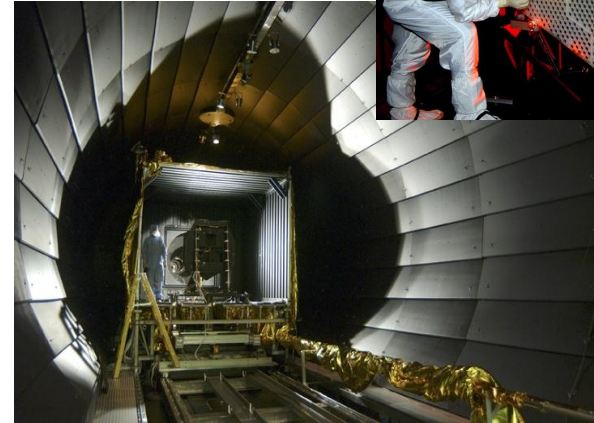
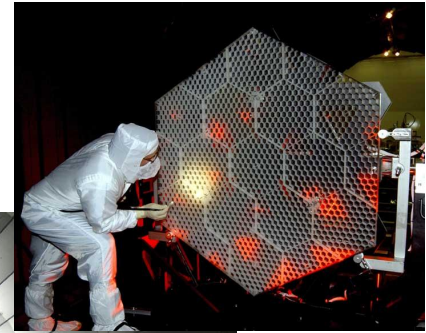



AMDS Figure Change: 30-55K Operational Range

Beryllium

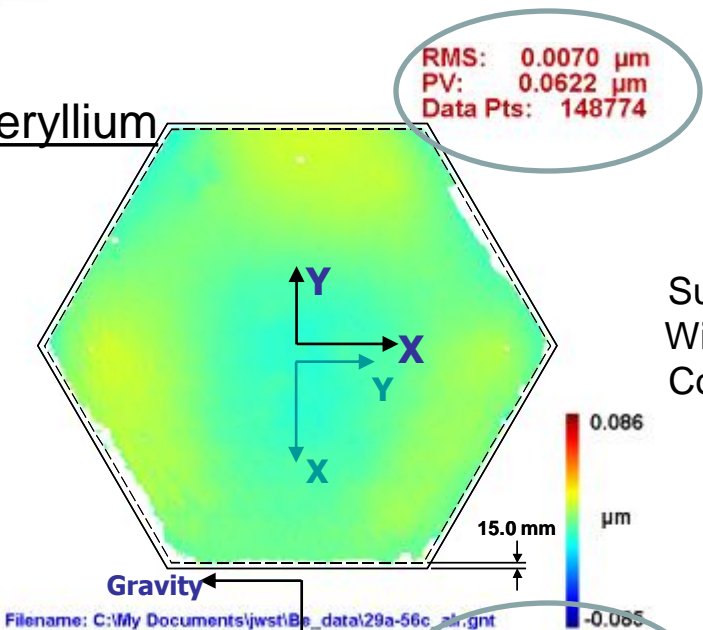

ULE Glass

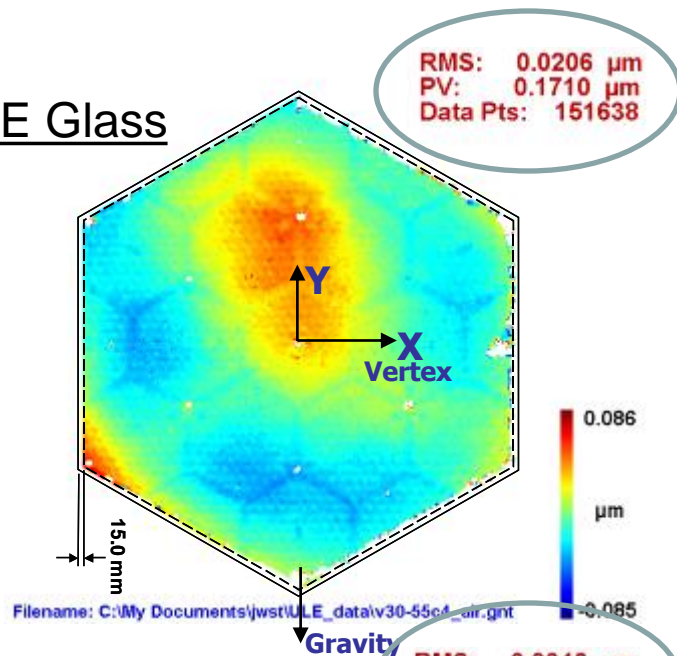

Surface Figure
With Alignment
Compensation

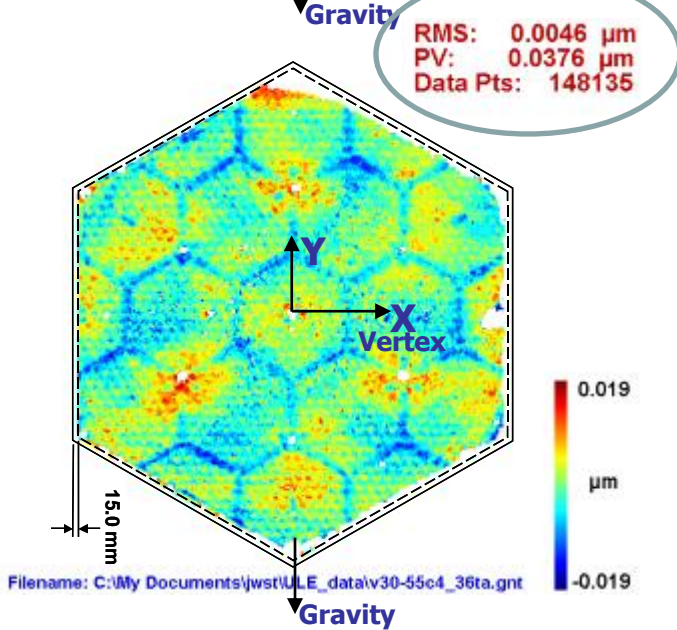
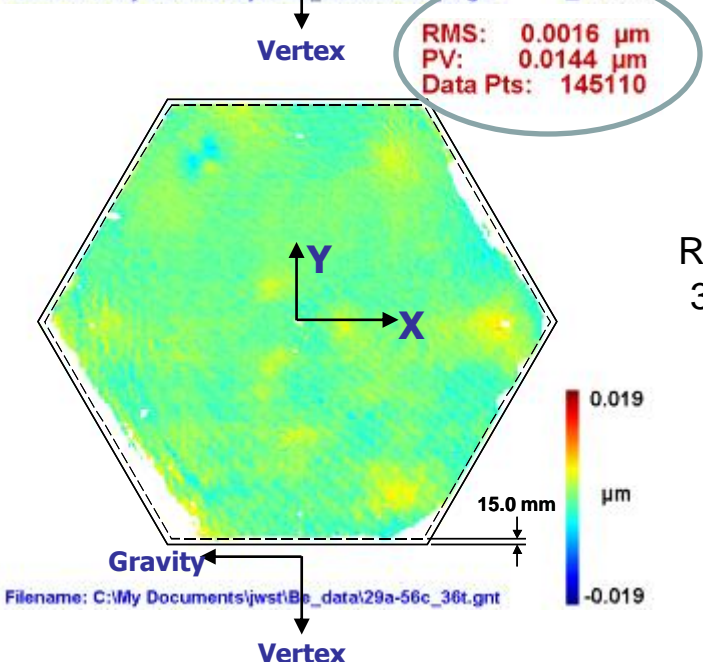

Residual with
36 Zernikes
Removed

James Webb Space Telescope

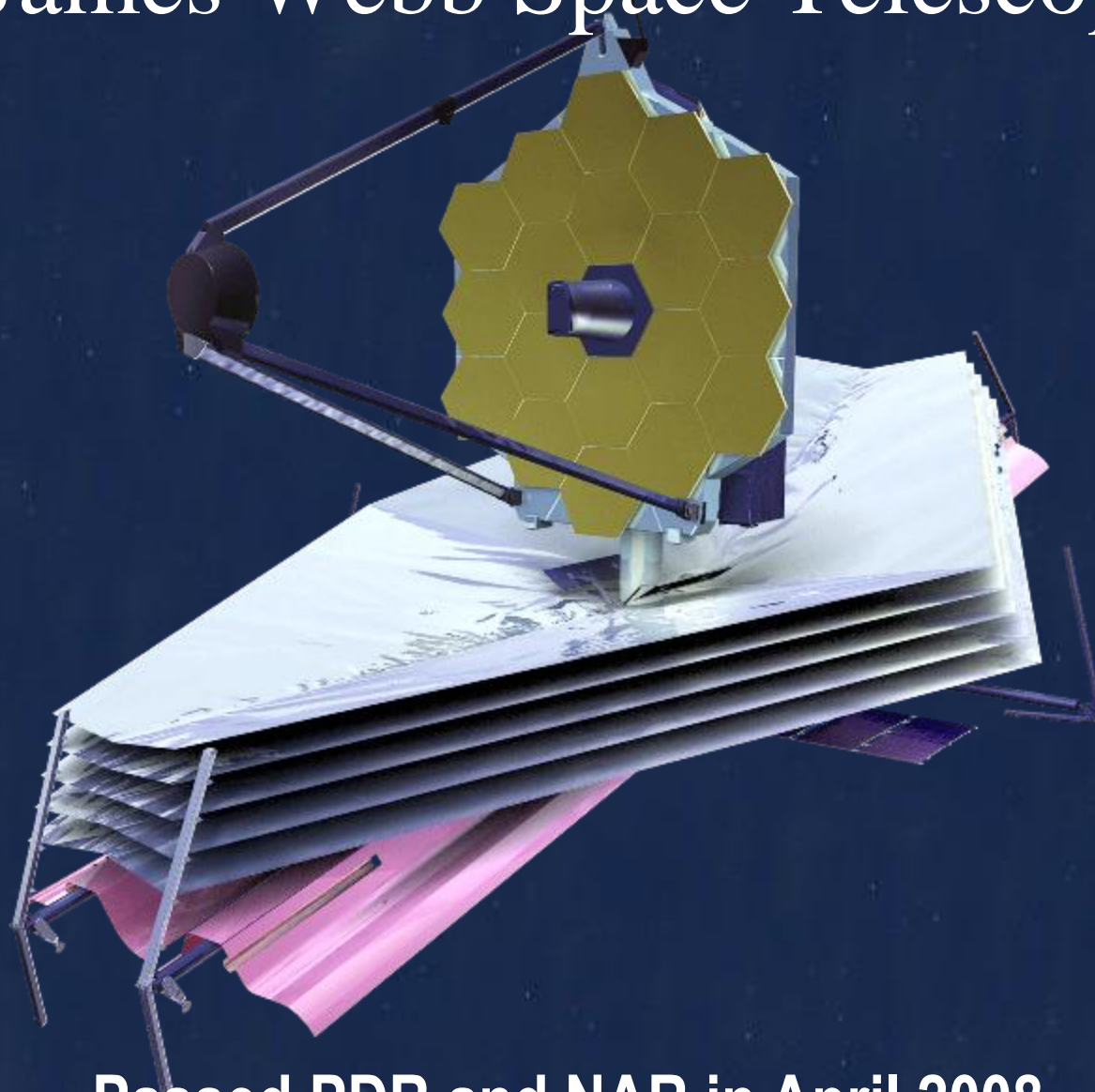

Passed PDR and NAR in April 2008



Mirror Technology Development - 2000

Challenges for Space Telescopes:

Areal Density to enable up-mass for larger telescopes.

Cost & Schedule Reduction.

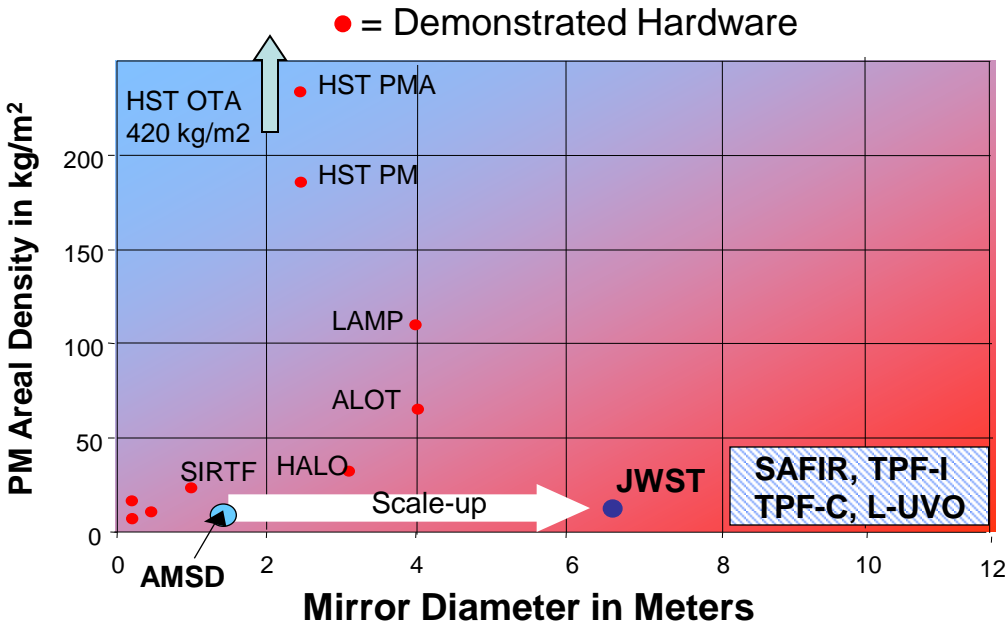
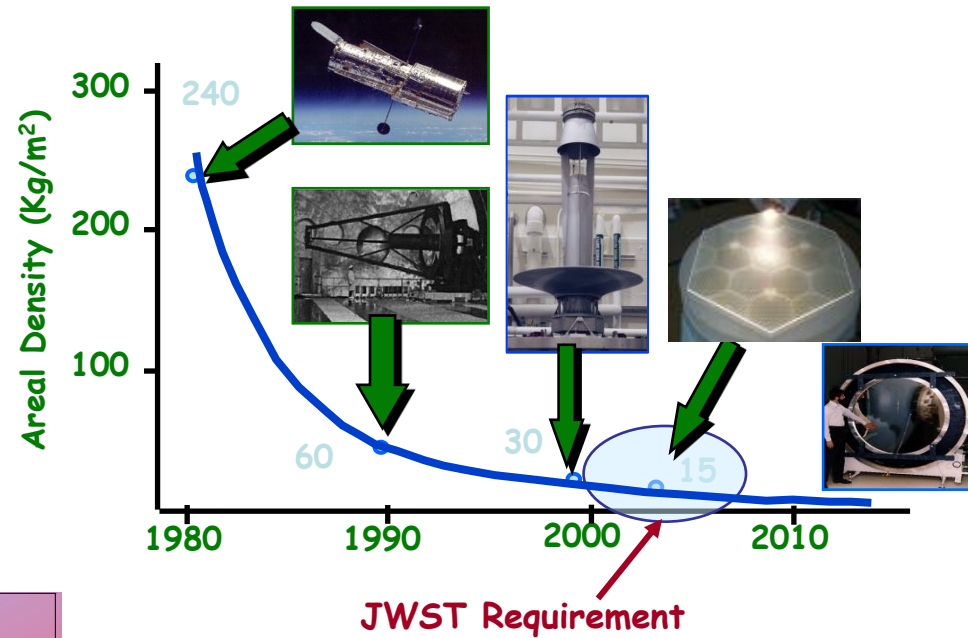

Primary Mirror	Time & Cost	
HST (2.4 m)	≈ 1 m ² /yr	≈ \$10M/m ²
Spitzer (0.9 m)	≈ 0.3 m ² /yr	≈ \$10M/m ²
AMSD (1.2 m)	≈ 0.7 m ² /yr	≈ \$4M/m ²
JWST (8 m)	> 6 m ² /yr	< \$3M/m ²

Note: Areal Cost in FY00 \$



Mirror Technology Development 2010

Lessons Learned

Mirror Stiffness (mass) is required to survive launch loads.

Cost & Schedule Improvements are holding but need another 10X reduction for even larger telescopes

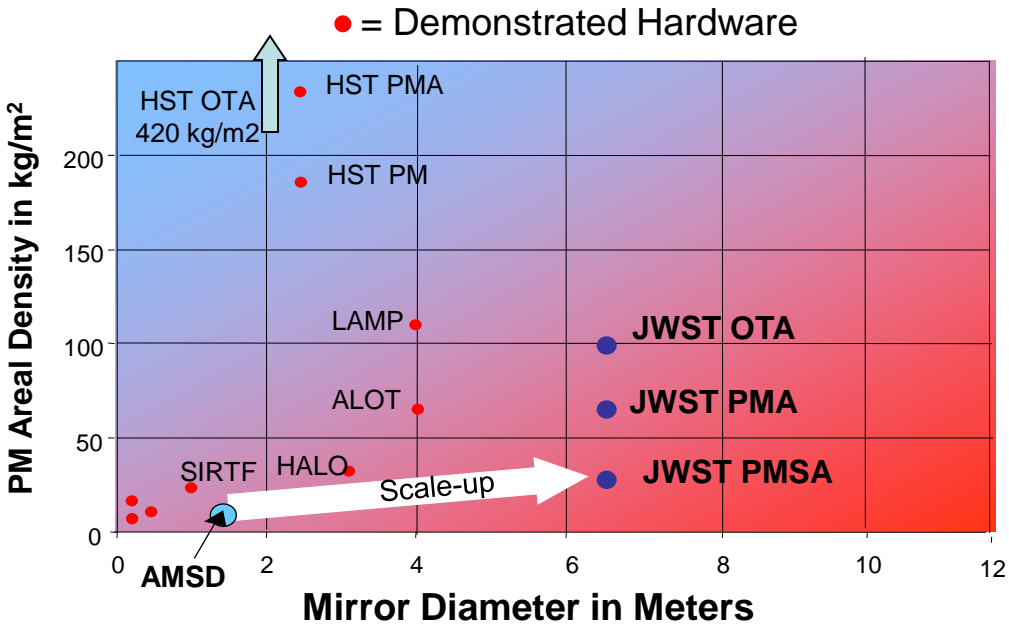
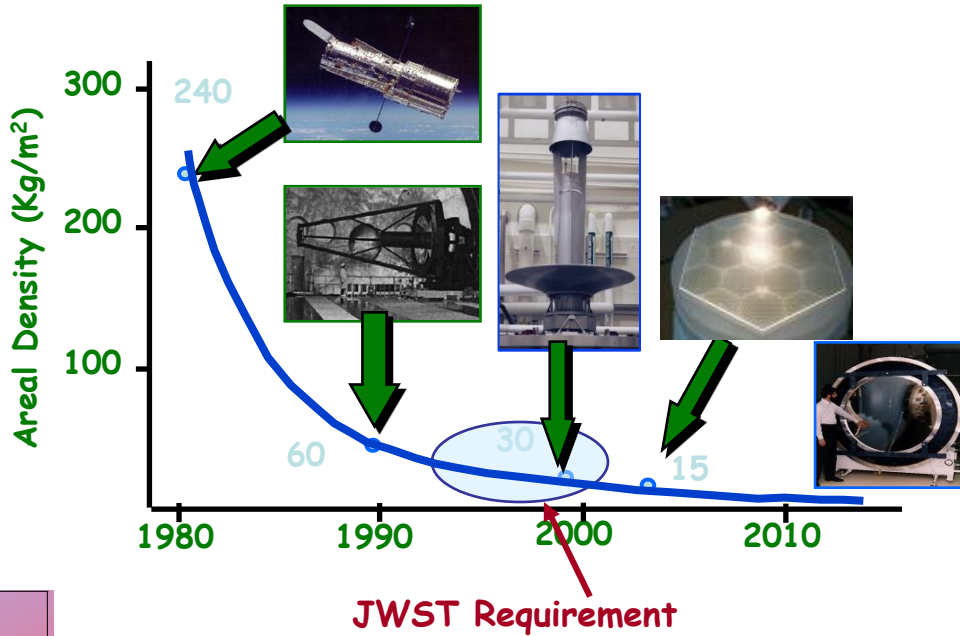

Primary Mirror	Time & Cost	
HST (2.4 m)	≈ 1 m ² /yr	≈ \$12M/m ²
Spitzer (0.9 m)	≈ 0.3 m ² /yr	≈ \$12M/m ²
AMSD (1.2 m)	≈ 0.7 m ² /yr	≈ \$5M/m ²
JWST (6.5 m)	≈ 5 m ² /yr	≈ \$6M/m ²

Note: Areal Cost in FY10 \$

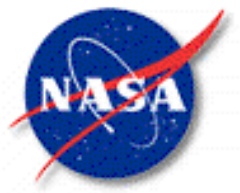

Chickens, Eggs and the Future

**Was Shuttle designed to launch
Great Observatories or were Great
Observatories designed to be
launched by the shuttle?**

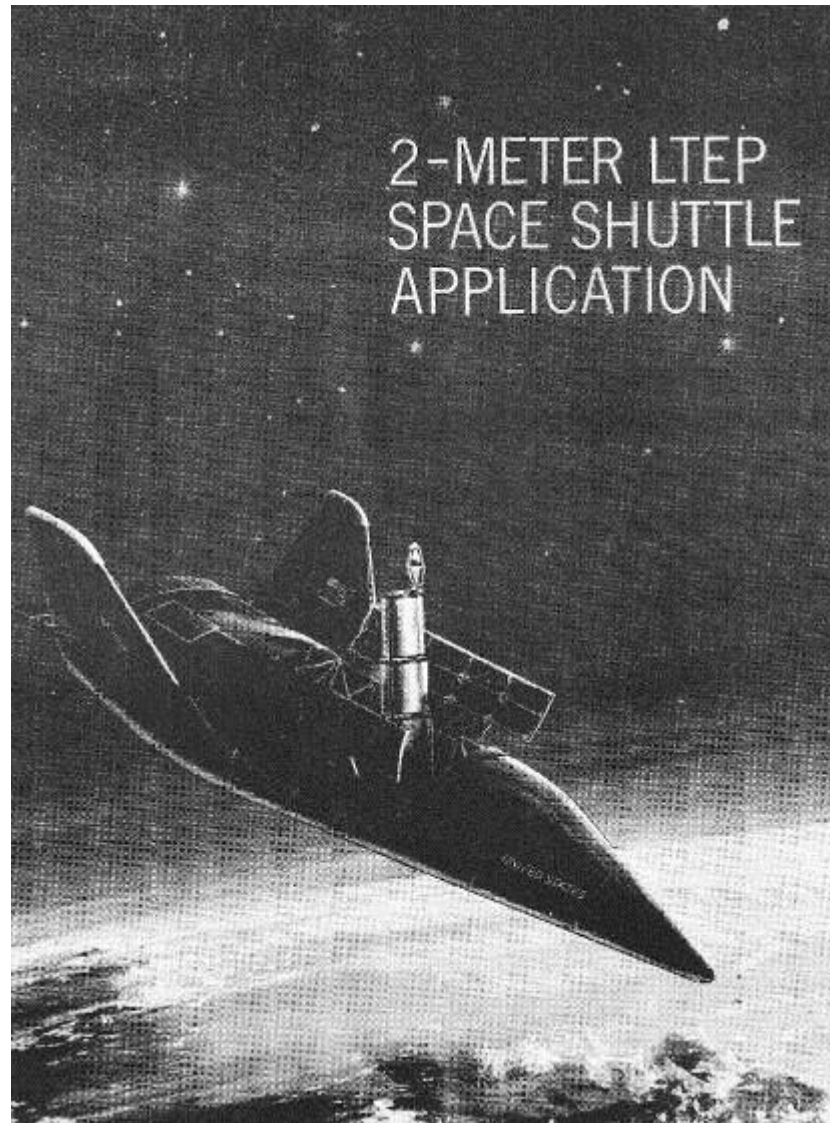
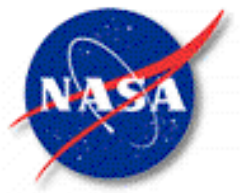

“Large Telescope Experiment Program (LTP) Executive Summary”,
Alan Wissinger, April 1970

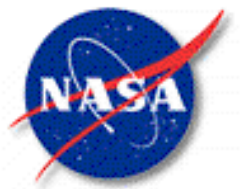

Design Synergy

Shuttle

Payload Bay designed to deploy, retrieve and service spacecraft
Robotic Arm for capturing and repairing satellites.

Mission Spacecraft

Spacecraft designed to be approached, retrieved, and repaired
Generic Shuttle-based carriers to berth and service on-orbit

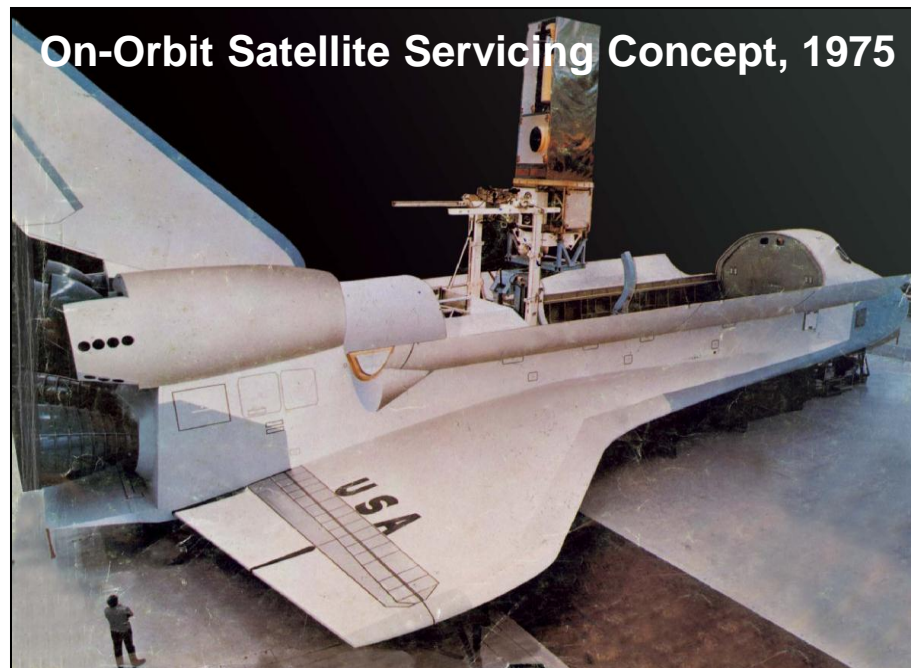

Chandra and Spitzer were originally intended to be serviceable.

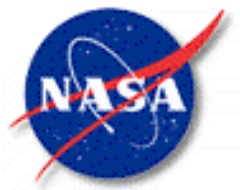

Great Observatories designed for Shuttle

Hubble, Compton and Chandra were specifically designed to match Space Shuttle's payload volume and mass capacities.

	Launch	Payload Mass	Payload Volume
Space Shuttle Capabilities		25,061 kg (max at 185 km) 16,000 kg (max at 590 km)	4.6 m x 18.3 m
Hubble Space Telescope	1990	11,110 kg (at 590 km)	4.3 m x 13.2 m
Compton Gamma Ray Observatory	1991	17,000 kg (at 450 km)	
Chandra X-Ray Telescope (and Inertial Upper Stage)	2000	22,800 kg (at 185 km)	4.3 m x 17.4 m
Spitzer was originally Shuttle IR Telescope Facility (SIRTF)			

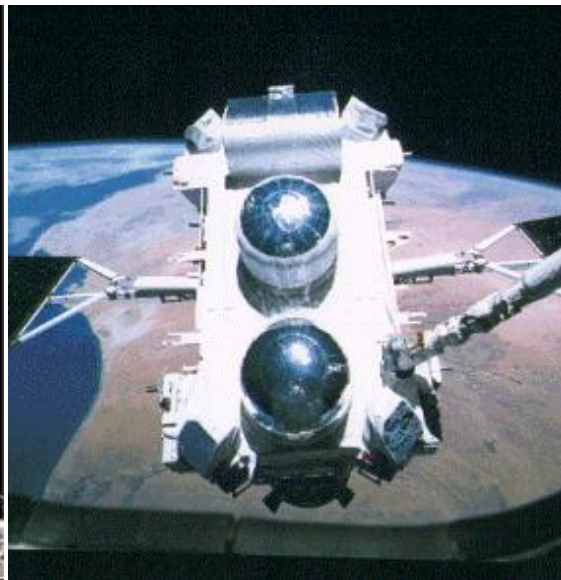



Launch Vehicles Continue to Drive Design

Similarly, JWST is sized to the Capacities of Ariane 5

	Payload Mass	Payload Volume
Ariane 5	6600 kg (at SE L2)	4.5 m x 15.5 m
James Webb Space Telescope	6530 kg (at SE L2)	4.47 m x 10.66 m

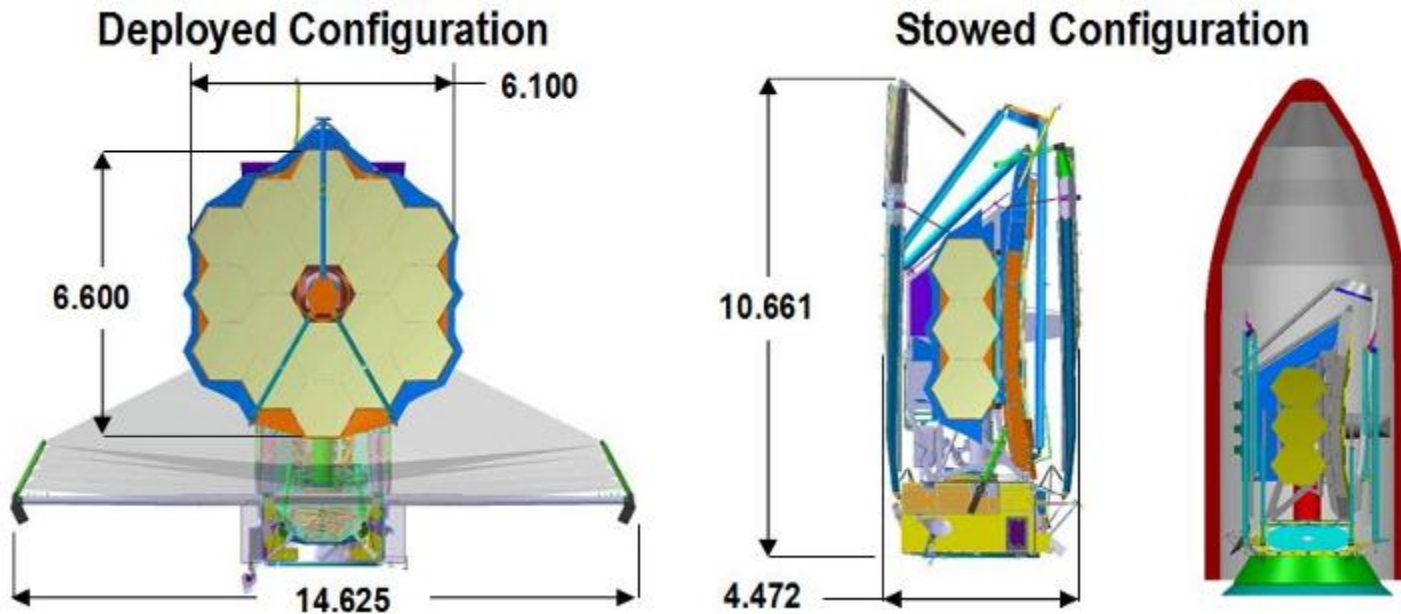



And now the **FUTURE**

**A Heavy Lift Launch Vehicle
would be a Disruptive
Capability which would offers
the potential for completely new
Mission Concepts**





SLS delivers 4X more Mass to Orbit

Sun

Earth

Moon



Hubble in LEO

Current Capabilities can Deliver

23,000 kg to Low Earth Orbit

10,000 kg to GTO or L2TO Orbit

5 meter Shroud

SLS can Deliver

~100,000 kg to Low Earth Orbit

~40,000 kg to L2TO Orbit

8 meter Shroud

L2

1.5 M km from Earth

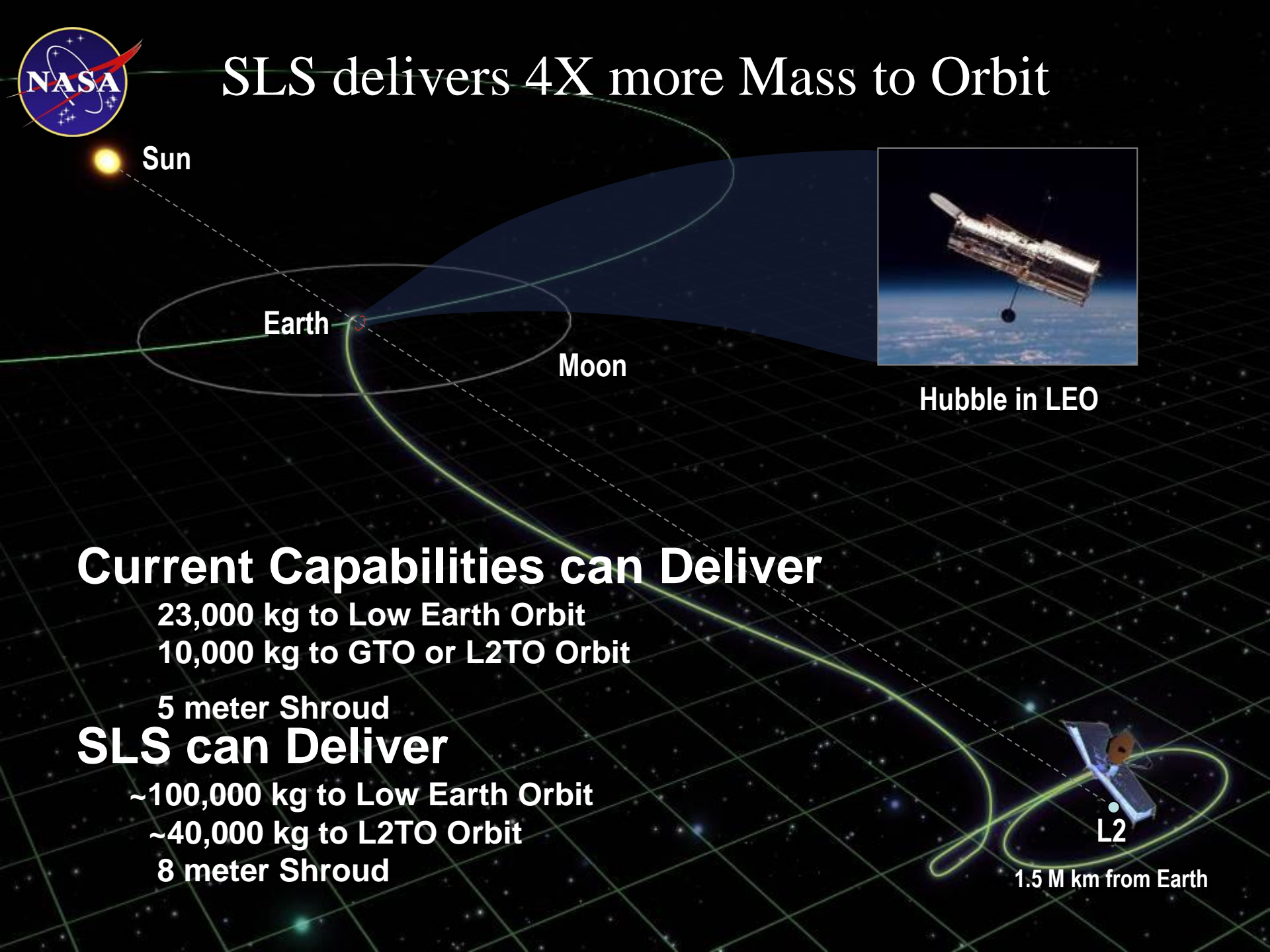



SLS Changes Paradigms

SLS Mass & Volume enable entirely new Mission Architectures:

- 8 meter class Monolithic UV/Visible Observatory

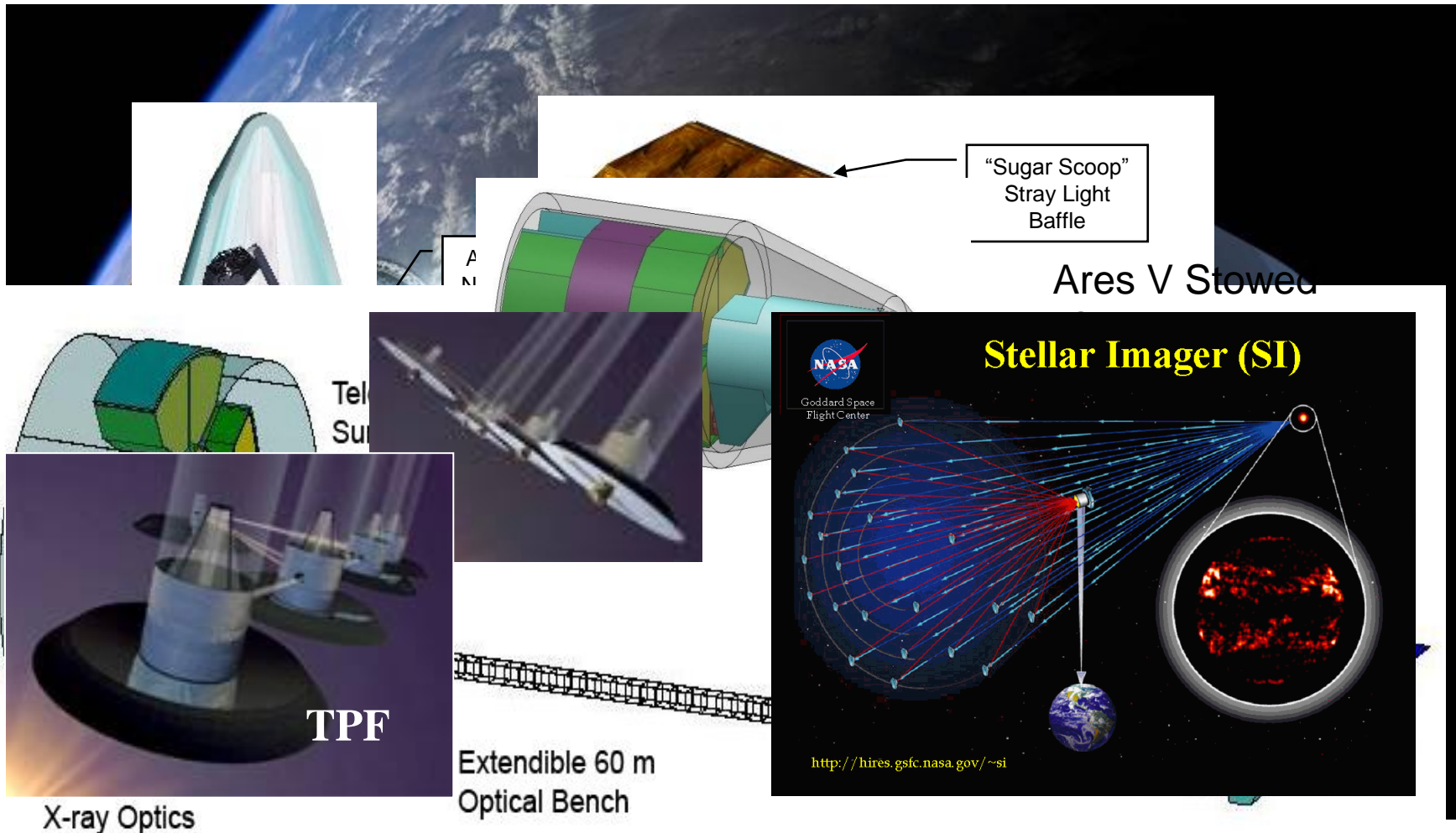

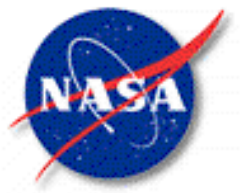

**And now for something
completely different**

**Giant Telescopes
without mirrors**



MOIRE 20 meter Diffractive Telescope

Design Reference Mission Performance Goals

- Persistence – 24/7
- Missile launch detection & vehicle tracking
- Ground Sample Distance -- ~ 1m
- Visible/IR Video @ > 1 Hz
- Field of View > 100 sq km
- Field of Regard – 15,000 km by 15,000 km (without slewing)
- < \$500M/copy (after R&D)

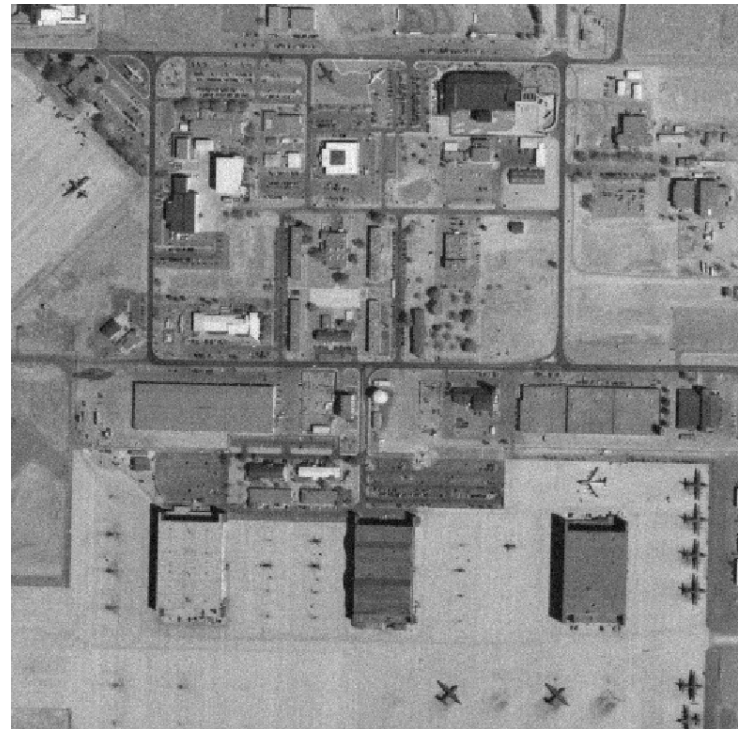
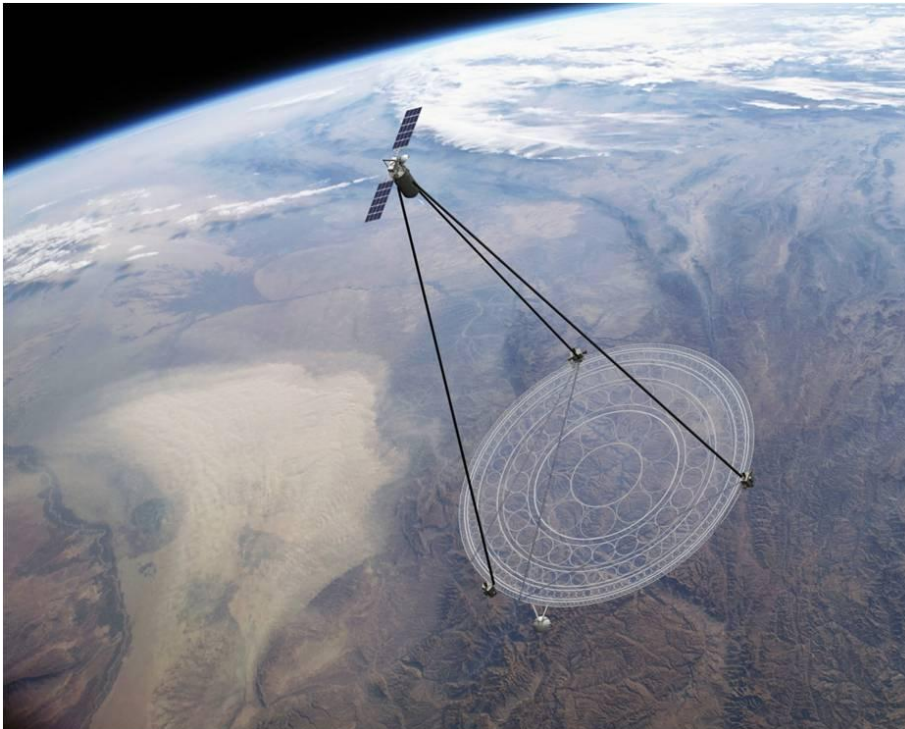



Consider what you could do with Multi-Spectral Fiber Detectors

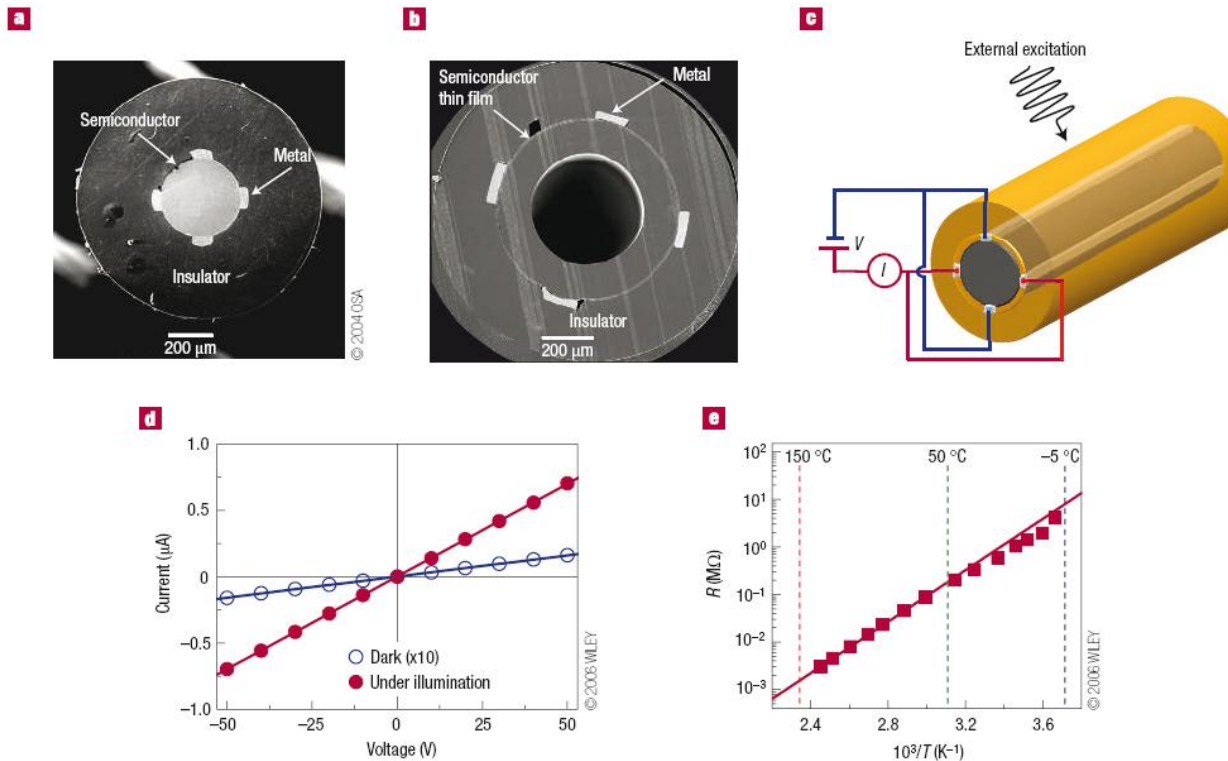

Figure 3 Metal–semiconductor–insulator fibre devices. **a**, SEM micrograph of a cross-section (the semiconductor is $\text{As}_{30}\text{Se}_{50}\text{Te}_{10}\text{Sn}_5$, the insulator polymer is PES, and the metal is Sn). Image reprinted from ref. 26. **b**, SEM micrograph of a thin-film fibre device (the semiconductor is As_2Se_3 , the insulator polymer is PES, and the metal is Sn). **c**, Electrical connection of the four metal electrodes at the periphery of the fibre to an external electrical circuit. **d**, The current–voltage characteristic curve of a photosensitive solid-core fibre device (980 μm outer diameter, 15 cm long). The conductivity increases upon illumination (20 mW, white light) when compared with dark conditions. **e**, The resistance of a thermally sensitive solid-core fibre device (1,150 μm outer diameter, 9 cm long) as a function of temperature. **c–e** reprinted with permission from ref. 28.

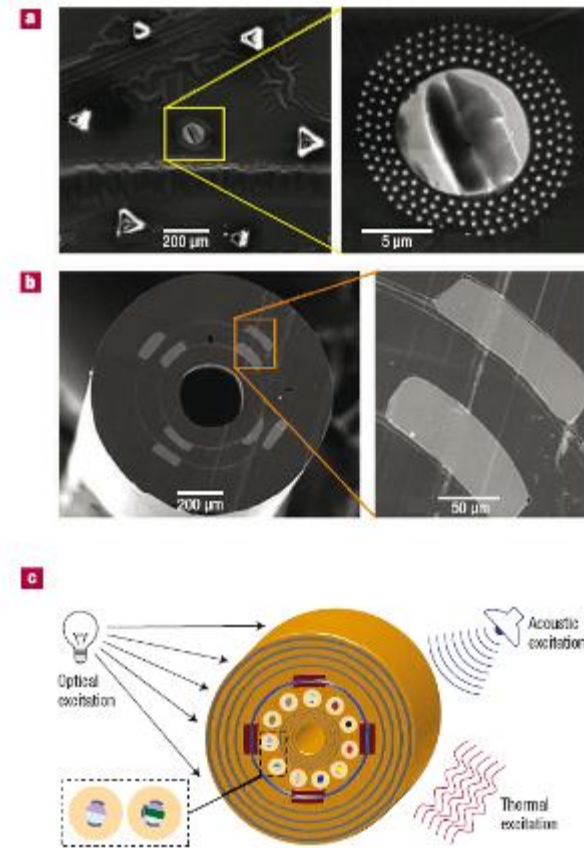

Figure 8 Fibre-device integrated bundles produced by stacking and redrawing. **a**, An array of chalcogenide-glass nanowires surrounding a solid-core of highly nonlinear chalcogenide glass. **b**, Two concentric thin-semiconductor-film devices integrated into the same fibre. **c**, Future vision of integrated fibre-device bundles. A single fibre consists of a hollow core lined with an omnidirectional reflector for optical-power transmission. The fibre is surrounded with another omnidirectional reflector, which may contain multiple cavities, for spectral filtering of externally incident radiation. The fibre contains thin-film semiconducting devices, and also multiple devices distributed over the cross-section, with each device sensitive to a different environmental parameter (light, heat, acoustic waves and so on). Logical operations may also be implemented with simple semiconductor junctions, two of which are shown in the inset.

Abouraddy, et al., “Towards multimaterial multifunctional fibres that see, hear, sense and communicate”, *Nature Materials*, Vol 6, pp.336, May 2007.



Computed Axial Tomography Astronomy (Astro-CAT)

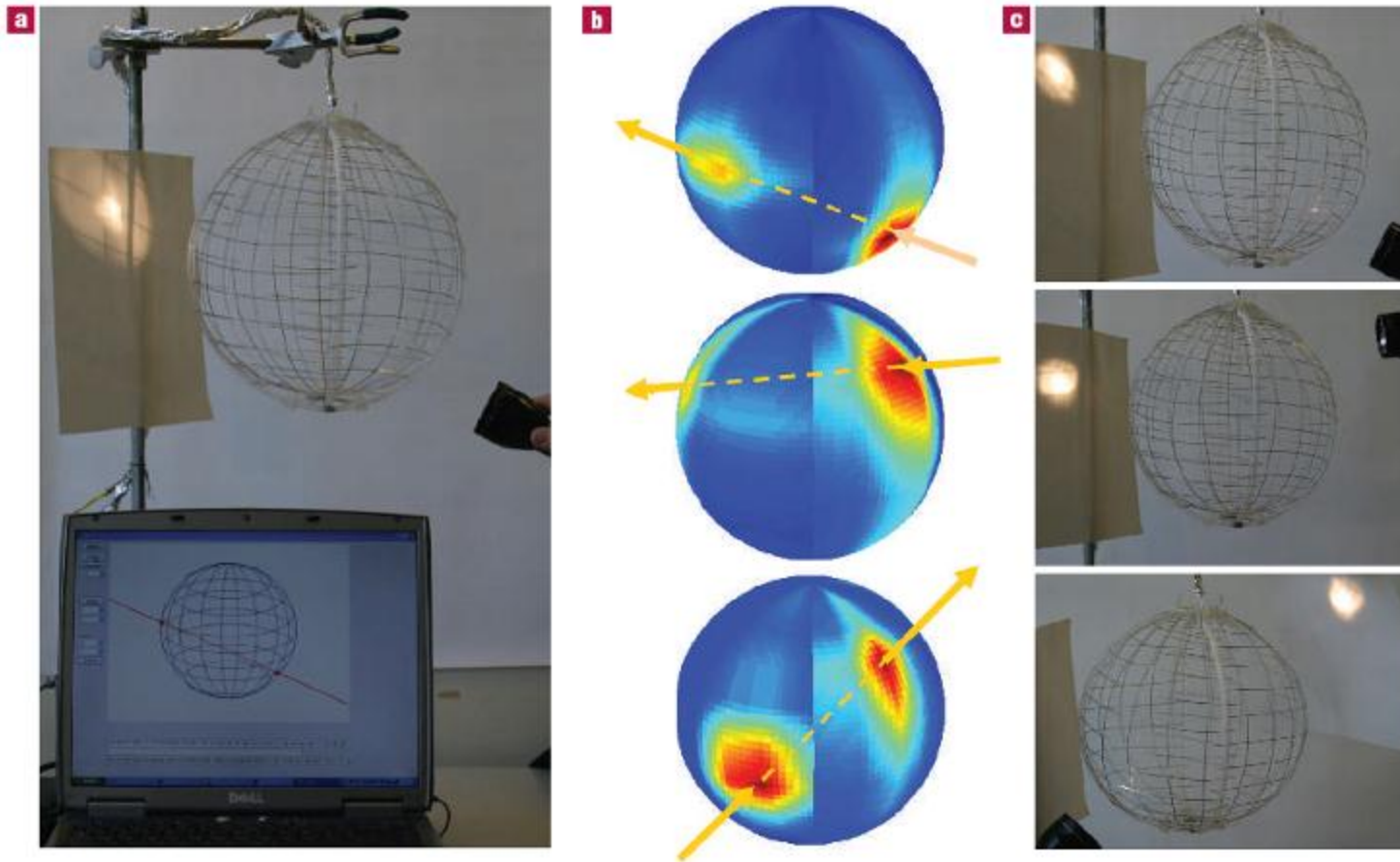
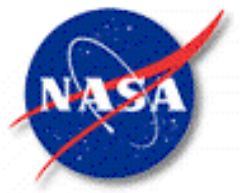

Figure 2 Omnidirectional light detection. a, A closed spherical fibre web is an omnidirectional photodetector which detects the direction of the beam throughout a solid angle of 4π . The spherical web is sufficiently transparent to see through and for a beam of light to traverse unimpeded. b, The distribution of the electrical signals detected by the fibres for a light beam incident in three different directions. The arrows indicate the direction of the beams, and the dashed portion of each arrow corresponds to the beam's path inside the sphere. c, Photographs of the three beam trajectories that resulted in the signal distributions shown in b.

Abouraddy, et al., “Large-scale optical-field measurements with geometric fibre constructs”, *Nature Materials*, Vol 5, pp.532, July 2006.



Any Question?

