

High-temperature sensors have been used in silicon carbide electronic oscillator circuits. The frequency of the oscillator changes as a function of the changes in the sensed parameter, such as pressure. This change is analogous to changes in the pitch of a person's voice.

The output of this oscillator and many others may be superimposed onto a single medium. This medium may be the power lines supplying current to the sensors, a third wire dedicated to data transmission, the airwaves through radio transmission, an optical medium, etc. However, with nothing to distin-

guish the identities of each source — that is, the source separation — this system is useless.

Using digital electronic functions, unique codes or patterns are created and used to modulate the output of the sensor. By using a dividend of the oscillator frequency to generate the code, a constant a priori number of oscillator cycles will define each bit. At the receiver, a detected frequency will be correlated with stored code patterns to find a match. If detected and verified as coming from a known sender, a frequency will be disassociated from noise and

from other transmitting sensors in that it has a unique modulation pattern or "voice." The length of the detected code, or instantaneously, the frequency detected, is the measure, and intelligent data transfer has been accomplished.

*This work was done by Michael Krasowski of Glenn Research Center. Further information is contained in a TSP (see page 1).*

*Inquiries concerning rights for the commercial use of this invention should be addressed to NASA Glenn Research Center, Innovative Partnerships Office, Attn: Steven Fedor, Mail Stop 4-8, 21000 Brookpark Road, Cleveland, Ohio 44135. Refer to LEW-18910-1.*

---

## Using Combustion Synthesis to Reinforce Berms and Other Regolith Structures

**New structures will require a minimum of maintenance and upkeep.**

*Lyndon B. Johnson Space Center, Houston, Texas*

The Moonraker Excavator and other tools under development for use on the Moon, Mars, and asteroids will be employed to construct a number of civil engineering projects and to mine the soil. Mounds of loose soil will be subject to the local transport mechanisms plus artificial mechanisms such as blast effects from landers and erosion from surface vehicles. Some of these structures will require some permanence, with a minimum of maintenance and upkeep.

Combustion Synthesis (CS) is a family of processes and techniques whereby chemistry is used to transform materials, often creating flame in a hard vacuum. CS can be used to stabilize civil engineering works such as berms, habitat shielding, ramps, pads, roadways, and the like. The method is to unroll thin sheets of CS fabric between layers of regolith and then fire the fabric, creating a

continuous sheet of crusty material to be interposed among layers of loose regolith. The combination of low-energy processes, ISRU (in situ resource utilization) excavator, and CS fabrics, seems compelling as a general method for establishing structures of some permanence and utility, especially in the role of robotic missions as precursors to manned exploration and settlement.

In robotic precursory missions, excavator/mobility ensembles mine the Lunar surface, erect constructions of soil, and dispense sheets of CS fabrics that are covered with layers of soil, fired, and then again covered with layers of soil, iterating until the desired dimensions and forms are achieved. At the base of each berm, for example, is a shallow trench lined with CS fabric, fired and filled, mounded, and then covered and fired, iteratively to provide a footing against lateral shear. A larger

trench is host to a habitat module, back-filled, covered with fabric, covered with soil, and fired.

Covering the applied CS fabric with layers of soil before firing allows the resulting matrix to incorporate soil both above and below the fabric ply into the fused layer, developing a very irregular surface which, like sandpaper, can provide an anchor for loose soil. CS fabrics employ a coarse fiberglass weave that persists as reinforcement for the fired material. The fiberglass softens at a temperature that exceeds the combustion temperature by factors of two to three, and withstands the installation process.

This type of structure should be more resistant to rocket blast effects from Lunar landers.

*This work was done by Gary Rodriguez of sysRAND Corporation for Johnson Space Center. Further information is contained in a TSP (see page 1). MSC-24411-1*

---

## Visible-Infrared Hyperspectral Image Projector

*Goddard Space Flight Center, Greenbelt, Maryland*

The VisIR HIP generates spatially-spectrally complex scenes. The generated scenes simulate real-world targets viewed by various remote sensing instruments. The VisIR HIP consists of two subsystems: a spectral engine and a spa-

tial engine. The spectral engine generates spectrally complex uniform illumination that spans the wavelength range between 380 nm and 1,600 nm. The spatial engine generates two-dimensional gray-scale scenes. When combined, the

two engines are capable of producing two-dimensional scenes with a unique spectrum at each pixel. The VisIR HIP can be used to calibrate any spectrally sensitive remote-sensing instrument. Tests were conducted on the Wide-field

Imaging Interferometer Testbed at NASA's Goddard Space Flight Center.

The device is a variation of the calibrated hyperspectral image projector developed by the National Institute of Standards and Technology in Gaithersburg, MD. It uses Gooch & Housego Visible and Infrared OL490 Agile Light

Sources to generate arbitrary spectra. The two light sources are coupled to a digital light processing (DLP™) digital mirror device (DMD) that serves as the spatial engine. Scenes are displayed on the DMD synchronously with desired spectrum. Scene/spectrum combinations are displayed in rapid succession,

over time intervals that are short compared to the integration time of the system under test.

*This work was done by Matthew Bolcar of Goddard Space Flight Center. Further information is contained in a TSP (see page 1). GSC-16422-1*

## Three-Axis Attitude Estimation With a High-Bandwidth Angular Rate Sensor

Commercial applications include pointing of cameras on space telescopes, spacecraft instrument payloads, moving vehicles, and surveillance from airborne platforms.

NASA's Jet Propulsion Laboratory, Pasadena, California

A continuing challenge for modern instrument pointing control systems is to meet the increasingly stringent pointing performance requirements imposed by emerging advanced scientific, defense, and civilian payloads. Instruments such as adaptive optics telescopes, space interferometers, and optical communications make unprecedented demands on precision pointing capabilities. A cost-effective method was developed for increasing the pointing performance for this class of NASA applications.

The solution was to develop an attitude estimator that fuses star tracker and gyro measurements with a high-bandwidth angular rotation sensor (ARS). An ARS is a rate sensor whose bandwidth extends well beyond that of the gyro, typically up to 1,000 Hz or higher. The most promising ARS sensor technology is based on a magnetohydrodynamic concept, and has recently become available commercially. The key idea is that the sensor fusion of the star tracker, gyro, and ARS provides a high-bandwidth attitude estimate suitable for supporting pointing control with a fast-steering mirror or other type of tip/tilt correction for increased performance. The ARS is relatively inexpensive and can be bolted directly next to the gyro and star tracker on the spacecraft bus.

The high-bandwidth attitude estimator fuses an ARS sensor with a standard three-axis suite comprised of a gyro and star tracker. The estimation architecture is based on a dual-complementary filter (DCF) structure. The DCF takes a frequency-weighted combination of the sensors such that each sensor is most heavily weighted in a frequency region where it has the lowest noise.

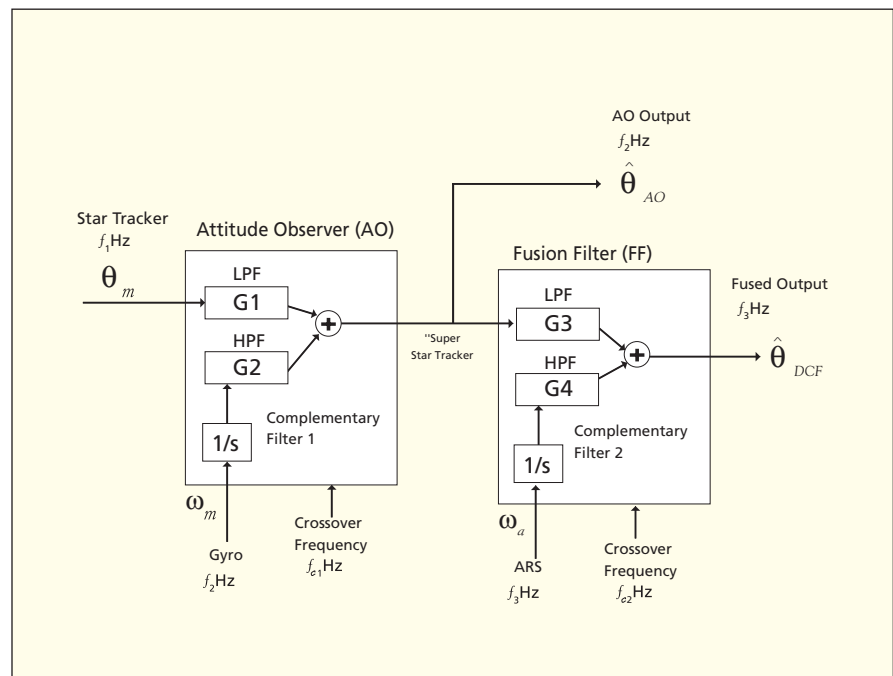

**Dual Complementary Filter (DCF) architecture blends ARS with star tracker and gyro measurements to produce an accurate high-bandwidth attitude estimate. (Note: LPF and HPF are low-pass and high-pass filters, respectively.)**

An important property of the DCF is that it avoids the need to model disturbance torques in the filter mechanization. This is important because the disturbance torques are generally not known in applications. This property represents an advantage over the prior art because it overcomes a weakness of the Kalman filter that arises when fusing more than one rate measurement.

An additional advantage over prior art is that, computationally, the DCF requires significantly fewer real-time calculations than a Kalman filter formulation. There are essentially two reasons

for this: the DCF state is not augmented with angular rate, and measurement updates occur at the slower gyro rate instead of the faster ARS sampling rate.

Finally, the DCF has a simple and compelling architecture. The DCF is exactly equivalent to flying two identical attitude observers, one at low rate and one at high rate. These attitude observers are exactly of the form currently flown on typical three-axis spacecraft.

*This work was done by David S. Bayard and Joseph J. Green of Caltech for NASA's Jet Propulsion Laboratory. Further information is contained in a TSP (see page 1). NPO-48171*