

STRATEGIES FOR VALIDATION TESTING OF GROUND SYSTEMS

Tammy L. Annis
Timothy R. Honeycutt
Integrated Test & Verification
Ground Operations Project, Constellation Program
NASA, Kennedy Space Center

ABSTRACT

In order to accomplish the full Vision for Space Exploration announced by former President George W. Bush in 2004, NASA will have to develop a new space transportation system and supporting infrastructure. The main portion of this supporting infrastructure will reside at the Kennedy Space Center (KSC) in Florida and will either be newly developed or a modification of existing vehicle processing and launch facilities, including Ground Support Equipment (GSE). This type of large-scale launch site development is unprecedented since the time of the Apollo Program. In order to accomplish this successfully within the limited budget and schedule constraints a combination of traditional and innovative strategies for Verification and Validation (V&V) have been developed. The core of these strategies consists of a building-block approach to V&V, starting with component V&V and ending with a comprehensive end-to-end validation test of the complete launch site, called a Ground Element Integration Test (GEIT). This paper will outline these strategies and provide the high level planning for meeting the challenges of implementing V&V on a large-scale development program.

KEY WORDS: Systems, Elements, Subsystem, Integration Test, Ground Systems, Ground Support Equipment, Component, End Item, Test and Verification Requirements (TVR), Verification Requirements (VR)

INTRODUCTION

The Constellation Program (CxP) is responsible for planning and implementing those programs necessary to satisfy the requirements of national space exploration policies as delegated by the NASA Administrator. At the core of NASA's future space exploration is the return to the moon, where NASA will build a sustainable long term human presence. As the space shuttle approaches retirement and the international Space Station nears completion, Constellation is building the next fleet of vehicles to take astronauts back to the moon. The fleet of vehicles will be launched at Kennedy Space Center (KSC) using Ground Systems.

KSC Ground Operations Project is responsible for developing the launch site ground infrastructure to meet the Constellation mission. This infrastructure consists of the newly developed or modified physical support equipment, systems and facilities that are required to perform services at the launch, landing, and retrieval sites in support of the Constellation missions. Functions provided by the Ground Systems include receipt and inspection of flight hardware elements, software, cargo integration/deintegration; ground support equipment; spacecraft, launch vehicle; off-line processing of cargo; spacecraft and launch vehicle integration; integrated testing; reusable flight hardware refurbishment, launch; recovery; search and rescue; logistics; and command, control and communications in support of ground processing.

This type of large-scale launch site development is unprecedented since the time of the Apollo Program. In order to accomplish this successfully within the limited budget and schedule constraints a combination of traditional and innovative strategies for Verification and Validation (V&V) have been developed. The core of these strategies consists of a building-block approach to V&V, starting with component V&V and ending with a comprehensive end-to-end validation test of the complete launch site, called a Ground Element Integration Test (GEIT). The GEIT will be led by the operations organization and supported by the design organization. This validation test consists of exercising people, processes and procedures using simulators and emulators in place of the launch vehicle to perform final validation of Ground Systems prior to the traditional time of performing this test. The traditional time would occur after the hardware has been turned over from the design organization to the operations organization.



Figure 1, Kennedy Space Center – Geographical Layout of Major Constellation Facilities

Figure 2, Ground Systems Architecture

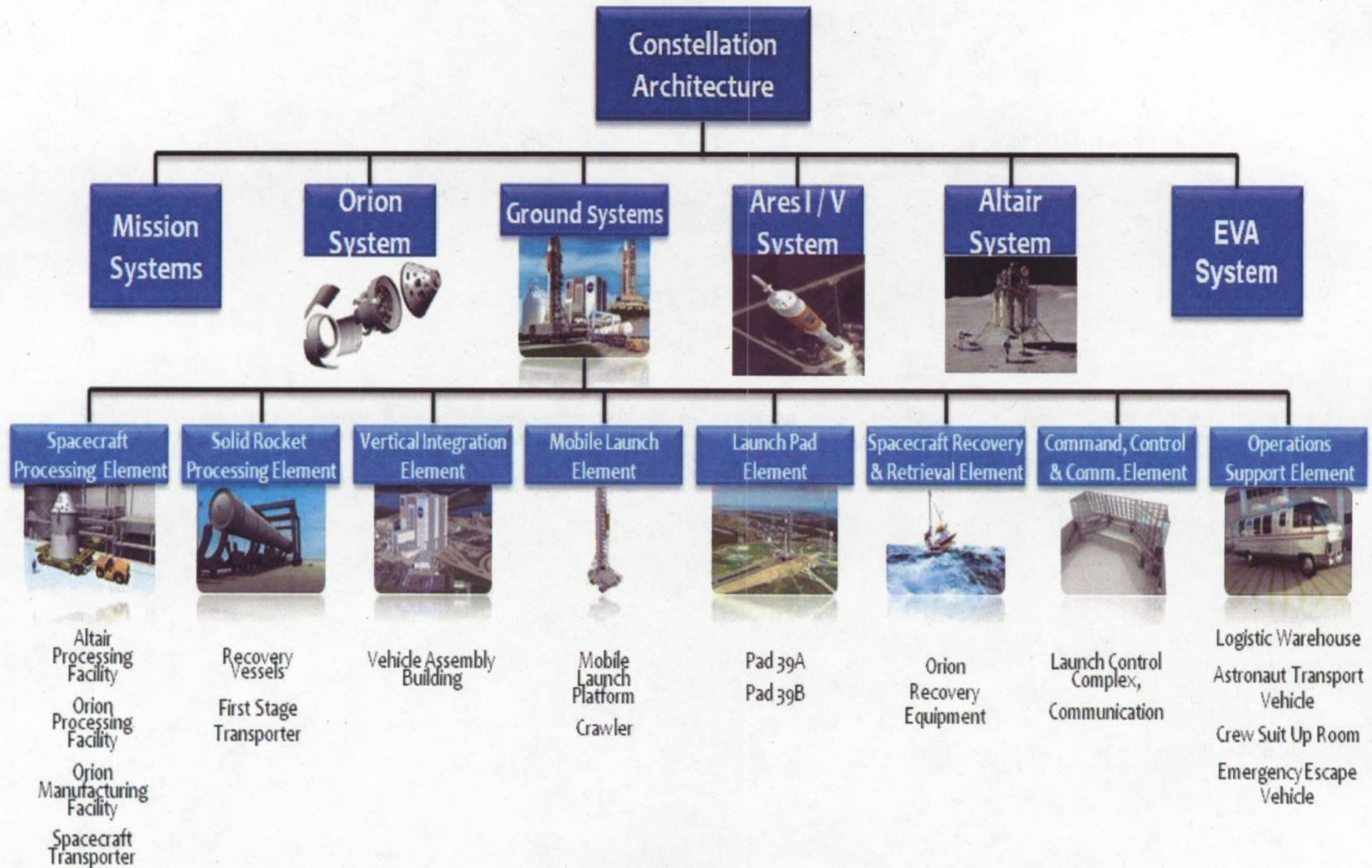

Ground Systems Architecture

The Ground Systems architecture is composed of eight elements as shown in Figure 2. Each element in the architecture represents an asset or group of assets that provide functionality for the ground systems. Each of the elements includes facilities, infrastructure, facility systems, subsystems and support equipment hardware and software required to perform KSC ground operations for the purpose of receiving, processing, integrating, testing, servicing, launching, recovering, de-servicing and de-integrating CxP flight systems.

KSC Engineering provides the element/subsystems with technical and systems expertise for understanding and implementing the requirements that have been allocated to them by the Ground Operations Project (GOP) System Requirements Document (SRD). The Element Requirements Document (ERD) decomposes these requirements down and allocates them to the subsystem level. The engineering organization will use these requirements to develop the necessary ground subsystems for the GOP in support of the Constellation Program.

Requirement Closed Loop Process

The requirements architecture is a closed loop process. The architecture begins with the program requirements and verification requirements and the decomposition of the requirements from the program down to the system. Next, the system decomposes these requirements down to the element and then decomposes these down to the subsystem. Finally, the requirements are then closed from the subsystem back up to the program creating a closed loop process.

A relational database will be utilized to capture and integrate all of the design requirements for the Program and the Projects. Each requirement will have a corresponding verification requirement, which will define how the requirement will be verified. The Verification Requirement (VR) will include a verification method (test, demonstration, analysis or inspection) and a high level description of the verification and the associated success criteria. Each method of a VR will have a Test and Verification Requirement (TVR) to describe in detail how the requirement will be verified. These 3 "items" (requirements, VRs and TVRs) will be logically "linked" in the database to provide a traceable map of how all of the requirements will be satisfied. The results of each verification activity are the basis of closure for each requirement.

Planning of Verification and Validation

During development of Ground Systems, V&V plans are prepared to guide V&V implementation planning i.e., where, when and how will we accomplish V&V events and/or close the requirements. The strategy for verifying and validating this large-scale development project is contained in V&V plans. Currently there are over 12,000 verifications identified. These plans are critical to the success of completing the verifications as well as integrating the V&V activities to occur in parallel. V&V requires a teaming arrangement between designers/developers and operators. V&V traditionally occurred in serial, however for efficiency the new innovative approach now occurs in parallel, which further emphasizes the need for

strong teamwork between these two entities. Therefore, the VRs/TVRs will typically be performed and satisfied by both the design and development and operations engineering communities together as a team. This teaming arrangement will assist in validation activities occurring earlier with allowable risk.

The V&V plans layout the strategy for integrating required hardware/software from other projects, hardware/software from vendors, newly designed hardware/software and heritage equipment into an element and perform each V&V activity as identified by the VRs and TVRs.

Ground Subsystems V&V plans

- a. Provides the planning for subsystem requirements satisfaction by verification of the design
- b. Provides the planning for validation of the subsystems to show that each subsystem operates in its intended operational environment to the satisfaction of the user organization

Design engineering will design, fabricate, assemble and integrate the hardware and software that make up a subsystem. Each subsystem will then be verified with the appropriate verification method(s) (test, demonstration, analysis and/or inspection). The verification of each subsystem will be complete once the design, functional and interface requirements have been met. The subsystems V&V plans define the development test and evaluation verification activities that ensure the subsystem meets its design and performance requirements and the operational test and evaluation validation process that ensures operational requirements are met.

Ground Elements V&V plans

- a. Provides the planning for V&V of facilities, facility systems, and GSE for ground processing of the flight vehicle. Includes planning for system and element requirements satisfaction. Also includes Statement of Work and Heritage Hardware planning. Includes narrative descriptions of V&V tests/demonstrations

Once all of the subsystems within an element have been verified, all of these subsystems (facility infrastructure, facility systems and support equipment) will be integrated together and verified as an element. This verification will consist of ensuring that all subsystems within the element properly operate/function together. The element-to-element interface requirements will be verified using both sides of the interface. The verification of each element will be complete once the functional, interface, and design requirements have been met for that element. The ground element V&V plans define development test and evaluation verification activities that ensure ground elements meet its design and performance requirements. The plans also define the operational test and evaluation validation process that ensures operational requirements are met from the end item level through the development of ground elements level including software, GSE and facility infrastructure.

Ground System

After each of the ground elements has been verified, a Ground Element Integration Test (GEIT) or set of tests will be performed. These testing activities will consist of operating the ground elements in concert with one another in order to confirm the interoperability and functionality between the elements. Once Ground Systems validation (GEIT) is complete, Ground Systems will be ready to interface with flight hardware.

Ground Element Integration Test Details

GEIT is an integration test between multiple GOP ground elements in order to validate Ground Systems prior to processing the first flight test vehicle. GEIT will consist of operating the ground elements in concert with one another in order to confirm the interoperability and functionality between the ground elements. These tests will occur after the ground systems have been verified. These tests are used to assure that the ground elements can work together as a unified ground system and support flight processing and launch operations. Refer to Figure 3 for the diagram showing the integrated interfaces of elements and their subsystems. Note: Simulators and emulators will be used in place of the vehicle for actual testing.

CCCE Integrated Diagram

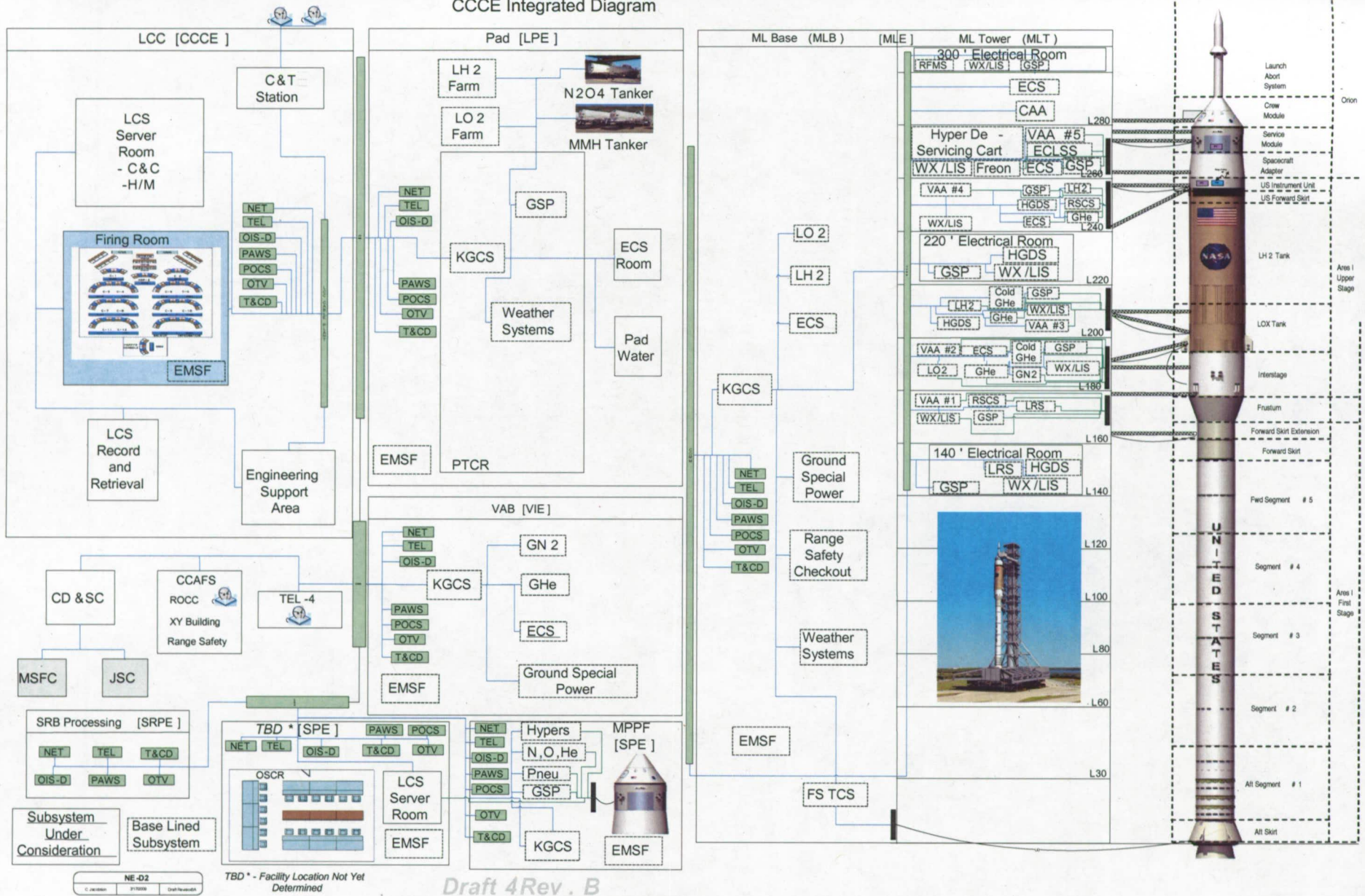

Figure 3, GEIT Integrated Diagram

The primary goals of the GEIT are as follows:

- (a) to validate Ground Systems design by demonstrating the interoperability, functionality, and stability of the ground elements, subsystems and components as an integrated ground system before they are used to process and launch a Constellation Program (CxP) launch vehicle for the first time
- (b) to validate critical ground processing activities and procedures in the operational environment prior to their first-time execution with flight hardware
- (c) to validate ground test team readiness to support flight vehicle processing and launch operations

Ground Element Integration Test Configurations

Based upon the location of when multiple ground element testing will occur there are three possible candidate configurations and general test configurations for GEIT testing that have been identified:

GEIT MPPF Test Configuration #1

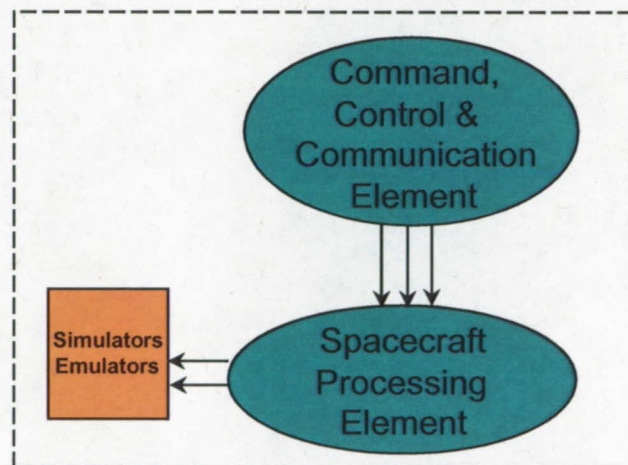

GEIT TEST #1 Test Objective -Validate subsystem compatibility by activating/operating the Space Craft Processing Element power/fluids/data subsystems through the umbilicals to flight simulators using Command Control and Communications Element in the Multi-Payload Processing Facility.

GEIT VAB Test Configuration #2

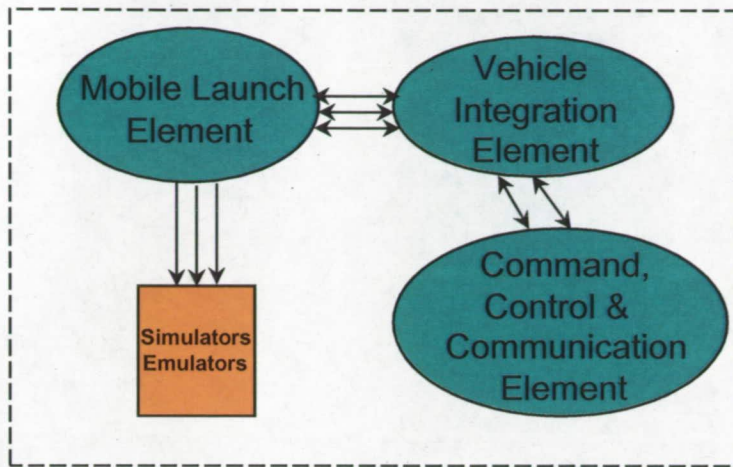

GEIT TEST #2 Primary Test Objective -Validate subsystem compatibility by activating/operating all subsystems through the umbilicals to flight simulators at all required locations using Command Control and Communications Element in the Vehicle Assembly Building.

GEIT Launch Pad Test Configuration #3

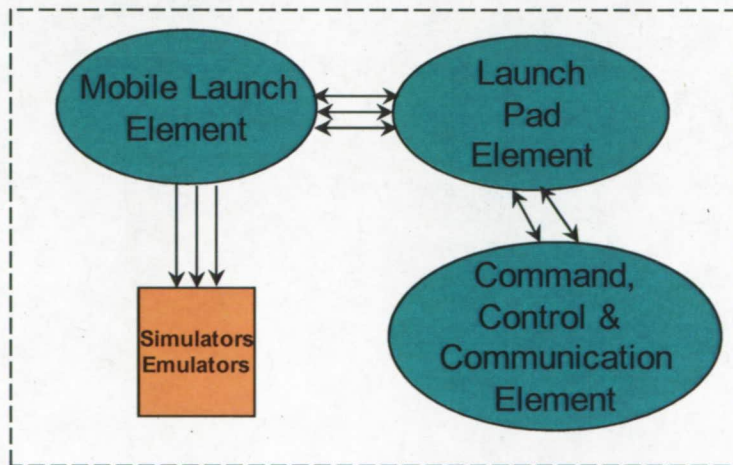

GEIT TEST #3 Primary Test Objective -Validate subsystem compatibility by activating/operating all subsystems through the umbilicals to flight simulators at all required locations using Command Control and Communications Element at the launch pad.

GEIT Test #1 Multi Payload Processing Facility (MPPF) Summary

The GEIT Test #1 will include integrated testing necessary to validate the elements and subsystems in a "day of test" configuration. The objectives will be to configure the Spacecraft Processing Element (SPE) provided subsystem along with the Command Control Communication Element (CCCE) hardware/software and a set of a test equipment simulating the vehicle to perform a set of activities that involve commanding the vehicle, providing power and commodity servicing using remotely controlled manually activated systems retrieving, sending and storing data. (Reference Figure 3 for GEIT integrated diagram). Real-time operational data will be captured locally in the Orion Launch Control System.

GEIT MPPF Test #1 Implementation

The overarching goal is to ensure that the elements and subsystems operate as intended in the operational environment as a whole to affect final validation. The nominal hazardous operations will be performed in serial rather than parallel. Therefore only one simulated hazardous operation will be performed during GEIT Test #1. The GO₂ subsystem was chosen to support GEIT Test #1, mainly because it interfaces with auxiliary subsystems, GHe, GN₂, R134A refrigerant and a Launch Control System set. Refer to Figure 4 for test configuration.

Each subsystem will be configured in a sequence representative of the nominal activation. Procedures, which are run by operational engineers, will be used to configure and power up subsystems or integrated into GEIT procedures. This will help validate the ground test team readiness and ground procedures used during flight vehicle processing.

The GSE will be remotely operated to validate all redundant commands, safing controls, software operational programs, and monitoring. This system test will effectively characterize the interfaces between the subsystems. The outcome will ensure assets from both the CCCE and the SPE elements can work together as an integrated ground system.

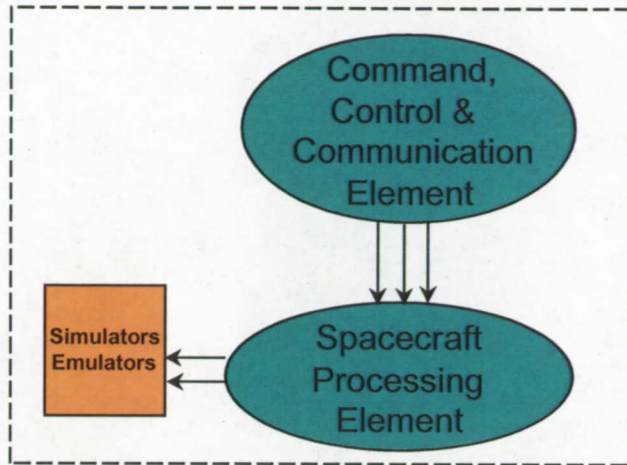

GEIT MPPF Test Configuration #1

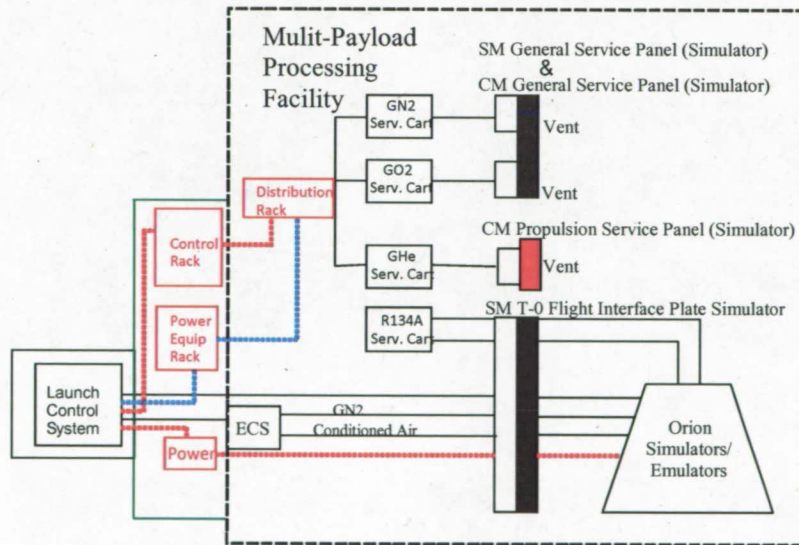

FIGURE 4, GEIT TEST #1 SETUP

GEIT TEST #2 In The Vehicle Assembly Building (VAB) Summary

The GEIT Test #2 will be performed in the VAB. The GEIT Test #2 will include integrated testing necessary to validate the ground elements and subsystems in a "day of test/launch" configuration. The primary objective will be to activate the Mobile Launcher Element (MLE), Vertical Integration Element (VIE) and the CCCE in order to perform a set of activities that involve commanding, providing power and commodity servicing between the elements to ensure all interfaces and functionality between each element are validated for all subsystems. Each subsystem will activate in the sequence that would be representative of the nominal subsystem. Procedures, which are run by operational engineers, will be used to configure and power up subsystems. This will validate the ground test team readiness and ground procedures used during flight vehicle processing and launch operations.

GEIT TEST #2 In The VAB Implementation

Following verification, the MLE and VIE would be configured for GEIT as shown in Figure 5. The Mobile Launcher will be located in the VAB high bay. All connections will be established between the MLE and the VIE. The GSE (flight emulators, simulators and load banks) will be appropriately located in the required locations within the ML tower.

The umbilical arms will be attached in the stowed position vertically up against the ML tower. The flight simulated umbilical plates will be attached to the ground umbilical plates and cables and fluid lines will be attached from the flight plates to the simulators, emulators and load banks.

Once the setup for the integrated test scenario is complete, all subsystems will be activated and ready to perform the GEIT Test #2 in order to validate subsystem compatibility given max power, gas flow, access configuration, electromagnetic compatibility and RF environment.

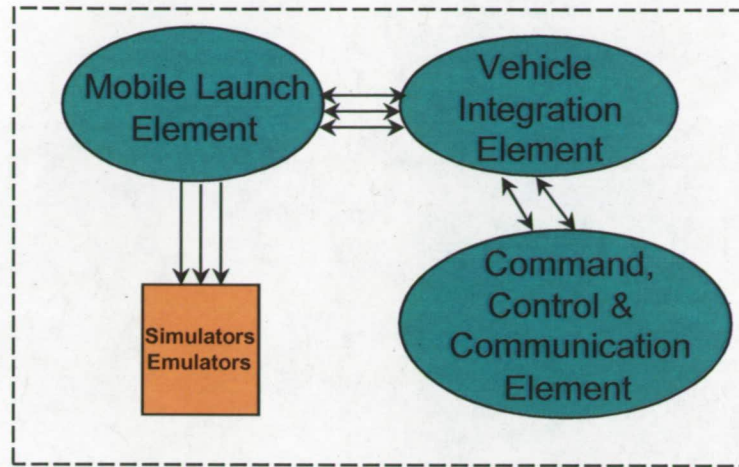

GEIT VAB Test Configuration #2

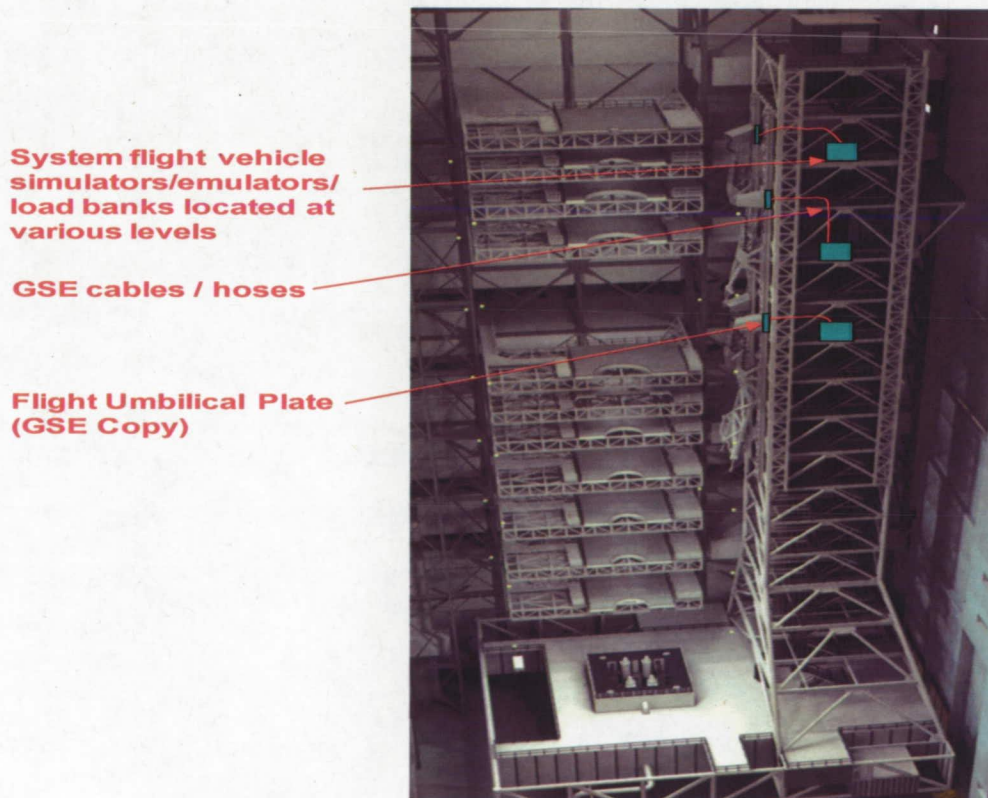

Figure 5, GEIT Test #2 Setup

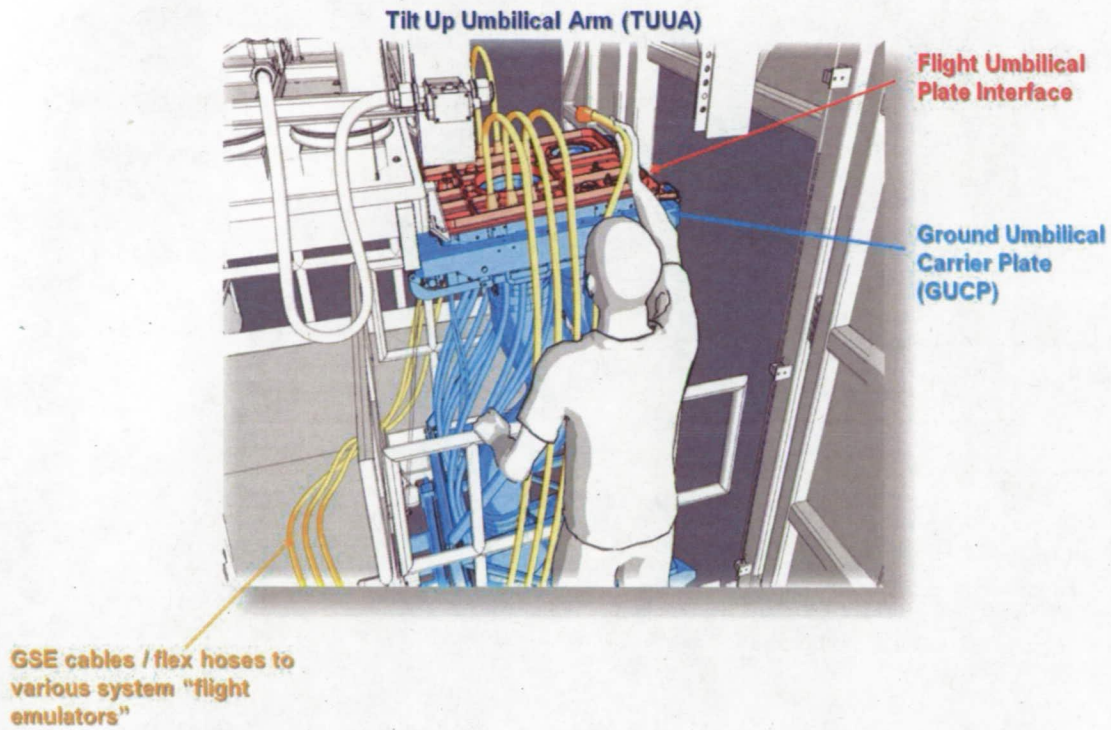

Figure 6, Ground Umbilical Plates Attached to Flight Umbilical Plates



Figure 7, Emulators/Simulators Attached to Flight Umbilical Plates

GEIT Test #3 At The Launch Pad Summary

The Launch Pad Element (LPE) GEIT will include integrated testing necessary to validate the elements and subsystems in a "day of test/launch" configuration. The objectives will be to configure the MLE, LPE and the CCCE to perform a set of launch preparation activities that involve commanding, providing power and commodity servicing between the elements to ensure all interfaces and functionality between each element are validated for all subsystems. The overarching goal is to ensure the elements and subsystems operate as intended in the operational environment as a whole to affect final Ground System validation. Each subsystem will be configured in a sequence representative of the nominal activation. Procedures, run by operational engineers, will be used to configure and power up subsystems. This will validate the ground test team readiness and ground procedures used during flight vehicle processing and launch operations.

GEIT Test #3 Launch Pad Implementation

The Mobile Launcher will roll out to the launch pad with umbilical arms attached to the tower and simulators and emulators remaining in the Mobile Launch Tower during transit. Following verification, the Mobile Launcher and pad would be configured for GEIT as shown in Figure 8. All subsystems will be configured and activated for GEIT Test #3:

Once the setup for the integrated test scenario is complete, perform the GEIT Test #3 to validate subsystem compatibility given max power, gas flow, access configuration, electromagnetic capability and RF environment.

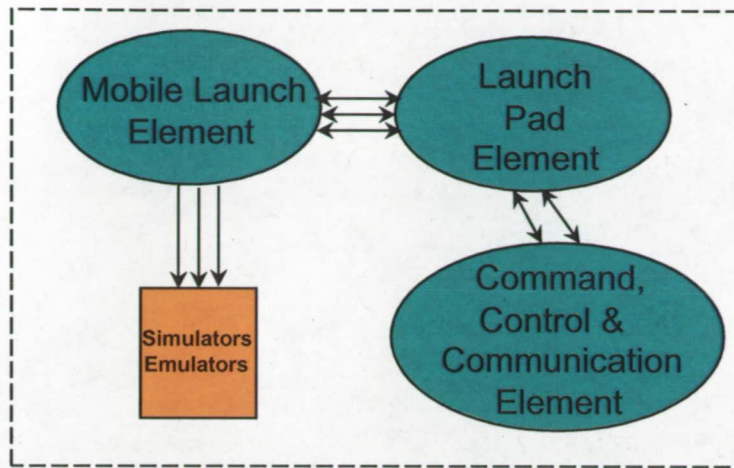

GEIT Launch Pad Test Configuration #3



**Flight simulators/emulators
and load banks located at
various levels of tower**

Figure 8, GEIT Test Setup #3

Turnover and Ready To Support Flight Testing

As part of GEIT, the operational community will develop test procedures and run the operational tests with the design engineer's assistance in trouble shooting and modifying design if required. The operational community will be able to train the personnel while validating test procedures. At the completion of the final GEIT, Ground Systems will be ready for turnover to the operational organization. By post turnover or the Operational Readiness Date (ORD) the operational community is ready to process the launch vehicle.

Traditional method would have meant post turnover (ORD) would still need operational procedures to be developed, process to be exercised and the personnel to be trained. For example an Operational Readiness Test would still need to be performed. If there were any design modifications required due to problems during testing the cost impact would be significant because the item tested would have already been turned over and under formal configuration. Because of the innovative approach of combining the operational tests with GEIT, the schedule duration would be shortened by approximately thirty days.

Traditional Approach

Traditionally in previous programs, Ground Operations performed all V&V activities in a serial manner utilizing a step function. Each step required verification then validation before proceeding to the next level. The verification and validation process had to be repeated through each step of the approach beginning with components, leading to subsystems, followed by elements, ultimately ending with ground system operational readiness. Once all V&V requirements were met, design engineering would then turn over the system to operations engineering for operational readiness tests and reviews prior to declaring Ground Systems operational ready to process flight hardware.

Utilizing this traditional step function method of incremental build creates overlap and duplication of test activities. Since these activities were performed in serial the duration extended months longer than the current innovative approach being adopted by Ground Systems for the Constellation Program.

Traditional

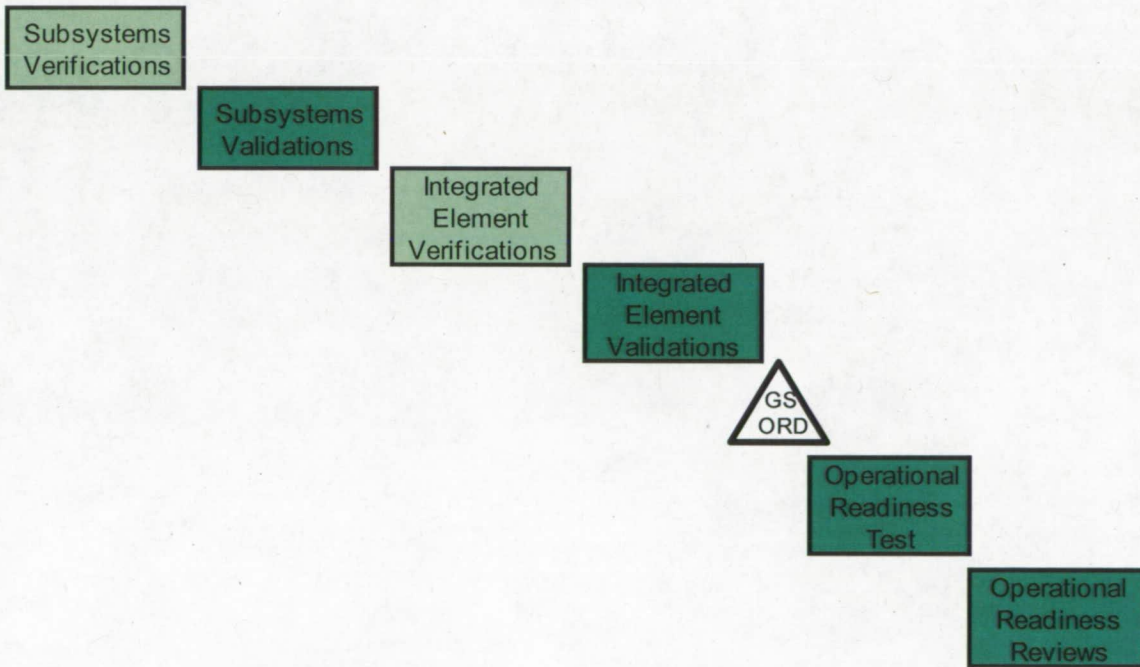

Innovative Approach

The complexity of developing the Constellation Ground Systems is not only the management of intertwining thousands of components contained within over seventy subsystems that span across multiple elements, but it is also inclusive of the management of the people and integration of the multiple designs, operational and institutional organizations. In order to orchestrate this complex, multi-organizational project the need for strategic planning and innovative approaches is crucial to our success.

The ability to bring the operations organization online during verification allows for validation to be combined with verification. Subsystem and element V&V will be performed in parallel allowing the V&V requirements to be satisfied by both the design/development and operations engineering communities together as a team.

Instituting a streamlined process by performing GEIT satisfied the integrated element to element V&V requirements by testing end to end interface functionality and interoperability between elements having all the elements up and running with operational processes and procedures. The GEIT also satisfies the need to perform the Operational Readiness Test which is required by the operations community because it exercises the personnel, processes and procedures. Inclusion of the Operational Readiness Test satisfied within GEIT eliminates the need to perform additional operational readiness testing after the Operational Readiness Date, thereby eliminating that major task which typically occurred after the Operational Readiness Date.

Innovative

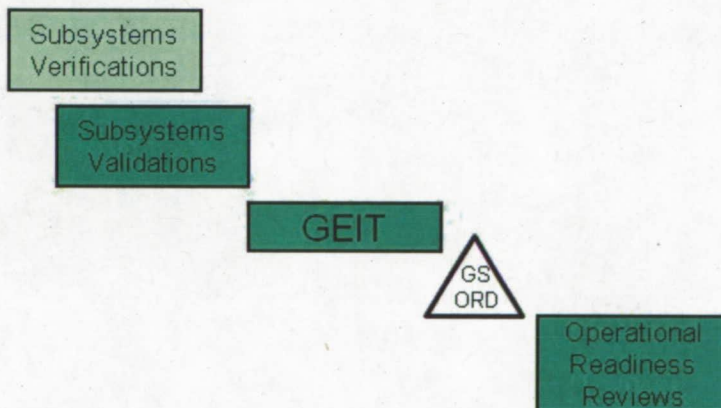

Reducing the amount of serial testing assumes the risk of finding anomalies near the end of the development schedule. However, this is an acceptable risk given the strict constraints on the schedule and budget put on the Constellation Program.

The innovative, strategic approach minimizes budget and schedule by performing the GEIT streamline operation of linear testing by combining the Operational Readiness Test with GEIT. This method will allow GOP to satisfy the program's allocated requirements and prove to the CxP that GOP is ready to support nominal ground operation processing.

Summary & Conclusion

Developing a new space transportation system and supporting infrastructure presents a unique set of complicated challenges. This type of all-inclusive launch site development is unprecedented since the time of Apollo. Utilizing a combination of traditional and innovative strategies for V&V will fulfill the numerous, complex challenges of implementing the launch site ground infrastructure. The core of these strategies consists of an innovative, streamlined approach to V&V. Bringing the operations organization online during subsystem and element verification allows for some of the validation to be combined with verification, which dramatically reduces time and cost issues. Furthermore, comprehensive end-to-end validation test (GEIT) of the complete launch site, satisfies the integrated element to element V&V. Finally, having the ability during GEIT to exercise not only hardware but the personnel, processes and procedures thereby eliminates the need for additional Operational Readiness Testing. This comprehensive, reorganized course of action allows the Ground Operations Project to progress and stay within the limited budget and schedule constraints for developing launch site ground infrastructure for the Constellation Program.

It is imperative that during the implementation of V&V, not only are the multi-organizations tightly coupled, but these organizations are able to orchestrate the highly integrated components, subsystems and elements to demonstrate end-to-end interoperability of Ground Systems.

This paper outlined strategies and provided high level planning for meeting the challenges to ensure success that the GOP is ready to support nominal ground operations processing for the Constellation Program.

BIOGRAPHIES

Ms. Tammy Annis works for The Boeing Company in the area of Test and Verification (T&V) for the Constellation Ground Operations Project at Kennedy Space Center (KSC). She provides leadership in defining verification strategies and requirements for ground systems used to perform ground operations at the launch, landing and retrieval sites. In addition, she is developing a multi-ground element integration test concept and planning for ground systems. She is also responsible for developing and documenting the verification and validation processes and planning for Ground Systems. For two decades she has designed, verified and certified Ground Support Equipment for the Space Station Program. Tammy has also held the position of the Integrated Project Lead for Simulators and Emulators for the Space Station Program. In addition, she holds a BS in Electrical Engineering from the University of Central Florida.

Mr. Honeycutt started his career with NASA at the Kennedy Space Center (KSC) in 1990, shortly after his graduation from Auburn University. He currently works in the KSC Ground Operations Project Office leading the planning of integrated Test and Verification (T&V) activities at KSC for the Constellation Program (CxP). He also provides leadership and technical management in defining verification strategies and requirements for ground systems used to perform ground operations at the launch, landing and retrieval sites. He serves as the primary technical interface between the CxP and KSC concerning integrated T&V issues. Earlier in Tim's career, he worked numerous years for the International Space Station (ISS) Directorate at KSC. He performed various roles in the ground processing of flight hardware, including Multi-Element Integration Testing (MEIT) of ISS flight elements and the development of ground support equipment. Tim also worked in the Design Engineering Directorate at KSC as a Senior Communications Engineer.



CONSTELLATION

Ground Element Integration Test (GEIT) at Kennedy Space Center

Tammy Annis

October, 2009



Ground Systems & Elements



CONSTELLATION SYSTEMS

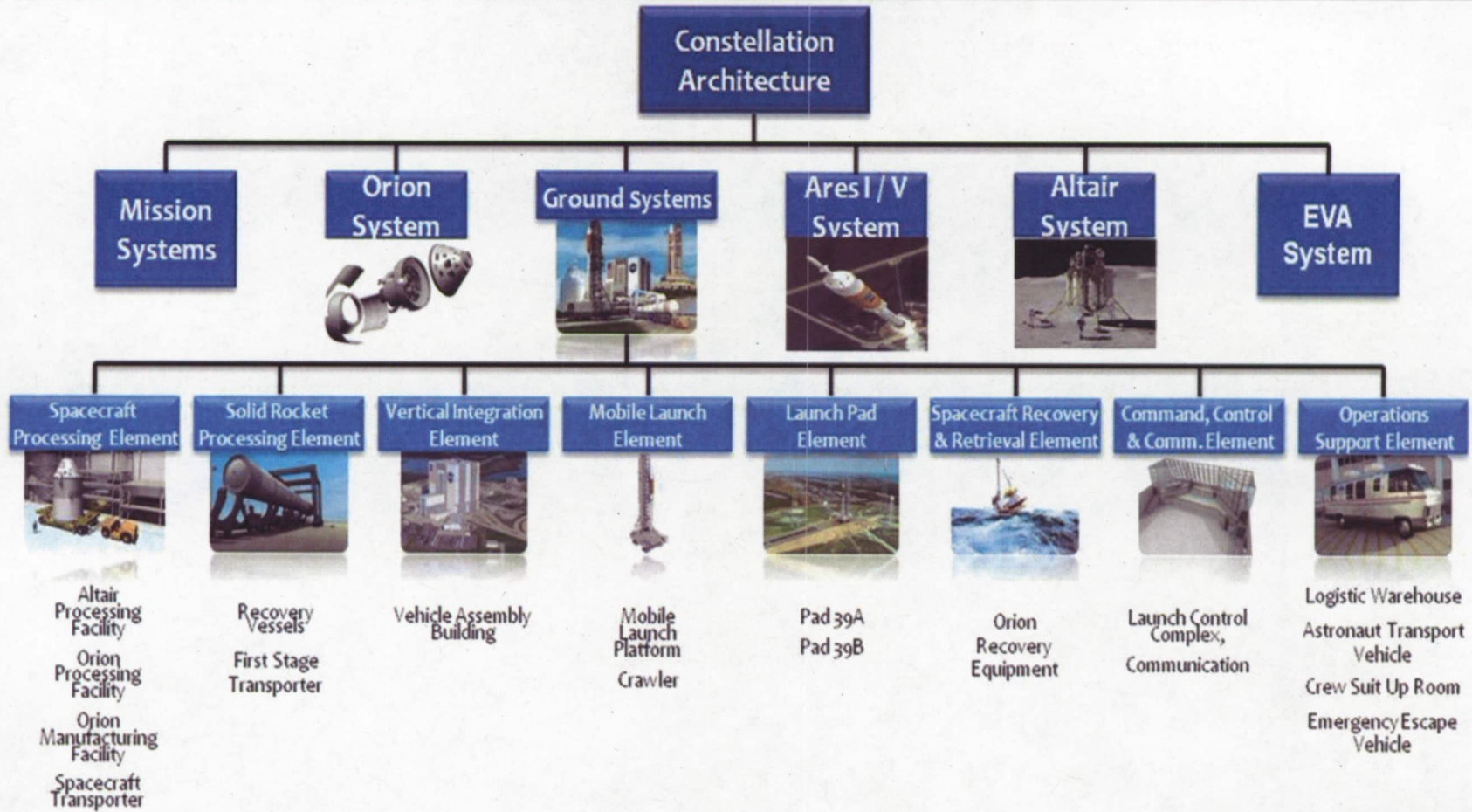

Ground Systems is that part of the CxP architecture which includes facilities, infrastructure, facility systems and support equipment hardware and software required to perform KSC ground operations for the purpose of receiving, processing, integrating, testing, servicing, launching, recovering, deservicing and deintegrating CxP flight systems.

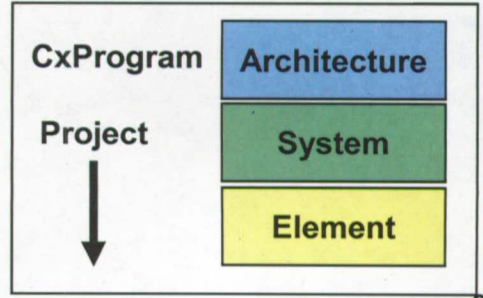



Ground Systems Verification & Validation



GEIT (Ground Systems Validation)

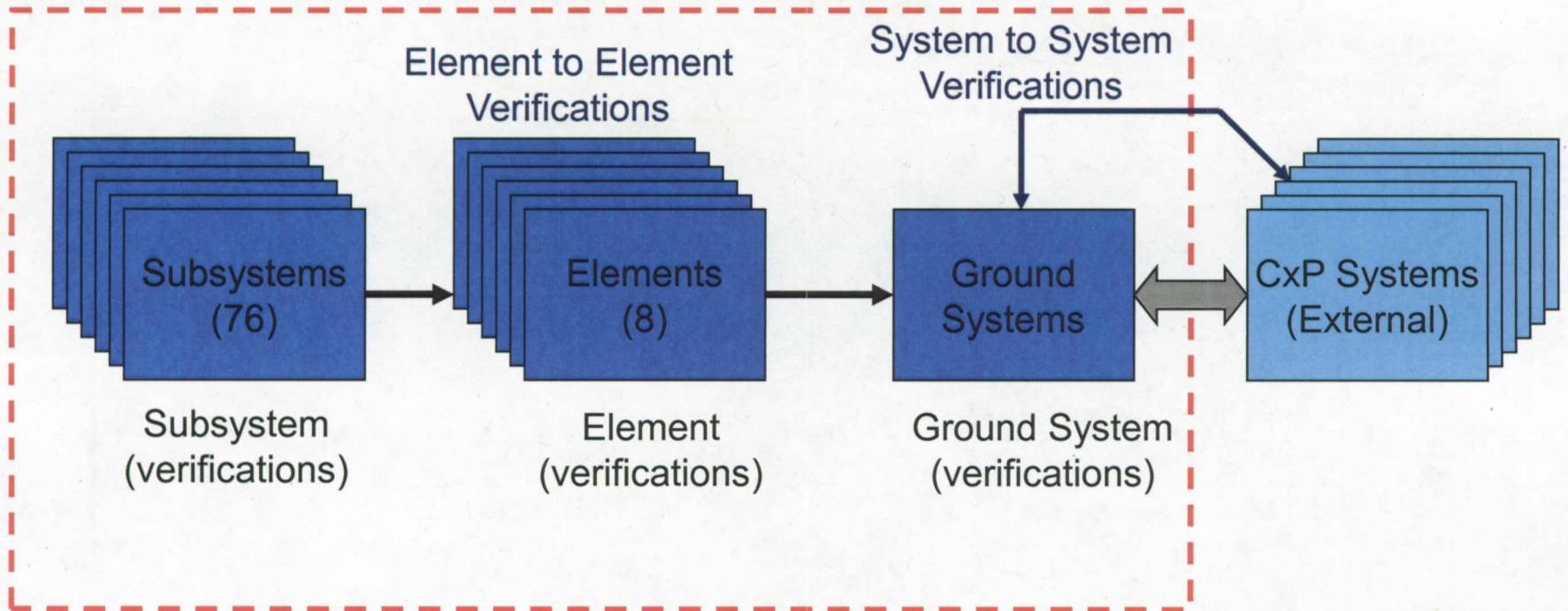



Verification & Validation for Subsystem and Elements

LO2 Servicing Subsystem breakout example



CONSTELLATION SYSTEMS

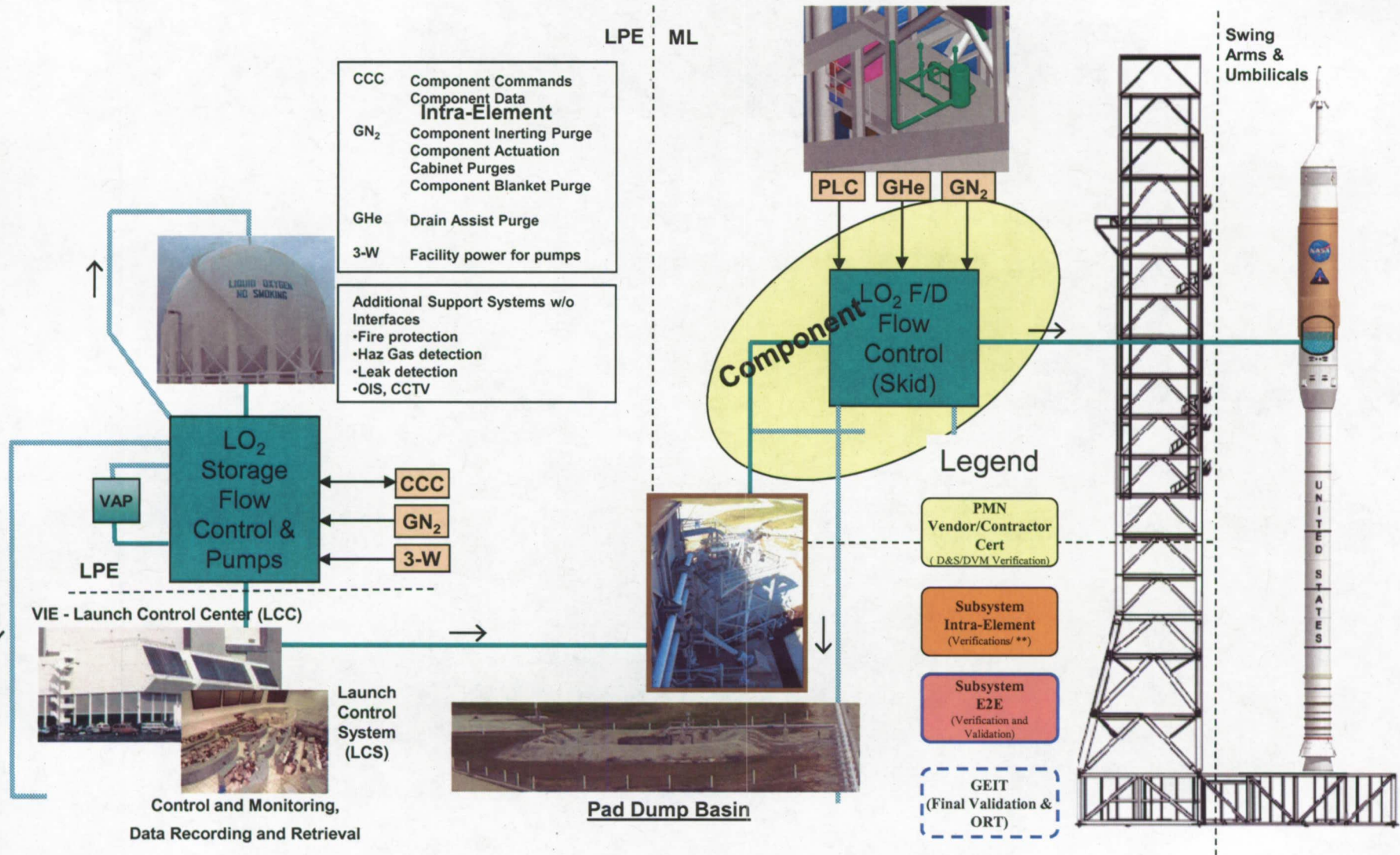



Verification & Validation for Subsystem and Elements

LO2 Servicing Subsystem breakout example



CONSTITUTION SYSTEMS

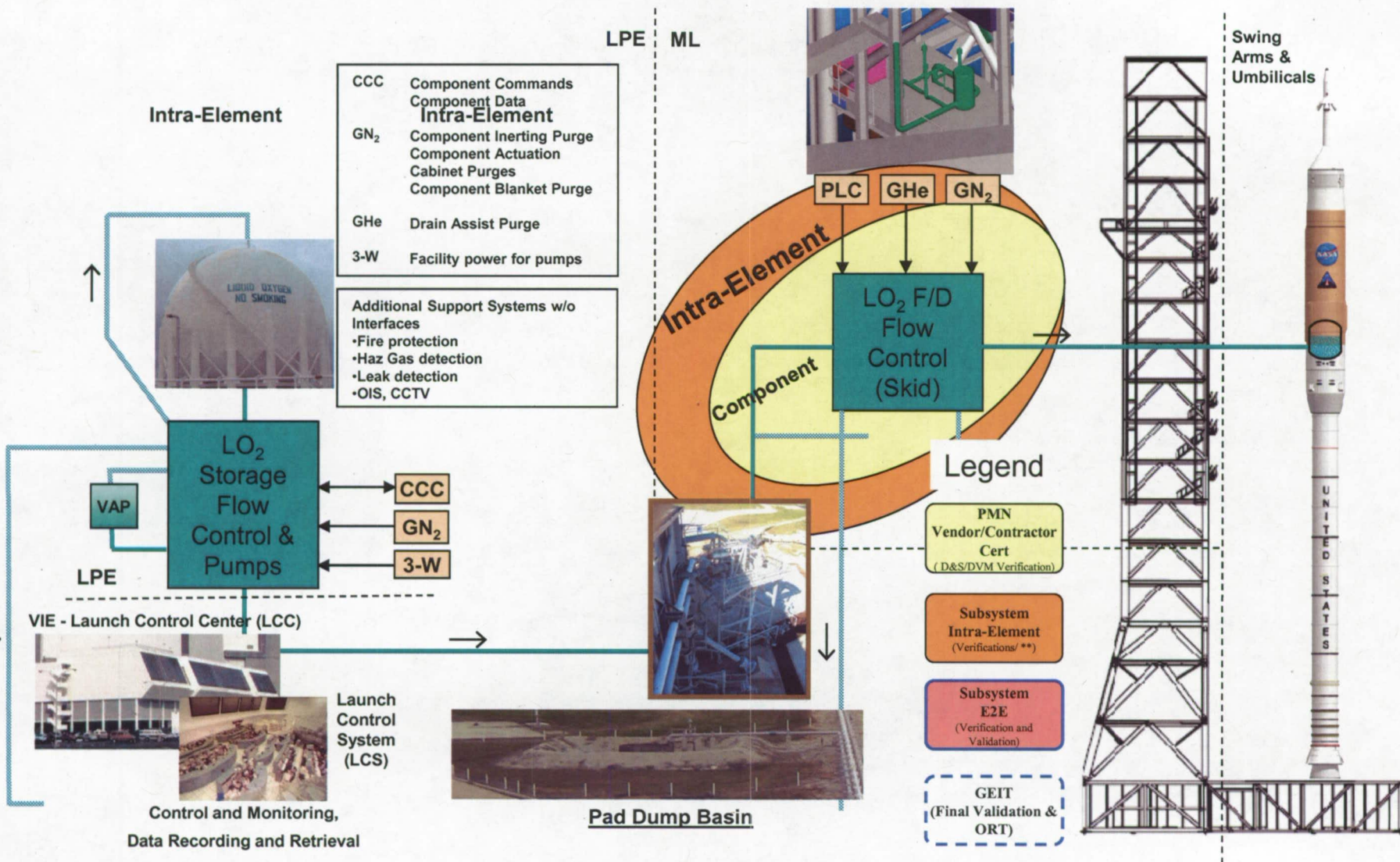



Verification & Validation for Subsystem and Elements

LO2 Servicing Subsystem breakout example



CONSTELLATION SYSTEMS

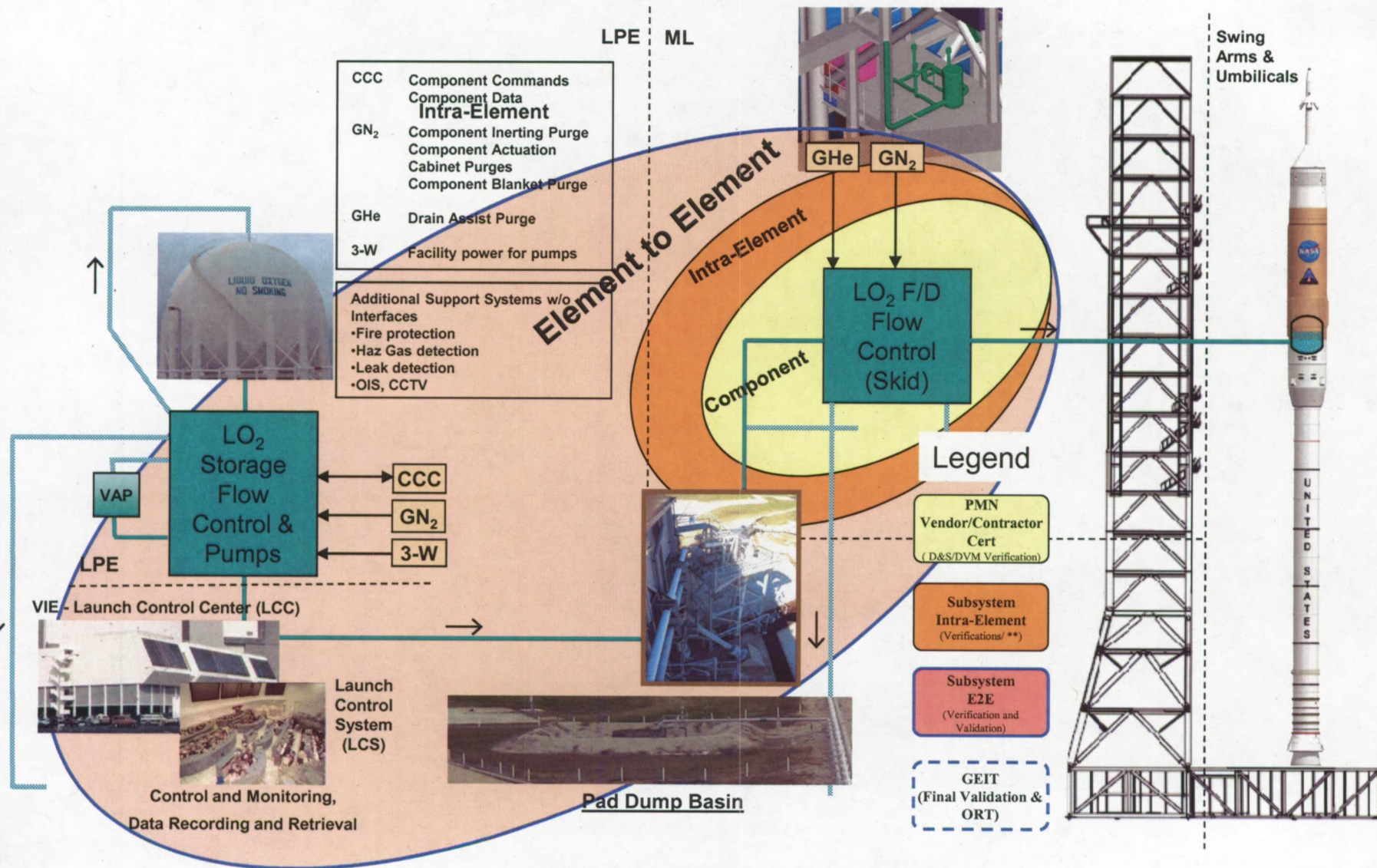



Verification & Validation for Subsystem and Elements

LO2 Servicing Subsystem breakout example



CONSTITUTION SYSTEMS

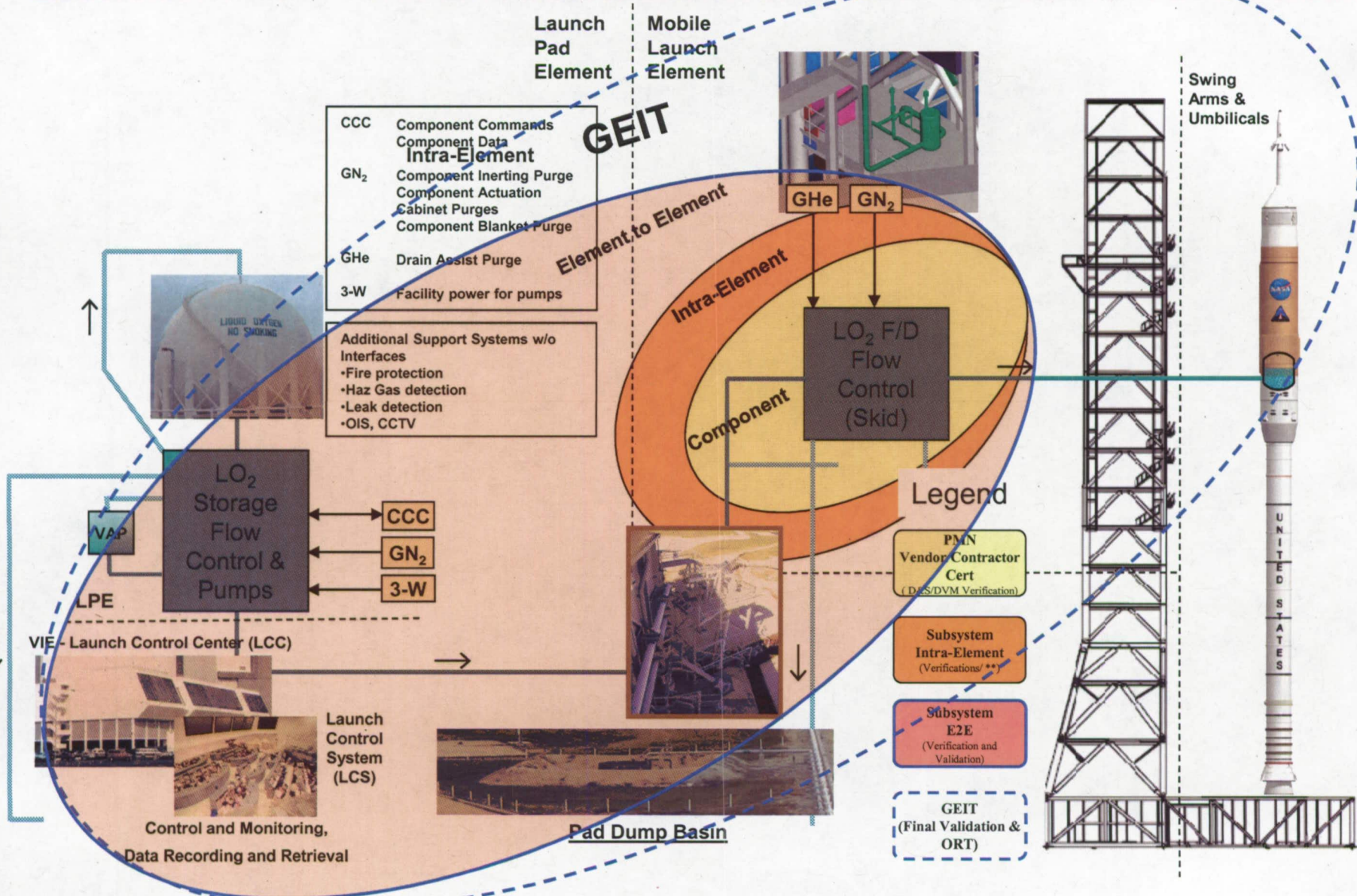



GEIT



GEIT: An integration test between multiple GOP ground elements in order to validate Ground Systems prior to processing the first flight test vehicle.

- These tests will occur after the Ground Elements has been verified.

The primary objectives of the GEIT are:

- To validate Ground Systems design by demonstrating the interoperability, functionality, and stability of the ground elements, subsystems, and components as an integrated ground system before they are used to process and launch a Constellation Program (CxP) launch vehicle for the first time.
- To validate critical ground processing activities and procedures in the operational environment prior to their first-time execution with flight hardware.
- To validate Ground Test Team readiness to support flight vehicle processing and launch operations.



GEIT Elements



CONSTELLATION SYSTEMS

Constellation Program

Constellation Architecture

Ground Ops Project

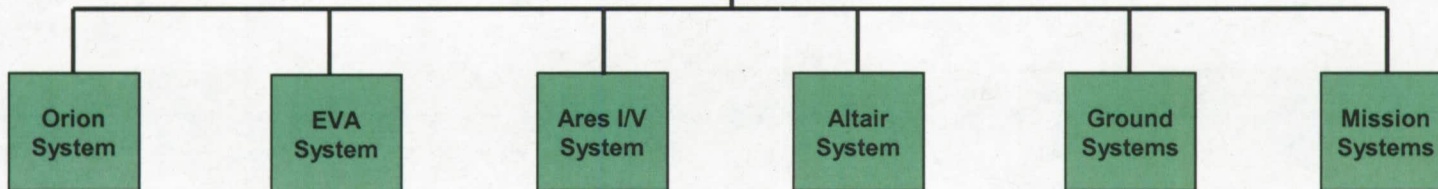

Ground Systems Elements

GEIT Elements to be Tested

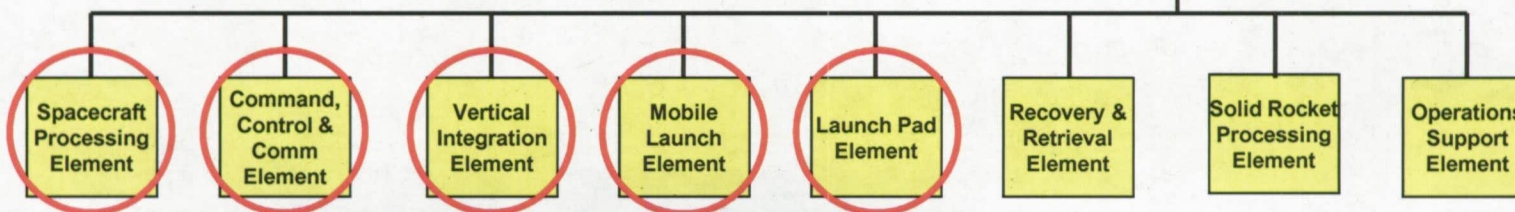

Subsystem 1

Subsystem 2

Subsystem 3

Subsystem 4

⋮

Subsystem 76

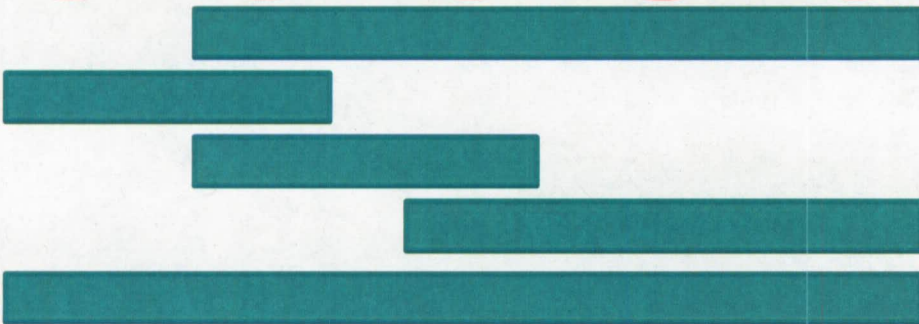



Subsystems/Elements Integrated Diagram



CONSTELLATION SYSTEMS

CCCE Integrated Diagram

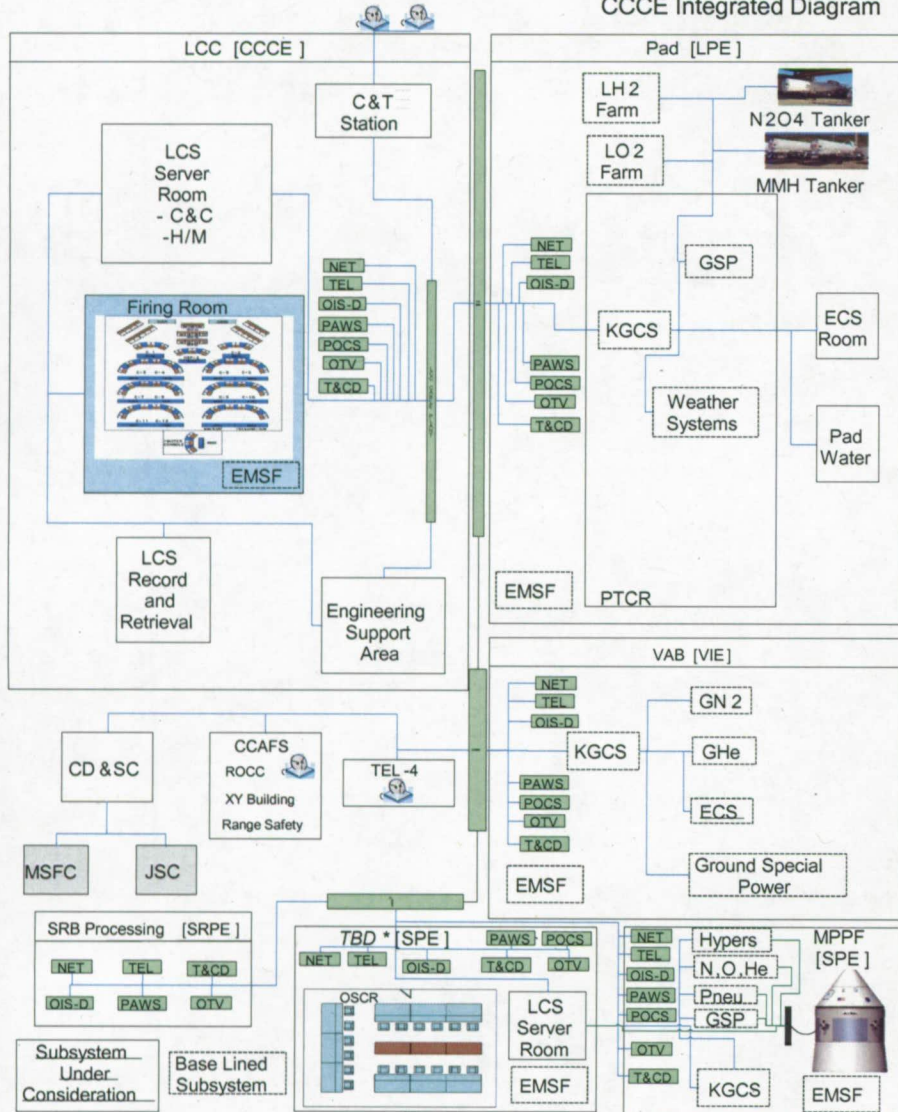

*Simulators/Emulators will be used in place of Vehicle

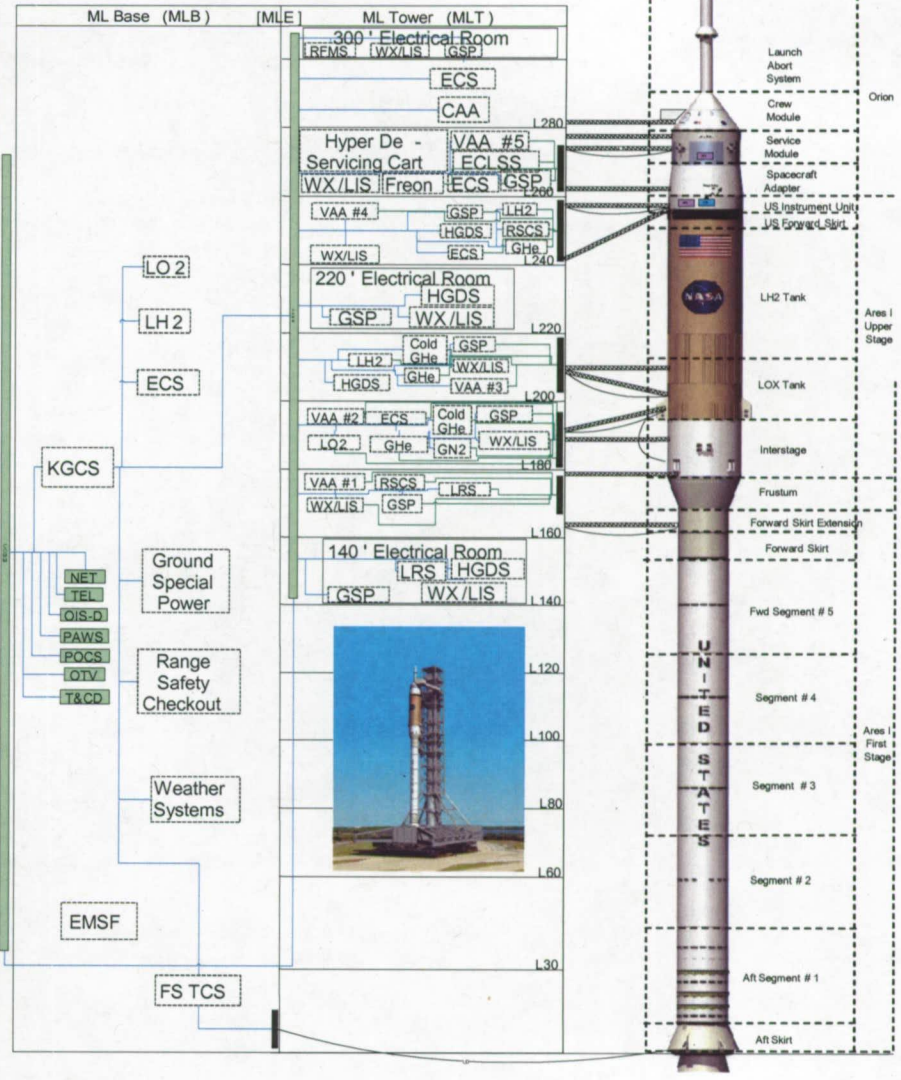

NE-02
C. Jackson 3/17/08 Distribution 4

TBD * - Facility Location Not Yet Determined

Draft 4 Rev. B



GEIT Test #1 at MPPF

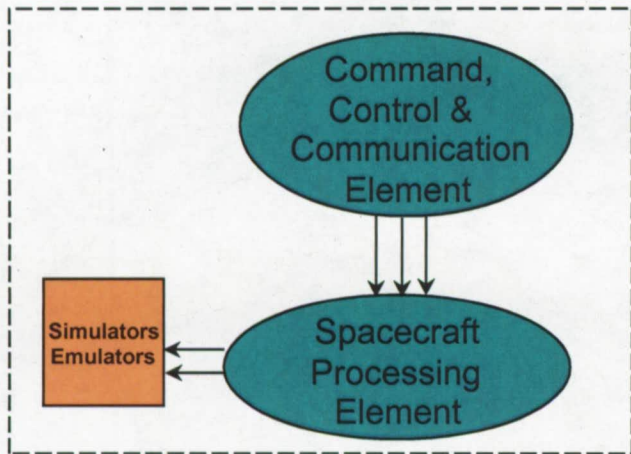

GEIT MPPF Test Configuration #1
(1/4/13 – 2/1/13)

- The nominal hazardous operations will be performed in serial rather than parallel. Therefore only one hazardous operation will be performed during GEIT Test #1.
- The GO2 subsystem was chosen to support GEIT Test #1, because it interfaces with auxiliary subsystems, GHe, GN2, R134A refrigerant, and a MPPF LCS set.

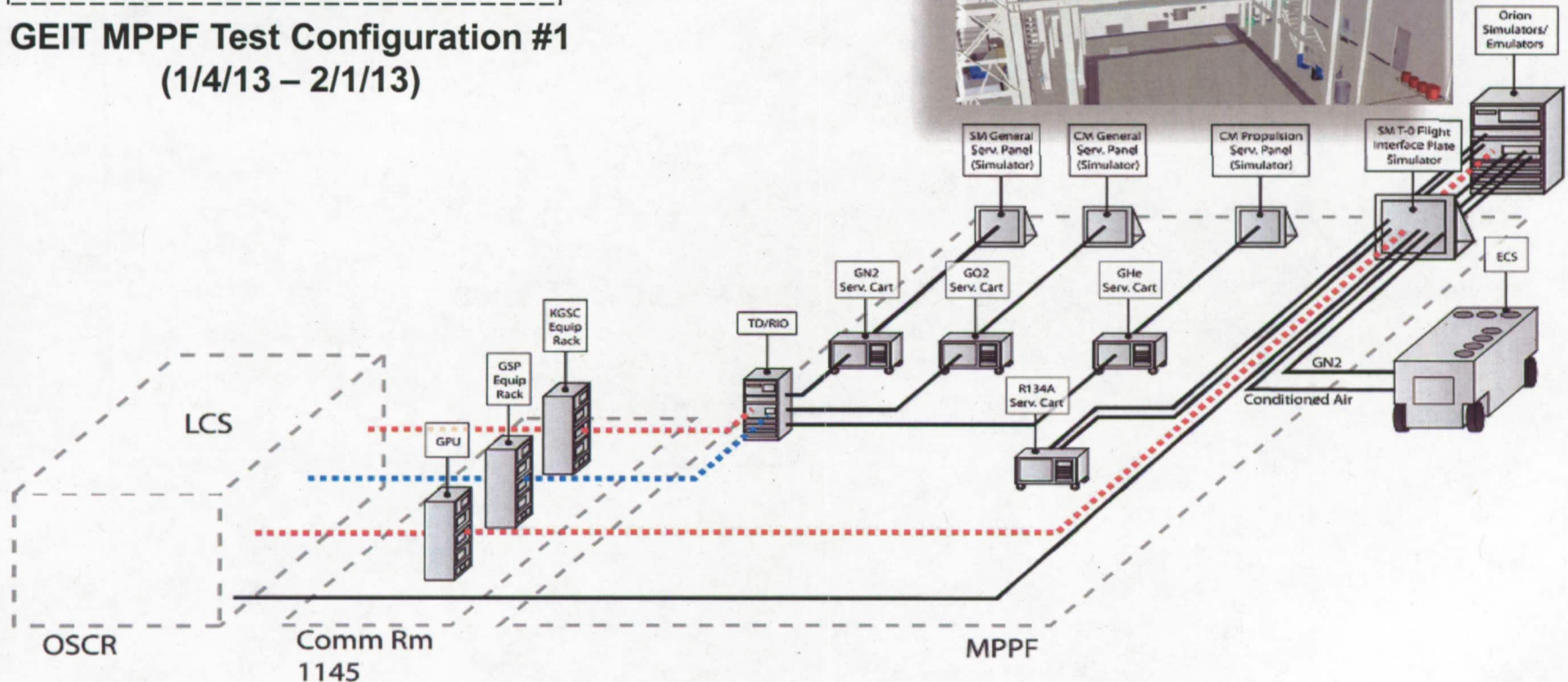
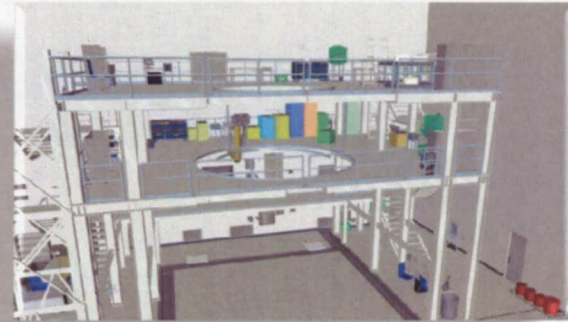



GEIT Test #2 at VAB



- No vehicle present
- Simulators/Emulators/Load Banks all on ML Tower

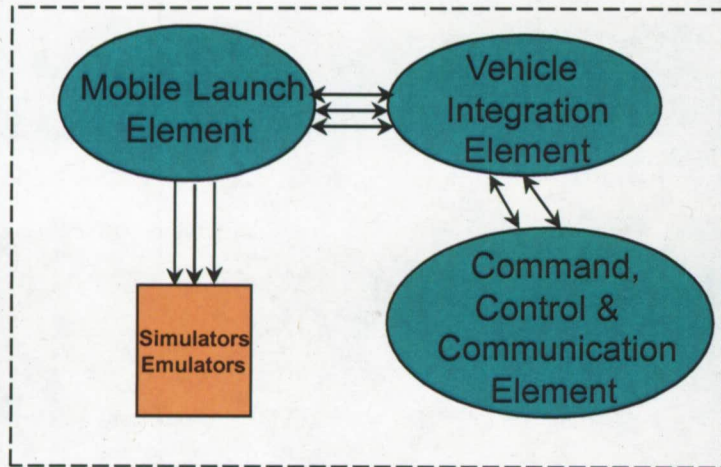

GEIT VAB Test Configuration #2
(3/11-29/13)

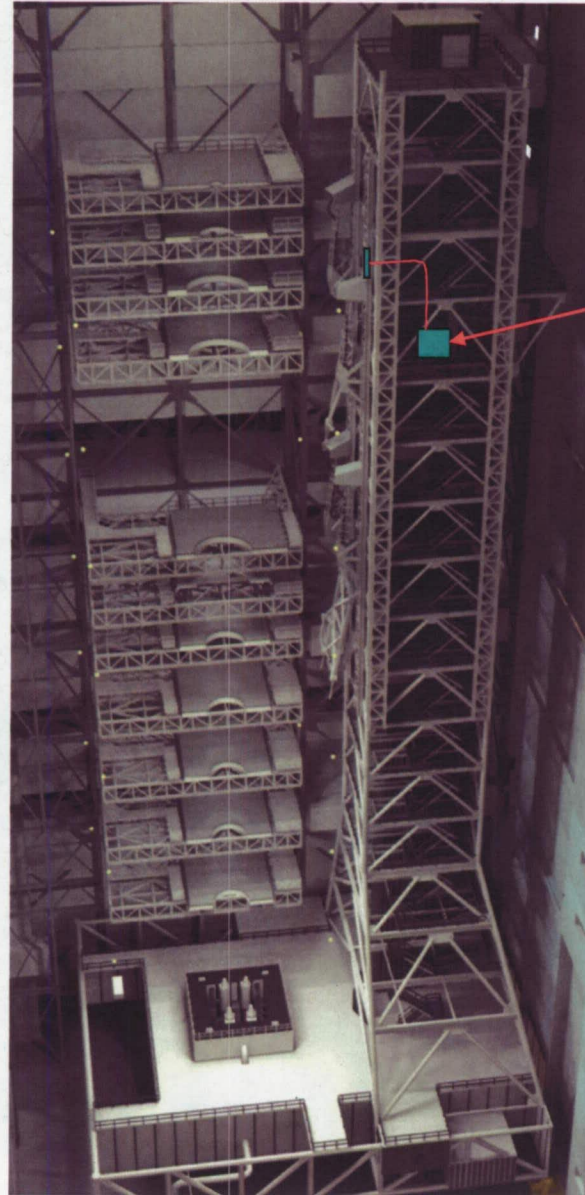

System flight vehicle simulators/emulators/load banks located at various levels



GEIT Test #2 at VAB



CONSTITUTION SYSTEMS

Tilt Up Umbilical Arm

GSE cables / flex hoses to various system "flight emulators"

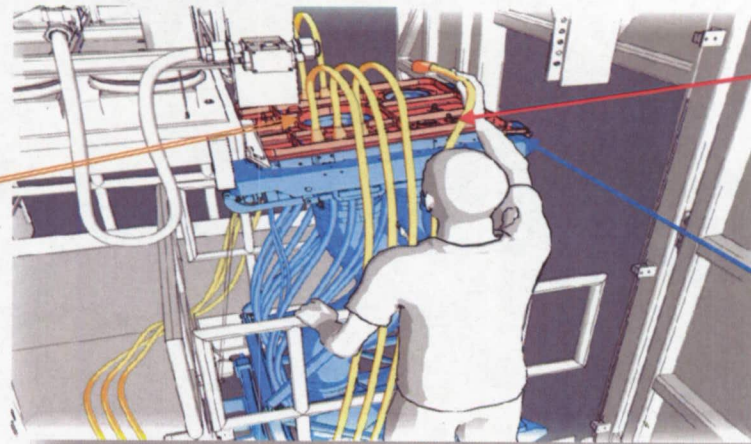

Flight Umbilical Plate Interface

Ground Umbilical Carrier Plate

Orion Emulator/Simulator

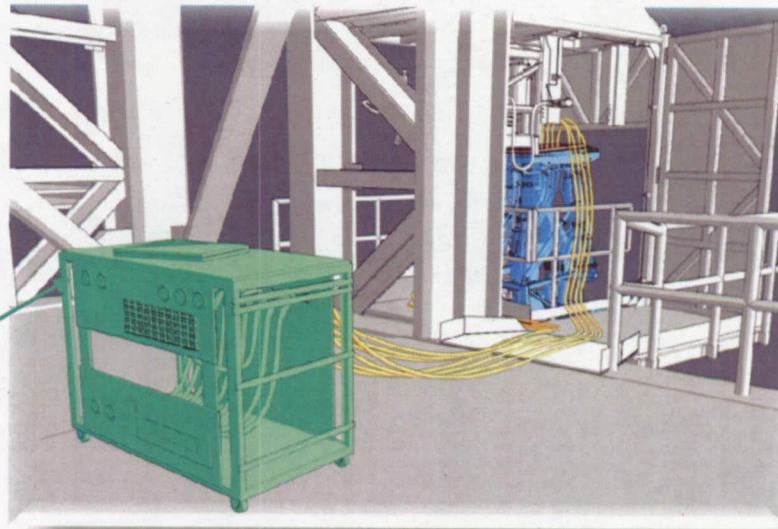

GSE Test Configuration



GEIT Test #3 at Pad



CONSTELLATION SYSTEMS

- No vehicle present
- Unable to perform wet dress for LOX/LH2
- Unable to perform T-0 disconnect



**System flight vehicle
simulators/emulators/load
banks located at various levels**

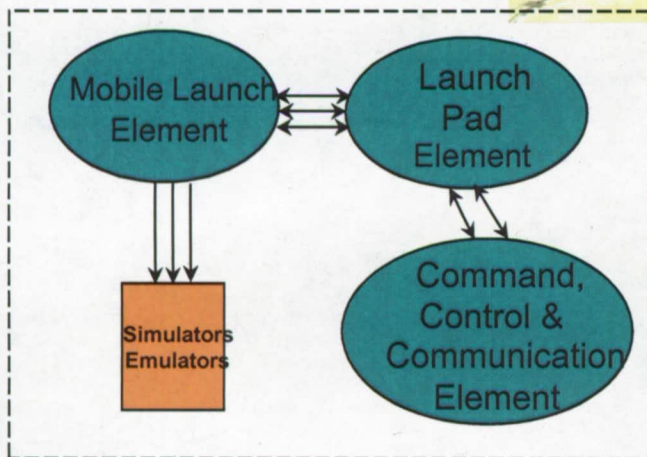

**GEIT Launch Pad
Test Configuration #3
(7/5/13 – 8/1/13)**



Traditional Approach



Traditional

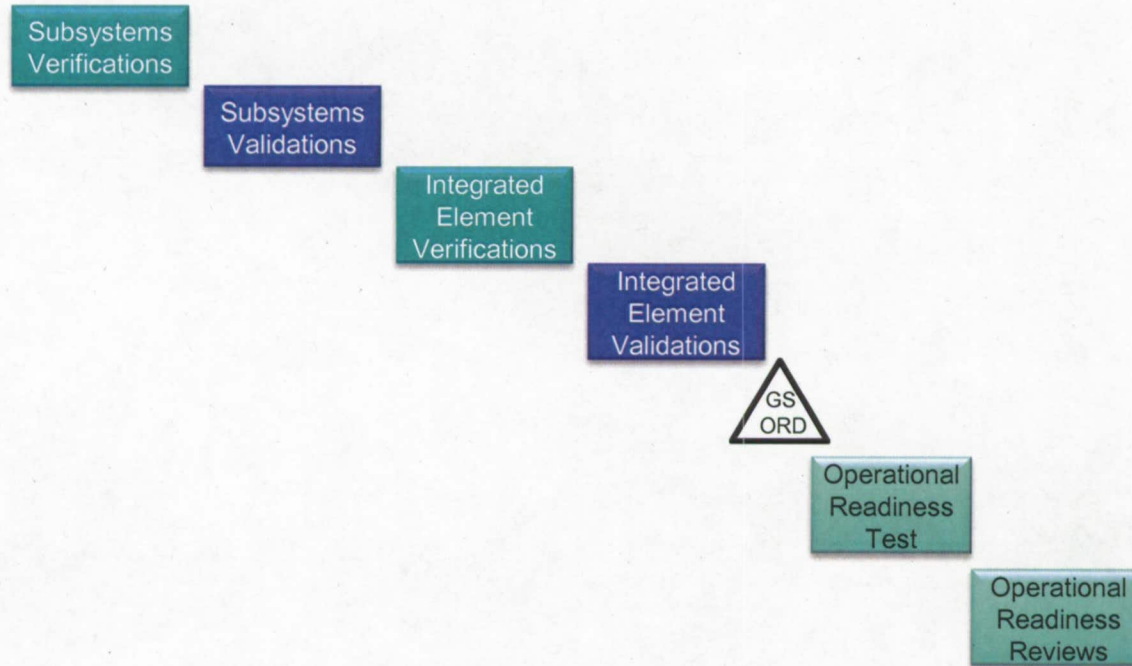

- Ground Operations performed all V&V activities in a serial manner utilizing a step function.
- Each step required verification then validation before proceeding to the next level.
- The verification and validation process had to be repeated through each step of the approach beginning with components, leading to subsystems, followed by elements, ultimately ending with ground system operational readiness.



Innovative Approach



Innovative

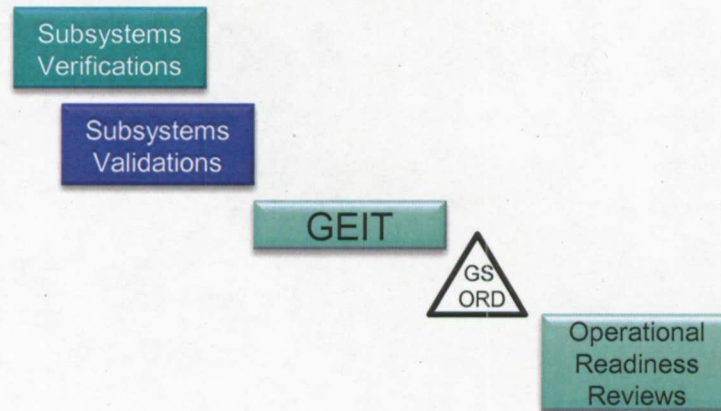

- **Subsystem and element V&V are now performed in parallel allowing the V&V requirements to be satisfied by both the design/development and operations engineering communities together as a team.**
- **Performing GEIT satisfied the integrated element to element V&V requirements by testing end to end interface functionality and interoperability between elements**
- **The GEIT also satisfies the need to perform the Operational Readiness Test which is required by the operations community because it exercises the personnel, processes and procedures**



Conclusion



- **Bringing the operations organization online during subsystem and element verification allows for some of the validation to be combined with verification, which dramatically reduces time and cost issues.**
- **Furthermore, comprehensive end-to-end validation test (GEIT) of the complete launch site, satisfies the integrated element to element V&V.**
- **Finally, having the ability during GEIT to exercise not only hardware but the personnel, processes and procedures thereby eliminates the need for the Operational Readiness Test.**
- **Not only are the multi-organizations tightly coupled, but these organizations are able to orchestrate the highly integrated components, subsystems and elements to demonstrate end-to-end interoperability of Ground Systems.**
- **This comprehensive, reorganized course of action allows the Ground Operations Project to progress and stay within the limited budget and schedule constraints.**