

General Disclaimer

One or more of the Following Statements may affect this Document

- This document has been reproduced from the best copy furnished by the organizational source. It is being released in the interest of making available as much information as possible.
- This document may contain data, which exceeds the sheet parameters. It was furnished in this condition by the organizational source and is the best copy available.
- This document may contain tone-on-tone or color graphs, charts and/or pictures, which have been reproduced in black and white.
- This document is paginated as submitted by the original source.
- Portions of this document are not fully legible due to the historical nature of some of the material. However, it is the best reproduction available from the original submission.

Commonality of Ground Systems in Launch Operations

By

Shawn M. Quinn

Bachelor of Electrical Engineering (1990)
Georgia Institute of Technology

Master of Science Engineering (1994)
University of Central Florida

Submitted to the System Design & Management Program
In Partial Fulfillment of the Requirements for the Degree of

Master of Science in Engineering and Management

at the

Massachusetts Institute of Technology

May 2008

© 2008 Shawn Quinn. All rights reserved.

The author hereby grants to MIT permission to reproduce and to distribute publicly paper and electronic copies of this thesis document in whole or in part.

Signature of Author _____ Shawn M. Quinn
System Design & Management Program
May 9, 2008

Certified by _____ Jeffrey Hoffman
Thesis Supervisor
Professor of the Practice, Department of Aeronautics & Astronautics

Accepted by _____ Patrick Hale
Director, SDM Fellows Program

ABSTRACT

NASA is examining the utility of requiring a certain degree of commonality in both flight and ground systems in the Constellation Program. While the benefits of commonality seem obvious in terms of minimizing upfront development and long-term operations and maintenance costs, success in real, large-scale engineering systems used to support launch operations is relatively unknown. A broad literature review conducted for this paper did not yield a single paper specifically addressing the application of commonality for ground systems at any launch site in the United States or abroad. This paper provides a broad overview of the ground systems, captures historical and current application of commonality at the launch site, and offers suggestions for additional research to further develop commonality approaches.

Thesis Supervisor: Jeffrey Hoffman.

Title: Professor of the Practice, Department of Aeronautics & Astronautics

ACKNOWLEDGEMENTS

The breadth of the commonality assessments and conclusions reached in this thesis were made possible by the vast amount of information shared by my friends and co-workers. Their willingness to contribute to the body of knowledge captured in this thesis repeatedly reminded me of the unique can-do environment I am privileged to be a part of at the Kennedy Space Center. Therefore, I would like to extend my thanks to the following individuals: David Adcock, Keith Britton, Scott Colloredo, Bob Cunningham, Hector Delgado, Ted Drake, Bill Franklin, Terry Greenfield, Dennis Jenkins, Ira Kight, Elaine Liston, Kirk Lougheed, Dick Lyon, Larry Manfredi, Carry McCleskey, Larry Morgan, Don Pittman, Hibah Rahmani, Russel Rhodes, Jimmy Rogers, Bill Roy, Larry Schulz, Dave Shelton, Stephanie Sowards, Billy Stover, Bob Waterman, Phil Weber, David Welke, and Edgar Zapata.

My involvement in the SDM Program was made possible by the support of my management team at KSC. Their encouragement and willingness to accommodate the commitment required to complete this educational program is sincerely appreciated. I would like to extend my gratitude to Tip Talone, Shannon Bartell, Pepper Phillips and Jennifer Kunz.

At MIT, I would like to thank my thesis advisor, Jeffrey Hoffman, for his enthusiasm, guidance and unique perspectives; Oli de Weck, Ed Crawley, Tom Allen, Pat Hale, Jack Grace, and all the others who work to make SDM truly a world-class program.

I would like to thank my father, Ron Quinn and stepmother, Carol Quinn for encouragement at just the right times.

To my mother, Sharon Slater, and stepfather, John Slater, your unwavering commitment to see me through this program and doing what ever it takes when ever it was needed is greatly appreciated.

At home, I am surrounded by the finest people I know on the planet. They sacrificed at least as much as I did and in many cases more over the last two years. I would like to thank my two wonderful children, Katerina and Julianna, for brightening many long hours in front of the lap top with a simple smile or hug. You will have the opportunity to climb extraordinary academic mountains very soon and I want you both to remember what it takes!

To my wonderful wife and soul mate, Jackie Quinn, you have taken me to so many places in spirit and heart that were only a gleam in my mind's eye many years ago. Thank You.

Table of Contents

List of Figures	5
List of Tables	8
1 Introduction and Thesis Overview	10
2 Ground Systems Overview	14
2.1 Launch Site Object Process Diagrams (OPD)	14
2.2 Cape Canaveral	24
2.3 Apollo	26
2.4 Space Shuttle.....	41
2.5 International Space Station	48
2.6 Constellation	52
2.7 Current KSC Facility and Infrastructure Summary	68
3 Literature Review.....	70
3.1 Commonality Terms and Definitions.....	70
3.2 Platform Based Product Development.....	71
3.3 Commonality and Ground Systems	71
3.4 Challenges with the Application of Commonality.....	73
3.5 Literature Review Summary	74
4 Commonality Assessment Framework	75
4.1 Management and Planning.....	75
4.2 Levels of Commonality.....	80
4.3 Type of Commonality	80
5 Application of Commonality at the Launch Site	82
5.1 Apollo Program.....	82
5.2 Space Shuttle Program.....	88
5.3 Space Station Freedom/International Space Station Program	97
5.4 Constellation Program	106
5.5 Special Topic: Commonality within Facilities and Facility Systems	119
6 Summary and Forward Work.....	120
References.....	124

List of Figures

Figure 1: Early Space Shuttle Orbiter Ground Processing Concept [NASA]	11
Figure 2: Space Shuttle Orbiter in the Orbiter Processing Facility [NASA]	11
Figure 3: Interface between Shuttle Mobile Launch Platform and the Launch Pad [NASA]	12
Figure 4: Constellation Projects Budget Comparison.....	12
Figure 5: Launch Site Whole System Object Process Diagram	15
Figure 6: Launch Site Level 1 Object Process Diagram (1/3).....	17
Figure 7: Launch Site Level 1 Object Process Diagram (2/3).....	17
Figure 8: Launch Site Level 1 Object Process Diagram (3/3).....	18
Figure 9: Ground Systems Aggregation	19
Figure 10: Typical Launch Sector for Launches from the Eastern Range.....	25
Figure 11: Aerial view Cape Canaveral Air Force Station in the early 1960's [NASA].....	28
Figure 12: Water Transportation Route for Saturn Boosters	29
Figure 13: KSC (white) and neighboring Cape Canaveral Air Force Station (Green).....	30
Figure 14: Saturn V Launch Vehicle [NASA].....	31
Figure 15: Command/Service Module [NASA]	32
Figure 16: Lunar Module [NASA]	33
Figure 17: Cut-away View of the VAB [NASA].....	34
Figure 18: Apollo Launch Complex 39 [NASA].....	35
Figure 19: Apollo Test and Check-out Flow [NASA].....	35
Figure 20: Safety Zones around LC-39 Complex 39 Pads A-D (1972) [NASA].....	36
Figure 21: Apollo CSM Offline Spacecraft Processing [NASA].....	37
Figure 22: Apollo LM Offline Spacecraft Processing [NASA].....	38
Figure 23: LM Processing in the O&C High Bay [NASA].....	39
Figure 24: Mobile Launcher, Mobile Service Structure and Saturn V on the Pad.....	41
Figure 25: Space Shuttle Rolling from VAB.....	43
Figure 26: KSC Space Shuttle Processing Flow.....	45
Figure 27: Payload Canister Lifted into PCR [NASA].....	47
Figure 28: ISS Flight Hardware Configuration [NASA].....	49
Figure 29: ISS Element Processing Flow [NASA].....	50
Figure 30: MEIT Test Configurations [NASA].....	51
Figure 31: MEIT 2 Underway in the SSPF [NASA].....	52
Figure 32: Orion Crew Exploration Vehicle (CEV) [NASA]	53
Figure 33: Altair Lunar Lander Concept [NASA].....	54
Figure 34 : Constellation Flight Hardware Commonality with Apollo and Shuttle [NASA]	55
Figure 35: Constellation Lunar Mission Profile [NASA].....	56
Figure 36: Ares I/Ground Processing Flow [NASA].....	57
Figure 37: Ares V/Altair GS Flow [NASA]	58
Figure 38: Constellation Ground System Architecture [NASA]	59
Figure 39: Spacecraft Processing Elements [NASA]	60
Figure 40: Ares VAB High-bay Concepts [NASA]	61
Figure 41: Concepts for Constellation Mobile Launchers [NASA]	62
Figure 42: Constellation Ares I Pad [NASA]	63
Figure 43: Command, Control and Communication Element [NASA].....	64
Figure 44: LCS Interfaces [NASA]	64

Figure 45: Ground Systems Interfaces (Block 1 only) [NASA].....	65
Figure 46: Level V Subsystems [NASA].....	67
Figure 47: KSC and CCAFS Land Use (2003) [NASA].....	69
Figure 48: NASA Program Life Cycle	78
Figure 49: NASA Project Life Cycle.....	78
Figure 50: Alternate View of Program/Project Lifecycle.....	79
Figure 51: Astronauts and Ground Ops Crew in ACE Control Room in the O&C [NASA]	84
Figure 52: Early Shuttle Ground Processing Flow Concept.....	89
Figure 53: Early Shuttle Ground Systems Assessment.....	90
Figure 54: One of Two Shuttle Tail Service Masts [NASA].....	93
Figure 55: Space Station Freedom Program [NASA].....	97
Figure 56: Space Station Commonality Program Roles and Responsibilities [NASA]	98
Figure 57: Space Station Program Level Commonality Process [NASA]	99
Figure 58: Support Equipment System Engineering Flow [NASA].....	100
Figure 59: Node 1 in Element Rotation Stand in the SSPF [NASA]	103
Figure 60: Preparing to install Racks with the KSC RID [NASA].....	104
Figure 61: Constellation Work Distribution [NASA].....	106
Figure 62: KSC Engineering Directorate [NASA]	109
Figure 63: Level V Subsystem Integration across Ground System Elements [NASA].....	109
Figure 64: Tilt-up Umbilicals [NASA].....	110
Figure 65: Tilt-Up Umbilical Design Team Structure	111
Figure 66: CPDS GSE [NASA].....	112
Figure 67: Launch Control System - Mission Control System Trade Tree [NASA].....	114
Figure 68: Early Control Center Commonality Risk Benefit Summary [NASA]	114
Figure 69: Launch Control System Subsystem Control and Monitoring [NASA].....	115
Figure 70: LC-39/LC-40 DDTE Cost Comparison [NASA].....	116

This Page Intentionally Left Blank

List of Tables

Table 1: Constellation Ground Systems Element Mapping to System OPD	66
Table 2: Level 5 Subsystems	67
Table 3: Apollo Ground Systems Commonality Summary	87
Table 4: Apollo to Shuttle Ground Systems Re-use	94
Table 5: Space Shuttle Ground Systems Commonality Summary	96
Table 6: ISS Ground Systems Commonality Summary	105
Table 7: Constellation Level 3 Project Summary	107
Table 8: Shuttle to Constellation Ground Systems Re-use	117
Table 9: Constellation Ground Systems Commonality-Summary	118
Table 10: Key Factors for Ground System Commonality	122

This Page Intentionally Left Blank

1 Introduction and Thesis Overview

NASA is once again engaged in a program to develop flight and ground systems to support our Nation's return to the moon and the eventual human exploration of Mars. A key component in the execution of the new program is the effort to minimize near-term development and long-term operations costs. Several approaches are currently employed to achieve these goals including reuse of existing flight hardware and infusing operability into the design of new and modified systems. NASA is also examining the utility of requiring a certain degree of commonality in both flight and ground systems. While the benefits of commonality seem obvious in terms of minimizing upfront development and long-term operations and maintenance costs, success in real, large-scale engineering systems used to support launch operations is relatively unknown. A broad literature review conducted for this paper did not yield a single paper specifically addressing the application of commonality for ground systems at any launch site in the United States or abroad. This paper provides a broad overview of the ground systems, captures historical and current application of commonality at the launch site, and offers suggestions for additional research to further develop commonality approaches.

While the focus of space programs is traditionally the flight hardware such as the Saturn V, Apollo Lunar Module or Space Shuttle Orbiter, ground systems represent a non-trivial development and operations component of space flight programs. As far back as the German V-2 program, the magnitude ground systems were recognized. Dieter Huzel, a close aid to the inventor of the V-2, Werner von Braun, wrote in 1962:

The full meaning and understanding of the fact that in addition to the missile itself, at least as much equipment is also needed to prepare it for flight...¹.

The Space Shuttle System was originally intended to support up to 50 flights per year requiring far fewer ground systems and less effort to operate than traditional launch systems. As the complexity of the flight hardware grew during design and development phases, so did the magnitude of the ground systems. An early concept drawing for ground processing is shown in Figure 1.

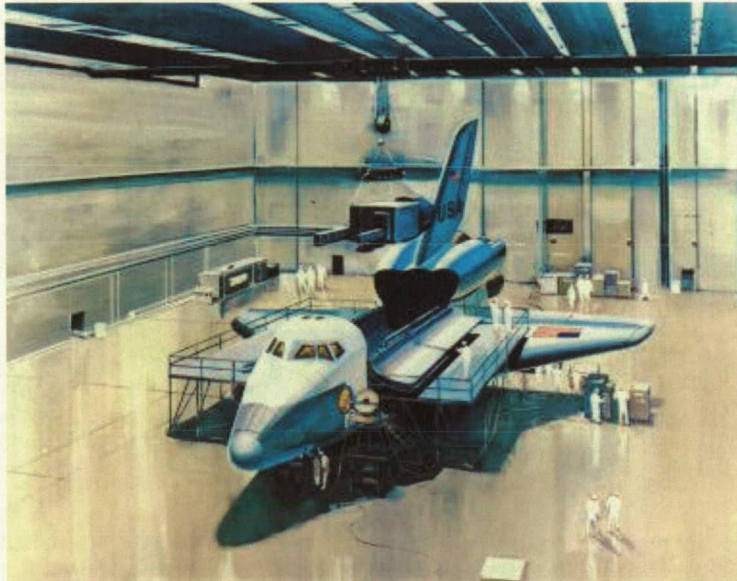

Figure 1: Early Space Shuttle Orbiter Ground Processing Concept [NASA]

A portion of the actual ground systems used to support Orbiter horizontal processing is shown in Figure 2. The Orbiter's nose and Forward Reaction Control System can be seen protruding from ground systems far more complex than originally envisioned by system designers.

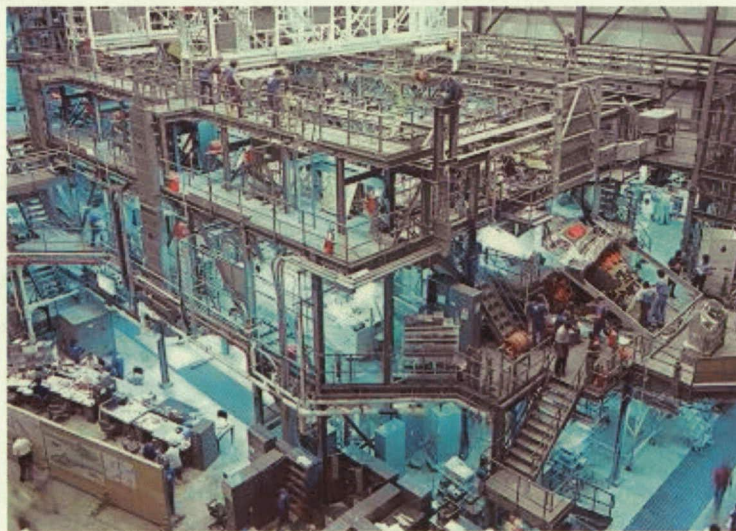

Figure 2: Space Shuttle Orbiter in the Orbiter Processing Facility [NASA]

In Figure 3, Technicians are shown installing interface cables between the Shuttle Mobile Launcher Platform and the Launch Pad. Every one of these cables provides electrical power and/or communications from a ground system.



Figure 3: Interface between Shuttle Mobile Launch Platform and the Launch Pad [NASA]

The development and operation of ground systems at the launch site represent a substantial component of the overall life cycle costs of a space flight program. The relative size of the Constellation Program Ground Operation budget with respect to flight hardware project budgets is shown below in Figure 4. Ground Operations includes development of ground systems and the processing of flight hardware through launch.

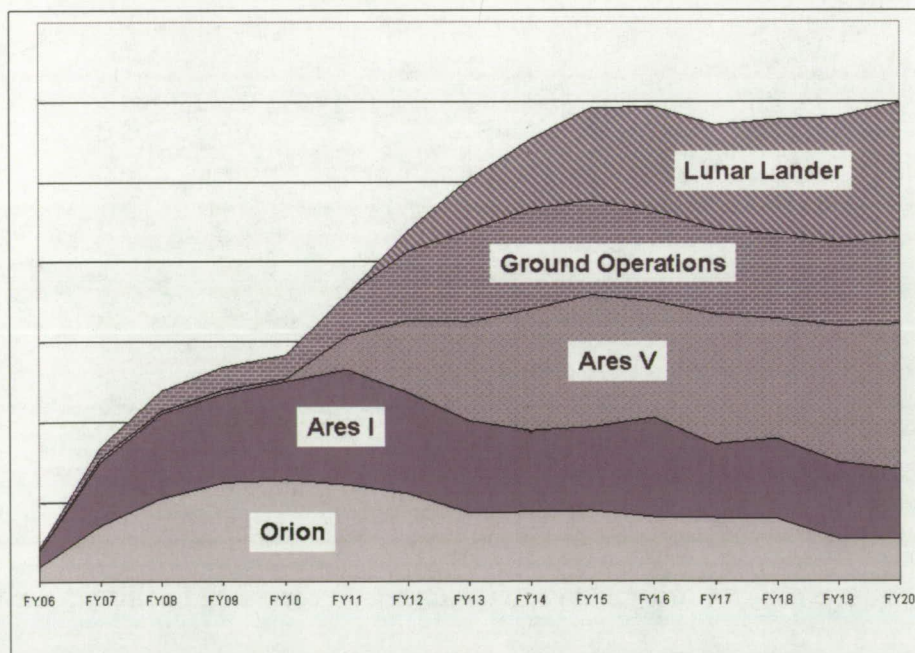

Figure 4: Constellation Projects Budget Comparison

Thesis Overview

This paper serves as a foundation to understand past and current efforts to achieve commonality during the Apollo, Shuttle, Space Station and Constellation Programs at the Kennedy Space Center. By examining commonality in these programs, significant factors affecting the application of commonality can be identified for future efforts. A complete description of the system architecture for a space flight program includes the spacecraft, launch vehicles and ground systems. Current research in the application of commonality in spaceflight programs is focused on flight hardware systems and to some degree, project management. While many readers are familiar with the flight hardware configurations of the Apollo, Space Shuttle, International Space Station and Constellation Programs, most are not familiar with the systems used to support ground processing and launch. Broadly defined, ground systems includes the land, facilities and systems required to support pre-launch, launch operations, landing and recovery operations, flight crew training, missions operations and communication systems. A discussion regarding ground systems commonality requires an understanding of the nature of the work and equipment used at the launch site. Therefore, this paper includes high-level descriptions of the processing concepts and ground systems of the Apollo, Space Shuttle, International Space Station and Constellation Programs.

Chapter 2 begins by defining the terms 'launch site' and 'ground systems' using the Object Process Methodology (OPM) to provide framework to describe the systems used to process and launch the astronaut crew and flight hardware. A historical overview of the Kennedy Space Center (KSC) is provided to capture how the most basic question of where to locate the launch site was determined for the Apollo Program. The generic Object Process Diagram is presented to provide solution neutral description of the launch site. The origin of each program and a description of the flight hardware are provided in order to establish the context required for the more detailed descriptions of the facilities and ground systems used at the Launch Site.

In Chapter 3, a broad literature review is presented outlining current research into commonality. It includes descriptions of applications and methods used to implement commonality and project management challenges associated with the implementation of commonality.

A framework for assessing commonality in ground systems is presented in Chapter 4. The framework addresses development and operational phases of the system. The framework management as well as the levels and types of commonality achieved for each program are presented.

In Chapter 5, the framework presented in Chapter 4 is applied to ground systems used for Apollo, Shuttle, International Space Station Programs and Constellation Programs.

The thesis concludes in Chapter 6 with a summary of key findings from the frame work analysis of the Apollo, Shuttle, ISS and Constellation programs and suggestions for future research.

2 Ground Systems Overview

This chapter provides an overview of ground systems used to support launch operations at the Kennedy Space Center during the Apollo, Shuttle and International Space Station Programs and future ground systems planned to support the new Constellation Program. While the commonality concepts discussed later in this paper apply to many launch sites around the world today, this paper focuses on the infrastructure and ground systems at the Kennedy Space Center. For the remainder of the paper, the terms 'Kennedy Space Center' and 'launch site' will be used interchangeably. The chapter begins by describing the launch site using Object Process Diagrams². The OPDs are intended to provide the reader with a high level understanding of the nature of the work at the launch site prior to describing specific ground systems used in human spaceflight programs at KSC. A brief description of the origins of the U.S. launch capability is included to provide a historical context of the decisions that led to the selection of Cape Canaveral and a large section of Merritt Island for the America's primary launch site. The chapter concludes with high level descriptions of the ground systems used for Apollo, Shuttle, International Space Station and those planned for use in the Constellation Program. This chapter is intended to familiarize the reader with the size and complexity of systems required to process launch vehicles and spacecraft from the four different programs.

2.1 Launch Site Object Process Diagrams (OPD)

The following OPD diagrams provide a high-level solution-neutral description of the launch site and will be used to aid in the description of ground systems at the Kennedy Space Center and how they evolved to support the Apollo, Space Shuttle, ISS and Constellation Programs. The processes describe the nature of work performed at the launch site. The product system boundary between the launch site and relevant external objects is shown in the first OPD diagram below:

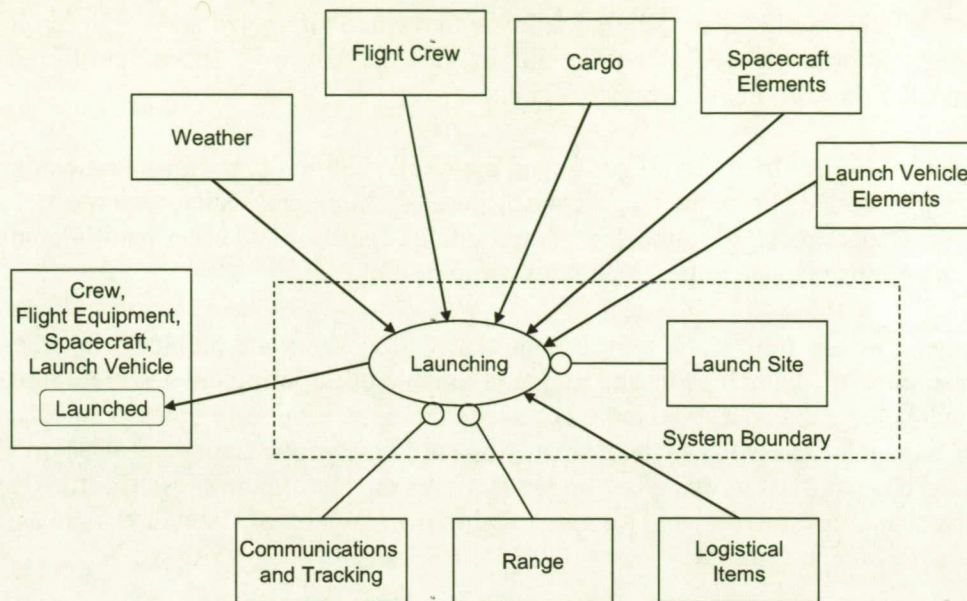

Figure 5: Launch Site Whole System Object Process Diagram

At the highest level, the process 'launching' requires the 'launch site' to yield 'launched' Flight Crew, Flight Equipment, Spacecraft and Launch Vehicle. The objects and processes in the diagram are defined as follows:

Objects

- **Launch Site:** The land and ground systems required to enable the launch of the Crew, Spacecraft, Launch Vehicle and Flight Equipment
- **Flight Crew:** Astronauts to be launched into space
- **Cargo:** Describes flight crew equipment, equipment required to perform science experiments, Orbital Replacement Units for sparing or to replace malfunctioning equipment already on-orbit and in-space logistics items such as food, water, oxygen. Flight Crew Equipment (FCE) includes Extra Vehicular Activity (EVA) Suits, clothing, tools, laptop computers and other equipment intended to fly into space to enable the astronauts to perform their required tasks.
- **Spacecraft Elements:** Flight hardware that is integrated and serviced on the ground, mated to the launch vehicle and enters earth orbit. Examples include the Apollo Command/Service Module, Space Shuttle Orbiter and components of the International Space Station. The origin of the flight hardware may be a manufacturer or refurbishment facility.

- **Launch Vehicle Elements:** Flight hardware that when integrated and serviced on the ground comprise the 'rocket'. Examples include the Saturn V, Space Shuttle and the Constellation Ares-I Crew Launch Vehicle.
- **Logistical Items:** Includes all goods and materials required to perform launching. Examples include propellants, gaseous nitrogen, helium, electricity, water, office supplies, spare parts, gasoline, etc. Traditionally, logistics and other institutional support organizations manage requirements for commodities.
- **Range:** Primary function is to insure the safety of workers and public in the area surrounding the launch pad. The Range is capable of initiating the destruction of the launch vehicle via encrypted radio command from the ground. Typically located at or near a launch head (such as the Kennedy Space Center/Cape Canaveral Air Force Station (CCAFS)). Consists of owned or leased facilities on downrange sites. Controls access to all surrounding land, sea, and air space within the reach of any launch vehicle extending along the launch azimuth.
- **Communications and Tracking (C&T):** Radio Frequency communication such as S-Band, UHF, and Ku-Band. Data, Audio, and Video are transmitted to and from the spacecraft, launch vehicle, and ground.
- **Weather:** The state of the atmosphere at a given time and place, with respect to variables such as temperature, moisture, wind velocity, and barometric pressure³. Weather far from the actual launch site is also a key consideration for the Space Shuttle Program. Space Shuttle Program requires acceptable landing weather for at least one trans- Atlantic abort sites prior to launch. Also includes sea states (wave height, period, ocean temperature, etc.). Sea-states affect the ability to rescue the crew in the event of an abort during ascent.
- **Crew, Flight Equipment, Spacecraft, Launch Vehicle -> Launched:** The primary beneficiary of the process 'launching' is changing the state of the aggregate of flight, crew flight equipment and spacecraft elements and launch vehicle elements to 'Launched'.

Processes

- **Launching:** The process that performs all ground operations required to launch the flight crew, flight equipment, spacecraft elements and launch vehicle elements.

Weather, Workforce, Land and Waterways, and Logistics Items objects affect or are required by all processes. In order to simplify the diagram, sample relationships between these objects and processes are shown in the third OPD. Additionally, there are a multitude of ‘Institutional’ processes that are required to operate and maintain a launch site. They include maintenance of the entire infrastructure (buildings, roads, grounds, etc.), personnel management systems, weather forecasting and reporting, trash removal, etc. These objects and processes are shown for completeness. Institutional processing and related objects within institutional processing will not be addressed in this document. This is not to imply institutional objects and processes are not important. The institutional capabilities of a launch site are often significant factors in determining where to process and launch flight hardware for the next program due to replacement costs for developing a new site.

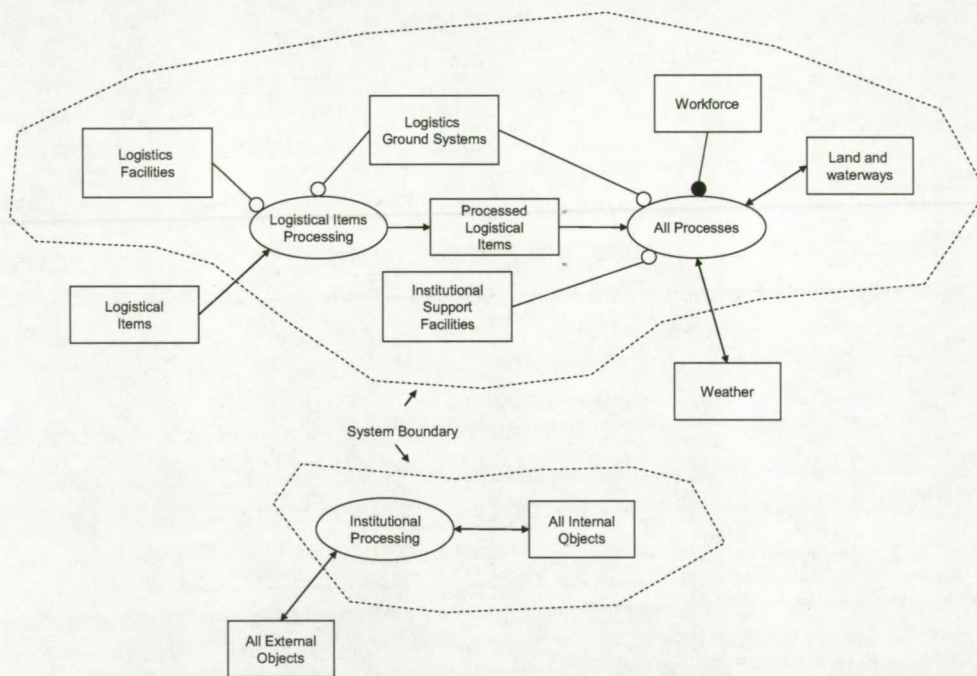

Figure 8: Launch Site Level 1 Object Process Diagram (3/3)

The objects and processes internal to ‘launch site’ and ‘launching’ in the second level OPD diagram are defined as follows:

Internal Launch Site Objects

The description of launch site objects begins by defining a generic Ground Systems object which will be the focus of the commonality assessment in Chapter 5. The definition applies to ground systems supporting launch vehicle and spacecraft processing, integrated operations and launch operations.

Ground Systems typically consists of three internal objects: Facilities, Ground Support Equipment (GSE) and Support Equipment (SE). The aggregation of ground systems is shown in the Figure below.

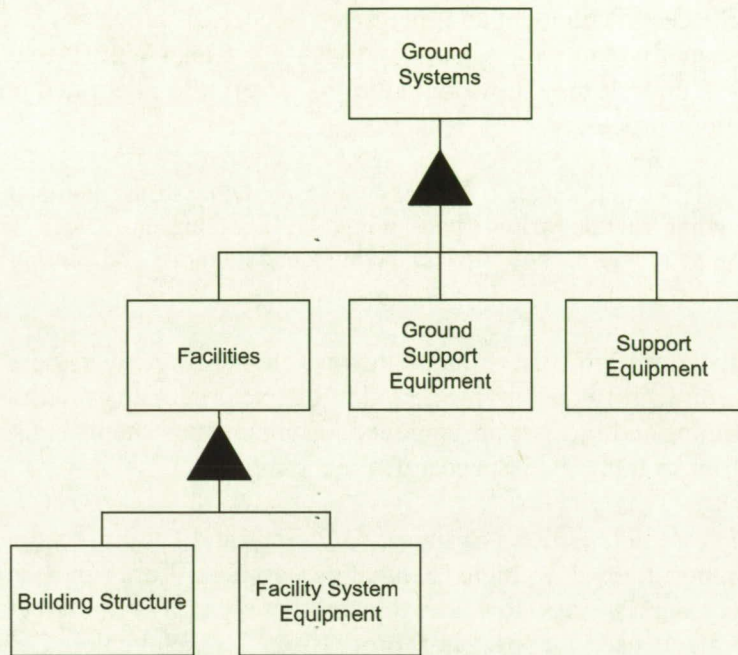

Figure 9: Ground Systems Aggregation

Over the years, the meaning of the term ‘Ground Support Equipment’ evolved to include only systems that directly interfaces physically with the flight hardware such as handling equipment, servicing equipment, test equipment, plugs, covers, etc. The term ‘Support Equipment’ refers to all other hardware at the launch site that does not interface directly to the flight hardware. GSE is often developed and provided by the flight hardware manufacturer while SE is typically developed by the Ground Operations project at KSC. Definitions and examples of all three objects internal to ground systems are described below:

- Facilities: Buildings Structure (walls, floor, roof) and Facility System Equipment (FSE). FSE are integral to the building including overhead bridge cranes, airlocks, heating, ventilation and air conditioning, conditioned power, service interfaces to gaseous helium, nitrogen and other fluids and gases, fire protection, environmental monitoring, closed circuit TV, vacuum cleaning systems, etc.
- Ground Support Equipment: Examples of GSE include special servicing equipment to test and check-out spacecraft subsystems such as avionics, environmental and control and life support, propulsion, electrical power, etc. Mechanical examples include lifting slings, certain types of transporters, special handling equipment, interior access platforms, window covers, etc.

- Support Equipment: Includes command and control systems, work stands, air bearing pallets, mobile environmental control systems, pumps, etc.
- Offline Spacecraft Ground Systems: Buildings and Facility System Equipment (FSE) that support Spacecraft Element and Integrated Spacecraft processing. Offline Spacecraft Facilities are usually required maintain at least 100K Clean Work Areas (CWA). Spacecraft GSE and SE may move with the spacecraft into integrated operations and launch operations processes.

Note: '100K' refers to particulate count per cubic foot. Other forms of contamination are also controlled including volatile hydrocarbons, non-volatile residue, etc. Clean Work Areas also require air positive pressure, controlled temperature and humidity and appropriate monitoring equipment.

- Prepared Spacecraft Elements: Flight hardware elements received from the manufacturer or refurbishment facility that are processed in offline processing facilities. All special shipping restraints and fixtures are removed. Element subsystems are serviced and tested as required prior to Integrated Spacecraft Processing.
- Offline Launch Vehicle Ground Systems: Buildings and Facility System Equipment (FSE) that support Launch Vehicle Element processing. Works areas are required to be Foreign Object Debris free. However, they are not typically required to meet the more CWA requirements used for spacecraft processing. Launch vehicle GSE and SE may move with the spacecraft into integrated operations and launch operations processes.

Note: Damage to, or malfunction of, a launch vehicle or payload caused by any foreign object(s) that are alien to flight systems. FOD may cause material damage or it may make the system or equipment inoperable, unsafe or less efficient. FOD can consist of staples, paper clips, paper, particles generated from operations such as sanding, drilling and welding, liquids and chemicals, food, clothing, lost screws, nuts and washers, tools such as wrenches and screwdrivers, jewelry such as earrings, bracelets, watches and rings, eye glasses, plastic and rubber, tape, string, tie wraps, safety wire. [NASA]

- Prepared Launch Vehicle Elements: Flight hardware elements received from the manufacturer or refurbishment facility that are processed in offline processing facilities. All special shipping restraints and fixtures are removed. Element subsystems are serviced and tested as required prior to Integrated Launch Vehicle/Spacecraft Processing.
- Prepared Cargo: Equipment removed from shipping containers and inspected for shipping damage. Usually involves minimal check-out at the launch site. Each item is specially packed at the launch site and placed into containers unique to spacecraft cargo areas. Prepared Cargo may be stowed in spacecraft processing facilities, integrated operations facilities or while at launch operations facilities. The more time sensitive the cargo, the more likely it will be stowed later in the flow and sometimes just prior to launch. Examples of time sensitive cargo included food and live biological experiments.
- Integrated Spacecraft: Mated flight hardware elements that comprise the spacecraft.

- Integrated Operations Ground Systems: Typically very large buildings and building systems that support stacking of the launch vehicle and mating of the spacecraft to launch vehicle. Examples of GSE and SE include handling equipment such as lifting slings, measurement and leveling and alignment systems, special launch vehicle mating equipment, interim protective, enclosures, tensioning equipment, etc. Integrated Operations GSE and SE may move with the spacecraft into integrated operations and launch operations processes. For KSC, the Shuttle Mobile Launch Platform is an example of GSE that supports stacking operations in the VAB and Launch Operations on the Pad.
- Integrated Spacecraft-Launch Vehicle: Commonly referred to as the 'stack'. Consists of all mated, flight hardware elements.
- Launch Operations Ground Systems: Buildings, structures GSE and SE supporting the final check-out and launch of the Integrated Spacecraft-Launch Vehicle at the Launch Pad. Provides access to flight hardware and limited weather protection (primarily lightning). Includes fluid and gas systems used to service and fuel flight hardware, special test and measurement systems, command and control system components, sound suppression systems, etc.
- Landing and Recovery Operations Ground Systems: Facilities, GSE and SE supporting recovery of spacecraft and launch vehicle elements such as Shuttle SRBs and Shuttle Orbiter. Examples include the Shuttle Landing Facility, and recovery vessels supporting future recovery operations of the Constellation CEV Crew Module.
- Landed Flight Crew: Astronauts returned from on orbit operations.
- Recovered Launch Vehicle Elements: Elements of the launch vehicle recovered following launch for re-use or inspections such as the Shuttle SRBs.
- Recovered Spacecraft Elements: Elements of the Spacecraft recovered following landing such as the Space Shuttle Orbiter and Constellation Crew Exploration Vehicle Crew Module. Recovery operations may occur on land or water.
- Logistics Systems: Buildings and building systems used to process store and distribute flight hardware (ORU level only), ground hardware, and commodities at the launch site. SE includes inventory tracking and control systems, systems, transportation systems (tugs, tractors and specialized transporters).
- Processed Logistical Items: Commodities, goods and materials checked in through launch site shipping and receiving procedures. Components repaired in on-site depot level maintenance facilities.

- Institutional Support Facilities: Buildings and building systems for office and administrative areas, medical, fire and rescue, maintenance, security, on-site labs, public affairs, etc.
- Land and Waterways: Property owned and managed by launch site.
- Workforce: Personnel required for launching. Personnel may or may not be located at the launch site. Consists of government and contractor workers performing the entire range of required tasks from executing launch countdown procedures in the launch control center to removing the trash.
- Prepared Flight Crew: Suited astronauts following final medical checks ready to board spacecraft.

Internal Launch Site Processes

- Offline Cargo Processing: In most cases, this involves simply removing hardware from the shipping container, inspecting it, and repacking into containers unique to spacecraft cargo areas. In some cases, experiment hardware arrives at the launch site in multiple elements and must be assembled and tested prior to stowage in the spacecraft.
- Offline Launch Vehicle Element Processing: Typical processing activities include removal from shipping container, post shipping inspections, placing flight hardware element into work stands, connecting various GSE such as special test equipment, power conditioners, environmental control systems, air monitoring systems and executing test procedures required at this phase of the processing flow. Element interfaces are tested and checked-out.
- Offline Spacecraft Element Processing: Similar to Launch Vehicle Element Processing. Typical processing activities include removal from shipping container, post shipping inspections, placing flight hardware element into work stands, connecting various GSE such as special test equipment, power conditioners, environmental control systems, air monitoring systems and executing test procedures required at this phase of the processing flow. When the element is to be mated to another flight element later in the processing flow or to an element already on orbit, flight emulators are sometimes used to test element interfaces. In some cases, final assembly of a flight vehicle element may occur in this process such as installation of thermal blankets, installing access covers, etc. The Flight Crew will perform support walk-downs and inspections of the spacecraft to ensure the actual flight hardware configuration is consistent with simulators and procedures used during extensive training exercises.
- Integrated Spacecraft Processing: Prepared spacecraft elements are mated to form the complete spacecraft. Interfaces between the spacecraft elements are tested and verified. Additional integrated check-out of spacecraft subsystems may be performed. Final spacecraft closeouts are performed and any necessary purges are established to provide environmental control with spacecraft. The integrated spacecraft is enclosed in a

transportation container and transported to the integrated operations facility. The Flight Crew may also perform support walk-downs and inspections of the spacecraft during this phase to ensure the actual flight hardware configuration is consistent with simulators and procedures used during training exercises.

- **Flight Crew Preparing:** A few months prior to launch, the flight crew will participate in emergency egress training at the launch pad and Terminal Countdown Demonstrations Tests. About three weeks prior to the flight, the astronauts are placed under limited medical quarantine to prevent exposure to communicable diseases. Only authorized personnel are allowed to interact with the astronauts. The quarantine continues following their arrival at the launch site about 3-4 days prior to lift off. Shuttle Astronauts typically arrive at the launch site about 3-4 days prior to launch. While at the launch site, they receive final briefings on the state of the flight hardware, weather and any updates to mission plans. Shuttle pilots and co-pilots also practice approach and landing tests at the Shuttle Landing Facility using the Shuttle Training Aircraft. On the day of launch, the astronaut crews are checked-out one more time by medical personnel, suited up and transferred to launch pad to board the orbiter. During Apollo, astronaut crews arrived at the launch site as much as 90 days prior to launch participated in mission simulations. A Flight Crew Training Building with Lunar Module and Command Module Simulators was located at KSC during Apollo. It was used extensively in the months prior to launch. A terrestrial version of the rover along with a simulated lunar bolder field was used to practice lunar EVAs.
- **Integrated Spacecraft/Launch Vehicle Operations Processing:** Launch Vehicle Elements are transported to the Integrated Operations Facility. Transportation GSE is removed and lifting GSE is attached to allow the flight hardware element to be hoisted and attached to the Mobile Launch Platform (MLP). This continues with additional launch vehicle elements until the vehicle assembly is complete. This process is sometimes referred to as stacking. Once the launch vehicle is stacked, the spacecraft is transported to integrated operations facility and the transportation container is removed. Lifting GSE is attached to the spacecraft and then it is hoisted and mated with the Launch Vehicle. Both vehicles are powered up and a series of integrated tests are performed to verify critical interfaces between the launch vehicle and spacecraft. SE is sometimes attached to the launch vehicle to measure induced loads during transportation. The integrated spacecraft/launch vehicle is then transported to the launch pad.
- **Launch Operating:** Once the integrated spacecraft/launch/MLP vehicle arrives at the launch pad, the MLP is mated to the launch pad. Fluid, gas and electrical interfaces between the launch pad and the MLP are tested and verified. Prior to entering launch countdown, an additional spacecraft and launch vehicle servicing may be performed such as hypergolic fuel and oxidizer loading for reaction control systems; commodity loading; late stowage of time-sensitive science experiments and EVA hardware. Launch countdown begins and final preparations are made to the launch vehicle and spacecraft including arming of pyrotechnic devices; loading of cryogenic propellants; verification of command and data links; ingress of the flight crew; voice communication test, etc. The

countdown terminates with the launch of the spacecraft and crew. Post launch inspections are conducted of ground systems and preparations begin for the next launch.

- **Landing and Recovery Processing:** Includes processes required to support recovery operations launch vehicle elements such as the Shuttle Solid Rocket Boosters; Landing Operations for Shuttle Orbiter; water landing and recovery operations for the Constellation Orion Crew Module. Launch Abort contingency operations are also included in this process.
- **Logistical Items Processing:** Includes logistics engineering, inventory management, government property management, kiting, shipping, receiving and warehousing, transportation and depot level maintenance.
- **Institutional Processing:** Includes administrative and support functions common to very large facilities such as those found on military bases and large manufacturing facilities. Administrative functions include personnel management, human resources development, financial management, procurement, etc. Support functions include: security; fire and rescue; operations and maintenance of the infrastructure (roads, railways, power distribution systems, etc.) and facilities.

2.2 Cape Canaveral

Near the end of the Second World War, many of the German Scientists and Engineers including Werner von Braun, who was responsible for the development of the V-2 missile, continued their work for the American military first in Texas in 1946, then the White Sands Proving Grounds in New Mexico. Cape Canaveral was actually selected by the military to test missile missiles in 1947 primarily due to its location on the south east coast of the United States and the ability to launch over unpopulated regions. Cape Canaveral is located approximately 28.5 degrees north latitude allowing for launch over water at azimuths of 37 degrees and 114 degrees.

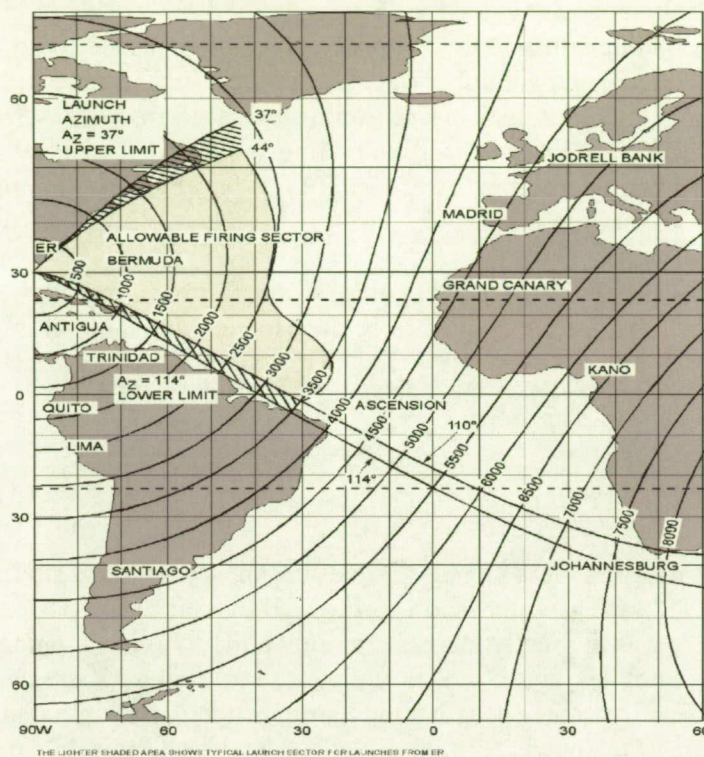

Figure 10: Typical Launch Sector for Launches from the Eastern Range⁴

Note: It is possible to launch into earth orbits from Cape Canaveral at higher or lower azimuths by performing a 'dog leg' maneuver during ascent to avoid populated areas. However, this maneuver consumes additional propellants and lowers a launch vehicle's overall payload to orbit capability significantly.

In the late 1940s, Cape Canaveral was sparsely populated whose most notable feature was the large light house erected in 1847. Launch pads were located within 500 yards of the coast allowing largely experimental rockets to fly over water away from the surrounding communities. In 1950, the Army moved the development team lead by Werner Von Braun to the Redstone Arsenal in northern Alabama. The rocket test program moved to Cape Canaveral, the hub of the newly created Atlantic Missile Range. Early launches included the Bumper 8 and a V-2 with WAC Corporal upper stage on July 23, 1950. Throughout the 1950's, hundreds of intercontinental ballistic missile including the Army's Jupiter and Thor and the Air Force's Atlas Delta and Titan programs were tested and launched from Cape Canaveral⁵.

With the launch of Sputnik on October 4, 1957 the 'Space Race' between the United States and the Soviet Union began. In response, military leaders selected the Navy's Vanguard missile as the primary vehicle to launch America's first satellite. Von Braun's Redstone Program under the Army Ballistic Missile Agency (ABMA) was also given authority to proceed as a back-up to Vanguard. Following the famous Vanguard failure broadcast live on American Television, America's first satellite, Explorer I was finally launched by the Army's Redstone missile from Cape Canaveral on January 31, 1958⁶.

Later in July, President Eisenhower signed the Space Act of 1958 establishing the National and Aeronautics and Space Administration to lead America's civilian space effort. Von Braun's work at the Redstone Arsenal and a number of other organizations involved in related research including the Jet Propulsion Laboratory in California was transferred to NASA as part of an overall effort to focus America's space effort on civilian applications in 1959⁷. However, as Liparito and Butler point out, commonality of technology between military and civilian would require some level of cooperation⁸.

Given the substantial infrastructure already in place to support military missile test programs, Cape Canaveral was the obvious choice to launch the Mercury and Gemini missions. Between May 1961 and 1966, twenty-six astronauts were launched from Mercury-Redstone, Mercury-Atlas and Titan-Gemini launch complexes on Cape Canaveral.

2.3 Apollo

The development of the Saturn class launch vehicles began as a series of studies in April 1957 under the ABMA as the 'Super-Jupiter' and was directed by von Braun's team in Huntsville, AL. The original intent was to greatly increase the capability to existing launch vehicles to orbit large communications satellites, space probes and weather satellites. Keep in mind that the US did not yet successfully orbit a satellite when the Saturn program was initiated. By 1958, through the cooperation of the newly formed Advanced Research Projects Agency (ARPA) and the ABMA, the Juno-V studies were formally funded to determine how to produce a launch vehicle with the capability of 1,500,000 lb. thrust. The development team made substantial progress early and ARPA approved the development of flight hardware leading to plans for three flight tests for a launch vehicle with a cluster of 8 Redstone class engines.

The national uncertainty generated by the launch of Sputnik generated numerous studies and committees all attempting to establish a plan for future American launch vehicles. The "Rosen Report"⁹ submitted to President Eisenhower in January 1959 called for the development three classes of launch vehicles: Atlas/Atlas Centaur; Juno V; and a Nova class launch vehicle with 6 million pounds of thrust at lift-off. The report stated that the Nova class launch vehicle would support manned flights to the lunar surface. Later in the year, the Department of Defense renamed the Juno V Project the Saturn Project. Just a few short months later, the Saturn Project was nearly cancelled by the Department of Defense by those who felt the cost of the large booster was not justified to simply loft a large communications satellite. In June, a report titled Project Horizon included plans for a 12 person military base on the lunar surface by 1965 requiring 64 Saturn launches per year to sustain the crew¹⁰. Negotiations between personnel from NASA, Army and the Air Force agreed to continue the Saturn program under the provisions that it would be transferred to the ABMA and NASA with its own additional funding.

Development of the new class of launch vehicles began with the Redstone derived Saturn I. In 1958, Kurt Debus, a member of von Braun's original V-2 development team, traveled to Cape Canaveral to discuss the requirements for a new launch complex to support the Saturn I test Program. A new site just north of Titan Launch Complex 34 was selected after factoring in the much wider blast safety zones around the pad required by the much larger Saturn I¹¹. Between

1961 and 1968, 4 Saturn-I and 3 Saturn-IBs were launched from Complex 34. It was also the site of tragic Apollo 1 fire that claimed the lives of Virgil Grissom, Edward White and Roger Chaffee in 1967. Following a 21 month stand-down to investigate and implement dozens of technical and procedural issues, the first crewed Apollo mission was launched from Complex 34 on October 11, 1968¹².

With the Saturn-I test program well underway, additional engineering studies continued into 1960 with the development of the Saturn V. The Saturn V was viewed necessary step in the development of the Nova class launch vehicle still viewed as the primary means to achieve a human lunar landing. NASA planners called for an Apollo manned orbiting lab and circumlunar flights between 1968 and 1970. Lunar landings were assumed to occur sometime after 1970¹³. The development of the spacecraft Apollo program was actually initiated by the President Eisenhower in 1960 as a follow-up to the Mercury Program. The original intent of the program was to develop a three man spacecraft that could carry astronauts to low earth orbit and eventually to perform a circumlunar missions¹⁴.

Following the presidential election in 1960, numerous briefings were provided to President John F. Kennedy and his staff regarding the progress of both the civilian and military space programs. After only 4 months after taking office and with the threat of the Soviet Union's perceived technological superiority casting a cloud of fear over the nation, newly elected President John F. Kennedy gave his famous speech to a joint session of congress in 1961:

"...I believe that this nation should commit itself to achieving the goal, before this decade is out, of landing a man on the moon and returning him safely to the earth¹⁵".

It was this speech that established the Apollo Program as a national priority, provided the impetus for bipartisan support for funding and set the deadline for the first human mission to the surface of the moon to be completed by 1969.

By May of 1961, the Saturn V and Apollo spacecraft were still just concepts on paper and the trade studies for the ground systems required to support process and launch were just starting. A variety of launch vehicle configurations continued to be studied well in the 1962. In July, NASA settled on the Saturn V over Nova following the decision to use the lunar-orbit-rendezvous over other methods for reaching the lunar surface and returning to earth.

Studies were initiated to answer the most basic question: Where to locate Apollo-Saturn V Launch Complex? While Cape Canaveral seemed the obvious location to build the massive infrastructure required to support the moon program, there were concerns about larger blast radius and the launch danger areas required for the Saturn V. Additionally, by the early 1960's, the DOD's missile test program had already used much of the space on Cape Canaveral.



Figure 11: Aerial view Cape Canaveral Air Force Station in the early 1960's [NASA]

Planning for the infrastructure and systems at the launch site was led by Kurt Debus, the director of the Launch Operations Directorate (LOD). At the time, the LOD still reported directly to von Braun's team at the Marshall Space Flight Center in Huntsville, AL. In 1961, a House Committee "Report on Cape Canaveral Inspection" observed that available space for new launch complexes was limited. During this period, the DOD continued to be heavily involved in the lunar program. Numerous agreements existed between NASA and DOD since the formation of NASA that included the use of the range at Cape Canaveral¹⁶. While overall operations of the spaceflight program were clearly a NASA responsibility, all launch facilities and systems used to date were located on Air Force property. Additionally, the Air Force owned all Range assets including sophisticated tracking and communication equipment on-site and further down range as far as Ascension Island in the South Atlantic.

A joint NASA-Air Force study was initiated by Debus and Air Force General Leighton Davis to determine where to launch the Saturn V. Many of the factors driving the decision as to where to locate the new Launch Complex were safety related. The Joint NASA-Air Force Hazards Analysis Board examined the effects of Blast, Noise, fire, fragmentation, radiation and toxicity¹⁷. At the time, both Saturn and Nova class launch vehicles were still under consideration. Additionally, NASA and the Atomic Energy Committee were pursuing nuclear powered upper stages for space applications¹⁸. Therefore, safety zones around the launch pad were established for both vehicles as well as potential nuclear powered upper stages.

In early 1960s, an off-shore launch complex for both Saturn and Nova programs was studied that intended to leverage off the same technology used in off-shore oil rigs. The approach allowed the launch complexes to be located far away from population centers eliminating the public safety hazards. Additionally, due to the size of the Saturn and Nova first stages, water transport was the only method available to ship the stages from the manufacturing facility to the launch site¹⁹. The committee studied seven land bases sites and one off shore site: Cape Canaveral

(would require the acquisition of additional land adjacent to Cape Canaveral), Offshore from Cape Canaveral; Mayaguana Island in the Bahamas; Cumberland Island, Georgia area near Brownsville, Texas; White Sands Missiles Range in New Mexico; Christmas Island in the South Pacific; and South Point on the island of Hawaii. The island sites in the Bahamas, South Pacific and Hawaii were rejected on the basis of expected high costs of development and operations. Since White Sands was located in the middle of New Mexico, booster transportation via sea thought to be required via waterways was not possible. Vehicles launch from the Texas site would fly over large population centers and thus was rejected as well. While Cumberland Island, Georgia met all technical criteria, expensive new tracking equipment was going to have to be built downrange.

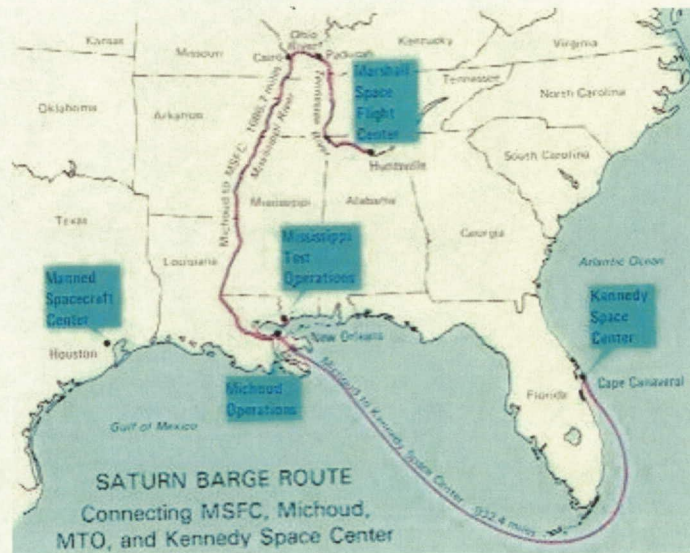

Figure 12: Water Transportation Route for Saturn Boosters²⁰

Ultimately, Cape Canaveral was selected over Cumberland Island largely due to the cost of additional range assets²¹. Between 1962 and 1964, four separate tracts of land on the northern half of Merritt Island to the west and north of Cape Canaveral were purchased by the Army Corps of Engineers²² and NASA²³. The land, facilities and ground systems built on it to support the lunar program would later become the Launch Operations Center led by Center Director Kurt Debus, reporting directly to NASA Headquarters in Washington D.C. and independent of the Marshall Space Flight Center. In November, 1963 it was renamed the John F. Kennedy Space Center in honor of the slain president.

It is important to point out that the Air Force retained ownership of all of the original launch complexes, range assets and land on Cape Canaveral. In 1964, the Air Force renamed the Atlantic Missile Range the Cape Canaveral Air Force Station (CCAFS). To be precise, the 'Cape' is the CCAFS.

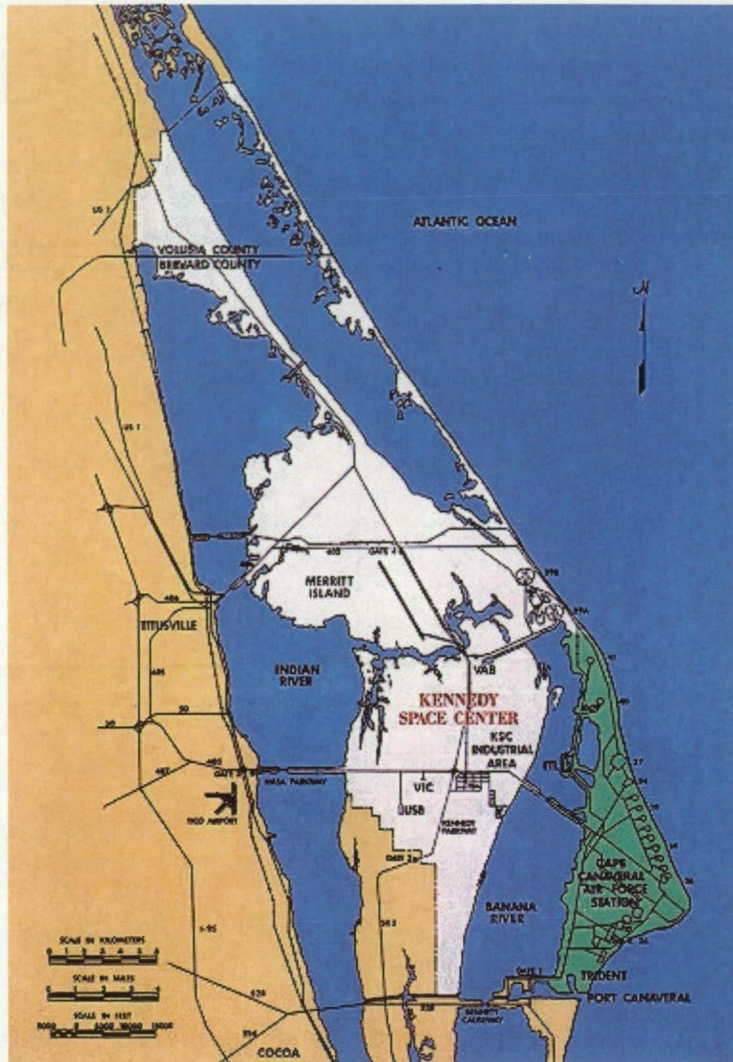

Figure 13: KSC (white) and neighboring Cape Canaveral Air Force Station (Green)

Flight Hardware

Werner von Braun “preached and practiced that rocket and launch pad must be mated on the drawing board, if they were to be compatible at the launching²⁴”. The flight hardware configurations are the primary drivers for requirements for facilities and ground systems. A brief description of the Saturn V Launch vehicle, Apollo Spacecraft, and high-level ground concept of operations is described in order to provide context for more detailed descriptions of facilities and ground systems developed for Apollo Program.

The Saturn V launch vehicle consists of three stages and the Instrument Unit. Additional details included size, weight, thrust and propellant types are shown in the following drawings.

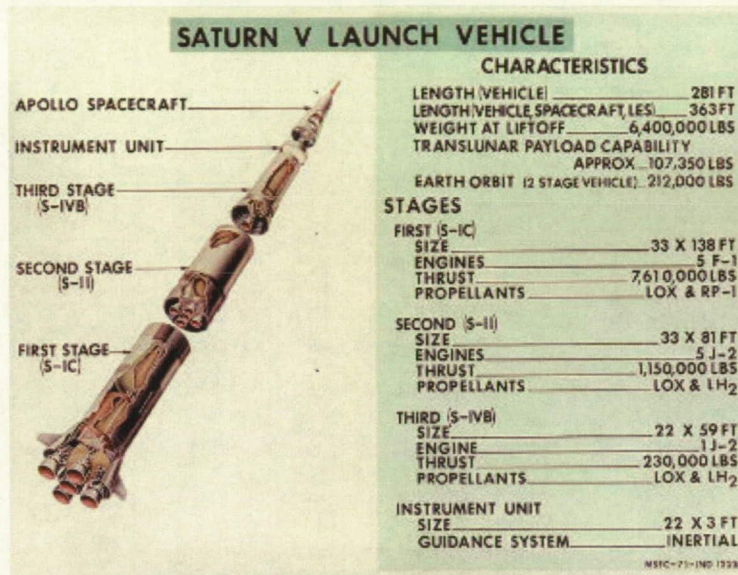

Figure 14: Saturn V Launch Vehicle [NASA]

The Saturn V is the largest launch vehicle built to date both in terms physical size and payload lift capability.

The Apollo spacecraft consisted of five major assemblies: the Command Module (CM), the Service Module (SM), the Lunar Module (LM), the Spacecraft/Lunar Module Adapter (SLA), and the Launch Escape System (LES). The CM housed the three person astronaut crew in during ascent, operations in low earth orbit, lunar orbit and re-entry. The Service Module contained the hypergolic propulsion systems used for the lunar orbit insertion, trans-earth injection, commodities such as oxygen for breathing air and the fuel cells, and SM hypergolic reaction control system.

Note: Hypergolic propulsion systems are very reliable and relatively simple compared to other systems that require igniters. However, the propellants used in hypergolic systems are extremely toxic and require special handling procedures and facilities.

The Launch Escape System provided the means to separate the CM from the remainder of the Apollo-Saturn stack in the event of catastrophic emergency on the launch pad or during the atmospheric phase of ascent. The LES was jettisoned about three minutes after liftoff at an altitude of 60 miles. The Space Craft Launch Adapter protected the Lunar Module during ascent and provided structural support between the CM/SM and Saturn V SIVB stage. The mated CM/SM (or CSM) was just over 36 feet tall and had a total dry weight of about 66.9 thousand pounds.

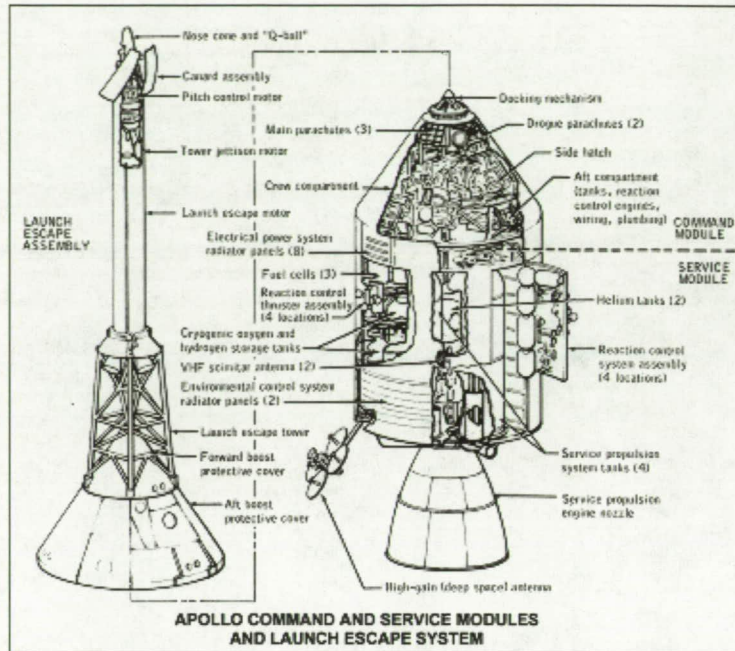

Figure 15: Command/Service Module [NASA]

The Lunar Module consists of two elements including the Descent Stage and Ascent Stage and was 22 feet tall by 31 feet wide. The Ascent Stage and Descent stage were mated together with 4 explosive bolts and had a combined dry weight of about 32 thousand pounds. The Descent Stage consists of a single engine hypergolic propulsion system, landing gear and modularized equipment bay used to store science equipment for experiments to be conducted on the lunar surface. The Descent Stage was also used as a launch platform for the Ascent Stage following lunar surface operations lasting on 1-3 days. The Ascent Stage was an irregularly shaped element approximately 9 feet high and 13 by 14 feet and had a total habitable volume of 235 cubic feet for an astronaut crew of two. Subsystems within the Ascent Stage include the reaction control system, three antennas systems, environmental control systems, avionics and the docking systems.

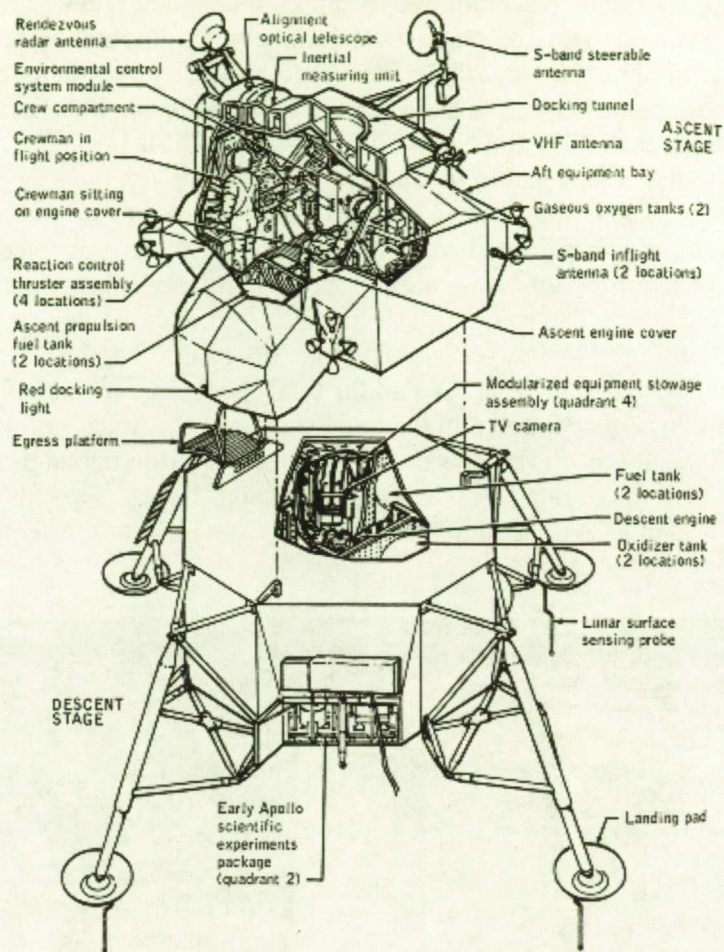

Figure 16: Lunar Module [NASA]

In addition to the launch vehicle and spacecraft elements, lunar rovers and a variety of scientific equipment were also processed stowed for flight on the Lunar Module Descent Stage at the Kennedy Space Center prior to launch. Examples of the scientific experiments include the Passive Lunar Seismic Experiment, Medium-Energy Solar Wind experiment, Active Lunar Seismic Experiment, Heat Flow Experiment and the Laser Ranging Retroreflector. The equipment used for these experiments contained in the Apollo Lunar Surface Experiments Package (ALSEP) powered by a radioisotope thermoelectric generator (RTG)²⁵.

Ground Operations Concept

Numerous trade studies were conducted to determine the best ground operation concept for processing the Apollo spacecraft and Saturn V launch vehicle. Significant factors driving the trades were the physical size of the launch vehicle and spacecraft elements, the desired launch rate and the amount of on-board propellants that contributed to large safety zones required around the launch pads. As many as 100 Saturn flights per year were considered as late as 1960. The existing approach for erecting the launch vehicle on the pad would not support the projected

launch rate. Building additional pads required to support the launch rate was ruled out due to construction, operations, and maintenance costs. Ultimately, the 'mobile launch' concept was chosen for the Saturn V. The primary architecture difference between the mobile launch concept and existing ground operations concepts at the time was where to stack the launch vehicle and spacecraft. Through out the 1950s and early 1960s, elements of all US launch vehicles were transported directly to the launch pad to be stacked. Integration with the spacecraft also took place at the launch pad. The mobile launch concept called for the construction of a very large Saturn integration building where launch vehicle elements would be processed and integrated far enough away from the overpressure zones around the pad. Spacecraft processing would occur near the integration building. The spacecraft would be mated with the launch vehicle inside the Saturn Integration Building. The integrated stack consisting of both the Saturn and Apollo Spacecraft would then be transported to the Pad for final checkout and launch. There were several advantages to this concept noted in the trade studies at the time: minimize loss to infrastructure and adjacent launch vehicles on near by pads, environmental protection again the salt air environment near the ocean, and hurricane protection.²⁶ Key elements of the mobile launch complex such as the VAB, Mobile Launcher and Crawler Transporter are shown in Figures 17 and 18.

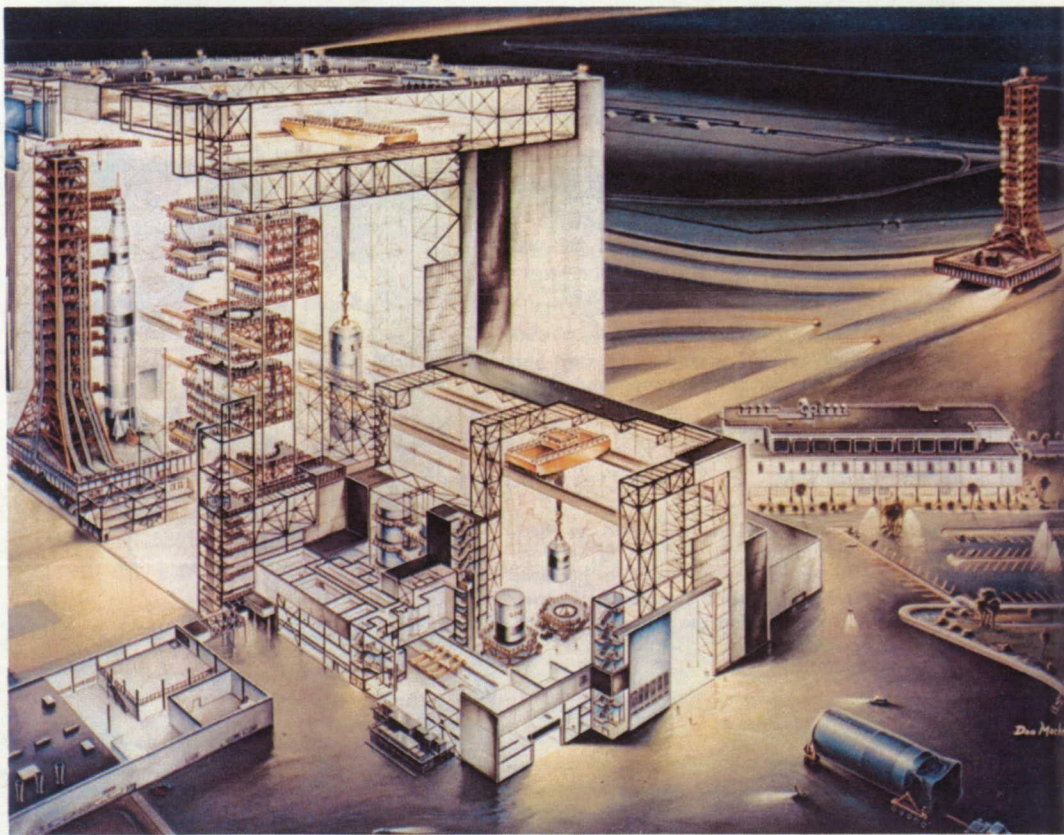

Figure 17: Cut-away View of the VAB [NASA]

LAUNCH COMPLEX 39

794-1823

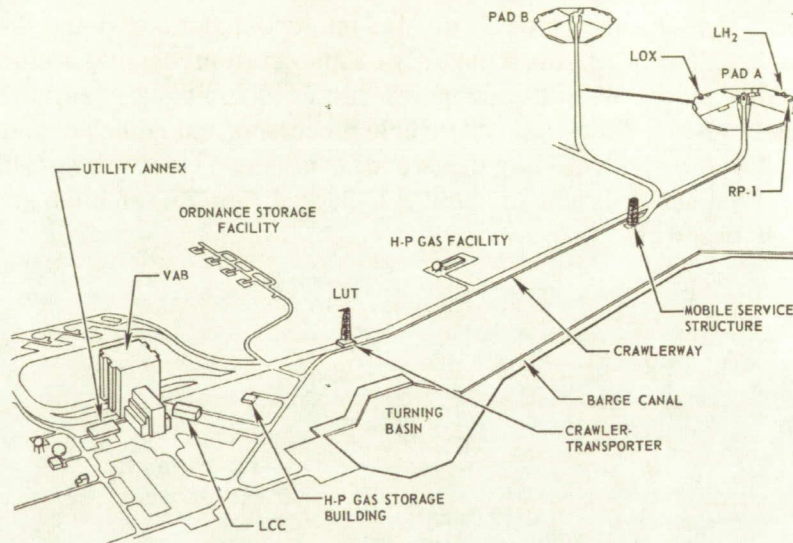

Figure 18: Apollo Launch Complex 39 [NASA]

Test and check-out flow of the Apollo-Saturn Vehicle consisted of over 450 tests. Operational procedures conducted for Apollo 4 included were divided into nine categories: electrical networks (90); measuring, fire detection, etc. (49); telemetry (27); RF and tracking (21); gyroscopes, navigation, control, and ground operations computers (86); mechanical and propulsion (146); combined systems (9); launch support equipment (13); and space vehicle (15)²⁷. The check-out procedure is shown below Figure 19.

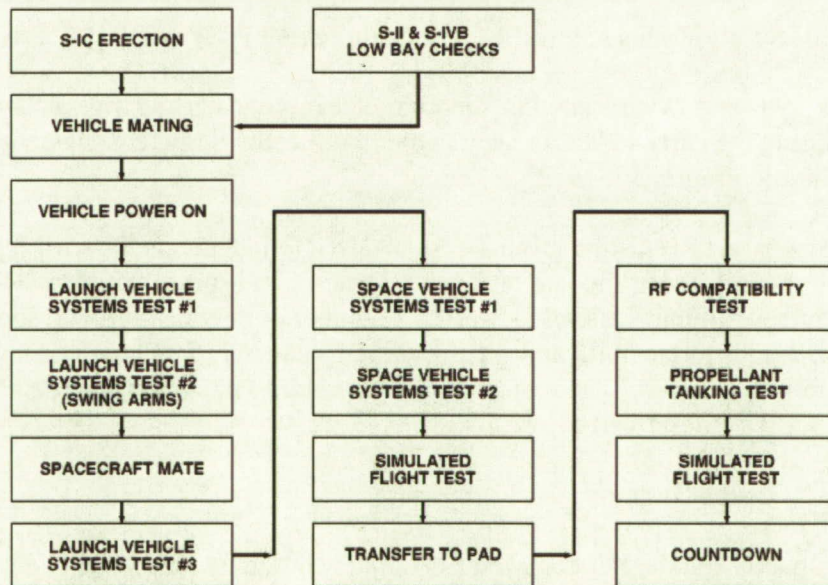

Figure 19: Apollo Test and Check-out Flow [NASA]

Apollo Ground Systems

The Kennedy Space Center can be roughly divided into two major areas: the 'Industrial Area' and Launch Complex 39. For Apollo, a majority of spacecraft processing occurred in the Industrial Area. Many of the institution support facilities including large office buildings were also located in the Industrial Area. Launch vehicle processing and launch operations occurred at Launch Complex 39. A map identifying the two areas is shown below along with the blast radii around the Saturn V launch pads actually built (LC-39 Pad A and B) and two proposed Saturn V launch pads (LC-39 C and D).

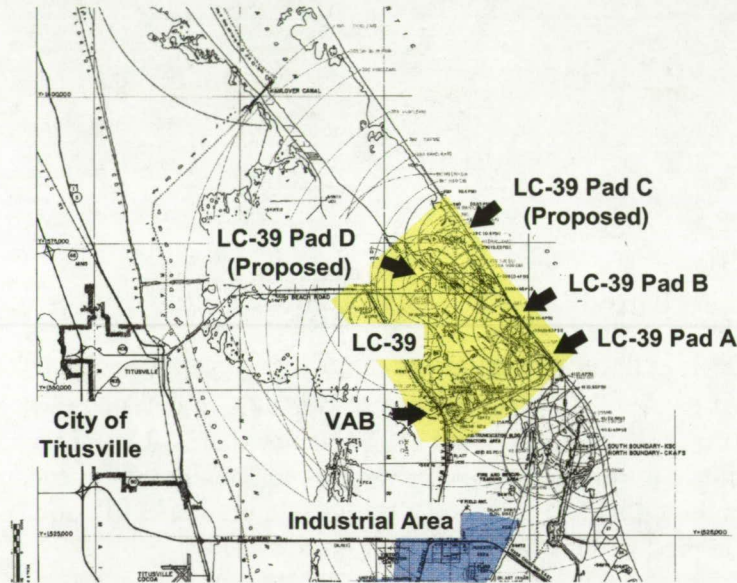

Figure 20: Safety Zones around LC-39 Complex 39 Pads A-D (1972) [NASA]

Launch Complex 39 C and D were sited to support nuclear payloads and higher Saturn V launch rates proposed during the early 1960s and were never built following the decision to proceed with the Space Shuttle Program in 1972.

As discussed previously, the existing ground systems used to launch the Saturn 1 and 1B launch vehicles could not readily accommodate the launch vehicles and spacecraft planned for the lunar landings. Entirely new ground systems as well as a number of new institutional support facilities were developed on lands to the north and west of Cape Canaveral to process and launch the Saturn V and Apollo spacecraft. The more significant ground systems support facilities developed for Apollo are described below.

Offline Spacecraft Ground Systems

The Apollo Command Module, Service Module, Lunar Module Ascent Stage and Lunar Module Descent Stage arrived at the CCAFS skidstrip (runway) via separate flights on-board the Pregnant Guppy, a modified Boeing 377 Stratocruiser. Each spacecraft element was transported to the Operations and Checkout (O&C) building for offline spacecraft processing. Initially, the

Apollo spacecraft were planned to arrive at KSC in a flight ready condition and very little testing was planned at KSC. However, as spacecraft development fell behind schedule, spacecraft were shipped to KSC with open work from the manufacturing facility. Unplanned testing had to be conducted at KSC requiring far more ground systems than originally planned. Significant tests performed on the spacecraft during offline operations included the following: Altitude chamber testing in for CSM and Lunar Module Ascent Stage; CSM/LM docking tests; Several simulated manned altitude runs were accomplished with the prime and back up crews in the Command Module and Lunar Module Ascent Stage; Communication System Tests; and Fuel Cell installation and G&NC Test. Offline processing flows for the CSM and Lunar Module are shown below.

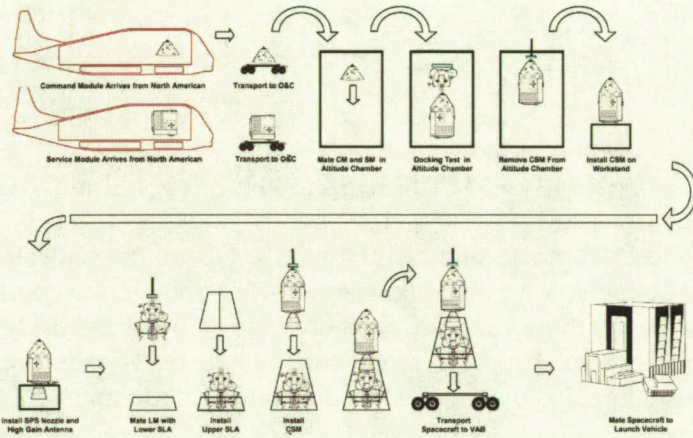

Figure 21: Apollo CSM Offline Spacecraft Processing [NASA]

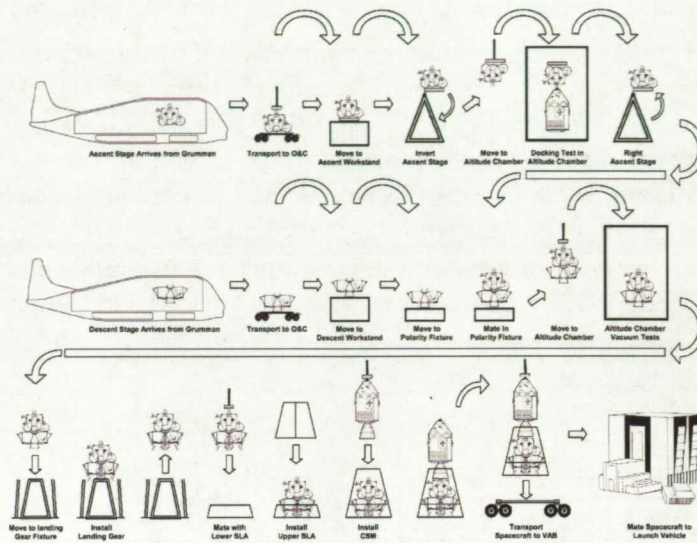

Figure 22: Apollo LM Offline Spacecraft Processing [NASA]

The primary offline spacecraft processing facility was the Operations and Check-out Building. The building included administrative and engineering office area, living quarters for the astronauts, a high-bay area with two altitude chambers and an overhead bridge crane. Other facilities built to support offline spacecraft processing include the Hypergolic Test Building, Weight and Balance Building, Cryogenic Test Building and Environmental Control Systems Building.

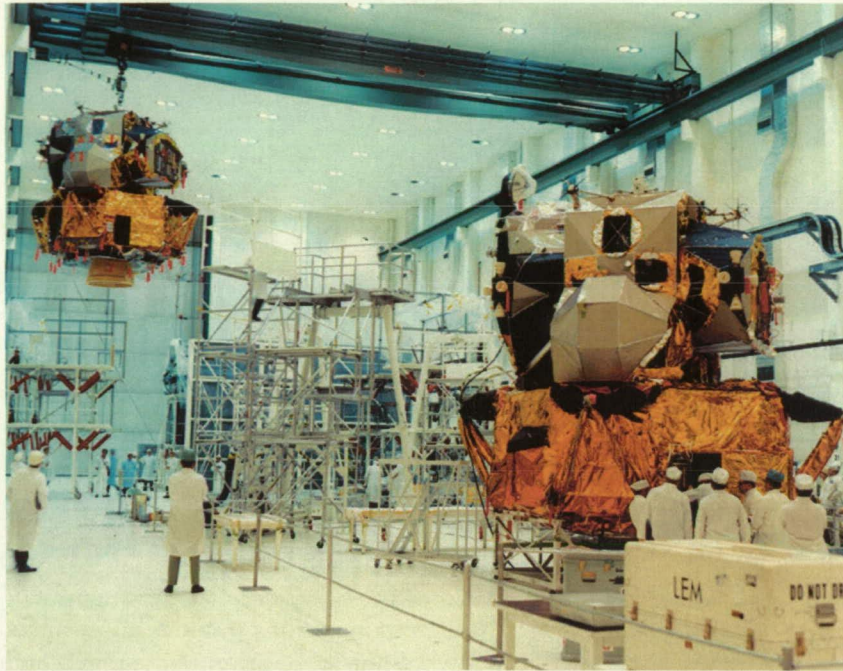

Figure 23: LM Processing in the O&C High Bay [NASA]

Ground Support Equipment for the Apollo spacecraft included hundreds of items ranging from simple window covers to complex GN&C check-out systems. Examples of GSE for the CSM and Lunar Module include Fuel Cell and Cryogenic Storage Subsystem Heater and Power Supply; Pyrotechnics Initiator Substitute Units; Antenna Checkout Set; Fuel and Oxidizer Transfer Conditioning Units, Lunar Module Rendezvous Radar Test Equipment and Water Glycol Servicing Units²⁸. The command and control system used for off-line spacecraft processing was the Automate Check-out Equipment (ACE).

Offline Launch Vehicle Ground Systems

Launch vehicle elements arrived via the barge and the Turning Basin located near the Vehicle Assembly Building and was transported into the VAB Low Bay. Offline check-out of the S-IC, S-II and S-IVB occurred in the VAB Low Bays and transfer aisle. Numerous types of GSE were used to check-out avionics, fluid systems, electrical power systems, etc.

Integrated Operations Ground Systems

VAB: The VAB was a key element of the mobile launch concept and used to stack and integrate the Saturn V and Apollo Spacecraft. At the time of construction, the VAB was the largest building in the world by volume. Characteristics of the VAB are as follows:

- Area: VAB covers 8 acres
- Height: 525 ft
- Length: 158 meters

- Width: 518 ft wide
 - Volume: 129,428,000 cubic feet
 - Steel: 98,590 tons
 - Concrete: 65,000 cubic yards
 - Piling: 4,225 open-end steel pipe piles driven 160 ft into bedrock.
 - Air Conditioning: 10,000 tons with 125 ventilators.
 - Lifting Devices: 71 cranes including two 250 ton) bridge cranes
 - Four High Bay doors 456 ft. high²⁹
- Launch Control Center (LCC): The LCC contained four firing rooms (only 3 were equipped) to house the 450+ member Saturn launch team and the command and control system. The command and control system was based on RCA 110A computers to support 400 consoles. Computers were housed in the LCC and in the Mobile Launcher.
 - Mobile Launcher (ML): The ML was a very large steel structure consisting of a Mobile Launcher Base and Launch Umbilical Tower. The ML was also key component of the mobile launch concept and was used to support stacking operations in the VAB, transportation to the pad and launch operations. Interfaces to the vehicle were provided via nine swing arms and four hold-down arms. The swing arms provided access and service to the vehicle such as fluid and gases (kerosene, LOX/Hydrogen, helium, nitrogen, etc.); ground power communications and data.
 - Mobile Service Structure (MSS): Originally conceived as an arming tower, the MSS evolved to support late vehicle access requirements at the pad following roll-out..
 - Crawler Transporter: The third key element of the mobile launch concept is the Crawler Transporter. Following trade studies that examine rail and barge options to transport the Mobile Launcher and Saturn V to the Pad, ground system developers selected a tracked vehicle concept based on large steam shovels used to mine surface coal. The Crawler Transporter consists of 8 steel tracks driven by 16 electric motors. Electric power is provided by four 1,000 kw generators, driven by two 2,750hp diesel engines. There are also two 750 kw generators powered by two 1,065 hp diesel engines used for jacking, steering, lighting, and ventilating.³⁰ Two Crawler Transporters were built on site for Apollo.

Launch Operations Ground Systems

- Launch Pads: The two Saturn launch pads consist of a concrete base; flame trench; liquid hydrogen, liquid oxygen and kerosene fueling systems; and a steel flame deflector. Each of the two Saturn V Launch Pads was constructed with over 68,000 cubic yards of concrete. The ramp leading up to the pad is inclined at a 5% grade and the flame trench is 42 ft deep; 450ft long and 58 ft wide³¹.

A Mobil Launcher, Mobile Service Structure and Saturn V are shown on the Pad below in Figure 24.

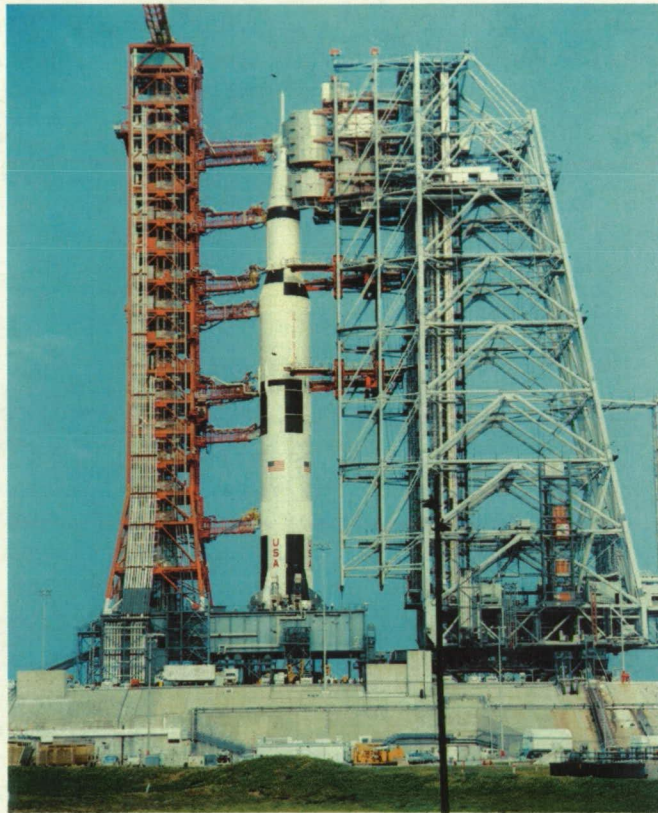

Figure 24: Mobile Launcher, Mobile Service Structure and Saturn V on the Pad

2.4 Space Shuttle

As early as the 1965, four years prior to the first Apollo lunar landing, NASA administrator James Webb formed the 'Future Programs Task Group' to begin planning for missions following Apollo. The report described continued exploration of the moon beyond what was already planned for Apollo, orbiting space stations and manned exploration of Mars leveraging off the substantial capabilities provided by the Saturn launch vehicle family and Apollo spacecraft³². Later, in 1969, the Space Task Group established by President Nixon called for development of new capabilities for operating in space at substantially lower costs. The recommendations included in the report eventually led to the abandonment of the Saturn launch vehicles and Apollo spacecraft following the Skylab and Apollo-Soyuz Test Program. On January 5, 1970 President Nixon approved the Space Transportation System more commonly referred to as the Space Shuttle.

Given the sensitivity for cost, it would seem the reuse of ground systems would make KSC an obvious choice for supporting both launch and landing operations for the Space Shuttle. Following the program's approval, however, over 40 states and 150 sites, including New Mexico, Texas, Utah and Oklahoma, lobbied to be selected as the launch and landing site for the Shuttle. The selection of the Solid Rocket Boosters over liquid fly-back booster variants limited

the feasible candidate sites to coastal areas. Vandenberg Air Force Base (AFB) was selected for Shuttle Missions requiring polar orbits. Costs of new facilities, regional environmental impacts including sonic booms rocket exhaust and workforce issues were all factors considered during the evaluations. Screening to meet major mission and site requirements resulted in two final candidate options: Matagoraa, Texas and existing east/west coastal sites - KSC and Vandenberg AFB. Due largely to the same factors that led to the selection of KSC for Apollo-Saturn V launches such as flexibility with launch azimuths, the ability to launch directly over water and the existing infrastructure led to the selection of KSC for Shuttle launch and landing operations on April 14, 1972³³.

Flight Hardware Configuration

The Space Shuttle consists of three major flight hardware elements: the Orbiter; External Tank (ET); and Solid Rocket Boosters (SRBs). The Space Shuttle can carry a crew of up to seven astronauts and deliver payloads weighing up to 55,000 pounds to low earth orbit. The Orbiter and Solid Rocket Boosters (SRBs) are re-usable. Each Orbiter is approximately 122 ft in length; has a wing span of 78 ft and is 58 ft tall. The Orbiter weighs approximately 240,000 pounds at liftoff has a payload bay 15 ft wide by 60 feet long. The Orbiter propulsion system consists of three LOX/Hydrogen Space Shuttle Main Engines and two hypergolic Orbiter Maneuvering System (OMS) Engines. Hypergolic reaction control thrusters are contained in the Forward Reaction Control System and in the two OMS Pods. The Orbiter thermal protection systems consist of over 30,000 unique ceramic tiles, thermal blankets, and reinforced carbon-carbon panels located on the nose and leading edge of the wings. Each SRB consists of a reusable four segment solid rocket motor; Aft Skirt; Forward Skirt; and Frustum. Each SRB weighs 1,300,000 pounds at launch and provides 3,300,000 pounds of thrust at launch. The SRBs are jettisoned at about 220,000 feet and are recovered 120 miles down range from KSC. The ET is about 158 feet tall and 27 feet wide. The ET is loaded with 143,000 gallons LOX and 385,000 gallons of Liquid Hydrogen at launch. LOX and Hydrogen is supplied to the Orbiter Main Engines via two 17 inch wide feed lines. The ET is jettisoned approximately eight and a half minutes into flight and impacts the Indian or Pacific Oceans depending on the launch azimuth. They are not re-used. The Space Shuttle System is shown in Figure 25:



Figure 25: Space Shuttle Rolling from VAB

Ground Operations Concept

The Shuttle was the first launch system designed to be reused. All Space Shuttle elements are processed, launched and refurbished at KSC.

KSC Ground Processing begins immediately after landing at the Shuttle Landing Facility (SLF) at KSC or Edwards Air Force Base in California. Ground operations personnel dressed in protective equipment and breathing gear verify no hazardous vapors are present following landing. The flight crew egresses the Orbiter and final vehicle safing operations are performed prior to rolling the vehicle to the Orbiter Processing Facility (for KSC landings) or the Mate/Dem-mate device for California Landings. For California Landings, the Orbiter is mated to a specially modified 747 and returned to KSC via the SLF. Inside the Orbiter Processing Facility, the OMS and RCS pods are removed and taken to the Hypergolic Maintenance Facility for servicing. Space Shuttle Main engines are removed and taken to the Main Engine shop for inspections and servicing. Dozens of other systems are serviced including: Electrical Power Distribution; Electrical Power Generation; Lighting; Life Support Systems; Thermal Protection; Data Processing Systems; Guidance, Navigation, and Control; Main Propulsion

APU/Hydraulics; Landing Gear; Mechanical Systems; Docking System; Communications Systems; Instrumentation; Escape/Crew Systems; Structures; Displays and Controls; and Remote Manipulator System. The Orbiter is then rolled over to the VAB for stacking.

The ETs arrive at the Turning Basin via barge from the Michoud Assembly Facility in Louisiana and are transported to ET check-out cells in the VAB for inspections. SRBs are recovered by two specially design retrieval ships about 120 mile down range from KSC. They are brought back to Hanger AF (located on CCAFS), inspected, disassembled and cleaned (removing all residual solid rocket propellant). Solid Rocket Motor Segments are transported back to Utah where they are refurbished and re-loaded with propellant. The Aft Skirts, Forward Skirts and Frustums are transported to the Assembly and Refurbishment Facility where they are prepared for a future flight. Since 1998, most Space Shuttle Missions support construction and operations of the International Space Station. Therefore, most payloads are processed in the Space Station Processing Facility (see next section). The Elements are transported to the Launch Pad where they are installed in the Orbiter's Payload bay via the Payload Change-out Room on the Launch Pad.

Integrated Operations begins once the SRB stacking operations are complete on the Mobil Launch Platform in the VAB. The ET is removed from the check-out cell and mated to the SRBs. The Orbiter rolls over from the Orbiter Processing Facility and Mated to the External Tank. Integrated tests are performed within a week and the Space Shuttle Stack is rolled to the Pad via the Crawler Transporter for final checkout and launch.

The entire Shuttle processing flow is shown in Figure 26:

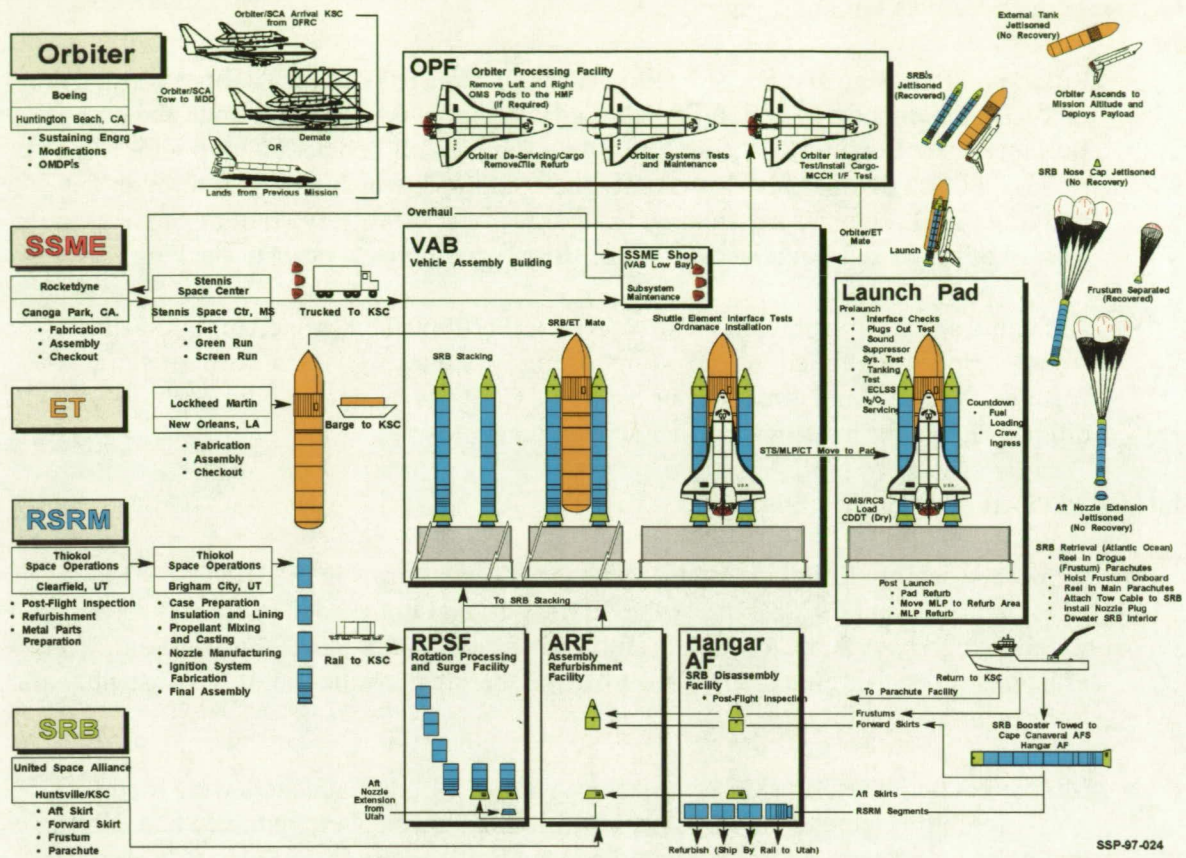

Figure 26: KSC Space Shuttle Processing Flow

Ground Systems

Offline Spacecraft Ground Systems

- Orbiter Processing Facility: The OPF consists of three hanger-like processing bays. Each processing bay contains access platforms which surround the orbiter and allow interior access; environmental, emergency exhaust and fire protection systems; fixed cranes; a zero-G counterweight device for payload bay door operations; Launch Processing System (LPS) computerized checkout interface equipment with the Launch Control Center (LCC); shops; material service center; and mechanical and electrical support equipment.
- Hypergolic Maintenance Facility (HMF): The HMF contains test cells equipped with cranes; access platforms; emergency exhaust and fire protection systems; and a small Launch Processing Systems set for the test, maintenance, modification and repair of orbiter hypergolic control system modules (OMS and FRCS).

Offline Launch Vehicle Ground Systems

- Rotation, Processing and Surge Facility (RPSF): Consists of four facilities located north of VAB including the Rotation/Processing Building, two Surge Buildings and a Shop Building. The Rotation/Processing Building supports aft booster buildup with workstands, 200-ton overhead bridge cranes, and a rail track which traverses through the building (SRB segments are shipped to KSC via rail). Two surge buildings are used for storage of processed Solid Rocket Motor (SRM) components prior to stacking.
- Assembly and Refurbishment Facility (ARF): Performs non-propellant Solid Rocket Booster processing functions including assembly and tests forward skirt, aft skirt, frustum, nose cap, and thrust vector controls. Contains numerous labs, test areas, and an ordinance area for installing booster separation explosives.

Integrated Operations Ground Systems

- Vehicle Assembly Building (VAB): After Apollo, platforms in the High bays 1 and 3 were modified support stacking of the SRBs, ET and Orbiter. ET check-out cells were added to high bays 2 and 4. Initial refurbishment of the Aft Skirts, Forward Skirts and Frustums was performed in the VAB Low Bay before construction of the Assembly and Refurbishment Facility.
- Mobile Launch Platform (MLP): All three Apollo Mobile Launchers were modified to support Shuttle Operations. The Launch Umbilical towers were removed and exhaust exit holes were modified to accommodate the Shuttle SRBs and SSMEs.
- Crawler Transporter: The CT was essentially unchanged from Apollo. Periodic technology upgrades were performed to modernize electronic systems.
- Launch Control Center/Launch Processing System: All computing equipment from Apollo was removed and replaced with the new Launch Processing System (below).
- Launch Processing System (LPS): LPS is used to support offline orbiter operations; stacking operation in the VAB and launch operations on the Pad. It consists of three subsystems including the Checkout, Control and Monitor Subsystem (CCMS); Shuttle Data Center; and Record and Playback Subsystem. CCMS Sets are located in all four Firing Rooms and consists of consoles driven by distributed real-time computers linked via a custom shared memory system. Application Software written in Ground Operations Aerospace Language (developed for Shuttle in the 1970s) runs on computers in the CCMS. The CCMS is the primary means to command and monitor Shuttle operations. The SDC is based on UNIX servers and is used for three major functions: data recording and retrieval; operational software builds for CCMS; and Shuttle Ground Operations Simulator used for launch team training and software check-out. The RPS is used for analog and digital recording of raw measurement data received from the Orbiter.

Landing and Recovery Operations Ground Systems

- Shuttle Landing Facility (SLF): Consists of concrete runway 15,000 feet long, and 300 feet wide with a 1,000 foot paved overrun at each end with landing system aids. Landing Systems include Tactical Air Navigation (TACAN), Microwave Scanning Beam Landing System (MSBLS) and xenon lighting systems. The Mate/De-mate device is located on the ramp at the SLF and is used to remove the Orbiter from the Shuttle Carrier Aircraft following landings in California.
- SRB Retrieval Ships: Two SRB retrieval ships are 176 feet in length, 37 feet in width, and draw about draft of about 12 feet. Each ship displaces 1,052 tons and is driven by two main engines providing a total of 2,900 horsepower.

Launch Operations Ground Systems

- Launch Pad: Both Launch Pads A and B were modified to support Shuttle Operations. Some of the modifications included the addition of the Fixed Service Structures (FSS); Rotating Servicing Structure (RSS); Sound Suppression System; Hypergolic Fuel Farms and new control and data acquisition systems. The RSS contains the Payload Change-out Room (PCR) and provides a clean work area to install payloads into the Orbiter Payload Bay. The FSS also provides weather protection to the Orbiter.



Figure 27: Payload Canister Lifted into PCR [NASA].

Shuttle Support Equipment and Ground Support Equipment

The ground systems described above certainly represent the most visible components of the facilities and equipment required to support Shuttle Operations. However, each of the ground system contains hundreds of SE and GSE components. There are over 4000 'Program Model Numbers' (discrete types of GSE) for Shuttle GSE alone. Each Examples of GSE range from simple RCS covers to complex avionics test equipment. Each type of SE and GSE require sustaining engineering and logistical support. In the Shuttle Logistics facilities at KSC, there are over 180,000 parts.

2.5 International Space Station

Manned space stations orbiting the earth were part of the earliest visions for space travel as far back as the 1869 when Edward Everett Hale described a "Brick Moon" with a crew of 37 orbiting the earth assist crews in navigating the seas for the *Atlantic Monthly*³⁴. A space station was also called for in the Space Task Group report of 1969³⁵. The construction and operation of a low earth orbiting space station was one of the primary reasons for developing the Space Shuttle. However, NASA's budget in the 1970s would not support simultaneous development of both the Space Shuttle and space station. It was not until 1984, when President Reagan announced plans for a new orbiting space station, did detailed concept development begin. The new space station was called Freedom and was to be constructed and serviced by the Space Shuttle. Following seven major redesigns, three presidential administrations, and six congresses, Space Station Freedom was effectively canceled in 1993. President Clinton directed NASA to partner the development of the Space Station with Russians in addition to the Europeans and Japanese who were already supporting Freedom. The new program was called the International Space Station. The first Space Station Assembly flight occurred with the launch of Zarya in 1998 on a Russian Proton launch vehicle. Two weeks later, the Space Shuttle Endeavour delivered the first U.S. element, the Unity Node. Assembly continued through 2002 until the Columbia accident grounded the Shuttle Fleet in 2003. Space Station assembly was resumed in 2005.

Space Station flight hardware elements are delivered to orbit by the Space Shuttle and Russian launch vehicles such as the Proton. When complete, the Space Station's mass will be over 400,000 kg and have a volume of over 1,200 m³. Space Station construction is nearing completion as shown in Figure 28.

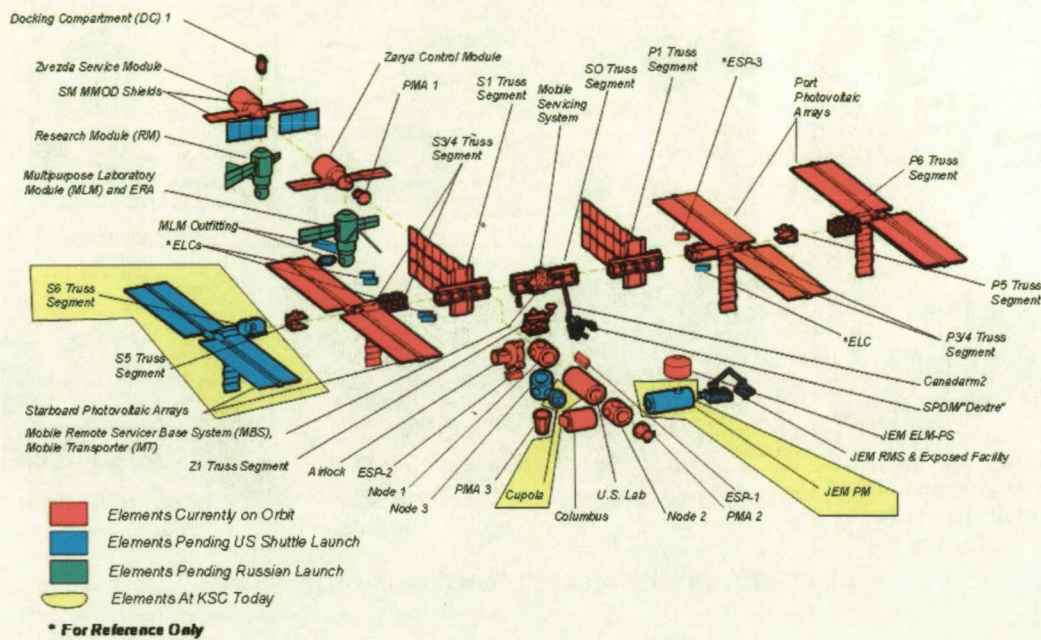

Figure 28: ISS Flight Hardware Configuration [NASA]

Ground Operations Concept

All US, European and Japanese elements are designed to be delivered to orbit via the Space Shuttle and therefore are processed and launched at KSC. Elements arrive via land, sea or air and are transported directly to the Space Station Processing Facility (SSPF) for pre-launch check-out, integration and testing. Processing activities performed at KSC include: assembly of hardware; integration of components and sub-systems; pre-flight fluids servicing; subsystem and element standalone testing; Multi Element Integrated Testing (MEIT); flight acceptance requirements verification; crew equipment interface testing; on-orbit constraints testing; and Shuttle interface testing. Pre and post launch processing of the reusable Multipurpose Logistics Modules (MPLM) and ISS research experiments are also conducted in the SSPF. Once integration testing is complete, the element is loaded in the specially designed payload canister and transported to the either Orbiter Processing Facility or launch pad for installation into the Orbiter payload bay. The end-to-end flow is shown below in Figure 29.

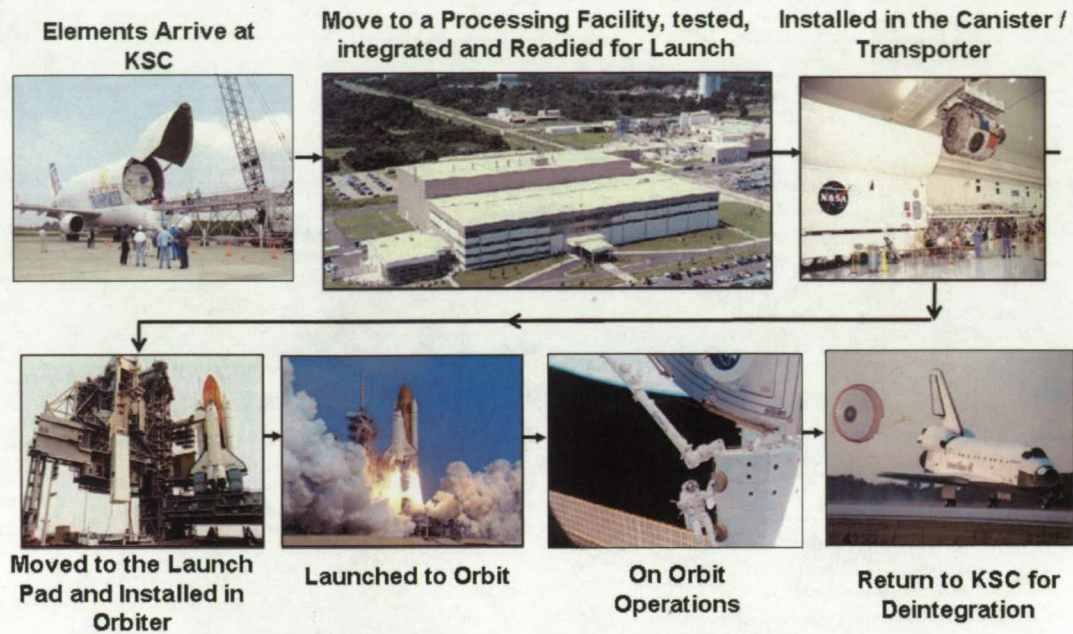

Figure 29: ISS Element Processing Flow [NASA]

One unique aspect of Space Station processing at KSC is the Multi-Element Integration Test (MEIT). Early in ISS program, a ‘ship and shoot’ philosophy was assumed for the flight hardware. Ship and shoot implies flight hardware arriving at KSC is essentially flight ready without the need for standalone or integrated tests. As the program matured and the risks of the Ship and Shoot approach emerged during the design process, a series of MEITs were planned and conducted to validate the operation of the flight elements and their systems in an environment that is as flight-like as possible.. The MEITs also demonstrated interoperability and functionality of Space Station elements as integrated “in-space” assemblies before they were assembled in space for the first time³⁶. MEIT hardware configure is shown below in Figure 30.

based real-time control/data acquisition systems. Ground systems and ISS flight elements used for the second MEIT in the SSPF high bay are shown below in Figure 31.

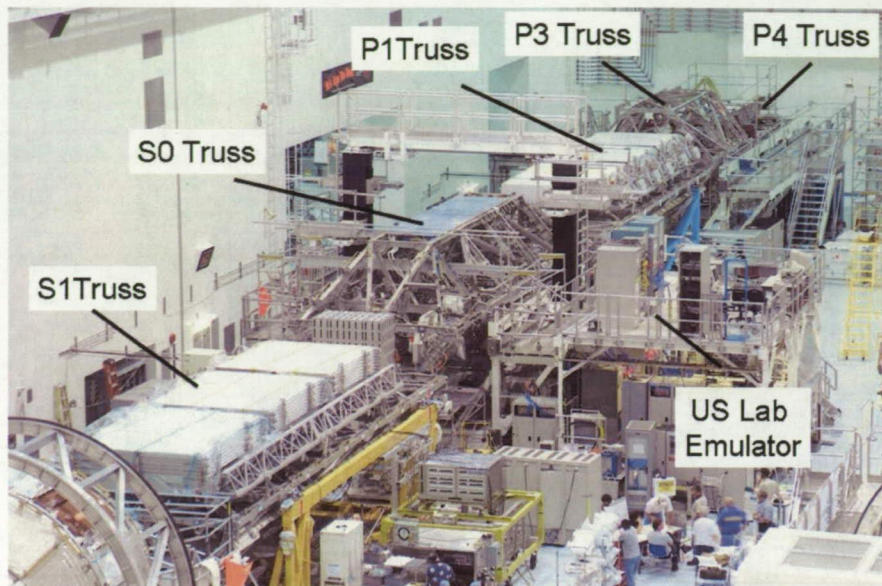

Figure 31: MEIT 2 Underway in the SSPF [NASA]

2.6 Constellation

The Constellation program was initiated as part of the Nation's Vision for Exploration (VSE) announced in January 2004. The vision established a new direction for the US Space Program leading to renewed human exploration of the Earth's moon by 2020 and eventual exploration of Mars. Virtually every program and project within NASA was affected by the announcement as resources within the agency were refocused on the new objectives contained in the vision. Some of the more significant objectives included in the announcement include: the retirement of the Space Shuttle following completion of the International Space Station (ISS) in 2010; the development of a new Crew Exploration Vehicle (CEV) to carry astronauts first to the International Space Station and on to the moon; renewed robotic exploration of the moon and continued robotic exploration of the solar system including Mars; and the development of a commercial capability to resupply the International Space Station.

The development of the spacecraft, launch vehicles and ground systems required for supporting missions to ISS and moon is the responsibility of the Constellation Program. The Constellation Program consists of several flight and ground operations projects including Orion, Ares, Mission Operations and Ground Operations.

In 2005, NASA completed the Exploration Systems Architecture Study (ESAS) that established initial ISS and lunar mission profiles and the flight hardware architecture currently under development by the Constellation Program. Since completion of the study, the flight hardware and ground systems projects have made significant progress. High level descriptions of spacecraft, launch vehicle and ground systems are included below.

Spacecraft Elements

Orion Crew Exploration Vehicle (CEV) accommodates up to six crewmembers for missions to ISS and up to four crew members for lunar missions. It is designed to operate for up to 210 days in earth or lunar orbit. It consists of the Launch Abort System (LAS), Crew Module, Service Module and Spacecraft Adapter as shown in Figure 32.

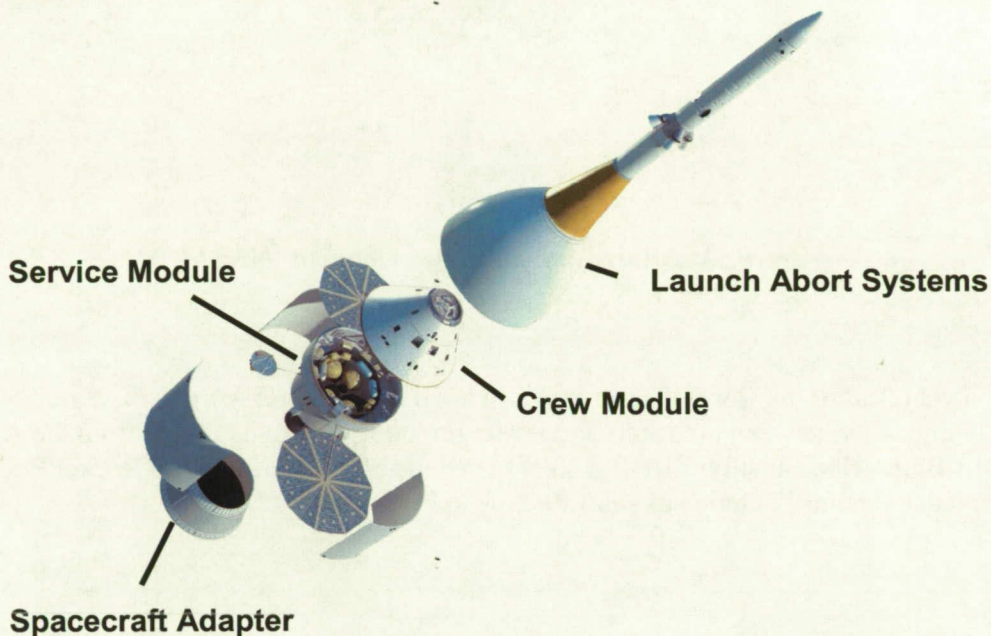

Figure 32: Orion Crew Exploration Vehicle (CEV) [NASA]

The Lunar Lander is still in the early phases of concept development. When complete, it is expected to provide the capability to land a crew of 4 on the lunar surface for missions lasting initially from 7-14 days; provide the capability to land 500kg of cargo on crewed missions and return up to 100kg of lunar samples to the CEV. It will also be able land autonomously in a cargo only mode. The crewed version of the Lander will consist of an Ascent Module, Descent Module and Airlock. The current lander concept is shown below in Figure 33.

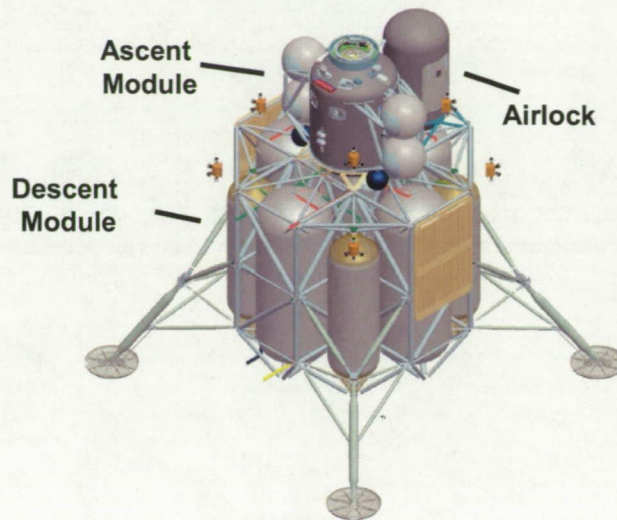

Figure 33: Altair Lunar Lander Concept [NASA]

Launch Vehicle Elements

The launch vehicles for the Constellation Program are the Ares I and Ares V. The architecture utilized commonality between programs and leveraging off heritage hardware from the Apollo and Shuttle. Both vehicles will utilize 5 segment versions of the Shuttle Solid Rocket Boosters and an upgraded Apollo J2 engine as shown below in Figure 34.

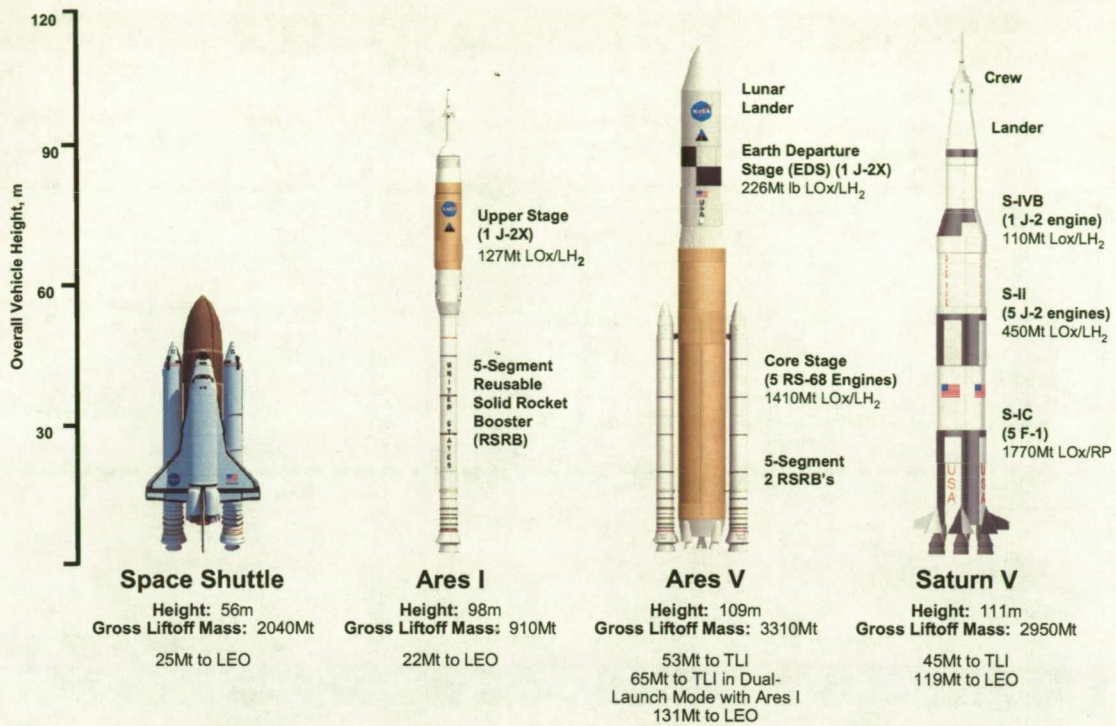

Figure 34 : Constellation Flight Hardware Commonality with Apollo and Shuttle [NASA]

For lunar missions, the crew will be launched into low earth orbit by the Ares I. Altair and the EDS will be launched by the Ares V within 24 hours. Orion will dock with Altair/EDS in LEO. The EDS will perform the trans-lunar injection burn for the 3 day journey to the moon. As the spacecraft nears the moon, the EDS will be discarded and Altair will perform the lunar orbit injection burn. The entire crew transfers to Altair, undocks from Orion and lands on the lunar surface. The crew performs lunar surface activities initially from 7-14 days then departs from the lunar surface via the Ascent Module and re-docks with the Orion waiting in lunar orbit. The Orion Service Module performs the trans-earth injection burn. Once Orion nears the earth, the Service Module is jettisoned, the Crew Module re-enters the earth's atmosphere and lands near the south west coast of California for recovery and retrieval operations. The Lunar Mission profile is shown graphically below:

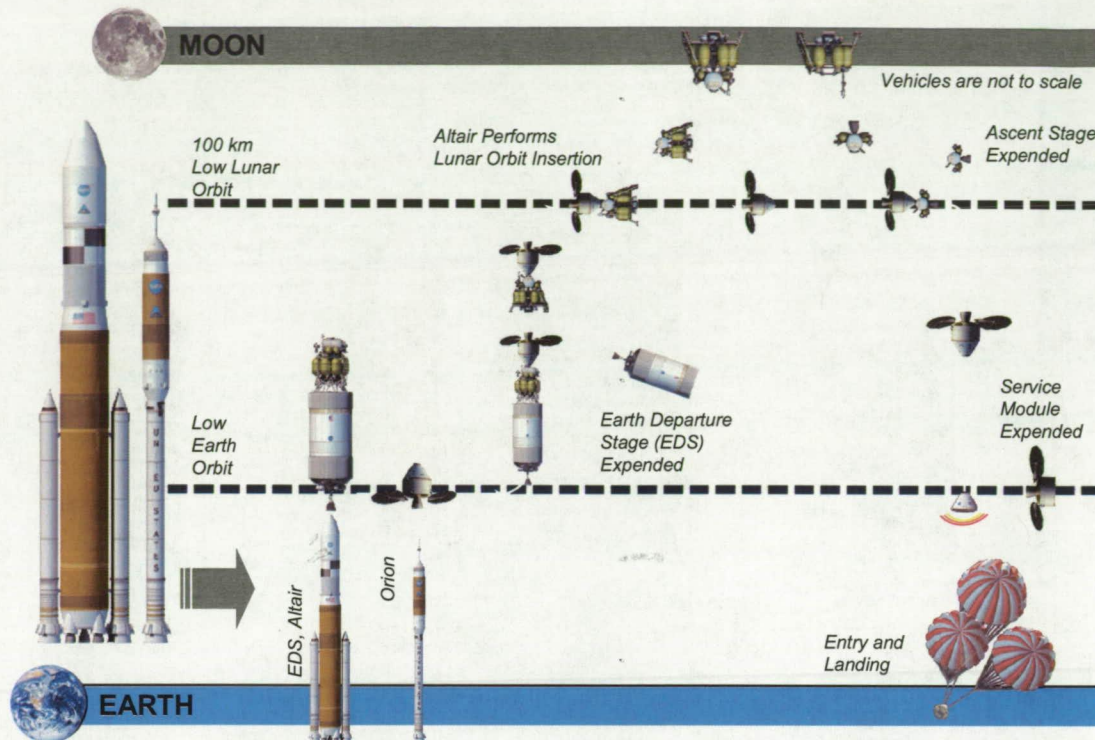

Figure 35: Constellation Lunar Mission Profile [NASA]

Constellation Ground Operations

A phased approach is planned for the development of Ground Systems to support missions to the International Space Station and to moon. The first phase is referred to as 'Block 1' and includes the required capabilities to process and launch the Orion Spacecraft and Ares I launch vehicle for missions to the International Space Station. The second development phase is referred to as 'Block 2' and includes additional capabilities to process the Lunar Lander (Altair) and the Ares V cargo launch vehicle. The section includes descriptions for both Block 1 and Block 2 ground systems.

Ground Operations Concept

The ground operations concept for both Ares I/Orion and Ares V/Orion leverages of the mobile launch concept developed for Apollo subsequently used in Shuttle. Launch Vehicle and Spacecraft elements are turned over to Ground Operations following manufacturing and assembly for preflight processing and launch. The overall processing flow for Ares I/Orion is shown in the following Figure:

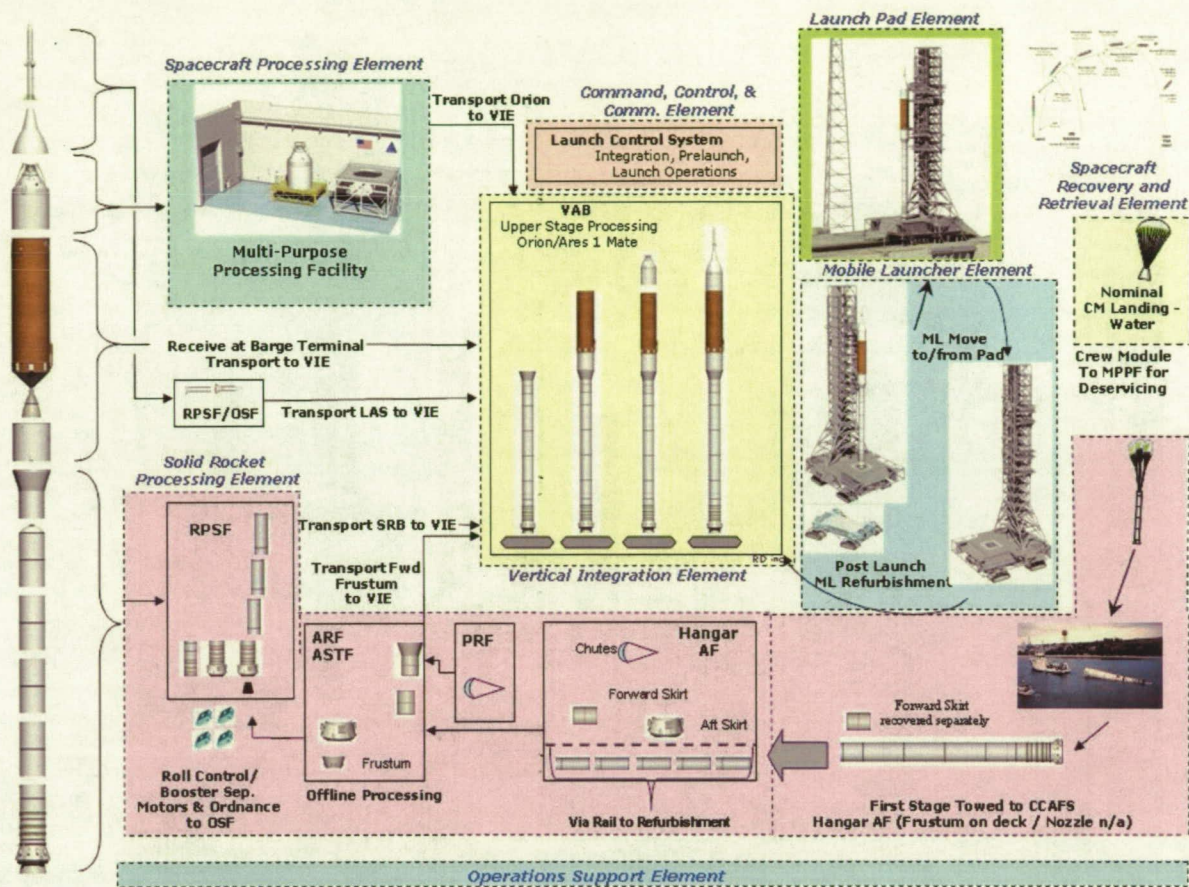

Figure 36: Ares I/Orion Ground Processing Flow [NASA]

Ground processing concepts for the Ares V and Altair shown in the Figure 37 below are based on preliminary Launch Vehicle and Spacecraft vehicle configurations. Several launch vehicle, spacecraft and ground processing trade studies were underway at the time of this writing.

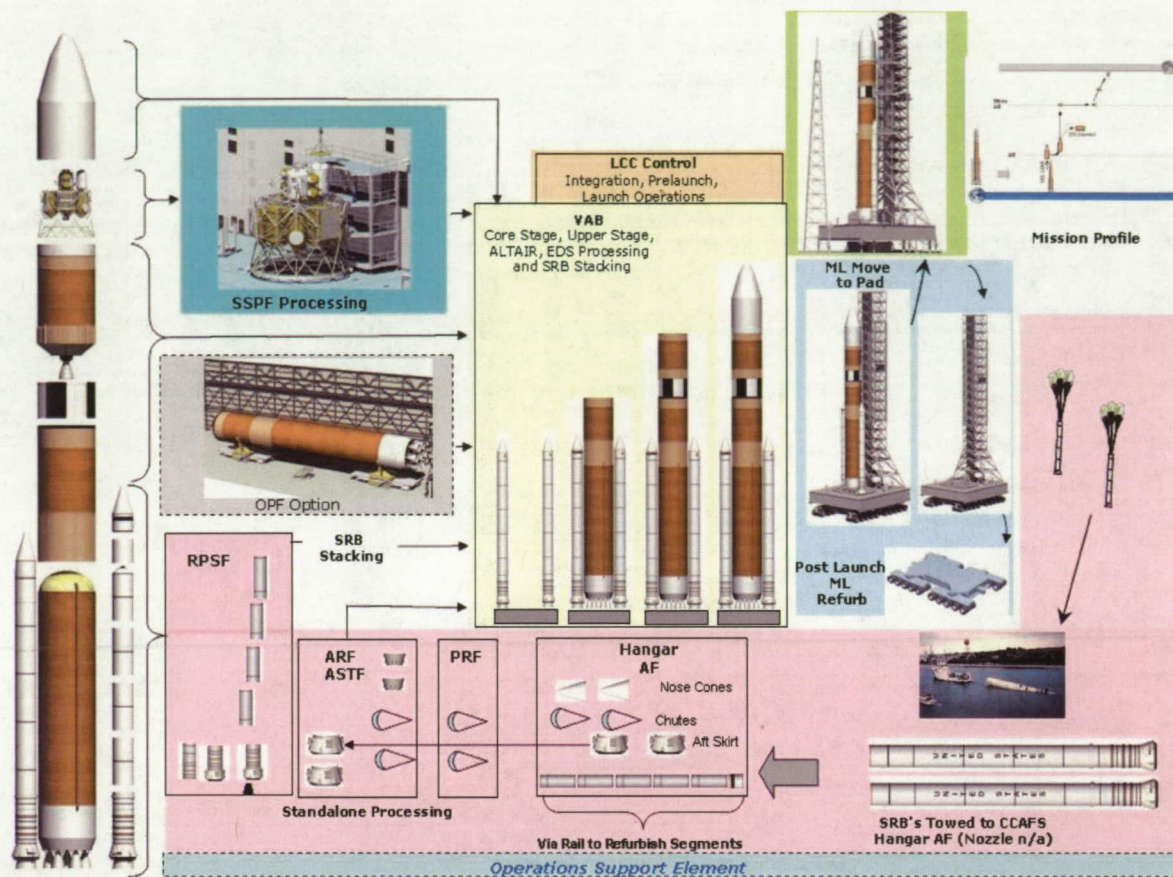

Figure 37: Ares V/Altair GS Flow [NASA]

One notable exception to Apollo and Shuttle ground processing flows is the amount of processing time required for the integrated stack while at the launch pad. Many operations performed at the launch pad are critical path and any problems encountered during those operations increase the likelihood of launch delays. Furthermore, access requirements increase as the number of operations at the launch pad increase thus requiring additional ground systems at the pad exposed to the sea side environment. The Apollo Mobile Service Structure and Shuttle Fixed Service Structure are examples of such ground systems. Annual operations and maintenance costs for maintaining structures located immediately next to the coast are higher than those protected in an enclosed environment such as in the VAB. Analysis of Apollo and Shuttle workflows indicate a benefit to minimize on pad time as much as possible.. One operation in particular is spacecraft hypergolic loading. During the Apollo and Shuttle programs, hypergolic loading was performed at the pad. Only essential personnel properly trained and protected in Self Contained Atmosphere Protective Ensemble (SCAPE) Suits are allowed in the area. No other operations at the pad were allowed during propellant loading. In Constellation, hypergolic loading of the Orion spacecraft will in occur in the Multi-Payload Processing Facility (MPPF) removing a critical path task from the pad processing.

Constellation Ground Systems Architecture Overview

The Constellation Ground System consists of Facilities, GSE and Support Equipment required for performing services at the launch, landing, and retrieval sites. As with Apollo, Shuttle and ISS, functions provided by the Ground System include receipt of flight hardware elements, software, cargo, and ground support equipment; off-line spacecraft and launch vehicle processing; spacecraft and launch vehicle integration; launch operations; spacecraft recovery and retrieval; contingency operations such as search and rescue; and logistics functions. The overall Constellation architecture is broken down into levels. Launch vehicles, spacecraft and ground systems are considered 'Level III' systems for the purposes of system wide architectural decomposition. Each system is then broken down into 'Level IV' elements. The Ground System is broken in down into 8 elements as shown below in Figure 38.

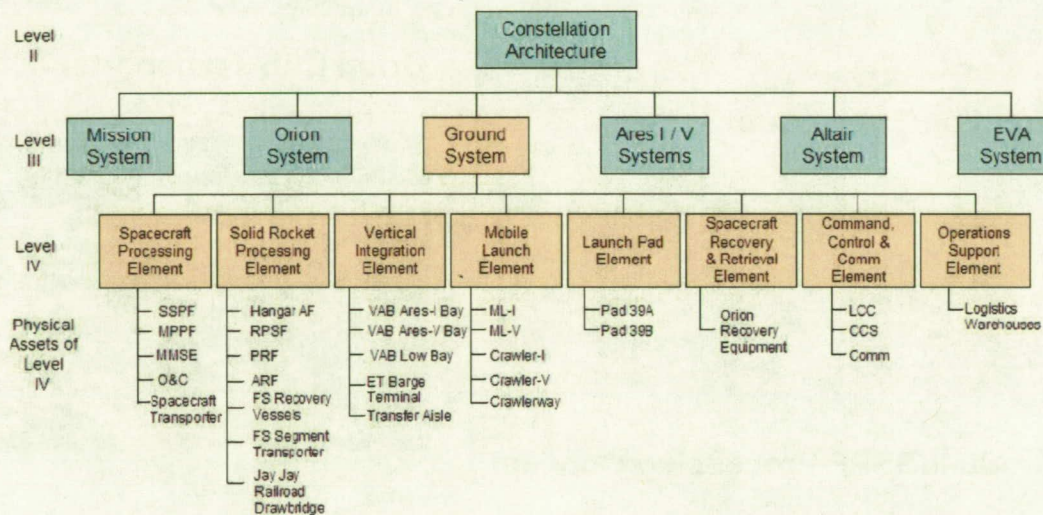
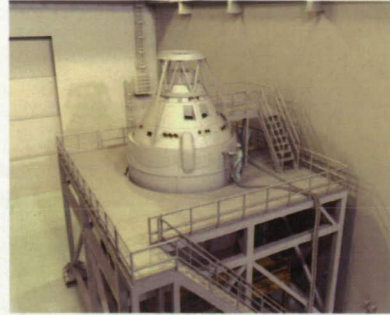

Figure 38: Constellation Ground System Architecture [NASA]

Spacecraft Processing Element: Consists of facilities, FSE, GSE and SE required to perform off-line processing of the Orion and Altair Spacecraft. Final manufacturing and assembly occurs at KSC under the direction of the Orion Project at the Johnson Space Center who is responsible for the production of the Orion spacecraft. Although the activity occurs at KSC, it is not considered part of ground operations. The partially integrated spacecraft is turned over the Ground Operations Project prior to transportation from the O&C High Bat to the Multi-Payload Processing Facility (MPPF). The Orion Spacecraft is partially integrated during final manufacturing and assembly in the Operations and Check-out building at KSC. The MPPF provides a clean work area, space for work stands and access platforms services required to perform off-line check-out of the integrated Orion Crew Module, Service Module and Spacecraft Adapter. Offline operations are supported by Multi Mission Support Equipment and consist of transporters such as the KMAG, tugs and dollies; handling equipment; strong backs and lifting slings. Prior to transportation to the VAB for integrated operations, hypergolic propellants are loaded on the spacecraft. Similar operations are planned for Altair and are planned to take place in the Space Station Processing Facility.



MPPF



Orion Work Stands



Orion on Transporter



Orion LAS Transporter

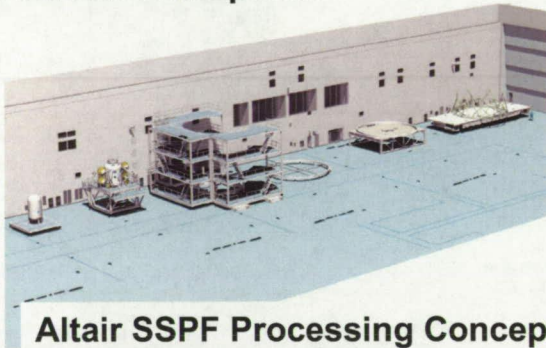

Altair SSPF Processing Concept



SSPF

Figure 39: Spacecraft Processing Elements [NASA]

Solid Rocket Processing Element (SRPE): Consists of facilities, FSE, GSE and SE required to perform off-line processing of the Ares I First Stage. The First Stage consists of a five-segment Solid Rocket Booster derived from the Space Shuttle. The existing SRB Rotational Processing and Surge Facility, GSE and SE will be reused from the Space Shuttle Program to support Ares I. An additional Surge Facility (for SRB segment storage) and GSE will be required to support Ares V SRB element processing. The SRPE also consists of the Assembly Refurbishment Facility (for SRB Aft Skirts, Frustum, Forward Skirts, Nose Cap and Thrust Vector Controllers), and Parachute Refurbishment Facility (PRF). SRBs recovered following flight are returned to Hanger AF for post flight inspections and disassembly. Once residual propellant is removed, SRB segments are sent by rail back to the manufacture to be refurbished refilled with propellant. The Aft Skirts, Forward Skits, Frustum and Nose cape are transported by road back to the ARF.

Vertical Integration Element: The VIE consists of facilities, FSE, GSE and SE required to stack and integrate the Ares launch vehicles with Orion and Altair spacecraft. The Vertical Integration Element is allocated to the Vehicle Assembly Building and the existing KSC Barge Terminal. The Ares I Upper Stage and Ares V Core Stage arrive at KSC via the Barge Terminal and will be

moved directly into the VAB. A 'ship to integrate' philosophy is planned for the Ares I upper stage and Ares V Core Stage. Minimal offline processing is planned for these two elements.

The current Ground Operations baseline includes one VAB high-bay for Ares I processing and one VAB high-bay for Ares V processing. The VAB provides interfaces to the ML and access to the Ares I and Orion/LAS via movable work platforms. Examples of the facility services include cranes, access platforms and lightning/weather protection. For Ares I/Orion stacking, the VAB will be used to integrate the Orion Launch Abort Systems to the CM/SM/SA; stacking and mating of the Ares I First Stage Solid Rocket Booster segments; mating of the Upper Stage to the First Stage; and stacking mating of the Orion/LAS to the Ares I Upper Stage. Integration tests are performed with the entire stack prior to role-out to the launch pad. Concept drawings for the Ares VAB high-bays are shown below. Note the extensible platforms for the Ares I and Ares V. The platforms represent the most significant component of the VAB modifications required for Constellation.



Ares I VAB High-Bay

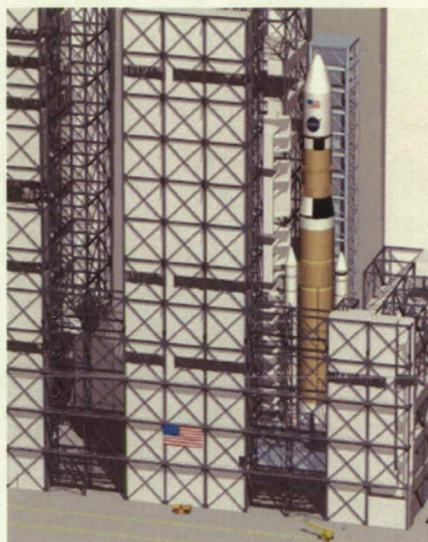

Ares V VAB High-Bay

Figure 40: Ares VAB High-bay Concepts [NASA]

Mobile Launch Element: The Mobile Launch Element consists of two systems: the Mobile Launcher and Crawler Transporter. The Mobile Launchers provides the structure and equipment required to stabilize, integrate, test, service, transport, and launch the integrated stack. The launch vehicle is attached to the Mobile Launcher Base. The Mobile Launch Tower (MLT) provides access and services to the spacecraft and launch vehicle via swing arms. For Ares I/Orion, the MLT provides a crew access arm for astronaut ingress and egress from the spacecraft. The MLT also provides the flight and ground crews access to the emergency egress system on the launch pad. Due to the substantial differences in configuration between the Ares I and Ares V, the Mobile Launchers are unique as shown in the following concept drawings.

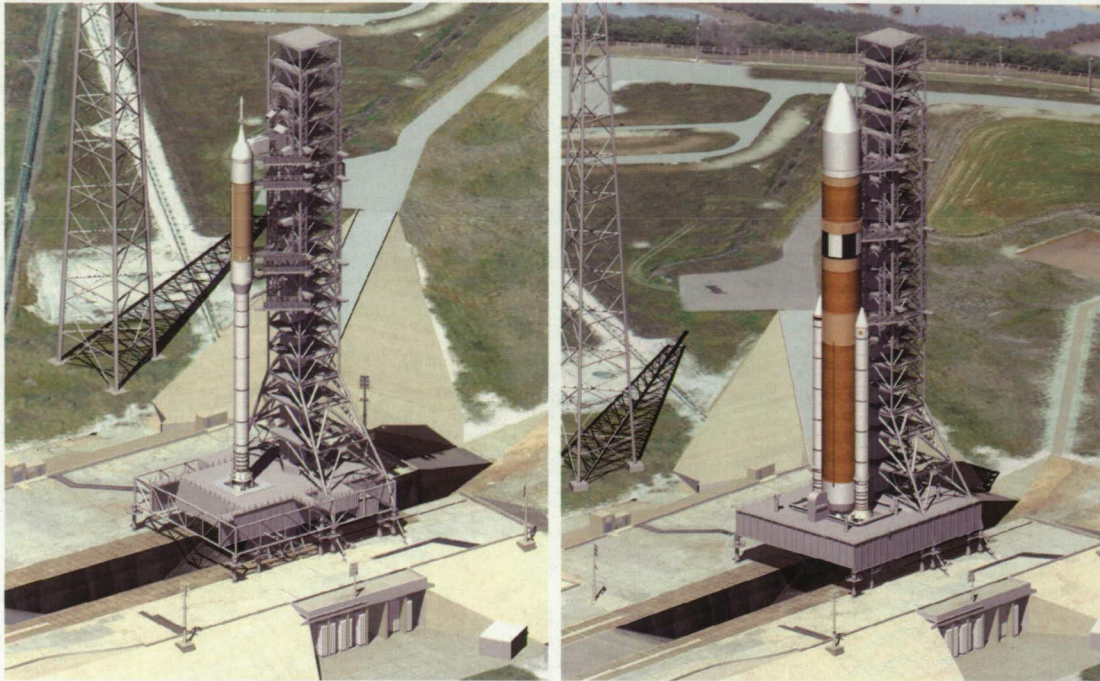

Ares I Mobile Launcher

Ares V Mobile Launcher

Figure 41: Concepts for Constellation Mobile Launchers [NASA]

The Crawler Transporter used during the Apollo and Shuttle Programs will be reused for Constellation Ares I/Orion missions to ISS. Modifications may be required for Ares V depending on the combined weight of the Ares V and Ares V Mobile Launcher.

Launch Pad Element: The Launch Pad Element consists of both Launch Complex Pads 39A and 39B. Pad B will be used to support Ares I/Orion and Pad A will be used to support Ares V/Altair. In conjunction with the Mobile Launchers, each Launch Pad provides the necessary services and structure to support pre-launch and launch operations. The launch facilities include cryogenic propellant storage and servicing equipment, electrical systems, a flame trench and flame diverters, a safe haven for emergency egress, the fixed portion of the Emergency Egress System, lightning protection for the integrated stack and Mobile Launcher, weather data instrumentation, pneumatic service and storage, pressurant service and storage, heating, ventilation, and air conditioning (HVAC), potable water, breathing air, accommodation for the Paging and Area Warning System (PAWS), and electrical systems.



Figure 42: Constellation Ares I Pad [NASA]

Spacecraft Recovery and Retrieval Element (SRRE): The SRRE provides ground systems to support recovery and retrieval of the Orion Crew Module. This element is the only element that will predominately be used beyond the physical boundaries of KSC at the Orion Recovery and Retrieval Sites. The nominal landing mode for Orion is on water near the southern California coastline. Orion will also be capable of contingency land landings. The SRRE includes ships, cranes, handling equipment, access equipment, and an aircraft to safely recover the flight crew and Orion Crew Module.

Command, Control & Communications Element (CCCE): The Command, Control and Communications Element contain control center facilities, command and control systems, and communication systems. The Launch Control Center is the primary control facility and contains 4 control rooms. For Constellation, only two of the four control rooms are planned to be used. Control room one will support Ares I/Orion and control room four will be used for Ares V/Altair. The primary Command and Control System for off-line spacecraft operations and all integrated stack operations in the VAB and on the launch pad is the Launch Control System (LCS). LCS sets will be located in the MPPF and Launch Control Center. The Complex Control System (CCS) is used to monitor and control facility systems such as HVAC, Pneumatics, Firex, Power and Oxygen Monitoring Systems in the Vertical Integration Element. Communication systems include voice, video (imagery), and data systems which interface with the flight systems, the (CCS), and other GS elements. CCCE supports operations in all other ground system elements, a characteristic unique to Command, Control and Comm Element.

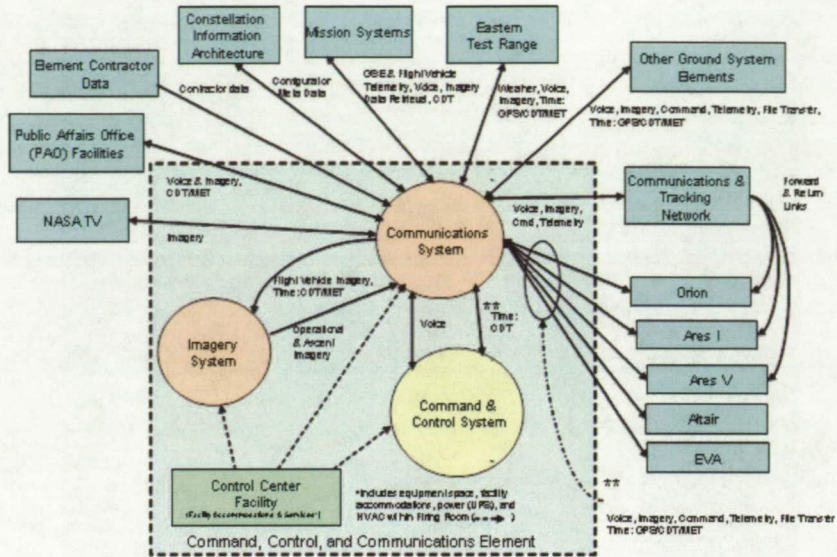

Figure 43: Command, Control and Communication Element [NASA]

Interfaces between LCS the VIE, LPE and SPE are shown in the following Figure 44 below.

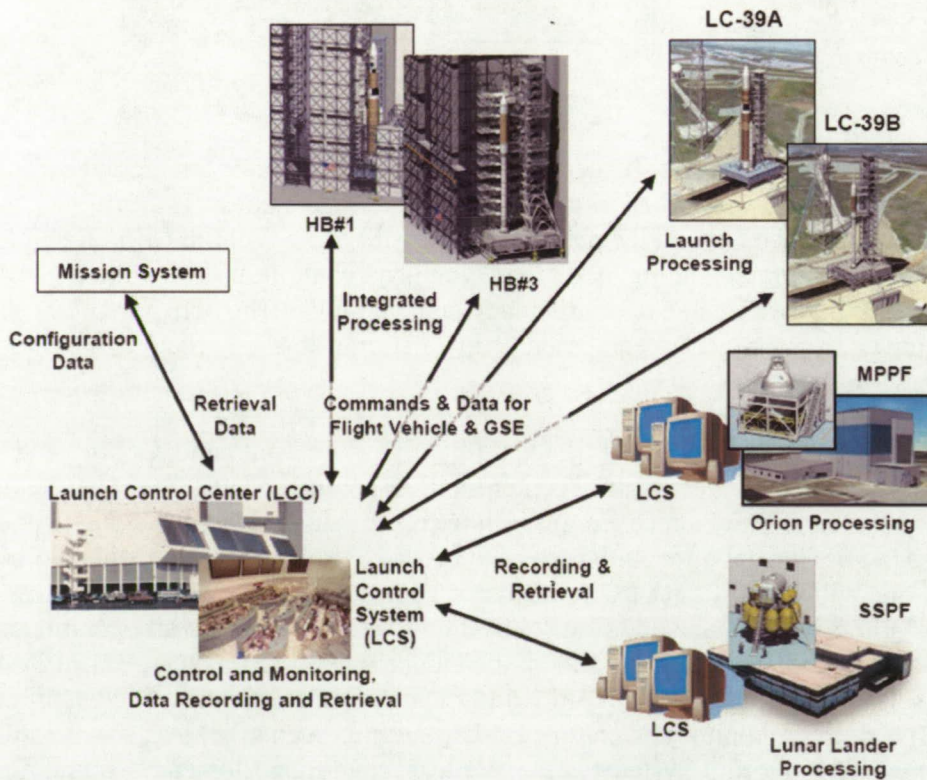

Figure 44: LCS Interfaces [NASA]

Operations Support Element (OSE): The OSE captures a diversity of systems and functions required to support the launch site such as logistics, base operations services and coordination of services provide by the local community. Logistics includes warehousing facilities; initial/replenishment/spares acquisition; material and inventory management systems; depot operations such as propellants and life support commodities and spacecraft recovery transportation. Base operations services includes weather services and onsite meteorological systems; KSC emergency planning and response, base security, integrated operations management systems such as Integrated Work Control Systems, environmental management, and KSC transportation infrastructure (roads, rails, air). The OSE also coordinates and ensures compatibility between on-site systems and local emergency response organizations.

Constellation Ground System Interfaces

The elements work in conjunction to perform ground operations at the launch site and landing and recovery sites. Interfaces between the elements and systems external to KSC Ground Systems is shown below:

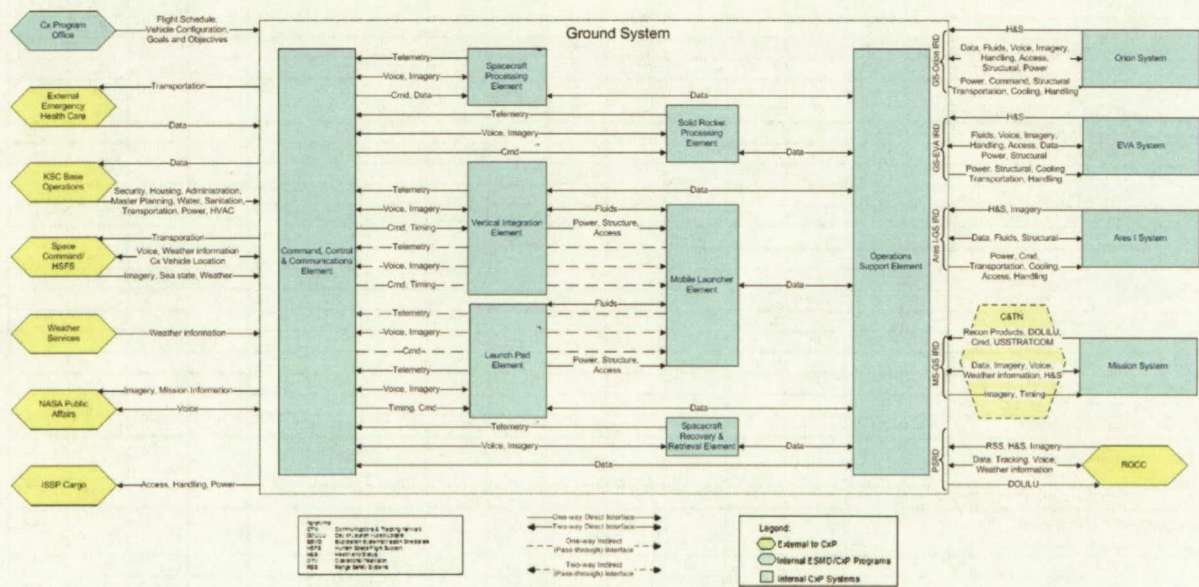

Figure 45: Ground Systems Interfaces (Block 1 only) [NASA]

The elements map to the objects and processes described earlier in the chapter as shown in the following table:

Table 1: Constellation Ground Systems Element Mapping to System OPD

Constellation Ground System Elements	Internal Launch Site Ground System Objects						Internal Launch Site Processes								
	Offline Spacecraft Ground Systems	Offline Launch Vehicle Ground Systems	Integrated Operations Ground Systems	Launch Operations Ground Systems	Landing and Recovery Operations Ground Systems	Logistics Systems	Offline Cargo Processing	Offline Launch Vehicle Element Processing	Offline Spacecraft Element Processing	Flight Crew Preparing	Integrated Spacecraft Processing	Integrated Spacecraft/Launch Vehicle Operations Processing	Launch Operating	Landing and Recovery Processing	Logistical Items Processing
Spacecraft Processing Element															
SSPF	X						X		X						
MPPF	X						X		X	X					
MMSE	X						X		X						
O&C									X						
Spacecraft Transporter	X								X	X					
Solid Rocket Processing Element															
Hanger AF					X									X	
RPSF		X												X	
PRF		X												X	
ARF		X												X	
FS Recovery Vessels														X	
FS Segment Transporter		X	X								X			X	
Jay Jay Rail Road Draw Bridge		X				X		X						X	
Vertical Integration Element															
VAB Ares-I Bay			X							X					
VAB Ares-V Bay			X												
VAB Low Bay			X									X			
ET Barge Terminal			X					X			X				
Transfer Aisle			X					X			X				
Mobile Launch Element															
Ares I Mobile Launcher			X	X						X	X				
Ares V Mobil Launcher			X	X							X				
Ares-I Crawler			X	X							X	X			
Ares-V Crawler			X	X							X	X			
Crawlerway			X	X							X	X			
Launch Pad Element															
Pad 39A (Ares V)				X									X		
Pad 39B (Ares I)				X					X				X		
Spacecraft Recovery and Retrieval Element															
Orion Recovery Equipment														X	
Command, Control and Communication Element															
LCS	X	X	X	X	X	X	X	X	X	X	X	X	X	X	
CCS	X	X	X	X	X	X	X	X	X	X	X	X	X	X	
Comm	X	X	X	X	X	X	X	X	X	X	X	X	X	X	X
Operations Support Element															
Warehouses						X									X

Level 5 Subsystems

The elements capture at the highest levels ground systems required to support offline processing, integrated operations and launch operations. Below the level IV elements are level V subsystems. Many of these subsystems support multiple elements. An ‘end to end’ description of a subsystem will often include subsystem components that are present in 2 or more elements as shown in Figure 46:

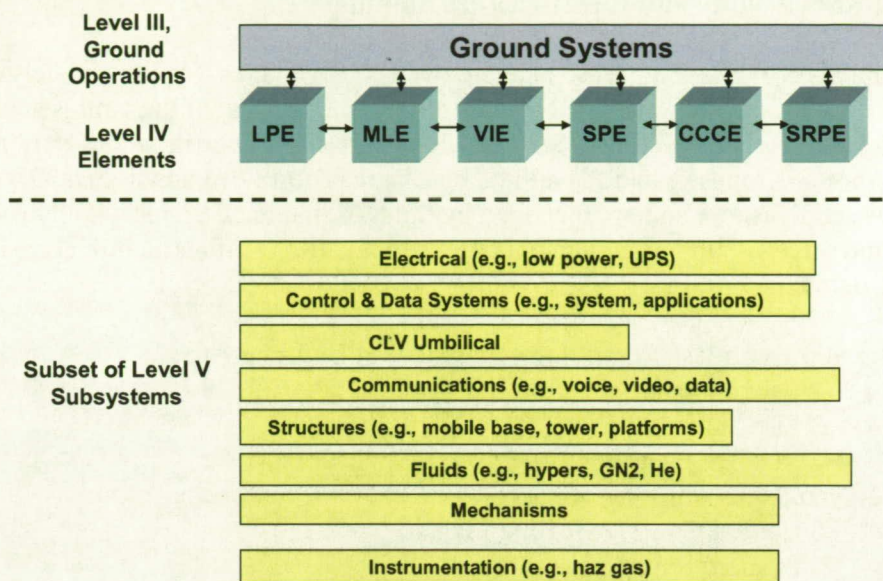

Figure 46: Level V Subsystems [NASA]

Figure 46 shows only a subset of the over 70 level V subsystems currently under design for the launch site for Block I. The subsystems are divided into 9 categories.

Table 2: Level 5 Subsystems

Subsystem Category	Number of subsystems within category	Examples
Fluids	6	Ares I Liquid Oxygen (LO2) Fill and Drain System; Freon; Hypergolic Servicing/ De-servicing System
Gases	6	Environmental Control System (ECS); Gaseous Helium; Gaseous Nitrogen
Mechanical	18	Vehicle Assembly Building (VAB) Access Platforms; Handling and Access – VIE Equipment; Spacecraft Transporter; Emergency Egress System (EES)
Electrical	11	Hazardous-Gas Leak Detection System; Radio Frequency Monitoring System; First Stage Thermal Control System
Command and Control	3	Launch Control System (LCS); Portable Orion Avionics Integration Laboratory; Kennedy Ground Control System
Communications	7	Operational Intercom System; Telephone System; Paging & Area Warning System
Imagery	3	Operational Television; Broadband Communications Distribution System; Imaging System
Facility	22	ML Structure (Base and Tower); Uninterruptible Power Supply; Cranes
Miscellaneous	2	Laser Alignment System; Ordnance System

2.7 Current KSC Facility and Infrastructure Summary

Today, the Kennedy Space Center (KSC) covers over 140,000 acres. Approximately 70,000 acres of estuary are deemed a system of National Importance. Most of the land is actually managed by the U.S. Fish and Wildlife Service and is part of the Merritt Island National Wildlife Refuge. The Apollo, Klondyke and Playalinda beach areas north of Launch Pad 39B are part of the Cape Canaveral Seashore and are managed by the National Park Service. Only 6,800 acres are disturbed and directly support launch operations today. KSC infrastructure currently in place is summarized below:

- Over 900 Facilities/ 7.6 million square feet of Building Area
 - 2 Launch Pads
 - 3 Fire Stations
 - 2 Medical Facilities
- Energy and Gases
 - 3 Central Cooling/Heating Plants
 - 2 Primary Substations
 - 270 miles of Electrical Distribution Lines
 - 60 miles of high pressure Helium/Nitrogen Pipelines
- Shuttle Landing Facility (15,000 foot runway)
- 213 miles of Roadway
- 2 Sea Docks
- 40 miles of Railroad
- 5 Major Bridges
- Current Replacement Value as of 2008: \$4.7B

The following Figure illustrates land use on the Kennedy Space Center and Cape Canaveral Air Force Station as of 2004.

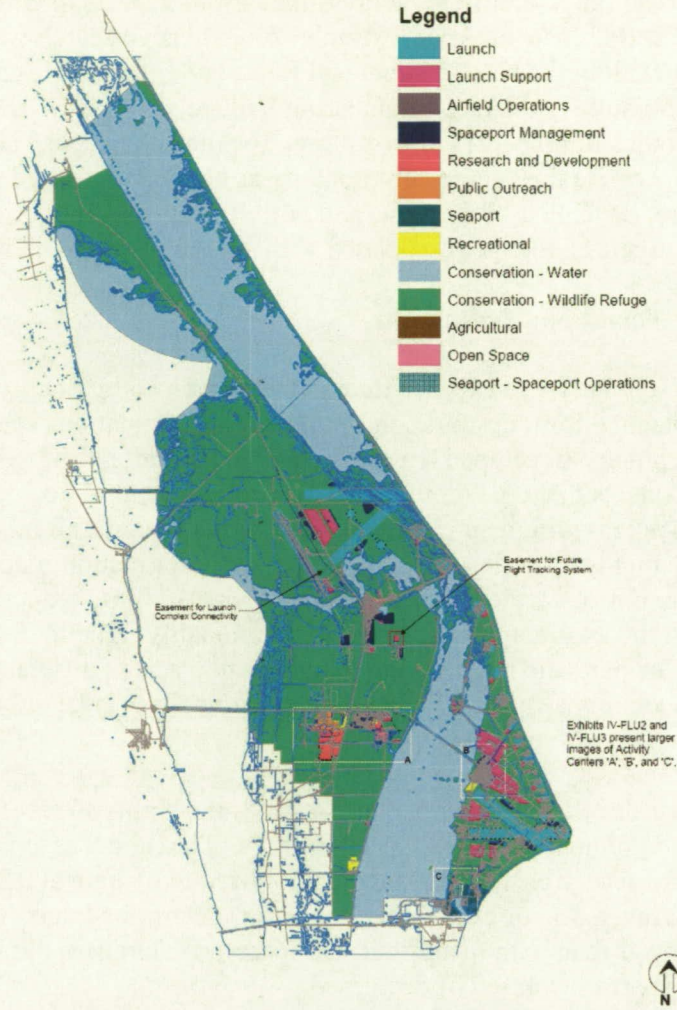

Figure 47: KSC and CCAFS Land Use (2003) [NASA]

3 Literature Review

Summaries from a broad range of articles addressing various aspects of commonality are provided to capture the dominate areas of research. An extensive search was performed in electronic libraries including the NASA Technical Reports Server, American Institute of Aeronautics and Astronautics (AIAA), Engineering Village's COMPENDEX, Institute of Electrical and Electronics Engineers (IEEE) Xplore, ENGnetBASE, etc. The primary goals of the search were to determine the degree commonality as applied to ground systems was addressed in literature; develop a set of terms and definitions; seek out potential analysis methods and to investigate challenges associated with applying commonality.

3.1 Commonality Terms and Definitions

The vast majority of scholarly work in literature is focused on commonality as applied to spacecraft systems planned for long-duration spaceflight to destinations such as the moon and mars. Kline and Bachman³⁷ developed a model to capture the effects of two types of commonality: components that are common across elements (e.g., spacecraft) and those that are common across subsystems within an element. The model addresses all mission phases with several co-located elements (meaning they can share spares for common items) as well as phases with elements that are not co-located and cannot share spares. Mass reductions ranged from 11 to 32% depending on the assumptions for level of commonality. The models also suggest 33–50% fewer spares if the parts are reconfigurable or common across different mission elements for Mars missions. Commonality is considered at the component level only sharing the same hardware characteristics and functions.

Siddiqi and de Weck³⁸ developed a model that considers the ability to reconfigure hardware to also address mass and volume issues for space missions. The model assumes parts in elements are reconfigurable, are accessible and that they do not have to operate at the same time. By allowing temporary scavenging or cannibalization it was determined that availability with dedicated spares is lower than with reconfigurable spares. Differences did not seem to change when the number of spares increased or decreased.

While most papers and plans define commonality in terms of design and physical form, Crawley, Hofstetter and Wooster³⁹ offer expanded definition to include functional, architectural, operational, technology, design and reusability commonality. At a minimum, for two objects or systems to exhibit commonality they must possess same functions but not necessarily the same form. This forms the basis for a hierarchy beginning with the functional type. Similarities with respect to design and physical form increases as two objects exhibit architectural commonality. Thus similarities increase through each successive type (functional->architectural->operational->technology->design->reusability). Crawley, Hofstetter and Wooster also suggest that as the level of commonality increases, so do benefits in terms of reduced DDT&E cost, reduced DDT&E risk, production cost, operations cost and operations risk.

3.2 Platform Based Product Development

Platform-based product development allows for the development of several products originating from a single base design. By using common processes, infrastructure, design and parts, near-term development costs are lower when compared to the development of independent products. Commonality to some degree is achieved by reusing the platform across multiple products. Boaz and Crawley⁴⁰ describe sequential and parallel platform product development. In sequential product development, a single product is designed and produced by a single development team. Follow-on products based on the original platform are developed and produced later in time by the same or new development teams. While both approaches offer long-term life cycle cost benefits, for parallel platform the benefits are realized sooner than with the sequential approach. For the sequential case, the platform may be over optimized for the first product since requirements for follow on variants are still at concept level only and organizational emphasis is placed on the first product.

3.3 Commonality and Ground Systems

As stated in the introduction, no articles were found that specifically address commonality as applied to ground systems at any launch site (KSC, French Guiana, etc). A number of articles were found that address commonality in systems used in satellite ground systems. The vast majority of those articles were centered on software reuse in mission planning, data distribution, command and control, etc.

Dussauze et. al. describe how the ground segments are developed today typically using one of three methods: by purchasing a Commercial Off the Shelf System and adapting for a particular application; by designing and building a custom solution; and by selecting the best of several products for each requirement function and integrating them. The third choice seems to offer the most cost effective way to optimize to a particular solution by allowing only the best products to be selected for a given function, the costs of integrating often negates the benefits despite the use of industry standards such as JAVA, C++, CORBA, etc. In an attempt to address these drawbacks, European Space Agency is leading an effort to define component interfaces that are driven by 'provided services' and 'required services' for each major function. EADS Astrium identified the following functions to be common within the ground segment across multiple satellite systems: Procedure Preparation and Execution; Plan Preparation and Execution; Flight Dynamics; System Database Management; and Ground Equipment Monitoring and Control.

Satellite manufactures typically utilize proprietary test and check-out systems to develop, integrate and test a satellite with little to no regard of the systems that will be used to operate the satellite. Monham and Quigley⁴¹ describe inefficiencies they call 'cost hot spots' in the transfer of operations knowledge during development and test of satellites. The process of building and transferring operations knowledge occurs in two major stages. During development, the satellite prime and subcontractors create multiple data bases and procedures to test components, subsystems, systems and eventually, the entire integrated satellite. The second stage involves the turnover of the satellite from the prime contractor to the operator. During this turnover, data bases and procedures developed for manufacturing and test are typically published in manuals or delivered to the operator on electronic media. The operator then must spend time and effort

importing these products and applying additional 'ground segment constraints' for use in the operators own mission control center. While Interface Control documents help to minimize the effort required for the transfer, efficiencies can still be gained by increasing the use of common tools and standards. In an attempt to deal with these issues, European satellite operators and manufactures developed the Mission Operations Information System (MOIS). MOIS essentially provides a tool set to develop test and verification procedures and associated databases using a standard format. It allows the transfer of operations knowledge between both internal manufacturing teams as well as directly to the operators. Thus, efforts to develop and test procedures for manufacturing are directly transferable to the operator increasing the efficiency manufacturing and turnover of the satellite to the operator.

Since Monham and Quigley's article was first published in 2004, several other papers have continued to promote their approach using industry standard data bases and procedural languages. Chaudhri and Hollander⁴² built on this and extend the notion of leveraging factory test and verification procedures for use in operations by promoting the use of industry standard data bases and procedural languages to achieve these efficiencies. Example data base technology includes SQL, Oracle, XML Telemetry and Telecommand Exchange (XTCE); example procedural languages include Spacecraft Test and Operations Language (STOL); ARES - Automated Real Time Execution Suite; and Procedure Language for Users in Test and Operations (PLUTO).

Similar benefits were reported by Gilbert and van Leeuwen⁴³. In their paper, they describe the extensive ground command and control infrastructure planned to support Europe's largest contribution to the International Space Station, the Columbus Laboratory Module. The infrastructure is based on the Columbus Ground Software (CGS) originally used to perform integration and check-out of the flight hardware at the manufacturing facilities for development, simulation and software test. Twelve geographic ground operations locations are supported by CGS. The software supports the Columbus in space operations, Columbus flight control and payload operations coordination, on-site engineering support, off-site engineering support for astronaut training, and a variety of user support facilities. The primary objective for reuse of CGS is to ensure consistency between the development and operational phases. Costs are minimized by re-using data sets test procedures and models qualified during development and reducing training costs for staff.

The reuse of software to achieve commonality benefits rarely materialize to the degree planned at the beginning of a project. McKerracher⁴⁴ et al note that early estimates of 50%-70% cost savings while actual savings are only 10%-20%. Often, project managers and developers fail to consider the effort required to update requirements documents, re-write test procedures, re-perform tests, etc. McKerracher describes the 'Common Ground Approach' for developing common ground systems to support science missions. The approach begins with constraining the development of the top-level system requirements, architecture and concept of operations to ensure divergence between missions is significantly reduced. Re-use is addressed at several levels in the development process including concepts, requirements, architecture, interfaces, design, code, test plans and user guides. A product line methodology is used to align common ground effort across mission and along functional areas. Development processes were also

strictly managed. Requirements were stored in a common data base and version control was placed on commercial off the shelf and 'government off the shelf products'.

3.4 Challenges with the Application of Commonality

The benefits of commonality in terms of reduced lifecycle costs during both development and operational phases of a program are generally widely accepted. However, in a number of cases, the level of commonality declines as the program matures. Boaz and Crawley⁴⁵ describe an attribute of commonality called divergence. They attribute divergence to changing requirements; learning in development and operations; availability of new technologies; and obsolescence. For platform based products, the lack of coordination across products; intentional pursuit of point designs; misalignment between program lifecycle phases are all given as reasons for divergence. An example of a program that experience divergence was the TFX (Navy Tactical Fighter, Experimental) program in the 1960s where commonality levels dropped from 100% to contractor designs with 84% commonality, to 61% commonality and finally, to no commonality.

Chaudhri and Hollander⁴⁶ note several risks of standardizing ground data systems including increased upfront design time, timing issues between full definition of requirements versus acquisition windows and unknowns with the impact to legacy systems. Vendor reluctance to adopt new standards, lack of fully closed business case and compatibility with government acquisition processes were also listed as obstacles. Herrera⁴⁷ describes challenges with coordinating across multiple concurrent programs. A form of divergence is caused by some missions freezing baselines while common elements continue to evolve. The high level of resources required to properly staff the upfront development effort was also described as an impediment. To overcome organizational barriers with implementing commonality, Egbett and McKain⁴⁸ describe how Allison assigned an individual to be specifically responsible for ensuring and maximizing commonality across a line of turboprop and turbofan engines. Requests to deviate from commonality goals required specific approval from company senior management.

Commonality was an early goal for the International Space Station program. Ney and Looper⁴⁹ noted significant problems with achieving commonality goals due to the number of contractors involved and the lack of a program-wide system integration organization. It was believed that an integration organization with sufficient technical resources and with the proper organization authority at the program level could perform the appropriate trades between the desired degree of commonality and cost/technical performance. Other reasons considered in the Ney and Looper paper is the natural tendency for design engineers to 'take the path of least resistance' when faced with the inherent constraints that accompany commonality rules. While individual exceptions seem insignificant, it is often the case that an entire program diverges from commonality driven by the program manager's responsibility to stay on cost and schedule.

The Ground Systems Architecture Working Group is a partnership of international developers and operators of scientific and commercial satellites. The primary goal of the working group is to share lessons learned regarding the development of software systems used to manufacture and operate satellites. The eleventh working group meeting conducted in 2007 was devoted to addressing the issues associated with the increasing standardization and commonality of ground systems (software) to reduce overall lifecycle costs. Challenges reported with achieving

software commonality and new standards to increase interoperability were reported by Nadel⁵⁰. The development of common software and new standards were shown to in fact reduce costs. However, several of the participants complained those benefiting most were follow-on programs and not the programs that originally funded the efforts thus limiting many program managers willingness to participate. Vendors complained that forcing commonality of software removes a competitive advantage that their proprietary solutions offer. Furthermore, vendors argued that clear business cases must be proven prior to investing in the development of new products based on new standards. Organizations such as CCSDS, ANSI, ISO, AIAA, and several government space agencies are contributing to the proliferation of numerous standards for space systems leading to confusion among software vendors as to which standards to support. Life cycles for satellite systems often exceed 12 years forcing new standards to provide some forms of backward compatibility to support legacy systems. The participants at the workshop also commented on the need for metrics to measure the benefits of commonality and standardization in order to convince management to support these efforts.

3.5 Literature Review Summary

Commonality for spacecraft systems is focused almost entirely on flight hardware with the objective of optimizing the number of spares to reduce mass, reduce volume and increase and probability of mission success. Very few papers were found that specifically address commonality as applied to ground systems and none were found that specifically address commonality of ground systems at launch sites. The emphasis in literature with respect to ground systems is on software re-use in command, control and data distribution systems for satellites and in one case, an element of the international space station. There is no mention of other ground systems commonality for mechanical systems such as transportation and handling equipment, avionics test equipment or propellant servicing equipment. The gap in literature suggests several opportunities to study the application of commonality at the launch site in previous and current space flight programs.

4 Commonality Assessment Framework

In this chapter, a Commonality Assessment Framework is presented to compare the application of commonality across human spaceflight programs at KSC including Apollo, Space Shuttle, International Space Station and the early phases of Constellation.

The Launch Services Program is also located at KSC. As the name of the program implies, it purchases a 'service' specifically to deliver a satellite to a particular orbit or interplanetary trajectory via launch vehicles such as the Atlas V, Delta IV, Pegasus, etc. The program does not purchase or assume ownership of launch vehicle hardware and is not responsible for developing spacecraft ground systems. It does maintain a real-time data monitoring and distribution systems that provides the capability to monitor the status of the launch vehicle and spacecraft for all missions with very few changes. Ground Systems used to support the Launch Services Program are not addressed in this paper.

The areas addressed by the framework are listed below:

- Management and Planning
 - Policy
 - Process
 - Timing
 - Contracts
 - Organization
- Levels of Commonality
 - Between programs
 - Between projects
 - Between elements within projects
 - Between subsystems within elements
- Types of Commonality
 - Operational
 - Technology
 - Design

4.1 Management and Planning

An important component of a successful effort to apply commonality is timely program and project management support. Program and project leadership establish expectations through policy and processes. Key questions regarding management and planning are listed below. Sub bullets are valid responses.

- Policy: Was commonality required by the program and/or projects?
 - Yes - Commonality Documents were found
 - No - Commonality Documents not found
- Process: Was there a specific process developed to govern and/or assess commonality?
 - Yes: Documented processes were found

- No: No document processes were found
- Timing: If commonality was required, when was the policy imposed relative to the program/project lifecycle?
 - Program Formulation
 - Project Requirements
 - Project Design
 - Project Implementation
- Contracts: Was language contained in the contract to support commonality initiatives or comply with KSC design standards (key enabler for commonality between flight and ground system projects)?
 - Yes - Language was found in contracts
 - No - No Language was not found in contracts
- Organization: Did the structure of the development organization promote or hinder commonality?
 - Promote
 - Hinder

In order fully recognize the effects policy, process and timing play on the implementation of commonality at KSC, it is important to understand the nature of NASA 'programs', how 'programs' decompose into 'projects', and the typical NASA program/project lifecycle. Complete definitions and additional details are contained in NPR 7120.5D NASA Space Flight Program and Project Management Requirements and the NASA System Engineering Handbook NASA/SP-2007-6105 Rev1. A 'tailored' view of the NASA program/project lifecycle from the perspective of the launch site is also provided.

- Program: NPR 71205.D defines multiple types of programs: tightly coupled (e.g. Space Shuttle); single-project programs (James Webb Space Telescope); loosely coupled programs (e.g. Mars Exploration Program) and Uncouple Programs (e.g. Discovery Program). Human spaceflight programs are tightly coupled and are composed of multiple projects that perform a single or multiple missions. The mission or missions can not be completed by any single project. Apollo, Space Shuttle, International Space Station and Constellation are all examples of tightly coupled programs. Projects within the Program are often managed at the center level. Programs typically last several years or even decades costing hundred of millions to tens of billions of dollars. The number of government and contractor personnel involved in Programs often exceeds several thousand.
- Project: Delivers a specific capability to support missions defined by the program. Projects have their own requirements, lifecycle, budget, schedule, etc. Examples of projects with the Constellation Program include Orion (Crew Exploration Vehicle), Ares (Crew Launch Vehicle), Ground Operations and Mission Operations. DDTE for major project elements such as the Constellation Crew Exploration Vehicle typically are planned to last 5-10 years and costing hundred of millions to several billion of dollars. Number of government and contractor personnel involved in projects often exceeds several hundred. The first phase of the Constellation program is called 'Initial Capability' includes the development of the Ares I Crew Launch Vehicle, Orion Crew

Exploration Vehicle, EVA Systems and Ground Systems to support crew transport to and from the International Space Station.

Program and Project lifecycles are divided into two phases; formulation and implementation. As shown by Figure 48, both periods are further decomposed into sub-phases. During formulation, concept studies are performed to establish mission goals and objectives and high level architecture. The architecture typically determines how to decompose the Program into projects. Program requirements are allocated to the projects followed by initiating the design process. Technology gap assessments are also performed based on design concepts at the project level. Discrete technology development projects are initiated and completed during this phase to allow insertion into detailed designs that occur later in the project lifecycle. For projects, the formulation phase typically ends at Preliminary Design (PDR). The Approval milestone shown in the lifecycle Figures signifies that the project has achieved the necessary design maturity to proceed to implementation within acceptable risk levels for technical, cost and budget. A Program typically will not proceed past formulation until at least one project is ready to enter the implementation phase.

Implementation begins with phase D and includes system, subsystem and component detailed design is completed followed fabrication, system assembly, integration and test. According to the project lifecycle model, Phase D ends with launch and the Operation and Sustainment Phase E begins. The lifecycle ends with program/project closeout in Phase F.

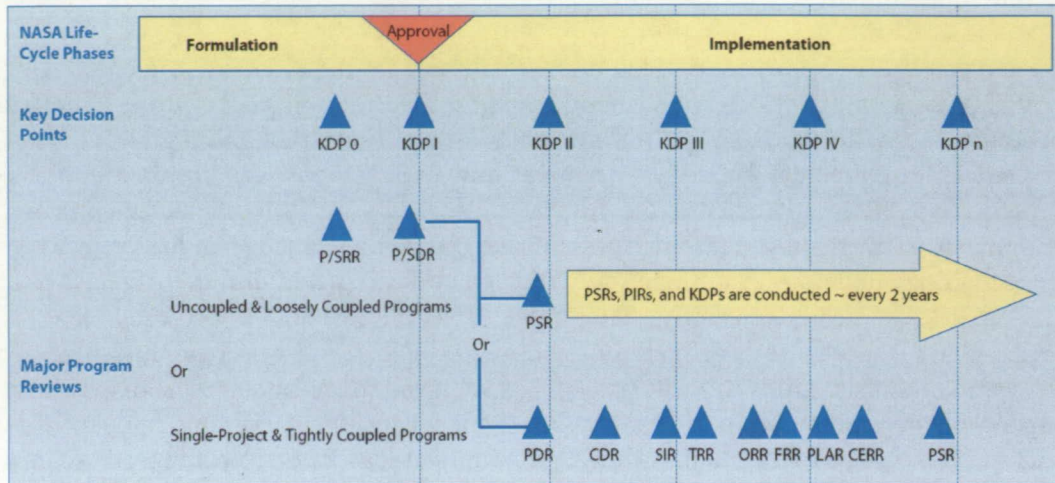

- | | | | |
|------|----------------------------------|-------|------------------------------------|
| CDR | Critical Design Review | PLAR | Post-Launch Assessment Review |
| CERR | Critical Events Readiness Review | PRR | Production Readiness Review |
| DR | Decommissioning Review | P/SDR | Program/System Definition Review |
| FRR | Flight Readiness Review | P/SRR | Program/System Requirements Review |
| KDP | Key Decision Point | PSR | Program Status Review |
| MCR | Mission Concept Review | SAR | System Acceptance Review |
| MDR | Mission Definition Review | SDR | System Definition Review |
| ORR | Operational Readiness Review | SIR | System Integration Review |
| PDR | Preliminary Design Review | SRR | System Requirements Review |
| PFAR | Post-Flight Assessment Review | TRR | Test Readiness Review |
| PIR | Program Implementation Review | | |

Figure 48: NASA Program Life Cycle⁵¹

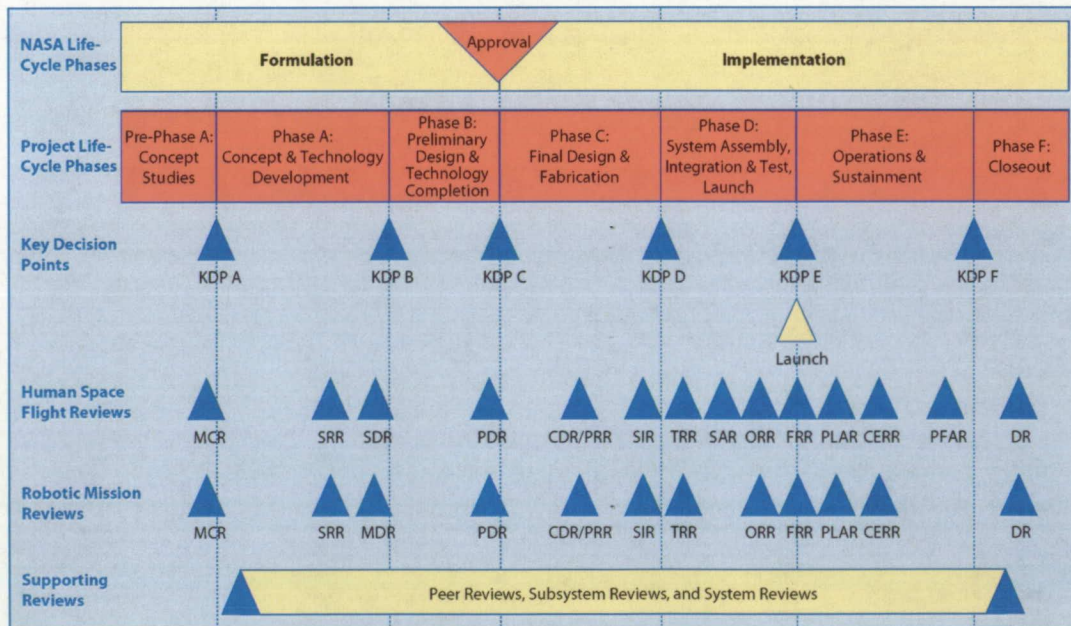

Figure 49: NASA Project Life Cycle⁵²

From a ground operations perspective at the launch site, the operations phase begins as soon as the first flight hardware elements arrive at the launch site and continues through the final launch of the Program. An alternate view of the project lifecycle is shown below.

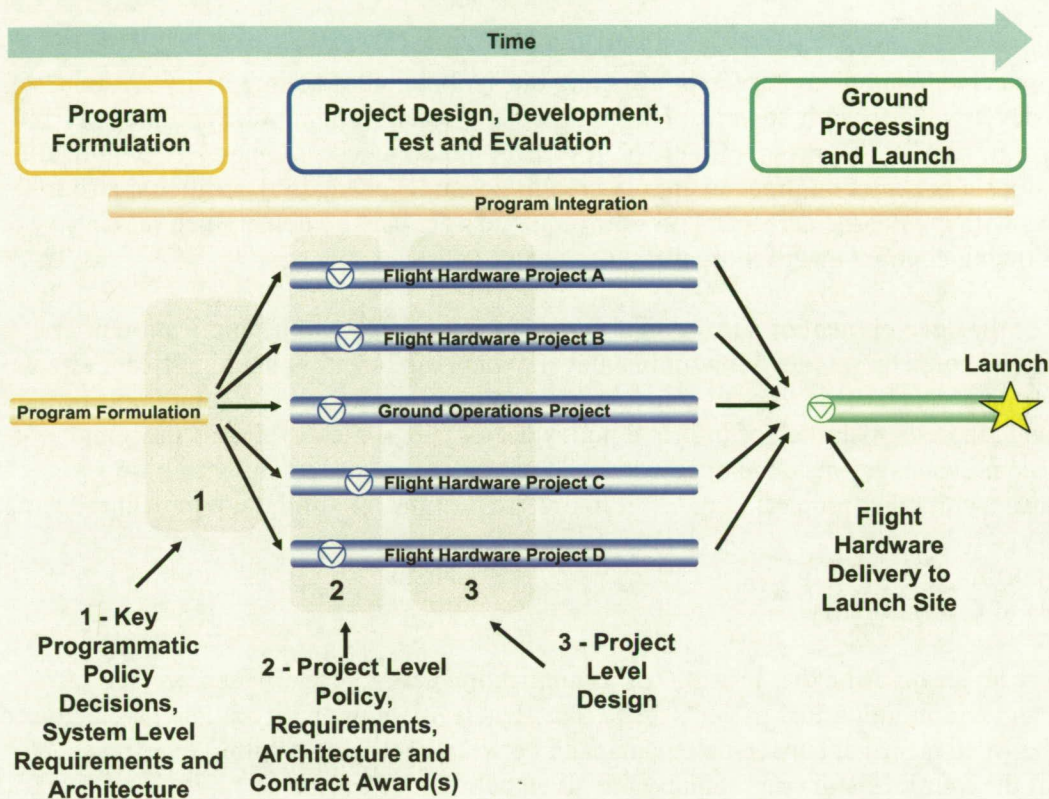

Figure 50: Alternate View of Program/Project Lifecycle

During program formulation, leadership positions are filled such as the program manager, systems engineering and integration manager, project controls manager, etc. As the architecture is matured and project elements are identified, project managers are named and project organizations are stood up to further refine the architecture and assist in developing the system-level requirements. In addition to architecture studies, key policy decisions are made during the program formulation phase shown by gray box '1' in Figure 50. Policy decisions are included in program-wide plans such as the Systems Engineering Management Plan, Program Requirements Engineering Management Plan, etc. The decision as to whether or not to apply program-wide commonality is also made during this period. Following the initial program formulation phase, the projects begin development concurrently by writing their respective concept operations and requirements. Policy decisions regarding commonality at the project-level are made early in the development cycle (gray box 2). Depending on the acquisition strategy for a particular project, a single ('prime') contract or multiple contracts may be awarded develop flight hardware and ground systems. It is important to note that contract award may occur before or after of project-level requirements are base-lined. Depending on policy decisions made at the program and

project levels, commonality may or may not be considered during design (grey box 3). Near the end of the DDTE phase, the first sets of flight hardware are delivered to KSC for ground processing and launch. For Constellation, test flights are planned for Ares I and Orion prior to declaring the system operational. To simplify the drawing in Figure 50, only one launch is shown.

Another management and planning factor affecting the application of commonality are contracts awarded to develop the flight hardware. The contract language should require and incentivize the contractor to support any programmatic policy effort including commonality. Commonality policy decisions made after contract award may require contract changes at additional cost to the program. As with most large aerospace programs, budgets are usually constrained making changes following contract award more difficult.

The design of the development organization also may have an effect on the application of commonality. Often, communication within a development organization has significant effects on the 'general approach' used to design and develop complex systems. The communication in effect results in the establishment of informal policy used by multiple developers designing different systems. Subsystems developed within a tight project environment with little communication with other projects may result in diverse designs for similar equipment reducing commonality.

4.2 Levels of Commonality

Commonality levels describe the 'breadth' of its application across program and project boundaries and within individual projects. The four levels of commonality studied are between programs; between projects; between elements; and between subsystems within elements. Examples of the four levels of commonality are given below.

- Between programs: Shuttle and Constellation
- Between projects: Ground Operations Project and Orion Project
- Between elements within projects: Ground Operations Mobile Launcher Element and Launch Pad Element
- Between subsystems within elements: Common operating systems across work stations.

4.3 Type of Commonality

For the ground systems assessment, a subset of commonality types defined by Hofstetter et al will be used:

- Operational: Similar operational procedures used to perform the same internal functions.
 - Fueling operations, transportation and handling
 - Lifting operations
- Technology: Objects leveraging off same technology used in different stages of ground processing
 - Fluid Systems
 - Command and Control Systems

- Design: Engineering designs are reused to create more than one instantiation of the object
 - J2X engines planned for use on both the Ares I and Ares V launch vehicles
 - Common parts used in ground systems

The following types of commonality defined by Hofstetter et al will not be specifically studied.

- Reusability: Objects are re-used to perform multiple missions
- Functional: Two objects perform same function internal and external function with different form
- Multi-functionality: Same Object used to perform distinctly different functions

The differences between the four programs studied with respect to reusability and functionality were determined to be negligible. This is certainly not to imply a relative lack of importance. Reusability is inherent in the design of ground systems at the launch site. They are designed to support multiple missions in many cases, and different phases of ground processing. For example, the Shuttle Mobile Launch Platform is used for integrated vehicle operations in VAB and launch operations at the Pad. Thus reusability is essential property of ground systems given the high replacement costs ground systems. Significant examples of multi-functionality were not observed in any of the four programs.

5 Application of Commonality at the Launch Site

As previously stated in Chapter 3, the literature review did not yield any specific papers regarding commonality at the launch site. Information regarding the degree to which commonality was applied during the Apollo, Shuttle and ISS programs at KSC is largely unknown and unpublished. The purpose of this chapter is to capture what was or was not done by providing specific examples of commonality and processes used to achieve commonality when available.

Research Approach

- Historical documents including letters, photographs and presentations were retrieved from NASA archives and existing program data bases
- Walk-downs of facilities and high level inspections of ground systems were performed
- Discussions were conducted with over 30 subject-matter experts involved with the development and operation of facilities and ground systems at the KSC during Apollo, Shuttle, Space Station Freedom, ISS and Constellation Programs. The subject matter experts contacted for this chapter are listed in the acknowledgements of this paper.

5.1 Apollo Program

The development of the Saturn V launch vehicle and the Apollo spacecraft was arguably one of the most ambitious programs of the 20th century. Comparatively speaking, program and project management techniques of the time were still immature compared to current best practices. Very little information was found regarding program and project management policy with respect to the launch site. No specific policies regarding commonality were found in searches of KSC archives and nor in discussions with personnel involved in the actual development of the ground systems. However, engineers working at KSC did recall many problems with the significant amount of GSE early in the Apollo Program. The number of total GSE and support equipment at KSC for the Spacecraft and launch vehicle was over 34,000 items⁵³. This issue was also noted by Tom Kelly, the Grumman Apollo Lunar Module Project Engineer, in his book Moon Lander: How we developed the Apollo Lunar Module. As early as the proposal evaluations in 1962, NASA severely criticized Grumman's plan for Ground Support Equipment (GSE) as "poorly conceived, grossly under estimated". Kelly later remarked in 1965:

... the estimated number of required drawings increased by 100s a week. ...biggest unknown was for ground support equipment. ... To me the GSE looked like a bottomless pit which we were becoming hopelessly mired.

Beginning in 1965 the estimate for engineering drawings for the Lunar Module grew from a few thousand to over 50 thousand (more than 10 thousand were for GSE)⁵⁴. By mid-way into the Lunar Module Project, hundreds of GSE items were identified. A recent 2006 historical study of Lunar Module processing at KSC identified dozens of unique specialized test and check-out equipment elements (rendezvous radar, landing radar, pyrotechnics, helium-hydrogen mass spectrometer leak detectors, etc.); 28 types of servicing equipment (RCS oxidizer servicing unit,

oxidizer transfer and conditioning units); and greater than 20 types of Handling Equipment and Fixtures (polarity fixture, transporters, slings, work stands, etc.)⁵⁵. With schedule concerns mounting, a review led by Wesley Hjernevik implied the use of commonality to address these problems and recommended the following:

...Grumman off-load its internal GSE workload by purchasing GSE end items from companies such as General Electric, North American, and McDonnell, which were already producing similar GSE units for the Apollo and Gemini programs that could be redesigned or modified for LM⁵⁶.

Due largely to problems reported by both Apollo spacecraft manufactures, the program decided that ground support equipment (GSE) would be standardized as much as possible across the program, with common units supporting both the CSM and LM. The responsibility for GSE and site readiness was assigned to an organization within the Apollo Spacecraft Program Office. This organization exercised GSE management control over the two prime spacecraft contractors. The GSE provided the capability for vehicle test and checkout at the factories, development centers, and launch sites; ensuring operationally ready facilities and support equipment for each site/facility/vehicle combination. The GSE systems were designed to support similar vehicle test requirements and procedures at the various checkout facilities and thus provided the capability to obtain a close correlation of test data and to interchange GSE units among facilities. Ground support equipment end-item design was standardized to reduce the number of different units; the GSE manufacturing time; and GSE test time. This type of GSE was referred to as 'Common Use Equipment' and was divided into three categories:

- Category A-1: Equipment was unmodified hardware that fulfilled the requirements of more than one contractor. The developing contractor operated the hardware and maintained configuration control.
- Category A-2: Equipment was the same as category A-1 equipment except that the using contractor operated it. Modifications were fabricated by the developing contractor and installed by the user.
- Category A-3: Equipment designed for multiple applications. Modifications to the original designs were necessary for specific uses. The using contractor had total responsibility for the hardware⁵⁷.

Standardization of the GSE allowed a reduction in the number of spare parts required and in the operating personnel training requirements. Furthermore, the GSE system-standardization approach permitted maximum use of GSE units among checkout facilities and assisted in meeting the Apollo schedules⁵⁸. Thus, there is some evidence of a program policy and project-level commonality between Command Service Module and Lunar Module projects. There is also evidence of several types of commonality with GSE including operational, technology, design and reusability given that duplicate sets of GSE were used to support the two spacecraft.

A prime example of the application of commonality was Automated Check-out Equipment (ACE). During the check-out and launch operations of the Mercury spacecraft, approximately 100 measurements were monitored via telemetry. As early as 1961, the number of measurements required for the Apollo spacecraft were predicted to be over 2000. Manually

monitoring every measurement during critical tests was simply not feasible. Engineers from the Preflight Operations Division at the launch site proposed the development of 'Automated Check-out Equipment' based on the latest computers available at the time. ACE was to be developed by the General Electric, the Apollo Integration Contractor. The proposal went all the way to NASA headquarters and was approved over the objections the CSM prime contractor (North American Aviation) who planned to develop their own systems⁵⁹.

ACE provided the capability for automatic, semiautomatic, or manually controlled prelaunch testing of the Apollo Command and Service Modules (CSM) and Lunar Module (LM). It could produce test commands and stimuli, monitoring spacecraft subsystem performance, conversion and processing of data, measurement of subsystem responses to test stimuli, diagnostic testing, and enabling communication between the spacecraft and engineering personnel. The ACE consisted of a Ground Station, Carry-On Equipment, and Peripheral Equipment. The Carry-on equipment (literally brought on-board the spacecraft) provided the special interfaces required to communicate to unique CSM and LM subsystems. The Peripheral Equipment allowed the Ground Station to communicate to the CSM and LM GSE⁶⁰. A total of 14 ACE Ground Stations were installed in factory facilities at North American Aviation plant in Downey, CA, the Grumman plant in Bethpage, NY, Manned Spacecraft Center (renamed the Johnson Space Center in 1973) in Houston and at KSC⁶¹.



Figure 51: Astronauts and Ground Ops Crew in ACE Control Room in the O&C [NASA]

The Automated Check-out Equipment (ACE) is one of the best examples of commonality between elements within the Ground Operations at KSC, as well as between projects within the Apollo Program. It was used to support factory test, offline spacecraft operations, integrated operations in the VAB and pre-launch operations at the launch pad. Thus multiple commonality types were exhibited including between projects (CSM/LM and Ground Operations) and between elements within a project (off-line ground operations and integrated operations).

One key enabler was existence of the Integration Contractor. Apollo required the coordination of dozens of contractors and government agencies. NASA headquarters recognized this issue early in the program and proposed the addition of a new integration contractor. The idea was almost universally rejected by the prime contractors who opposed having competitors oversee their own work as well as the centers (including KSC) who believed the integration contractor's responsibilities overlapped with their own. General Electric was ultimately hired in 1962 and performed three functions: develop check-out equipment for launch operations (ACE), assess launch vehicle and spacecraft reliability and to performed an integration role⁶². Relative to the overall program/project lifecycle, the decision to hire the integration contractor and use ACE occurred after the prime contracts were awarded to North American Aviation, Grumman, Boeing, Chrysler, etc. Without the leadership demonstrated by the Washington-based program management team, it is unlikely that benefits having essentially only one check-out system for the spacecraft would have been realized.

Despite the efforts to standardize GSE noted by Kelly and Jenkins et al, personnel at KSC involved in Apollo Ground Operations recalled multiple instances where GSE designed by the spacecraft OEM simply did not function at KSC. Examples include fluid servicing carts and special electronics test equipment. Problems were attributed to the unique environment at KSC such as frequent lightning storms; power surges; corrosive salt air environment; and unusual servicing configurations such as having to pump commodities up several hundred feet from the base of the mobile launcher to the spacecraft. In many cases, problematic GSE provide by the OEM had to be discarded and replaced by systems development at the launch site thus limiting the commonality benefit.

Organizational issues were also noted as a contributing factor to the lack of commonality at the launch site. Access and services to the Saturn V and Apollo Spacecraft were provided by nine swing arms attached to the launch umbilical tower. The swing arms were attached to the Apollo Launch Umbilical Tower and initially, were treated as discrete projects. Personnel representing each engineering discipline reported directly to each swing arm project manager. Each swing arm project had its own structures engineer, fluids engineer, electrical engineer, etc. As the design for the swing arms progressed, personnel at the launch site who ultimately would have to operate and maintain the swing arms noted significant differences in the design and parts used for each arm. The lack of commonality between the swing arms was attributed to the lack of communication between engineering personnel in the same discipline working on different projects. In the case of swing arm design, one engineer recalled the following:

The Launcher Accessories groups were organized on a product basis - Hold down Arms, Swing Arms, Tail Service Masts, etc. As such, each group was self-sufficient with electrical and mechanical engineers together in each group. Imagine how commonality

was attained with this organization. There was none. As such, there were no common electrical design rules, components, parts, or documentation seen in the designs. This was soon changed by encouragement from the launch operations engineers as the differences in design approach, documentation and components were difficult to contend with at the launch site. We Op's folks finally convinced the manager of the Launcher Accessories Group to become skill-oriented instead of product-oriented and we began seeing commonality of documentation, parts and components and common logic within the designs. It did not happen overnight.

An Electrical Systems Branch was formed and needed specifications and standards were written that included the "what" as well as the "how" in order to establish a common design approach. MSFC had a well organized components group that acquired, tested and specified electrical components and parts for use in ground support and servicing equipment that both MSFC and KSC then used. These items included relays, power contactors, wire, cable, connectors, fasteners, chassis slides, and a packaging standard that provided selected sizes for front panels, rear chassis sizes and console/panel colors.

The problems with lack of commonality with parts and designs at the launch site eventually led to formal KSC Specifications and Standards for Design and Fabrication of Ground Support Equipment used for subsequent programs.

It is also important to note the reuse of existing infrastructure. In addition to proximity to the south east coast of the United States, some of the primary reasons for locating the Apollo Launch Systems on the lands to the north and west of Cape Canaveral Air Force Station were the availability of existing infrastructure such as roads, bridges, airports, seaports, railways and existing range tracking and communications systems. The following table summarizes commonalty findings for ground systems developed for the Apollo Program.

Table 3: Apollo Ground Systems Commonality Summary

Apollo Ground Systems Commonality Summary		
Management and Planning		
Program Wide Policy	No	No policy documents were found. However, decision to use ACE at spacecraft manufacturing facilities, KSC and JSC required a programmatic directive.
Project Wide Policy	No	No ground operations policy documents were found. Discussions with personnel who developed ground systems at KSC did not remember any specific policy directives.
Timing	Project Design	Decision to use ACE was made following CSM and LM contract awards.
Contracts	No	Problems with LM GSE and subsequent push to leverage of CSM GSE implied potential scope changes in Grumman LM project. No actual contractual documents were located indicating changes.
Organization	Hindered	Each Swing Arm on the Launch Umbilical Tower was designed by a different organization resulting in a large diversity of designs and parts.
Levels of Commonality		
Between Programs	Yes	In terms of infrastructure, range assets as well as roads, rail ways, runways, etc were reused. However, from a purely ground systems perspective, no evidence of commonality between programs was found. All ground systems including Facilities, GSE and SE were developed specifically for Apollo.
Between Projects	Yes	ACE was the best example of Ground Systems used between projects (Ground Operations, Mission Operations, Command/Service Module, and Lunar Module). A number of specific items of GSE were identified in recent Apollo spacecraft whitepapers. However, it could not be determined with certainty if the same GSE or GSE design was used between the CSM and LM or for offline operations between the different stages on the Saturn V.
Between Elements within Ground Operations Project	Yes	Design documentation required to perform this level of assessment was not available. However, it can be argued that the Mobile Launch Platform/Launch Umbilical Tower and Crawler Transporter are examples of commonality between elements (Integrated Operations Ground Systems and Launch Operations Ground Systems).
Between Subsystems within Ground System Elements	Indeterminate	Design documentation required to perform this level of assessment was not available.
Types of Commonality		
Operational	Yes	While the specific test procedures for CSM and LM check-out were different, the user interface to ACE was essentially the same allowing workers to support the check-out of types of spacecraft.
Technology	Yes	Establishment of electrical common parts for use in multiple GSE systems.
Design	Indeterminate	It is believed that this type of commonality did exist. However, design documentation required to perform this level of assessment was not available.

5.2 Space Shuttle Program

The desire to reduce the costs of space transportation was probably the most important factor leading to the development of the Space Shuttle. In 1969, President Nixon's Space Task Group indentified the need to lower the cost of space transportation in order to allow frequent servicing of a new orbiting space station:

Exploration and exploitation of space is costly with our current generation of expendable launch vehicles and spacecraft systems. This is particularly true for the manned flight program. Recovery and launch costs will become an even more significant factor when multiple re-visit and resupply missions to on Earth orbiting space station are contemplated. Future developments should emphasize:

Commonality - the use of a few major systems for a wide variety of missions.

Reusability - the use of the same system over a long period for a number of missions.

Economy - far example, the reduction in the number of "throw away" elements in any mission; the reduction in the number of new developments required; the development of new program principles that capitalize on such capabilities as man-tending of space facilities; and the commitment to simplification of space hardware.

Later in the report, the Space Task Group specifically recommended the following:

...develop new systems and technology for space operations with emphasis upon the critical factors of: (1) commonality, (2) reusability, and (3) economy, through a program directed initially toward development of a new space transportation capability and space station modules which utilize this new capability⁶³.

Thus, prior to the formal approval of the Space Shuttle Program in 1970, the value of commonality was established at the highest levels. Concepts for the development of the ground systems began immediately.

Eager to meet the critical objectives outlined the Space Task Group; KSC suggested the development of a common control system for use across the Shuttle Program. While the Apollo ACE system was indeed an excellent example of commonality used program-wide for factory and offline spacecraft checkout, there were still a total of three unique control systems developed for use at each of the manned spaceflight centers (KSC, JSC and MSFC). In a letter written in 1970 by KSC Center Director Kurt Debus to Associate Administrator Dale Myers, Debus attributed the development of three systems to the following:

KSC's role in ground support equipment and flight hardware design has been primarily that of a consultant, providing inputs to the development centers [JSC and MSFC]. As a result, two problems have occurred: first, hardware design has not sufficiently recognized the operational requirements of assembly, check-out and launch; and second, all three MSF Centers have developed separate checkout and data systems, with

subsequent duplication of hardware. ... The Space Task Group used the key words of commonality, reusability, and economy. These words should apply to ground systems also.⁶⁴

Debus expanded his proposal to include the development of all GSE to be used at the launch site in a follow-up letter to Meyers in 1971. He proposed to produce a total systems concept at minimum cost. This will include integration of the ground systems and equipment, maximize commonality and reusability⁶⁵. The benefits of commonality were recognized early in the Shuttle Program at the launch site by KSC senior management.

In an early report written in 1971 on requirements for ground support and facility requirements, processing flows were developed for both horizontal and vertical take-off versions of the Shuttle as shown below in Figure 52. At the time of this report, the final configuration of the Space Shuttle System was not yet established. The report refers to two vehicles: a reusable liquid flyback booster and orbiter. The final configuration of the Space Shuttle eventually evolved to the orbiter, external tank and twin solid rocket boosters.

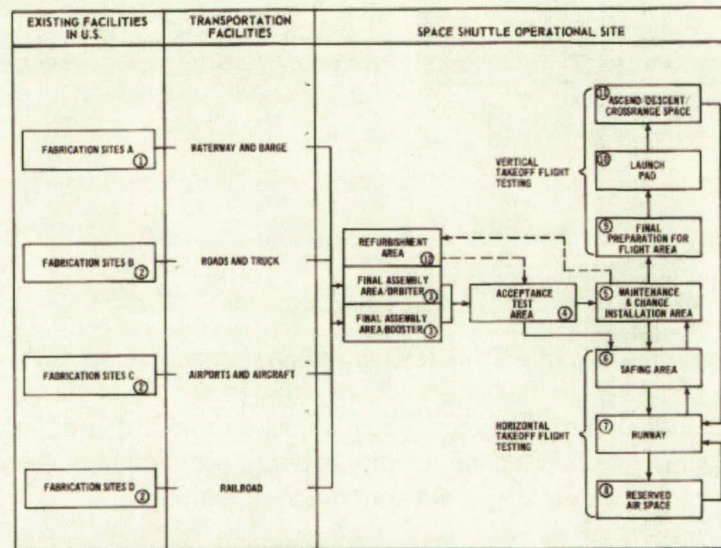

Figure 52: Early Shuttle Ground Processing Flow Concept⁶⁶

The processing flows were used to perform a systematic assessment of the ground systems required to process the Shuttle at the launch site. An example from the report is shown below:

Equipment Flow →

Equipment	E Main Stabilizer(s)						H Install and Rig Avionics Center Surfaces						I Install Covers and Cranes						J Substrate Acceptance Tests						K Install Vehicle in Test Facility Rig; Perform Structural Loading and Calibration Tests						L Airframe Dynamic Response Tests										
	0	01	02	03	04	05	1	11	12	13	14	15	2	21	22	23	24	25	3	31	32	33	34	35	4	41	42	43	44	45	5	51	52	53	54	55					
MAINTENANCE EQUIPMENT																																									
Adjustable Engine Installation Fixture																																									
Alignment Fixture	3						3					2																													
Alignment Rig	3						3					2																													
Block Engine Installation Fixture																																									
POSITIONING EQUIPMENT																																									
Hydraulic Lift																																									
Support	2																																								
Support Engine Work Stand																																									
Crane Jack																																									
Slings	3						3					2																													
Slings and Fixing																																									
Slings and Fixing																																									
TRANSPORT EQUIPMENT																																									
Adjustable Engine Dolly																																									
Skid Bar	3						3																																		
Roller																																									
Roller Engine Body																																									
Rolling Fixture																																									
Transporter	3						3					2																													
Truck	3						3					3																													
STRUCTURAL LOADING TEST EQUIPMENT																																									
Structural Test Equipment																																									
Special Power Supply																																									
ACCEPTANCE AND SYSTEMS INTEGRATION TEST EQUIPMENT																																									
Acceptance Engine Checkout Equipment																																									
Acceptance Alignment Equipment	3						3					2																													
CCU Units and Air Conditioning																																									
Control, Pressure, and Pump Equipment																																									
Ground Auxiliary Power Unit																																									
Ground Control System																																									
Integrated Test and Monitor System																																									
LRU Test Equipment																																									
Control Mapping Fix																																									
EC Checklist Equipment																																									
Roller Engine Checkout Equipment																																									
Structural Test Equipment																																									
OPERATIONS EQUIPMENT																																									
Jet Engine Starter																																									
Jet Engine Fueler																																									
Portable Power Unit																																									
Tire and Wheel Handling Equip																																									
Tire Mounting and Removing Fixture																																									
Wheel Chuck																																									
GENERAL GSE																																									
Access Stand																																									
Adjustable Engine Work Stand																																									
Compressor Air																																									
Flare Light																																									
Hydraulic Services																																									
Industrial Power																																									
Intercommunications System																																									
Support Engine Work Stand																																									
Tools																																									

* Required until completion of all inspections and landing gear cycle tests.
 * Only for vehicular to be used for structural flight tests.

- Legend:**
- I Flightline Assembly
 - B Rigging Assemblies and Vertical Stabilizer(s)
 - 01 Casework
 - IV Avionics Control Surfaces
 - V Avionics Engines
 - VI Rocket Engines
 - VII Detail Parts
- Notes:**
- 1. Quantity needed indicated by an Arabic number, a Y for yes, or a - for undetermined.
 - 2. Items can be used for more than one function; therefore, quantity needed numbers are not always cumulative.
 - 3. If an assumed landing gear has been installed prior to delivery of knowledge to operational site.

Figure 53: Early Shuttle Ground Systems Assessment⁶⁷

The report concluded with a number of recommendations for the further definition of ground systems including seeking maximum commonality between orbiter and booster GSE and to include commonality requirements in ground system specifications.

The assessment of commonality requirements for GSE was also one of five steps included in an early proposal for the Shuttle Launch and Landing Ground Systems Acquisition Plan. Three of six Ground Systems were identified by the proposal as common both to the factory and the launch site: vendor Line Replaceable Unit (LRU) maintenance equipment; development contractor LRU and systems maintenance equipment; and common factory launch site equipment. It was recognized that not all capabilities required at the factory were needed at the launch site and that equipment destined to be used primarily at the launch site be optimized for the launch site environment. A number of additional documents located in the KSC archives clearly indicate a strong desire at the earliest stages of the Shuttle Program to utilize commonality to reduce costs at the launch site.

In 1973, the Orbiter Project Manager, Aaron Cohen, assigned responsibility of launch site GSE developed by Rockwell International Corporation to KSC. This in part realized Debus' goal of allowing KSC to more directly manage the development of ground systems destined for use at

KSC. This new authority allowed requirements unique to the KSC environment to be accounted for early in the development process of GSE.

The Space Shuttle Main Engines (SSME) were arguably one of the most complex and challenging technology development area in the Shuttle Program. The Main Propulsion Test Article (MPTA) was designed to test the Shuttle Main Engines. It consisted of all the cryogenic plumbing and electrical systems contained in the aft section of the Space Shuttle as well as non-flight Shuttle External Tank. Early in the planning for the MPTA, it was recognized that ground systems planned for KSC to control and monitor loading of the External Tank and operation of the SSMEs could be used at the Stennis Space Center as recalled by one engineer below:

During the Saturn/Apollo period the ground support systems were designed, built, installed and operated by the organization at that Center or location, e.g., Saturn SIV & SIVB was accomplished by Douglas Aircraft for all locations where the stage was to be serviced, Rockwell did the same for the Saturn SII stage, and MSFC provided for the Saturn SIC at Huntsville and again for SSC (then called MTF). This included the GSE but not the facility for the KSC locations. Our experience was not good with this approach which resulted in schedule delays, flight hardware damage when trying to service the first time, and of-course added cost to the program.

Because of the lesson learned from the above experience, the Shuttle Program accepted our recommendation to have KSC design the Shuttle vehicle MPS propellant and gases loading GSE for both KSC and the off site development site (MPTA @ SSC). This approach worked very well and saved considerable cost by deleting a dedicated facility at KSC required to activate the launch site (A dedicated facility vehicle was required to activate the launch site for the Saturn V). There was only one design required and considerable testing was accomplished at SSC developing the operational procedures and refining the design for maintaining the propellant in the flight tanks at the desired level for launch. If technical problems were encountered during the development testing at a location other than KSC, the resultant impact is less to the schedule ...

One important realization resulting from the development of ground systems for Apollo was the need for design standards at KSC. As was stated previously, personnel supporting ground operations during Apollo recalled several instances where GSE manufactured by the spacecraft OEM simply did not work in the unique operating environment of KSC. To address this, the first design standards emerged in 1970 as GP-863 *General Criteria for Design of New Equipment and Facilities to be Utilized at KSC*. In 1974, the Shuttle Program also released the first version of SW-E-0002, *Space Shuttle GSE General Design Requirements*. GP-863 later replaced in 1983 with KSC-DE-512-SM, *Facility, Systems and Equipment General Design Criteria*. The document applied to design of facilities and ground based hardware and software used to support transporting, receiving, handling, assembly, test, check-out, service, and launch of space vehicles and payloads at launch, landing and retrieval sites. The document evolved over the years and the latest revision was released in 2004. It is comprehensive and addresses a wide-range of safety and design considerations from structural design margins to fungus resistance. The document includes specific design requirements as well as referencing a broad range of KSC unique, military and commercial design standards.

The KSC and Shuttle Program specifications together-guided the development Facilities, GSE and SE. The emergence of these standards facilitated commonality through parts standardization and ensuring equipment intended to operate at the factory and at the launch site did not have to be redesigned due to the lack of understanding of the KSC environment. A good example of this is fluid and gas control panels located throughout the center. Each panel is designed in accordance to the design standards. At the lowest level, commonality was achieved at the parts level, reducing the logistics foot print required for spares and simplifying sustaining engineering requirements. The standards also ensured commonality with respect to the operator interface. The familiar look and feel of each panel enabled certain level of operations commonality reducing procedure development as wells as reducing operator errors.

Leveraging off the positive experience with the Apollo ACE system, proposals were made early in the Shuttle Program to develop a single command and control system for use KSC and JSC. KSC proposed the Launch Processing System (Chapter 2) and JSC proposed a system called Universal Test Equipment (UTE). There was considerable debate as well as sense of competition between the two proposals as one engineer involved in the early negotiations recalled:

JSC proposed a new system called UTE – Universal Test Equipment. Their “MCC” at the time was communication gear and meters. As I remember, the UTE was more of a lab control environment without the speed needed by LPS. There was little redundancy capability and limited user friendliness. There were big shootouts resulting in a management summit at JSC where the program gave KSC the go ahead for LPS. There was an ongoing race between JSC and KSC to decide who will provide the Space Shuttle ground systems for use at KSC. We pitched LPS to Bob Thompson and JSC pitched UTE. They also countered with Super UTE. Bob Thompson, Shuttle PM, decided that KSC has the launch and landing job and they should prevail.

Several LPS sets were ultimately built to support operations in the Shuttle ground processing in the OPFs, VAB, Pads and at the HMF. A set to test LPS system software and application software with Orbiter avionics was also deployed at JSC in the Shuttle Avionics Integration Laboratory. Early in the Shuttle Program, LPS sets were also installed at MSFC and later in the VAB to support offline SRB operations (AFT Skirt and Forward Skirt and Frustum refurbishment). The LPS sets at MSFC and in the VAB were decommissioned relatively early in the program and replaced with smaller and more flexible systems.

One engineer who was involved with the development of Shuttle Ground Systems also noted the effects vehicle architecture on commonality. Electrical, fluid and gas interfaces with a fully stacked Apollo-Saturn V launch vehicle required nine separate swing arms. As stated earlier in the chapter, this architecture contributed to the propagation of different GSE designs. The primary interfaces for these same services on the Space Shuttle are via two Tail Service Masts (TSMs) and a rise-off umbilical for each SRB located on the Mobile Launch Pad. The TSMs interfaces directly to the Obiter as shown in Figure 54 below. From a ground systems perspective, the Orbiter served to integrate the requirements for ground services for all three elements subsequently reducing the number of ground systems interfacing to the vehicle during

integrated operations in the VAB and at the Pad. This type architecture also drove the need for a strong systems engineering effort early in the program to ensure the ground servicing requirements for the ET, SRB and Orbiter were all satisfied via the same two TSMs.



Figure 54: One of Two Shuttle Tail Service Masts [NASA]

Note: Prior to the Challenger accident, SRB ground interfaces consisted of a single nitrogen purge line and COAX data interface that separated at T-0 with a simple rise-off umbilical. SRB joint heaters were added as part of a mitigation strategy to ensure nominal performance of the O-rings. The joint heaters required new ground power interfaces that were added to the rise-off umbilicals.

Given the decision to perform launch and landing operations between KSC, commonality between programs for infrastructure and many major ground systems was an obvious choice. A table listing some of major facilities and ground systems reused from Apollo to Shuttle is shown Table 4.

Table 4: Apollo to Shuttle Ground Systems Re-use

Apollo to Shuttle Ground Systems Re-use	
Ground System	Comments
Industrial Area Institutional Support Facilities and Infrastructure	Headquarters Building, Central Instrumentation Facility, Occupational Health Facility, Training Auditorium, warehouses and numerous other smaller facilities were all reused. Supporting infrastructure such as roads, railways, sea ports, power distribution systems, water systems, etc were also reused.
Operations and Check-out Building Astronaut Crew Quarters and High Bay	ACE, and Test stands for CSM and LM were removed. High bay utilized for early Shuttle Cargo Processing including Hubble Space Telescope and Space Lab.
Hypergolic Building and Fluid Test Complex	Renamed Hypergolic Maintenance Facility. Re-outfitted to support maintenance and check-out of the Orbiter Forward Reaction Control System and Orbital Maneuvering System Pods
Vehicle Assembly Building	High Bays 1-3 were refitted with new moveable work platforms to support stacking of the Shuttle system including SRB stacking; ET Mate and Orbiter Mate integrated testing prior to roll-out to the launch pad. High Bays 2 and 4 were re-outfitted to support offline External Tank test and check-out. Early in the Shuttle Program, SRB Aft Skirt and, Forward Skirt and Frustum refurbishment occurred in the VAB Low Bay.
Mobile Launch Platforms	All three Apollo Mobile Launchers were modified to support Shuttle. The launcher base flame ducts were reconfigured to vent the SRB and SSME exhaust. The Launch Umbilical Towers were removed from the launcher base. The top section of the tower was used for the Shuttle Fixed Service Structures on Launch Pads 39 A and B.
Crawler-Transporter	Both Crawler-Transporters were reused. No significant modifications were required to support Shuttle.
Crawler Way	Re-used with no significant modifications.
Launch Control Center	All equipment such as the RCA 110As were removed from the firing rooms. The Shuttle Launch Processing Systems was installed on the second and third floors including in all four Firing Rooms.
Launch Pads 39A and 39B	Both pads were modified to support Shuttle Launch Operations. No substantial modifications were made to the launch pad concrete structure. The shape of the Flame Deflector mobile structure was modified in shape and fixed to flame trench. New Fixed Service Structure and Rotating Service Structures were erected on the Pad Service. Hydrogen and LOX dewars were reused from Apollo.
Orbiter Processing Facilities	New for Space Shuttle Program
Assembly and Refurbishment Facility	New for Space Shuttle Program
Rotation, Processing and Surge Facility	New for Space Shuttle Program
Shuttle Landing Facility	New for Space Shuttle Program

The significant level of reuse was enabled in large part by choosing the same overall ground operations approach as Apollo – the Mobile Launch concept. Substantial cost savings were realized early in the Program, allowing resources to be correctly applied to the Shuttle's state-of-the-art technology development requirements. In general terms, commonality between the Apollo and Shuttle Programs was achieved primarily with facilities, structures, large mechanical systems and large fluid systems. All of the Apollo data acquisition and command and control systems were replaced by newer computing systems that were rapidly evolving at the time of Shuttle ground system development. It is interesting to note that reuse of the VAB and Launch Pad constrained the design of the Shuttle to some degree by the width of the VAB doors as well as the width of the flame trench. The following table summarizes commonalty findings for ground systems developed for the Space Shuttle Program.

Table 5: Space Shuttle Ground Systems Commonality Summary

Space Shuttle Ground Systems Commonality Summary		
Management and Planning		
Program Wide Policy	Yes	Commonality was directed at the highest level by the Space Task Group chartered by President Nixon.
Project Wide Policy	Yes	Emphasis on commonality appeared in several documents including letters written by KSC Center Director and reports by KSC project managers.
Timing	Program Formulation	Direction to address commonality was given by the Space Task Group prior to Space Shuttle Program approval. Early efforts to develop ground systems concepts specifically included requirements to address commonality.
Contracts	Indirectly Addressed	The flight hardware prime contracts were managed by JSC and MSFC. KSC was assigned the responsibility to oversee the design of launch site GSE developed by Rockwell International Corporation. Therefore, requirements unique to the launch site were addressed during development.
Organization	Promoted	Personnel were matrixed to ground system projects from engineering teams organized by discipline facilitating common design for similar systems across ground system projects (i.e. Mobile Launch and Launch Pad).
Levels of Commonality		
Between Programs	Yes	In terms of infrastructure, range assets as well as roads, rail ways, etc were reused. Major Ground Systems were reused between Apollo and Shuttle as described in Table 4.
Between Projects	Yes	Commonality between GSE used in the factory and the launch site was directly addressed during development. KSC developed GSE used at the MPTA was a rare example of ground systems developed for use at the launch site actually used 'upstream' in the DDTE phase of a flight hardware system (SSME).
Between Elements within Ground Operations Project	Yes	LPS Sets were deployed to multiple processing locations around the center to support offline operations in OPFs; Integrated Operations in the VAB; Launch Operations at the Pads; payload operations in the O&C then the SSPF and at the Shuttle Avionics Laboratory at JSC. Fluid System Panels were based on a common design and were in multiple locations around the center.
Between Subsystems within Ground System Elements	Yes	Subsystems within command and control systems as well as fluid systems used common designs.
Types of Commonality		
Operations	Yes	Shuttle payload processing. Similar operational procedures are used to test and check-out payloads prior to installation in Orbiter payload bay.
Technology	Yes	Establishment of common parts for electrical and fluid systems for use in multiple ground systems.
Design	Yes	Command and Control Systems and Fluid Systems

5.3 Space Station Freedom/International Space Station Program

As discussed in Chapter 2, development of the Space Station began with the Freedom Program in 1984. In 1986, the Space Station Freedom Program Office was established in Reston, Virginia to oversee the work of four NASA centers (Marshall Space Flight Center, Johnson Space Center, Lewis Research Center, and KSC) and five prime contractors (Boeing, McDonnell Douglas, Rocketdyne, Rockwell and Harris). The Lewis Research Center was renamed the Glenn Research Center in 1999. The organizational structure of the Freedom Program is shown below in Figure 55:

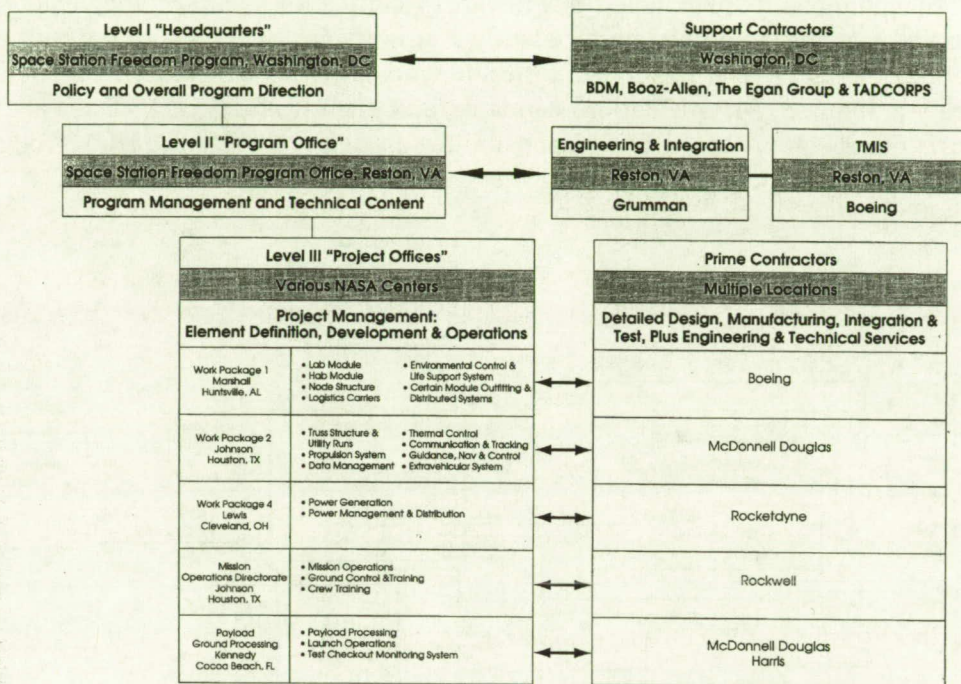

Figure 55: Space Station Freedom Program [NASA]

Figure 55 illustrates the inherent complexity of managing the technical baseline of a program as large and as complex as Freedom. To address this, NASA competed and awarded a contract to the Grumman Corporation to perform program-level systems engineering and integration across all NASA Centers, prime contractors and international partners. Payload Ground Processing was assigned to KSC.

Recognizing the potential to reduce both development and recurring life cycle costs, requirements for commonality were established early in the Program. In order to successfully implement commonality across such an organizationally diverse program, the Freedom Program instituted the Space Station Commonality Program (SSCP). In 1988, the Space Station Commonality Process Requirements was released that formally documented a program-wide approach for commonality. The document describes seven components of commonality: commonality within systems and equipment; commonality between systems and elements; commonality between the Space Shuttle Program and other NASA Programs; approval of unique

items; use of standard parts; commonality within support equipment; commonality relative to the Software Support Environment . The plan defined commonality as follows:

Commonality can be broadly defined as the use of identical, interchangeable, interoperable, functionally compatible (see the Glossary) or, at least, similar hardware, software, Support Equipment (SE), operating and training procedures, and technical design approaches across a program for satisfying different sets of functionally similar requirements.

The SSCP was comprehensive and included both flight and ground systems. The scope of the program-level commonality plan includes hardware (specifications, parts, components, subsystems and systems including interface hardware), software (specifications, designs and end products), Support Equipment, facilities/fixtures, functions, processes, procedures, operations, test/verification, training, documentation, standards, and user interfaces (e.g., displays, ergonomics). Organizational roles and responsibilities from Level I (NASA HQ) through the Level 3 Station Work Packages were managed at the centers as shown in Figure 56.

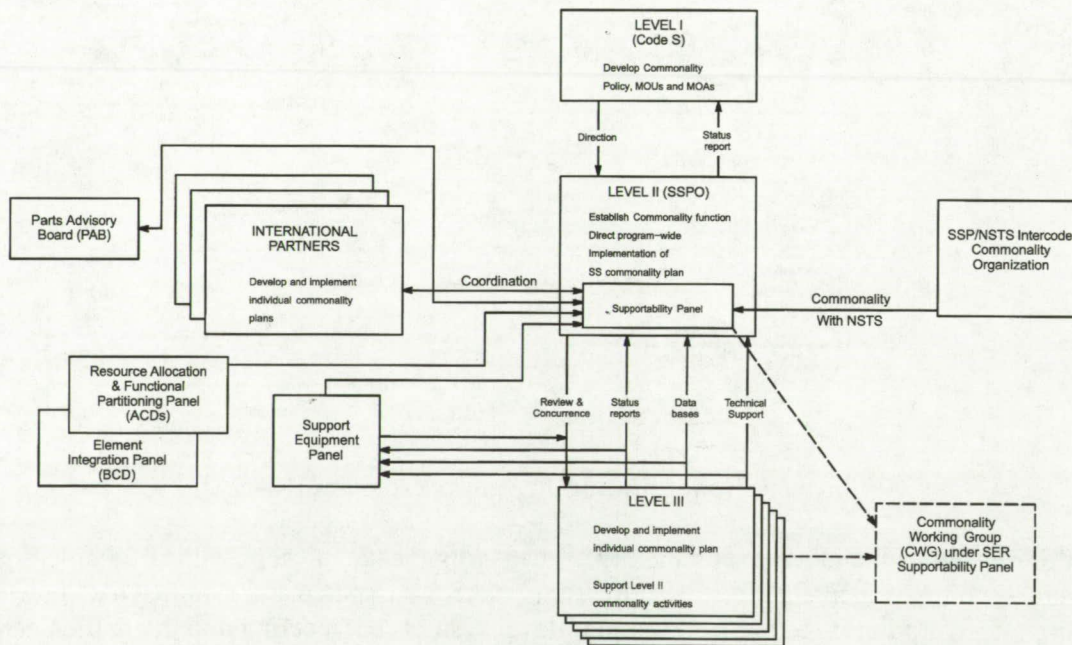

Figure 56: Space Station Commonality Program Roles and Responsibilities [NASA]

Commonality between the National Space Transportation System (NSTS - now known simply as the Space Shuttle), international partners as well as the Level III Work Packages was coordinated by the Program at Level II. Figure 56 clearly shows a closed-loop process between all stakeholders to manage and track progress of the commonality program. The document specifically requires commonality:

All SSP items shall be common unless approval has been granted to make the items unique, or unless waivers or deviations have been granted by the Systems Integration

Board (SIB)/SSCB. However, all potential commonality items shall undergo analysis using System Commonality Analysis Tool (SCAT⁶⁸) and/or other commonality analysis tools.

Detailed processes were defined to ensure accountability across the Program for commonality. Processes included the search for common functions/items; evaluation of candidate unique items and common items and the population of program-wide databases. Each Level III organization was required to develop commonality plans to comply with the SSCP. While detailed design commonality analysis was the responsibility of the work package owners at Level III, approval for unique items and non-standard parts had to be approved at Level II by the Space Station Control Board as shown in Figure 57.

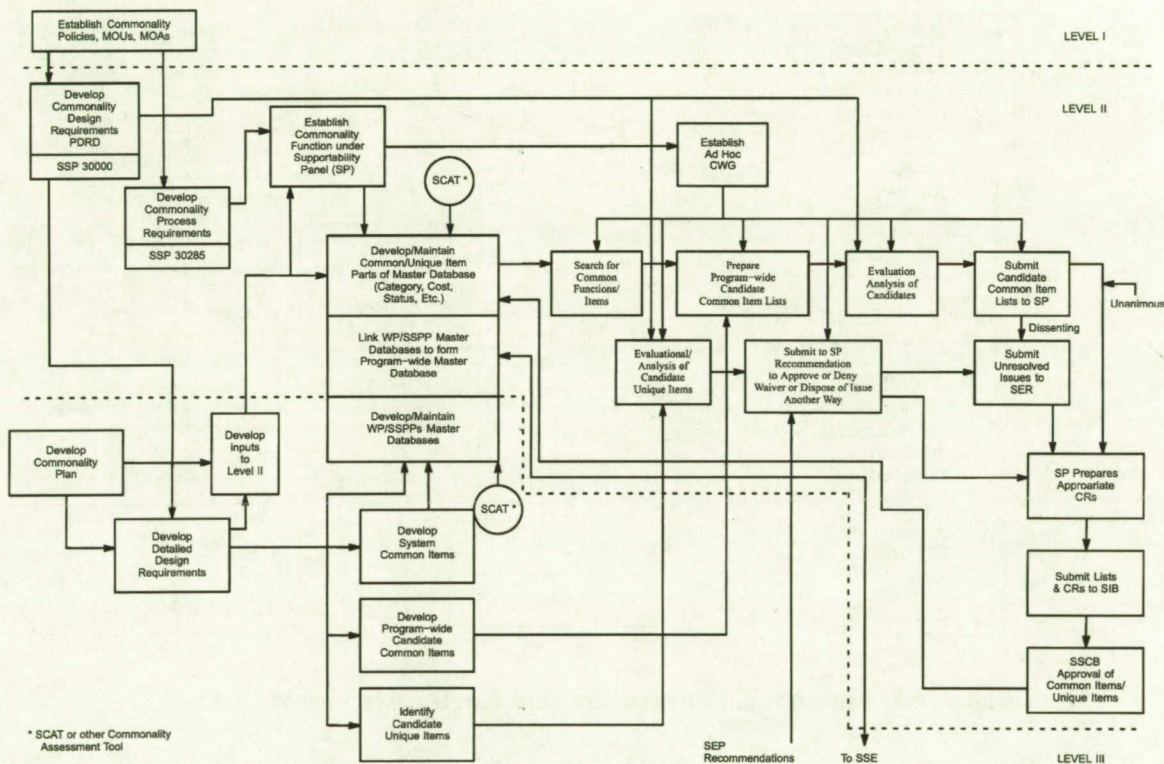

Figure 57: Space Station Program Level Commonality Process [NASA]

A number of companion documents also supported the commonality program. A partial list is shown below:

- Space Station Systems Requirements (defined commonality requirements)
- Space Station Ground Support Equipment Integration Process Requirements
- Baseline Configuration Document (list of common items)
- Space Station Approved Electrical, Electronic and Electromechanical Parts List

Space Station Freedom Commonality efforts at KSC were guided by both Program Level Commonality Plan and the Space Station Ground Support Equipment Integration Process

Requirements. The first revision of the GSE Integration Process was released in 1986 and the last revision was released in October 1993. The KSC Program GSE Management Office was assigned by Level II to manage and integrate all Space Station Program GSE. In this role, the KSC developed and maintained the Support Equipment Data Base; led GSE trade studies and commonality analysis; recommend acquisition strategies; and provide program tracking and status of GSE. The System Engineering Flow Diagram for Support Equipment is shown in Figure 58.

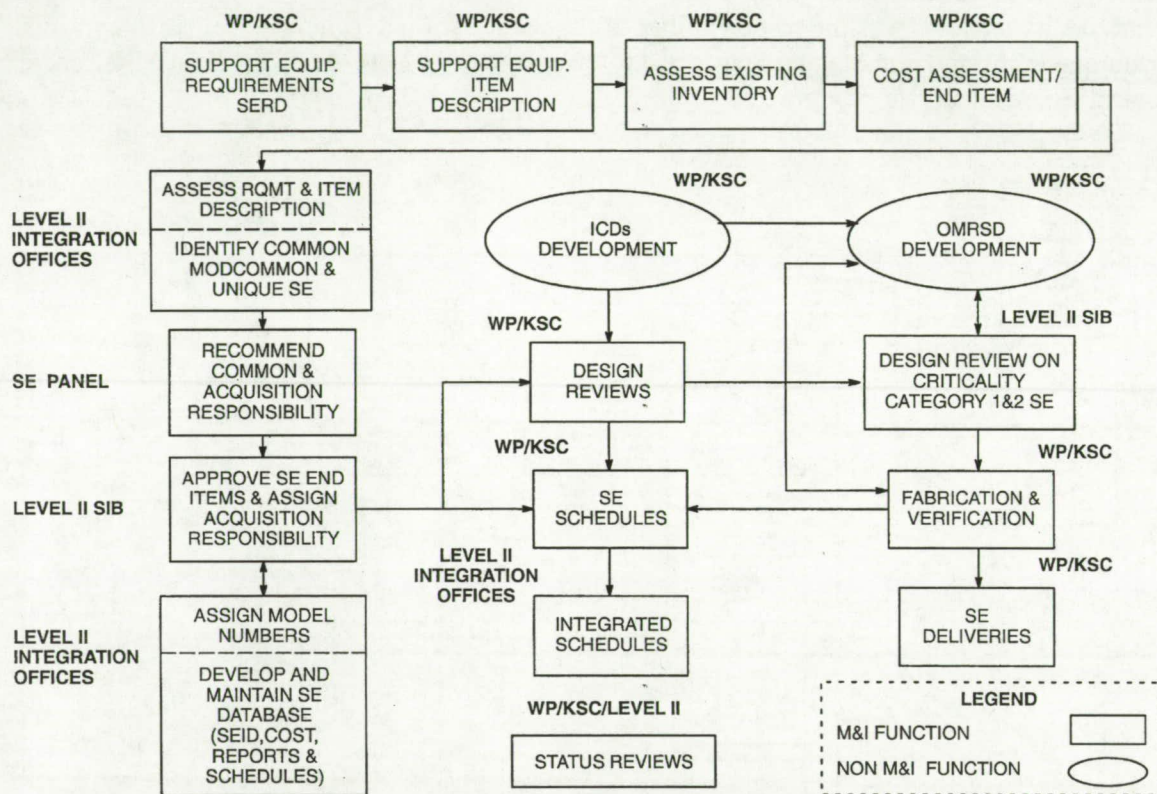

Figure 58: Support Equipment System Engineering Flow [NASA]

In the 1989, following several architectural design changes and diminishing support in Congress, changes were made to the Space Station Program management structure. A new program manager was assigned to lead the effort to address mounting cost and technical challenges. The new program manager de-emphasized commonality. One of the most significant changes to affect to the development of ground systems was the disbandment of Level II GSE Management Office at KSC. Responsibility for the development of GSE was pushed to the Level III Work Packages with little program-level involvement or coordination. Efforts to achieve some degree of commonality were now entirely the responsibility of the Level III projects. While the commonality plans remained 'on-the books', personnel involved with the Program recalled an immediate lack of management support at the Program level and noted distinct differences in the level of support for commonality between the four work package projects.

Problems with the Program continued in for the next three years and by 1993, Space Station Freedom was effectively cancelled. As part of larger effort to mitigate concerns over the proliferation of nuclear weapons technology following the collapse of the Soviet Union, President Clinton directed NASA to expand international partnership agreements to include Russia. The new Program was called International Space Station. A new space station design was developed that included Russian Service, Control, Docking and Multipurpose Research Modules. Russians also agreed to provide crew and cargo transport via Soyuz and Progress spacecraft.

The Freedom Program office in Reston, Virginia was closed and Program management was moved back to JSC. The overall Freedom management and contract structure (Figure 55) was determined to be too complex and lacking in accountability. NASA decided to centralize all development work for US elements under a single prime contractor (Boeing). It was hoped that a single prime contractor would reduce integration problems and help control costs. It was during this period that the new program management embraced a philosophy known as 'ship and shoot'. Spacecraft arrive at the launch site in a flight ready configuration. Only basic shipping and receiving inspections and minimal servicing are performed prior to installation into Orbiter's payload bay. In order to reduce the costs, planned pre-launch testing at the KSC was essentially eliminated. No integration tests between the elements were planned at the launch site. From a ground systems perspective, this resulted in a dramatic de-scope of the amount of GSE expected to be required at the launch site.

While the prime contractor was expected to perform some level of commonality analysis, those involved with the development of ground systems at the time felt a further de-emphasis of commonality. The original Freedom requirements documents and program plans including the commonality plans and the GSE integrations process developed for Freedom were abandoned at this time and new program level documents and were developed for ISS. No commonality processes were found within the new program documentation. Program management believed the reduction in planned pre-launch test and check-out would significantly limit the amount of GSE and little to no factory test equipment would be required at the launch site. KSC design standards include requirements for LOX compatibility, hazard proofing, corrosion protective coatings, high structural safety margins, safety assessments, etc. It was argued that KSC design standards unnecessarily increased costs of the development of factory test equipment. Therefore, the KSC design standards were not imposed on factory test equipment and the contractors were free to use their own standards in the manufacturing environment.

By the mid-1990s, the development of both Russian US flight hardware elements began to fall behind schedule. The planned first launch of the first ISS element slipped from 1997 to 1998. Driven by increases in complexity of on-orbit assembly, the number of EVA hours required to assemble the station grew from approximately 800 hours to over 1100 hours⁶⁹. NASA addressed these concerns by planning a series of Multi-Element Integration Tests at KSC (Chapter 2) and by directing the contractor to ship several partially built elements to KSC in order to speed final manufacturing and assembly.

The addition of MEITs and onsite manufacturing and assembly increased the amount of factory test equipment planned for use at KSC substantially. This presented a variety of challenges.

Several problems were already reported with the factory test equipment including leaks with ammonia servicing equipment and damage to Truss Elements by ground power supplies. The KSC design standards for Ground Systems contain the cumulative knowledge of years of experience developing facilities and systems to support operations at the launch site. Many of the requirements contained in the design standards are included to ensure the safety of workers and flight hardware. It was noted that problems with the ammonia servicing equipment at the factory likely would not have occurred if KSC design standards were followed by the Element contractor. The original Factory Test Equipment was discarded and a special unplanned vapor containment facility and additional ground systems were eventually constructed adjacent to the SSPF to support ammonia servicing operations. Problems were also reported with ground power supplies, load banks and simulators.

Personnel familiar with the problems with Element factory test equipment were reluctant to allow the factory test equipment to be used at KSC without thorough engineering evaluations and safety assessments. To address these concerns, a risk-based process was established to regulate the use of factory test equipment at KSC. Some equipment was approved for one time use while other equipment was determined to require complete Failure Mode & Effects Analysis including the identification of Critical Items. In 2001, Space Station Program Manager created a new Level 2 Support Equipment Control Board at KSC to provide a program level forum to address recurring issues with support equipment⁷⁰.

Despite the long and varied history of the management and development of ground systems supporting ISS, there are several examples of commonality between Level 3 projects and in one case, between programs. In the early 1990s, KSC did conduct commonality assessments prior to the start of any new support equipment designs. The assessment had to demonstrate that Spacelab, Shuttle and other programs were researched and no equal or similar equipment existed to perform the ground operations task. Lists for each Work Package were refined to limit duplication and to assign responsibility for the development of each piece of GSE. In most cases, support equipment required for a particular element was developed by the element contractor. KSC developed and provided most common equipment that was used to process multiple ISS elements. Examples of mechanical systems include the Cargo Element Lifting Assembly (CELA), Cargo Element Work Stands (CEWS) and Removable Overhead Access Platform (ROAP). The CEWS was re-used from the Spacelab Program. Agreements to apply commonality principles for these systems were established prior to the transition from Freedom to ISS.

Note: The Spacelab Program was conceived in the early 1970s as a means to extend the capability to perform science onboard the Space Shuttle, NASA conducted 25 missions with Spacelab components in the 1980s and 1990s. Spacelab components were designed and built by the European Space Agency. [NASA]

Examples of common command, control and communication systems include:

- Test Control and Monitoring System: TCMS is used to verify the compatibility of Space Station interfaces at KSC prior to launch primarily in support of utilization and re-supply and return operations.
- Communication and Tracking Check-out System: The C&TCS primarily verifies the functional interface compatibility of International Space Station (ISS) experiments and racks with the flight Communications and Tracking System (C&TS).
- Command and Data Handling System: The C&DH System primarily verifies the functional interface compatibility of ISS experiments and racks with the flight Command and Data Handling System (C&DH).

MSFC developed the Element Rotation Stands (ERS) to support several ISS elements including the MPLM's, Nodes, and US Laboratory Module. ISS Node 1 with a Pressurized Mating Adapter is shown below in an Element Rotation Stand.

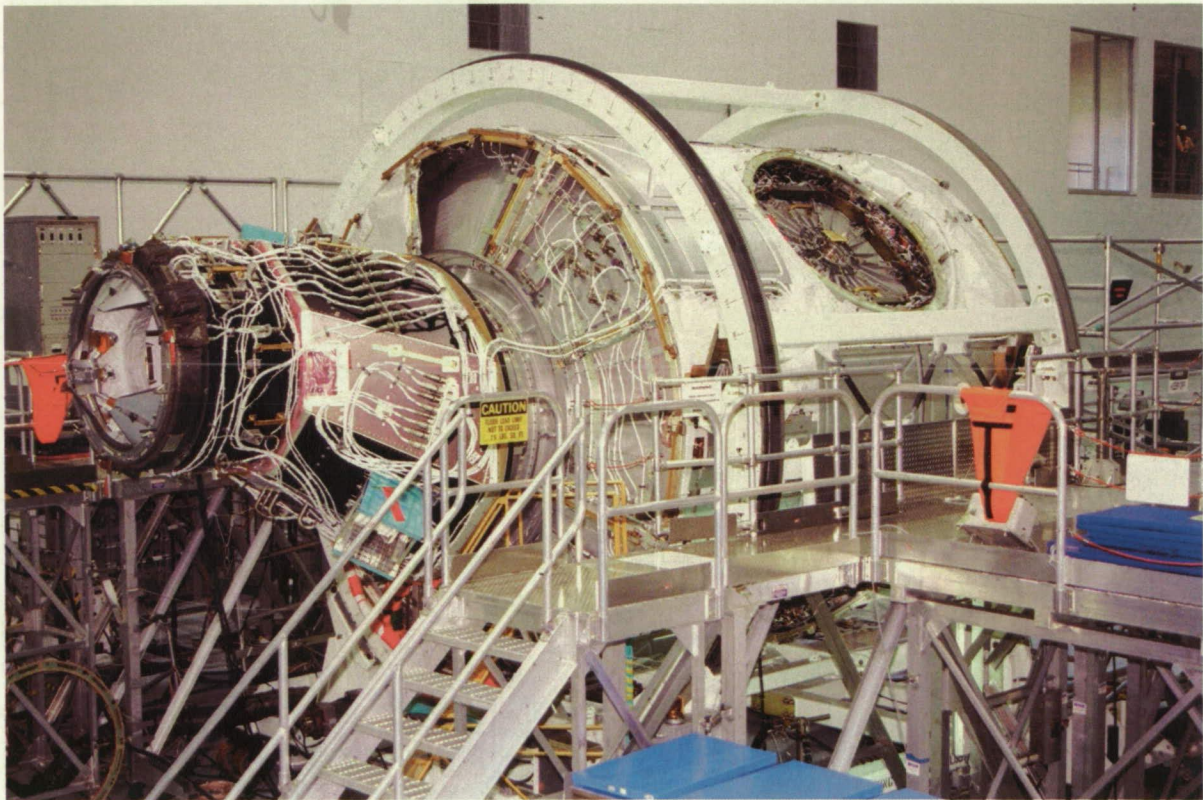

Figure 59: Node 1 in Element Rotation Stand in the SSPF [NASA]

Commonality with avionics subsystems on board flight elements enabled commonality with ground test equipment and operating procedures. The Multiplexer/De-multiplexers (MDMs) all used the same processor with different complement of I/O cards. This allowed standardized procedures for software loads and test execution for use during stand-alone element testing and MEITs.

Many subsystems and most experiments contained within the pressurized interior of Space Station Elements are mounted in racks based on a common design. Some of the racks were pre-installed at the factory while many others were installed at KSC as part of element processing. New experiment racks or racks containing Orbit Replaceable Units are carried to and from the Space Station via MPLMs. One example where commonality was not achieved was with Rack Insertion Devices used at the factory and KSC. The Rack Insertion Device (RID) used at KSC was designed for long term use and supported loads of over 2000 pounds. Alternate Rack Insertion Devices were developed for use at the factory for the US Lab Module, European Columbus Lab Module and the Japanese Experiment Module. The RIDs developed for use in the factory were smaller and much lighter than KSC design. Attempts were made to utilize a single design. However, it was determined that functional requirements between the various elements were not compatible and multiple RIDs were built. The KSC designed RID is shown below in Figure 60.

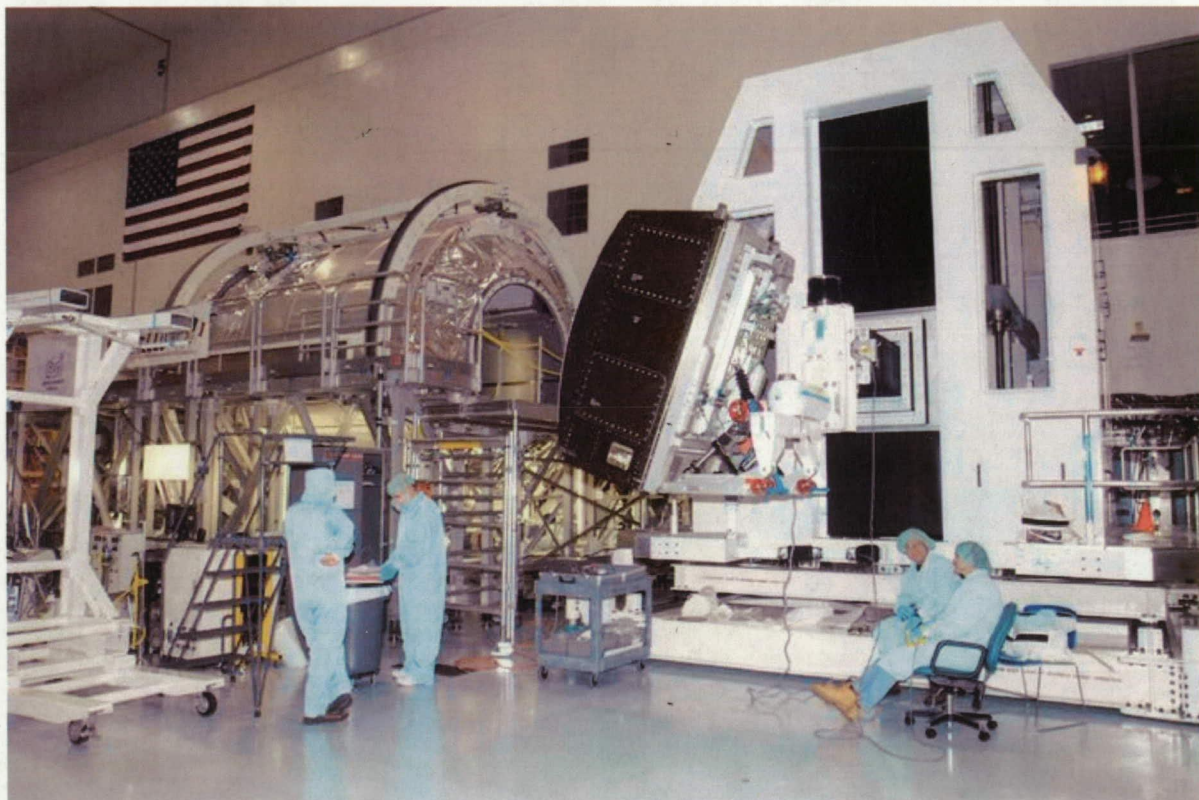

Figure 60: Preparing to install Racks with the KSC RID [NASA]

The early processes established during the Freedom phase of the Space Station Program presented opportunities to achieve commonality on a program-wide basis. As the Program evolved in the early 1990s, lack of program manager support limited the ability to achieve greater degrees of commonality of ground systems with tangible consequences following decisions to complete final manufacturing and assembly at KSC and to perform MEITs. However, commonality was

achieved in many cases with both mechanical and data systems. The following table summarizes commonality findings for ground systems developed for the Space Station Program.

Table 6: ISS Ground Systems Commonality Summary

ISS Ground Systems Commonality Summary		
Management and Planning		
Program Wide Policy	Yes*	The Program Commonality Plan clearly documented processes required to be followed by all program elements. *However, divergence was observed in the early 1990s following the change in program managers. Following the transition to ISS, policies established during the Freedom program were not continued at the program level.
Project Wide Policy	Yes*	*Since a program wide policy was in effect, project level commonality was by default required. However, no level 3 project policy documents were located. Personnel designing ground systems had to prove that no other systems existed either within the program and external to the program. Even after the transition from Freedom to ISS, attempts at achieving certain levels of commonality continued and were successful to some degree.
Timing	Program Formulation	Commonality Plans were established during concept developing in the mid-1980s. As stated above, divergence did occur during the transition from Freedom to ISS.
Contracts	Yes*	Early Work Package Contracts were required to follow the Commonality Plan. However, following the transition from Freedom to ISS, willingness to apply commonality between elements and KSC diminished with certain contractors.
Organization	Promoted	Organizational structure of the ground systems development organization at KSC did not negatively impact the application of commonality.
Levels of Commonality		
Between Programs	Yes	Cargo Element Work Stands were re-used from the Spacelab Program and the O&C high bay was used to support final manufacturing and assembly of several Truss Elements.
Between Projects	Yes	Several examples of commonality between projects (Station Elements) were observed at KSC with both mechanical and data systems.
Between Elements within Ground Operations Project	Not Applicable	Ground systems supporting Space Station processing were considered essentially one 'element'.
Between Subsystems within Ground System Elements	Indeterminate	It is likely this level of commonality did exist. However, analysis of specific designs was not performed to determine this for Space Station ground systems.
Types of Commonality		
Operations	Yes	Examples include avionics software load and check-out procedures and mechanical operations such as Element lifts and rotations.
Technology	Yes	Avionics ground test equipment in some cases consisted of same processor and I/O boards used on flight hardware.
Design	Indeterminate	It is likely this type of commonality did exist. However, analysis of specific designs was not performed to determine this for Space Station ground systems.

5.4 Constellation Program

Full scale development of both flight and ground systems to support the Initial Phase of the Constellation Program is underway. The 'Initial Phase' of the Constellation Program consists of development of the Orion Crew Exploration Vehicle, Ares I Crew Launch Vehicle and Ground Systems to support crew transport to and from the International Space Station. The 'Lunar Phase' of the program will consist if the development of the Ares V Cargo Launch Vehicle, Altair Lunar Lander and Lunar Surface Systems to support human missions to the lunar surface no later than 2020. NASA and contractor teams at all ten NASA centers are supporting the effort to develop the Ares I Crew Launch Vehicle, Orion Crew Exploration Vehicle as well as ground systems at the Kennedy Space Center as shown below in Figure 61:

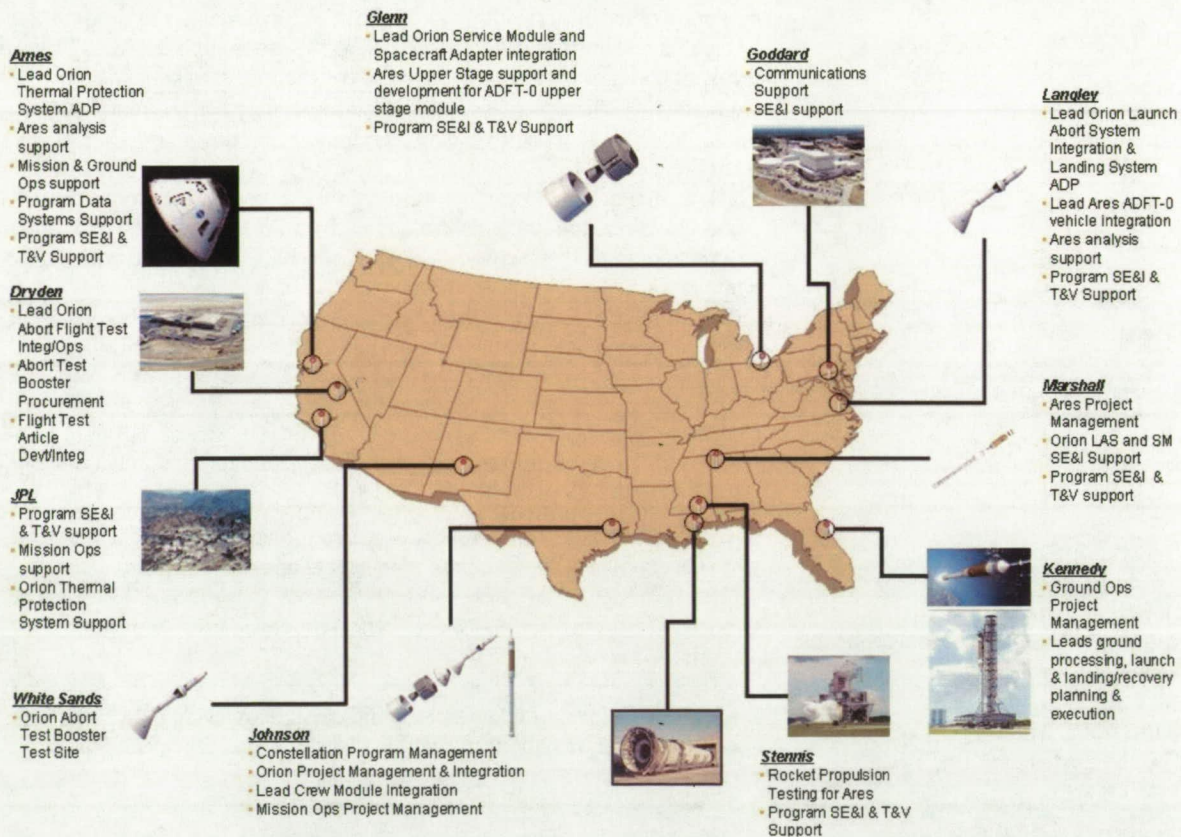

Figure 61: Constellation Work Distribution [NASA]

Constellation Program Management is based at the Johnson Space Center in Houston Texas and is commonly referred to as 'Level 2'. Orion, Ares, Mission Operations and Ground Operations Projects are referred to as 'Level 3' and are described below in Table 7.

Table 7: Constellation Level 3 Project Summary

Constellation Program		
Project Name	Lead Center	Primary Responsibilities
Orion Project	JSC	Development of the Crew Exploration Vehicle (CEV) System
Ares Projects	MSFC	Development of Crew Launch Vehicle (Ares I) and Cargo Launch Vehicle (Ares V) Systems
Ground Operations Project	KSC	Development of operations concepts and Ground System to support spacecraft and launch vehicle processing at KSC; infusing operability into the design of the spacecraft and launch vehicle systems during design; and planning for ground operations.
Mission Operations Project	JSC	Overall mission planning and execution. Oversees the transition of existing mission operations, planning and training systems such as control centers currently supporting Shuttle and ISS to support Constellation.
EVA Systems Project	JSC	Development of all space suit related hardware systems in support of Launch, Entry, Abort and Extravehicular Activities (EVA)
Altair Project	JSC	Development of the Lunar Lander System including both crewed and cargo variants
Lunar Surface Systems Project	JSC	Development of flight hardware systems to support the buildup of a lunar outpost and exploration of the lunar surface. Hardware elements under consideration include crew habitat; pressurized logistics modules; surface mobility systems; insitu resource utilization systems and surface power systems.

In addition to the NASA centers shown in Figure 61, contracts were awarded to several well known aerospace companies:

- Lockheed Martin: Orion Crew Exploration Vehicle
- Boeing: Ares I Upper Stage and Ares I Instrument Unit
- ATK: Ares I First Stage

Development for ground systems at KSC are led by NASA design teams augmented with support contractors. In most cases, modification and fabrication of new hardware are competitively awarded for discrete systems such as the Mobile Launcher and Pad Lightning Protection System. Single or multiple contracts will also be awarded to support the ground processing and launch operations in 2010 or 2011.

As indicated by Figure 61, Table 7 and the number of major contactors awarded, integration within the Constellation Program will be a complex task. The NASA Constellation Level 2 systems engineering team developed a number of programmatic documents to ensure technical integration across the Level 3 projects. The Constellation Commonality Plan was released in early 2008. Several types of commonality were defined including Identical; Interchangeable; Modular; Interoperable and Interchangeable. Several levels of commonality were identified as well including Commonality within systems and elements; Commonality between systems and

elements; Commonality within subsystems, assemblies and subassemblies; Commonality between subsystems, assemblies and subassemblies; Use of standard parts (EEE) and Commonality relative to the Software Support Environment (SSE).

The primary goals described in the plan are to lower mass by reducing the number of different spares and to potentially increase reliability. The commonality plan defines roles and responsibilities between Level 2 and Level 3 and includes provisions for periodic monitoring at Level 2 systems engineering control boards and at key program milestones including PDR and CDR. Data bases will be maintained to allow designers to search for existing parts/systems using the Commonality Assessment Tool (CAST). The Constellation Program also maintains a list of standard Electrical, Electronic, and Electromechanical parts to be used by the flight hardware projects. It also should be noted that the Constellation Architecture Requirements Document references commonality in several areas.

The Commonality Plan was developed to address commonality within flight hardware systems and specifically excludes ground systems and facilities. Therefore, commonality within ground systems is encouraged though not specifically required or monitored by Level 2. However, the Ground Operations Project, Orion and Ares are all collaborating closely to avoid development of duplicate ground systems. Working groups were established between the Ground Operations Project and flight hardware projects to identify and establish accountability for all GSE and SE expected to be used at KSC. Categories of this equipment include transportation and handling equipment, access kits, covers, commodity servicing equipment, electronic GSE, landing and recovering GSE, etc. Several thousand items are expected to be identified.

As discussed earlier in this chapter, problems with the development of GSE in Apollo and other spaceflight programs led to the development of GSE design standards. The problems were recognized by multiple NASA centers and some centers including KSC, developed their own standards (DE-512). As part of an effort to reduce conflicting standards, the Office of the Chief Engineer at NASA headquarters issued an agency wide GSE Standard in the mid-1990s: NASA-STD-5005 Standard for the Design and Fabrication of Ground Support Equipment⁷¹. Rev C of the document is under review and will be released this year. Thus, an important enabler for commonality between projects for ground systems is in place for the Constellation Program.

In 2006, KSC reorganized and created a center wide engineering organization. As shown in Figure 62, the structure of the new organization was based on discipline.

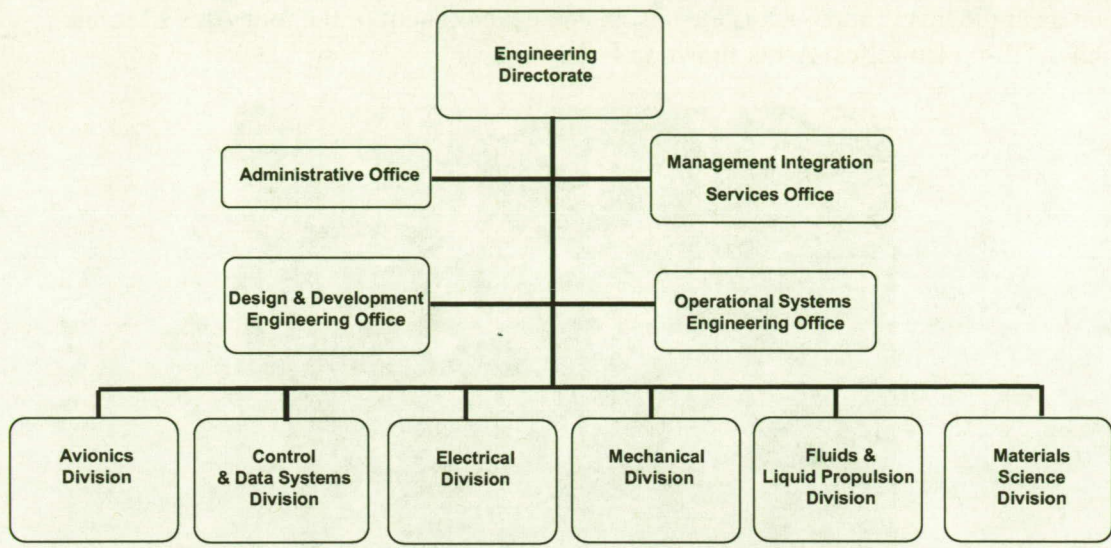

Figure 62: KSC Engineering Directorate [NASA]

As discussed in chapter two, Constellation ground systems at KSC are composed of Level 4 Elements and Level 5 subsystems. Subsystems frequently span multiple elements. In order to ensure design consistency for subsystem across elements, engineering personnel with the same discipline develop level 5 subsystems. Design reviews are conducted vertically for each element at level 4 and horizontally for each subsystem at level 5.

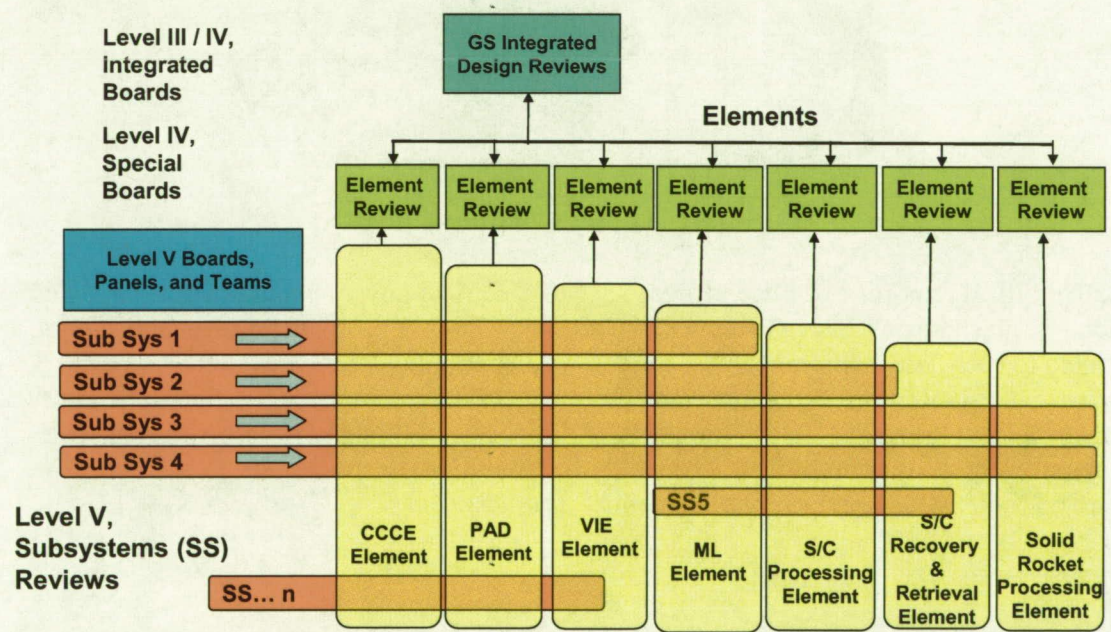

Figure 63: Level V Subsystem Integration across Ground System Elements [NASA]

A good example this is approach is the design and development of the four Ares I Mobile Launcher Tilt-up Umbilical Arms shown in Figure 64.

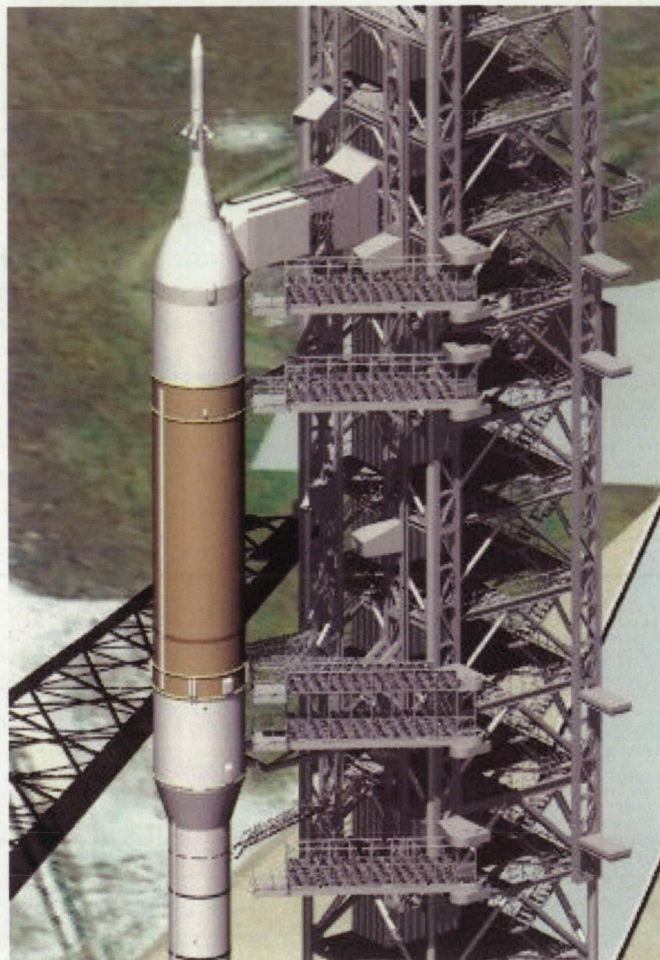

Figure 64: Tilt-up Umbilicals [NASA]

Each Umbilical requires expertise in areas such as electrical power, pneumatics, cryogenics, structures, mechanisms and environmental control systems. Engineers from each discipline are matrixed to each Tilt-up umbilical design team while retaining strong ties to the home engineering organization. A Lead Design Engineer (LDE) is assigned to each umbilical to oversee the development of each Umbilical. A ‘Super Lead Design Engineer’ oversees the development of all four umbilicals. The umbilical design team structure is shown below in Figure 65 (note: not all engineering disciplines are shown).

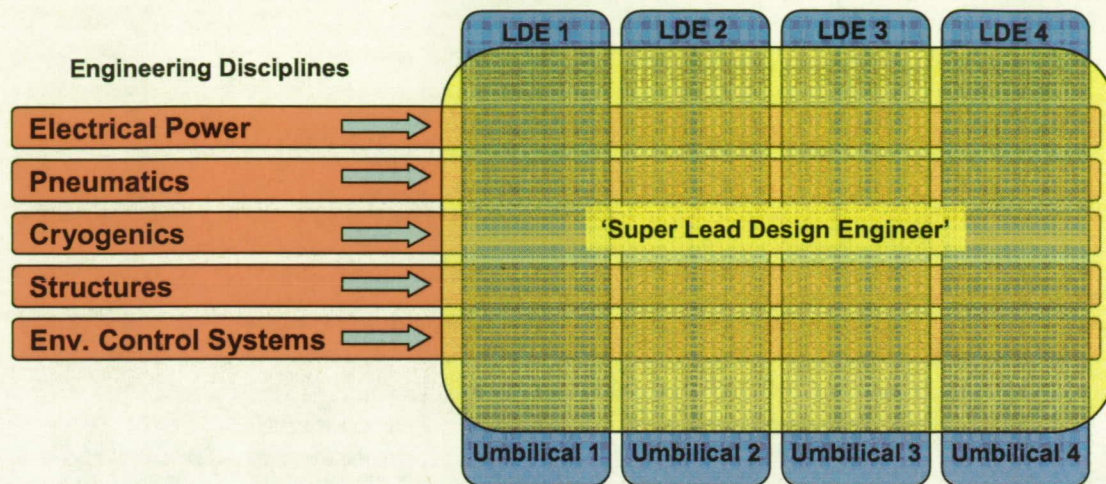

Figure 65: Tilt-Up Umbilical Design Team Structure

The Super LDE is responsible for ensuring commonality in design and in component selection across all four umbilicals. While there is no specific commonality plan in place for the Ground Operations project, the extensive experience base present in both design and operation organizations at KSC recognize the value common design and parts. The use of standard parts, common designs and compliance with well known standards is accepted as standard practice at KSC.

Tests in support of development of the Ares I Upper Stage propulsion system will be performed with a Main Propulsion Test Article (MPT) in modified test stands at the MSFC beginning sometime in Fiscal Year (FY) 2011. The manufacturing and assembly of the Upper Stage will occur at NASA's Michoud Assembly Facility in Mississippi. Prior to transportation to KSC, Upper Stage acceptance tests will be performed at SSC. The Acceptance Tests, also referred to as 'Green Runs', are planned for each Upper Stage for the first several test flights and operational missions. As part of Ares I Upper Stage test planning, the Common Propellant Distribution System (CPDS) development team was formed to explore the potential for commonality between ground systems at KSC, MSFC and SSC. Anticipated commonality benefits were reduced life cycle costs and early operation test experience for systems planned for use at KSC - 'Test as fly, Fly as you test'.

The team consisted of representatives from MSFC, KSC, SSC and GRC. Sub-teams were formed from engineering disciplines including mechanical and fluids; command and control; and purge, vent and drain; and GSE. Systems engineering and project support sub teams included safety and mission assurance; requirements; risk management, configuration management and CAD modeling.

The CPDS team formed in spring 2007 and immediately began developing a candidate list of GSE for use at all three test sites:

- LH2 Tank Relief/Vent Valve Actuation Panel
- LH2 Fill & Drain Skid with associated pneumatic support panels

- LH2 Vehicle Fill & Drain Valve Actuation Panel
- LH2 Pre-Press Panel (Helium supply only)
- LO2 Tank Relief/Vent Valve Actuation Panel
- LO2 Fill & Drain Skid with associated pneumatic support panels
- LO2 Vehicle Fill & Drain Valve Actuation Panel
- LO2 Pre-Press Panel (Helium supply only)
- CGHe Bottle Fill Panel (Helium supply only)

The simplified drawing of the common GSE considered for CPDS is shown below in Figure 66.

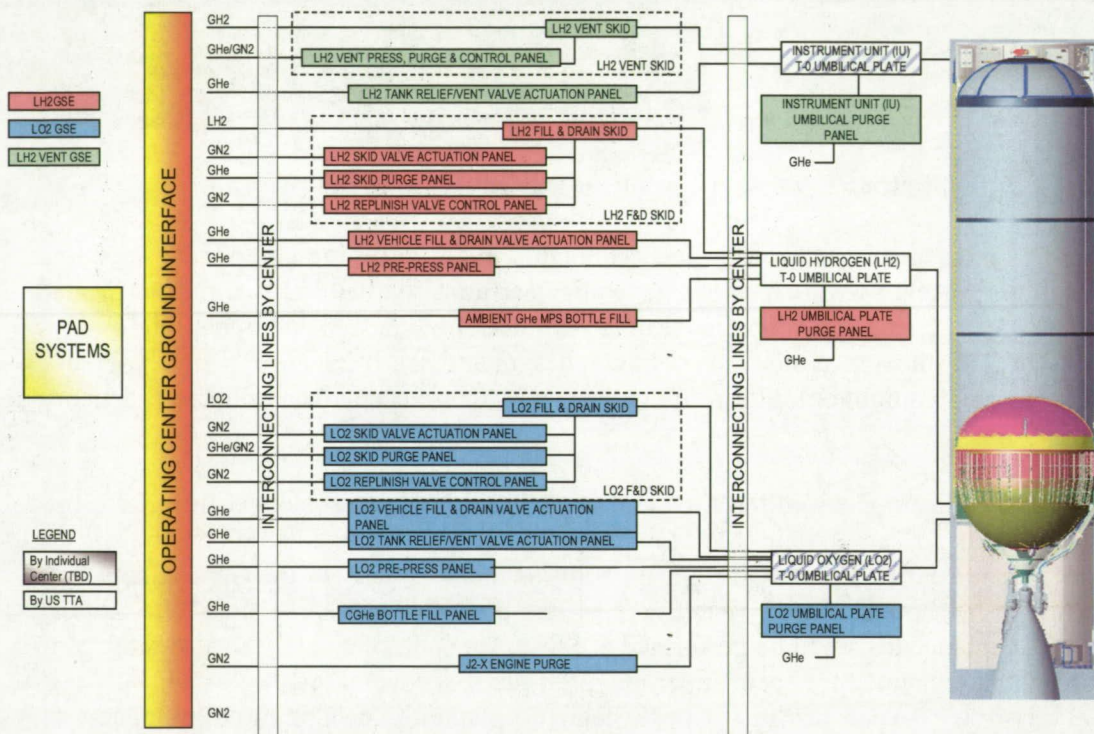

Figure 66: CPDS GSE [NASA]

Key ground rules and assumptions were established early including:

- Systems shall be designed to KSC specifications and standards per NASA-STD-5005 and the KSC launch pad environment.
- Fluid systems design will follow KSC launch operations design for all performance critical function systems.

Detailed planning and trade studies continued into late 2007. Budget estimates were produced for different levels of common GSE ranging from 50% to 100% for the three test sets. However, while KSC planned to procure entirely new GSE to support Upper Stage fueling operations during launch countdown, SSC planned to leverage off legacy systems during the development of initial project budgets in 2006 and 2007. Thus, in order to achieve some levels of

commonality, the program would have to provide additional funds to SSC and MSFC. Total costs for 100% commonality were estimated to be over \$15M. Constellation Program budgets for FY2008-FY2010 are constrained. Ultimately, the CPDS team had to settle on an approach that relied on GSE manufactured with available components at SSC and MSFC that did not require additional funds. The procurement of any new parts determined to be critical to test operations will be identical to those in use at KSC. Thus, a certain degree of component commonality will be achieved. However, many of the operation benefits rely on early test of an integrated system common to KSC. Therefore, the operational benefits to KSC likely are significantly reduced.

The use of common control and data acquisition systems for Upper Stage test and operations at all three centers was also briefly investigated. As with the propellant GSE, existing legacy systems were already planned for use at MSFC and SSC while KSC planned to develop new systems. Operators at SSC preferred to maintain commonality between SSC's own test stands using the legacy systems. They expressed concerns over costs and the technical risk of replacing existing control systems in other test stands to maintain commonality within SSC. It was also noted that KSC's redundancy requirements would likely reduce response times at SSC violating high speed response time and data recording requirements. MSFC also objected to the commonality proposal for similar reasons. The project need dates for various levels of capabilities within each project were not in alignment further complicating commonality between the three centers.

The Constellation Program is currently investigating the application of commonality across projects in command, control and communication systems. Preliminary studies were conducted in 2006 to determine the feasibility of using the same or similar systems in control centers at JSC and KSC. A trade tree was constructed as shown in Figure 67 to assess various control center architectures as well as commonality.

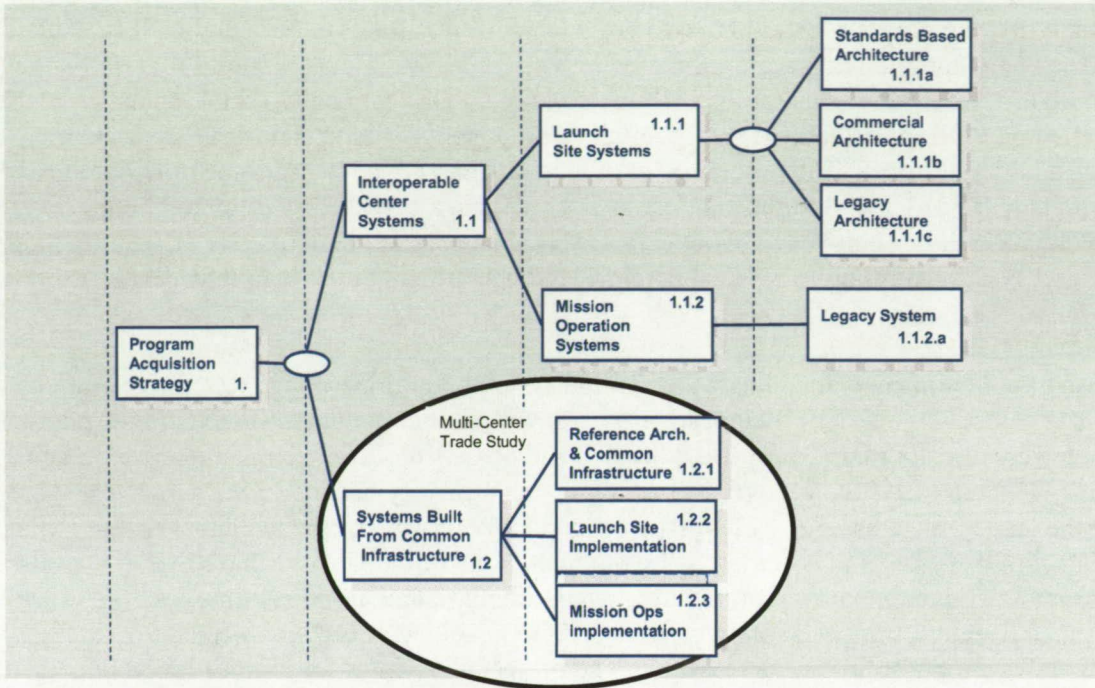

Figure 67: Launch Control System - Mission Control System Trade Tree [NASA]

Various levels of commonality were assessed for risk and benefit as shown in Figure 68.

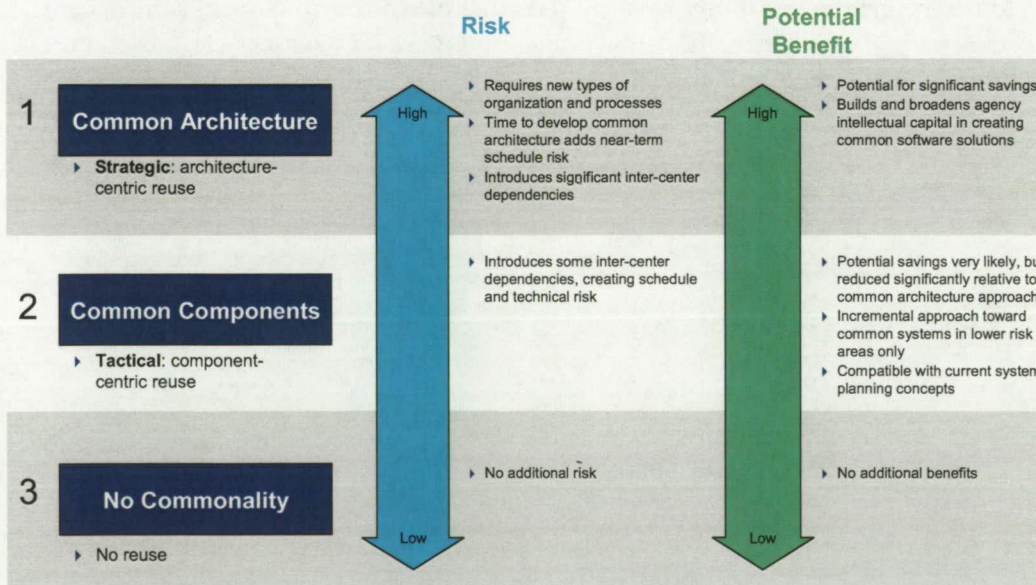

Figure 68: Early Control Center Commonality Risk Benefit Summary [NASA]

The study found that increasing the level of commonality increases risk in terms organizational dependencies. These and other early studies resulted in the formation of the Command, Control

and Communication Team (C3I) that now includes members from most NASA centers. The C3I vision statement is as follows:

“To ensure that Constellation Systems can be controlled safely, reliably, affordably, and robustly while planning for evolvability, interoperability, commonality, and sustainability by using standards, architectural constructs (layers, components, etc.) and an end-to-end engineering approach.”

Significant progress was made during the last year on developing C3I specifications to enable interoperability across the Constellation Program. C3I specifications apply to communications between Level 3 projects. Intra-communication within Level 3 projects is not required to follow C3I specifications.

While commonality is a goal for Constellation Command, Control and Communication Systems, it is not a requirement. However, commonality studies between Orion factory control systems and KSC Launch Control Systems are underway. The number and complexity of subsystems required to be monitored by the Launch Control System is dominated by the Ares I Upper Stage as shown in Figure 69.

MLE Subsystems Monitored and Controlled By LCS																					
	Orion	Ares	LO2	LH2	HYD	HYPER	ECS	CGHE	Bair	GHE	GN2	GO2	VAA	CAA	SDS	HGLDS	TCS	RSCS	LRS	GSP	
LO2		x																			
LH2		x								x	x					x					
HYD		x								x	x										
HYPER	x	x									x										
ECS	x	x								x	x					x					
CGHE		x		x							x										
Bair	x									x	x										x
GHE	x	x	x	x		x															
GN2		x	x	x		x				x											
GO2	x																				x
VAA		x																			x
CAA	x						x		x	x											x
SDS		x																		x	x
HGLDS																					x
FS TCS		x																			x
RSCS		x																			x
LRS		x													x						x
GSP	x	x	x	x	x	x					x					x		x	x		

Figure 69: Launch Control System Subsystem Control and Monitoring [NASA]

The number of systems to be monitored by the Orion Factory Control System is far less than the combined Ares, Orion and Ground Systems that will be monitored by the Ground Operations Launch Control System (Chapter 2). Furthermore, the level of required redundancy and other safety considerations for critical launch operations is greater than requirements in the factory environment. Thus, there are considerable differences between the operating environments for the two systems further complicating the commonality trade study.

As stated in Chapter 2, the Shuttle Launch Complex 39 will be modified to support Ares I and Ares V launch operations. However, in 2006 a study was conducted to assess the feasibility and benefits of using Launch Complex 40 (Titan) for Ares I/Orion. Operations concepts and high level ground system architecture were developed to perform a technical risk and cost assessment. While using Complex 40 was determined to be technically feasible, the study indicated that near

term DDTE costs far exceeded DDTE costs for Complex 39 as shown in Figure 70. Relative costs are shown on the vertical axis. The vertical axis starts at 0.

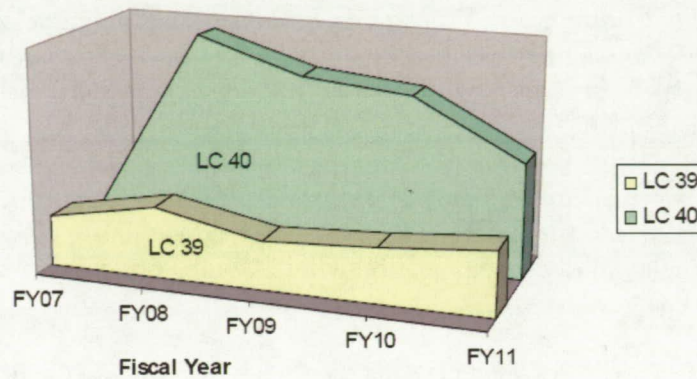

Figure 70: LC-39/LC-40 DDTE Cost Comparison [NASA]

Figure 70 illustrates the magnitude of funding required for substantial modifications to an existing Pad not originally designed for vehicles the size of Ares I. Primary cost drivers were the need to replace virtually every LC-40 ground system, modify the flame bucket, build a new vertical integration facility, build new transporters, etc. The cost to develop a new Pad would be much greater. In this case, cost was the dominant factor enabling commonality between Shuttle Program and Constellation and for ground systems supporting Ares I and Ares V.

As shown by the LC-39/LC-40 study, substantial cost savings are being realized early in program through the high level of reuse between the Shuttle and Constellation Programs. Commonality between the Shuttle and Constellation programs is being achieved primarily with facilities, structures, large mechanical systems and large fluid systems. The Shuttle Launch Processing Systems will be replaced with the new Launch Control Systems. However, modern programmable logic designs in use to monitor and control systems at the Pads today will be re-used in Constellation. Reuse between Shuttle and Constellation Program is shown in Table 8.

Table 8: Shuttle to Constellation Ground Systems Re-use

Shuttle to Constellation Ground Systems Re-use	
Ground System	Comments
Industrial Area Institutional Support Facilities and Infrastructure	Headquarters Building, Central Instrumentation Facility, Occupational Health Facility, Training Auditorium, warehouses and numerous other smaller facilities were all reused. Supporting infrastructure such as roads, railways, sea ports, power distribution systems, water systems, etc were also reused.
Operations and Check-out Building Astronaut Crew Quarters and High Bay	O&C High Bay is in the process of being completely gutted and refurbished to support Orion final manufacturing and assembly. Astronaut Crew Quarters will be used for Constellation.
Hypergolic Maintenance Facility	Will not be required for Constellation
Vehicle Assembly Building	High Bays 1-3 will support Ares I/Orion and Ares V/Altair vehicle stacking and integration.
Mobile Launch Platforms (MLP)	One MLP will be used to support the Ares I-X Test Flight in April 2009 (one time use only). A new Mobile Launcher will be constructed for Ares I (Shuttle manifest would not support early turnover of a Shuttle MLP for re-use). One Shuttle Mobile Launch Platform will be used for Ares V.
Crawler-Transporter	At least one Crawler Transporter will be reused. A new Crawler Transporter may be required for depending on Ares V configuration (roll-out weight).
Crawler Way	Tests are underway to determine whether or not upgrades are required.
Launch Control Center (LCC)	All LPS equipment will be removed from the firing rooms. LCC Firing Room one was decommissioned in 2007 and LCS equipment is being installed to support Ares I-X. Only two of four Firing Rooms are planned to be used for Constellation.
Launch Pads 39A and 39B	Pad B will be used to support Ares I/Orion Launch Operations and Pad B will be used to support Ares V/Altair Launch Operations.
Orbiter Processing Facilities	Will not be required for Constellation
Assembly and Refurbishment Facility	Will be used to support SRB refurbishment for Ares I and Ares V
Rotation, Processing and Surge Facility	Will be used to support SRB stand-alone operations for Ares I and Ares V

The Commonality summary for the Constellation Program is shown in Table 9 on the following page.

Table 9: Constellation Ground Systems Commonality Summary

Constellation Ground Systems Commonality Summary		
Management and Planning		
Program Wide Policy	No	CxP 70132 was developed address commonality within flight hardware systems and specifically excludes ground systems and facilities. Therefore, the Commonality within ground systems is encouraged though not specifically required or monitored by Level 2. However, the Ground Operations Project, Orion and Ares are all collaborating closely to ensure duplicate ground systems are not developed and that ground systems developed by flight hardware provides for use at KSC are designed in accordance with Agency level GSE design standards.
Project Wide Policy	No	No commonality plans exists for the ground operations project. However, program and project management strongly encourages projects to seek common design solutions for both flight and ground systems as evident by the studies directed to examine commonality. During design of Level 5 subsystems, lead design engineers verify commonality of design and components.
Timing	Project Design	CxP 70132 was after SRR for Ares, Orion and Ground Operations.
Contracts	Yes*	Flight Hardware contractors are required to develop ground systems to STD-5005B. However, contracts were awarded prior to the release of the Commonality Plan.
Organization	Promotes	Structure of the ground systems design organization at KSC promotes commonality of design and component selections for Level 5 subsystems.
Levels of Commonality		
Between Programs	Yes	Significant re-use between Shuttle and Constellation Program as described in Table 8.
Between Projects	Yes	Ground Operations Project, Orion and Ares are all collaborating closely to avoid development of duplicate ground systems. Working groups were established between the Ground Operations Project and flight hardware projects to identify and establish accountability for all GSE, FSE and SE expected to be used at KSC.
Between Elements within Ground Operations Project	Yes	Level V subsystems are designed 'end-to-end' across multiple elements. Therefore, commonality of design and components exists between elements.
Between Subsystems within Ground System Elements	Indeterminate	Subsystem designs are not sufficiently complete to make this determination. However, this level of commonality is likely for subsystems within the Command and Control Element.
Types of Commonality		
Operations	Yes	Shuttle payload processing. Similar operational procedures are used to test and check-out payloads prior to installation in Orbiter payload bay.
Technology	Yes	Establishment of common components for Level 5 subsystems including electrical and fluid systems components for use in multiple ground systems.
Design	Yes	Tilt-up Umbilical Arms are good examples of design commonality.

5.5 Special Topic: Commonality within Facilities and Facility Systems

A complete discussion regarding commonality at the launch site includes facilities. The development and modification of facilities and facility systems equipment at KSC represents an important and substantial part of preparing the launch site for new programs. Minimizing life cycle costs for operating and maintaining facilities and facility systems is driven in part to the variability and reliability of facility systems equipment. Over the years, facility design engineers at KSC standardized on power meters, protective relays, programmable logic controllers, fire alarm control panels, lift stations and interfaces to Kennedy Complex Control Set (controls air conditioning, power, etc across the entire center). Project Managers have standard design checklists and templates for design projects to ensure standard parts and designs are used. This also ensures designers address all Federal, State, NASA and KSC regulations, policies, standards, best practices and lesson learned. All 60% and completed design packages for Constellation are reviewed by the managers and leads.

6 Summary and Forward Work

The application of commonality in ground systems used for launch operations emerged following multiple problems cited during development and operation GSE to support launch vehicle and spacecraft ground operations during the Apollo program. The ACE system was the best example of commonality applied across projects and between the operational and manufacturing environment. However, ground operations personnel at KSC were faced with GSE that did not work and was difficult to maintain and operate. Underlying causes for these problems were traced to a lack of design standards for equipment designed to accommodate the unique environment of KSC, organizational issues with GSE development teams and the lack of establishing a deliberate program policy early in the program to apply commonality with GSE developed by multiple flight hardware projects. To put it more simply, the NASA/contractor teams of the 1960s were young and relatively inexperienced. At the time, Apollo was the most complex development program both in terms of new technology requirements and the integration required to manage the large and varied NASA/contractor teams.

Beginning with the Space Task Group of 1969, the value of commonality was recognized at the earliest phases of the Space Shuttle Program as part of the goal to significantly reduce both development and operational costs of space flight. KSC Center Director Debus specifically applied the Space Task Group's call for commonality during the initial ground systems concept development. Leveraging off the lesson's learned from Apollo, KSC developed design standards for ground support equipment, support equipment, facilities and facilities systems. Development organizations were organized by engineering discipline and matrixed to project organizations developing ground systems. The new standards enabled commonality of systems required at both the factory and launch site without the need for costly redesigns. New organizational structures based on discipline ensured commonality of ground systems designs in use across the space center such as fluid and gas systems, command and control systems and mechanical systems. Commonality of systems used to fuel the Space Shuttle for launch operations and the main propulsion test stands at SSC were excellent examples of reducing overall GSE development costs between the two development centers. It also provided an opportunity to test GSE, complex software algorithms and operational procedures prior to the arrival of the flight hardware at KSC.

The Space Station Commonalty Program (SSCP) was the clearest and most comprehensive effort to achieve commonality of the four programs studied for this paper. The SSCP established accountability; authority; policy; processes; and tools for commonality that applied to both flight and ground systems across the program. A Level 2 Program GSE Management Office was established at KSC to over see the development of all GSE across the program. The SSCP was established during formulation prior to the detailed design and applied to the contractors building the flight hardware. All the 'ingredients' required for a successful commonalty effort were in place early in the program. Commonality agreements were made with the development of several mechanical systems including the Cargo Element Lifting Assembly, Cargo Element Work Stands and Removable Overhead Access Platform and were later used to support multiple elements. However, leadership changes in the Space Station Program in the late 1980s illustrate the effects of limited support for commonality by program management. Almost overnight,

commonality was de-emphasized. In fact, many of the lessons learned from the Apollo Program that were applied during the Shuttle Program were abandoned in an effort to control growing costs of the program. Driven by the 'ship and shoot' philosophy, expectations for the design and development of factory test equipment and GSE were marginalized by limited application of ground system design standards. The Level 2 GSE office at KSC was abolished and flight hardware contractors were given freedom to develop factory test equipment to their own standards. Commonality was essentially a voluntary activity to be managed by Level 3 Projects with little to no oversight by Level 2.

Following the transition from Freedom to ISS in 1993 and in an effort to overcome schedule delays with the manufacturing of flight hardware, several station elements were shipped to KSC with significant travelled work (incomplete factory assembly). Problems appeared immediately with factory test equipment and GSE including fluid servicing equipment, ground power supplies, load banks and simulators. Eventually, the Space Station Program Manager re-established Level 2 Support Equipment Control Board at KSC to provide a program level forum to address recurring issues with support equipment.

While the Constellation Program did establish a commonality plan at the program level, compliance for ground systems development is voluntary. However, program and project management strongly encourages projects to seek common design solutions for both flight and ground systems. Constellation program and project management clearly support requirements for ground system design standards and the C3I initiatives. They have directed studies to examine commonality in command and control systems and many other areas within Constellation. Tools provided at the program level are available to be used for ground systems commonality assessments. The extensive experience base present in both design and operation organizations at KSC recognize the value common designs and components. At KSC, commonality is facilitated by the structure of the design organizations responsible for the 'end to end' subsystem design at Level 5. The use of common parts, common designs and compliance with well known standards is accepted as standard practice at KSC and other NASA centers responsible for the development of ground systems. The cost of replacing center infrastructure and major ground systems such as the VAB, Launch Pads, Mobile Launch Platforms and LCC for Constellation would likely cost a billion dollars or more. As with the Apollo to Shuttle Transition, the applying commonality between to the Shuttle and Constellation Programs yielded substantial cost savings.

A summary of key factors for ground system commonality is shown below in Table 10.

Table 10: Key Factors for Ground System Commonality

Factor	Comments
1) Leadership	<ul style="list-style-type: none"> • Compliance with commonality initiatives is highly dependent on program manager support.
2) Timing	<ul style="list-style-type: none"> • Early deployment of policy and processes is critical to avoid arguments against commonality due to rework costs later in the design cycle and costly modifications to contracts awarded before commonality policy is established. • Opportunities for commonality should be identify during architecture development and continue through system decomposition with the goal to identify common systems and subsystems as early as possible • Understand relevant operations concepts early to develop requirements that support all operating environments planned for common systems/sub-systems. <ul style="list-style-type: none"> ○ Small differences in operating environments can lead to significant variability in architecture, requirements and implementation.
3) Standards	<ul style="list-style-type: none"> • Ensures compatibility with launch site environments
4) Organization	<ul style="list-style-type: none"> • Design Organization facilitates commonality across elements developed within a single implementation organization. • Strong Systems Engineering and Integration at Level 2 enables commonality approach to be optimized for overall program performance. • Once a common system or subsystem is identified, accountability should be assigned early to a single design organization to avoid the natural tendencies to propose and develop competing solutions. [This is not to imply a limitation on stake holder involvement for all applications.]
5) Policy, Processes and Tools	<ul style="list-style-type: none"> • Provides necessary rigor required to enforce, monitor and measure commonality effort • Tools provide a standard means assess commonality consistently across projects
6) Contracts	<ul style="list-style-type: none"> • Must include requirements to comply with commonality processes • Contractors should be incentivized to identify commonality opportunities and support program wide commonality initiatives
7) Flight Hardware Architecture	<ul style="list-style-type: none"> • Fewer flight hardware to ground systems interfaces drives ground system to flight hardware integration across the entire vehicle stack (integrating example of Space Shuttle Orbiter) • Proliferation of unique subsystems on the launch vehicle and spacecraft leads to proliferation of unique GSE on the ground.
8) Re-use of Legacy Systems	<ul style="list-style-type: none"> • The most dominate costs savings factor that can be attributed to commonality of ground systems. Type of Commonality is re-use. Level of Commonality is between programs (re-use of existing ground systems from prior programs such as Launch Complex 39, the Vehicle Assembly Building, Mobile Launch Platforms, Off-line check-out facilities, etc). • In some cases, legacy systems hinder commonality between projects in new programs (one project using a legacy system while another project using a new design).

The primary value of this paper is capturing historical perspectives and identification of key factors affecting commonality of ground systems in all four major human space flight programs at KSC. The breadth of this paper is wide and specific examples of both successful and unsuccessful applications of commonality are captured for each program. However, many questions remain and deeper penetration into existing ground systems may help to quantitatively understand the 'levels' of ground systems commonality actually achieved at KSC, other centers and in factory environments. For example, the Shuttle Program has over 5000 discrete types of GSE items at the KSC. It would be interesting to determine how many of these items already exhibit or could exhibit some degrees of commonality; what ground system domains (fluids, mechanical systems, command and control, power, etc.) are more likely to benefit from commonality; and what levels (element, system, subsystem, component).

A successful strategy for commonality is not without some degree of additional and largely near term development costs. Imposing commonality requirements will constrain designs and will most likely require far more upfront planning and coordination than traditional methods for system development. Additionally, constrained designs may be less likely to be optimized for their specific application within an element. This may actually increase costs in certain areas. Successful implementation will require both the leadership and development personnel to take a holistic view to fully assess the right approach as well as the right level of commonality. Consideration must be given both to potential benefits as well as costs prior to mandating commonality for large-scale engineering systems. The project manager is faced with the many questions:

- What are the benefits of commonality and how are the benefits measured?
- To what degree and confidence level can the benefits of commonality be depended up to achieve reductions in lifecycle cost during both development and operations?
- How much should commonality drive the design and development process?
- What are the costs of imposing commonality?
- What are the risks of imposing commonality?

Methods are needed to answer these questions to be able quantify and predict the benefits of commonality of ground systems. A key enabler of the successful application of commonality is establishing a formal policy during the formulation phase of the program. However, the program manager is faced with hundreds of complex policy decisions early in the program that in many cases, may limit productivity of the development team. Therefore, each policy decision must be made carefully to ensure it is truly value added, provides a positive return on investment and directly supports the over all goals of the program. The ability to predict benefits will lead to greater management support and lead to a successful commonality program.

References

- ¹ Huzel, Dieter K., *Peenemunde to Canaveral*, Prentice-Hall, Inc., Englewood Cliffs, N.J., p. 200.
- ² Dori, Dov. *Object-Process Methodology*. 2002
- ³ <http://www.thefreedictionary.com/weather>
- ⁴ Air Force Space Command Manual 91-710 Volume 1, July 2004.
- ⁵ Liparito, Kenneth; Butler, Orille R. *A History of the Kennedy Space Center*. University Press of Florida, 2007 pages 35-39.
- ⁶ http://www.nasa.gov/mission_pages/explorer/sputnik-20071002.html; First Contact: Sputnik (NASA History)
- ⁷ <http://history.nasa.gov/factsheet.htm>; A Brief History of NASA.
- ⁸ Liparito, Kenneth; Butler, Orille R. *A History of the Kennedy Space Center*. University Press of Florida, 2007 page 46.
- ⁹ "A National Space Vehicle Program: a Report to the President" January 1959, Often referred to as by the named for the principle author - Milton Rosen, a NASA Propulsion Engineer.
- ¹⁰ Liparito, Kenneth; Butler, Orille R. *A History of the Kennedy Space Center*. University Press of Florida, 2007 page 46.
- ¹¹ Benson, Charles D.; Faherty, William B. *Gateway to the Moon*. University Press of Florida, 2001 pages 17-20.
- ¹² http://en.wikipedia.org/wiki/Cape_Canaveral_Air_Force_Station_Launch_Complex_34.
- ¹³ Benson, Charles D.; Faherty, William B. *Gateway to the Moon*. University Press of Florida, 2001 page 11.
- ¹⁴ NASA. <http://www.hq.nasa.gov/office/pao/History/SP-4205/ch1-6.html> [Chariots for Apollo: A History of Manned Lunar Spacecraft.
- ¹⁵ John F. Kennedy Presidential Library and Museum
<http://www.jfklibrary.org/Historical+Resources/Archives/Reference+Desk/Speeches/JFK/003POF03NationalNeeds05251961.htm>
- ¹⁶ Erikson, Mark. *Into the Unknown Together The DOD, NASA, and Early Spaceflight*. Air University Press, Maxwell Air Force Base, Alabama, 2005 page 309 (By 1965, there were at least 88 'major agreements' between DOD and NASA).
- ¹⁷ Benson, Charles D.; Faherty, William B. *Gateway to the Moon*. University Press of Florida, 2001 page 87.
- ¹⁸ Robbins, W.H., Finger, H.B. *An Historical Perspective on the NERVA Nuclear Powered Rocket Engine. Technology Program*. Prepared for Lewis Research Center under contract NAS3-25266. 1991 page 2
- ¹⁹ Benson, Charles D.; Faherty, William B. *Gateway to the Moon*. University Press of Florida, 2001 page 68-73
- ²⁰ NASA. <http://history.nasa.gov/SP-350/i3-8a.jpg>.
- ²¹ Benson, Charles D.; Faherty, William B. *Gateway to the Moon*. University Press of Florida, 2001 page 87-94.
- ²² Ibid Page 97.
- ²³ Ibid. Page 99.
- ²⁴ Ibid. Page 3.
- ²⁵ <http://en.wikipedia.org/wiki/ALSEP>.
- ²⁶ Benson, Charles D.; Faherty, William B. *Gateway to the Moon*. University Press of Florida, 2001 page 73-85.
- ²⁷ KSC, Catalog of Launch Vehicle Tests, Saturn V, Apollo/Saturn V, Revision 1, 15 June 1966, GP-244
- ²⁸ Jenkins, Dennis R., Mars, Charles B., Capellin, Amador., *Apollo Lunar Module KSC Processing White Paper R13*. 2006.
- ²⁹ NASA. <http://science.ksc.nasa.gov/facilities/vab.html>
- ³⁰ NASA. <http://science.ksc.nasa.gov/facilities/crawler.html>
- ³¹ NASA. <http://science.ksc.nasa.gov/facilities/lc39a.html>
- ³² Liparito, Kenneth; Butler, Orille R. *A History of the Kennedy Space Center*. University Press of Florida, 2007 page 176.
- ³³ NASA. *Space Shuttle Launch and Recovery Site Review Board*. 1972.
- ³⁴ NASA, *Space Station Freedom Media Handbook*. 1992 page 1.
- ³⁵ <http://www.hq.nasa.gov/office/pao/History/taskgrp.html>.
- ³⁶ Honeycutt, Tim, Sowards Stephanie. *Integration Testing of Space Flight Systems (presentation)*. 2008.
- ³⁷ Robert C. Kline and Tovey C. Bachman.; *Estimating Spare Parts Requirements with Commonality and Redundancy*. 2006.
- ³⁸ Siddiqi, Afreen and de Weck Olivier L; *Spare Parts Requirements for Space Missions with Reconfigurability and Commonality*. 2006

-
- ³⁹ Crawley, Edward F., Wooster, Paul., Hofstetter, Wilfried K.; MIT Commonality Workshop. 2007
- ⁴⁰ Boas, Ryan C. and Prof. Crawley, Edward F.; Parallel and Sequential Development of Complex Platform-Based Product Families. 2007.
- ⁴¹ Monham, A.; Quigley, D.; Mission Operations Preparation Management: An Effective End-To-End Approach. IEEE Aerospace Conference Proceedings, 2004.
- ⁴² G. Chaudhri, S. Hollander.; Ground Systems - The Need for Standardization. AIAA Space Operations, 2004.
- ⁴³ Gilbert, Chris; van Leeuwen Wim.; Reducing the Cost Spacecraft Ground Systems and Operations Through Software Reuse., 5th International Symposium on Reducing the Cost Spacecraft Ground Systems and Operations, 2003.
- ⁴⁴ McKerracher Priscilla L., Tillman, David S., Furrow, R. Michael. Complete Ground Systems Software Re-use: The Common Ground Approach to a Re-usable, Shared Ground System. 2007.
- Leeha R. Herrera
- ⁴⁵ Boas, Ryan C. and Prof. Crawley, Edward F.; Divergence: The Impact of Lifecycle Changes on Commonality. 2007.
- ⁴⁶ G. Chaudhri, S. Hollander; Ground Segment Standardization and Commonality: Benefits, Risks and Obstacles. 2007.
- ⁴⁷ Herrera, L.; Tails of Developing a Common Ground Architecture. 2006.
- ⁴⁸ Egbett Norman F. and McKain, Theodore F.; Common Core Development Approach for Allison T406/AE Family of Turbohaft, Turboprop, and Turbofan Engines. 1994.
- ⁴⁹ Ney, Zane A and Looper, Christopher A.; Implementation Solutions for Integrated Maintenance and Logistics for Exploration Initiatives. 2005.
- ⁵⁰ Nadel, Miriam.; Ground systems standardization and commonality: Results from working group at Ground Systems Architecture Workshop (GSAW), 2007.
- ⁵¹ NASA Standard SP-2007-6105
- ⁵² NASA Standard SP-2007-6105.
- ⁵³ Benson, Charles D.; Faherty, William B. Gateway to the Moon. University Press of Florida, 2001 pages 173.
- ⁵⁴ Kelly, Thomas J. Moon Lander: How we developed the Apollo lunar module. Smithsonian Institution Press, 2001 pages 42, 96-97.
- ⁵⁵ Jenkins, Dennis R., Mars, Charles B., Capellin, Amador., Apollo Lunar Module KSC Processing White Paper R13. 2006.
- ⁵⁶ Kelly, Thomas J. Moon Lander: How we developed the Apollo Lunar Module. Smithsonian Institution Press, 2001 page 149.
- ⁵⁷ NASA, Apollo Experience Report – Ground Support Equipment. 1975 page 16.
- ⁵⁸ Jenkins, Dennis R., Mars, Charles B., Capellin, Amador., CSM White Paper R07. 2006.
- ⁵⁹ Benson, Charles D.; Faherty, William B. Moon Launch!. University Press of Florida, 2001 pages 359-364.
- ⁶⁰ Jenkins, Dennis R., Mars, Charles B., Capellin, Amador., CSM White Paper R07. 2006.
- ⁶¹ Benson, Charles D.; Faherty, William B. Gateway to the Moon. University Press of Florida, 2001 pages 174.
- ⁶² Benson, Charles D.; Faherty, William B. Gateway to the Moon. University Press of Florida, 2001 pages 174.
- ⁶³ <http://www.hq.nasa.gov/office/pao/History/taskgrp.html>.
- ⁶⁴ Letter from Debus to Meyers, February 13, 1970.
- ⁶⁵ Letter from Debus to Meyers, March 10, 1971.
- ⁶⁶ NASA; KSC-TR-1134: Proposed Concepts and Criteria For Ground Support and Facility Requirements to Support Space Shuttle Final Assembly and Flight Test. 1971.
- ⁶⁷ NASA; KSC-TR-1134: Proposed Concepts and Criteria For Ground Support and Facility Requirements to Support Space Shuttle Final Assembly and Flight Test. 1971.
- ⁶⁸ <http://www.openchannelsoftware.com/projects/SCAT/>.
- ⁶⁹ Smith, Marcia S., CRS Issue Brief 93017: Space Stations. 1996.
- ⁷⁰ NASA. ISS Joint Program Directive: Charter for International Space Station Program Support Equipment Control Board, 2001.
- ⁷¹ NASA. <http://standards.nasa.gov/public/public>. NASA-STD-5005.