

Wearable Technology

Amanda Watson

NASA CENTER

Major: Computer Science and Mathematics

Intern Summer Session

Date: 26 JUL 13

Wearable Technology

Amanda Watson
Drury University, Taylor Lake Village, TX, 77586

Abstract

Wearable technology projects, to be useful, in the future, must be seamlessly integrated with the Flight Deck of the Future (F.F). The lab contains mockups of space vehicle cockpits, habitat living quarters, and workstations equipped with novel user interfaces. The Flight Deck of the Future is one element of the Integrated Power, Avionics, and Software (IPAS) facility, which, to a large extent, manages the F.F network and data systems. To date, integration with the Flight Deck of the Future has been limited by a lack of tools and understanding of the Flight Deck of the Future data handling systems. To remedy this problem it will be necessary to learn how data is managed in the Flight Deck of the Future and to develop tools or interfaces that enable easy integration of WEAR Lab and EV3 products into the Flight Deck of the Future mockups. This capability is critical to future prototype integration, evaluation, and demonstration. This will provide the ability for WEAR Lab products, EV3 human interface prototypes, and technologies from other JSC organizations to be evaluated and tested while in the Flight Deck of the Future. All WEAR Lab products must be integrated with the interface that will connect them to the Flight Deck of the Future. The WEAR Lab products will primarily be programmed in Arduino. Arduino will be used for the development of wearable controls and a tactile communication garment. Arduino will also be used in creating wearable methane detection and warning system.

Nomenclature

Ω	= ohm, unit of electrical resistance
JSC	= Johnson Space Center, a NASA sight in Houston, Texas
EV3	= A division of Electronics Aviation dealing with Human Interface
IPAS	= Integrated Power, Avionics, and Software facility, where the Flight Deck of the Future is
F.F	= Flight Deck of the Future, test lab in the IPAS facility
WEAR	= Wearable Electronics Application and Research
Arduino	= Programming Language based in C that runs the Arduino circuit boards
TX	= Pin on the Arduino ¹ board and Xbee breakout board used for transmitting data
RX	= Pin on the Arduino board and Xbee breakout board used for receiving data
VCC	= Positive-voltage supply
GND	= Negative-voltage supply
JST	= Japan Solderless Terminals, used to integrate the lithium ion battery

I. Introduction

Wearable technology combines the functionality of electronics with the convenience of fabrics and clothing. Putting electronics on the body and making devices hands free will allow for higher efficiency, more productivity, and improvements in safety. Many challenges result from combining traditionally rigid electronics with the soft and flexible fabrics. Along with the technical challenges that stem from producing flexible and wearable electronics, wearable technology is a very vast field with many areas of expertise. There is a need for future collaboration between specialists so that new and more advanced devices can be created.

II. Manufacturing Process

To successfully integrate circuits into the garments, a specific manufacturing process is used. All circuits should be implemented off of the garment before trying to integrate them. First the circuit should be laid out on the desktop, diagramed, and programmed. After a diagram of the circuit is created, the circuit should be modified so that no wires cross. Conductive thread should not overlap in a circuit as the different threads are exposed and could cross signals. Then the circuit should be sewn onto the garment, testing the components as they are sewn in. Once all components are working, bind all of the edges and do not leave unnecessary conductive threads exposed.

III. The Basic Circuit

The basic circuit to be used in most WEAR Lab products uses an Arduino Pro Mini board, a Xbee radio², a lithium ion battery, JST connector and switch, and conductive thread to connect the components. The Arduino Pro Mini Board³ is a small and light circuit board that has fourteen digital input/output pins and eight analog inputs. The pins are through hole solder points which allows for wrapping thread through the through hole and tying it off or soldering it. The board must connect to power and ground through the pins labeled VCC and GND.



Mini



Xbee radio
mounted on a
LilyPad Xbee
breakout board

Xbee radios allow for wireless communication from the garment to the computer. A LilyPad Xbee breakout board⁴ has power regulation and easy to sew to tabs to make integration into a garment simple. A LilyPad Xbee breakout board must be connected to power, ground, TX, and RX to power the board and provide communication between the Arduino Pro Mini Board and the computer.

To construct the circuit, use a lithium ion battery as a power source and a JST connector and switch to connect the battery to the circuit and turn the circuit on and off. Connect the power from the JST connector to the VCC pin on the Arduino Pro Mini board. Then connect the ground from the JST connector to the GND pin on the Arduino Pro Mini board. When switched on, this will provide power to the board. Next connect the “+” on the LilyPad Xbee breakout board to the VCC on the Arduino Pro Mini board and the “-” to the ground. Now all boards in the circuit should be powered. To connect the wireless communication feature of the Xbee radio, connect the TX and RX pins on the LilyPad Xbee breakout board to two digital pins. When programming the Arduino board, use the Software Serial library to define these two digital pins as a TX and a RX. The TX on the LilyPad Xbee breakout board should connect to the RX on the Arduino Pro Mini board. The RX on the LilyPad Xbee breakout board should connect to the TX on the Arduino Pro Mini board. The Arduino Pro Mini board has predefined RX and TX pins but if they are in use while reprogramming the board, an error will be thrown.

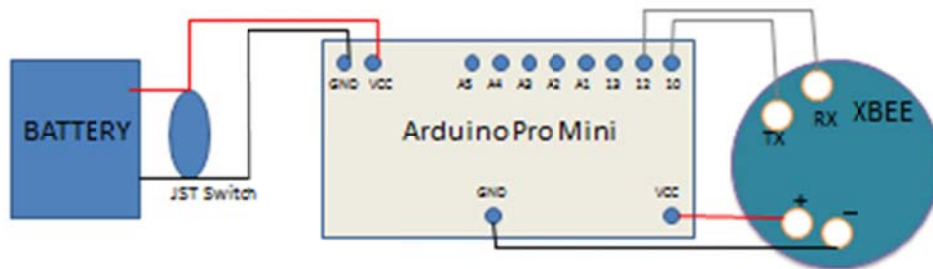

IV. Wireless Communication

Wireless communication is important in wearable technology because it is important to have freedom to move when using a garment. There are two commonly used wireless communication methods from a device to a computer. These methods are Xbee radios and Bluetooth.

Xbee radios are large and bulky when compared to the other methods and they also require a large breakout board. The large breakout board makes the Xbee radio easier to integrate into the garment as it is easier to sew through the solder points and around the board. Xbee radios are the simplest to integrate and if you provide them with a power source the



Xbee radio This
all of the
s but the
eter

radios will immediately connect with each other.



Figure 3. Bluetooth device
This chip is used in the accelerometer forearm sleeve

Bluetooth chips are small and flat and the breakout boards are small and linear making them easier to integrate. Each Bluetooth device, when connected to the computer needs its own virtual serial port. To use multiple Bluetooth chips concurrently, the user must open each serial port separately, this can become very time consuming. Bluetooth chips also frequently disconnect from the computer and are not very reliable.

V. Wearable Controls

To pursue research in wearable technology, a first step is to explore the methods and mechanisms of basic electronic structures integrated into garments. Four different controls to pursue are buttons, pressure sensors, capacitive touch sensors, and an accelerometer. These controls were chosen because they are all available in the lab and they can all be used to perform the same tasks. The controls can be used to interact with applications on the computer. Each control presents its own advantages, disadvantages, and complications. To easily test the controls and allow the user comfortably change between the control garments, the electronics will be integrated into forearm sleeves.

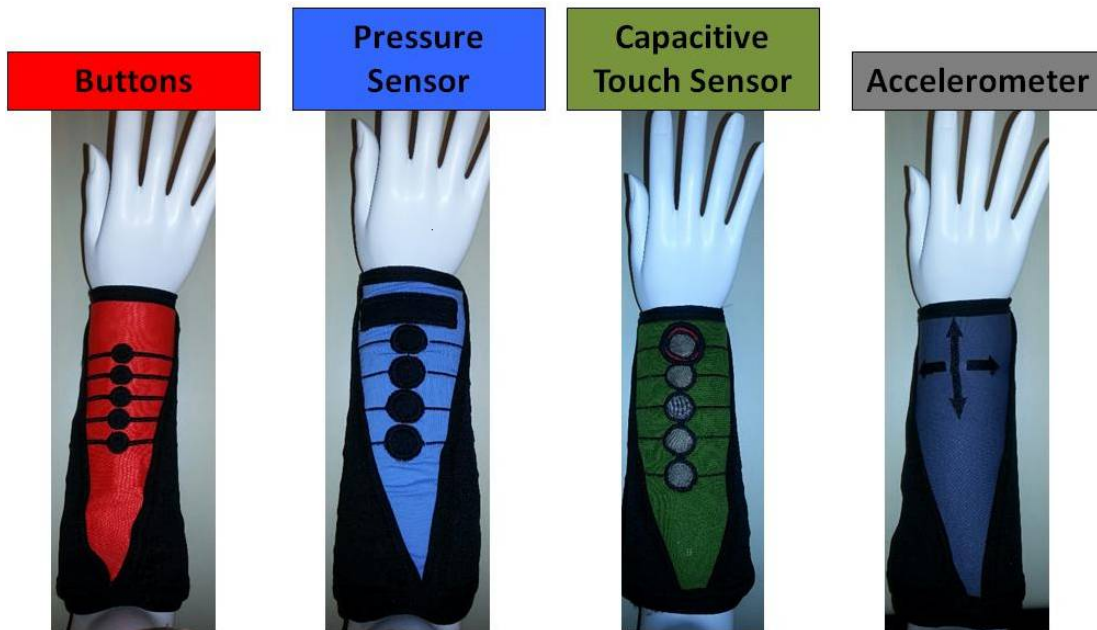

Figure 4. The 4 Wearable Controls from right to left, they are the Buttons Control, the Pressure Sensor Control, the Capacitive Touch Sensor Control and the Accelerometer Control

A. Buttons

Buttons are the most widely used and familiar of the controls. Buttons can be implemented on separate pins or if the buttons have varying resistances, in parallel. A parallel circuit of buttons will use a single analog pin and ground, while individual buttons will each need their own digital ports and can share a ground. The string of buttons used in the garment is Fibretronics Lite Keypad⁵. These buttons are encased in a soft rubber which allows for more flexibility when integrated into the forearm sleeve. The buttons are also lightweight so that the user will not be affected by the weight. When pressed the buttons provide the user with tactile and auditory feedback.



Figure 5. Fibretronics Lite Keypad these are the buttons integrated into the button forearm sleeve

The Fibretronics Lite Keypad is set up so that the 5 buttons are in a parallel circuit. Each button, when pressed will output a different resistance. To integrate this control into a forearm sleeve, create a voltage divider with the string of buttons and a resistor. Connect one side of the voltage divider to power and the other to ground. In the middle, where the buttons and the resistor connect, connect to an analog input pin. The analog input pin will read the different resistances and can interpret the buttons separately.

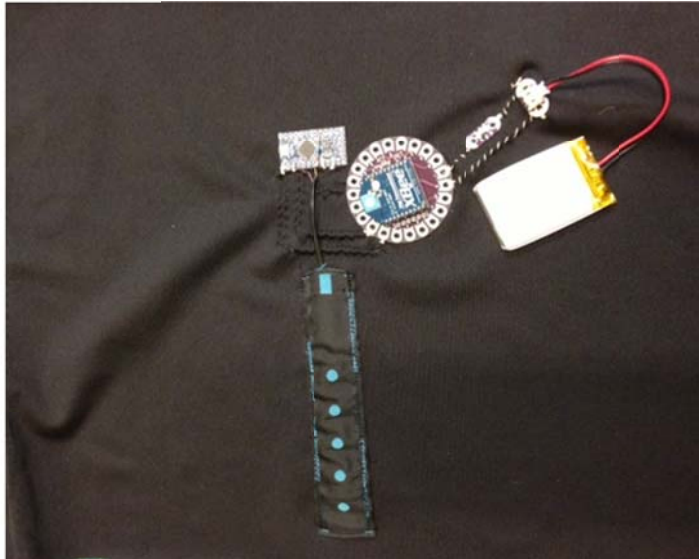
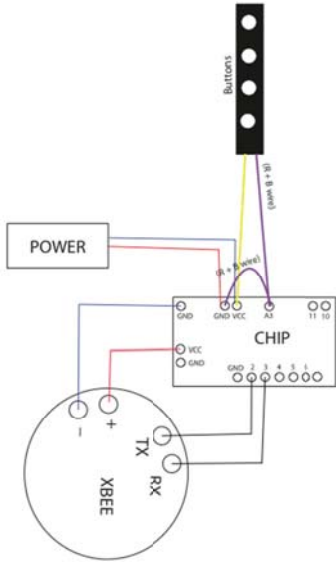

Figure 6. Buttons Circuit Diagram

B. Pressure Sensor

Pressure sensors are flexible, thin, and lightweight which allow for almost seamless integration into the forearm sleeve. Pressure sensors can detect varying degrees of pressure which gives the pressure sensor more functionality than just on and off. To set up a pressure sensor as an on and off button, set a threshold, that once the value exceeds that threshold the sensor will register on.

To read a value from the variable pressure sensor, create a voltage divider with the variable pressure sensor and a resistor. Connect one side of the voltage divider to power and the other to ground. In the middle, where the variable pressure sensor and the

resistor connect, connect to an analog input pin. The analog pin will read a value from 0 to 1023. To set up a pressure sensor as an on/off button, set a threshold or the pressure sensor value and once the value exceeds the threshold the device will register on. When integrating the pressure sensor, it can be put onto any layer within the garment, as it does not need direct contact. But with it sensing pressure, errors and mishaps could stem from accidental activation of the sensors. To try to limit these instances, a safety pressure sensor is integrated. To be able to use the other pressure sensors the user must concurrently be activating the safety pressure sensor.



Pressure Sensor

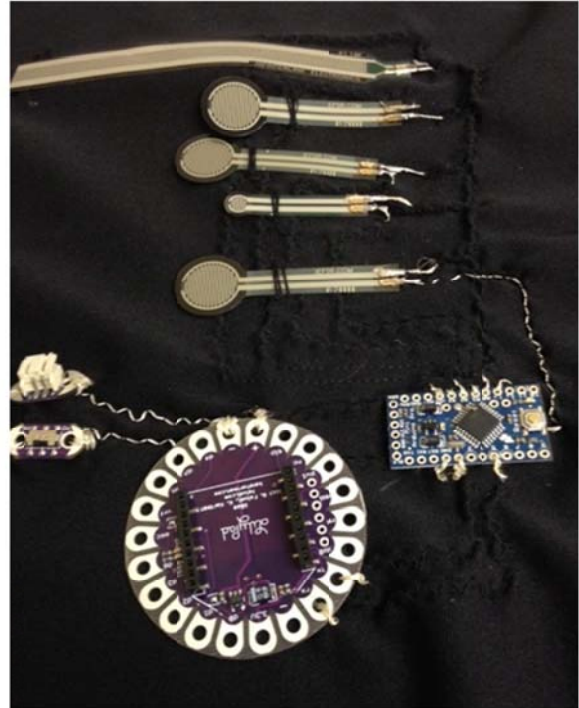
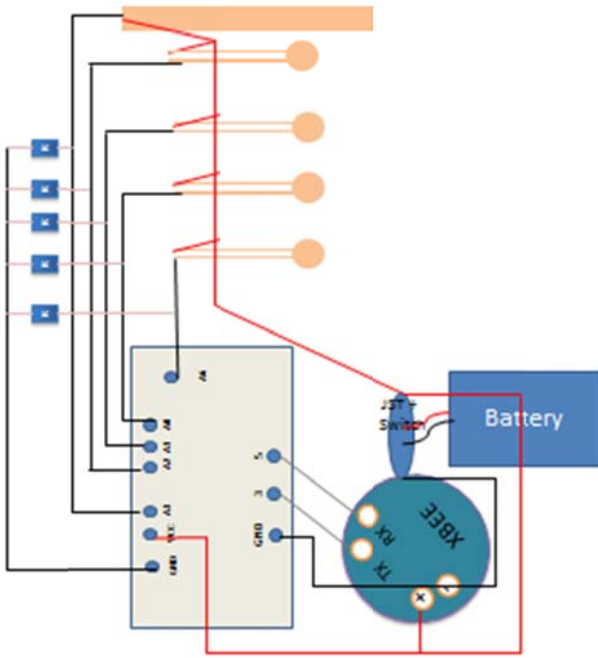

Figure 8. Pressure Sensor Diagram

C. Capacitive Touch Sensor

Capacitive touch sensors can be made with either conductive thread or conductive fabric. Since the sensor itself is made of a soft flexible material, it can be integrated seamlessly into the forearm sleeve. This control can be made into varying shapes and designs. The sensor can either be made with conductive fabric or embroidered with conductive thread. These sensors do not provide any auditory feedback but the user will be able to locate the sensor easily since the conductive fabric or embroidery has a different texture than the nonconductive fabric. Capacitive touch sensors are most appropriate when a force cannot be applied or no force is needed to control a garment. Capacitive touch sensors run the risk of a conductive material touching the sensors and activating. To try to limit errors and mishaps that could stem from accidental activation of the sensors, a safety capacitive touch sensor is integrated. To be able to use the other pressure sensors the user must concurrently be activating the safety pressure sensor

Conductive thread can be embroidered or sewn into a garment to create a capacitive touch sensor. The conductive thread should be embroidered or sewn in a design such that there are two separate sides. When the entire conductive thread design is covered the user will have completed the circuit. To construct a circuit for the conductive thread capacitive touch sensor, a sense will be used. The sense pin will be a digital pin that registers a high or low value. One side of the capacitive touch sensor will be connected to power and the other connected to sense pin. To account for an electrostatic shock, a resistor of about 1000 ohms should be placed before the sense pin. This pin will register the change in voltage from high to low when the circuit is complete.



ed
sor

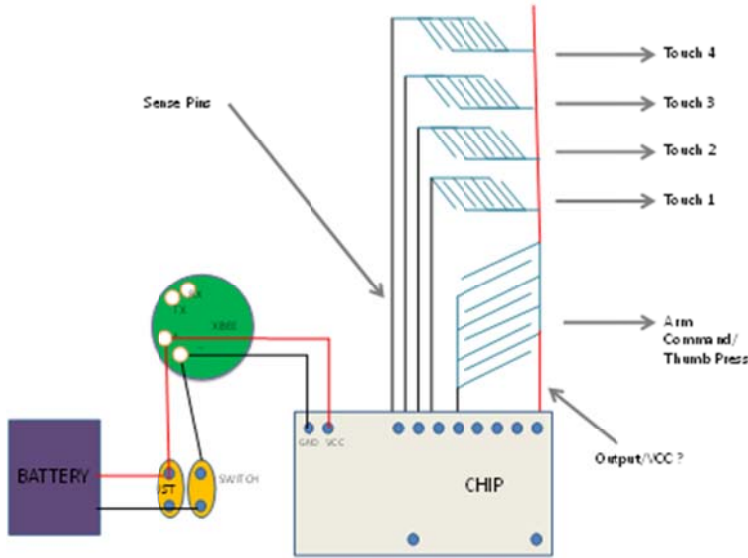

Figure 11. Embroidered Capacitive Touch Sensor Diagram

Conductive fabric can be sewn into a garment to create a capacitive touch sensor. To read a value from the capacitive touch sensor, a send pin and a receive pin will be used. When the send pin changes to a new state, a counter begins and continues to count until the receive pin's state changes. Count is an arbitrary unit but it allows the user to read a change in the capacitance of the sensor. To integrate the fabric with the electronics conductive thread should be sewn around the edges of the fabric and then connected to sense and receive pins. The setup of this circuit will require a 100 kilohm – 50 megohm resistor between the send pin and the receive pin. Adjusting this resistor changes the sensitivity of the sensor; the smaller resistors will require touching the sensor while the larger resistor can activate while inches away from absolute touch. This would allow the sensor to activate through other layers of fabric. The smaller sensors have a much faster response time than the larger resistors. To account for an electrostatic shock, another resistor of about 1000 ohms should be placed before the receive pin.

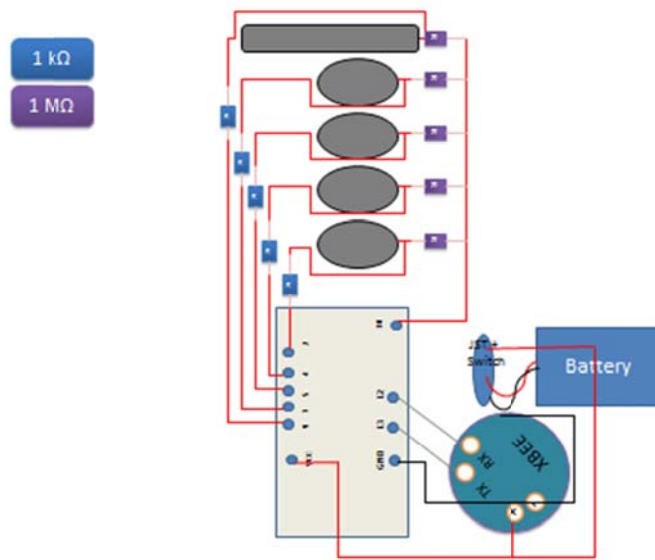
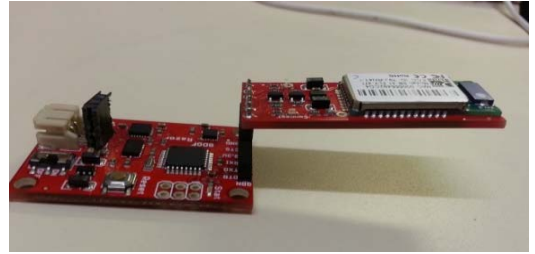

Figure 12. Conductive Fabric Capacitive Touch Sensor Diagram

D. Accelerometer

Accelerometers are hands free devices that rely on movement. The hardware is small and light but not flexible. This accelerometer outputs yaw, pitch, and roll. From those values many different gestures can be derived. For the test interfaces it was important to be able to measure the movement of a forearm since it was implemented in a forearm sleeve. The movement used are pointing the wrist up, pointing the wrist down, turning the wrist to the right, and turning the wrist to the left. Gesture control should be studied to discover the most intuitive and least tiring movements to use.



VI. Testing

To test each of the four wearable controls' ability to complete common task four test interfaces were built. The controls were rated on their ease of use, functionality, and accuracy.

A. Phone Call

Answering a phone call was the first and simplest demo. The user would be asked to answer a phone call and then hang up the phone. For the buttons and sensors, these actions would be mapped to two separate buttons. For the accelerometer, turning the wrist to the left would answer the phone call and turning the wrist to the right would end the phone call. This demo would prove that the user can easily associate the buttons or movement with the actions that happened on the interface.

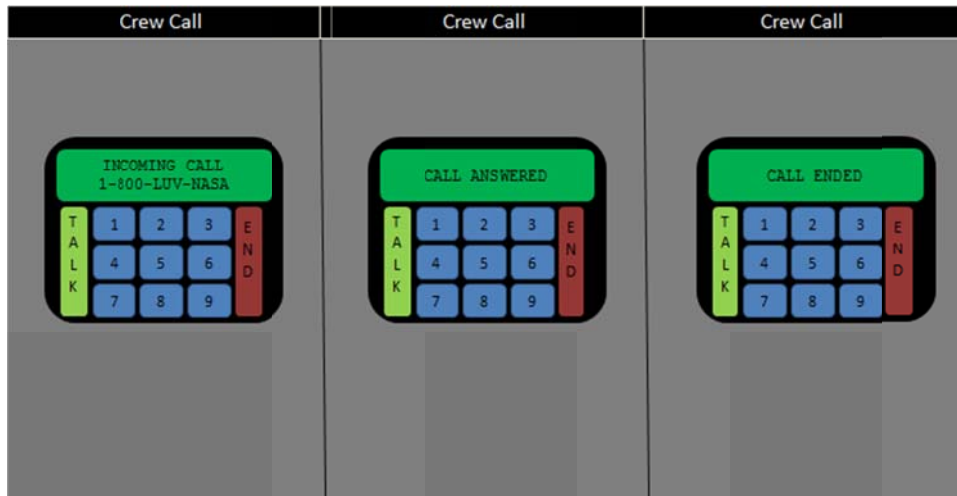
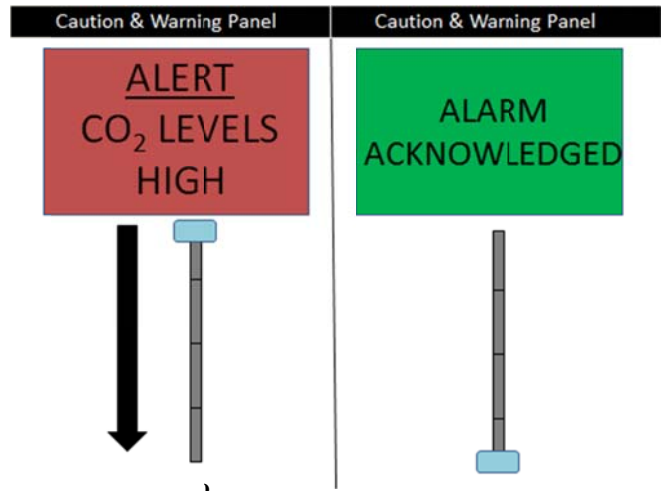

Figure 14. Phone Demo

B. Caution and Warning Alarm

The second demo was a caution and warning alarm. The user would be asked to hit a sequence of buttons in a specified order to be able to deactivate the alarm. For the buttons and sensors, these actions would be mapped to the top 4 buttons. For the accelerometer, pointing the wrist down would move the paddle until the alarm was turned off. This demo would prove that the user can easily remember and use a sequence of buttons.



C. Navigation

The third demo was a navigation task. The user would be asked to navigate the paper airplane to the thrash. The movements of the paper airplane are up, down, right and left. For the buttons and sensors, these actions would be mapped to the top 4 buttons. For the accelerometer, pointing the wrist up would move the airplane up. Pointing the wrist down would move the airplane down, turning the wrist right would move the airplane right, and turning the wrist left would move the airplane left. This demo would prove that the user can easily remember a specified set of keys and can use those keys easily.

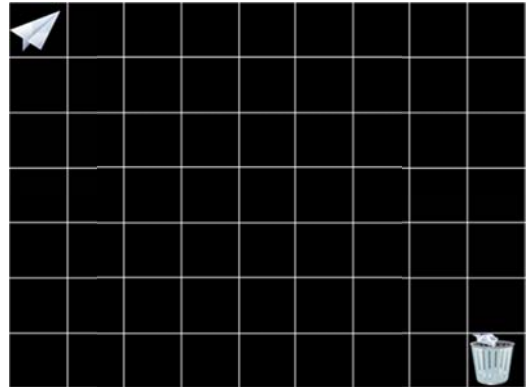

D. Space Invaders

The fourth demo was a space invaders game. The user would be asked to move a ship right and left and shoot at invaders. This demo places a time limit on the user, so that if the controls are not simple to learn, the user will not finish the demo in the time constraints. For the buttons and sensors, these actions would be mapped to the top 3 buttons. For the accelerometer, pointing the wrist up would shoot, turning the wrist to the right would move the ship right and turning the wrist left would move the ship left.

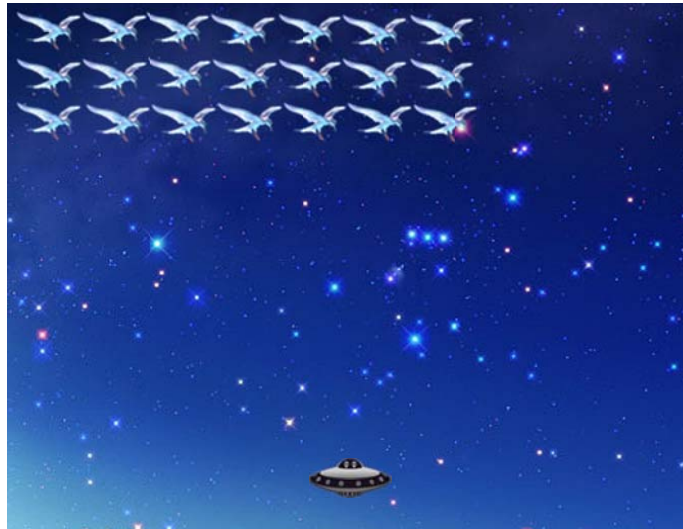

VII. Conclusion

Overall the layout of the controls on the forearm sleeves needed to be changed. Users with smaller hands were not able to reach all of the buttons and sensors. The forearm sleeves in general were uncomfortable and new ways of keeping the electronics covered and hidden should be explored. The forearm sleeves should be smaller and more breathable in the future. However the design of the forearm sleeve kept people from feeling the electronics in them.

Each wearable control had its own set of pros and cons. The buttons were small and required a lot of force to activate. The circuit design for the buttons was simple and the flexibility integrated well into the garment. The buttons also produced tactile and auditory feedback when pressed which was helpful when working through the demos and troubleshooting. The pressure sensors were easy to use and very well integrated but tactile and auditory feedback was preferable. Attempting to hold the safety sensor while using the other sensor was a challenge. The safety should be moved to allow those with smaller hands to be able to access it easier. The capacitive touch sensors were easy to find on the garment because of the differences in fabric. They were also more efficient then the other

controls as they do not need pressure to be activated. The accelerometer was useful for all of the tasks but after working with it for a period of time, it would become tiring.

For future integration into garments a combination of these controls would create a more efficient and functional garment. A form of tactile feedback such as small vibrating motors should be integrated so that the user knows when they have activated a sensor. This would also be useful for troubleshooting which components in the system are working and which components are not working. Overall proving that these different wearable controls are functional and knowing the advantages and disadvantages will be very beneficial to the WEAR Lab in its future research and design projects.

Acknowledgements

Amanda Watson would like to thank Cory Simon for mentoring her throughout her entire internship and supplying her with all of the equipment she needed to complete her projects. He was an outstanding and helpful mentor. Mary Berglund for sewing and designing the garments. Traci Thomason for supplying her with the necessary information about the various controls to complete her projects. She also would like to thank John Burczak, Patricia Conway, and Doris Weber for making this internship possible through support and funding. She would also like to thank her professors at Drury University who encouraged her to work through all forms of challenges and puzzles and, finally, she would like to thank her family, without whom none of this would be possible.

References

- ¹ "Arduino" Arduino Team,
<http://www.arduino.cc/en/>
- ² "XBee® 802.15.4 Device connectivity using multipoint wireless networks", Digi,
<http://www.joystiq.com/2010/06/19/kinect-how-it-works-from-the-company-behind-the-tech/> Overlay
- ³ "Arduino Pro Mini", Arduino Team,
<http://arduino.cc/en/Main/ArduinoBoardProMini>
- ⁴ "Lilypad Xbee Breakout Board", Sparkfun Electronics,
<https://www.sparkfun.com/products/8937>
- ⁵ "Lite Keypad, Fibretronics Ltd,
<http://fibretronic.com/connectedwear/KP24G>