



# Tank Applied Testing of Load-Bearing Multilayer Insulation (LB-MLI)

Wesley Johnson<sup>1</sup>, Juan Valenzuela<sup>2</sup>, Jeff Feller<sup>3</sup>,  
Dave Plachta<sup>1</sup>

<sup>1</sup>Glenn Research Center

<sup>2</sup>Marshall Space Flight Center

<sup>3</sup>Ames Research Center

2014 Propulsion and Energy Forum

Cleveland, OH

July 28 - 30



## Reduced Boil-Off

- For long duration storage of cryogenic propellants on orbit, boil-off is a significant problem
  - Reducing the boil-off through active refrigeration may be required if passive insulation systems cannot be built to meet mission requirements
- Lack of large scale 20 K class cryocoolers limits our current availability to do zero boil-off for liquid hydrogen
- Incorporating existing 90 K cryocoolers could still lower heat load by as much as 70% (theoretical)
  - Use a Broad Area Cooling (BAC) shield, similar to a vapor cooled shield, but attached to a cryocooler
  - Cool struts and plumbing in addition to insulation system

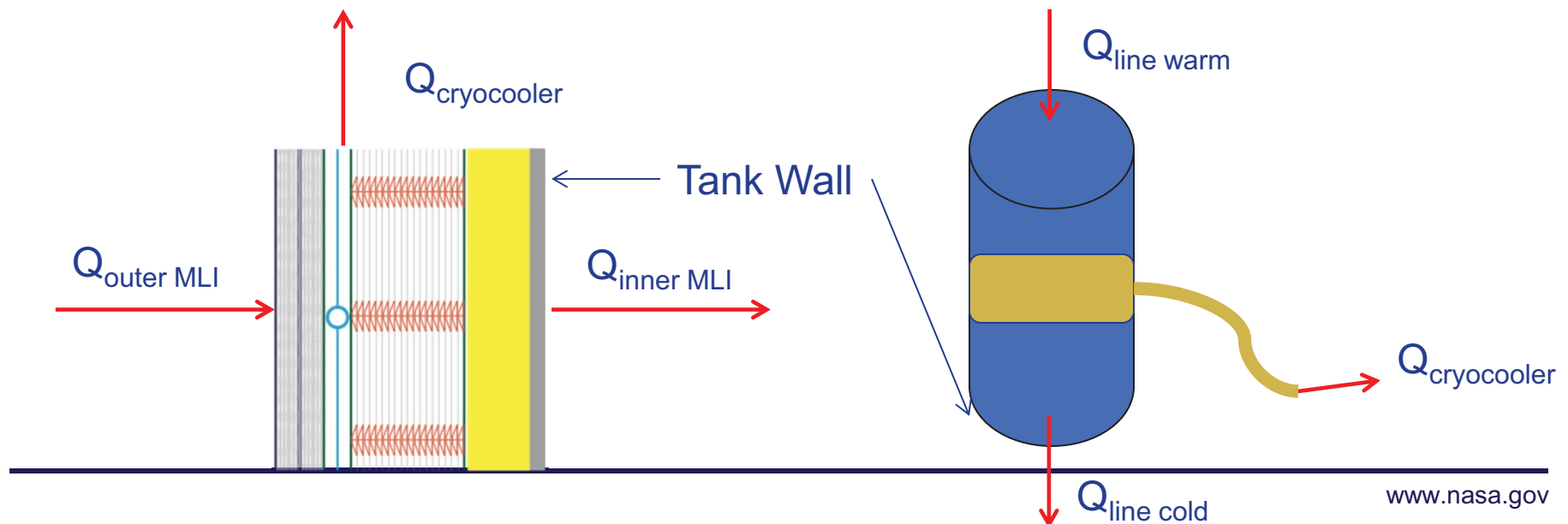



# Problem Statement

- Demonstrate a system that can:
  - Support a Broad Area Cooling shield in the middle of an MLI blanket
  - Survive launch loads
  - Provide high thermal performance on orbit
  - Survive rapid depressurization
- Solution:
  - Load-Bearing Multilayer Insulation
    - Built by Quest Products & Ball Aerospace
    - Developed through several SBIR contracts



# Load Bearing Multilayer Insulation

- Uses polymer based stand-offs to separate the layers as opposed to netting
  - Creates a simpler conduction heat transfer network for modeling
  - Allows for more accurate modeling of MLI system
- Can be arranged to provide structural support via stacking spacers
  - Previous testing used plastic stand-offs to support BAC shield
  - No stand-offs required with LB-MLI
- Currently at low (5 layer/cm) layer density
  - Based on current MLI theory, about optimum for 90 – 100 K warm boundary
  - Replaced 30 layer traditional blanket with 19 layer LB-MLI blanket

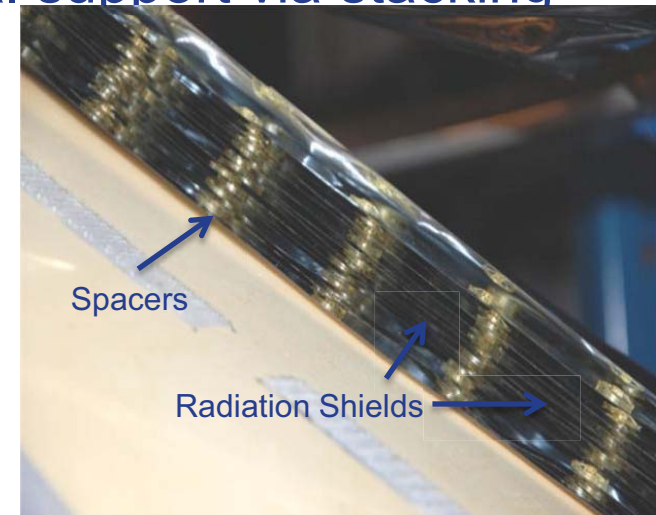



# Test Program

Two tanks were fabricated to be as close to identical as possible

- Nearly identical insulation systems were installed on each tank
- One tank was tested with liquid hydrogen for thermal performance
- The other was tested with liquid nitrogen to determine the acoustic environmental effects on the cooled shield/MLI.





# Test Configuration

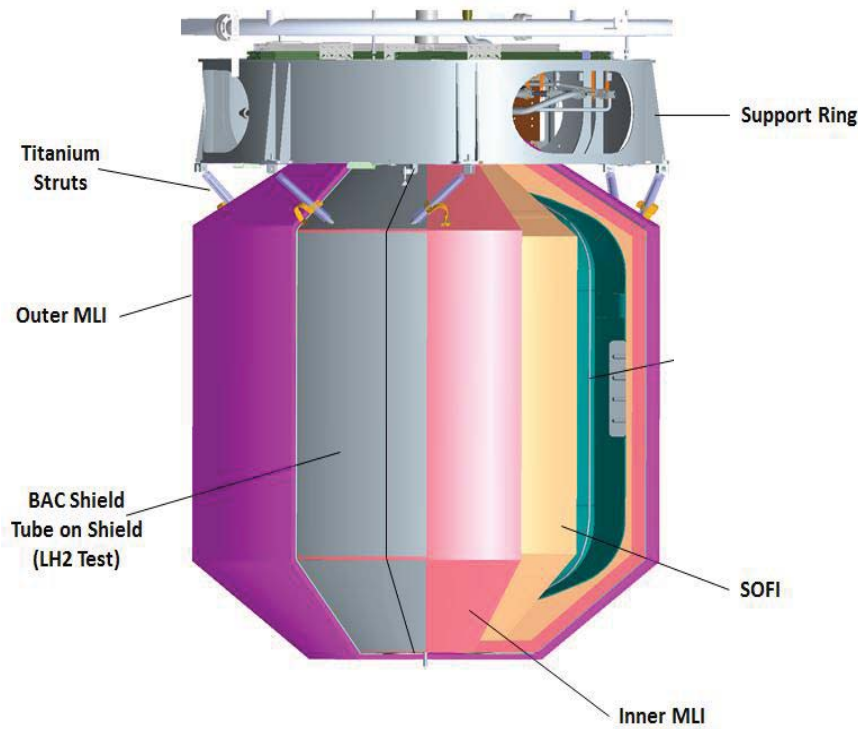

Layered cut-away view

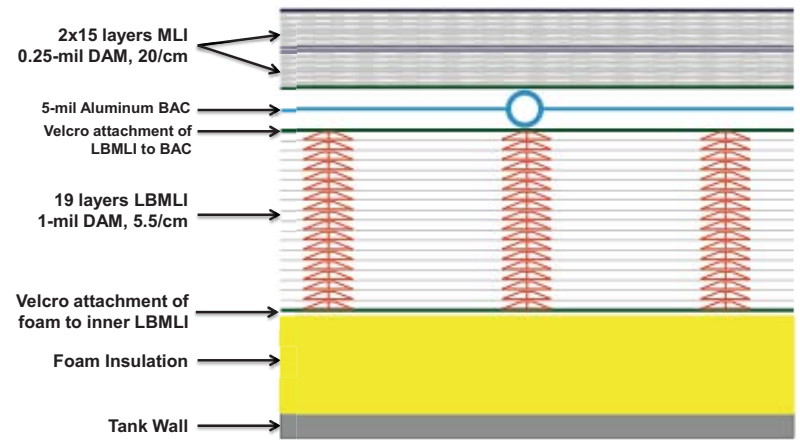

Cross-Sectional View



# Structural Testing

- In order to demonstrate structural integrity of the blanket, acoustic testing was selected over vibration testing
  - Insulation systems are large area, lightweight systems that respond more to acoustically input energy than vibrationally input energy
- Testing on coupons
  - Unloaded flat panel
  - Loaded curved panel
  - Post test examination for changes (damage)
- Testing on a Tank
  - Thermal testing before and after
  - Post test examination for changes (damage)
- All actual acoustic testing done when system was a room temperature

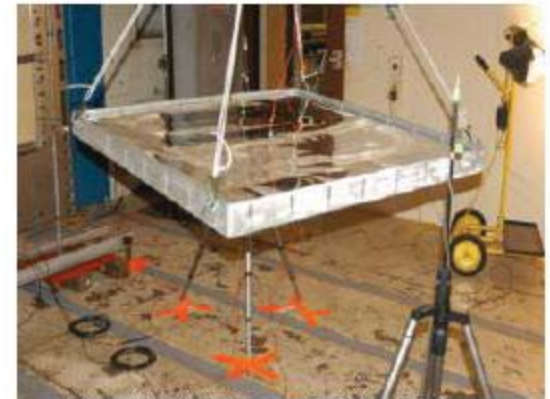



# Coupon Test Results

- The dotted black line indicates input levels
- Colored squiggly lines indicate response
- Flat panel test (top)
  - Just LB-MLI, no load attached (i.e. BAC shield, other MLI)
  - Post test inspection revealed no issues (debonding, tearing, etc)
  - Indicated that LB-MLI can survive launch & ascent with no external load
- Curved panel test (bottom)
  - Included BAC shield mass simulator and outer MLI
  - Post test inspection revealed no issues
  - Indicated that LB-MLI can survive launch & ascent with load attached
- Both tests combined indicated that LB-MLI was ready to proceed with tank applied testing

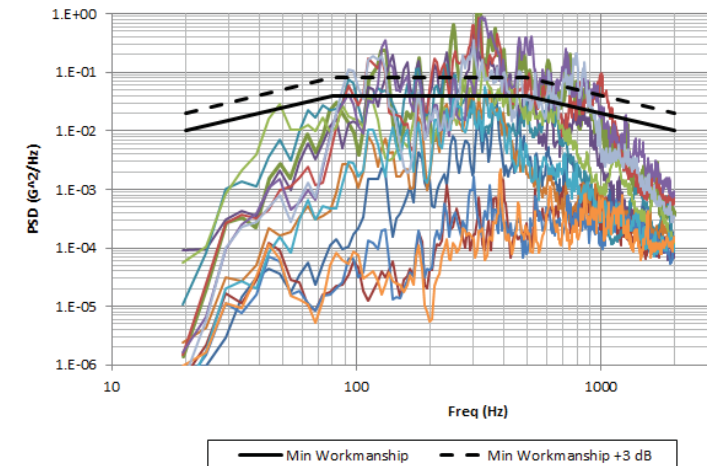
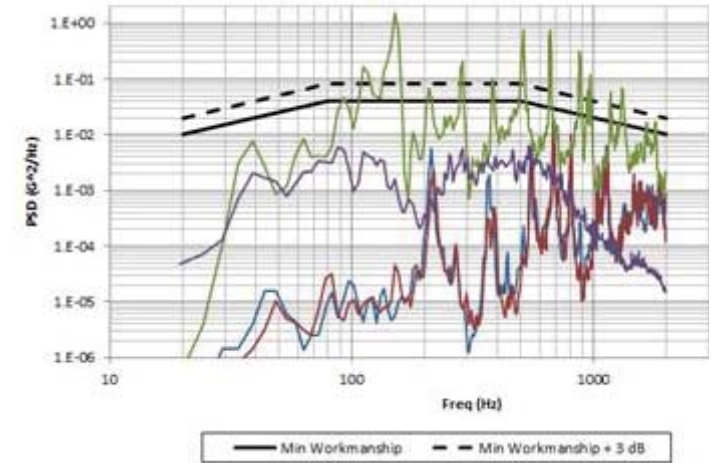





# Tank Applied Test Setup

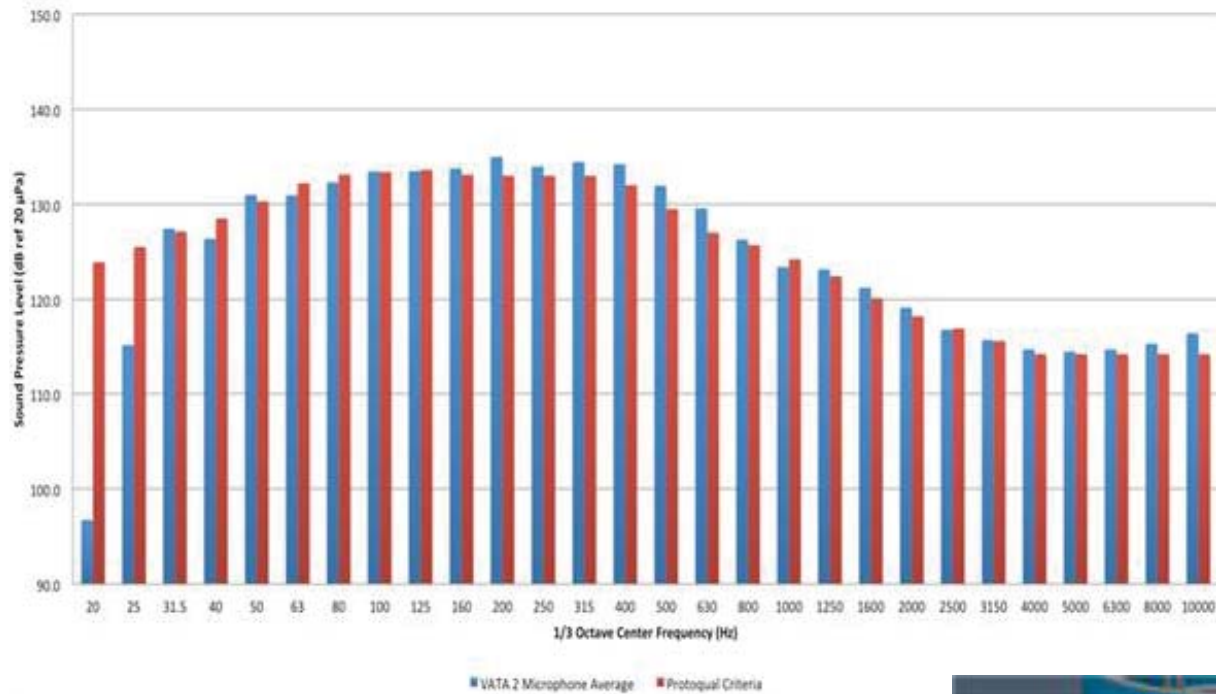

Accel #	Description	Type
1	On gusset, near strut attach point	Triax
2	On tank, near strut attach point	Triax
3	On support column, top surface	Triax
4	On tank surface, mid-barrel section	Uniaxial
5	Same as #4, clocked 120 degrees around tank	Uniaxial
7	On top of tank	Uniaxial
8	On bottom of tank	Uniaxial
9	On gusset, near strut attach point	Triax
10	On tank, near strut attach point	Triax





# Tank Applied Acoustic Testing Results

- Pre and Post Test Thermal testing using LN2
  - Heat load of 7.5 W on both tests
  - When running chilled GN2 through BAC shield tubing, heat load of 4.5 W on both tests
    - No gas leaks in tubing degrading performance
- Post test inspection found no issues
  - No debonding of spacers, no tears of MLI, no warping of MLI blanket
- Maximum acceleration level on BAC shield: 8.7  $G_{RMS}$ 
  - Original level for concern was 6  $G_{RMS}$
  - After no damage found, at 8.7 $G_{RMS}$ , level of concern was upped to 10  $G_{RMS}$

VATA 2 Full Scale Tank Test	
Accelerometer	GRMS
R1R	1.498
R1L	1.551
R1T	0.867
R2R	4.709
R2L	1.31
R2T	0.728
R3R	1.24
R3L	1.089
R3T	2.982
R4R	6.407
R5R	3.041
R7L	3.061
<b>R8L</b>	<b>8.697</b>
R9R	2.051
R9L	1.576
R9T	0.991
R10R	5.22
R10L	1.046
R10T	0.769

BAC Shield Response

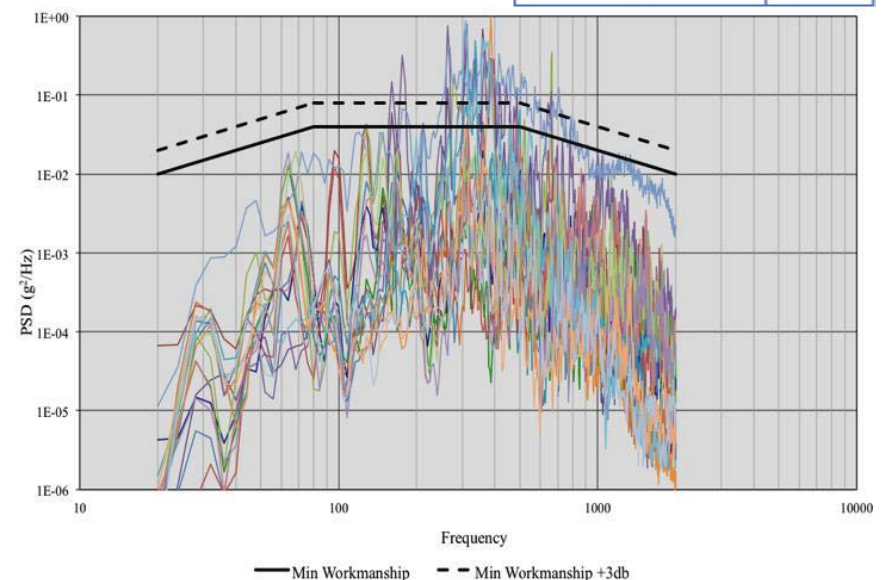
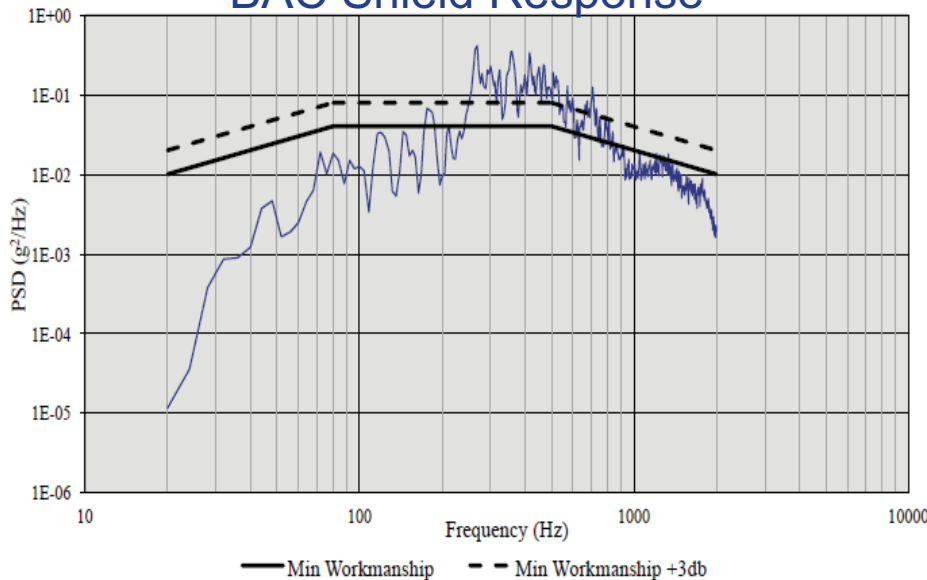



# Thermal Testing

- In order to demonstrate thermal viability, a thermal vacuum test was run using liquid hydrogen
  - Broad Area Cooled (BAC) Shield was integrated on top of the blanket
  - BAC shield was coupled to a cryocooler
  - Testing with and without cryocooler operational
- Pre-test coupons were tested using liquid nitrogen

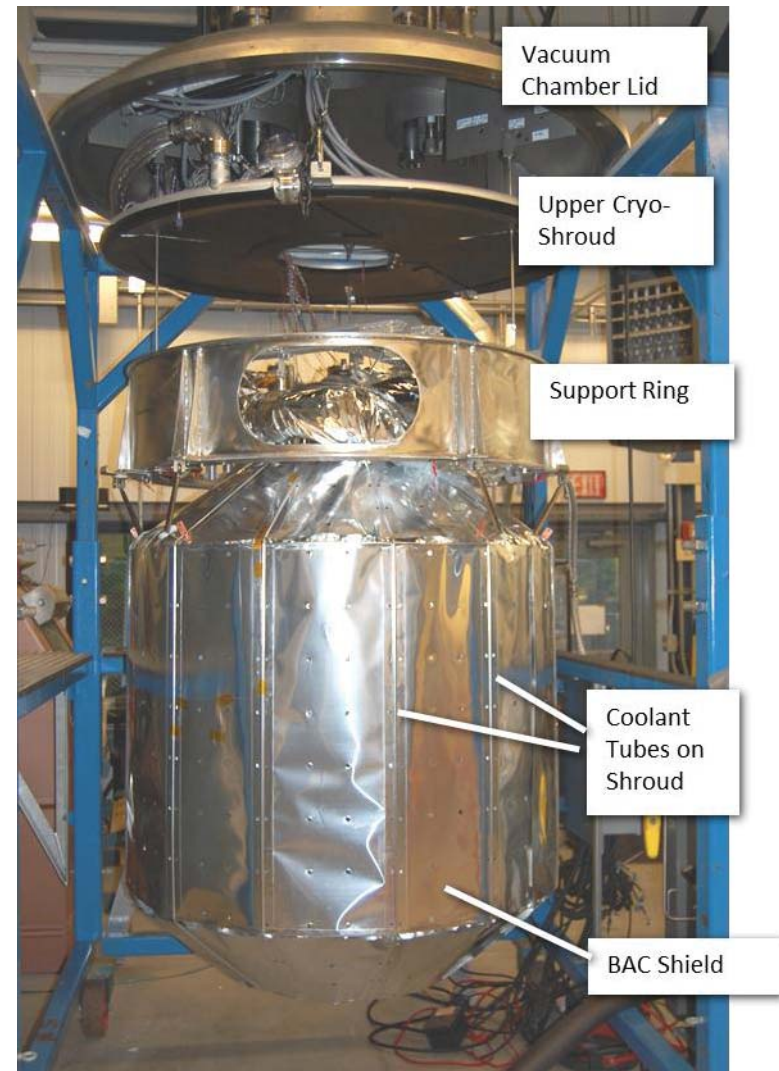



# Thermal Coupon Results

	layers	Tc, K	Th, K	Measured Q, W/m <sup>2</sup>	Model Q, W/m <sup>2</sup>	% difference	SF
Ball	10	76	296	0.95	0.91	-4.3%	1.05
KSC	20	77	292	0.41	0.43	5.6%	0.95
KSC	20	77	305	0.57	0.51	-11%	1.12
Ball	3	76	296	3.62	3.02	-16%	1.20
KSC	9	78	293	0.92	0.97	5.2%	0.95
	9	78	325	1.36	1.41	4.0%	0.96
	9	78	316	1.23	1.28	3.5%	0.97
KSC	5	78	293	1.77	1.75	-1.3%	1.01
	5	78	305	1.99	2.02	1.5%	0.99
	5	78	325	2.61	2.54	-2.6%	1.03
KSC	19	78	293	0.55	0.46	-16%	1.18
	19	78	305	0.77	0.51	-34%	1.51
	19	78	327.8	0.85	0.69	-19%	1.23
FSU	4	20	85	0.18	0.11	-42%	1.71
	9	20	85	0.13	0.048	-63%	2.71

$$Scale\ Factor = \frac{Q_{MLI,test}}{Q_{MLI,predict}}$$



# Tank Applied Thermal Test Matrix

Test #	BAC Set (K)	Shield Point	Bypass Valve (open/closed)	Fill Level (%)	Environmental Temperature (K)	Test Type
1	80 K		Open	90	220	Steady State
2	80 K		Open	25	220	Steady State
3	N/A		Open	90	220	Steady State
4	N/A		Closed	90	220	Steady State
5	90 K		Open	90	220	Steady State
6	90 K		Closed	90	220	Steady State
7	N/A		Open	90	300	Rapid Evacuation
8	N/A		Open	90	300	Steady State

Note: Bypass Valve was to allow for testing with and without Thermo-Acoustic Oscillations (TAO)



# Tank Applied Thermal Test Results

Test #	Heat Load to Tank (W)	Conduction Heat Loads (W)	Net Remainder (W)	MLI Penetrations (W)	MLI Heat Load (W)	MLI Heat Flux (mW/m <sup>2</sup> )	Predicted MLI Heat Flux (mW/m <sup>2</sup> )
1	1.67	0.94	0.73	0.17	0.56	79	19
2	1.68	0.97	0.71	0.17	0.54	76	17
3	3.32	1.69	1.63	0.17	1.46	207	116
5	1.83	1.01	0.82	0.17	0.64	92	21
8	6.12	2.77	3.35	0.28	3.07	436	310

$$Scale\ Factor = \frac{Q_{MLI,test}}{Q_{MLI,predict}}$$

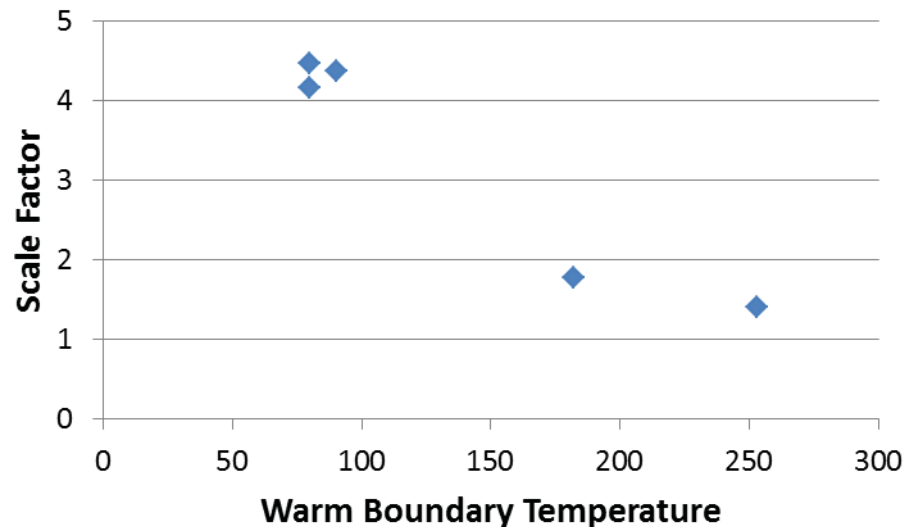



# Rapid Depressurization

- Rapid Depressurization was performed
  - Simulates the first few minutes to hours of mission
  - Attempted twice, both times got through the rough pumping portion but had trouble switching to turbo/diffusion pumps
    - Issues with gaseous nitrogen evacuation due to the formation of solid nitrogen at the bottom on the MLI blanket
  - Attempted with helium gas and was fully successful



## Post Test Evaluation

- Post test evaluation showed divoting and cracking of the SOFI, further investigation yielded:
  - Tank was stainless steel, not aluminum, SOFI shrinkage optimized for aluminum
  - SOFI was up to 4" thick in some places, recommend not greater than 1.5" to 2" thick in future
  - Velcro may have added extra stresses to cause more cracking

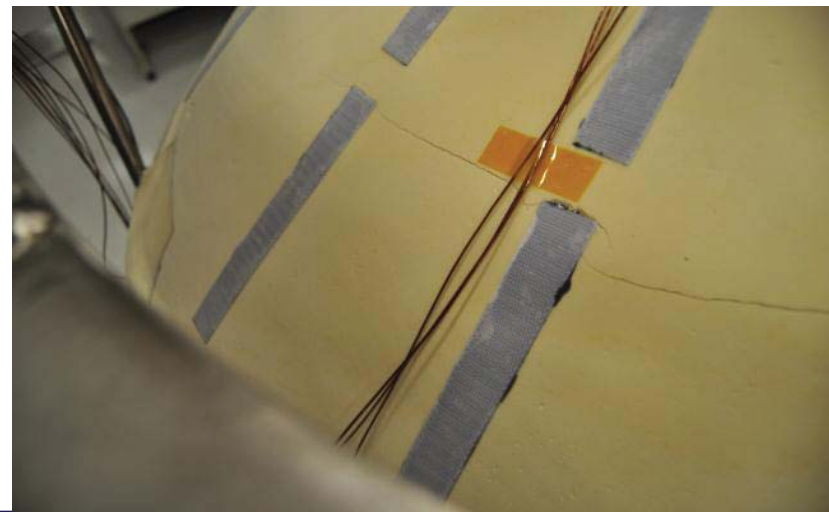





## Conclusion

- Demonstrated a system (LB-MLI) that can:
  - Support a Broad Area Cooling shield in the middle of an MLI blanket
  - Survive launch loads
  - Heat load of less than  $0.1 \text{ W/m}^2$  through the MLI with the cryocooler on and  $0.2 \text{ W/m}^2$  with the cryocooler off.
  - Survive rapid depressurization
- Noticed increasing scale factor with decreasing temperature, first cut analysis indicates it is a radiation issue
  - This is not an LB-MLI specific problem
  - Was worse on previous traditional MLI blanket testing
- SOFI had issues handling combined loads during rapid depressurization
  - partially a design issue
  - more investigation needed to fully understand



## Acknowledgments

- The Small Multipurpose Research Facility Test Team (Glenn Research Center – Tank Applied Thermal Testing)
- Bldg 4619 Acoustic Chamber Test Team (Marshall Space Flight Center – Acoustic testing)
- Environmental Systems Test Facility Test Team (Marshall Space Flight Center – Pre/Post-Acoustic Thermal Testing).
- Funding was provided by both the:
  - Cryogenic Propellant Storage and Transfer Technology Demonstration Mission
  - Self-Supporting Multilayer Insulation Project (STMD Game Changing Division)



# Questions?

