



NASA Electronic Parts and Packaging (NEPP) Program

Effect of Preconditioning and Soldering on Failures of Chip Tantalum Capacitors

NEPP task 2014

Alexander Teverovsky
Parts, Packaging, and Assembly Technologies
Office, Code 562, GSFC/ ASRC S&D
Alexander.A.Teverovsky@nasa.gov

List of Acronyms and Symbols

AC	alternating current	MSL	moisture sensitivity level
C	capacitance	PI	polyimide
CCS	constant current stress	RH	relative humidity
CTE	coefficient of thermal expansion	S&Q	screening and qualification
DCL	direct current leakage	SBDS	simulated breakdown screen
DF	dissipation factor	SCT	surge current test
EDS	energy dispersive analysis	SEM	scanning electron microscopy
EM	electrical measurements	STD	standard deviation
ESR	equivalent series resistance	T	temperature
HV	high voltage	TSD	terminal solder dip
IR	infra red	VBR	breakdown voltage
LDC	lot date code	VR	rated voltage
MC	molding compound	X-sect	cross-section

Abstract

Soldering of molded case tantalum capacitors can result in damage to Ta₂O₅ dielectric and first turn-on failures due to thermo-mechanical stresses caused by CTE mismatch between materials used in the capacitors. It is also known that presence of moisture might cause damage to plastic cases due to the pop-corning effect. However, there are only scarce literature data on the effect of moisture content on the probability of post-soldering electrical failures. In this work, that is based on a case history, different groups of similar types of CWR tantalum capacitors from two lots were prepared for soldering by bake, moisture saturation, and long-term storage at room conditions. Results of the testing showed that both factors: initial quality of the lot, and preconditioning affect the probability of failures. Baking before soldering was shown to be effective to prevent failures even in lots susceptible to pop-corning damage. Mechanism of failures is discussed and recommendations for pre-soldering bake are suggested based on analysis of moisture characteristics of materials used in the capacitors' design.

Outline

- Background.
 - History case.
 - Literature data.
- Test plan.
- Test results.
 - Initial characterization of the lots.
 - Effect of preconditioning on AC and DC characteristics.
 - Solder reflow profile.
 - Effect of preconditioning on post-soldering characteristics and failures.
 - Effect of the terminal solder dip testing.
- Discussions.
 - Moisture in solid chip tantalum capacitors.
 - Mechanism of failures.
- Summary and recommendations.

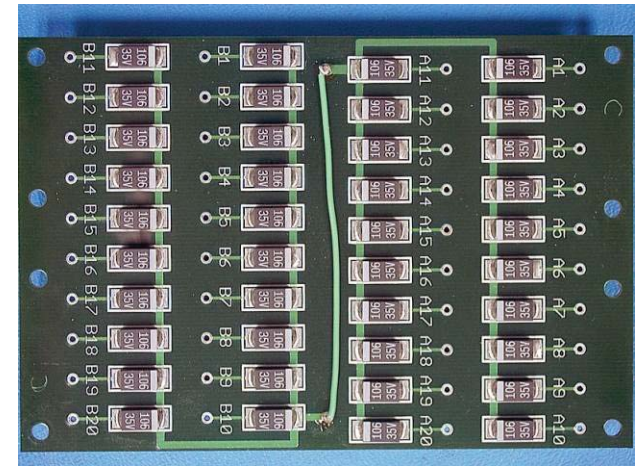

Background



- ❑ Both, an engineering and a flight units failed within a few seconds after powering on for the first time.
- ❑ The failure was due to CWR29 10uF 35V capacitors used in the 15V power line. Maximum current in the line was limited to 1 A.
- ❑ After capacitors were replaced, the unit operated normally.
- ❑ Out of 20 LDC1307 capacitors from Mfr.A used in the unit, 10 failed catastrophically.
- ❑ Out of 18 similar capacitors from Mfr.B that were also used in this unit, none failed short circuit.
- ❑ Analysis of leakage currents after desoldering showed that a large proportion of capacitors from both lots had substantially degraded characteristics (70% from Mfr.A and 40% from Mfr.B).
- ❑ Out of two capacitors from Mfr.A that were also used on the board, but inactivated during the first power on, one sample failed short circuit at $R \sim 6.8 \text{ k}\Omega$.
- ❑ Reflow soldering temperature profile was close to the one recommended for tantalum capacitors by manufacturers.

Background, Cont'd

- ❑ A review of production test documents did not reveal any anomaly with LDC1307.
- ❑ A review of the system design and test condition ruled out the possibility of voltage overshooting of the parts during turn-on of the unit.
- ❑ Visual and X-ray analysis of failed capacitors did not show any defects.
- ❑ Stripping of molding compound by Mfr.A and GSFC lab showed that all capacitors with LDC1307 had damage at the anode shoulder. IR images of 6 failed capacitors confirmed that the location of damage is at the anode shoulder.
- ❑ This, as well as comparison with the other lot used in the unit, lead to a suspicion that the problem is lot-related.
- ❑ Another possibility that is usually considered when first turn-on failures happen, is that the capacitors were damaged during soldering.
- ❑ LDC1307 was marked MSL 1, which means unlimited floor life and no need for bake before soldering.

The purpose of this study is to evaluate the effect of preconditioning and lot-t-lot variations on the probability of post-soldering failures.

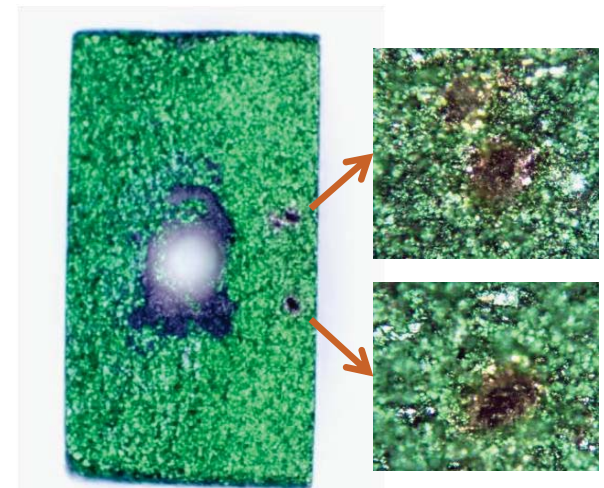

Top view (anode shoulder) of a stripped capacitor showing damaged sites

Literature Data: Effect of Soldering

- ❑ It is well known that molded case tantalum capacitors can be damaged during soldering and related to damaging first power-on failures are one of the major reasons for voltage derating [1].
- ❑ The effect is mostly attributed to CTE mismatch between molding compound and tantalum slug [1, 2] and was directly demonstrated in [3].
- ❑ Tantalum chip capacitors are the only parts that require 100% reflow simulation to reduce soldering-related failures. Per MIL-PRF-55365 reflow conditioning requires one exposure to 230 °C for 5 sec.
- ❑ Different lots might have different susceptibility to soldering-related failures [4] and large-size capacitors are assumed to have a higher risk of being damaged [5].
- ❑ Mechanical stresses associated with reflow soldering can reduce breakdown voltage and increase the probability of failures in humid environments [6].
- ❑ Manual soldering might be especially detrimental: stresses caused by touching a part with a soldering iron can cause more damage than temperature gradients [7].
- ❑ A terminal solder dip test was recommended to assess the robustness of tantalum capacitors to manual soldering [8].

Literature Data: Pop-Corning

- ❑ Direct measurements of deformation of plastic packages during soldering simulation showed the presence of pop-corning in tantalum capacitors. Baking before soldering was recommended to eliminate possible problems [4]. Degradation of VBR after thermal cycling was observed in 4 out of 6 MIL and 2 out of 10 commercial lots
- ❑ Pop-corning-related failures of chip tantalum capacitors were reported by R. Dobson from Raytheon [9]. The failure mechanism was attributed to silver migration that happen in humid environments prior to soldering.
- ❑ Occasionally, cracks in the packages are observed on parts before soldering [10].
- ❑ An unusual failure in BGA components that are adjacent to chip tantalum capacitors was reported in [11]. The failures were attributed to moisture that penetrated and was trapped in capacitors. During the board assembly reflow process the moisture heated up, built up the pressure resulting in cracking of the case. Moisture from the caps was out-gassing through the cracks, blowing the solder, and causing shorts or opens between BGA balls.

Deformation of Tantalum Capacitors During Reflow Soldering Simulation [4]

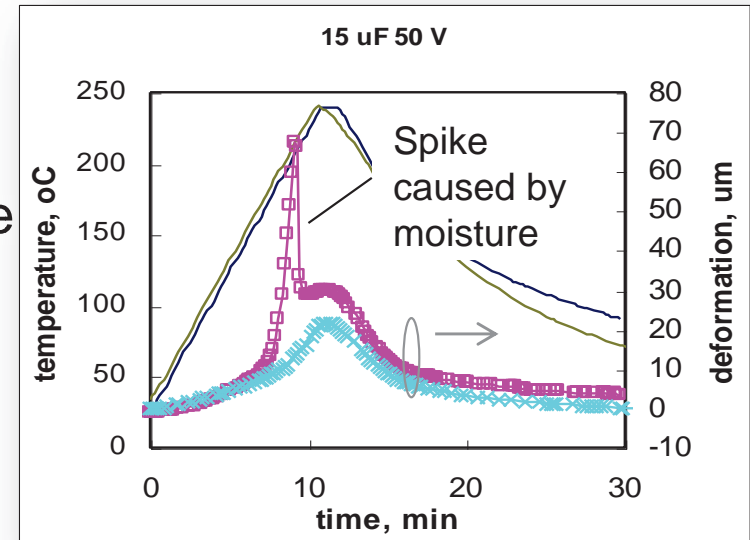

Literature Data: Effect of Preconditioning

- ❑ In a recent study by W. Winkel and E. Rich [12] from Raytheon, the impact that moisture and exposure to solder reflow have upon 35V CWR11 capacitors was studied. 850 capacitors were tested by different profiles varying by bake-out, humidity, and aqueous cleaning. Results of the testing showed:
 - No failures for parts soldered after bake-out at 40°C for 72 hours.
 - Simulation of the uncontrolled storage profile (preconditioning at 48 hr, 30°C/91%RH) before soldering and repeat soldering after aqueous wash showed that all parts remained within the specification limits. All parts had breakdown voltages exceeding VR; however, ~2% of capacitors in each group had reduced breakdown voltages compared to the initial distributions measured by SBDS.
 - Exposure to 3 cycles of soldering also reduced VBR measured by SBDS in ~5% of parts.
 - The study indicates that the presence of moisture might increase the probability of post-soldering failures.
- ❑ The pop-corning can be initiated by liquid cleaning of PWBs. Warm parts might suck liquid in through gaps in the package. The liquid will be trapped in the case after cooling and cause its rupture when another side of the board is soldered. Application of a moisture barrier between anode and silver ink reduced substantially the probability of pop-corning failures especially in high-humidity countries that was explained by decreasing silver migration to the dielectric [13].

MSL: Manufacturers' Approach

- ❑ According to the product catalogs, most MIL-spec tantalum capacitors have MSL 1, which means unlimited floor life at $T \leq 30\text{ }^{\circ}\text{C}$ and $\text{RH} \leq 85\%$. However, there is no established procedure for testing after soldering, and it is not clear how the level of MSL was verified.
 - Vishay: The molded series devices meet MSL 1, are not considered moisture sensitive and are not stored or shipped in moisture protective packaging.
www.vishay.com/doc?40135 Some commercial molded case and coated devices are considered MSL 2a or 3 <http://www.vishay.com/docs/40110/faq.pdf>
 - KEMET: all MIL parts have MSL 1. For commercial product, the necessity of moisture bags should be indicated in the ordering information.
http://www.kemet.com/Lists/ProductCatalog/Attachments/226/KEM_TC105_CWR.pdf
 - AVX Biddeford has begun shipping all COTS+, military, space level, and medical grade surface mount tantalum capacitors in moisture resistant bags as part of an upgrade to best practice. Biddeford product that is considered to be MSL 3 includes TBMs, TCPs, TBJ V, U and E case, and TAZ V and X case sizes. The remainder of tantalum capacitors are rated MSL 1 (per J STD 020D). <http://www.avx.com/docs/masterpubs/highreלטant.pdf>
- ❑ Per JESD22-A113 “Preconditioning of Nonhermetic Surface Mount Devices Prior to Reliability Testing”, verification of MSL 1 requires soaking at $85\text{ }^{\circ}\text{C}$, 85% RH for 168 hours. However, a detailed plan for the initial and post-reflow testing should be developed for each device based on its specifics.

✓ MSL testing for tantalum capacitors is not specified.

Part Types and Preliminary Evaluation

- ❑ Parts.
 - 80 samples of CWR29 10uF 35V, LDC1307 (failed on MCE board).
 - 80 samples of CWR09 10uF 35V, LDC1338 (reference parts from the same manufacturer).
- ❑ Preconditioning.
 - Gr.I - without preconditioning (use “as is”) for manual soldering simulation;
 - Gr.II - without preconditioning, “as is”, for reflow soldering;
 - Gr.III - soldered after moisture soak with Gr.IV and bake at 125 °C for 15 hr;
 - Gr.IV - soldered after moisture soak at 85 °C, 85%, RH, 100hr.
- ❑ Both lots were soldered onto PI PWBs at the same process, went together through the same preconditioning and tests.
- ❑ All parts passed incoming visual inspection and electrical measurements.
- ❑ Gross leak testing without pressurization was performed on 40 CWR29 capacitors. One sample appeared to have a few small bubbles emitting from the corner.

Test Flow

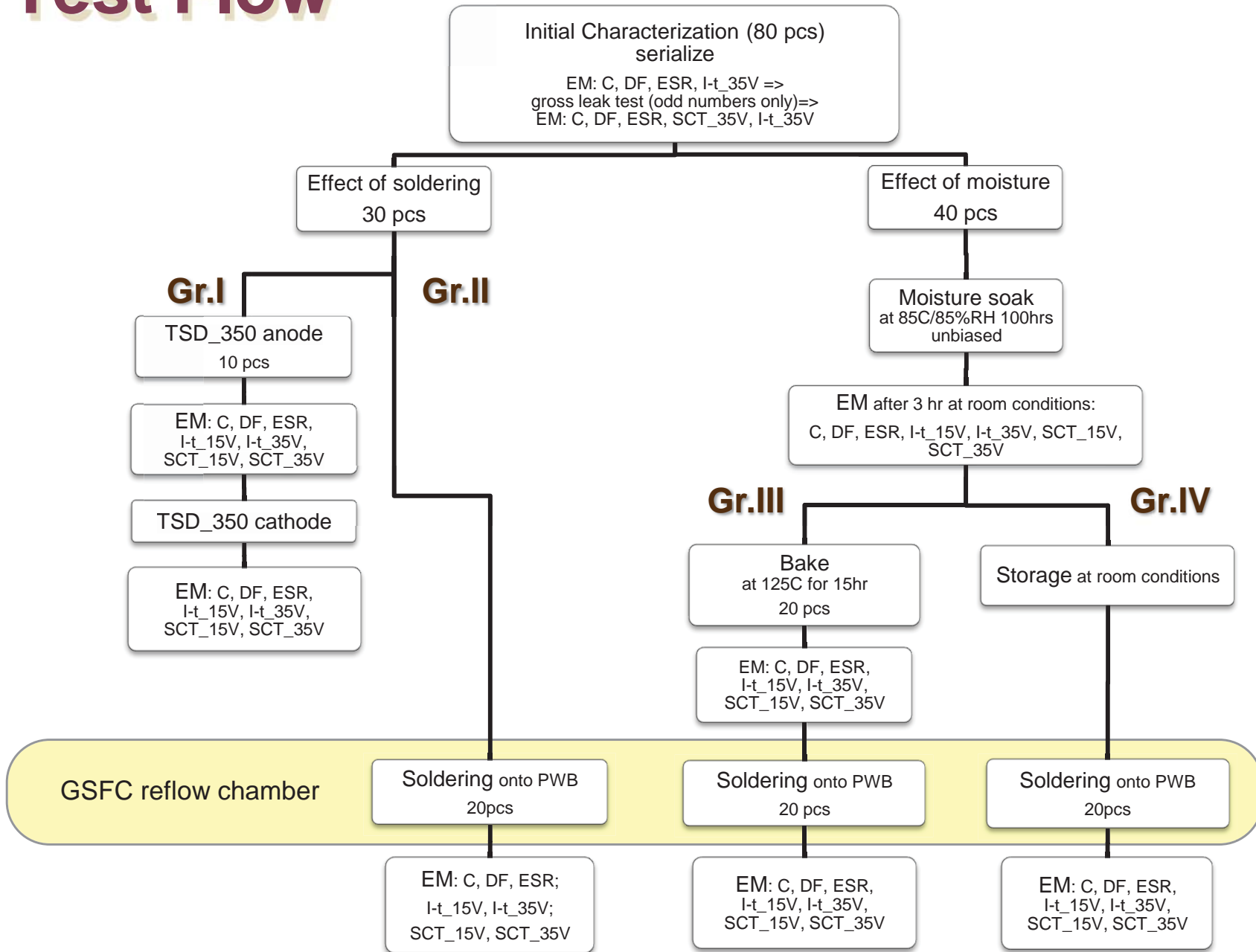

Initial AC Characteristics

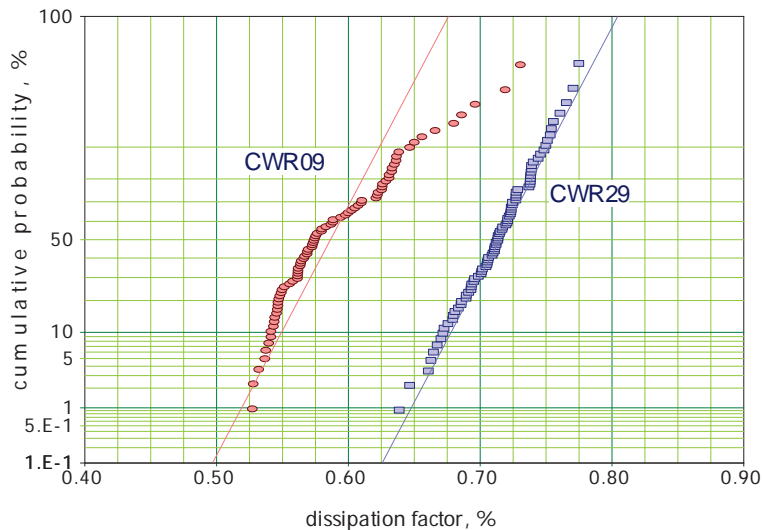
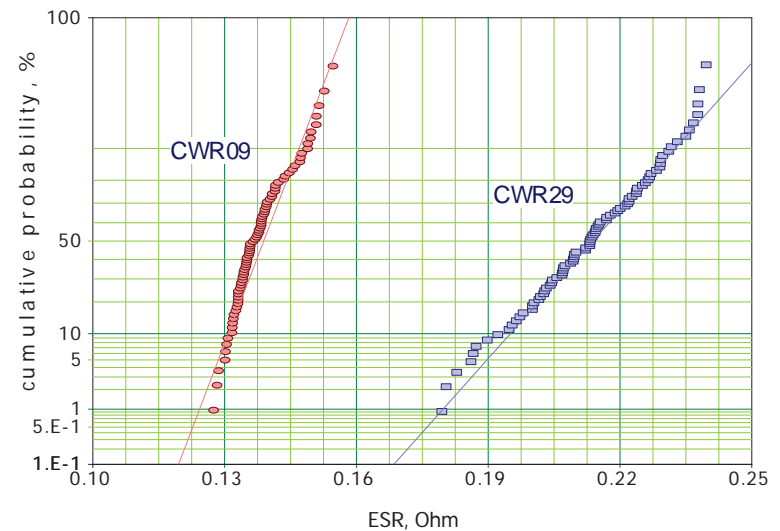
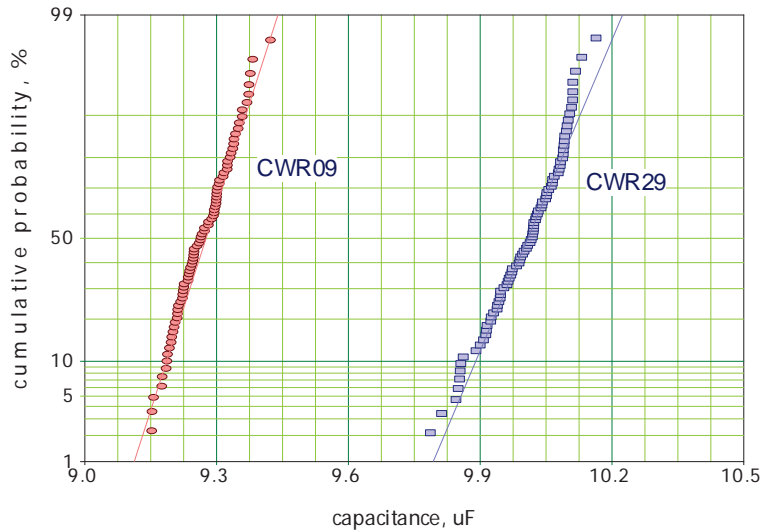

- ✓ All characteristics are well within the specification limits ($DF_{max} = 8\%$, $ESR_{max} = 0.5 \text{ Ohm}$).
- ✓ DF values are ~ 10 times less than the specified limit.
- ✓ Although CWR29 suppose to be a low-ESR version of CWR09, ESR values in CWR09 capacitors are ~ 50% less than in CWR29.

Surge Current Testing

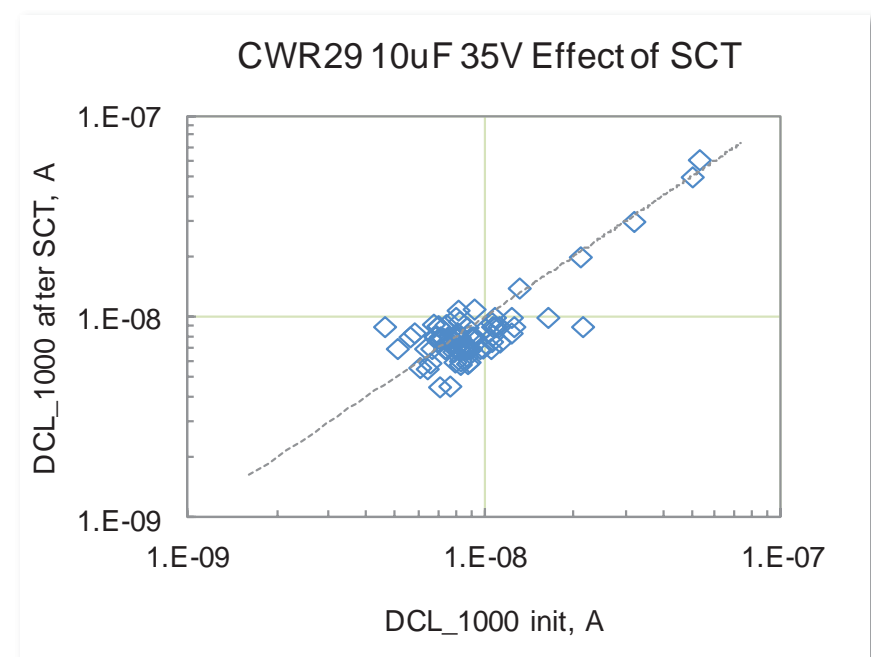
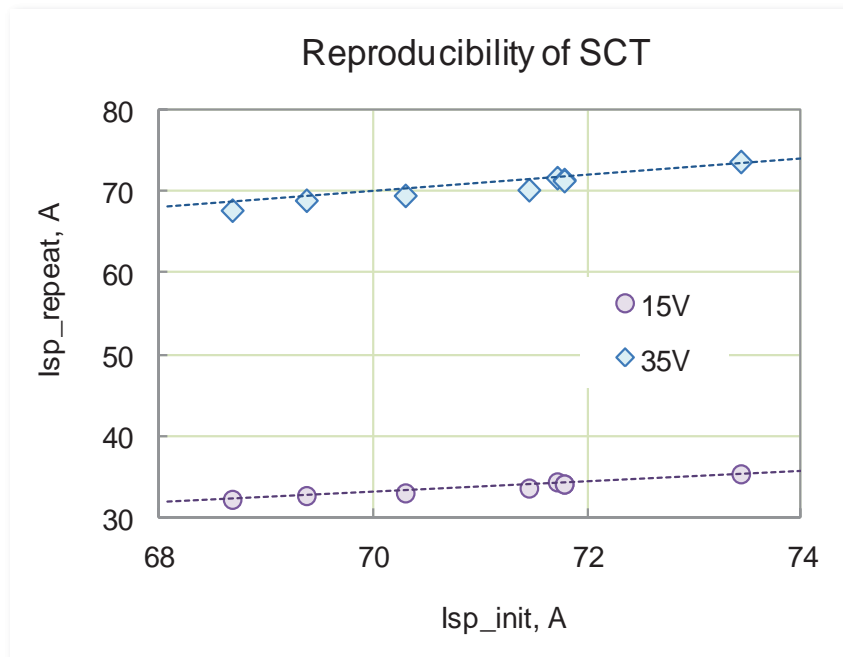

- ✓ The set-up used resulted in surge currents at a minimal additional impedance ($R_{eff} \sim 0.2$ Ohm), which created current spikes that are within the M55365 requirements, but more severe compared to the testing during manufacturing.
- ✓ To better simulate application conditions, the parts were first tested by 3 cycles at 15V and then by three cycles at 35V.
- ✓ The set-up allowed for verifiable and reproducible test conditions.
- ✓ To confirm that SCT does not damage parts, leakage currents in capacitors were measured before and after SCT.

Initial Surge Current Testing

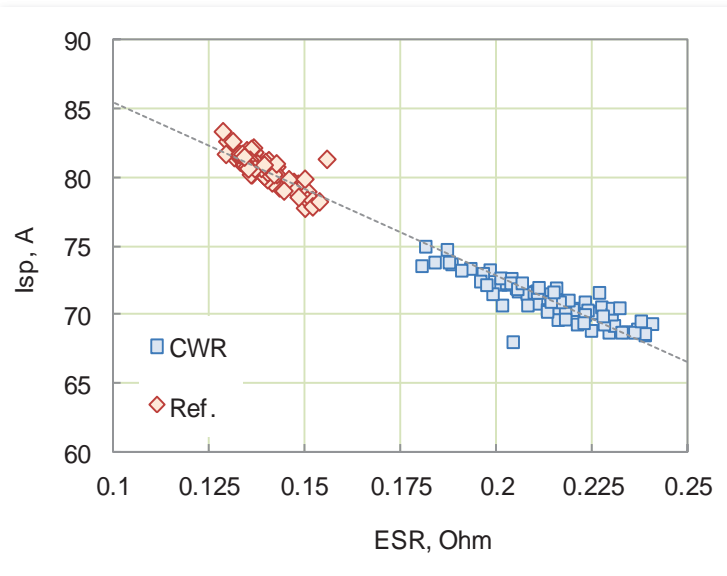
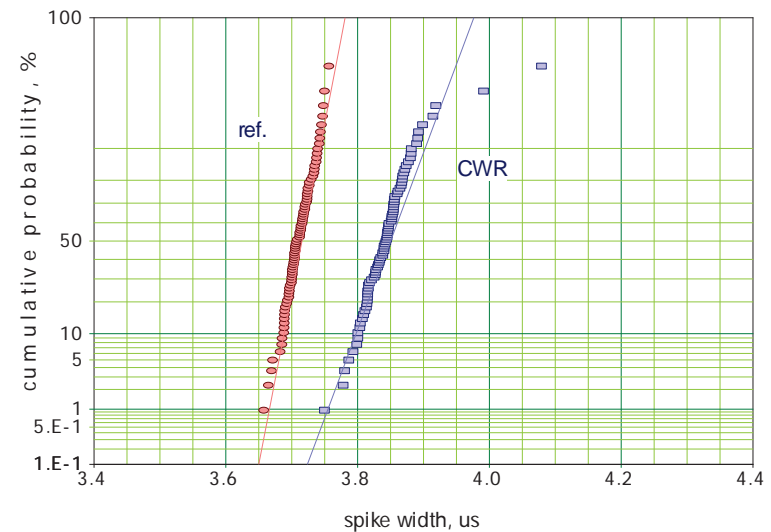
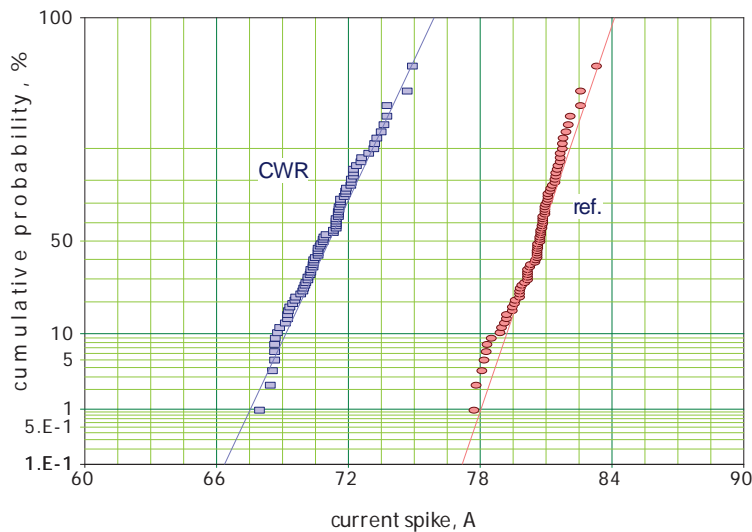

- ✓ All 160 parts passed SCT at 35V that resulted in current spikes ~ 75 A.
- ✓ A good correlation between I_{sp} and ESR indicates low circuit resistance, $R_{eff} \sim 0.29 \Omega$.
- ✓ The difference in I_{sp} for CWR29 and the reference lots corresponds to ESR values.
- ✓ Difference in the pulse widths corresponds to the characteristic time of the short circuit discharge: $\tau \approx C \times ESR$.

Breakdown Voltages in Capacitors Desoldered from MCE Boards

- ❑ Mf.A capacitors were removed from the failed engineering board (LDC1215) and both, Mfr.A (LDC1307) and Mfr.C capacitors were removed from the flight board.
- ❑ Breakdown voltages for these parts as well as for LDC1307 and reference capacitors were compared to average values for different types of 35V capacitors.

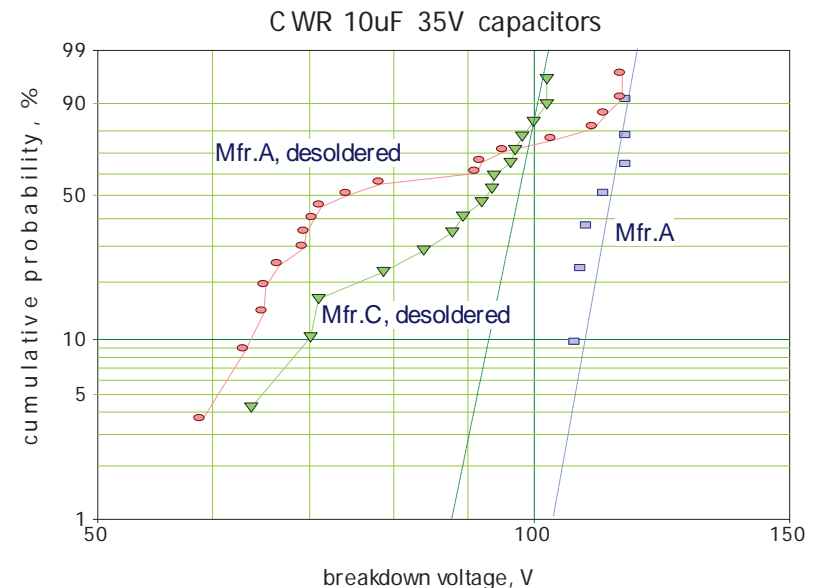
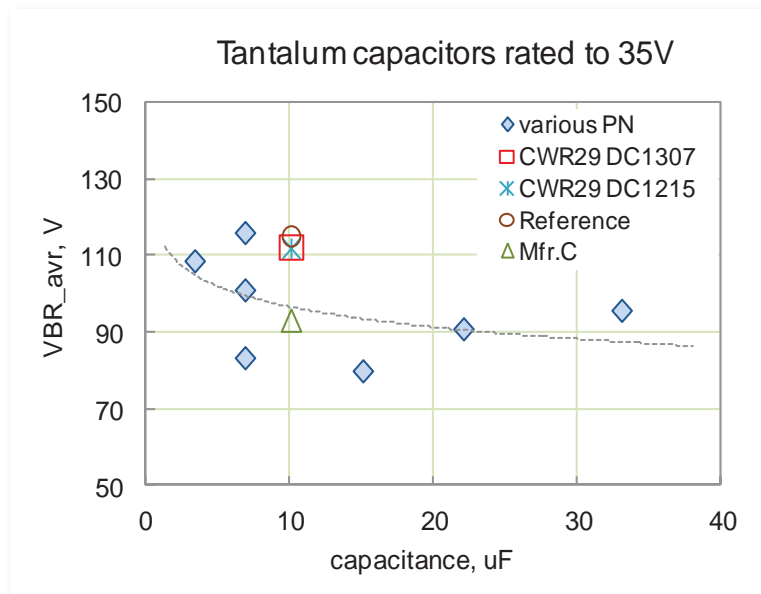

- ✓ Intrinsic breakdown voltages in 10uF capacitors from Mfr.A exceed $3 \times VR$ and are above average values typical for capacitors rated to 35V.
- ✓ All types of capacitors removed from the units had low-voltage tails of VBR distributions indicating presence of large proportion of defects in the dielectric.

Initial DCL Characteristics

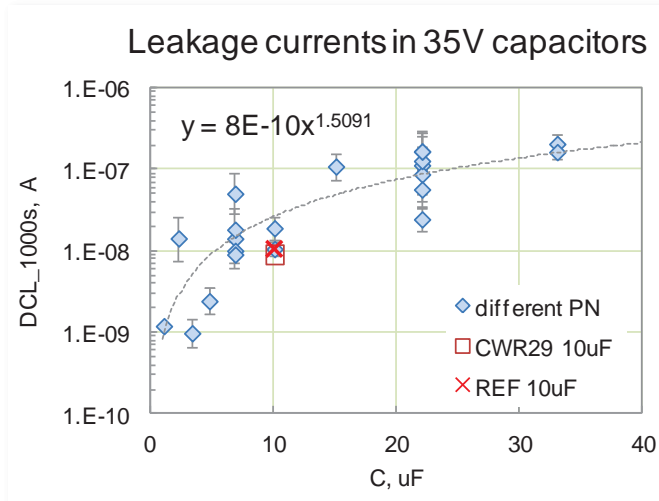
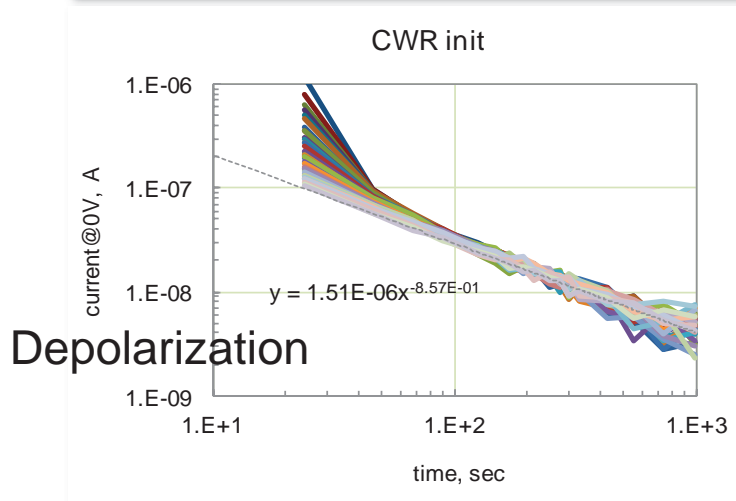
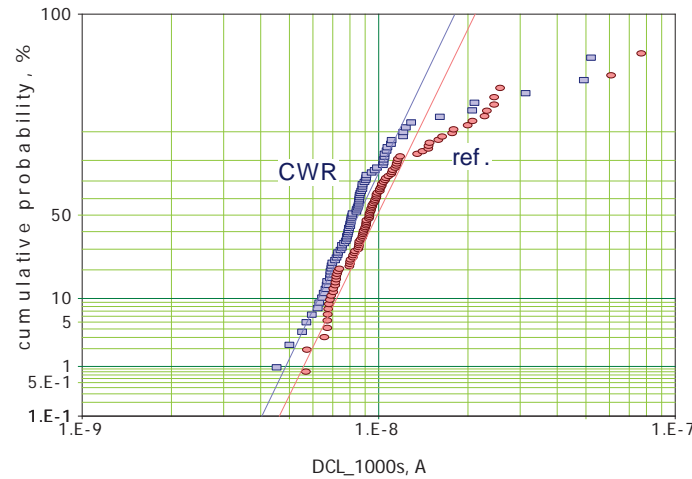
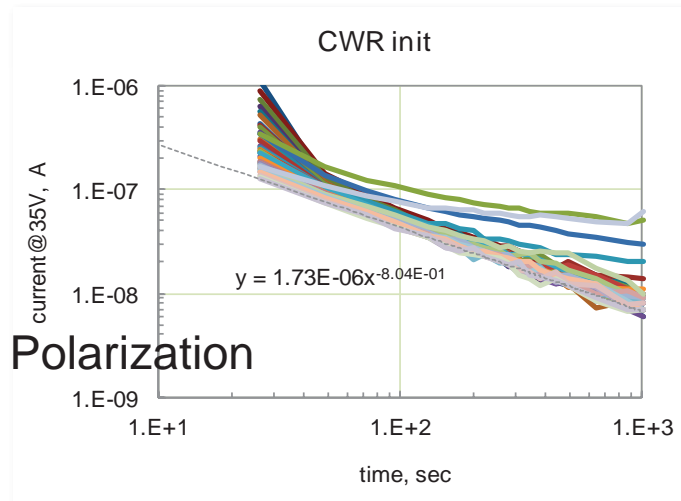

Analysis of initial characteristics showed that both lots had tight distributions of AC and DC characteristics indicative to high-quality products. No anomalies were observed during surge current testing, which rules out the possibility of screening escapees.

- ✓ DCL was measured after 1000 sec to increase the sensitivity to defects.
- ✓ Majority of parts (~80%) had leakage currents caused by absorption.
- ✓ All parts were well (more than 100X) within the specification, $DCL_{max} = 4 \mu A$.
- ✓ Both lots had similar DCL that were below median values for 35V capacitors.

Effect of Preconditioning and Soldering on AC Characteristics of Gr.III Capacitors

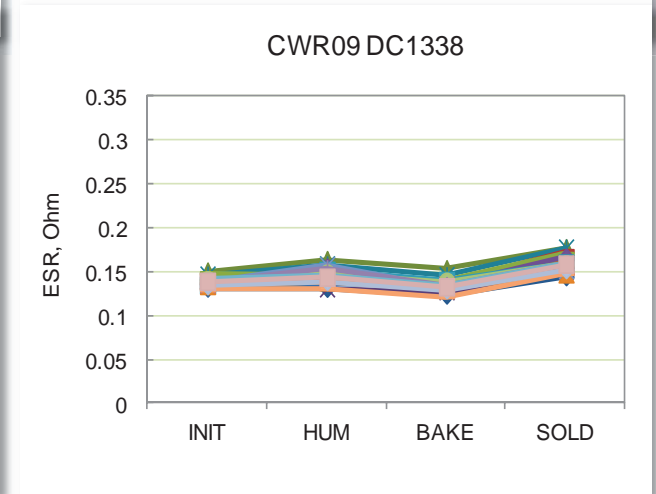
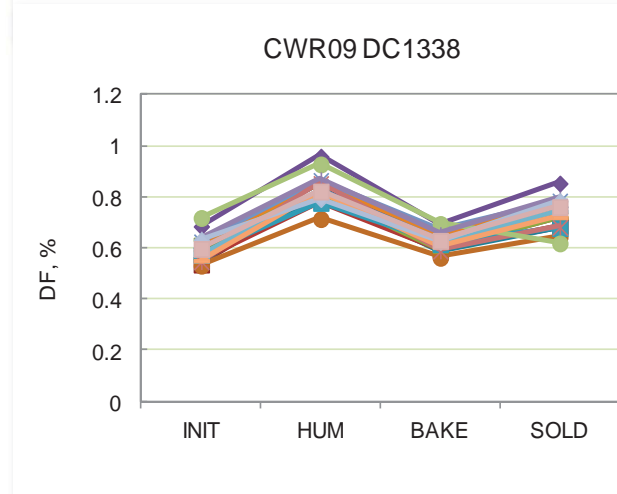
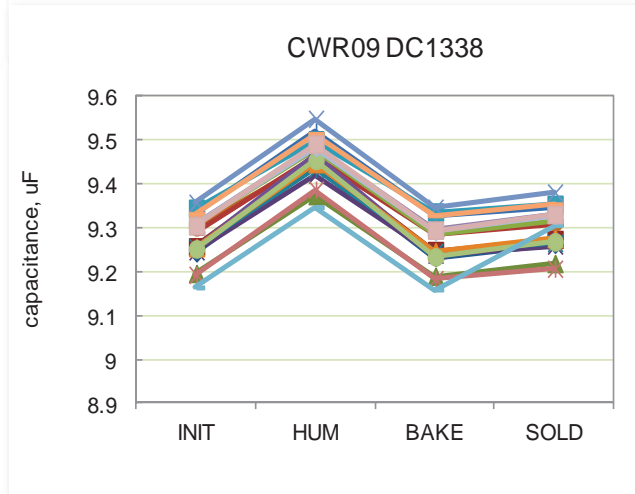
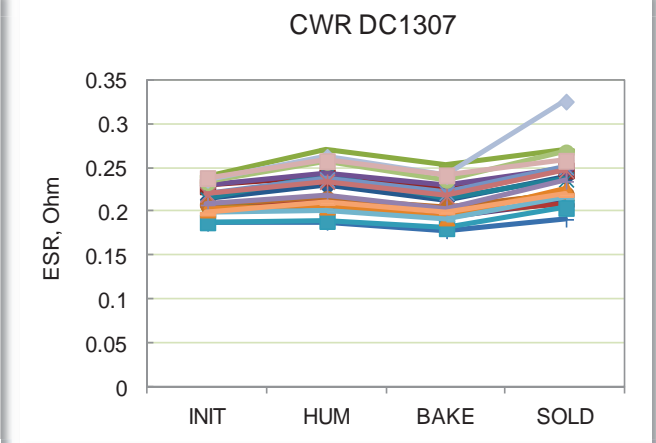
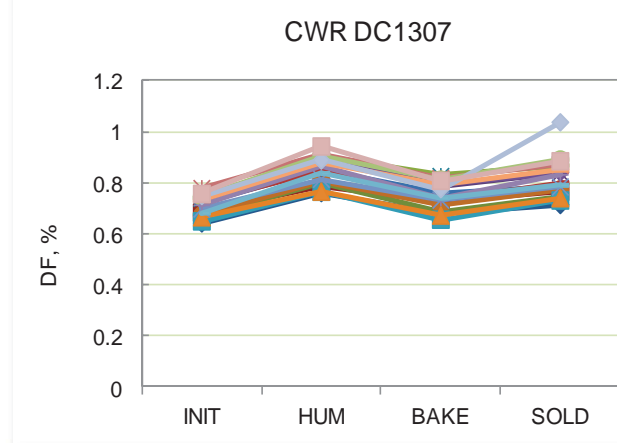
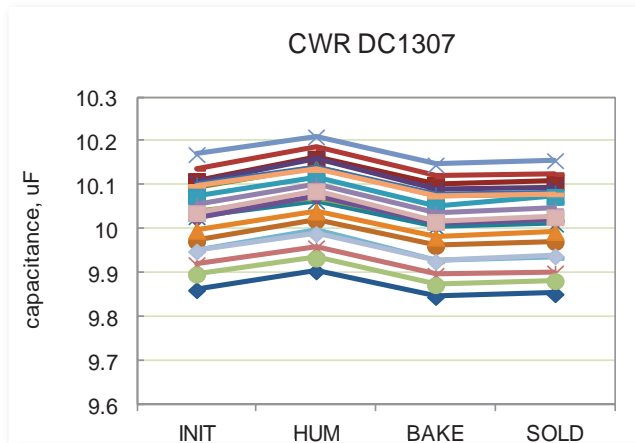

- ❑ All 160 capacitors passed electrical measurements for C, DF, and ESR.
- ❑ No substantial variations through preconditioning and soldering (ESR raise ~16%).
- ❑ An increase of capacitance after moisture soak (0.41% for CWR29 and 2.1% for Ref.) is consistent with literature data [12] and indicates good coverage during MnO₂ impregnation.

Effect of Preconditioning on DCL and Moisture Uptake

CWR29 DC 1307 effect of preconditioning

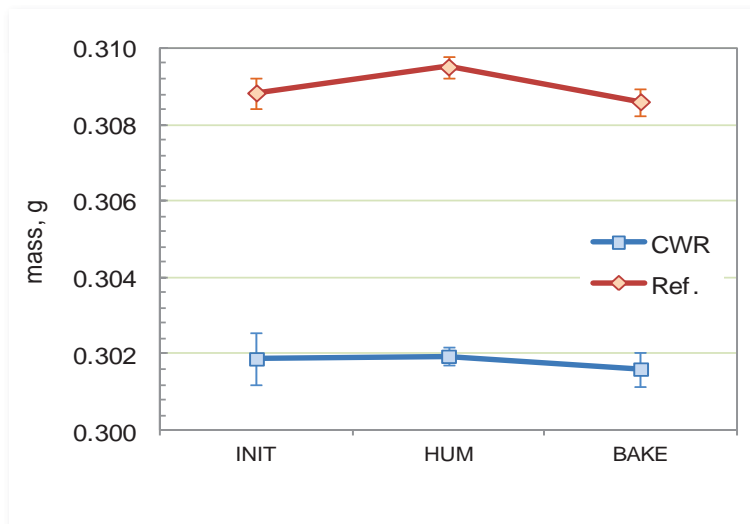
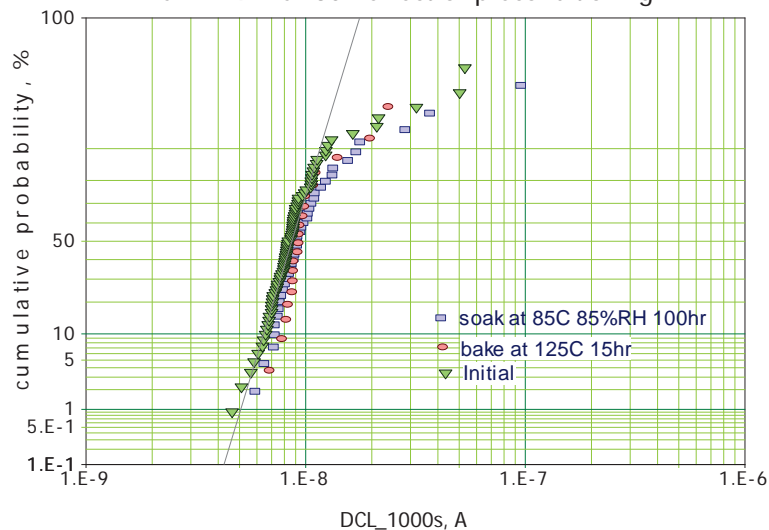

Effect of preconditioning on average mass of the parts (error bars = STD).

Ref. DC 1338 effect of preconditioning

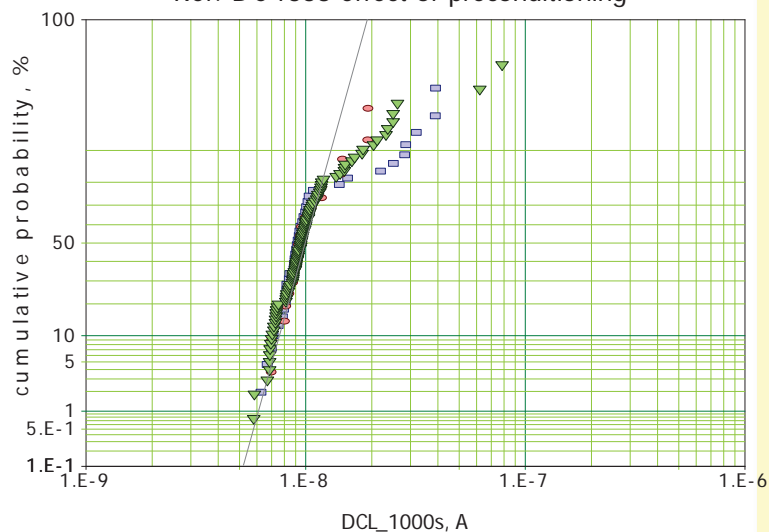

- ✓ Moisture soak and bake did not affect DCL.
- ✓ Moisture uptake after soak was ~0.067mg for CWR29 and 0.68mg for ref. parts indicating that CWR29 capacitors were close to saturation.
- ✓ Baking resulted in mass loss of 0.27mg for CWR29 and 0.23mg for CWR09 (ref.) capacitors suggesting similar moisture content in “as is” condition.
- ✓ Moisture uptake in humidity chamber was greater in ref. parts (0.91 mg vs. 0.33 mg for CWR29). This might indicate a larger volume of micropores in ref. parts.

Effect of Preconditioning on SCT

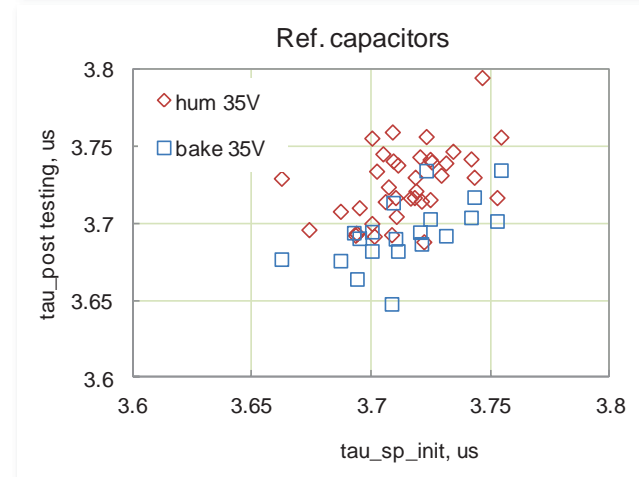
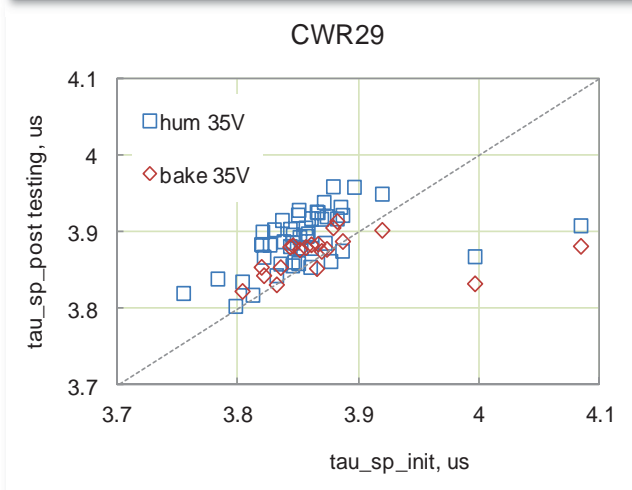
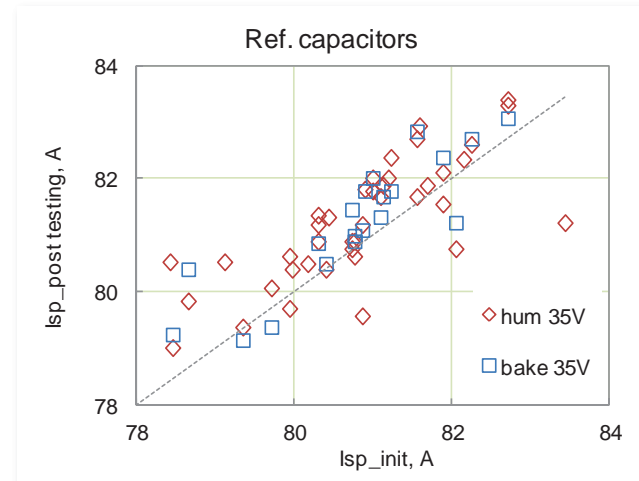
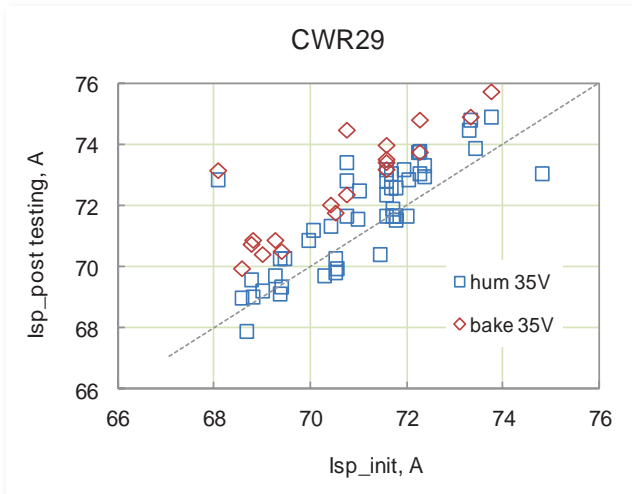

- ✓ SCT was repeated after moisture soak and then after bake.
- ✓ All parts passed the testing and no significant effect on the amplitude and width of the current spikes was observed.
- ✓ Some increase in I_{sp} after bake for CWR29 corresponds to ESR variations.

Reflow Soldering

- ❑ Temperature profile was selected to comply with manufacturer's recommendations (AVX: max rate 2 °C/sec, $T_{\max} = 225^{\circ}\text{C}$; KEMET: 3 °C/sec, $T_{\max} = 235^{\circ}\text{C}$) and mimic soldering conditions for flight boards.
- ❑ The chamber is a 10-zone convection reflow oven (Vitronics XPM3). No N_2 purging was not used. Solder paste: Nordson, Sn63/Pb37, RMA-P200.
- ❑ After placing parts on boards with solder, they were “de-moisturized” for two hours at 93°C before reflow.
- ❑ No cleaning or touch-up to improve fillets after soldering was used.
- ❑ To simulate worst case conditions, each board passed through 3 reflow cycles.
- ❑ Parts were soldered in 2 days after bake and in 4 days after moisture soak.
- ❑ Optical examinations of soldered capacitors showed no defects.

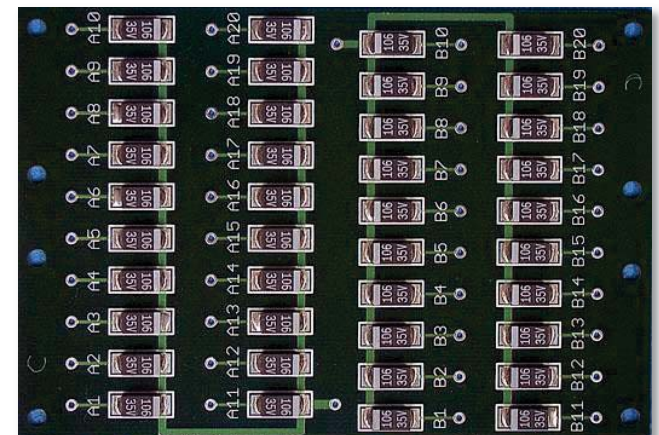
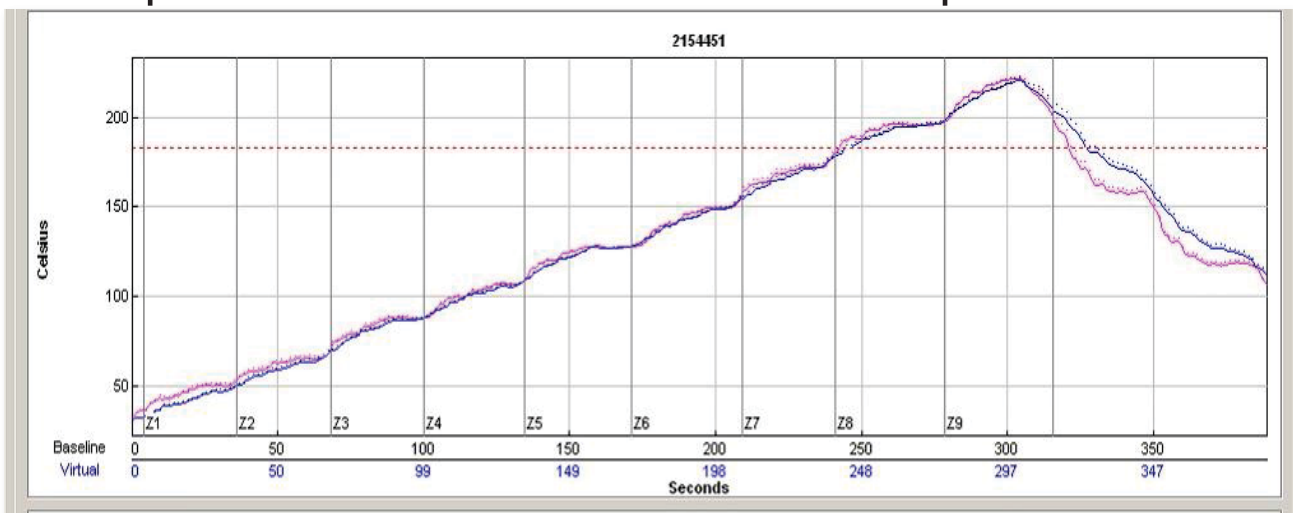

Effect of Reflow Soldering on AC Characteristics

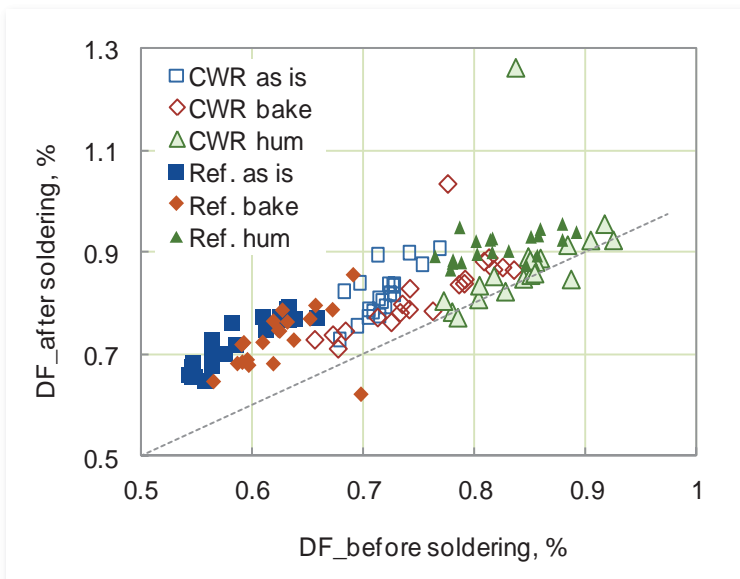
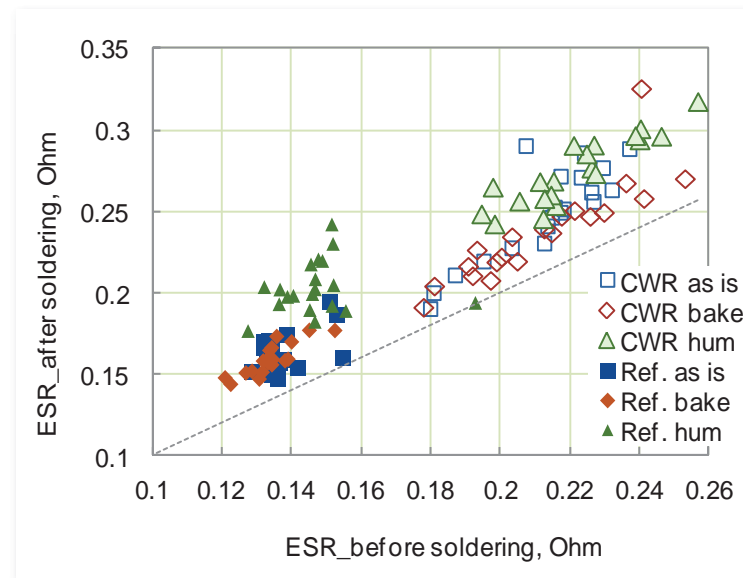
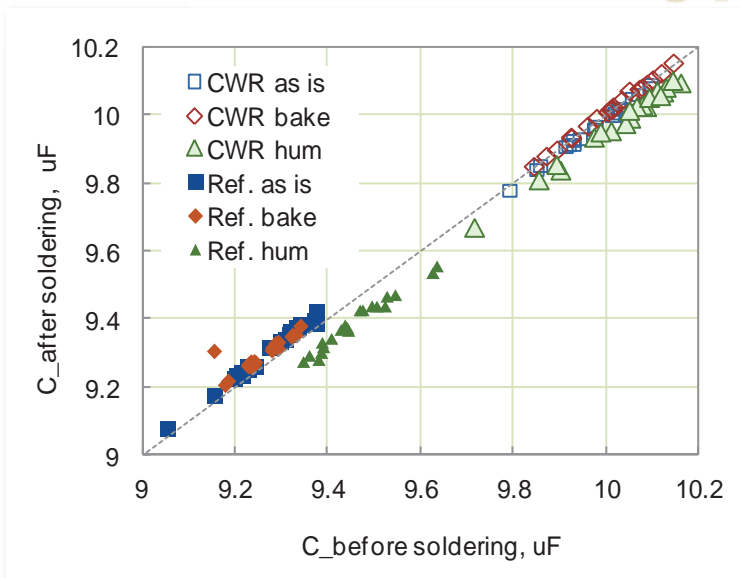

- ✓ All post-soldering AC characteristics were within the specification limits.
- ✓ Minimal changes occur for parts after baking.
- ✓ Parts soaked in moisture had decreased C.
- ✓ ESR increases as a result of soldering for all types of preconditioning; however, degradation was greater in capacitors after moisture soak.

Effect of Reflow Soldering on AC Characteristics, Cont'd

Changes in AC characteristics as a result of soldering compared to the initial values measured on loose parts

characteristic	as is	hum	bake
ΔC_{CWR29} , %	-0.11 (0.1)	-0.07 (0.12)	-0.12 (0.06)
ΔDF_{CWR29} , %	14.8 (4.9)	23.4 (13.3)	15.2 (6.17)
ΔESR_{CWR29} , %	16.8 (7.68)	28.7 (6.03)	10.8 (7.17)
ΔC_{ref} , %	0.28 (0.57)	1.15 (0.17)	0.26 (0.31)
ΔDF_{ref} , %	22.9 (3.65)	54.1 (8.66)	22.9 (9.6)
ΔESR_{ref} , %	18.3 (7.5)	46.3 (8.2)	15.7 (4.5)

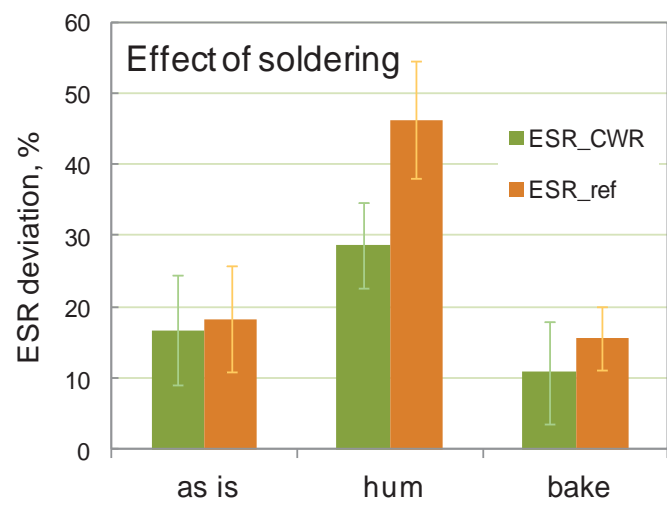
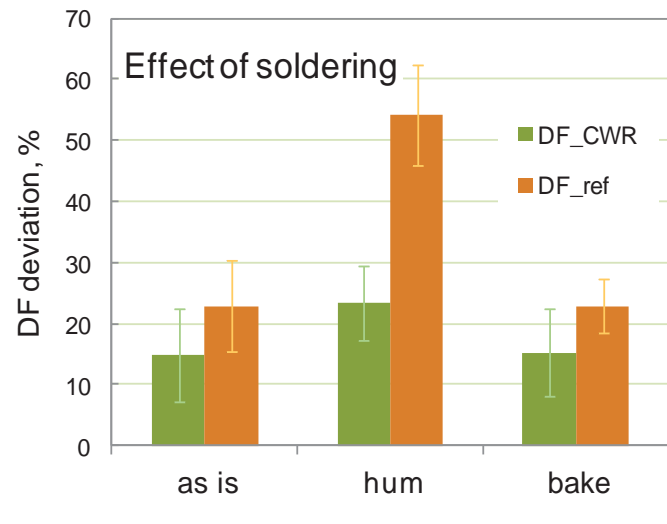

- ✓ No substantial changes in capacitance.
- ✓ Degradation of DF and ESR is greater for reference parts for all types of preconditioning.
- ✓ Parts after baking increase ESR on 10% to 16%, but in the presence of moisture the increase is 29% to 46%.

Failures after Reflow Soldering

- ❑ After soldering the parts were tested in the sequence shown in the table.
- ❑ Out of 11 CWR29 parts that failed at 15V (>1A after 50 μsec), one failed the first SCT cycle, 8 after the second, and 2 after the third cycle. All nine parts tested at 35V failed at the first cycle.
- ❑ One CWR29 part in “as is” condition failed after 1 hour of DCL testing at 35V.
- ❑ Some SCT failures resulted in mechanical damage to the parts; however, no burning was observed.

Precond./ Test	CWR29, DC1307			CWR09 (Ref.) DC1338		
	as is	Bake	Moisture	as is	Bake	Moisture
AC testing	0/20	0/20	0/20	0/20	0/20	0/20
SCT at 15V	2/20	0/20	9/20	0/20	0/20	0/20
SCT at 35V	1/18	0/20	8/11	0/20	0/20	1/20
DCL at 15V	0/17	0/20	0/3	0/20	0/20	0/19
DCL at 35V	1/17	0/20	0/3	0/20	0/20	0/19
Total	20%	0	85%	0	0	5%

✓ The probability of post-soldering failures depends on both factors: preconditioning and lot date code.

SCT Failures After Reflow Soldering

- ❑ Board B was populated with CWR29 capacitors that were preconditioned in humidity chamber (samples A1-A20) and reference parts (samples B1-B20).
- ❑ Cracks were observed on the top and at the bottom of the CWR29 capacitors.

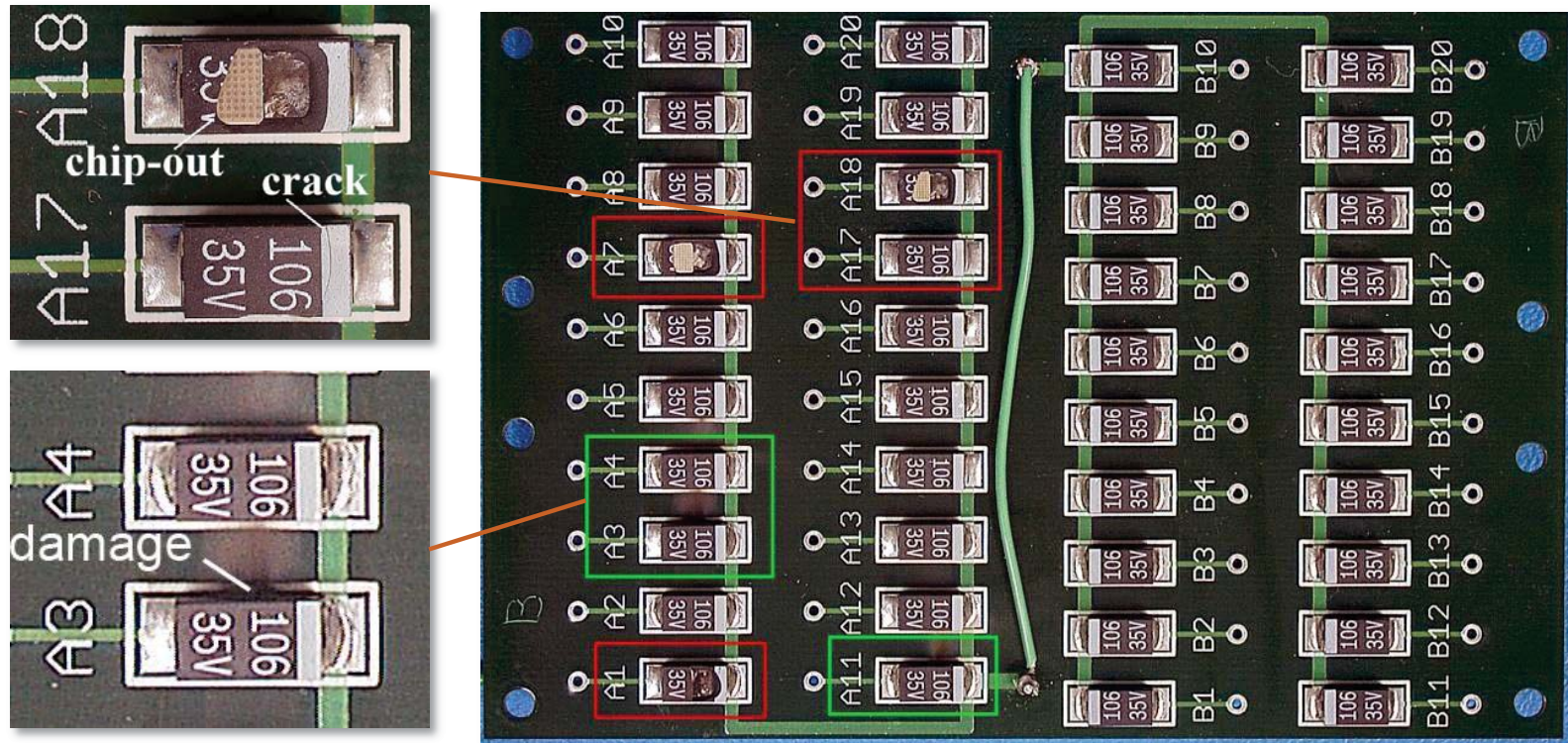

- ✓ No case defects were observed after soldering.
- ✓ Case cracking and damage occur in 50% of CWR29 capacitors after SCT.
- ✓ SCT did not cause damage to CWR09 (reference) parts.

Effect of Reflow Soldering on DCL

Effect of soldering, CWR29

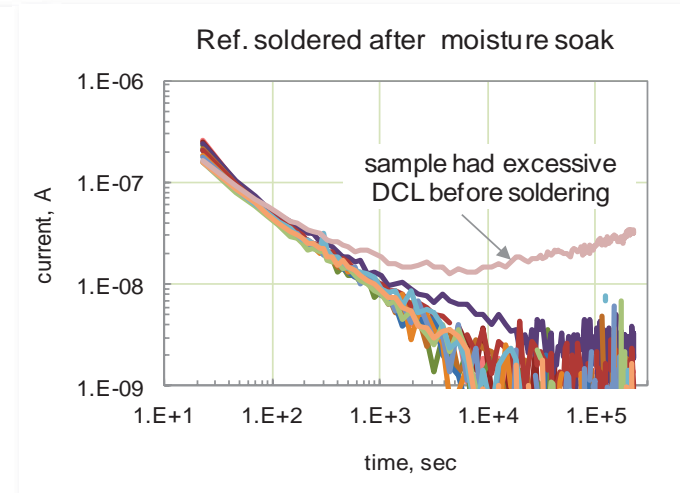
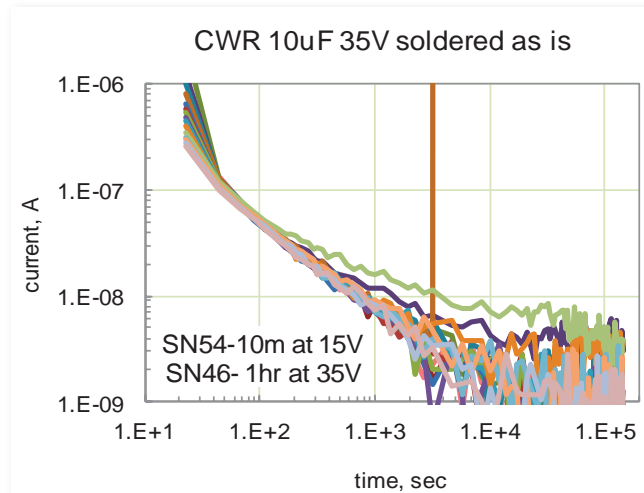
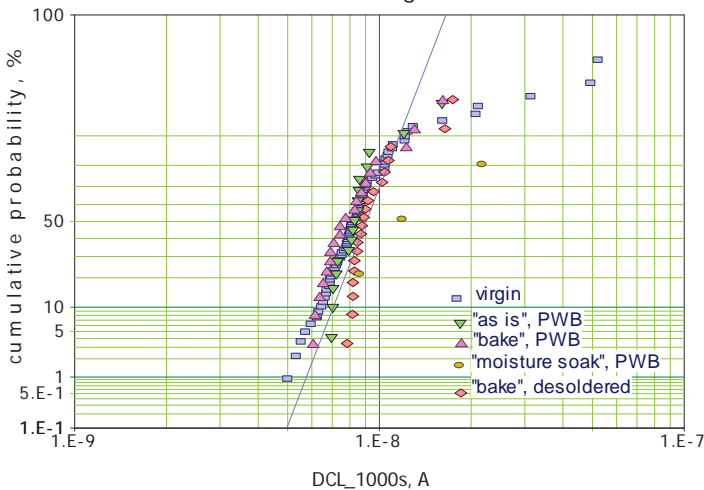

Effect of soldering, ref. capacitors

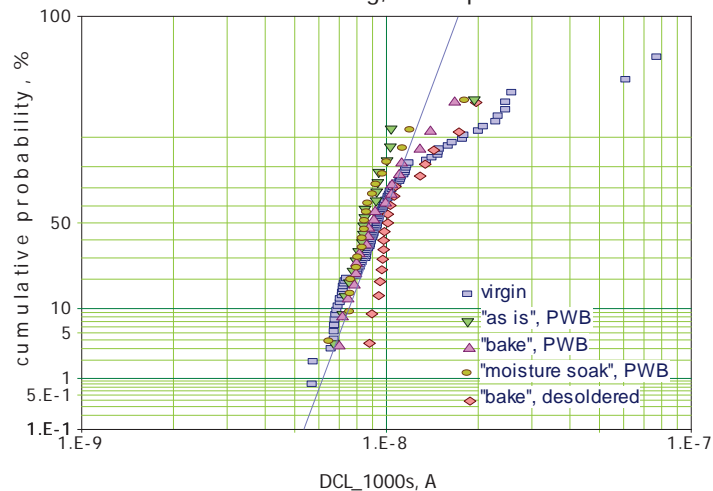

- ✓ One CWR29 sample from Gr.II (“as is”) failed after 10 min at 15V and another after 1 hr at 35V.
- ✓ No difference in distributions of leakage current for not-failed capacitors with different preconditioning.
- ✓ Non-failed CWR29 samples from the group that was soaked in moisture before soldering had low leakage currents.
- ✓ Desoldering of baked capacitors did not change DCL distributions.

Effect of Reflow Soldering on SCT

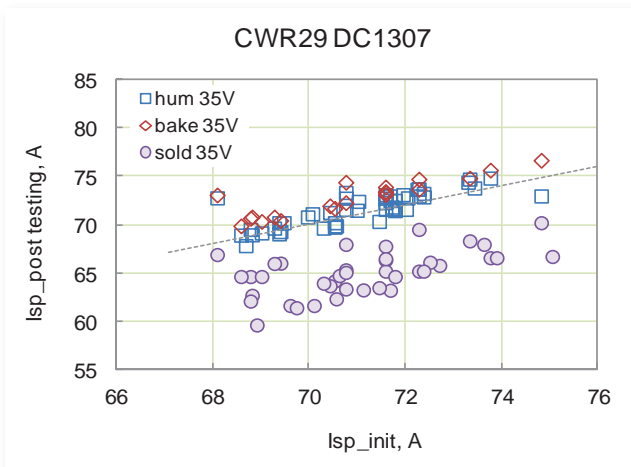

Correlation between current spike amplitudes measured initially, after different preconditioning, and after soldering

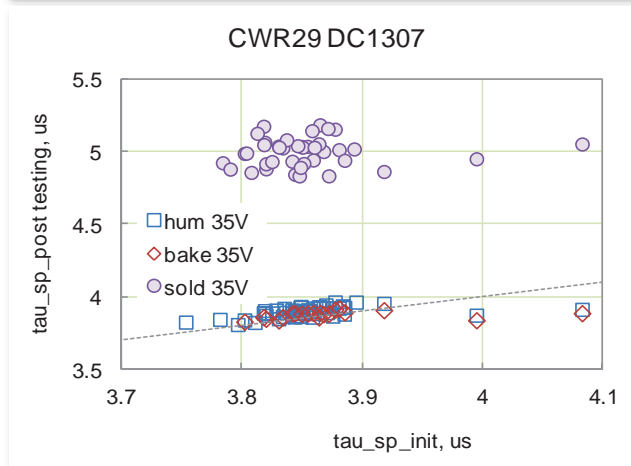
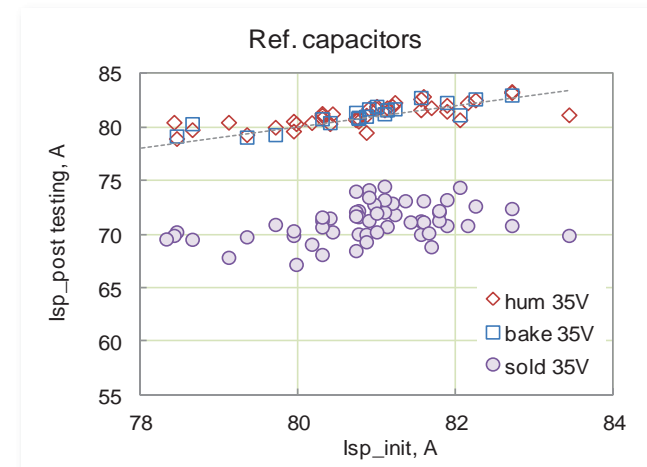

Similar correlation for current spike width

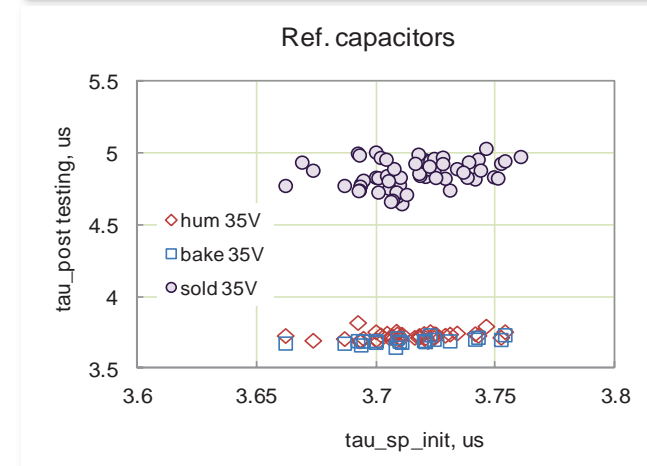

- ✓ SCT of soldered samples resulted in current spikes of a lesser amplitude (decrease ~10%) and greater width (increase ~30%).
- ✓ The result are due to increased ESR, and to using ~4" wires to interconnect the parts with the set-up that increased inductance of the circuit.

- ❑ Ten samples from each lot in “as is” condition were stressed by 3 cycles of TSD testing at a solder temperature of 350 °C, first at anode, and then at cathode sides.
- ❑ Post-TSD measurements were carried out in the sequence shown in the table.
- ❑ 60% of CWR29 capacitors failed the anode-side testing, whereas no reference parts failed.
- ❑ One CWR29 part had a substantial increase of DF.
- ❑ Two CWR29 parts recovered at higher voltages and passed SCT, but one failed DCL again after cathode-side testing.
- ❑ No failures happened after cathode side solder dip.

Test	TSD350 anode side		TSD350 cathode side	
	CWR29, DC1307	CWR09 Ref., DC1338	CWR29, DC1307	CWR09 Ref., DC1338
AC testing	0*/10	0/10	0/5	0/8
DCL at ≤15V	6/10	0/10	1/5	0/8
DCL at 35V	2/5	0/10	1/5	0/8
SCT at 15V	0/5	0/9**	0/5	0/9
SCT at 35V	0/5	0/8**	0/5	0/9

* DF = 4.4%; ** two samples were not tested by mistake

- ✓ Most failures happened at low voltages after anode-side thermal stress.
- ✓ Self-healed capacitors have a high risk of repeat failures.
- ✓ Parts with parametric DCL failures can pass surge current testing.
- ✓ Results are in agreement with the solder reflow test: soldering-related stresses affected CWR29 capacitors to a much greater degree than the reference parts.

Effect of TSD350 on AC and DC Characteristics

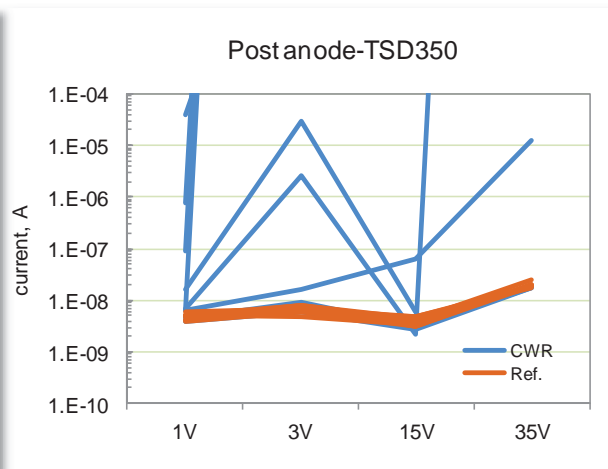
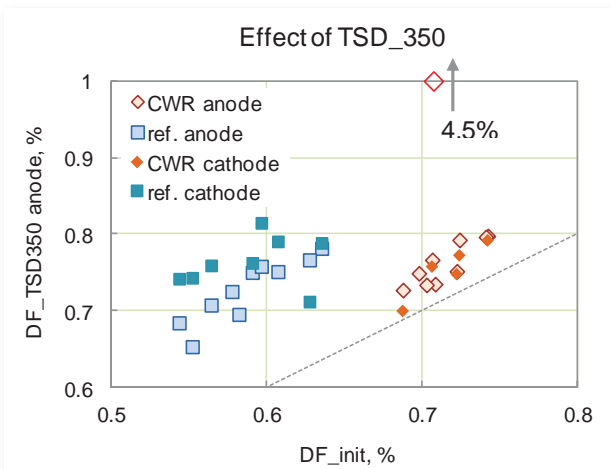
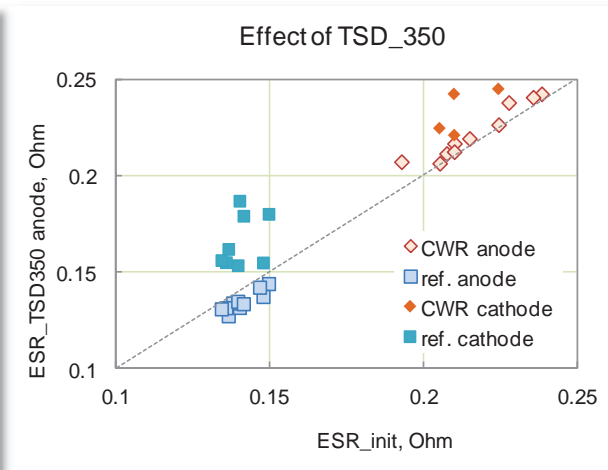
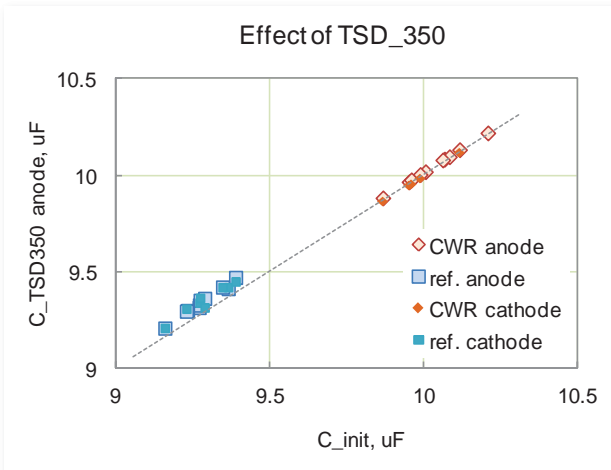

- ✓ All AC characteristics were within the specification.
- ✓ One CWR29 part increased DF almost an order of magnitude (this part had also large DCL at 1V).
- ✓ Anode-side TSD practically did not change ESR; whereas ESR increased on 11% in CWR and 18% in ref. capacitors (similar to the effect of reflow soldering).
- ✓ Two CWR29 parts failing DCL at 3V recovered at 15V, but then failed again at 35V.
- ✓ No degradation of DCL for the reference capacitors.

Effect of Soldering on Breakdown Voltages

- VBR for “moisture soak” and “as is” capacitors was measured with parts soldered onto PWB.
- “Bake, desoldered” parts were desoldered from the PI PWB, manually soldered onto FR4 PWB, and then desoldered again.
- Initial SCT failures were also used for calculations of VBR distributions.

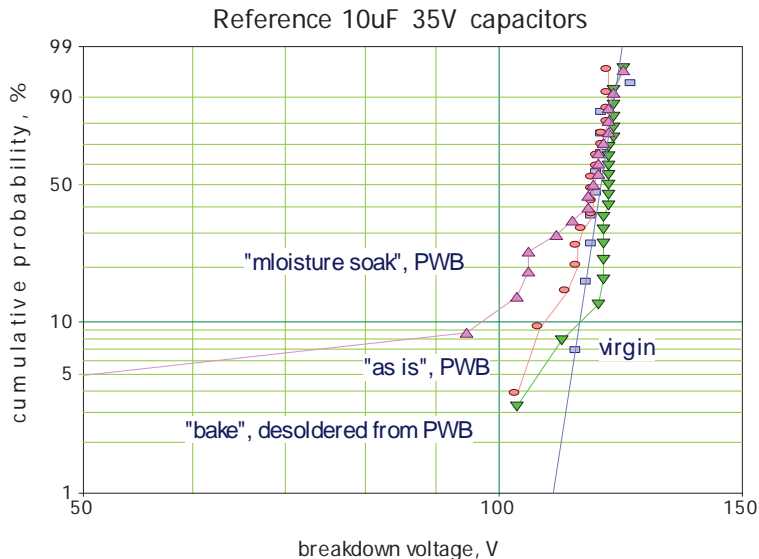
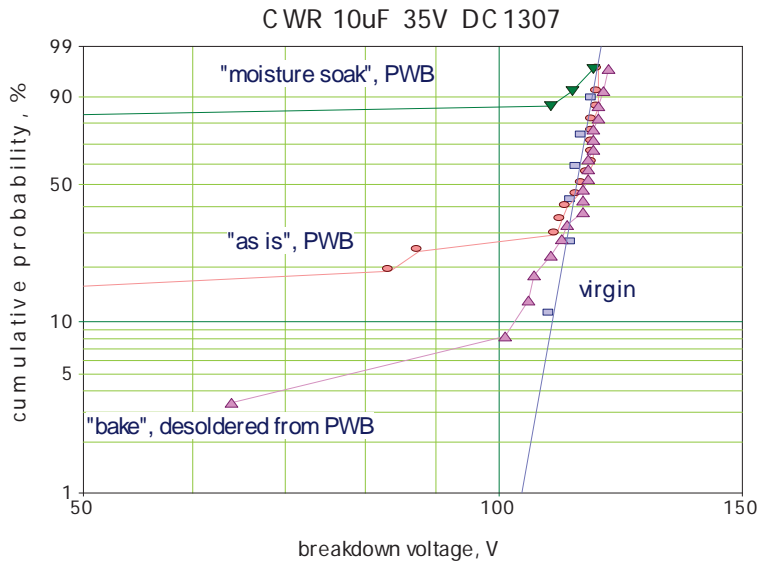

Results of VBR tests	CWR29		CWR09 (Ref.)	
	“as is”	Moist.	“as is”	Moist.
SCT short circuit	15 (93.7%)	3 (100%)	9 (45%)	10 (55.6%)
SCT self-healed	1 (6.3%)	0	11 (55%)	8 (44.4%)
Sample size	16	3	20	18
Median VBR, V	112.7	113.3	116.5	115.2

- ✓ Most non-failed parts had intrinsic VBRs.
- ✓ Tails of the distributions indicate defects in Ta_2O_5 .
- ✓ There is a trend of increasing the number of defects after soldering capacitors with greater moisture content.
- ✓ Desoldering can cause damage to dielectric.
- ✓ 95% of CWR95 parts failed short circuit, whereas ~50% of the reference parts self-healed after scintillation breakdown.

IR Images of Capacitors Failed after Reflow Soldering



CWR29 capacitors soldered after moisture soak

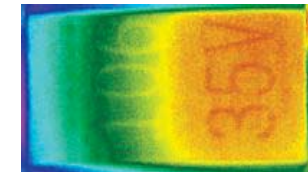
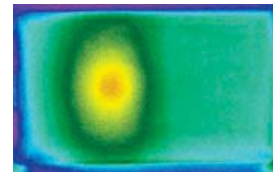
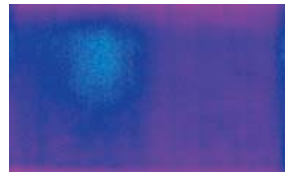
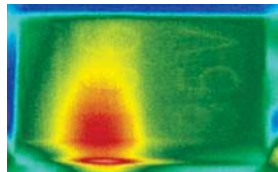

SN62 failed SCT, 1.5Ω; SN68 failed SCT, 0.7Ω; SN72 failed SCT, 1.3Ω; SN66 after VBR=113V, 1.3Ω

CWR29 capacitors soldered in “as is” condition

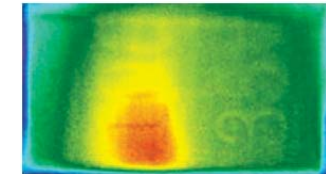
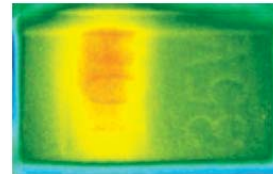
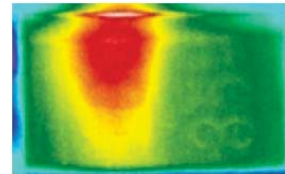
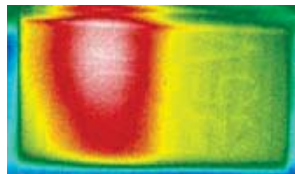

SN46 failed I-t@35V, 62Ω; SN53 failed SCT, 1.6Ω; SN54 failed SCT, 3.9Ω; SN56 failed SCT, 1.2Ω

CWR09 (Ref.) capacitors after moisture soak

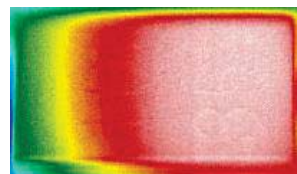
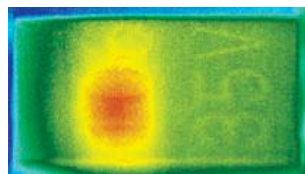

SN56 failed SCT, 3.1Ω; SN60 high DCL, VBR=110V

- ✓ All tested parts that failed catastrophically after soldering had damage at the riser wire shoulder.
- ✓ Parts that failed after breakdown testing had damage under the internal portion of the cathode lead frame.

IR Images of Reflow Soldered Capacitors after VBR Measurements

Three CWR29 samples soldered in “as is” condition and 6 reference capacitors soldered after moisture soak were examined after VBR testing.



Typical X-ray view showing location of internal part of cathode terminal

CWR29 capacitors soldered in “as is” condition

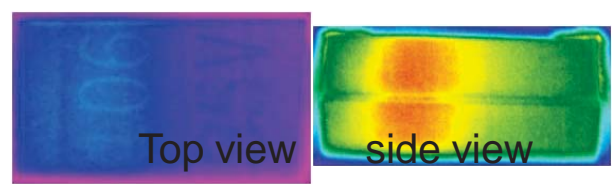

Top view
side view
SN41, VBR=118V;

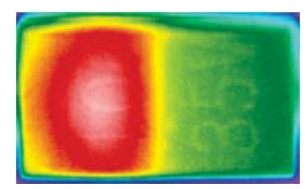

SN42, VBR=112V

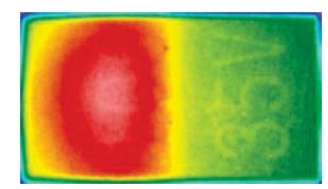

SN43, VBR=119V

CWR09 (Ref.) capacitors soldered after moisture soak

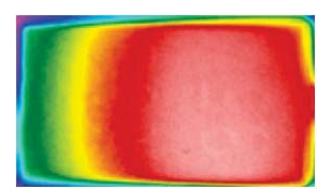

SN43, VBR=120V;

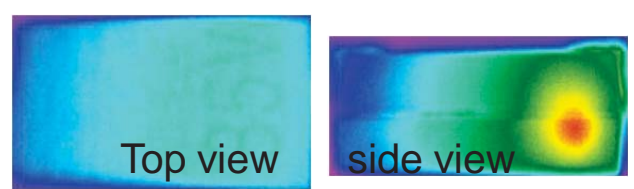

Top view
side view
SN44, VBR=94.7V

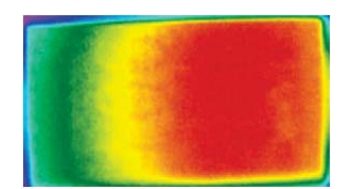

SN47, VBR=116V

✓ After breakdown tested CWR29 capacitors had damage at the anode side, whereas all reference capacitors had damage at the cathode side.

IR Images of Capacitors after TSD350

IR images were taken for 6 CWR29 and 3 reference capacitors after SCT.

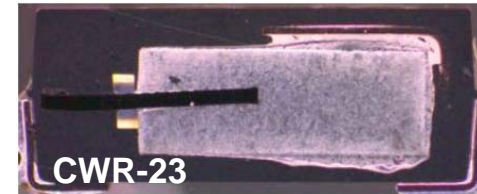

CWR29 capacitors

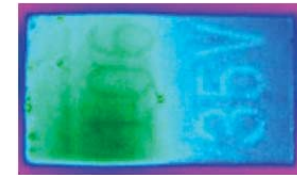
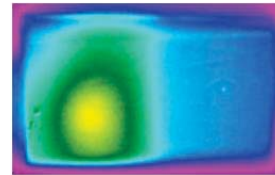
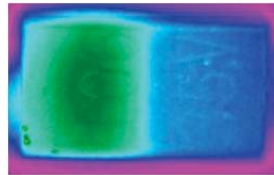
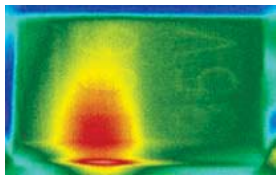

SN21 failed SCT, 98.7Ω ; SN22 failed SCT, $2.3k\Omega$; SN23 failed SCT, $5.2k\Omega$; SN24 high DCL, VBR=50V

CWR09 (Ref.) capacitors

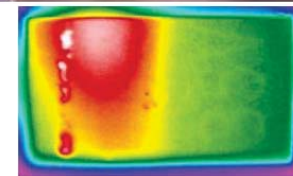
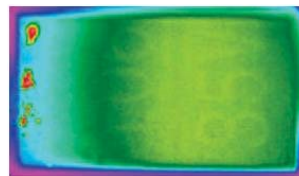
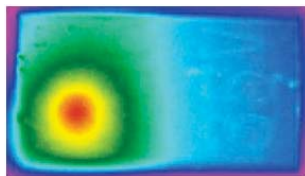
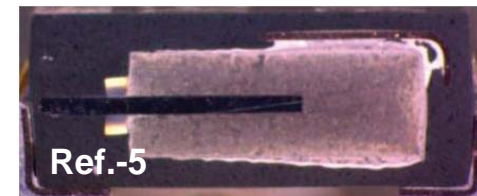

SN1, failure suspect*, VBR = 113V; SN5, failure suspect*, VBR=115V; SN10, normal, VBR=140V

* The part was not tested properly by SCT, but passed all following tests.

- ✓ All parts except for one reference capacitor had damage at the riser wire shoulder of the anode slug.
- ✓ Reference capacitor SN1 most likely failed at the anode-side corner of the slug.

Results of Cross-Sectioning

Parts failed after reflow soldering have been cross-sectioned in small steps in the attempt to reveal damaged area.

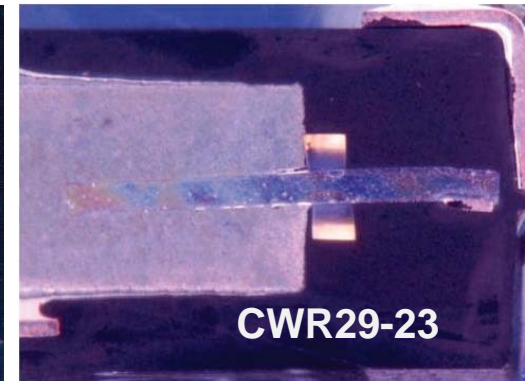
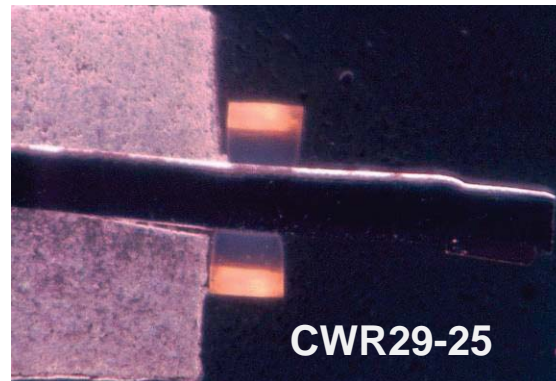
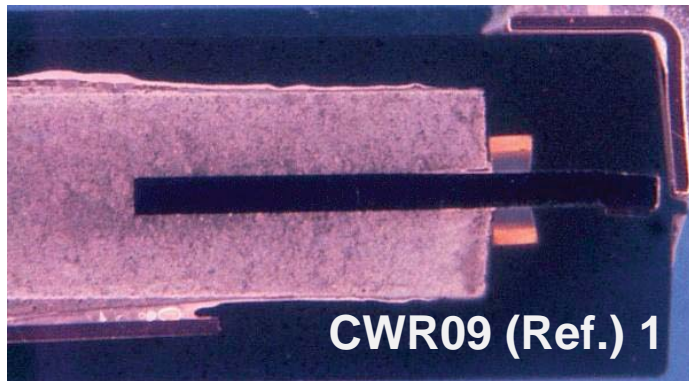
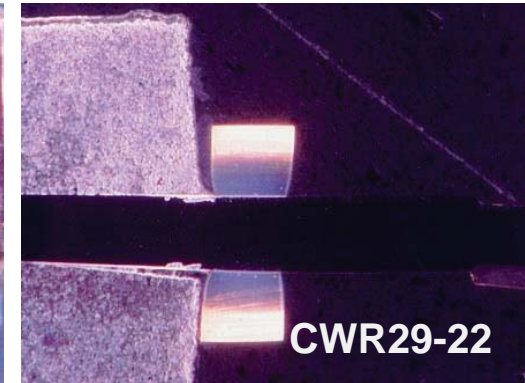
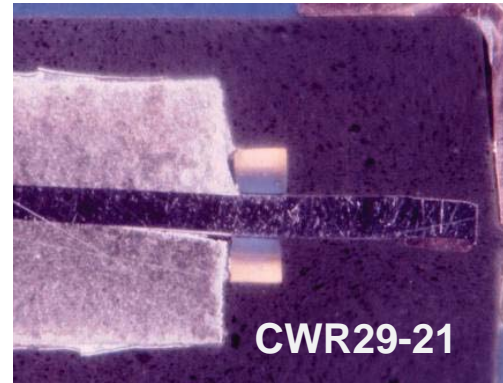
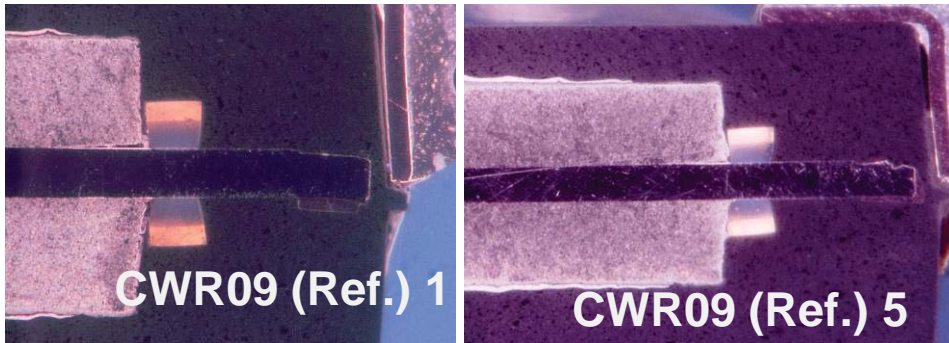

- ✓ No substantial difference between CWR29 and reference parts.
- ✓ Delaminations between riser wires the slugs was observed in both part types.
- ✓ No obvious defects that might be associated with failures were detected.

SEM Images and X-ray Mapping CWR29

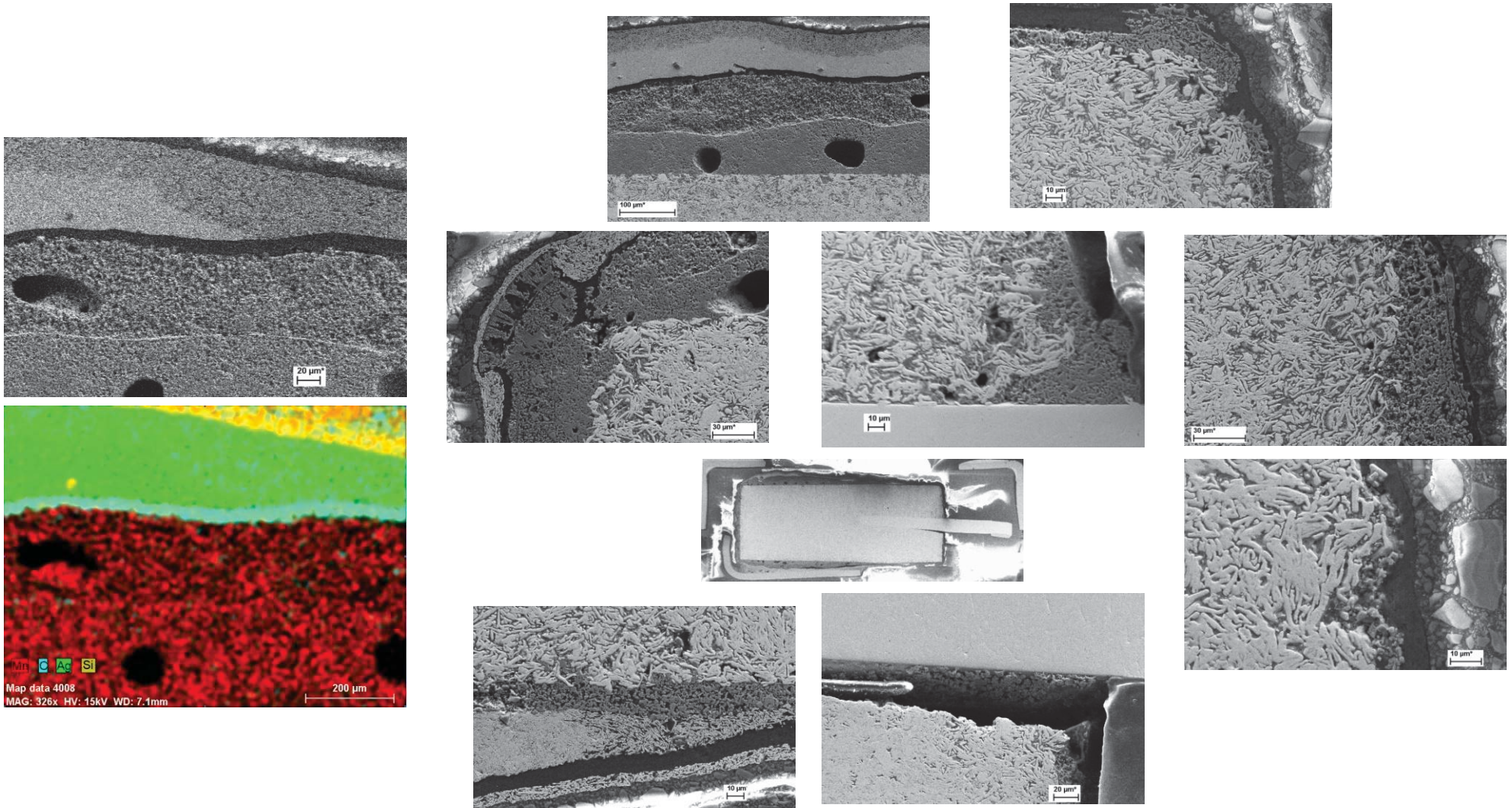

- ✓ No anomalies observed, good coverage of the slug with MnO₂ and carbon.
- ✓ The riser wire shoulder had a thin layers of MnO₂ and carbon coatings.

SEM Images and X-ray Mapping for CWR09 (Ref.) Capacitors

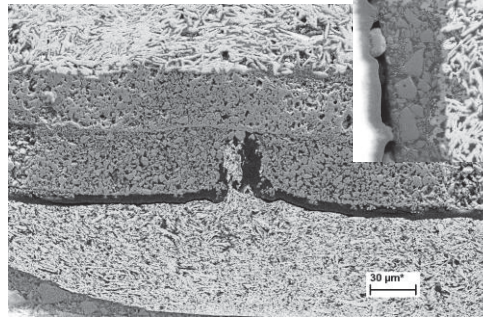
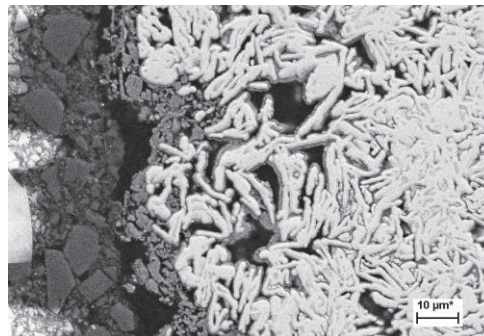
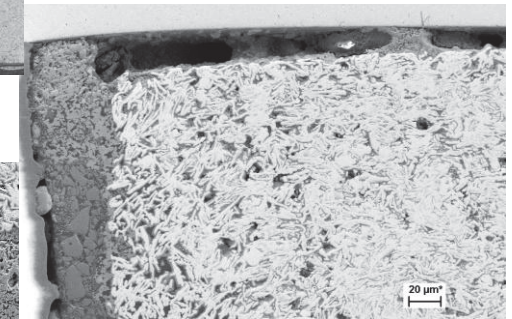
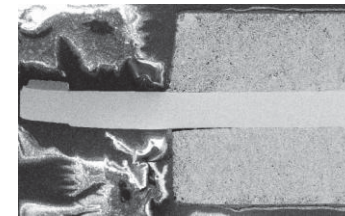
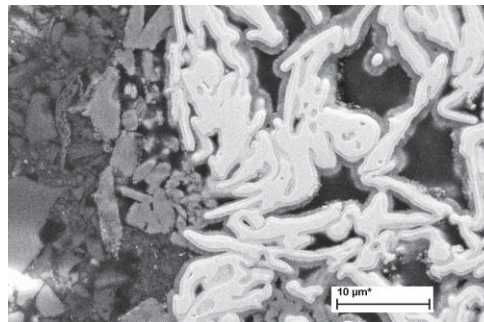
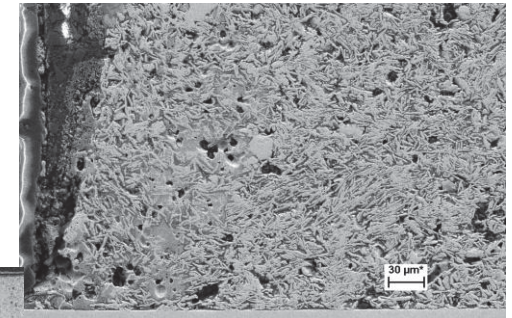
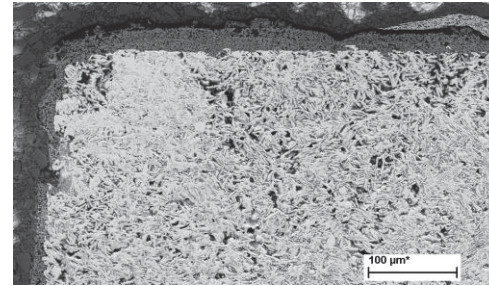
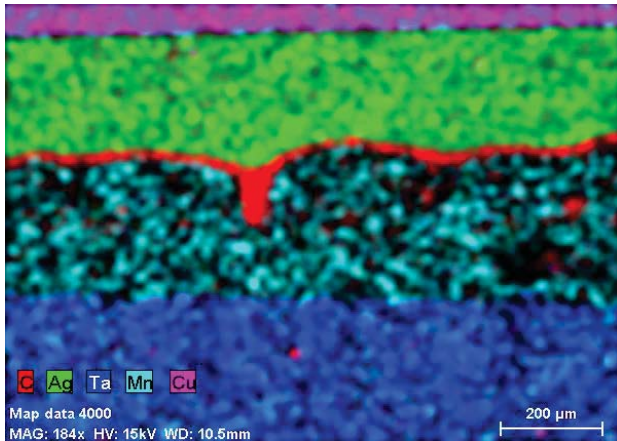
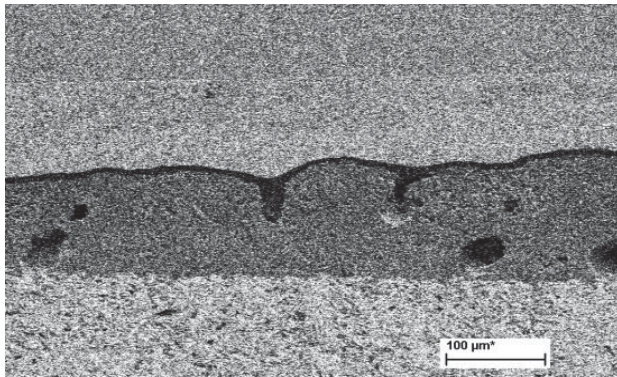

- ✓ Results for reference parts were similar to CWR29 capacitors.
- ✓ SEM and EDS analysis of cross-sectioned samples were not successful in revealing defects that might be responsible for the difference in behavior of CWR29 and reference capacitors.

Discussion

- ❑ During manufacturing both lots, CWR29 and CWR09 were solder dipped to form Sn/Pb finishing on the terminations and stressed by the solder reflow simulation. However, similar stresses during our testing resulted in substantial fall-outs.
- ❑ The difference between solder reflow simulation during screening and actual soldering conditions is due to the moisture content in the parts: during manufacturing the amount of moisture in capacitors is minimal, whereas after a few months of storing the parts at room conditions the amount of moisture increases substantially.
- ❑ Post-soldering failures observed in this study happened at voltages below 50% VR, so voltage derating is not a panacea.
- ❑ To understand the mechanism of pop-corning failures and preventive measures, we need to analyze moisture characteristics of used materials. Moisture in chip tantalum capacitors is mostly absorbed in MC and manganese, and condensed in micropores of the slug and microcracks/delaminations between different cathode and case materials.

Moisture Diffusion in Tantalum Capacitors

- Temperature dependence of the diffusion coefficient, $D(T)$, was measured on samples of molding compounds (MC) using a non-isothermal gravimetric technique [14].
- Similar results can be obtained by analysis of isothermal sorption kinetics.

Example of moisture sorption kinetics

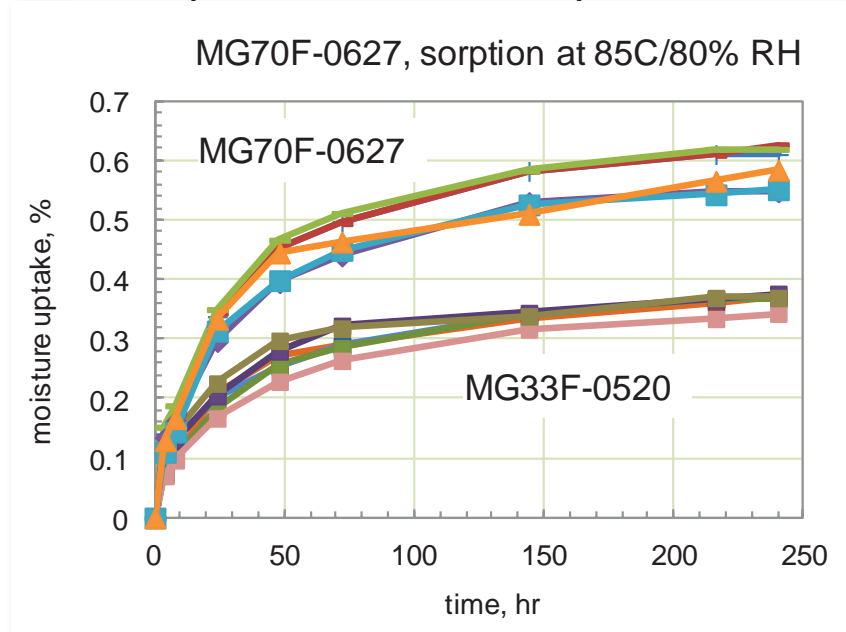

Moisture diffusion coefficients

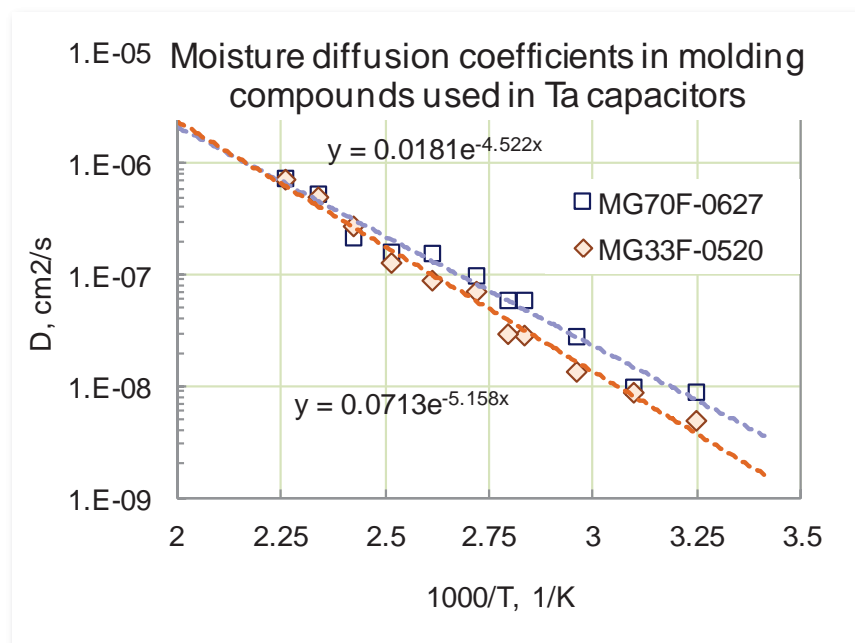

- ✓ The values and activation energies of diffusion processes for epoxy molding compounds used for tantalum capacitors are similar to characteristics of molding compounds used for microcircuits [15].

Bake-out Times for Tantalum Capacitors

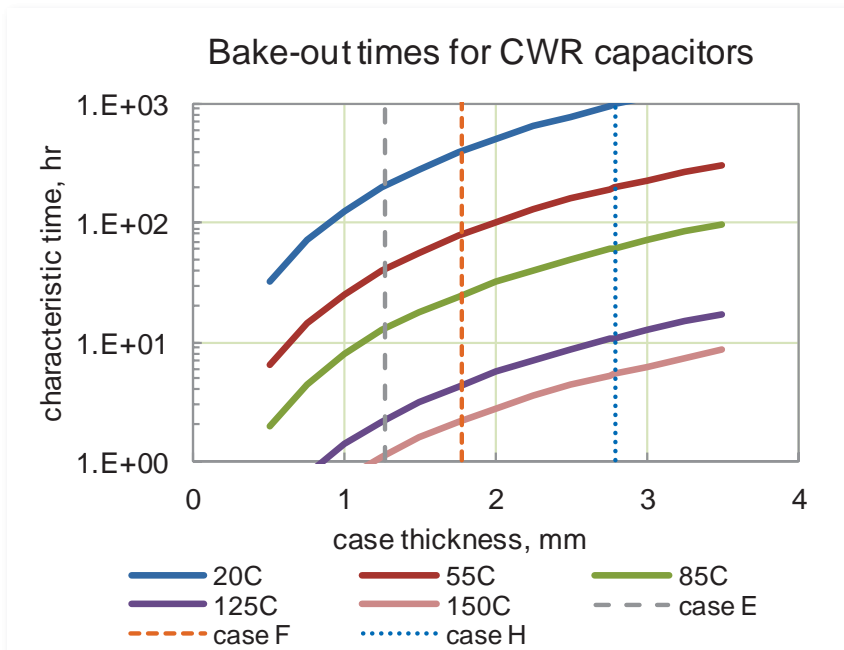

Assuming the thickness of molding compound is $\sim 1/3 H$, the bake times can be calculated as [16]:

$$\tau(T) = 0.1 \times \frac{H^2}{D(T)}$$

H is the thickness of the package;
D(T) is the coefficient of moisture diffusion.

- ✓ The bake time corresponds to a time that is required to release $\sim 90\%$ of the absorbed moisture.
- ✓ Based on $D(T)$ for molding compounds used in tantalum capacitors, for case H parts ($H = 2.8\text{mm}$), bake-out times are 1000 hr, (~ 1.5 month), 200 hr (1.2 wk), 62 hr, and 11 hr at 20°C , 55°C , 85°C , and 125°C respectively.
- ✓ Note that the bake-out time at 150°C is ~ 5.5 hr, which is far longer than the preheating step during soldering (~ 1 min at 150°C).
- ✓ Overnight baking at 125°C (15 hours) should be sufficient to remove moisture from most types of capacitors.
- ✓ Soldering capacitors within 48 hours after bake or removal from a dry bag should not cause pop-corning related failures.

Moisture in Tantalum Capacitors

- ❑ Moisture sorption in silver epoxy, ~0.1% [17], is far less than in MC (~0.5%).
- ❑ Manganese covers the slug and fills the pores.
- ❑ The volume of pores was determined by calculating the density of slugs used in different case CWR capacitors and comparing with the density of Ta (16.7 g/cc).

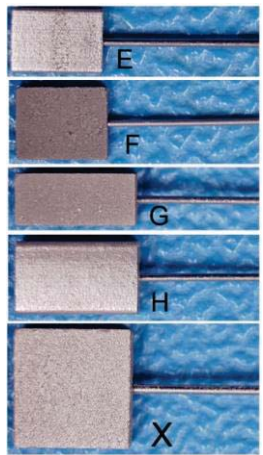

CWR29 case	L, mm	W, mm	t, mm	surface area, mm ²	slug volume, mm ³	slug mass, g	slug density, g/cc	porosity %
E	2.8	0.6	2.0	16.8	3.3	0.021	6.3	56.1
F	3.3	0.6	2.6	24.5	5.4	0.028	5.3	61.5
G	4.5	2.0	2.0	43.2	17.3	0.113	6.5	54.9
H	4.6	1.6	2.7	48.7	19.9	0.128	6.5	55.2
X	4.5	1.5	4.5	68.4	31.0	0.174	5.6	59.8

- ✓ Pores in the slugs comprise from 55% to 60% of the slugs' volume.
- ✓ Most part of the pores' volume is filled with manganese.
- ✓ Most moisture is absorbed in MC, MnO₂, and pores of the anode slug.

Moisture Content

Moisture content was calculated in the following assumptions:

- Moisture uptake in MC at 85%RH is ~0.5%.
- The thickness of MnO₂ layer on the slug is ~ 0.1mm.
- MnO₂ occupies 50% of the volume of pores.
- Moisture uptake in MnO₂ at 85%RH is ~2% [18].

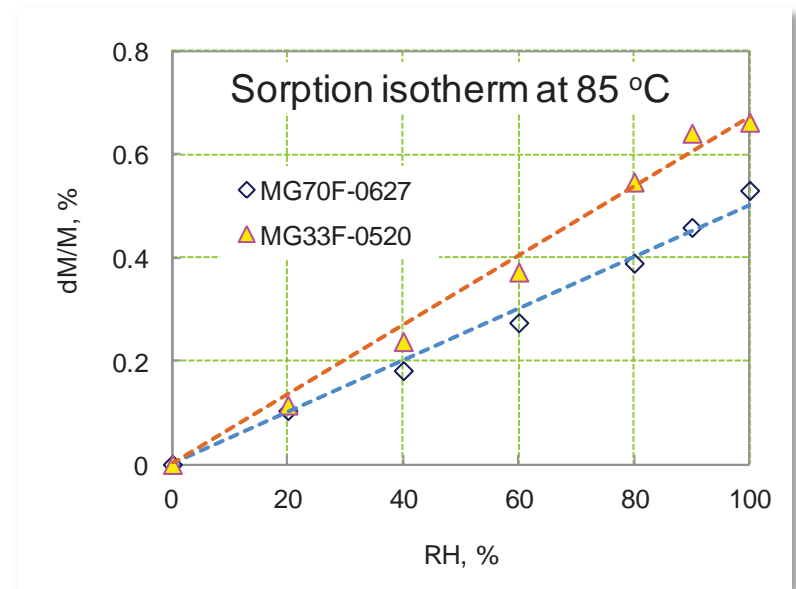

CWR29 case	volume, mm ³					mass, g			moisture, g		
	case	slug	pores	MC	MnO ₂	case	MC	MnO ₂	MC	MnO ₂	total
E	16.4	3.4	1.9	11.7	2.6	0.06	0.02	0.01	1.1E-04	2.6E-04	3.8E-04
F	34.1	5.5	3.4	25.8	4.1	0.11	0.05	0.02	2.5E-04	4.1E-04	6.6E-04
G	52.4	17.5	9.6	31.4	9.1	0.18	0.06	0.05	3.0E-04	9.1E-04	1.2E-03
H	77.0	20.0	11.1	51.2	10.4	0.31	0.10	0.05	4.9E-04	1.0E-03	1.5E-03
X	102.7	31.2	18.8	64.3	16.2	0.37	0.12	0.08	6.1E-04	1.6E-03	2.2E-03

- ✓ The calculated amount of moisture for case H capacitors, $\sim 1.5 \times 10^{-3}$ g, corresponds to experimental data $(3 \text{ to } 9) \times 10^{-4}$ g. Most likely, actual amount of moisture is greater than the one determined by baking.
- ✓ The amount of moisture condensed in pores of the slug filled with MnO₂ is comparable with the amount of moisture absorbed in MC.

Failure Mechanism

- ❑ The following results indicate that soldering stresses cause local mechanical damage (fracture of the dielectric):
 - No substantial variation of AC characteristics.
 - No degradation of DCL for most of the parts.
 - Most of failures occurred at low voltages.
 - Increase of the low-voltage tails in VBR distributions.

- ❑ During soldering, moisture condensed in cracks, pores, or MnO₂ evaporates rapidly creating high local pressure in the sponge-like structure of Ta anode and increasing delamination between MC and slug. When this pressure is applied to a mechanically weak site of the slug, a fracture of Ta₂O₅ dielectric occurs. This effect can be defined as internal popcorning.

- ❑ In some cases damage can be self-healed (e.g. by oxidation of Ta, or increasing resistance of MnO₂). This might improve temporarily characteristics of the part, but reliability of such a part is compromised.

Schematic of local popcorning that can cause cracking in Ta₂O₅ dielectric

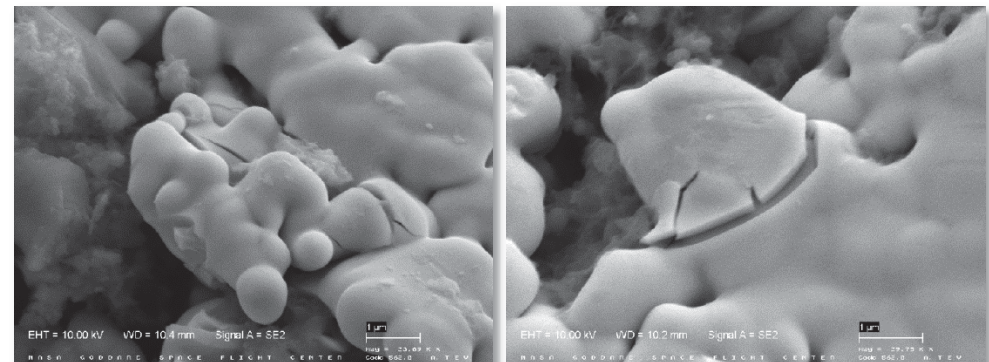
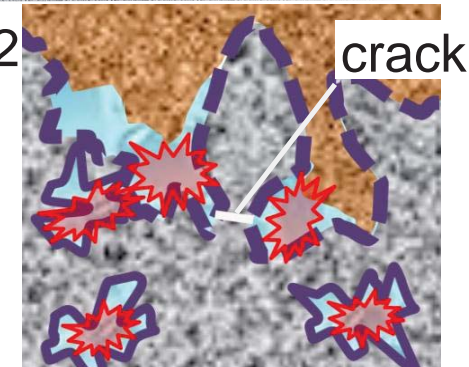
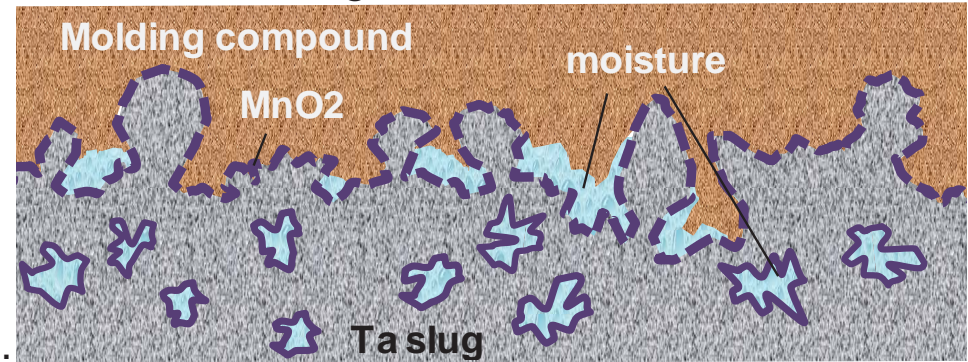

Examples of cracks in the dielectric of 6.8uF 35V CWR11 capacitors

Failure Mechanism: Effect of Surge Currents

- ❑ Chip-outs and cracks in the case were not observed after soldering, but occurred after surge current testing in CWR29 capacitors preconditioned by moisture soak.
 - Based on temperature dependence of moisture diffusion, bake-out time at 220C is ~ 1 hr, which exceeds substantially the time of high-temperature exposure during soldering (a few seconds).
 - This might indicate that case cracking is due to moisture remaining in the parts after soldering and overheating of the moisture containing MnO₂ layers by surge currents.
- ❑ It is possible that the surge current power overheats MnO₂ layer causing absorbed moisture to evaporate quickly and result in popcorning.
 - The amplitude of surge current spike at 15V is ~ 35A. Considering that DC resistance during spike is close to ESR, the dissipated power is ~6.1 kW. However, during ~ 3 μs (duration of spikes) only ~ 0.02 J of energy will be generated.
 - Due to a short duration of the spike, the energy will be generated adiabatically, and mostly in the MnO₂ layer on the surface of the slug. At the specific heat capacity of MnO₂ 53 J/(K**mol*) [19], *M* = 87g/*mol*, and the mass ~0.05g, the temperature increase is below 1°C, which is in agreement with [20].
 - Estimations show that overheating of MnO₂ is not the major cause of pop-corning.
- ❑ Most likely, overheating occurs locally, in a relatively small area where a defect (crack in Ta₂O₅ dielectric) has been formed during the solder reflow process. The case fracture (popcorning) is caused by a local instant heat release that creates high thermo-mechanical and water vapor stresses in the case.

Failure Mechanism, Cont'd

- All revealed damage sites were located at the riser wire shoulder of the slug. Possible reasons for this location:
 - This area is considered most susceptible to soldering-related failures because of high level of mechanical stresses caused by the CTE mismatch with molding compound [5]. Moisture-related swelling and shrinking of MC increases the level of stress substantially [21].
 - All other surfaces of the slug are “sealed” with silver epoxy that is compressed to the slug by molding compound.
 - The riser wire shoulder is covered by a thin layer of MnO₂ and is close to a large volume of MC. This makes delamination between MC and slug in this area more likely.
 - The presence of delamination facilitates movements and fracture of weak sites of the slug.
 - The vapor flow from the slug along the delamination would create additional stress to the weak sites at the riser wire shoulder.
- The reason why the reference lot is less moisture sensitive compared to LDC1307 capacitors is not clear. It is possible that some variations in the manufacturing process (e.g. during slug formation and sintering, assembly onto lead-frames, encapsulation with MC, etc.) result in lots with different proportion of potentially weak sites on the surface of the slug that are susceptible to damage by internal popcorning.

Example of weak sites on the surface of CWR11 capacitors

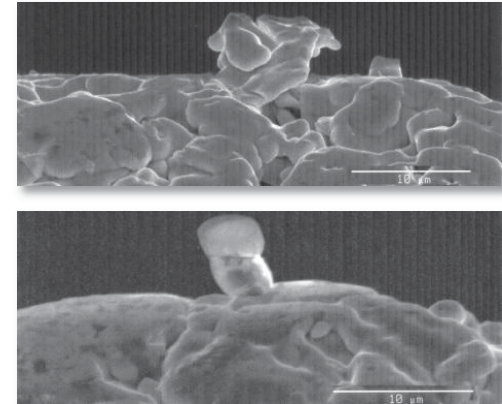

Schematic of popcorning-induced damage

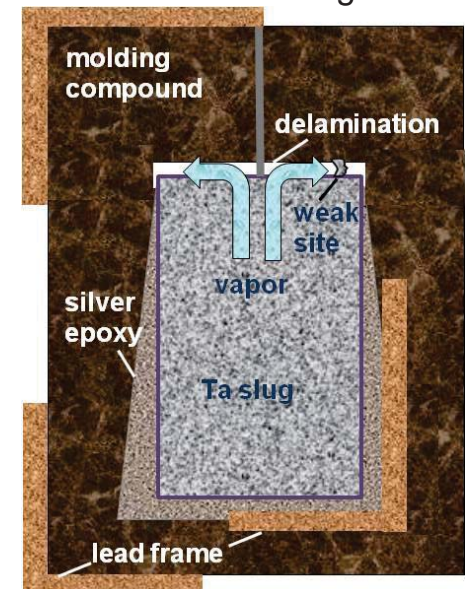

Summary: Effect of Reflow Soldering

- ❑ The probability of post-soldering failures depends strongly on preconditioning suggesting an important role of absorbed moisture in post-soldering failures. No failures occurred in baked capacitors, whereas 85% of CWR29 and 5% of reference parts that were soaked with moisture failed.
- ❑ Different lots of chip tantalum capacitors have different susceptibility to soldering-related failures.
- ❑ Popcorning in chip tantalum capacitors might result in cracking of the molding compound and/or in internal damage to the dielectric (internal popcorning).
- ❑ The majority of post-soldering failures occurred at low voltages indicating that voltage derating might not protect against soldering-related failures.
- ❑ Reflow soldering increases ESR on 11% -16% in baked parts, 29% to 46% in capacitors with moisture, and on ~18% in capacitors after long-term storage at room conditions.

Summary: Effect of Environments

- Moisture soak did not degrade characteristics of capacitors before soldering suggesting that the presence of moisture is much more dangerous for the soldering process compared to the post-soldering conditions.
 - Even a relatively small amount of moisture that is absorbed in capacitors stored at room conditions can result in post-soldering failures (20% for CWR29 capacitors), but normally, this amount of moisture does not cause failures during operation.
 - A more dangerous situation might occur if failures are not revealed right after soldering, but the created damage cause failures with time of operation.
- Moisture diffusion and sorption in chip tantalum capacitors has been characterized and bake-out conditions were determined based on temperature dependence of moisture diffusion in molding compounds.
 - Although bake-out times decrease with the size of capacitors, to simplify conditioning process, it is recommended that all parts are baked at 125 °C for 15 hours.
 - The amounts of moisture absorbed in MC and in MnO₂ layers at the surface and in pores of the slug are similar.

Summary, Mechanism of Failures

- ❑ Post-soldering failures are due to a local mechanical damage to the Ta₂O₅ dielectric. Soldering-induced damage is a result of thermal-shock-related mechanical stresses that have been increased by the presence of moisture due to swelling and shrinkage of MC and via the internal popcorning effect.
- ❑ All failed capacitors had damage at the riser wire shoulder of the anode slug. This damage was likely caused by preexisting defects that had not been detected by screening.
- ❑ The probability of damage depends on the specific features of the sample (e.g., irregularities on the surface of the slug). However, the proportion of samples with high likelihood of being damaged by soldering depends on the manufacturing lot.
- ❑ Cracking of molding compound might be due to surge currents during first power turn-on after soldering capacitors containing moisture.
- ❑ Increase in ESR after soldering is most likely due to thermo-mechanical stresses that result in delaminations between cathode layers. For baked parts, the increase is 10% to 16%, but for capacitors soaked in moisture it increases to 29% to 46%.

Summary: Effect of Manual Soldering

- ❑ Results of terminal solder dip testing are in agreement with the results of solder reflow test.
 - Most CWR29 capacitors (60%) failed at low voltages, whereas there were no failures for reference parts.
 - The results confirmed the effectiveness of the terminal solder dip testing (TSD350) for evaluation of the susceptibility of tantalum capacitors to damage by soldering stresses.
- ❑ All catastrophic failures occurred when the anode terminal was thermally stressed by touching molten solder at 350 °C.
 - Similar to reflow soldering, all failures were due to damage at the riser wire shoulder of the slug.
 - Anode-side stresses did not affect ESR.
- ❑ Cathode-side stresses increased ESR by 11% to 18%.
 - The result is similar to reflow soldering and is also most likely due to delaminations between cathode layers.

Summary: Recommendations for Qualification Testing

- ❑ Soldering simulation tests that are used as a part of screening during manufacturing are carried out using freshly made capacitors with minimal amount of moisture and do not simulate soldering conditions for the capacitors that have been stored in non-dry environments for a long period of time.
- ❑ Life test during qualification should be carried out after preconditioning per the relevant MSL and reflow soldering onto PWBs using recommended profiles.
- ❑ Measurements of AC characteristics through the testing showed that they are much less sensitive to the presence of defects compared to DCL and VBR.
 - The sensitivity to local defects increases in the sequence: AC tests << DCL < VBR.
 - Surge current test, as well as 5 min measurements of DCL, C, DF, and ESR are recommended to verify MSL of tantalum chip capacitors.
- ❑ Qualification testing to verify MSL 1.
 - Precondition 20 capacitors per JESD22-A113 at 85°C, 85%RH for 168hrs;
 - Within 4 hrs after removal from humidity chamber, solder the samples using reflow temperature profile recommended by the manufacturer.
 - Subject the sample to 3 cycles of solder reflow with 10 min intervals for boards to cool down.
 - Post-soldering tests should be carried out in the sequence: optical examination at 10X, SCT, AC and DCL measurements.
 - No cracking or electrical failures allowed.

Summary: Conditioning before Soldering onto Flight Boards

- ❑ Parts in dry bags sealed by manufacturers can be used within 48 hours after removing from the bags provided reading of humidity indicators are acceptable.
- ❑ All solid chip tantalum capacitors that were not stored in dry conditions should be baked for 15 hours at 125°C and used within 48 hrs after bake.
- ❑ After the bake or removal from the sealed bags, if necessary, the parts can be stored in dry boxes (RH < 10%).

References

- [1] J. D. Prymak, *et al.*, "Proofing Tantalum Capacitors and Effects on Reliability," in *The 26th symposium for passive components, CARTS Europe'05*, Prague, CZ Republic, 2005, pp. 171-178.
- [2] J. Marshall and J. Prymak, "Surge step stress testing of tantalum capacitors," in *21st Capacitors and Resistors Technology Symposium, CARTS'01*, 2001, pp. 181-187.
- [3] R. Hahn, *et al.*, "Improved SMT Performance of Tantalum Conductive Polymer Capacitors with Very Low ESR," in *The 26th symposium for passive components, CARTS'06*, Orlando, FL, 2006, pp. 291-303.
- [4] A. Teverovsky, "Effect of Temperature Cycling and Exposure to Extreme Temperatures on Reliability of Solid Tantalum Capacitors," in *CARTS'07, the 27th Symposium for Passive Components*, Albuquerque, NM, 2007, pp. 279-306.
- [5] D. M. Edson and J. B. Fortin, "Improving thermal shock resistance of surface mount tantalum capacitors," in *14th Capacitors and Resistors Technology Symposium*, Jupiter, FL, 1994, pp. 169-176.
- [6] J. Virkki, *et al.*, "Testing the effects of reflow on tantalum capacitors," *Microelectronics Reliability*, vol. 50, pp. 1650-1653, Sep-Nov 2010.
- [7] A. Teverovsky, "Effect of Environmental Stresses on Breakdown Voltages in Chip Tantalum Capacitor.," in *The 28th Symposium for Passive Components, CARTS'09*, Jacksonville, FL, 2009, pp. 293-310.
- [8] A. Teverovsky, "Terminal Solder Dip Testing for Chip Ceramic and Tantalum Capacitors," in *International Conference on Soldering & Reliability (ICSR)* Ontario, Canada, 2012, pp. 163-173.
- [9] R. Dobson, "Surface mount solid tantalum capacitor new wear-out mechanism," in *CARTS'03, 23rd Capacitor and Resistor Technology Symposium*, Scottsdale, Arizona, 2003, pp. 141-148.
- [10] GIDEP alert G2-P-09-01, "CWR09 external body cracks", 2009 .
- [11] D. Amir, "Capacitor induced BGA assembly failures," in *SMTA International, 2000*. Available: http://www.smta.org/knowledge/proceedings_abstract.cfm?PROC_ID=539

References, Cont'd

- [12] W. Winkel and E. Rich, "High Reliability Principles and Verifications in Solid Tantalum Capacitors. End-User's Manufacturing Processes," in *CARTS International*, Santa Clara, CA, 2014.
- [13] J. Moore, J. Prymak, and N. Reynolds, "Moisture - An Old and Known Nemesis of Tantalum Caps", KEMET Tantalum Applications. 2000, Available:
<http://www.kemet.com/Lists/TechnicalArticles/Attachments/184/Moisture%20Barrier.pdf>
- [14] A. Teverovsky, "Moisture Characteristics of Molding Compounds in PEMs", NEPP Report. 2002, Available: <https://nepp.nasa.gov/DocUploads/B9C0B2A1-4C69-4CB5-94863C560CBB0B19/Moisture%20Characteristics%203-part%20NEPP%20report.doc>
- [15] A. Teverovsky, "Effect of Moisture on Characteristics of Surface Mount Solid Tantalum Capacitors," in *CARTS'03, 23rd Capacitor and Resistor Technology Symposium*, Scottsdale, Arizona, 2003, pp. 96-111.
- [16] A. Teverovsky, "Characteristic Times of Moisture Diffusion and Bake-out Conditions for Plastic Encapsulated Parts", NEPP Report. 2002, Available: http://nepp.nasa.gov/index_nasa.cfm/477/
- [17] H. T. Wang and Y. C. Poh, "An analysis on the properties of epoxy based die attach material and the effect to delamination and wire bondability," in *Electronic Manufacturing Technology Symposium (IEMT), 2008 33rd IEEE/CPMT International, 2008*, pp. 1-6.
- [18] C.-N. Xu, et al., "Humidity sensors using manganese oxides," *Sensors and Actuators B: Chemical*, vol. 46, pp. 87-96, 1998.
- [19] K. T. Jacob, A. Kumar, G. Rajitha, et al., "Thermodynamic Data for Mn₃O₄, Mn₂O₃ and MnO₂," *High Temperature Materials and Processes*, vol. 30, pp. pp. 459–472, 2011.
- [20] E. K. Reed, "Tantalum chip capacitor reliability in high surge and ripple current applications," in 44th. *Electronic Components and Technology Conference*, 1994, pp. 861-868.
- [21] A. Teverovsky, "Environmentally Induced Swelling and Shrinkage of Molding Compounds in PEMs," GSFC, Greenbelt MD, 2002, Available: <https://nepp.nasa.gov>