



Fundamentals of Cryogenics

Wesley Johnson, Thomas Tomsik, and Jeff Moder

25th Annual TFAWS

August 4, 2014



Agenda

- Introduction (30 min)
- Hardware (1 hour)
- Video – When Space Came down to Earth (~30 min)
- Lunch Break (~1 hour)
- Testing (45 min)
- Modeling/Analysis (45 min)
- Summary/Questions



Instructors

Wesley Johnson

Wesley.L.Johnson@nasa.gov

(216) 433-6913

Thomas Tomsik

Thomas.M.Tomsik@nasa.gov

(216) 977-7519

Jeff Moder

Jeffrey.P.Moder@nasa.gov

(216) 433-8254

Glenn Research Center



Wesley Johnson

- Ten years hands on experience with liquid nitrogen and other cryogenic fluids
 - KSC
 - GRC
- BAE/Auburn University
- MSAE/Univ. Central Florida
- Past Experience:
 - Cryogenic Propellant Storage and Transfer TDM Science Team
 - AES Liquid Hydrogen Ground Operations Demonstration
 - Methane Lunar Surface Thermal Control testing science team
 - 10 years of insulation thermal performance testing & test design
 - Space Shuttle Return to Flight
 - Co-Chair 2011 Space Cryogenics Workshop
 - Trouble shooting & improvement of operations at KSC launch pads



Thomas Tomsik



NASA
C-2004-1259

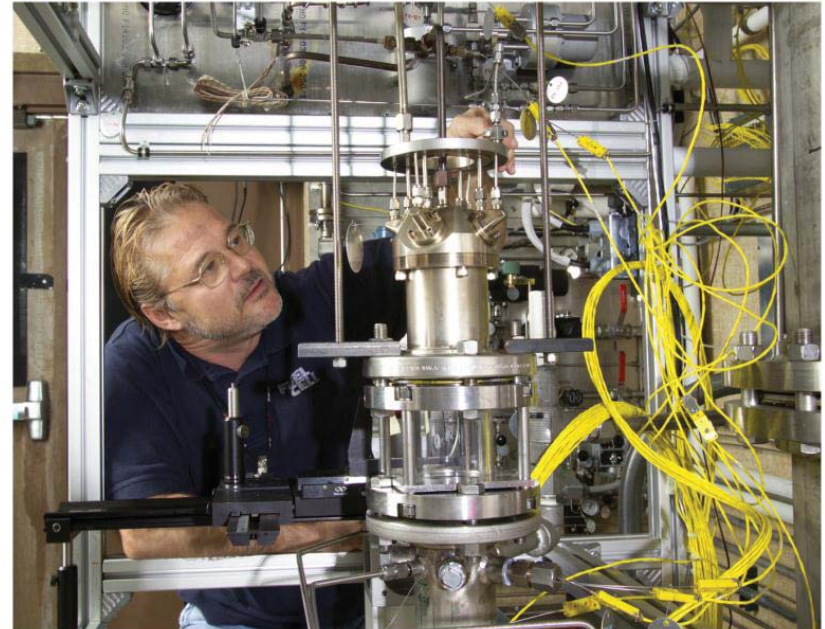

- Thirty years experience in research, testing/operations, & design of cryogenic systems
- BS/MS Chem Eng Cleveland State University
- P.E. in State of Ohio
- Past Experience:
- Cryogenic Propellant Storage and Transfer TDM
- AES Liquid Hydrogen Ground Operations Demonstration
- X-33 Densified Hydrogen & Oxygen Systems
- NASP Single Stage to Orbit Test bed
- Slush H₂ Tech Dem – K-Site, Plum Brook Test
- SMiRF design for multiple testing systems





Jeff Moder

- Seven years experience in modeling cryogenic systems and over twenty years experience in modeling multi-phase systems
- BS AE/Case Western Reserve Univ.
- PhD AE/Rensselaer polytechnic institute
- Past Experience:
 - Evolvable Cryogenics project Analysis Tools Lead
 - Cryogenic Propellant Storage and Transfer project Analysis Tools Lead
 - CPST/CNES Cryogenic CFD Benchmark Collaboration Lead
 - Cryogenic Fluid Management project Pressure Control Lead

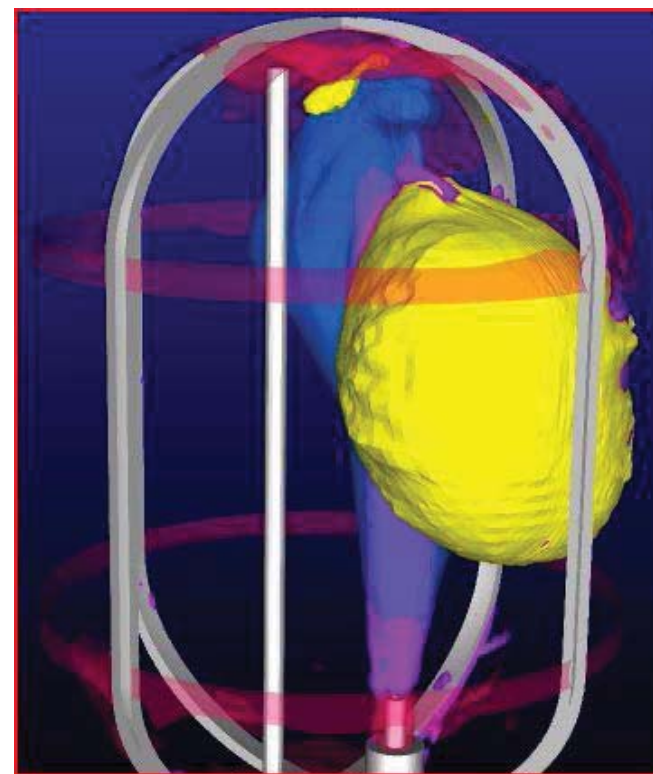



Logistics

- Egress
- Bathrooms
- Lunch time
- Breaks
- Charts



Course Objectives

- Introduce the student to basic concepts in cryogenic systems.
- Introduce the student to basic hardware used in cryogenic systems and what the function of the hardware is (i.e. why do you need that).
- Introduce the student to what may be experienced during testing of cryogenic systems and what types of measurements and instrumentation may be desired, needed, or required.
- Introduce the student to various methods of modeling and analysis of cryogenic systems including strengths and weaknesses of various tools.



INTRODUCTION



What Is Cryogenics?

Cryogenics is the study of physical phenomena at cold temperatures

- Cold = -150°C (123 K, -238°F)
- Etymology (Greek)
 - κρυος – Frost (Ice Cold)
 - γινομαι – To produce

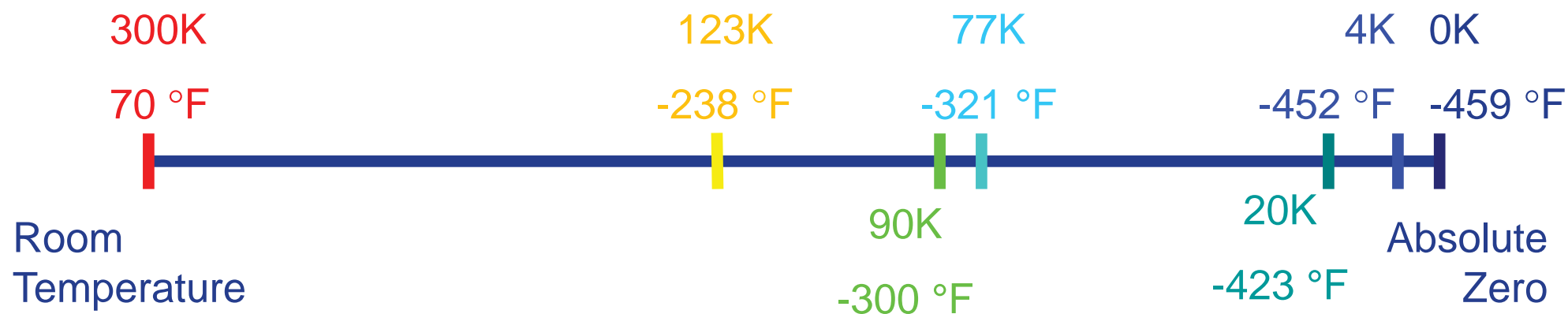

Why Use Cryogenics?

- High Energy Density
 - What would the Space Shuttle have looked like if it used ambient temperature gaseous hydrogen?
- Low Temperature





History of Cryogenics – The Politics

- In the 1870s, both US and Europe at peace
- Similar to boost in the arts came a boost in the sciences
 - Mostly self financed ventures
 - Had national bodies:
 - Royal Society – London
 - Academie des Sciences – Paris
 - Trained scientists had no jobs except teaching
- Governments began to see the possibilities that a scientific education could have



History of Cryogenics – The Need

- Supply of natural ice could not meet demand
 - Lager beer brewing required temps at ~ 5 C
 - Shipping of meat required long term storage
- Pollution in rivers also made natural ice hazardous
- People began making artificial ice
- 1877 – first successful shipment of frozen meat from Marseilles to Buenos Aires
- 1877 – Bell and Coleman (Scottish) patent air-cycle refrigerator (use air as working fluid instead of ammonia or sulfur dioxide)



History of Cryogenics – in Infancy

- 1877 – both Cailletet and Pictet independently liquefy oxygen (first “permanent” gas to be liquefied)
 - Could not be liquefied by pressure at ambient temperature
 - Pictet used cascade refrigeration system with sulphur dioxide and liquid carbon dioxide heat exchangers prior to a isenthalpic expansion across a valve
- Neither could capture the liquid



History of Cryogenics – The Researchers

- Onnes – University of Leiden (1882 – 1930s)
 - Started the low temperature physics laboratory
 - Self published work
 - Open door policy
 - Worked with van der Waals
- Dewar – Cambridge (1875 – 1923)
 - Gave “Friday evening discourses” at Royal Institute
 - Isolated himself from teaching and industry
 - Developed “silvering” of glass containers to lower heat load
 - Lack of good enough glass blowers led to metallic double walled vessels



History of Cryogenics – The Engineers

- 1895
 - Hampson (England) and Linde (Germany) independently patent air liquefiers
 - British (Brins) Oxygen Company bought Hampson's patent
 - Constructed & Sold air & hydrogen liquefiers
 - Linde started his own company
- 1897 – Tripler (US)
 - Use liquid air to drive air expansion engines
 - Had 25 liter/hr system
 - Believed he had found a perpetual motion machine
 - Soured US on cryogenics due to his (obviously wrong) claims
- 1902 – Claude (French)
 - Developed the piston expander
 - Started Air Liquide



History of Cryogenics - Highlights

- 1877 (Cailletet & Pictet) – Oxygen
- 1883 (Olzewski & Wroblewski) – Nitrogen, Carbon Monoxide
- 1898 (Dewar) – Hydrogen
- 1908 (Onnes) – Helium
- 1911 (Onnes) – Superconductivity of copper

History of cryogenic fluid propulsion systems in space flight

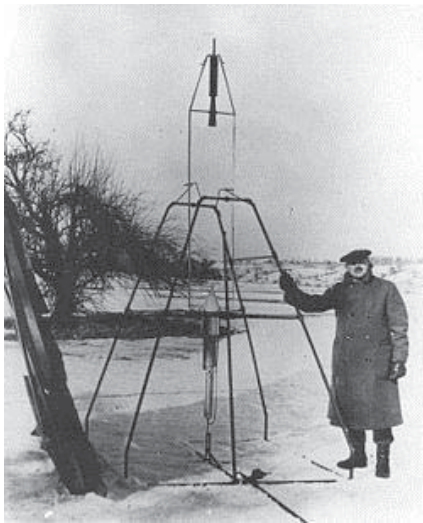

1926

Seconds



1967

Hours



1981

Weeks

Longer missions require more sophisticated cryogenic fluid management technologies



2030

Months - Years?



Thermodynamics Intro

Cryogenics is all about Thermodynamics and Heat Transfer

Cryogenic liquids are generally a two phase fluid

- This means both liquid and vapor/gas present
- Quality is the term used to define the vapor to liquid



Phase Diagram - PT

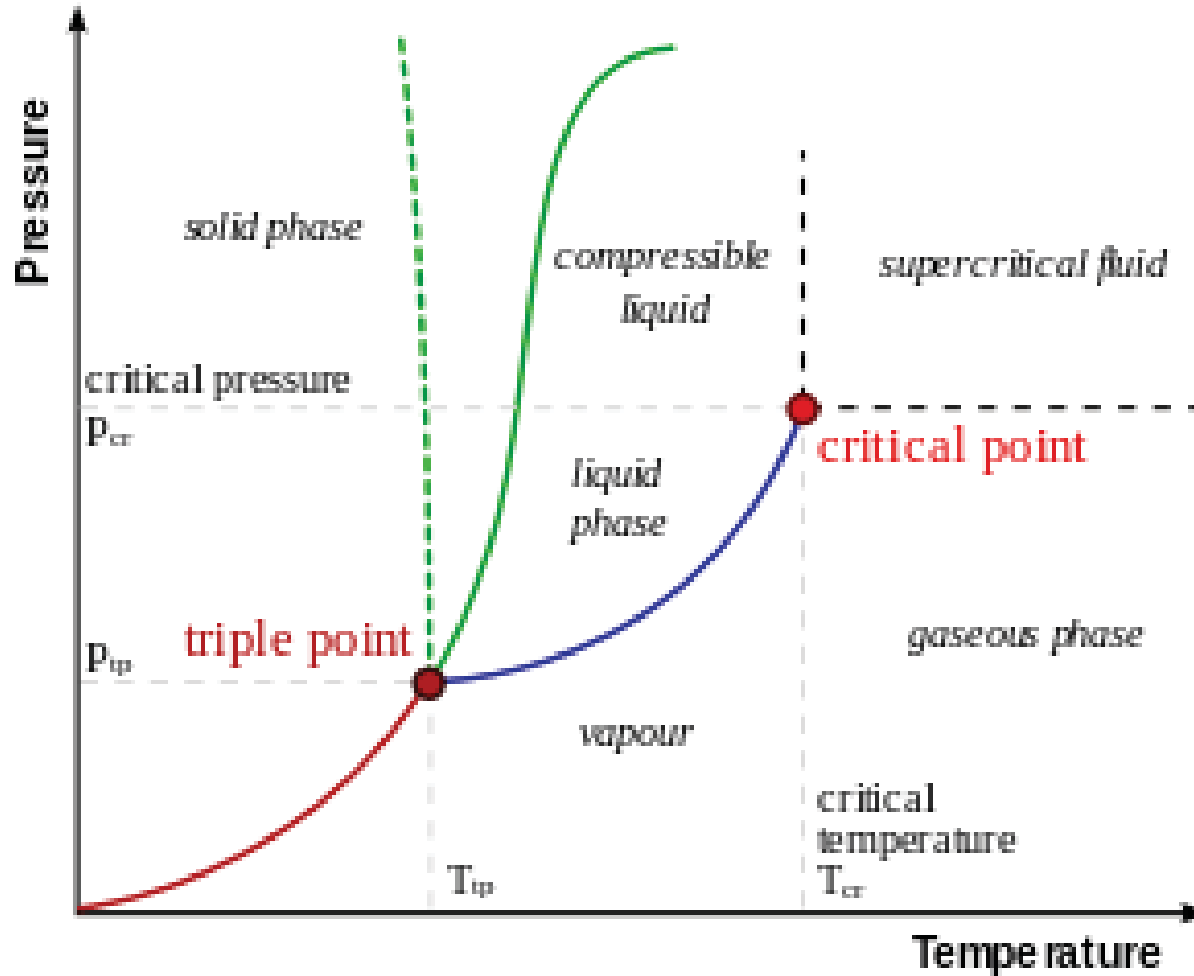



Phase Diagram - PV

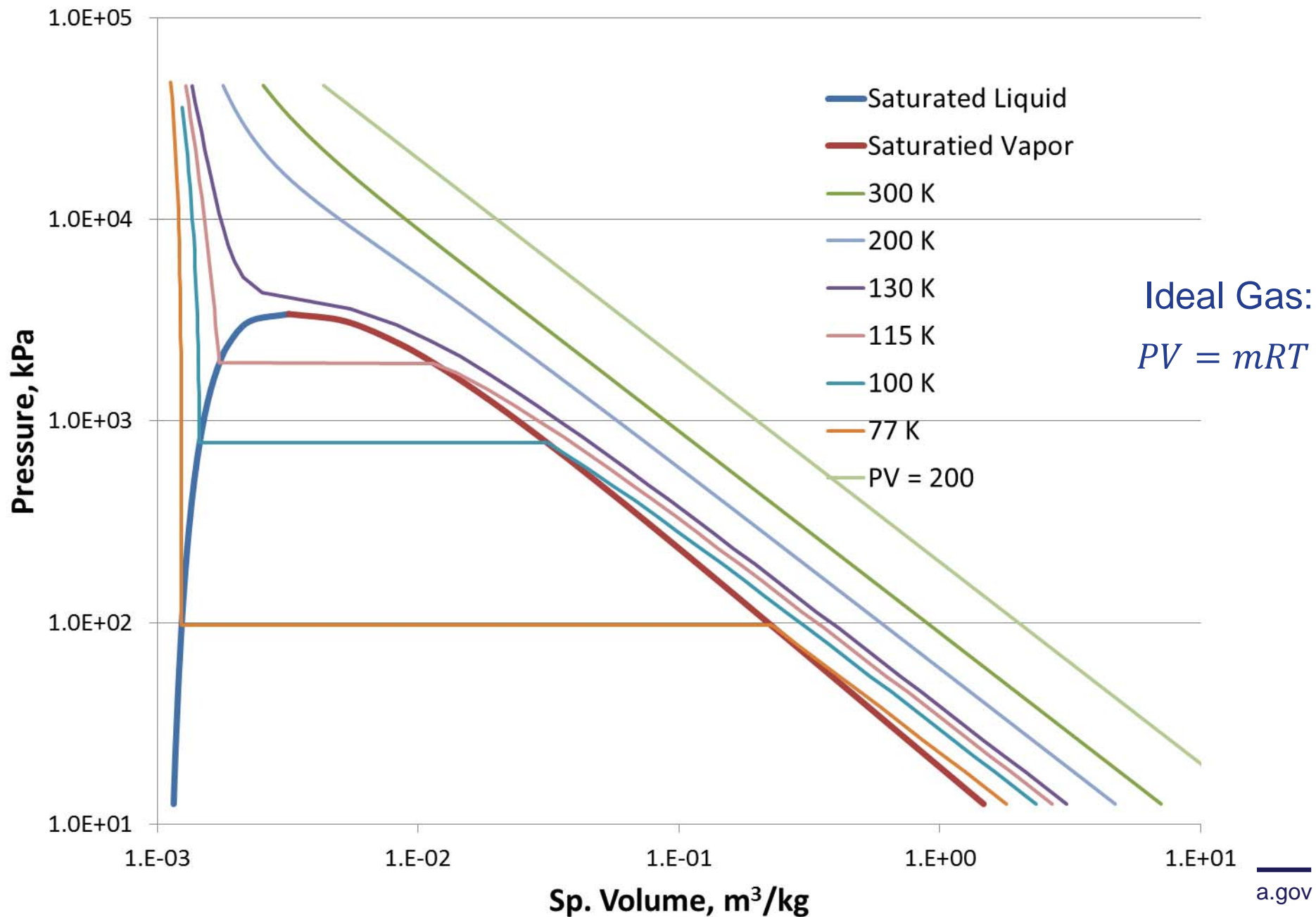



Phase Diagram – HS

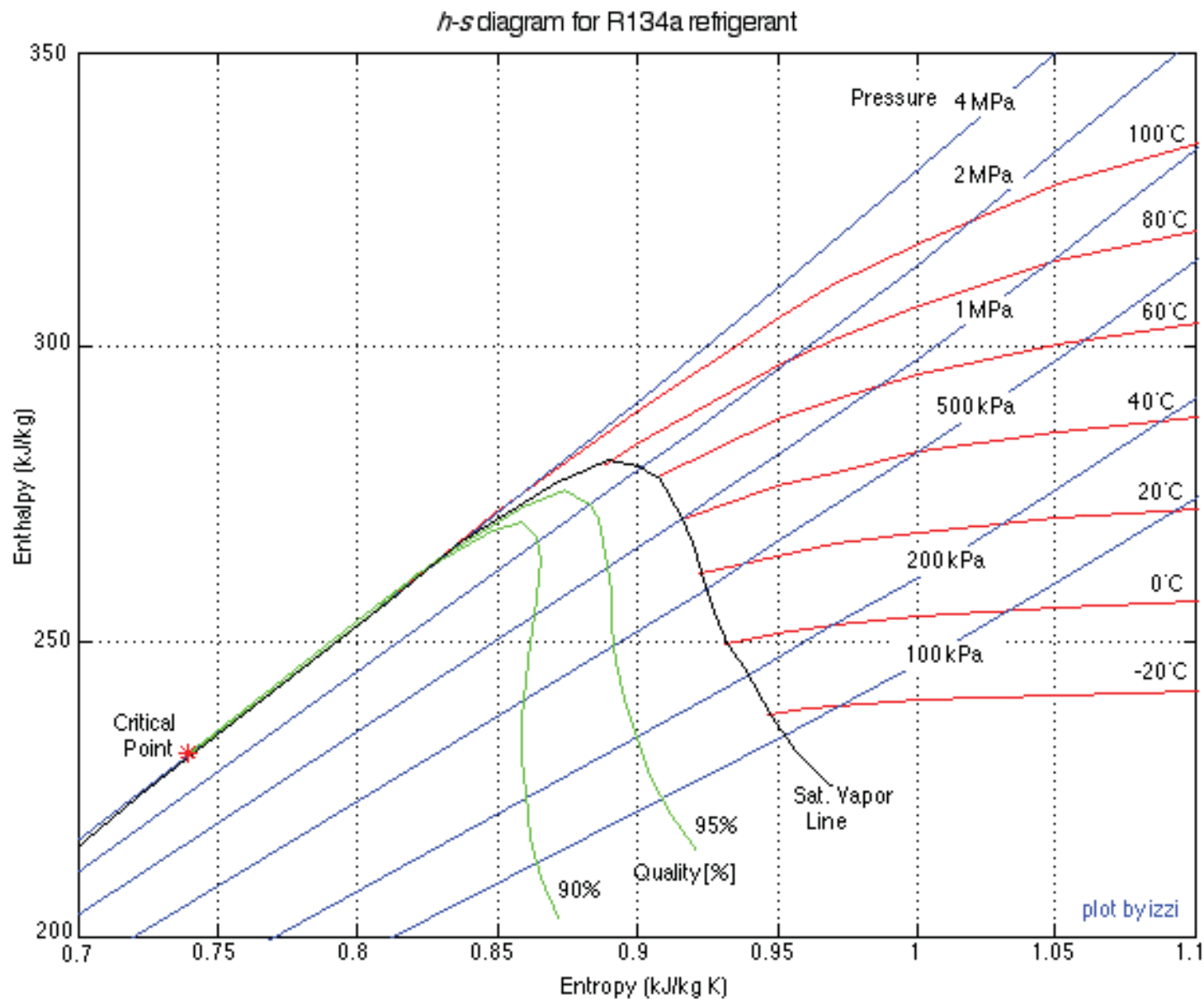



Conduction Heat Transfer

$$\dot{Q} = - \int \frac{A(x)}{dx} \int k(T) dT$$

- A: Cross Sectional Area (as a function of length)
- dx: differential length
- T: Temperature
- k(T): Thermal Conductivity (as a function of Temperature)
- S, Shape factor $S = \int \frac{A(x)}{dx}$
 - Flat plate: $S = \frac{A}{x}$
 - Hollow Cylinder: $S = \frac{(r_o - r_i)}{\ln(r_o/r_i)}$
 - Hollow Sphere: $S = \frac{4\pi R_o R_i}{(R_o - R_i)}$



Thermal Conductivity

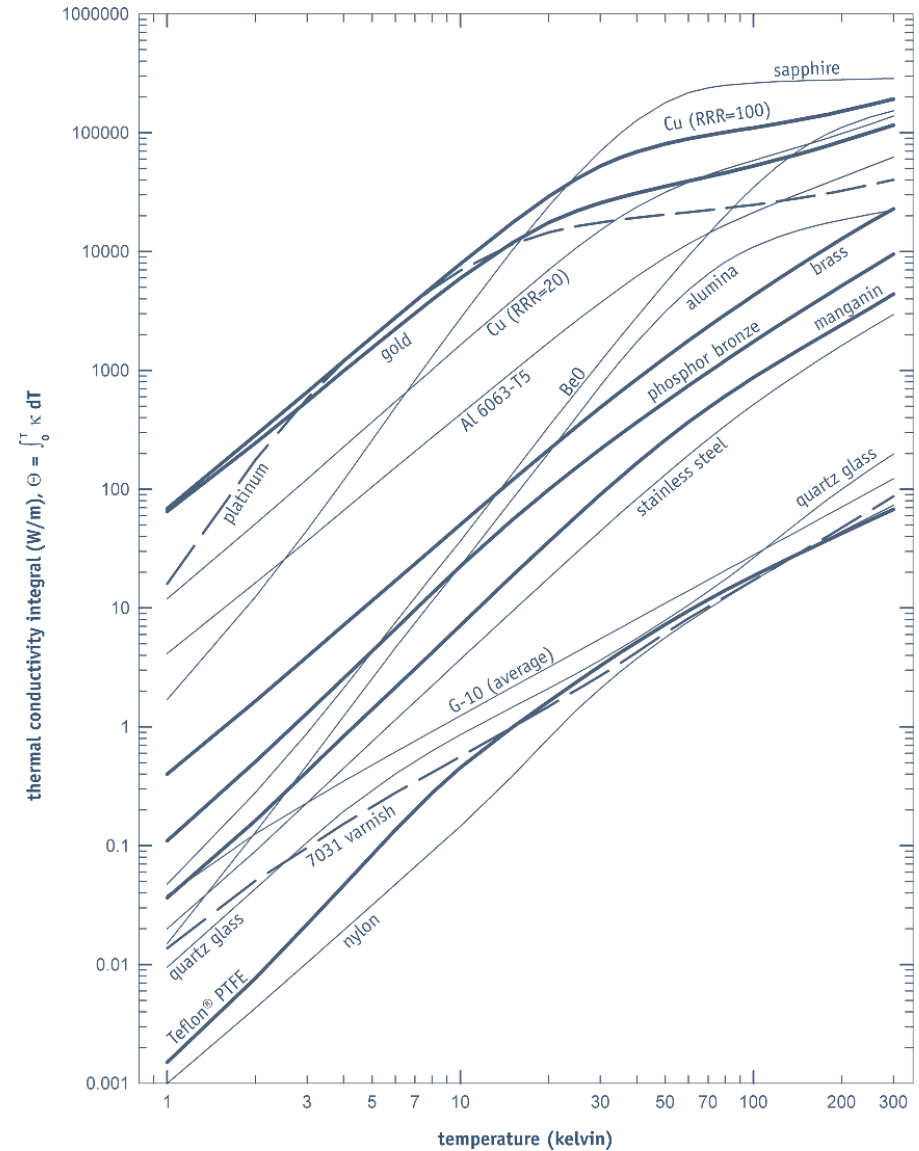
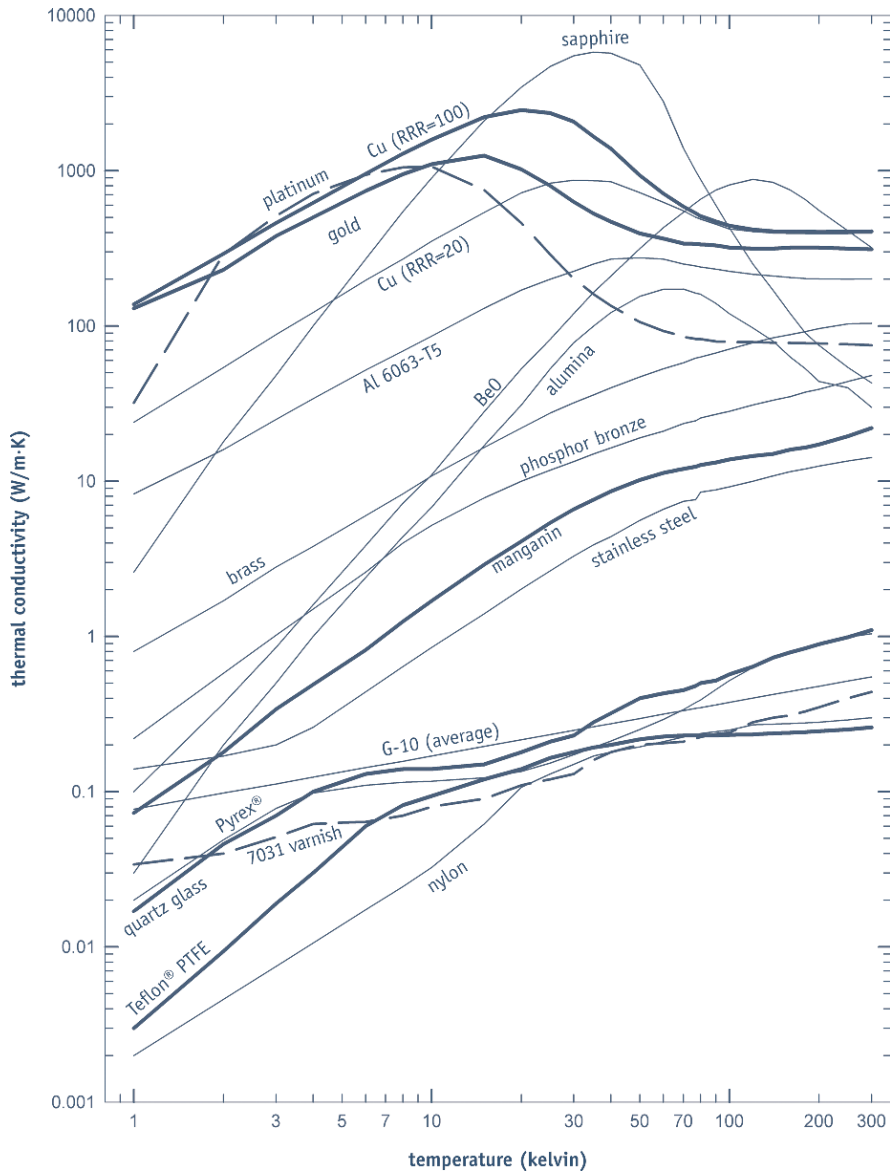

Lakeshore Cryotronics Catalog



Convection Heat Transfer

- Newton's Law of Cooling

$$\dot{Q} = -hA(T_h - T_c)$$

- h, Convection heat transfer coefficient

- Nusselt Number $Nu_L = \frac{hL}{k_f}$

- Reynolds Number (forced convection) $Re_L = \frac{\rho VL}{\mu}$

- Rayleigh Number (natural convection)

$$Ra_L = \frac{\rho g \beta \Delta T L^3}{\mu \alpha}$$

Beta is Thermal Expansion Coefficient, $1/T$ for ideal gasses



Radiation Heat Transfer

$$\dot{Q} = A\varepsilon\sigma(T_h^4 - T_c^4)$$

- Sigma, σ , is Stefan-Boltzman Constant, $5.67 \cdot 10^{-8}$ W/m²/K⁴
- Emissivity, ε , a function of both surfaces

$$\frac{1}{\varepsilon} = \frac{1}{\varepsilon_h} + \frac{1}{\varepsilon_c} - 1 = \frac{2 - \varepsilon}{\varepsilon}$$

- A is a function of various view factors between surfaces

<http://www.engr.uky.edu/rtl/Catalog/tablecon.html>



BASIC SAFETY



Asphyxiation

- Occurs when a gas (in this case nitrogen) replaces oxygen in the atmosphere
- According to US Chemical Safety and Hazard Investigation Board, there are approximately 8 deaths per year due to nitrogen asphyxiation
 - Most are not due to cryogenic handling
 - 5 more injuries per year
 - Generally happens in a “confined space”
- OSHA defines a hazardous atmosphere as being less than 19.5% oxygen
 - Time to get out
 - Maximum oxygen content: 23.5%



Effects of Lowered Oxygen Concentration

Effects of Oxygen Deficiency on the Human Body

Atmospheric Oxygen Concentration (%)	Possible Results
20.9	Normal
19.0	Some unnoticeable adverse physiological effects
16.0	Increased pulse and breathing rate, impaired thinking and attention, reduced coordination
14.0	Abnormal fatigue upon exertion, emotional upset, faulty coordination, poor judgment
12.5	Very poor judgment and coordination, impaired respiration that may cause permanent heart damage, nausea, and vomiting
< 10	Inability to move, loss of consciousness, convulsions, death

SOURCE: Compressed Gas Association, 2001.

Table from U.S. Chemical and Safety Hazard Investigation Board Safety Bulletin, 6/11/2003



Altitude Effects of Oxygen

Equivalent Percent O2	Pressure (psia)	Effective Altitude (ft)
20.9	14.7	0
19	13.7	2000
18	12.7	4000
16	11.3	7000
14	9.8	10,500
12.5	8.8	14,000
10	7.0	19,000

**Note: Mountain climbers have climbed Mt. Everest (~29,000 ft) with out supplemental O2
The death zone is considered 26,000 ft**



Low Temperature Skin Exposure

- Leidenfrost effect allows for 4-11 seconds of immersion.
 - As measured by thermocouples as near to the surface as possible
- Glove increases time scales for immersion
 - Long term can cause more damage if glove removed improperly
- A sleeved arm was found to chill down quicker, and suffer a larger area of freezing, than a bare arm with direct LN2 flow.
- Splash testing
 - Froze low thermal mass locations for brief periods
 - Recovered with little to no damage to ballistic gel
 - Does not imply that no tissue damage would occur on a real hand

PPE – Wear It All





Over Pressure

- Liquid nitrogen expands by a factor of 700 between a cryogenic liquid and a room temperature gas
 - The first ~200x expansion is in the phase change
 - The rate of phase change of a fluid is proportional to the energy input into it

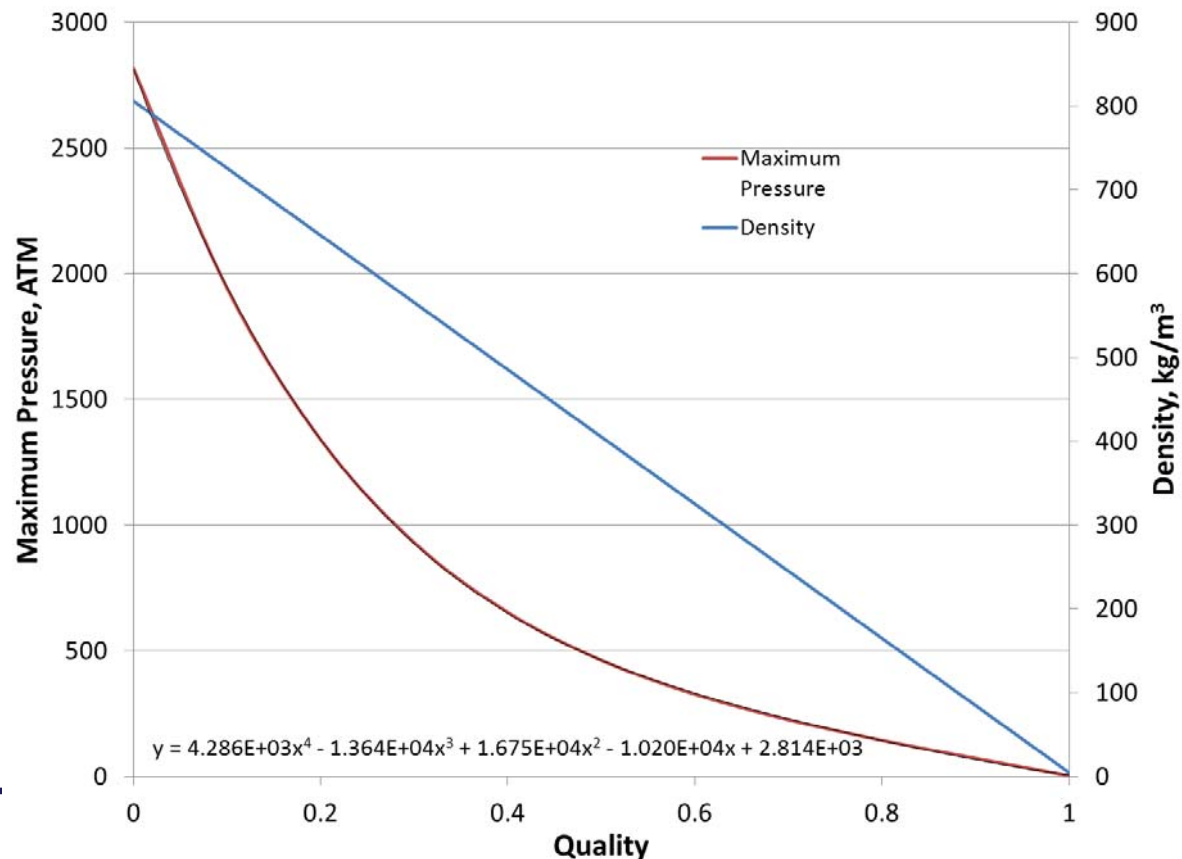

Pressure Relief Devices

- Relief Valve
 - Set at 90 to 105 % of MAWP
 - Usually set at 105%
- Burst Disk
 - Set at 110% of MAWP
 - For allowing high flow in case RV doesn't have large enough flow rate

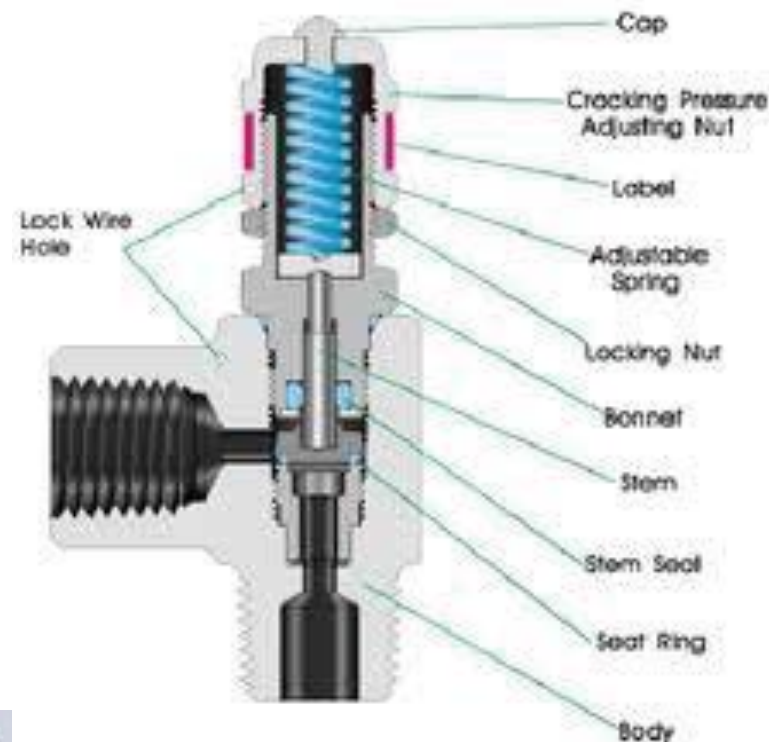

Note: MAWP is not design pressure, RVs should be set at or below the design pressure



Over Pressure Table

Quality	0	0.1	0.2	0.3	0.4	0.5	0.6	0.7	0.8	0.9	1
Nitrogen	2816.6	1942.5	1340.0	930.6	653.3	462.7	327.4	225.9	144.1	72.4	4.0
Helium	1141.1	1001.5	871.5	750.4	637.7	532.7	434.9	343.9	259.0	179.8	105.7
Hydrogen	1869.2	1525.5	1234.5	988.3	779.6	602.0	450.2	319.2	205.3	105.2	16.0
Methane	2289.0	1444.3	912.9	590.5	398.5	282.8	208.3	154.0	107.0	58.9	2.7
Oxygen	2750.0		1511.6	1014.4	697.8	491.8	351.3	247.8	162.9	84.5	3.3
Argon	3250.0	2169.4	1451.3	983.5	680.8	481.9	345.3	244.0	160.5	83.1	3.5

Ending condition: 300 K vapor
 Pressure in Atmospheres
 Formulated using RefPROP

Thermal Expansion/Contraction





Typical Thermal Expansion Values

Material	$\Delta L/L$ 293 K to 77 K	$\Delta L/L$ 293 K to 20 K	$\Delta L/L$ 293 K to 4 K
Titanium (pure)	-0.143		-0.151
Copper	-0.302		-0.324
Aluminum (6061)	-0.389	-0.415	-0.415
Titanium 6Al-4V	-0.16	-0.17	-0.17
SST 304	-0.28	-0.30	-0.30
SST 316	-0.28	-0.30	-0.30
Invar	-0.04	-0.04	-0.04
G-10CR (warp)	-0.21	-0.24	-0.24
G-10CR(normal)	-0.64	-0.71	-0.71
Nylon	-1.26	-1.38	-1.39
Teflon	-1.94	-2.12	-2.14

Note: All values in % expansion, so -.143 is .143% contraction

Data from Ekin, J.W. *Experimental Techniques for Low-Temperature Measurements* & NIST



HARDWARE

Cryogenic Fluid Management Technologies

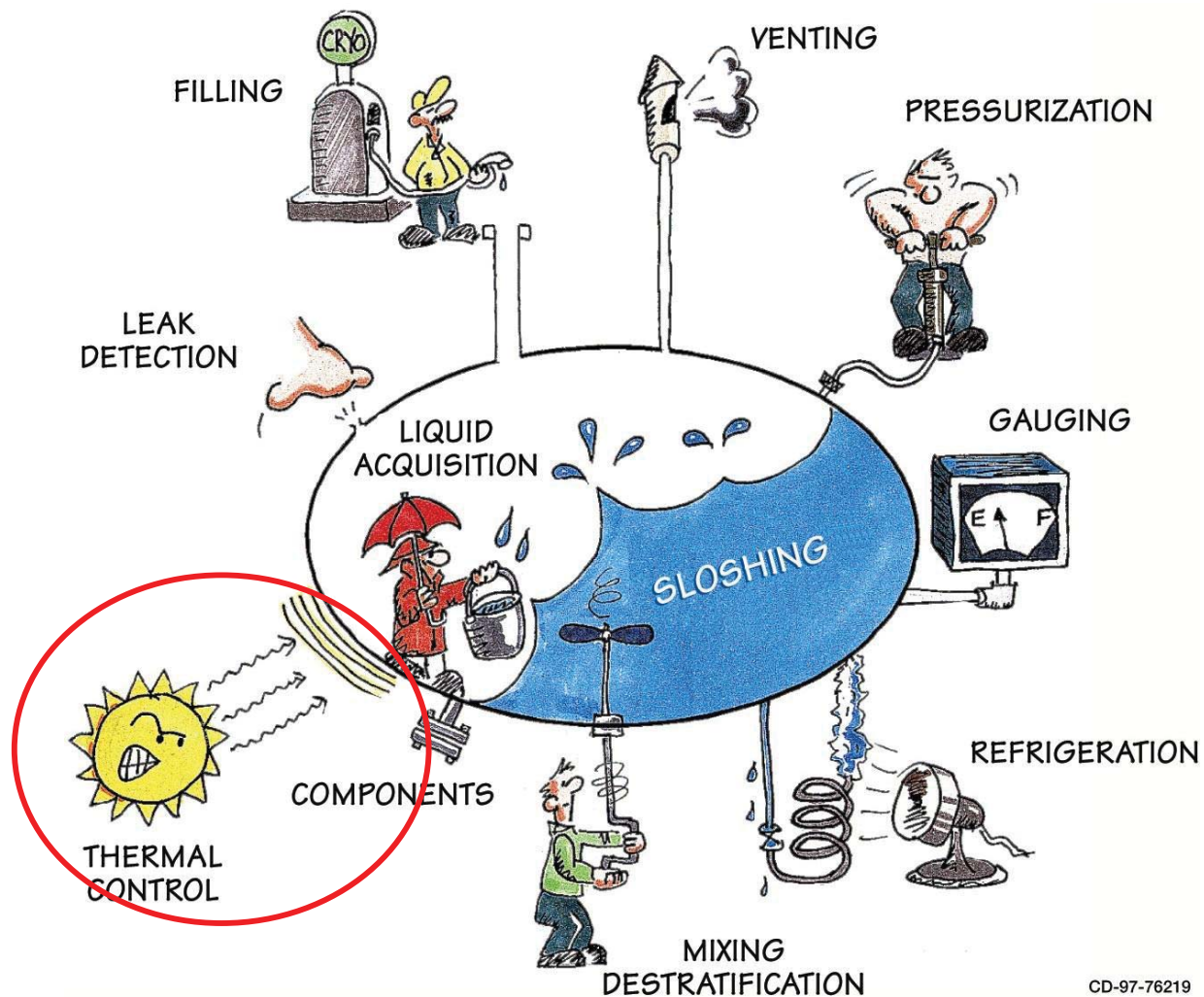

Insulation

- MLI
- Foam
- Aerogel
- Fiberglass
- Loose Fills





Insulation

- Environment is everything
- Works as a function of ΔT & T_{mean}
 - Material properties change with both
 - Thermal conductivity as a function of temperature ($\lambda(T)$) does not work in real life
- A working tool box
 - Different materials work in different situations
 - No global solution

Apparent thermal conductivity data (k-values) for different cryogenic insulation materials (293 K / 77 K)

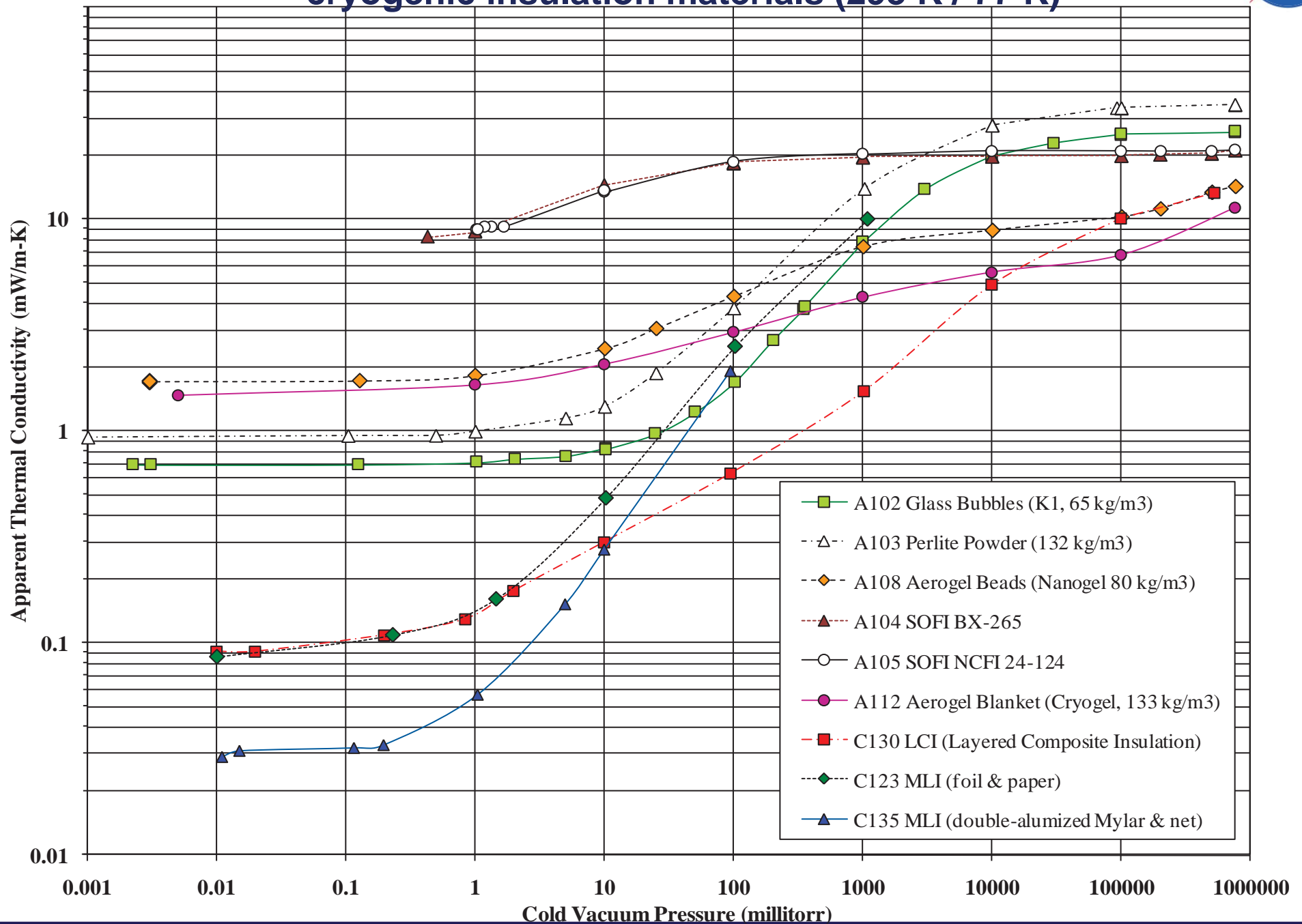

Foams

- Generally have relatively good thermal performance
 - 30 – 40 mW/m/K at ambient pressure and room temperature
 - Don't gain much in vacuum
 - Essentially a bunch of cells that are filled with a “blowing agent” (i.e. freon) that dominates the conductivity
 - Density $\sim 10 - 30 \text{ kg/m}^3$
- Closed Cell = 90% closed cell
 - Will change with aging
- Can be cheap (buy “Great Stuff” at Home Depot)
- Easy to apply [incorrectly]



Foams

- Applied via spray process
- Issues:
 - Cracking
 - Divoting
 - Icing
 - Moisture uptake
 - Degrade in UV light (i.e. outside)
 - Not strong
 - Aging



Aerogels

- Lightest solid known
 - Usable density $\sim 80 - 120 \text{ kg/m}^3$
 - Have been made much lower
- Lowest conductivity solid known
 - Nanoporous
 - Useful forms $\sim 15 \text{ mW/m/K}$ at STP
- Multiple forms
 - Beads/Granules
 - Blankets
 - Films
- Can be made hydrophobic
- Used for thermal control of satellites when MLI not required





Aerogels

- Made via supercritical drying process
- Issues:
 - Outgassing
 - Sorption
 - Attachment
 - Cost (getting better)

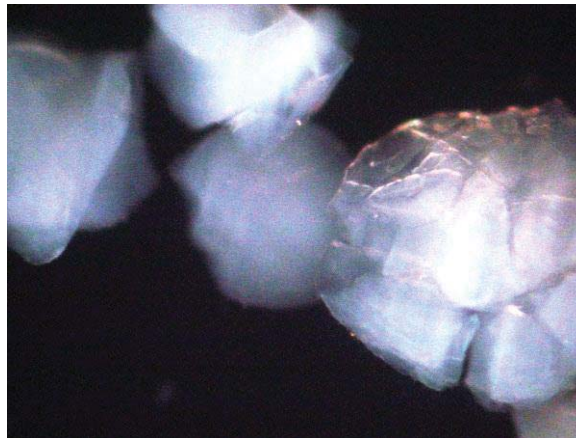
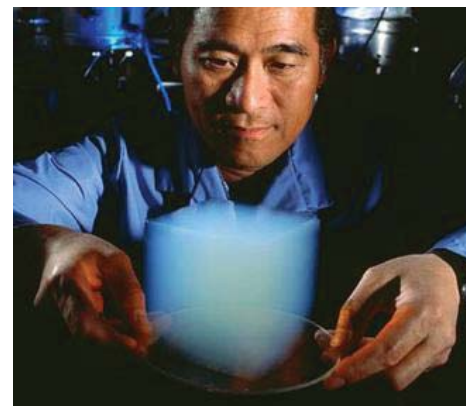

Loose Fills

- Multiple different types
 - Perlite
 - Glass bubbles
 - Aerogel beads/granules
 - Dirt
- Large double wall tanks (dewars)
- Where readily available

Martian
Regolith

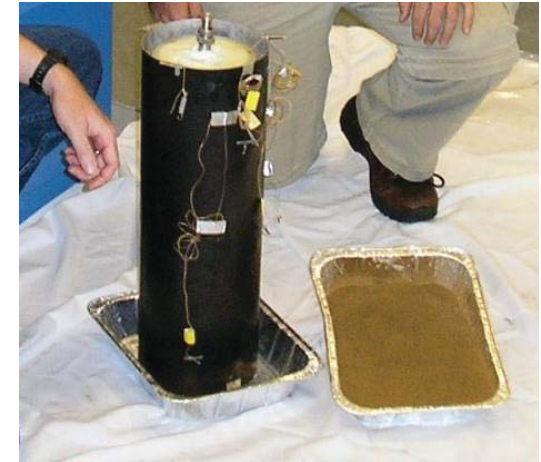

Glass bubbles

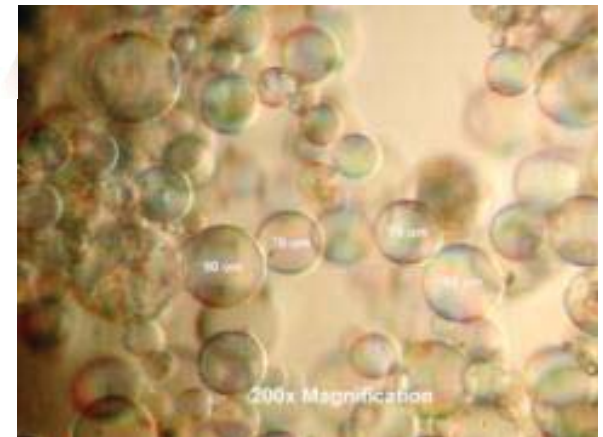



Fiberglass & Others



Cryo-Lite
Lydall





Variables in MLI

- Material Types
 - We will always assume DAM and Dacron net within this presentation
 - Perforations – they hurt performance, help pumping?
 - Emissivity of reflectors
- Layer Density (also whether constant or variable)
- Thickness (number of layers)
- Interstitial Pressure (and therefore interlayer pressure)
 - Assumed to be 10^{-6} torr in data presented here
 - Assume that there is no pressure gradients within the MLI
 - Interstitial gas (helium, hydrogen, nitrogen, carbon dioxide)
- Warm Boundary Temperature (WBT)
- Cold Boundary Temperature (CBT)
- Application Variable (how applied)
 - Wrapping procedure
 - Connections/penetrations/support
 - Tank geometries

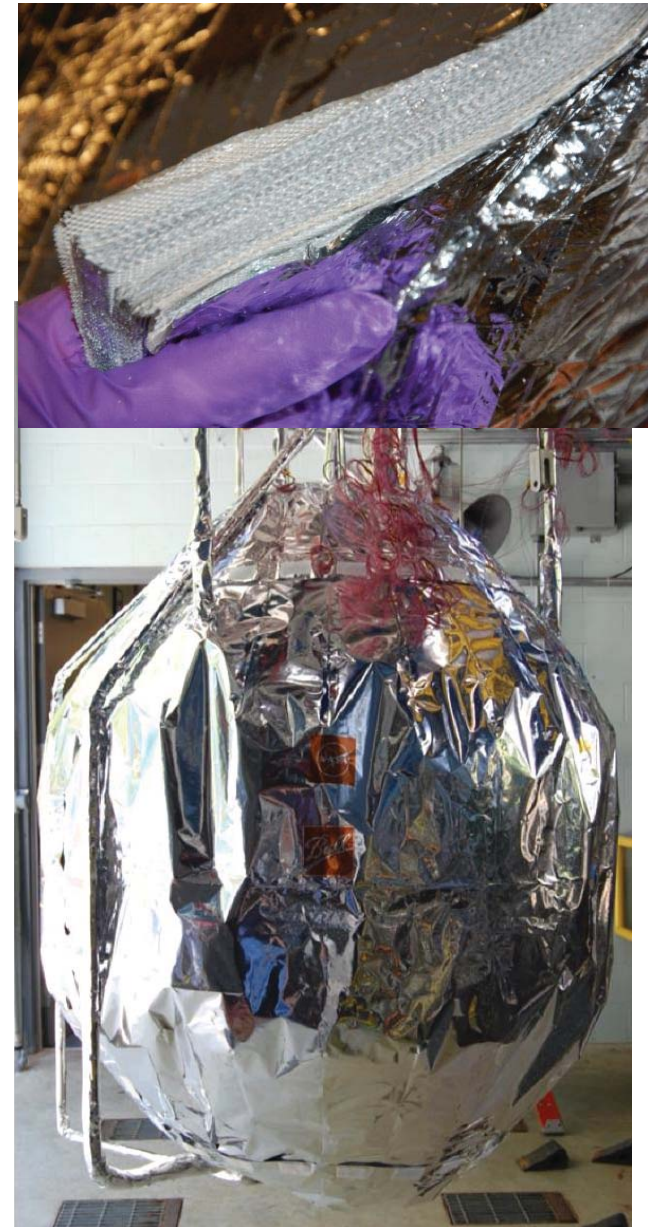



MLI Heat Transfer

- Combination of all three forms of heat transfer

$$q'' = \frac{C_s * \bar{N}^{2.63} (T_h - T_c) * (T_h + T_c)}{2 * (N + 1)} + \frac{C_R * \varepsilon * (T_h^{4.67} - T_c^{4.67})}{N} + \frac{C_G * P * (T_h^{0.52} - T_c^{0.52})}{N}$$

$$q'' = \frac{\sigma (T_h^4 - T_c^4)}{\left(\frac{1}{\varepsilon_h} + \frac{1}{\varepsilon_c} - 1 \right)} + C_1 P \alpha (T_h - T_c) + C_2 f k \frac{(T_h - T_c)}{\Delta x}$$

- Assume 1-D heat transfer (anisotropic material properties can lead to huge headaches if not 1-D)
- Historically, deviations from these equations accounted for by what is called a Scale Factor, just a multiplier thrown on end



Analysis – effect of number of layers

Variation of heat flux q with the number of layers

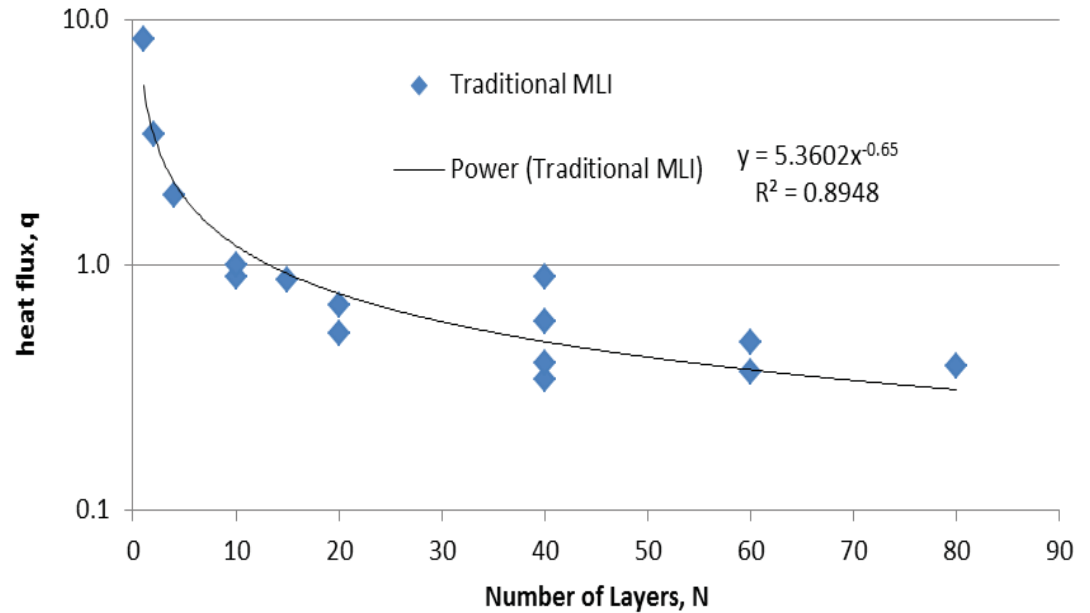

Variation of the quantity $q \cdot N$ with the number of layers

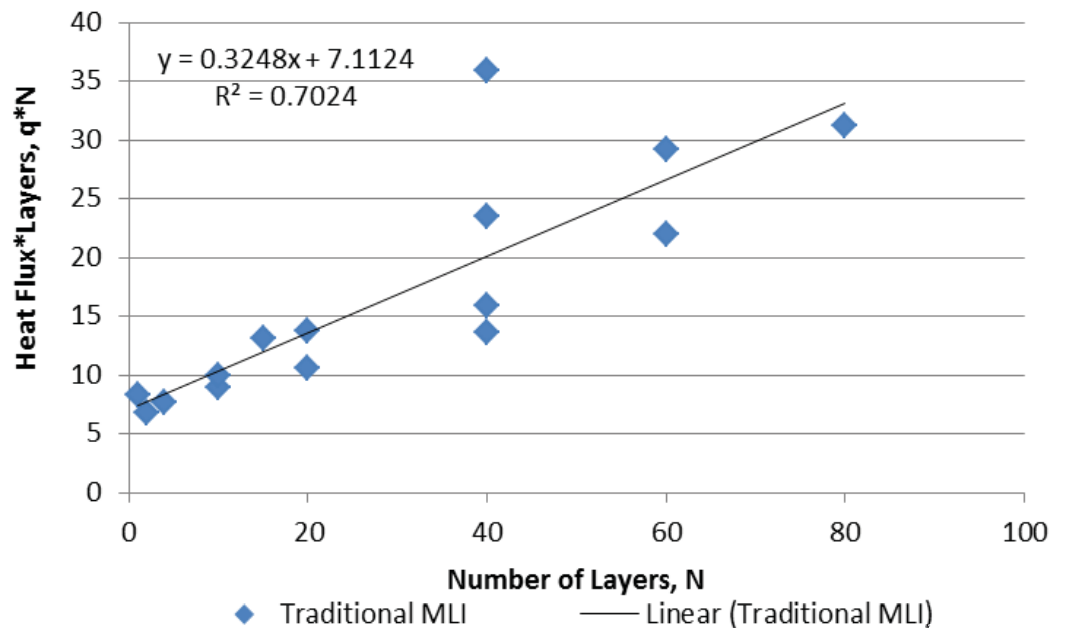



Analysis – comparison of data to thermal

Variation of the Scale Factor with the number of layers

$$Scale\ Factor = \frac{Q_{MLI,test}}{Q_{MLI,predict}}$$

Variation of the Scale Factor with the layer density

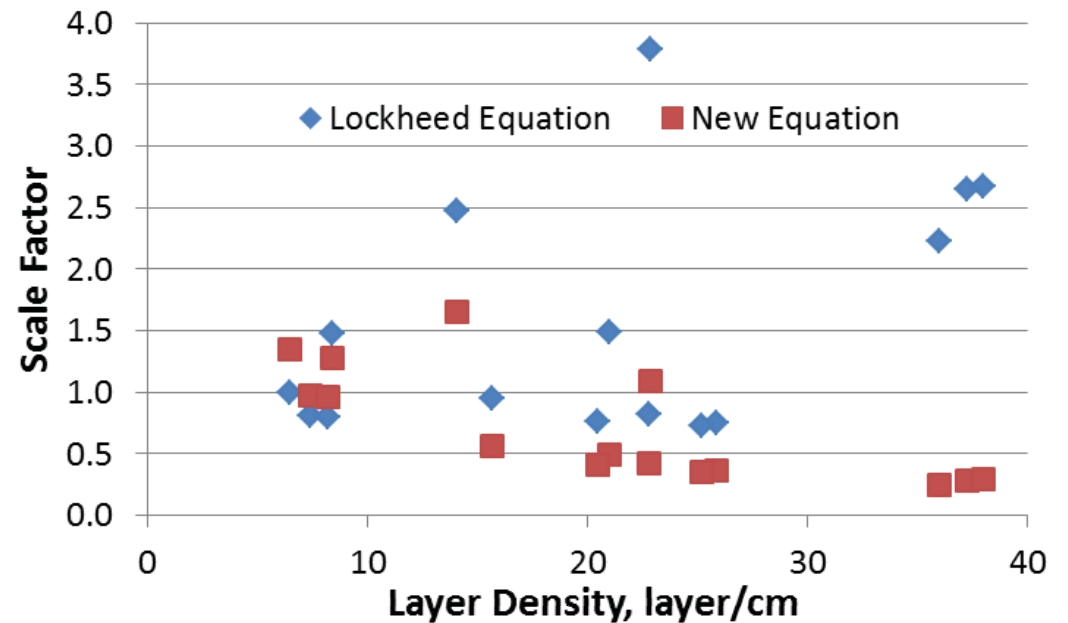
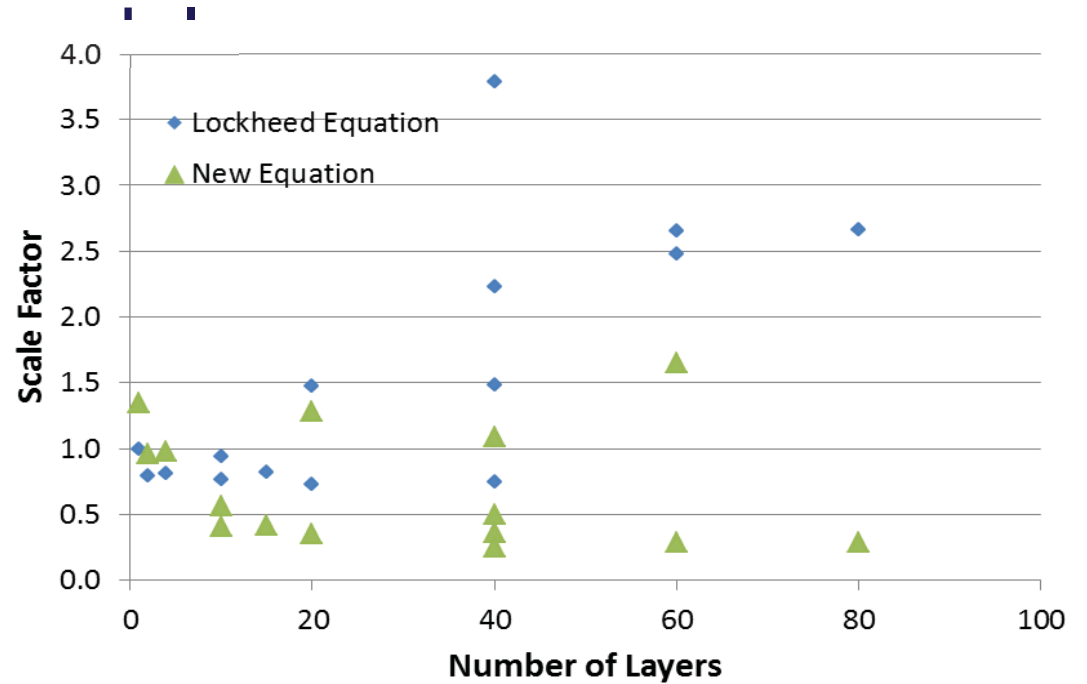

Cryogenic Fluid Management Technologies

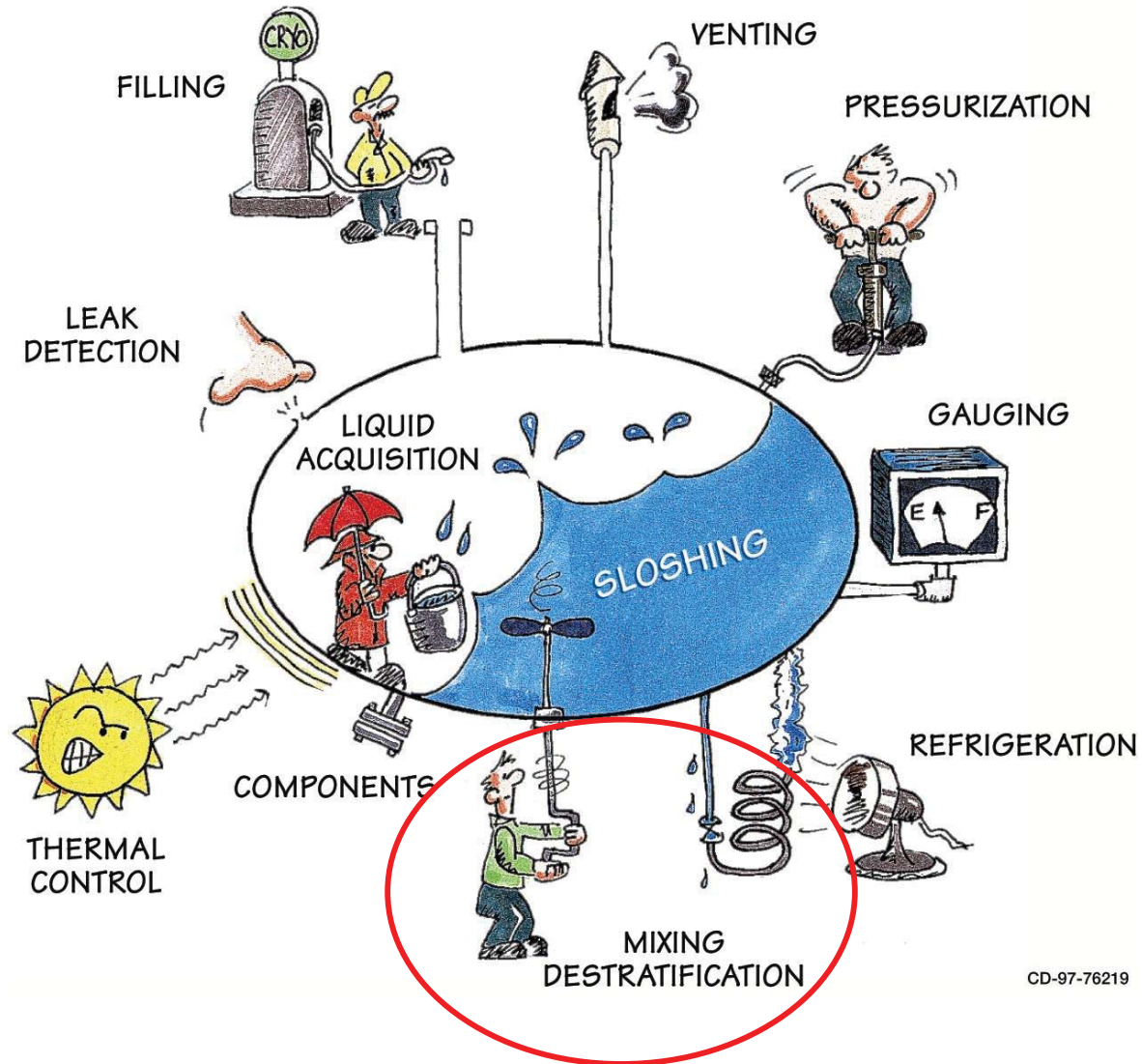

CD-97-76219



Vapor Stratification – Tank Open

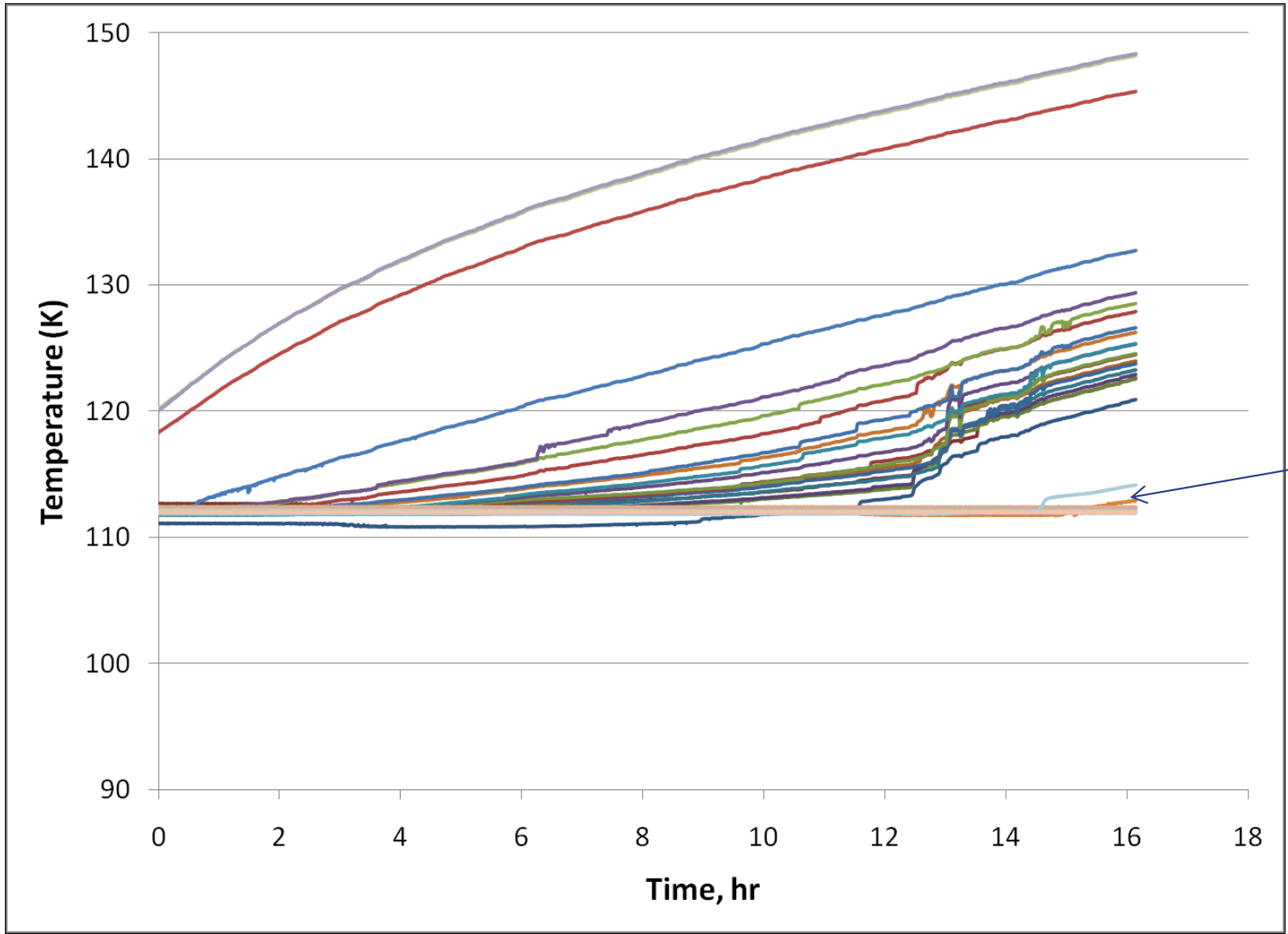

Liquid-vapor Interface



Liquid Stratification – Tank Closed

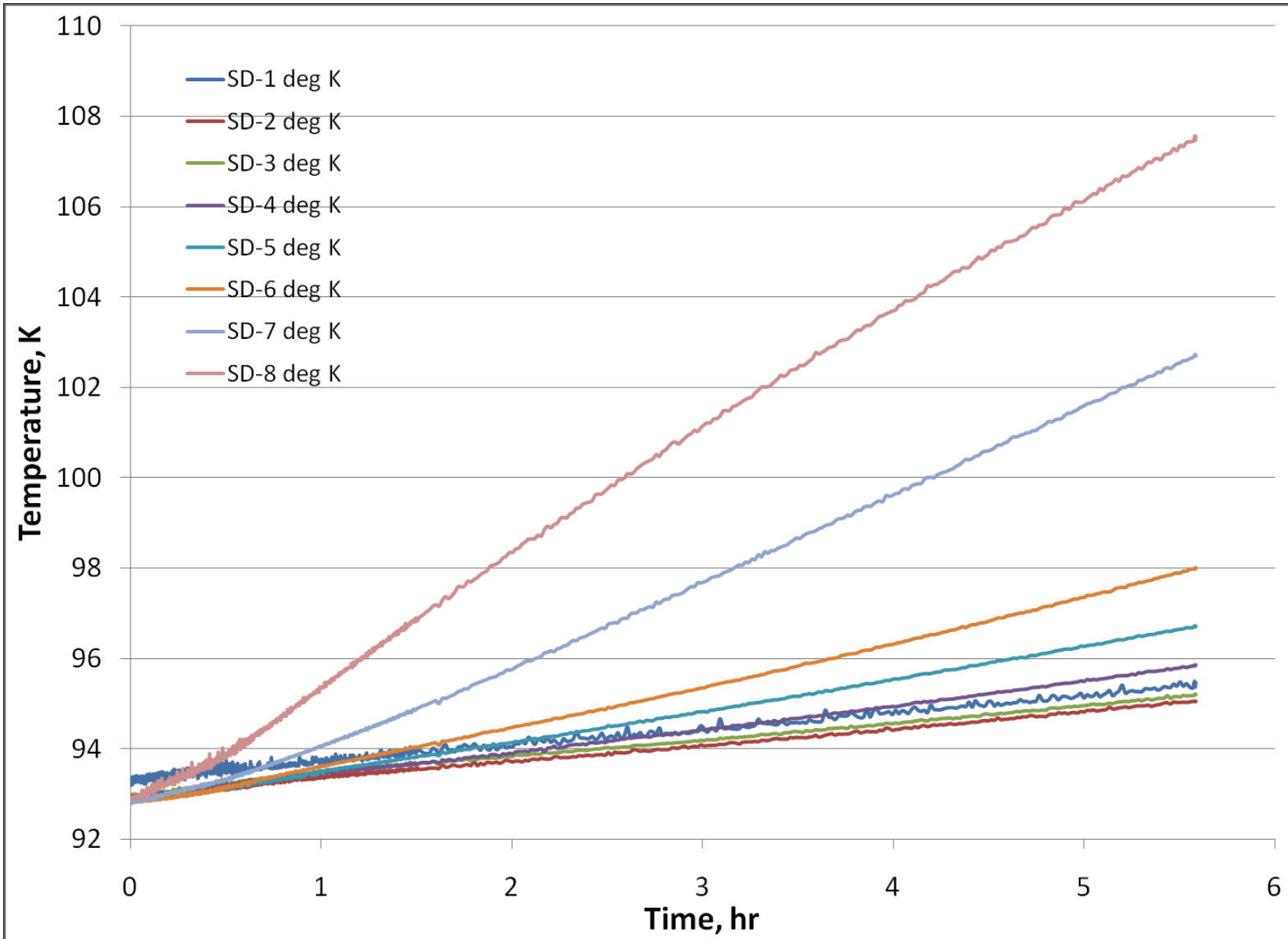



Mixed vs. Unmixed

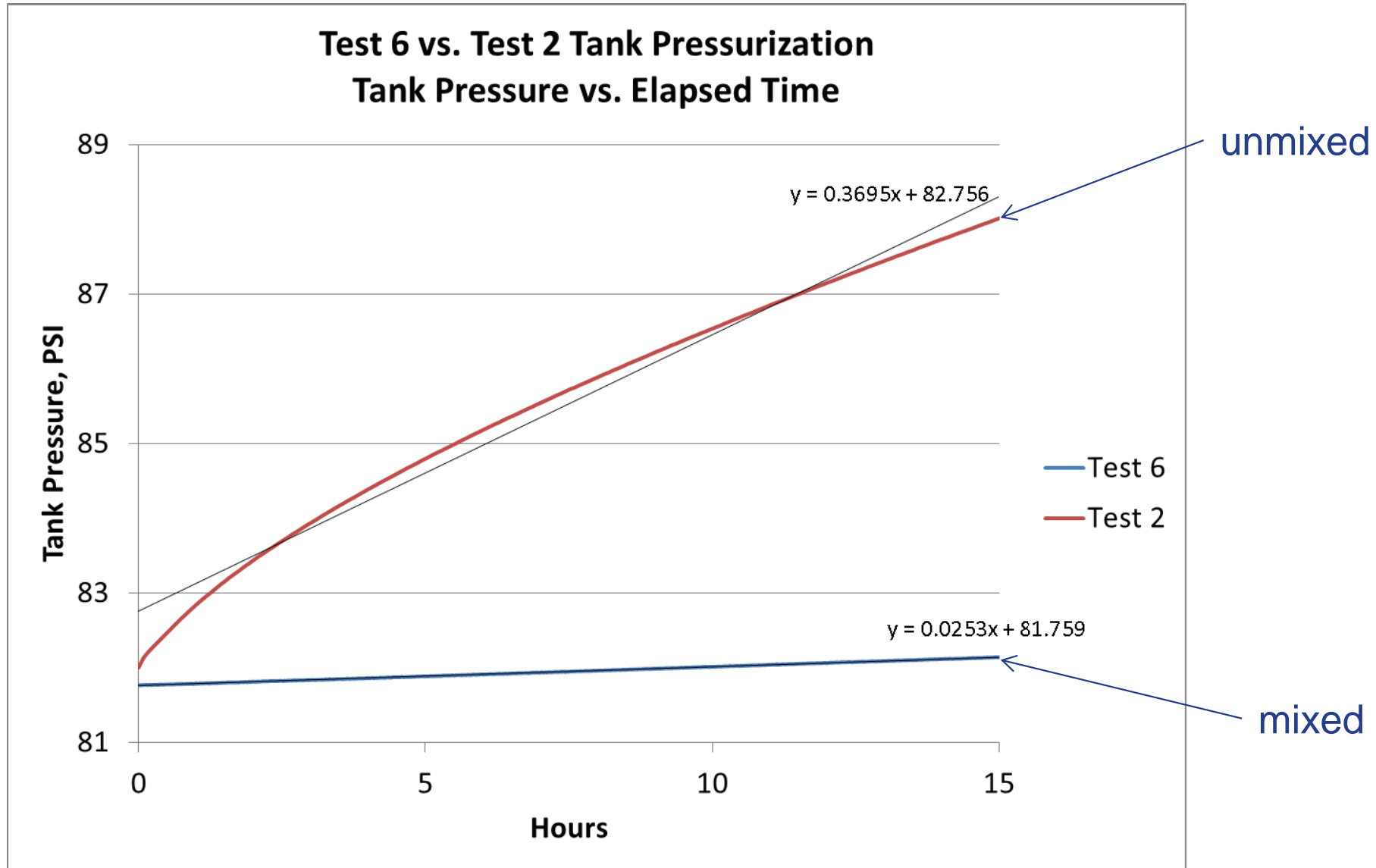

Destratification

- Mixing Pumps
 - Integrated with TVS system
- Tube-on-Tank HX
 - Integrated with cryocooler
- Natural Convection

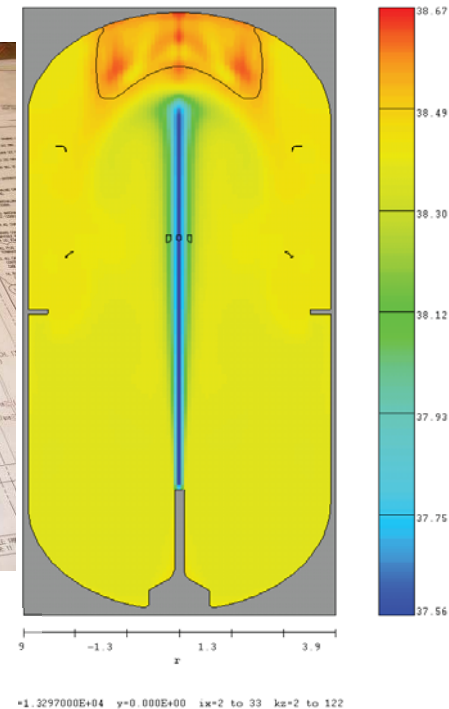

Cryogenic Fluid Management Technologies

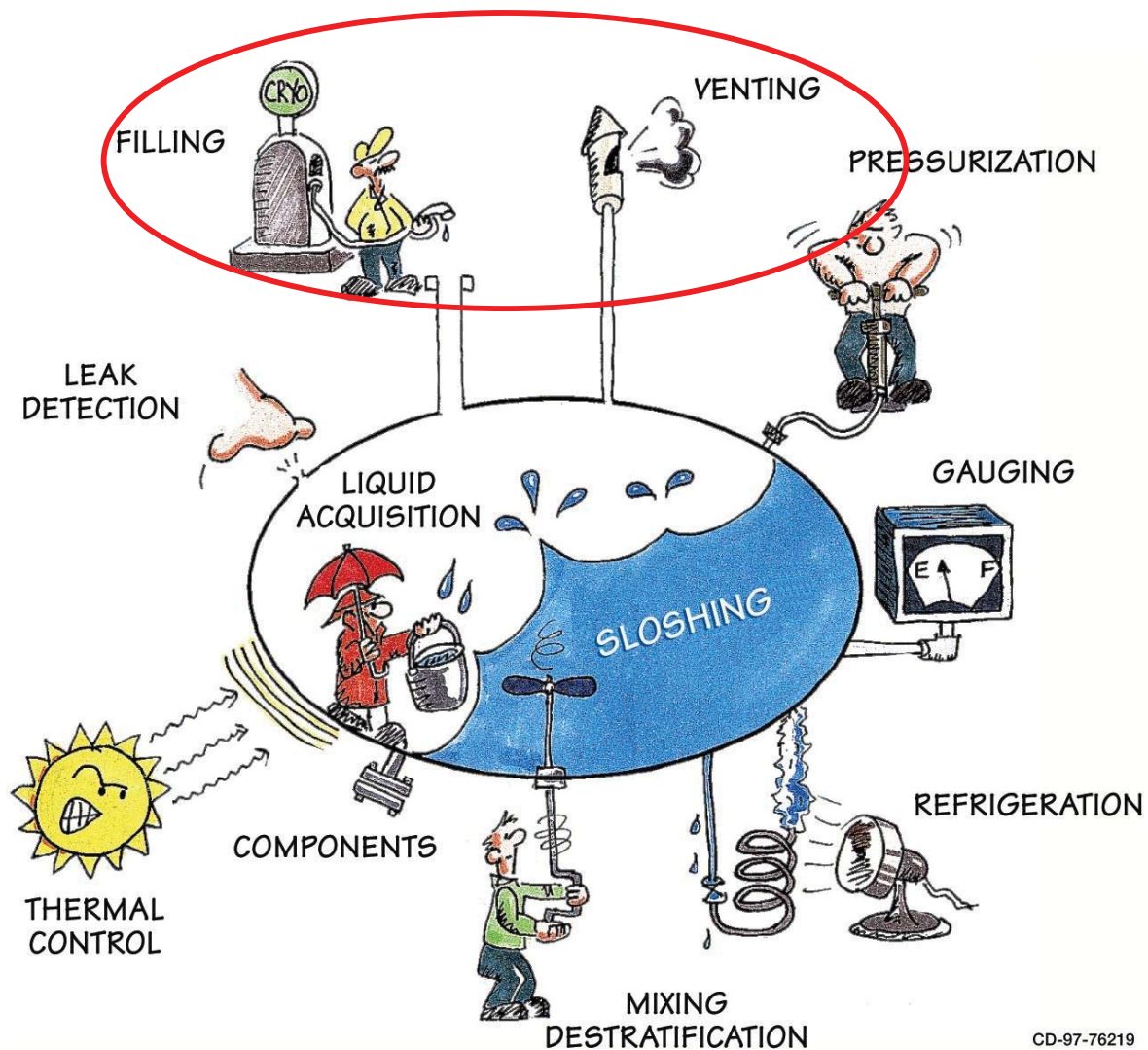

CD-97-76219



Filling and Venting

- Concept of Vapor Lock
- Back Pressure
- Flaring
- TVS



Vapor Lock

There is a flow rate at which liquid will not make it into your tank: based on fill line or transfer line heat load, pressure drop, & geometry,

- Steady state heat load overcomes latent and sensible heat of mass flow through the system
- Not enough pressure at source to push liquid through the piping
 - Two phase flow can greatly increase pressure drop
 - Choked flow (normal shock) at exit adds extra pressure drop

$$\dot{m}_{g,exit} = \frac{\dot{Q}_{ss}}{2(h_{g,exit} - h_{liq,entrance})}$$

Barron, Cryogenic Systems, pg. 421



Effects of Back Pressure

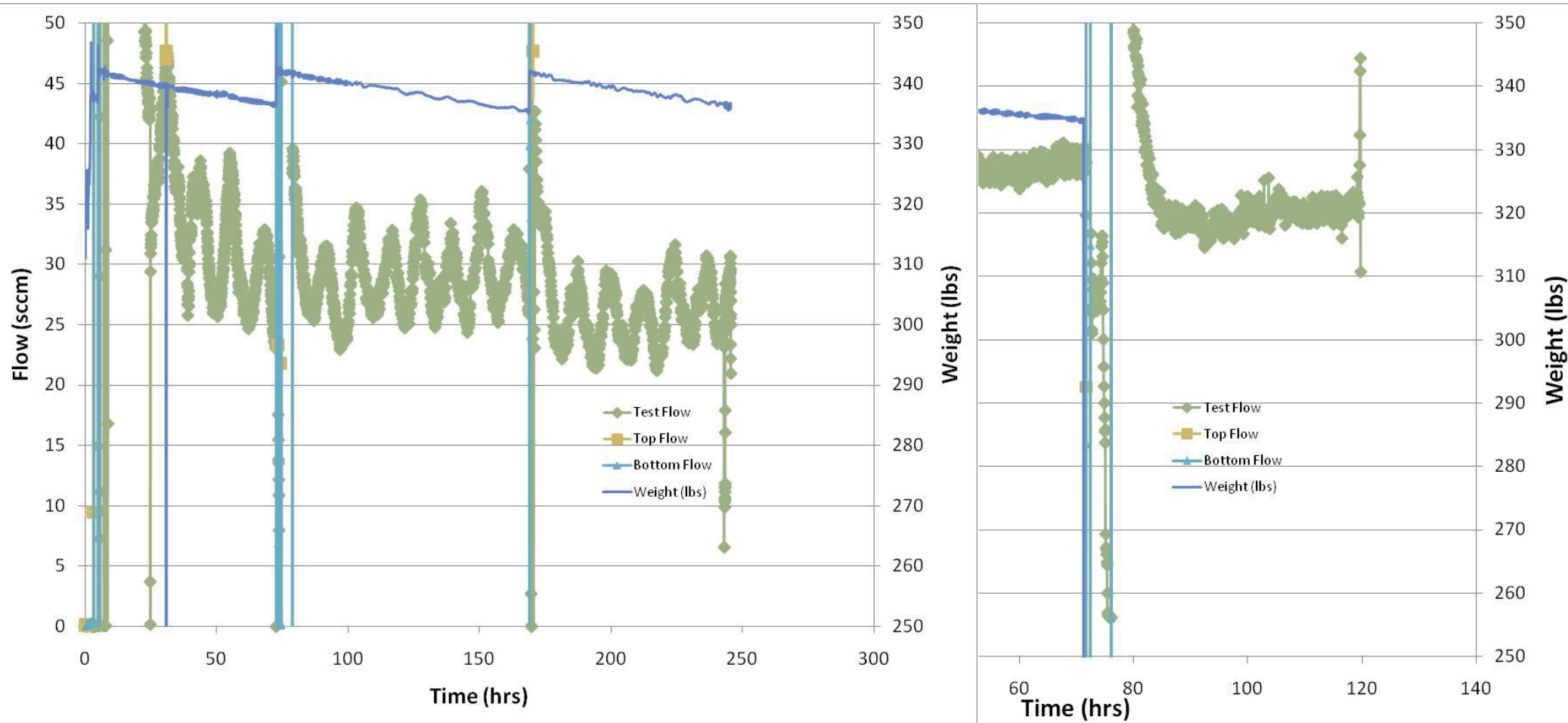

Back Pressure Controlled



Venting & Flaring

- Insulations allow heat into cryogenic systems, no matter how small
- Will increase pressure unless system is vented
- Flaring is a process of burning a flammable gas as it is vented
- Venting is preferred (and cheaper) method for low flow rates



Venting

- Systems can be vented as long as there is not a build-up of flammable gas in an oxidizing atmosphere
 - Hydrogen gas will generally go straight up unless appreciable velocity when exiting horizontal pipes
 - At KSC, the flow rate limit for hydrogen is 0.5 lbm/s
 - At GRC, the flow rate limit for hydrogen/methane is 0.25 lbm/s
- Vent light gasses so they will disperse into atmosphere (i.e. high up)
- Want gas to be as warm as possible when venting
- Vapor cloud is not good indication of amount of vented gas (depends on humidity) or location of gas (cloud is condensed water droplets, not actual gas)



Flaring

- Use propane system to burn hydrogen (or methane or other combustible vent flow)
- Main Method used is flare stack with gas seal
 - Burns up to 100 kg/s hydrogen flow
 - Also used for methane/natural gas systems
- KSC also has a burn pond
 - For very high flow rates
 - Burns the hydrogen vented just above water level

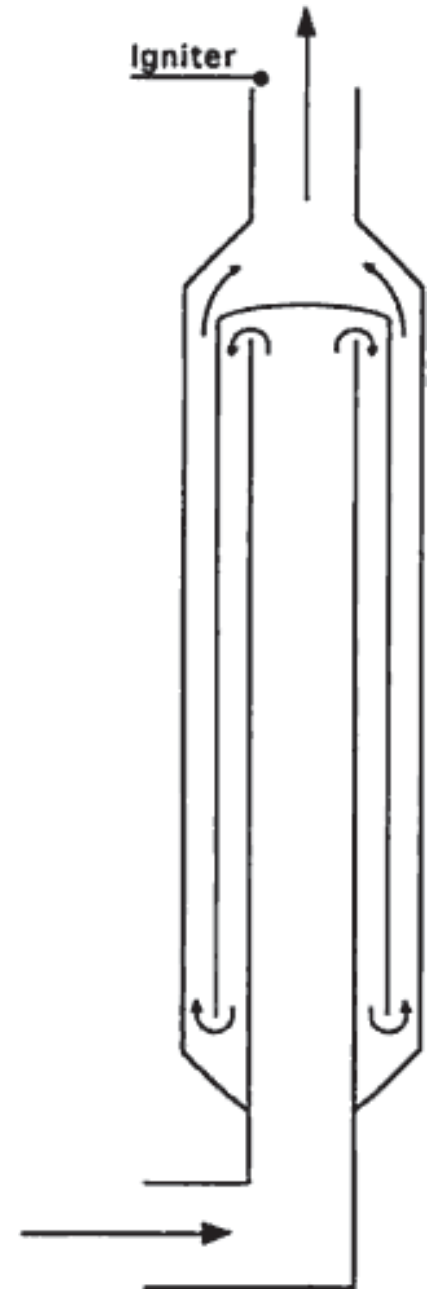

TVS Basic Principles



Heat input from warm surroundings causes both temperature and pressure to increase in a cryogenic propellant tank unless a thermal control technique such as TVS is employed

TVS concept

A small quantity of liquid is sacrificed (vaporized and vented from tank) to maintain propellant temperature and to control tank pressure

1. Vent flow expanded through a Joule-Thomson device to a lower pressure; becomes a colder, two-phase mixture
2. Vent flow goes through cold side of a heat exchanger, absorbing heat and is completely vaporized
3. Vent flow is vented to low-pressure external environment
4. Liquid flows through warm side of heat exchanger and is cooled
5. Cooled liquid is pumped through an axial jet (or spray bar, etc.)
6. Forced convection flow mixes with bulk liquid, promoting cooling and pressure reduction

A method of venting in microgravity

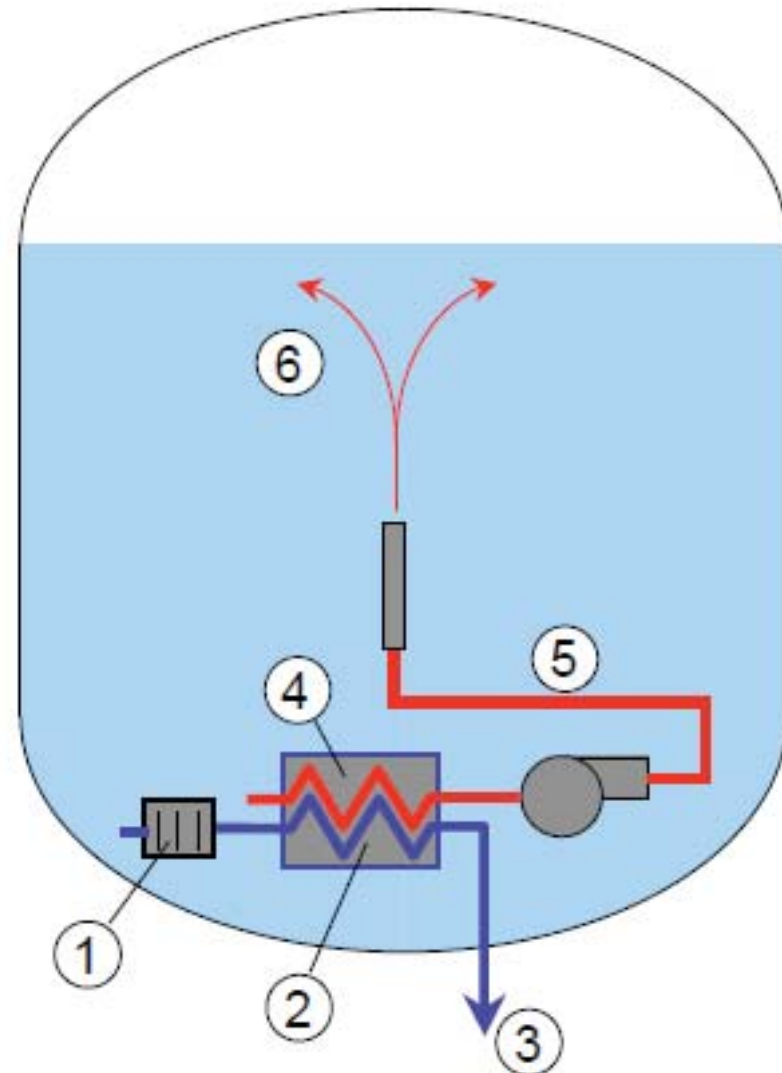



Example Test Data: Controlling Temperature or Pressure

TVS Test C, 50% fill, with GHe, Axial Jet & Spray Hoops Combined

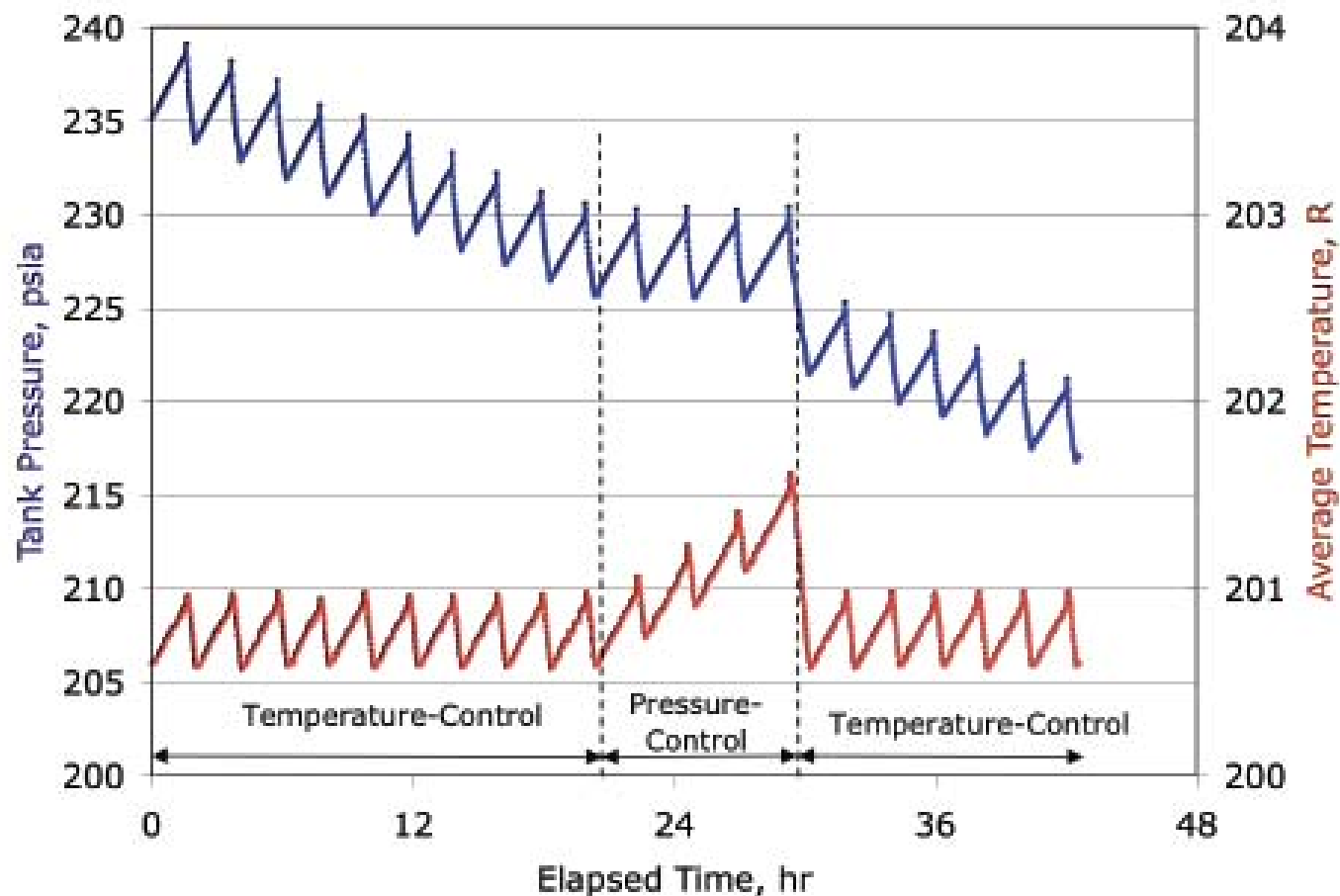



Cryogenic Fluid Management Technologies

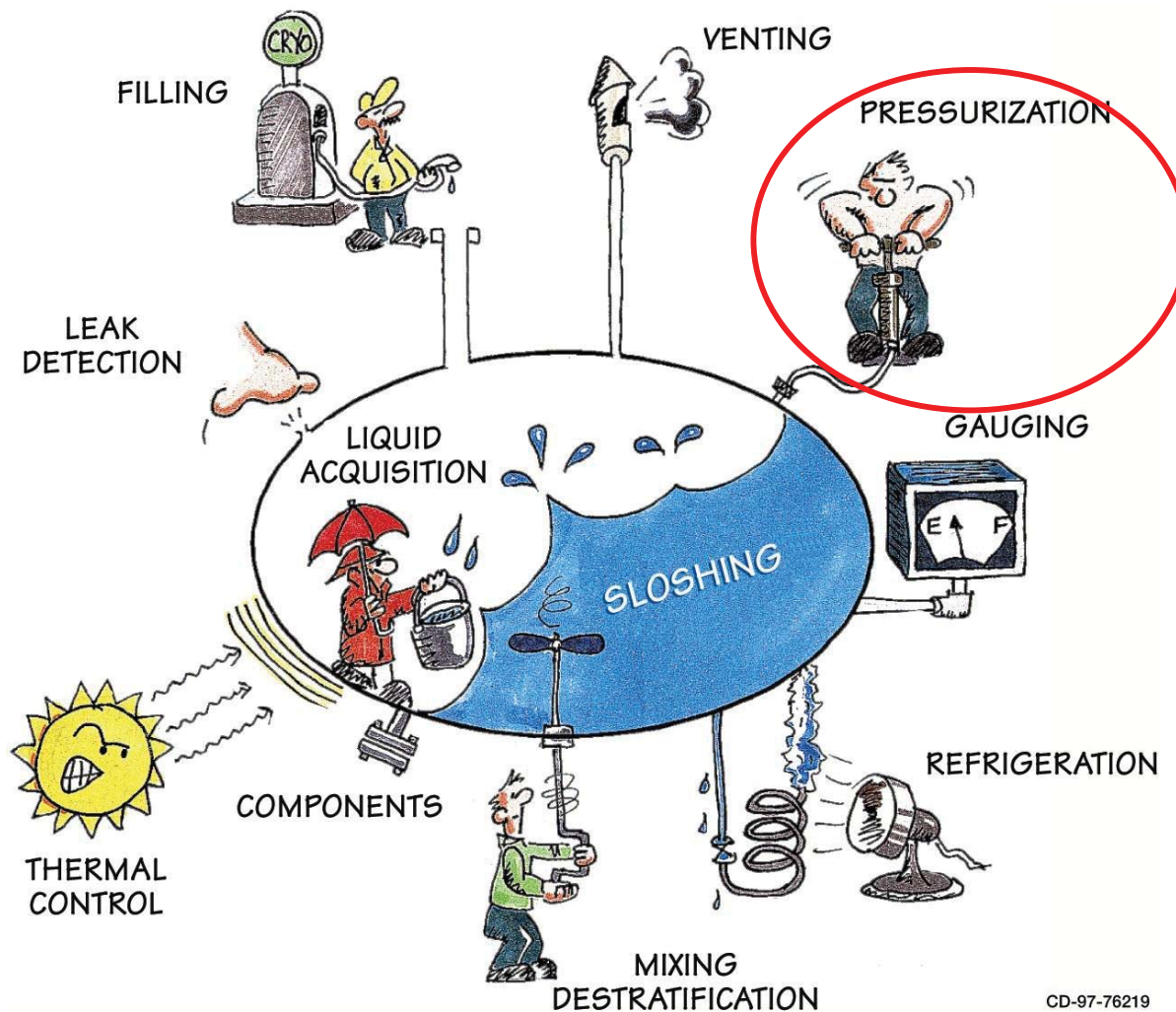

Pressurization

- Usually done to facilitate liquid extraction
 - Provides energy potential to force fluid flow
 - Subcools liquid below tank pressure
- Autogenous Pressurization
 - Use the fluid to pressurize itself
 - Usually manifests as a vaporizer attached to a tank
 - Cryogenic tanks will self-pressurize
 - Just close the vent valve and watch!
- Non-Autogenous
 - Use a different vapor species to pressurize
 - i.e. helium in hydrogen
 - Sometimes multi-species fluid is not desired (i.e. engine)

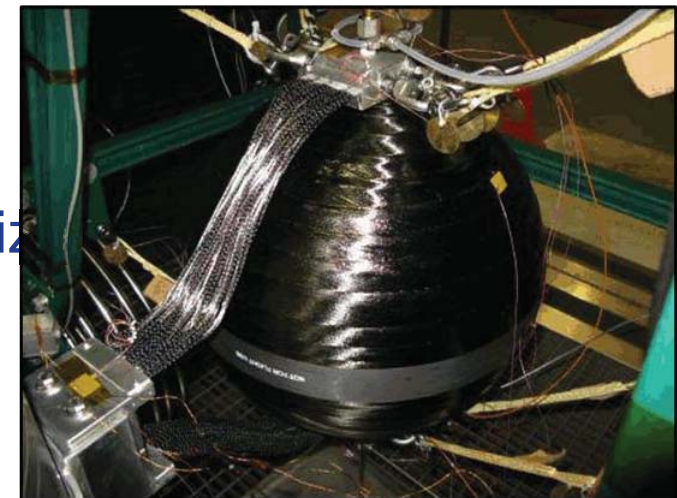

How are these systems pressurized?





Cryogenic Fluid Management Technologies

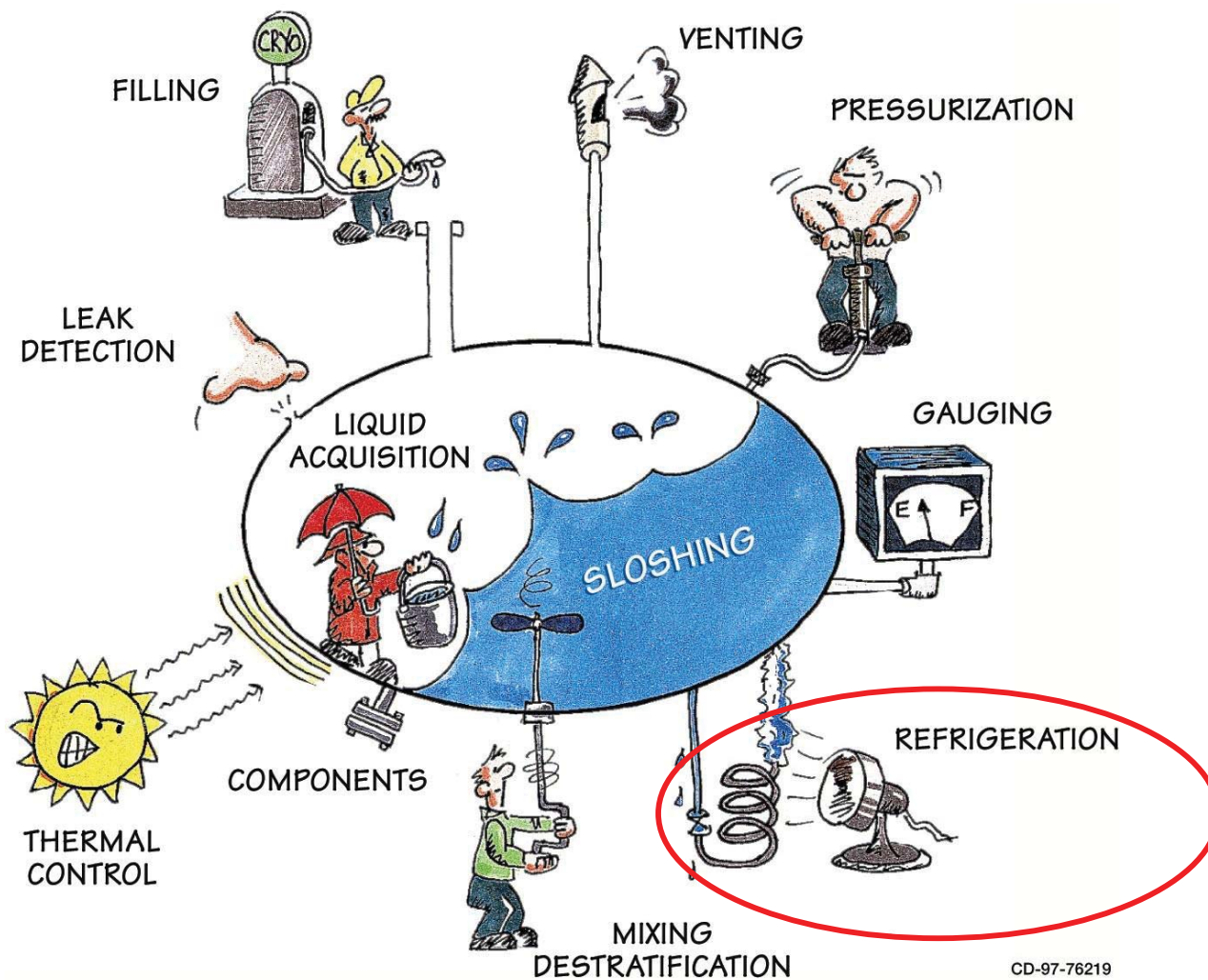

CD-97-76219



Refrigeration

- What is a cryocooler
- Types of cycles

Fundamentals

- A cryocooler is a refrigeration machine capable of producing and maintaining cryogenic temperatures (> 120 K)
 - A liquefier is an open cycle refrigerator that has unbalanced flow path
- Processes are similar to higher temp refrigeration cycles
- In general, four steps required to produce refrigeration
 - Work gets done on a system. Entropy is decreased. Requires input power.
 - Gas Compressor, paramagnetic order, adsorption
 - High temperature heat rejection. Temp and entropy is decreased
 - Order/disorder transition. Adiabatic. Entropy is increased. Temperature is decreased
 - Gas expansion, magnetic disorder, desorption
 - Low temperature heat adsorption.
 - Isothermal (latent heat) vs isobaric (sensible heat)
- In addition, cryogenic refrigeration requires an internal heat exchanger to conserve the cold produced and allow the compressor to operate at ambient temperatures.

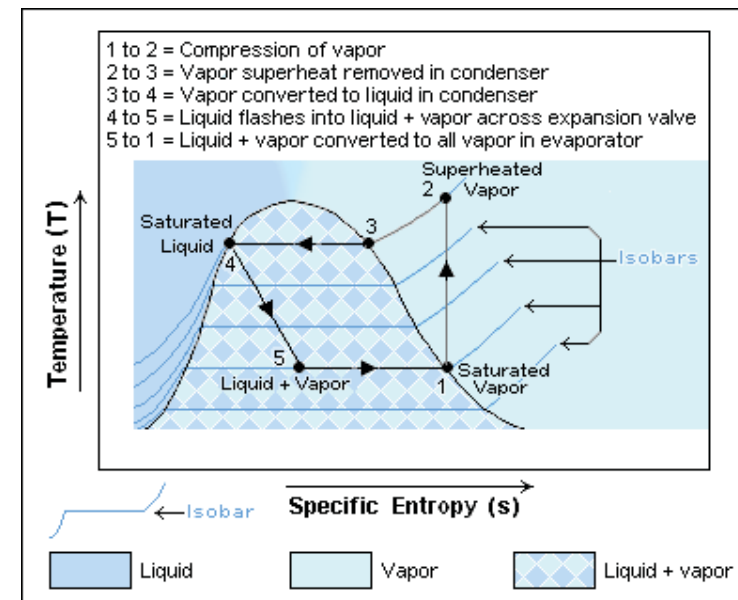
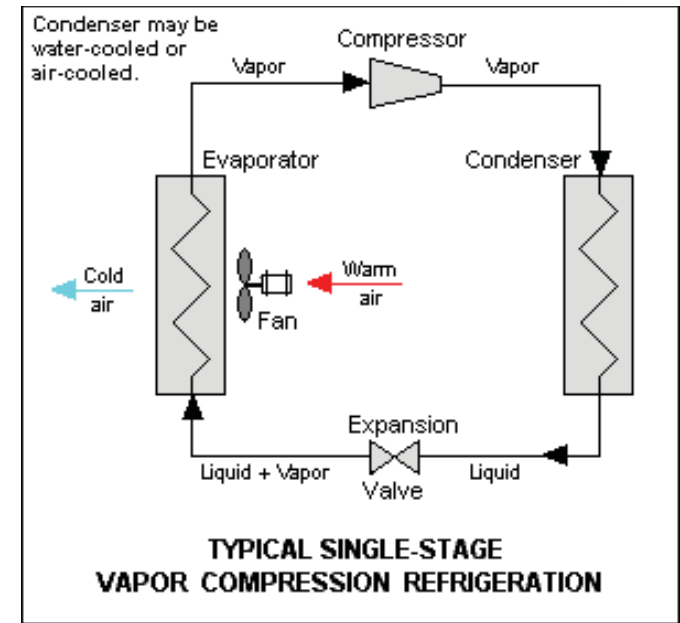



Fundamentals

- Coefficient of Performance (COP) is defined as energy removed at source temperature divided by work needed

$$COP = Q_c / W_{net}$$

- Since $Q = T ds$ and $W_{net} = Q_{net}$ we find that

$$COP_{ideal} = \frac{T_c}{(T_h - T_c)}$$

Carnot first derived ideal COP

Sink Temperature	300 K	
Source Temperature	COP _i	W/Q
K		
111.7	0.593	1.69
90.18	0.430	2.33
77.36	0.347	2.88
20.27	0.072	13.8
4.2	0.0142	70.4
1	0.003344	299
0.1	0.000333	2999

$$W_{net} = Q_c * \frac{1}{\eta} * \frac{(T_h - T_c)}{T_c}$$

Actual work



Fundamentals

- Cryocooler performance is described by specifying the net cooling power at the cold temperature
 - For example a single stage device might provide 1 W at 35K
 - A two stage device may provide 1 W at 35K and 5 W at 90K
- Cryocooler performance curves describe the capabilities
- Another important parameters is the no load temperature

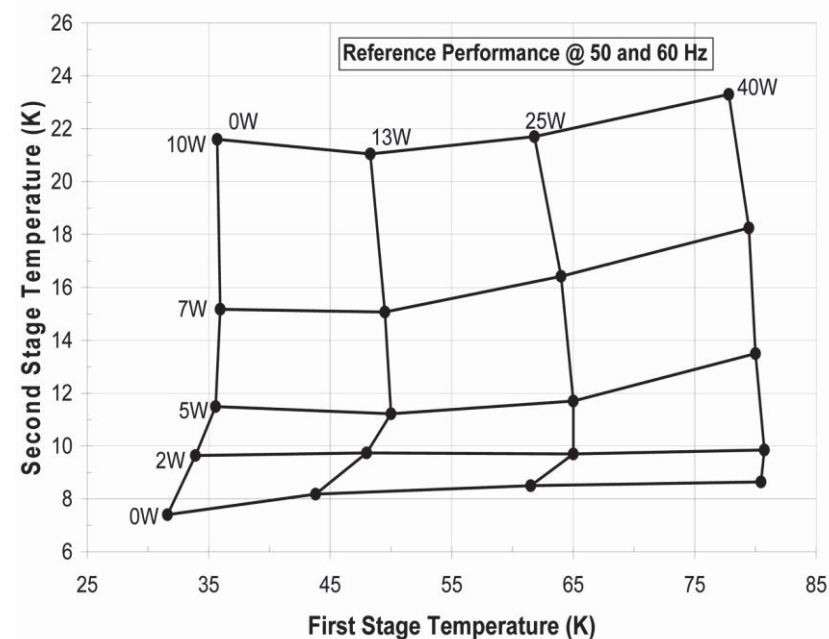
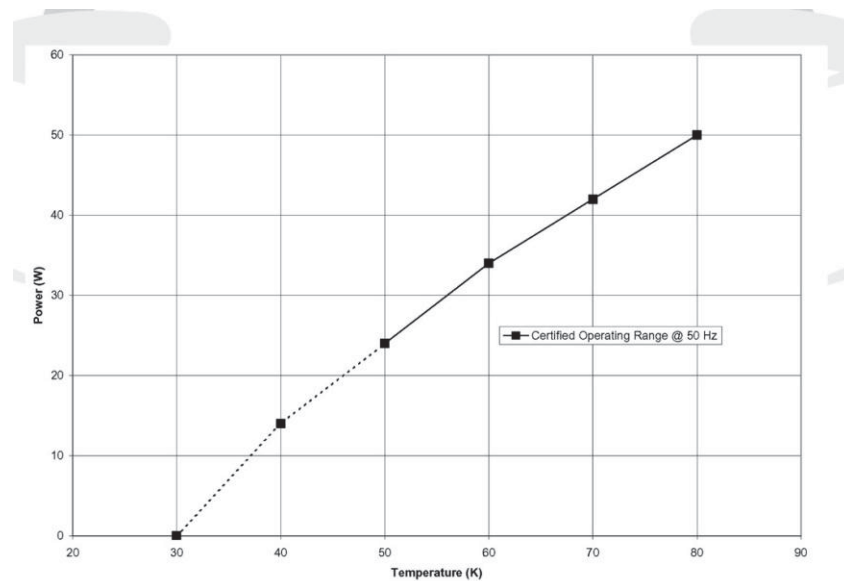



Classification of Cryogenic Refrigeration

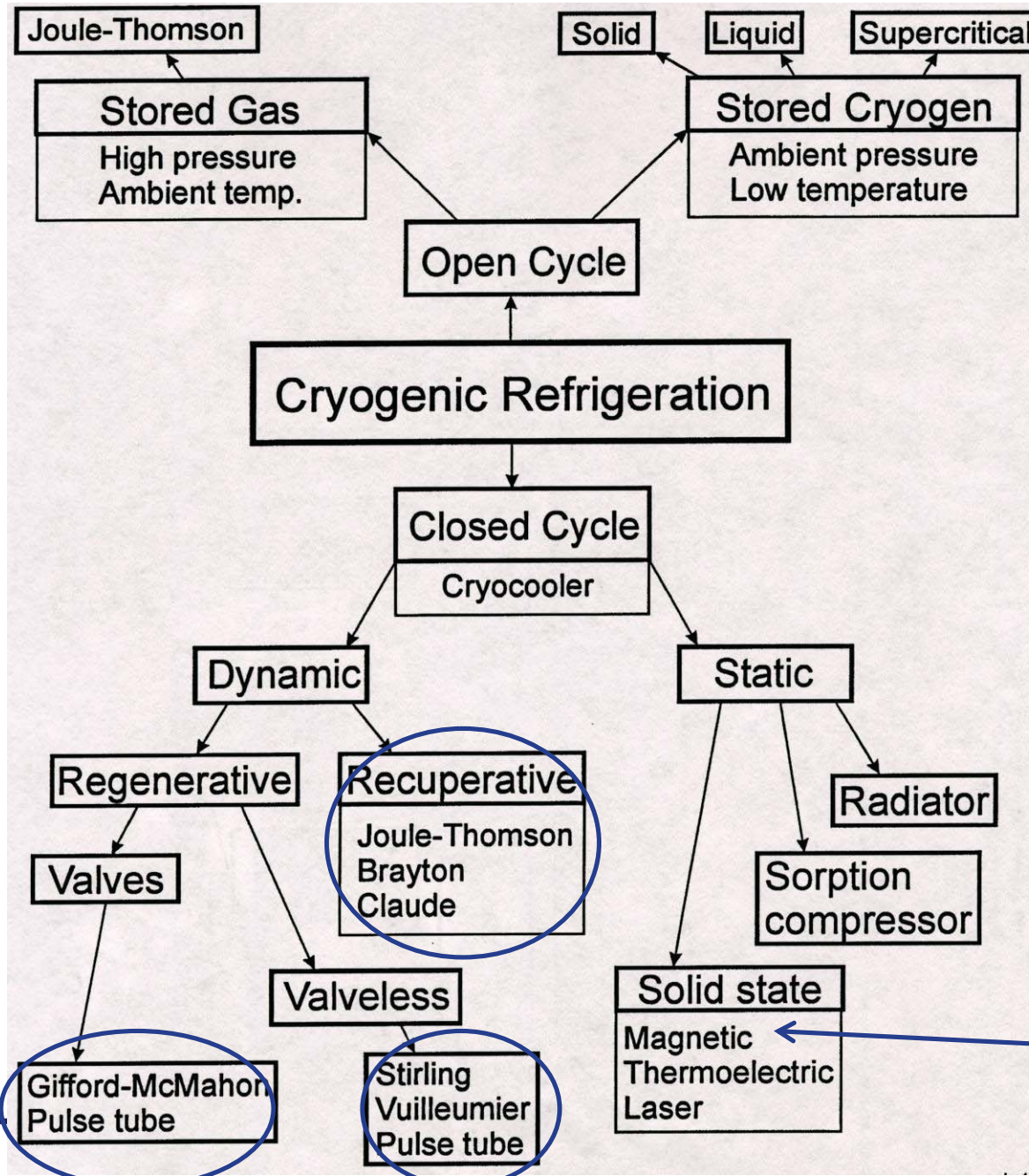

Sub-Kelvin

Reverse Brayton Cycle

- Advantages
 - Low vibration
 - Steady flow
 - Distributed cooling
 - Long life
 - Can be used as liquefier
- Disadvantages
 - Expensive
 - Difficult to miniaturize
 - Large recuperator needed
- Applications
 - Large scale plants
 - NICMOS Cooler
 - Propellant zero boil off

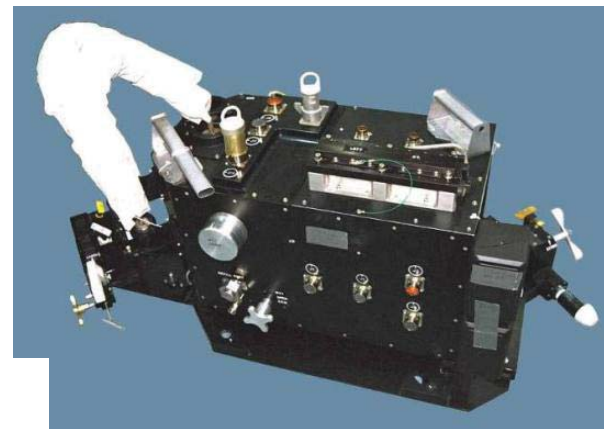



Gifford McMahon (GM)

- Advantages
 - High reliability
 - Low cost
 - Long life
 - Easier to integrate
- Disadvantages
 - Large and heavy
 - Displacer vibration
 - Low efficiency
- Applications
 - Cryopumps
 - MRI and laboratory magnets



Pulse Tube

- Advantages
 - High efficiency
 - No cold moving parts
 - Lower vibration
 - Moderate cost
- Disadvantages
 - May not scale up well
 - Point cooling sink
 - Low temperature regenerators
- Applications
 - IR sensors
 - Space applications

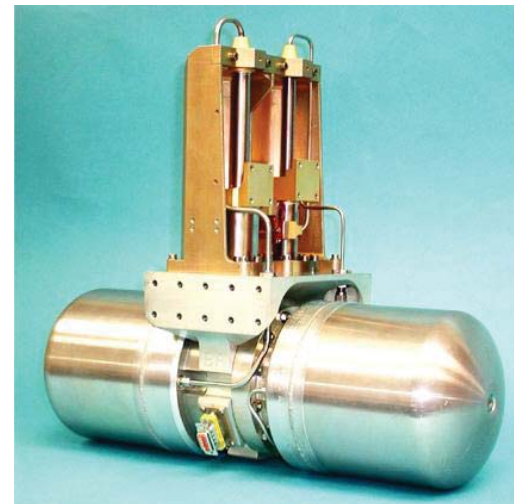

Cryogenic Fluid Management Technologies

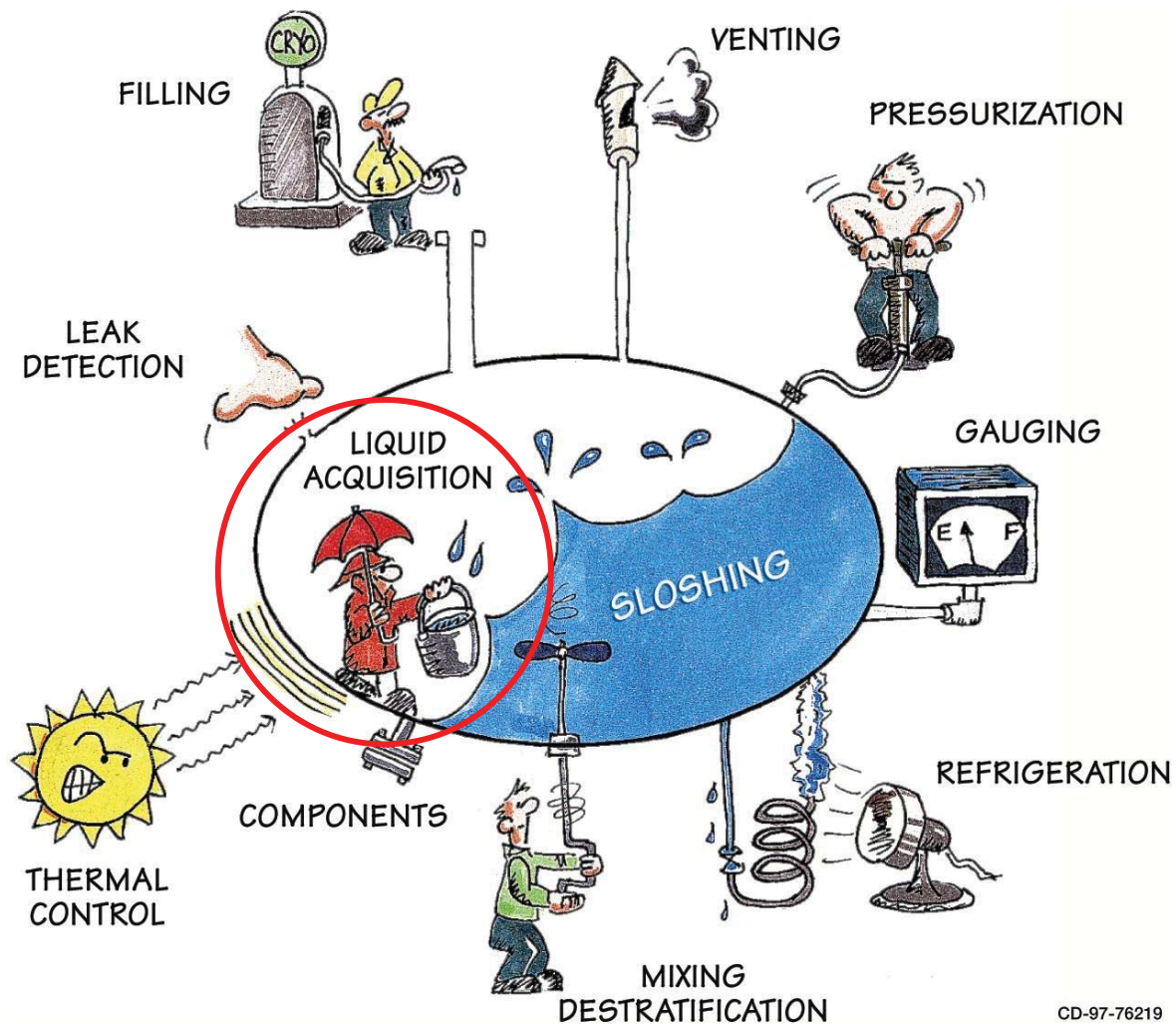

CD-97-76219

Liquid Acquisition 1-g

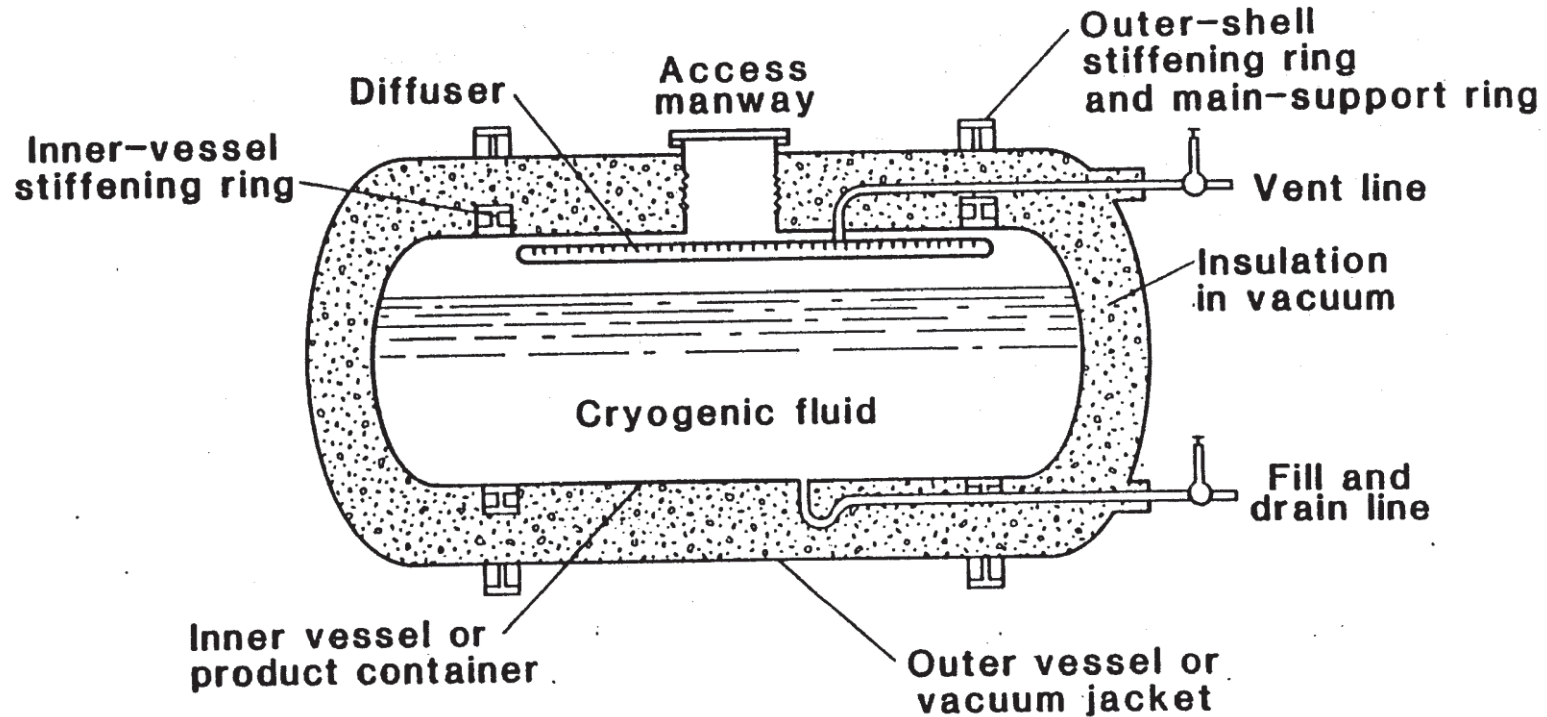

Liquid Acquisition Devices – not 1-g

- Vanes are much simpler design, but may not meet flow rate demands
- Sponges favorably position ullage and liquid, but are heavy

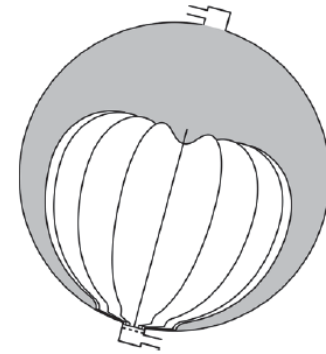
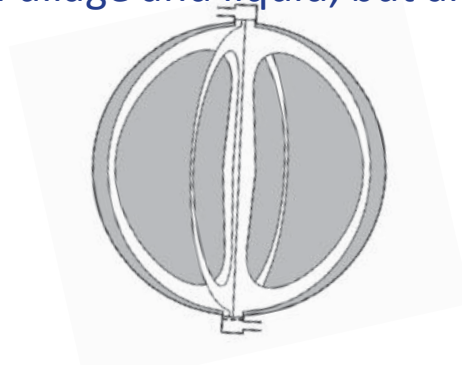

- Screen channel gallery arms are best in multi-directional, multi-g environments
- Multiple screen mesh styles – square, Dutch Twill (tortuous flow path)
- Warp/shute wires characterize the mesh (ex. 325x2300)
- LADs rely on capillary flow, and wicking and surface tension forces for barrier to vapor ingestion
- No optimized LAD configuration; fine mesh screens = good wicking & screen retention vs. high pressure drop and potential for clogging

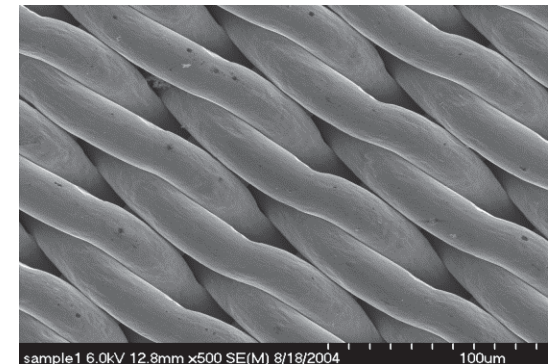
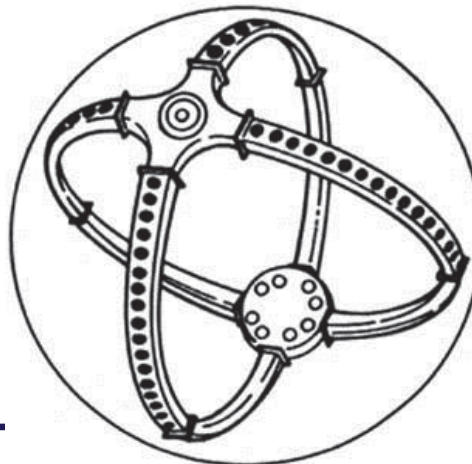
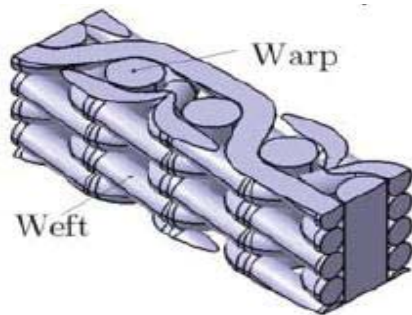

Cryogenic Fluid Management Technologies

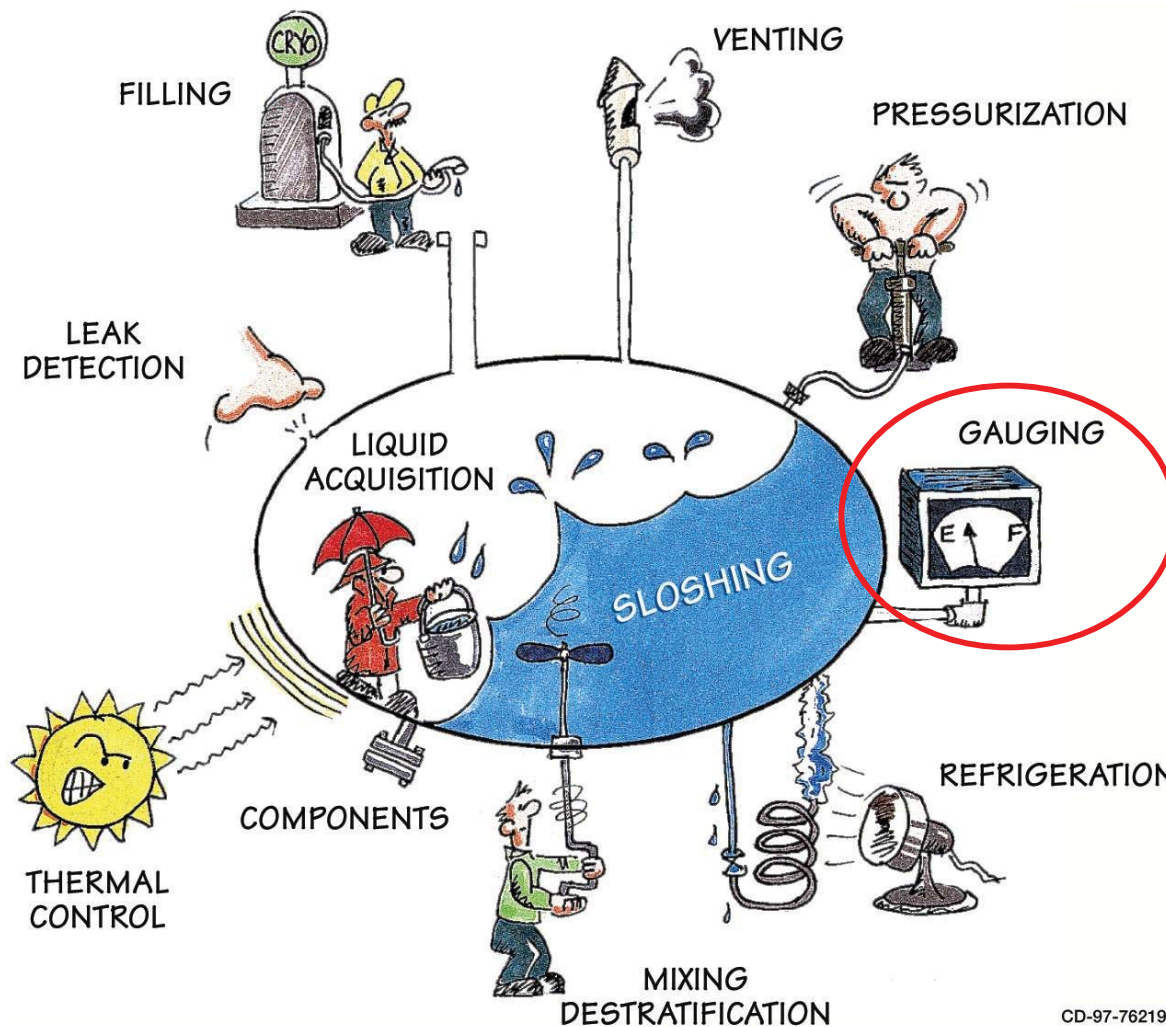



Mass Gauging – 1g

Method	Advantages	Disadvantages
Wet-dry sensors - “Hot” wires, diodes, thermistors	<ul style="list-style-type: none"> - Simple device - Also used externally on thin tank walls with high heat leak 	<ul style="list-style-type: none"> - Point sensor, only gives local information. - Erratic level readings during slosh.
Capacitance probe	<ul style="list-style-type: none"> - Continuous indicator; simple device 	<ul style="list-style-type: none"> - Bulky hardware for large tanks.
Delta-P - measures pressure head to determine level	<ul style="list-style-type: none"> - Flight history, used on Centaur upper stage - Simple device - Continuous indicator 	<ul style="list-style-type: none"> - Sensor drift may cause inaccuracy on long missions.
Fiber Optic Sensor	<ul style="list-style-type: none"> - Wet/dry principle of operation - Flexible, lightweight probe 	<ul style="list-style-type: none"> - Point sensors - Low TRL
Ultrasonic	<ul style="list-style-type: none"> - Continuous sensor 	<ul style="list-style-type: none"> - Limited gauging range - Stray acoustic reflections problematic - Weak reflection from LH2 interface



Capacitance Probe

Capillary rise is given by
$$h = \frac{2\sigma}{\rho g(r_1 - r_2)}$$

Tube gap, $r_1 - r_2 = 2 \text{ cm}$

At 10^{-3} g , $h = 28 \text{ cm}$ for LH2

At $30 \mu\text{g}$, $h = 9.3 \text{ m}$ for LH2

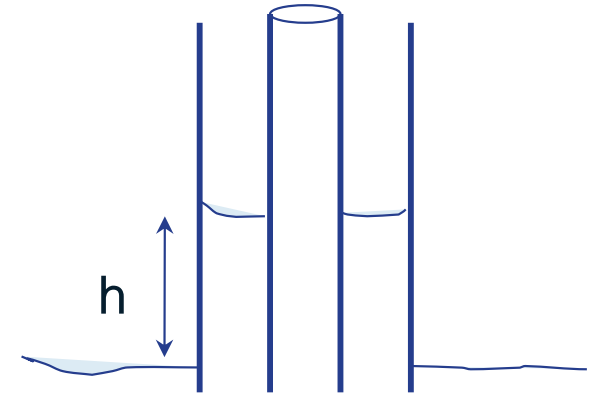

- Change in height correlated to fill level.
- Electrical capacitance between the two cylinders changes with height.
- Must be recalibrated for different fluid.



Si Diode Rakes

Principle of operation

$I = 30 \text{ mA}$

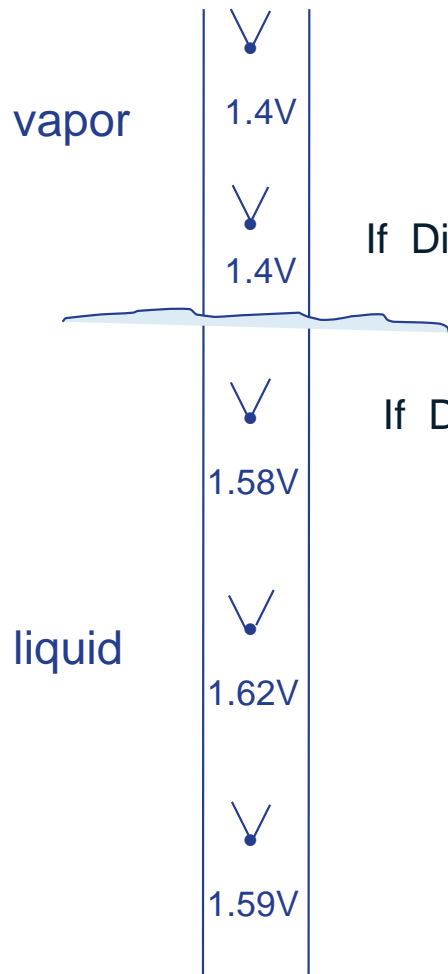

If Diode_Voltage < Threshold_Voltage then vapor

If Diode_Voltage > Threshold_Voltage then wet

Fluid mass = (Volume of tank below wet diode) · (density of fluid (P,T))

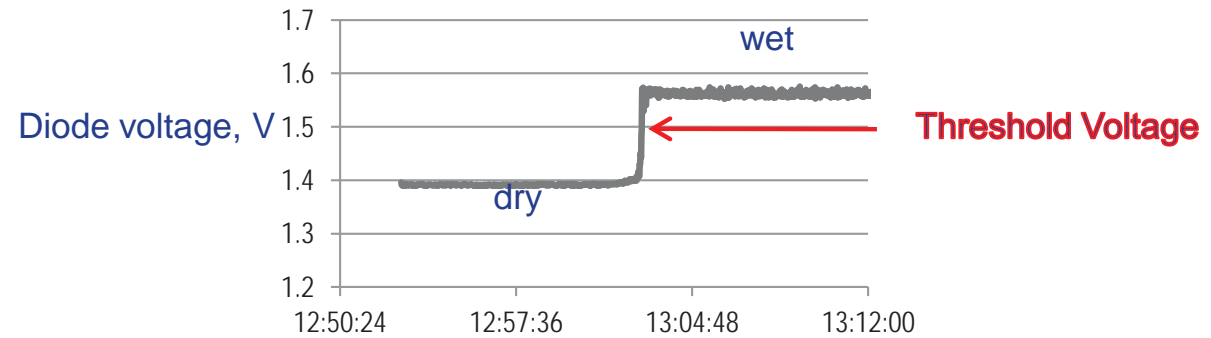



Settled low-g fluid interface configurations, 50% fill

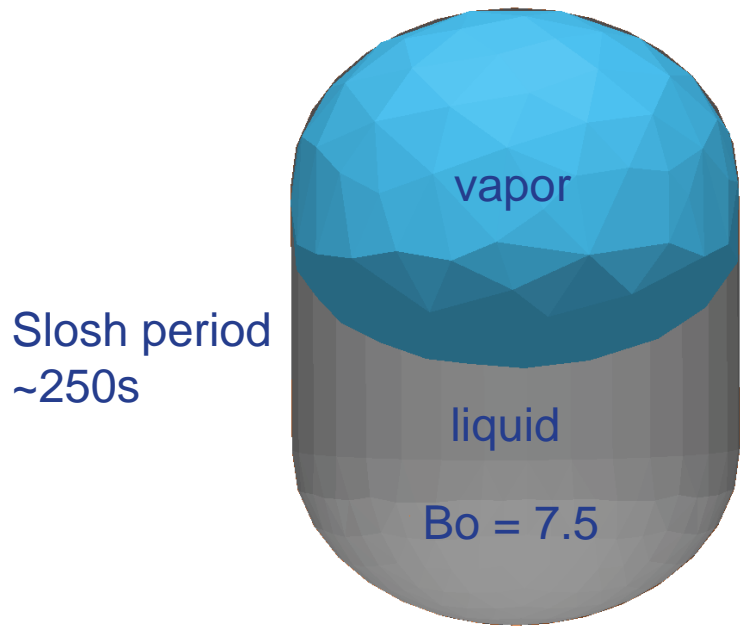

2 m tank

Acceleration = 30 μ g

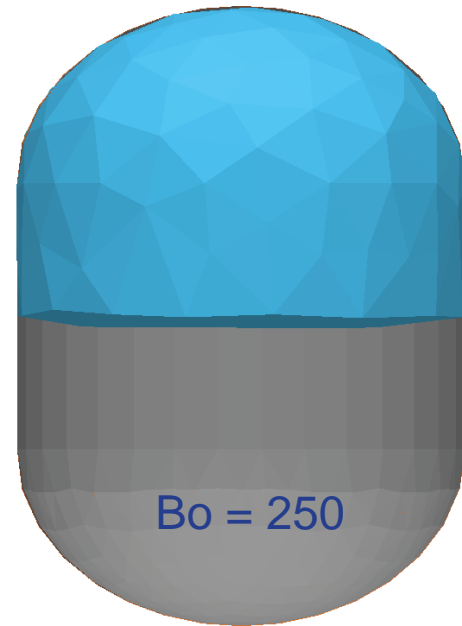

Slosh period ~40s

Acceleration = 1 mg

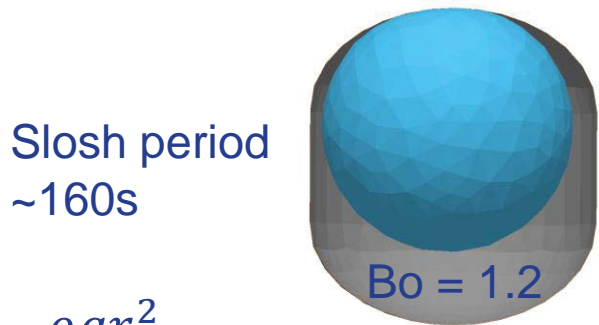

Slosh period ~160s

0.5 m tank

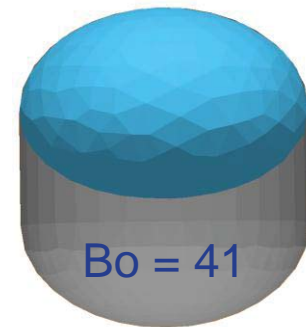

Slosh period ~30s

$$Bo = \frac{\rho g r^2}{\sigma}$$

Surface tension, sloshing effects may limit settled gauging accuracy



Unsettled Mass Gauging

Method	Advantages	Disadvantages
Radio Frequency Mass Gauge	<ul style="list-style-type: none"> • Fast, low power • Simple tank hardware • Tested in LH2, LOX, • Low-g aircraft testing 	<ul style="list-style-type: none"> • Higher complexity for both electronics and signal processing. • Best suited to relatively clean (uncluttered) tank hardware .
Pressure-Volume-Temperature (PVT)	<ul style="list-style-type: none"> • May utilize existing hardware • Flight history for storable propellants • Insensitive to shape of ullage volume and internal tank hardware 	<ul style="list-style-type: none"> • Relatively slow response (tens of minutes). • Needs isothermal conditions for accuracy. • Not well suited for very large tanks or LH2. • Requires non-condensable pressurant gas
Bookkeeping method	<ul style="list-style-type: none"> • No additional hardware 	<ul style="list-style-type: none"> • Uncertainty generally increases as fill level decreases

RF Mass Gauging

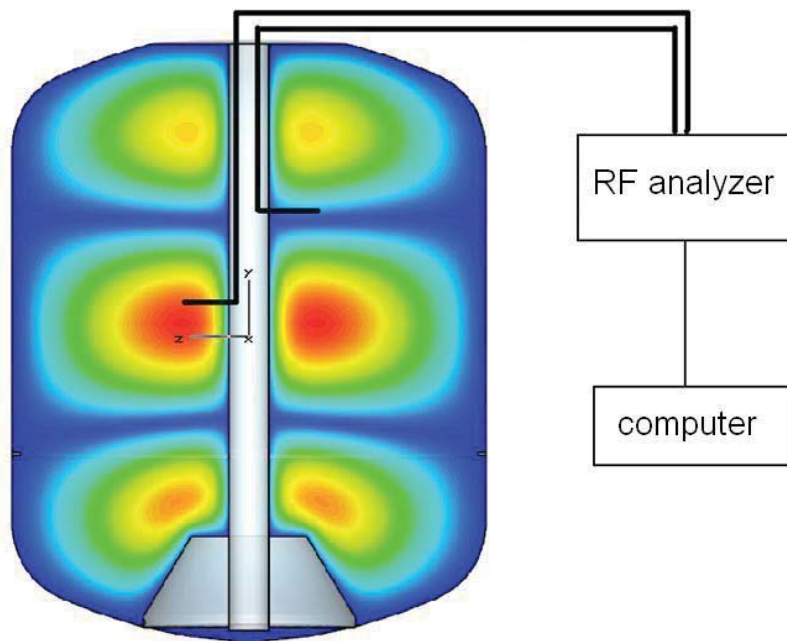

- The tank RF spectrum changes with fill level, since the dielectric fluid slows the speed of light
- The basis of the RFMG is that these changes can be accurately predicted

- Metal tank has natural RF modes

$$f \sim c/L$$

- RF network analyzer measures the tank spectrum

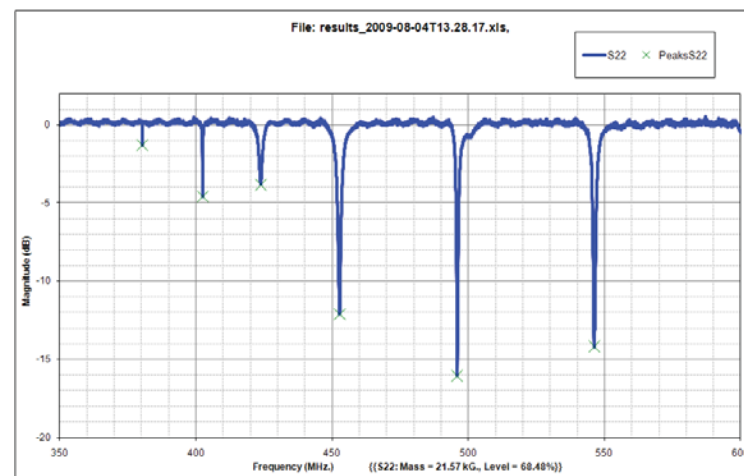

- RFMG software finds the peaks, compares the frequencies to a database of simulations, and returns the best match %fill-level information



CRYOGENIC TESTING



Objectives

- Introduce the student to what may be experienced during testing of cryogenic systems and what types of measurements and instrumentation may be desired, needed, or required.
- Provide an overview of cryogenic testing and low temperature hardware used in cryogenic systems
- Offer some perspective on “What’s important to the thermal/fluids analyst of cryogenic test systems”.

Before a single data point is produced, the manpower & costs to safely execute a cryogenic test from start to being “test ready” is daunting



Presentation Outline

- Facility Systems
- Test Hardware & Components
- Instrumentation & Controls
 - Temperature, Pressure & Flow
- Materials
- Pressure Systems
- Cryogenic Safety
 - Hydrogen and Oxygen
- Preparation & Checkout
- Formal Test Operations
- Data Analysis & Reduction

Introduction

Temperature Range of Cryogenic Liquids (< -240 °F)

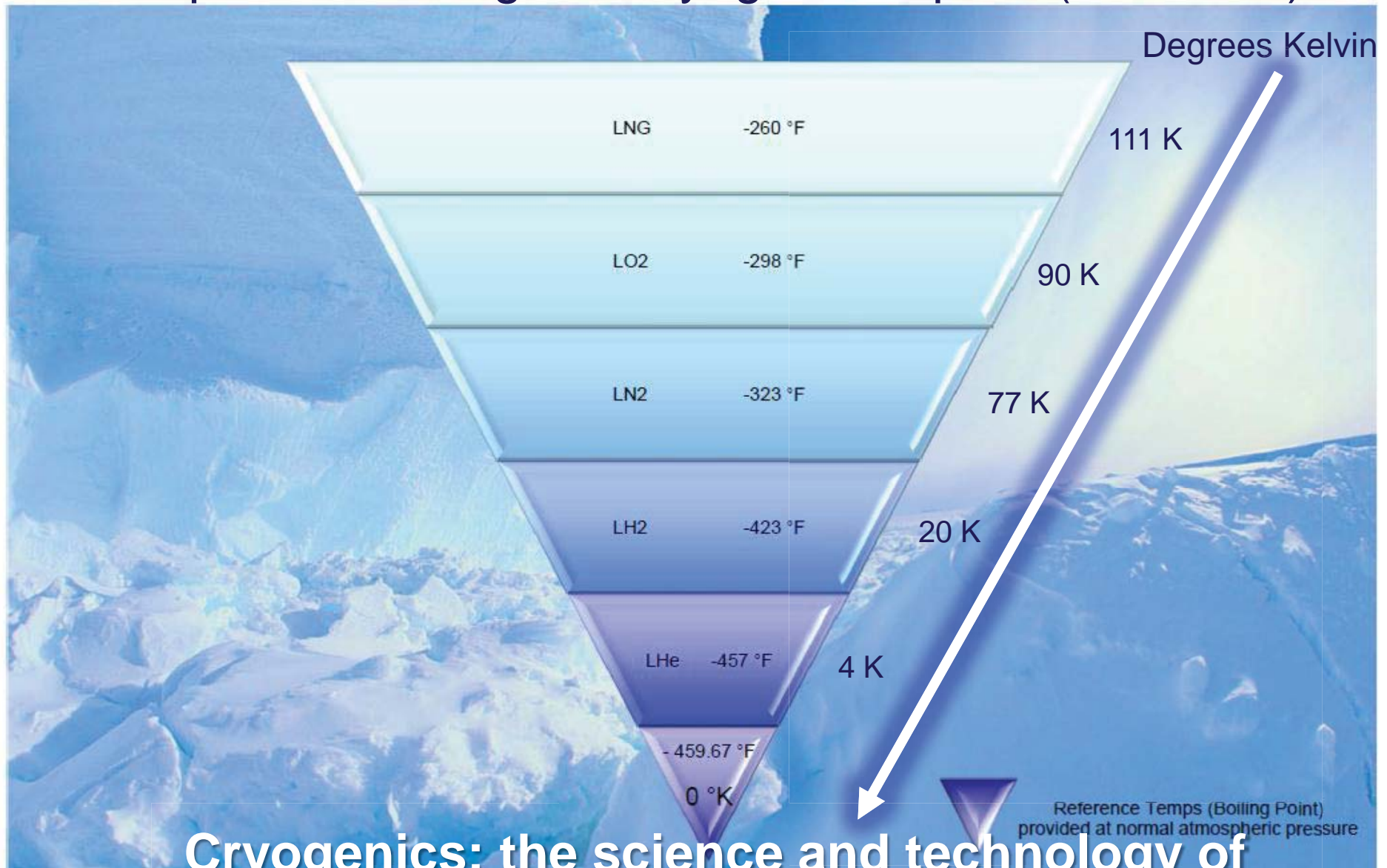

**Cryogenics: the science and technology of
temperatures below 120 K**



Typical Elements of Cryogenic Test Facilities

- Fluids & Gas Supply
- Dewars
- Piping / Tubing Systems
- Instrumentation & Controls
- Test Facility & Hardware



Fluids & Gas Supply

High pressure gas available in high pressure tube trailers:

- Oxygen
- Nitrogen
- Helium
- Hydrogen
- Methane

Cryogenic fluids available for dewars:

- Liquid Oxygen (LO₂)
- Liquid Nitrogen (LN₂)
- Liquid Hydrogen (LH₂)
- Liquid Methane (LCH₄)

- NASA Glenn maintains a fleet of high pressure tube trailers to provide gas to test facilities (70,000 SCF @ 2200 psi)
- Smaller quantities of high pressure gas can be obtained from gas suppliers in individual cylinders
 - K-bottle, 2200 psi, 235 SCF GN₂, 1.54 ft³ H₂O volume
- NASA Glenn maintains a fleet of roadable dewars to provide cryogenics to test facilities (LN₂, LH₂, LCH₄, LO₂), capacity range 250 – 15,000 gallons
- Smaller quantities (45 – 100 gallon) can be obtained from industrial gas suppliers in portable dewars

Fluids & Gas Supply



High pressure tube trailer



Stationary cryogenic liquid dewars



Portable dewars



High pressure gas cylinders



Roadable cryogenic dewars

Cryogenic Storage Dewar – Schematic

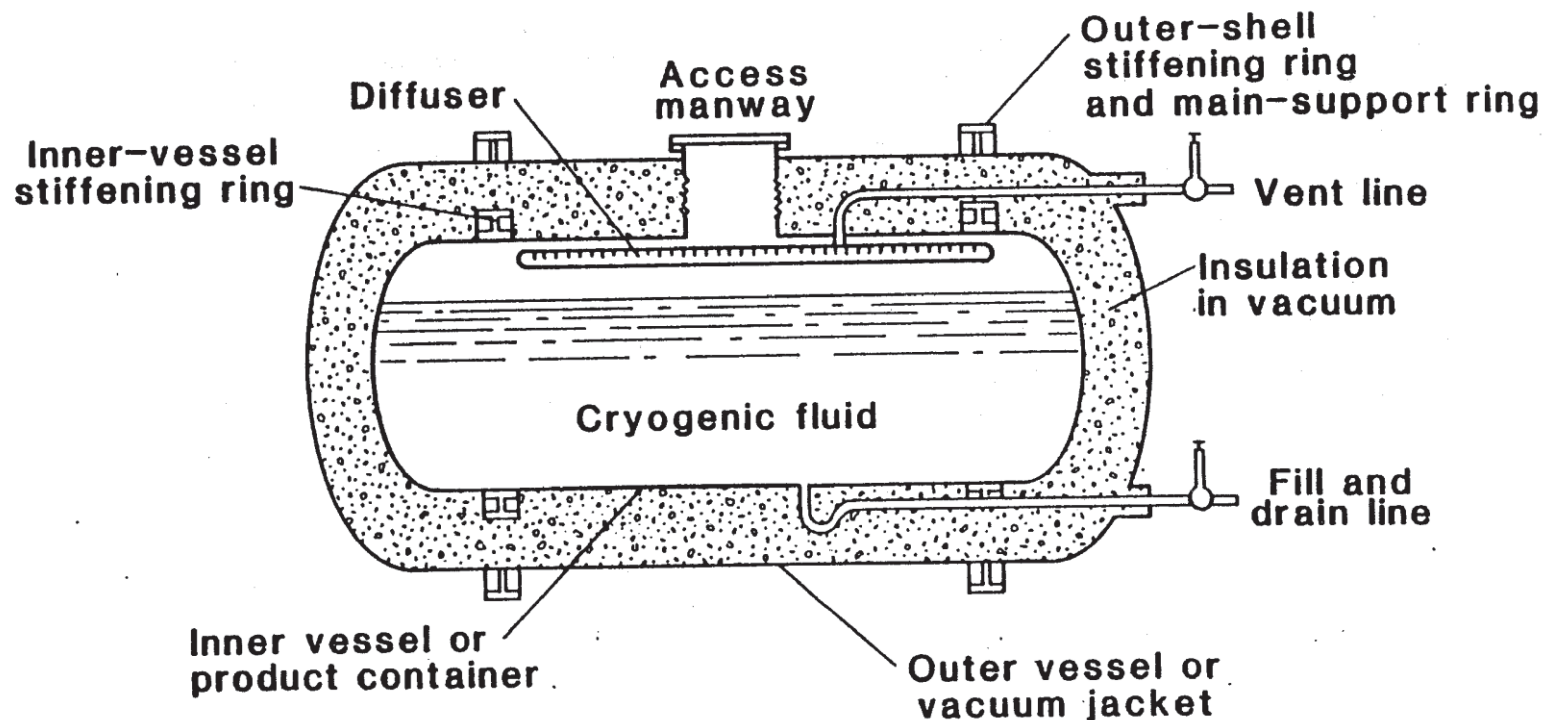



Cryogenic Dewar – P&ID and Design Data

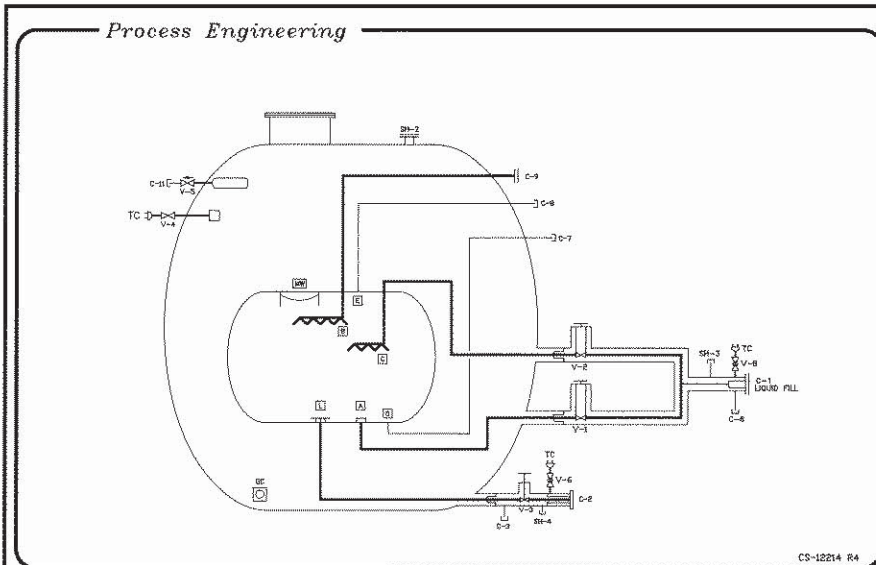

PROCESS ENGINEERING			
ITEM	FUNCTION	DESCRIPTION	SIZE
V-1	BOTTOM FILL VALVE	PART OF V-J FILL MANIFOLD, CV	3"
V-2	TOP FILL VALVE	PART OF V-J FILL MANIFOLD, CV	3"
V-3	LIQUID DELIVERY VALVE	V-J, EXT.STEM. W/BAYONET, CV	3"
V-4	TANK VAC GAGE VALVE	HOKE 4261 P2Y	--
V-5	EVACUATION VALVE	DIAPHRAGM TYPE, IRON BODY, ITT	3"
V-6	VAC GAGE VALVE (ON V-3)	PART OF V-J MANIFOLD-CV	1/4"
V-8	MANIFOLD VACUUM GAGE VALVE	PART OF V-J FILL MANIFOLD, CV	--
C-1	FILL BAYONET	PART OF V-J VALVE ASSEMBLY, CV	--
C-2	DELIVERY BAYONET	PART OF V-J VALVE ASSEMBLY, CV	--
C-3	EVACUATION CONNECTION	PART OF V-L DELIVERY ASSEMBLY, CV	--
C-4	EVACUATION CONNECTION	PART OF V-J FILL MANIFOLD, CV	--
C-7	BOTTOM LIQUID LEVEL CONNECTION	--	1/4"
C-8	TOP LIQUID LEVEL CONNECTION	--	1/4"
C-9	VENT/PRESSURE CONNECTION	4" 350# RF FLANGE	4"
C-11	TANK EVACUATION CONNECTION	3" NPT PLUGGED	--
SH-2	JACKET SAFETY	DUAL O-RING SEAL, PEI	0"
SH-3	V-J FILL MANIFOLD AKT. SAFETY	PART OF V-J FILL MANIFOLD, CV	--
SH-4	DELIVERY VALVE BUNNET SAFETY HEAD	PART OF V-J VALVE & BAYONET ASSY., CV	--
MP	ACCESS MANWAY, BELLWIS/GRINDAWAY	--	--
TC	THERMOCOUPLE VACUUM GAGE TUBE	FREDERICKS 2100-31 MNH	--
GC	GROUNDING CONNECTION(2)	GROUND LUG #L-250	--

CS-12214 R4

Contains information used in thermal & fluids analysis of a cryogenic storage systems:

- Dewar heat load
- Pressurization/ Working Pressure
- Cryogen Outflow
- In-Storage Liquid State

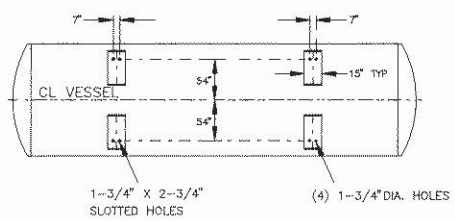
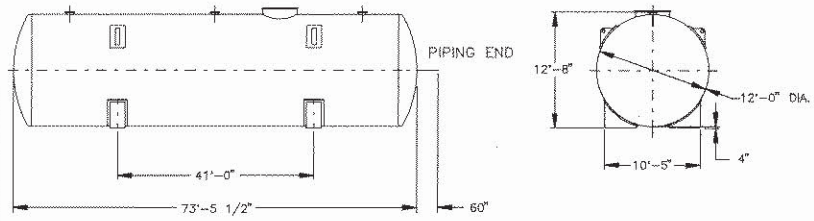

Vessel Design Data	
Inner Vessel:	H-33300-7-100
MAWP:	75 PSIG
Design Temperature:	-423°F TO +100°F
Hydro Test Pressure:	136 PSIG
Vessel Material:	SA-240 T-304LS/S
Code Stamp:	YES
Radiograph:	100%
Outer Jacket:	
MAWP:	Full Vacuum
Design Temperature:	Ambient
Sand Blasting:	YES
Painting:	Imron White
Vessel Material:	A36 CS
Insulation:	Evacuated Perlite
Weights:	
Empty:	108,000 Lbs.
Full of LH2:	128,000 Lbs.
Capacity:	
Full of Water:	33,309 Gallons
At Trycock:	30,000 Gallons

Code ASME Section VIII Division 1 Latest Addenda
Inspected by National Board Inspectors with OH and PA Commissions
Piping ASME/AWS B31.3

INTERNAL LINE SIZES		
LINE	FUNCTION	SIZE
A	BOTTOM FILL	3" NPS
B	VENT/PRESSURIZE	4" NPS
C	TOP FILL	3" NPS
D	BOTTOM GAGE LINE	1/4" NPS
E	TOP GAGE LINE	1/4" NPS
L	LIQUID DRAW	3" NPS

NOTES:
1. ARROWS INDICATE VALVE BODY ORIENTATION, NOT NECESSARILY PRODUCT FLOW DIRECTION.
2. TWO GROUND LUGS REQ'D ON EACH VESSEL FOR 2/0 COPPER CABLE.

NO	DATE	BY	CHKD	RECORD OF REVISION
4	3/7/97	RD		REMOVED LINE "F", C-4 & C-5, CHG TEMP.
3	7/97	RD		REVISED LEGEND, MOVED MANWAY, CHANGED VESSEL DIMENSIONS
2	1/98	RT		ADD JOB NO., CHG PRESSURES AND CAPACITIES.
1	1/98	RT		REMOVED V-10, V-11, C-10, SH-1, CHGD FROM MANWAY ACCESS COLLAR TO GRINDAWAY.

PEI PROCESS ENGINEERING
146 Main Street, PO Box 467
Plaistow, NH 03865

This design is the property of Process Engineering. The reproduction, manufacture or use of any assembly, sub-assembly or part is permitted only if authorized by Process Engineering.

CUSTOMER DRAWING FOR:

MCDONNELL DOUGLAS AEROSPACE
MODEL H-33300-7-100 LH2 TANK

JOB No. C-12396 | F/C#D1/12 | PART No.

APPROVALS | BY | DATE | SHEET 1 OF 1

DRAFTER: WVA 8/3/96 | CHECKER: [Signature] | ENGINEERING DESIGN: [Signature]

CS-12214 | 4 | DRAWING NO. | REV.

Piping & Tubing

Suitable Materials of Construction

High pressure gas –

- Stainless Steel tube or pipe
 - Pipe – larger sizes (typically > 1" P.S.), welded construction.
 - Tubing – 1/8" to 1" tubing size typical, easily reconfigured, assembled with AN (flare) fittings or compression (Swagelok type) fittings
 - Consider nickel alloys (Monel) for high pressure oxygen piping

Cryogenic liquid –

- Stainless steel tube or pipe, copper tubing
- To minimize heat leak into the fluid use either:
 - Vacuum Jacketed (VJ) Pipe – lowest heat leak but expensive and hard to reconfigure
 - Foam insulation – Worse heat leak, but lower cost – often used just to prevent air from liquefying on outside of pipe

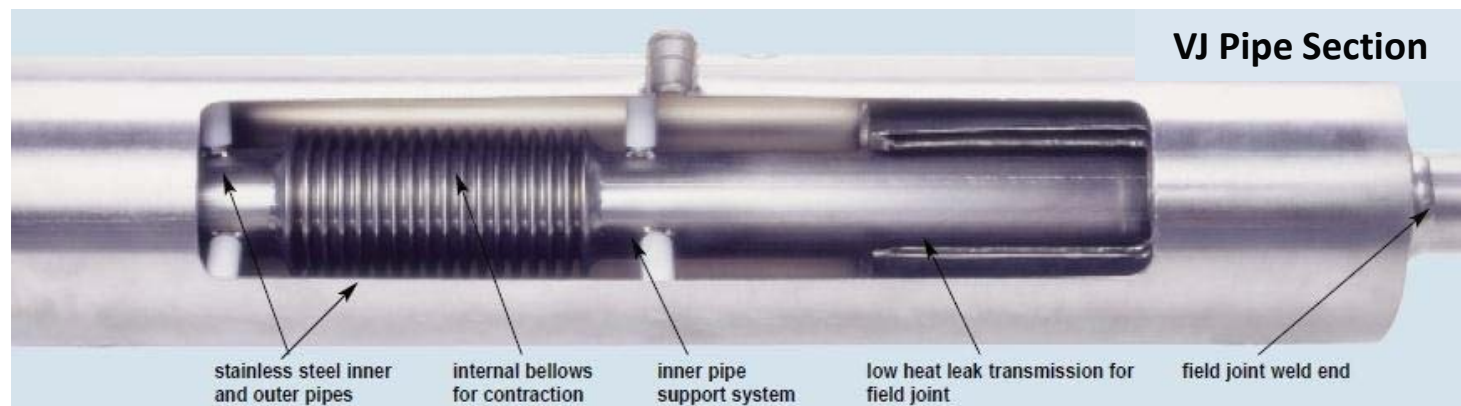



Vacuum Jacketed Piping

- Inner process line for transfer of cryogenic liquid
- Outer line forms vacuum jacket (Sch 5)
- Vacuum annular space
 - Multilayer Insulation (16 – 32 layers Alum-Mylar)
 - Hard vacuum ($< 50 \mu\text{Hg}$, $10 \mu\text{Hg}$ nominal)
 - Vacuum integrity: ($< 1 \times 10^{-9}$ sccs gHe mass sp)
- All stainless steel construction (304L) (ASME B31.3 compliant)
- Inner line supported with low thermal conductivity spacers
- Inner pipe sizes can range from 1/2" to 8"
- MAWP: 100 – 750 psi (150 - 250 psig typical)
- Lowest cryo transfer system design heat leak
- Max. fabrication length: 40 foot spool
- Expensive, high performance, low maintenance

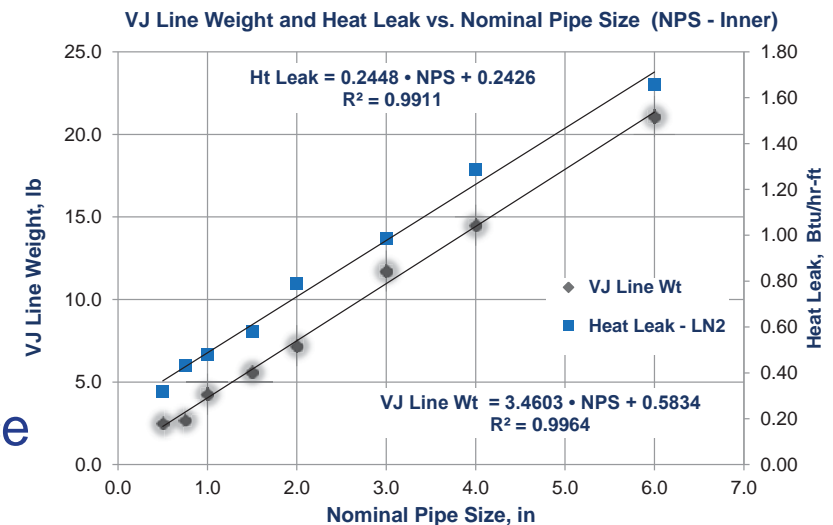
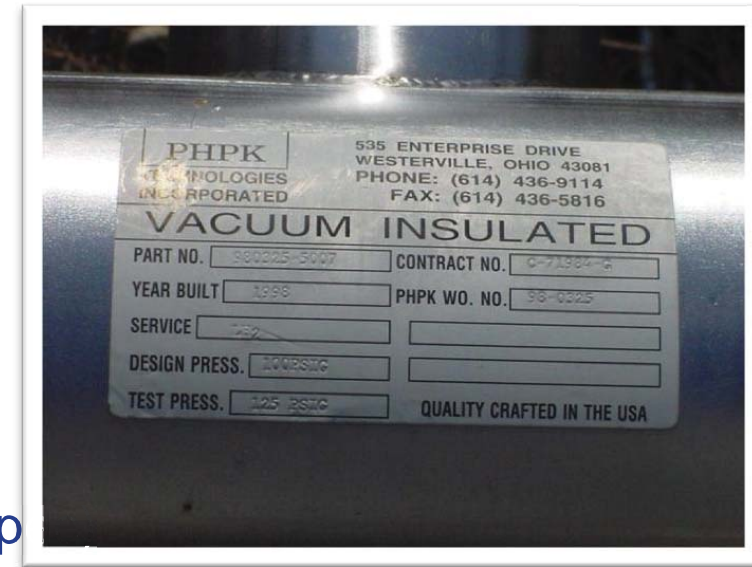

4" x 6" VJ LH2 Transfer Line w/Accessories

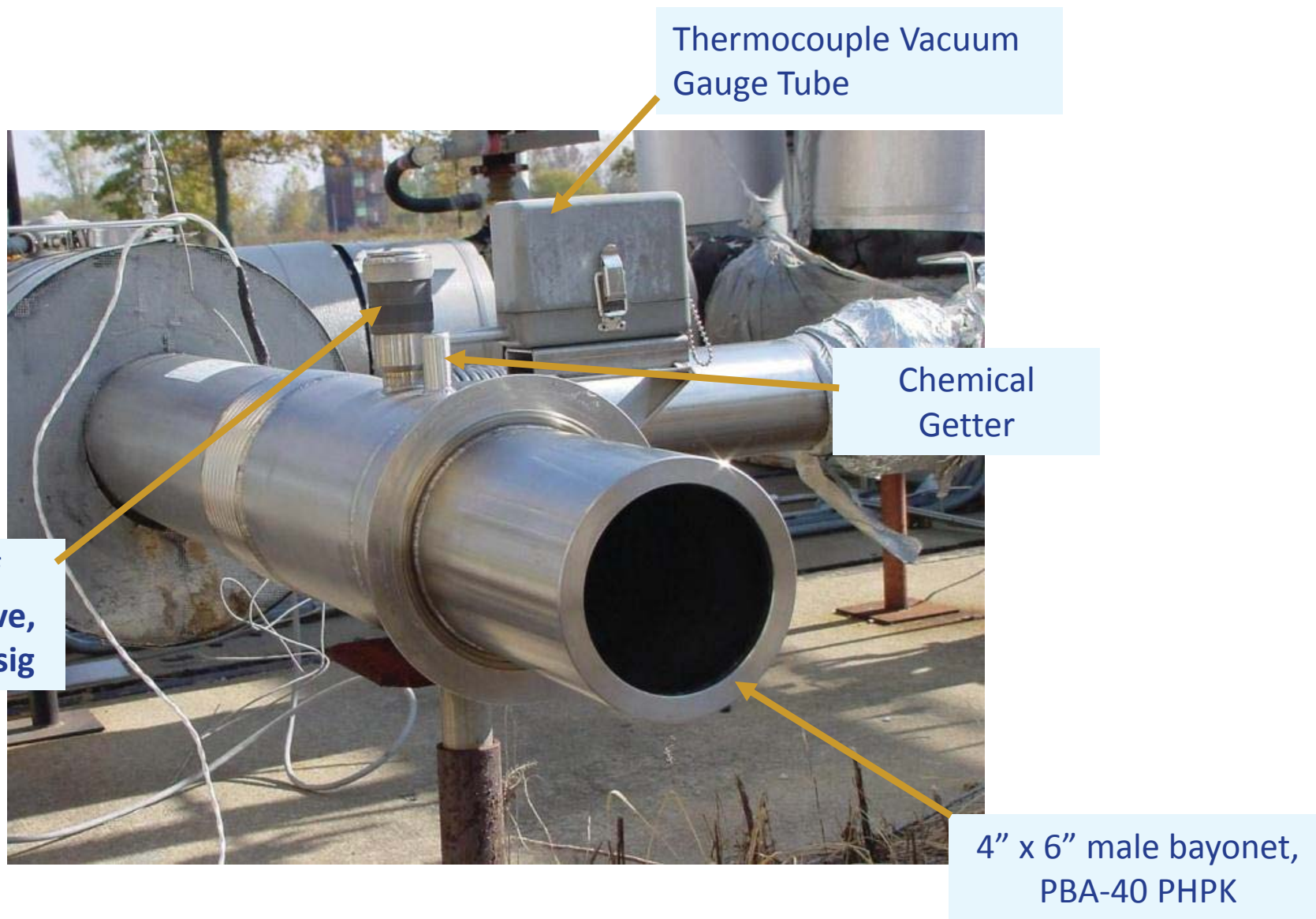

Thermocouple Vacuum Gauge Tube

Chemical Getter

Vacuum Seal-off pressure relief **valve**, VR-46, set @ 15 psig

4" x 6" male bayonet, PBA-40 PHPK



VJ Piping Heat Leak

HEAT LEAK in Btu/hr/ft and (Watts/ft)						
LINE SIZE	LN ₂		LO ₂		LH ₂	
	RIGID	FLEX	RIGID	FLEX	RIGID	FLEX
3/4" OD x 1-1/4" NPS	0.37 (0.11)	0.97 (0.28)	0.37 (0.11)	0.96 (0.28)	0.40 (0.12)	1.05 (0.31)
3/4" NPS x 2" NPS	0.43 (0.13)	1.21 (0.35)	0.42 (0.12)	1.19 (0.35)	0.46 (0.13)	1.29 (0.38)
1" NPS x 2-1/2" NPS	0.47 (0.14)	1.43 (0.42)	0.47 (0.14)	1.41 (0.41)	0.51 (0.15)	1.54 (0.45)
1-1/2" NPS x 3" NPS	0.58 (0.17)	1.74 (0.51)	0.57 (0.17)	1.71 (0.50)	0.63 (0.18)	1.89 (0.55)
2" NPS x 4" NPS	0.79 (0.23)	2.37 (0.70)	0.65 (0.19)	1.95 (0.57)	0.85 (0.25)	2.56 (0.75)
3" NPS x 5" NPS	0.98 (0.29)	2.95 (0.86)	0.84 (0.25)	2.52 (0.74)	1.08 (0.32)	3.24 (0.95)
4" NPS x 6" NPS	1.28 (0.38)	3.85 (1.13)	1.01 (0.30)	3.03 (0.89)	1.40 (0.41)	4.22 (1.24)
6" NPS x 8" NPS	1.65 (0.48)	4.97 (1.46)	1.36 (0.40)	4.10 (1.20)	1.83 (0.54)	5.50 (1.61)

- The table above reflects typical heat leak values for PHPK vacuum jacketed piping. These conservative values include components such as elbows, tees, etc., and are good for estimating total piping system heat leak. Components such as valves and bayonets should be added to establish an overall budget heat leak performance.

Source: <http://www.phpk.com/standard.html>

Piping, VJ Piping & Tubing Installs





Cryogenic Valves

- Extended Stem
 - Prevents freezing of stem packing
 - Reduces heat leak into process
- Vacuum Jacketed
- Low steady state heat leak
- Low mass (minimizes cool-down loss)
- Minimal resistance to flow (Low DP)
- Flow control characteristic
- Service: LHe, LH2, LN2, LO2, etc.
- Cost
- Valve Flow Capacity – Liquids

$$C_v = GPM \sqrt{\frac{sg}{\Delta P}}$$

- Valve Flow Capacity – Gases (Non-Choked)

$$C_v = \frac{w}{19.3 F_p P_1 Y} \sqrt{\frac{T_1 Z}{x M}}$$

$$Y = 1 - \frac{x}{3 F_k x_T} \quad x = \frac{\Delta p}{P_1}$$

CPC-CryoLab CV-8 Series
Cryogenic VJ Shut-Off Valve
300 psig WP, 1/2" - 4" NPS $C_v = 6.6 - 182$
Globe, straight, welded ends

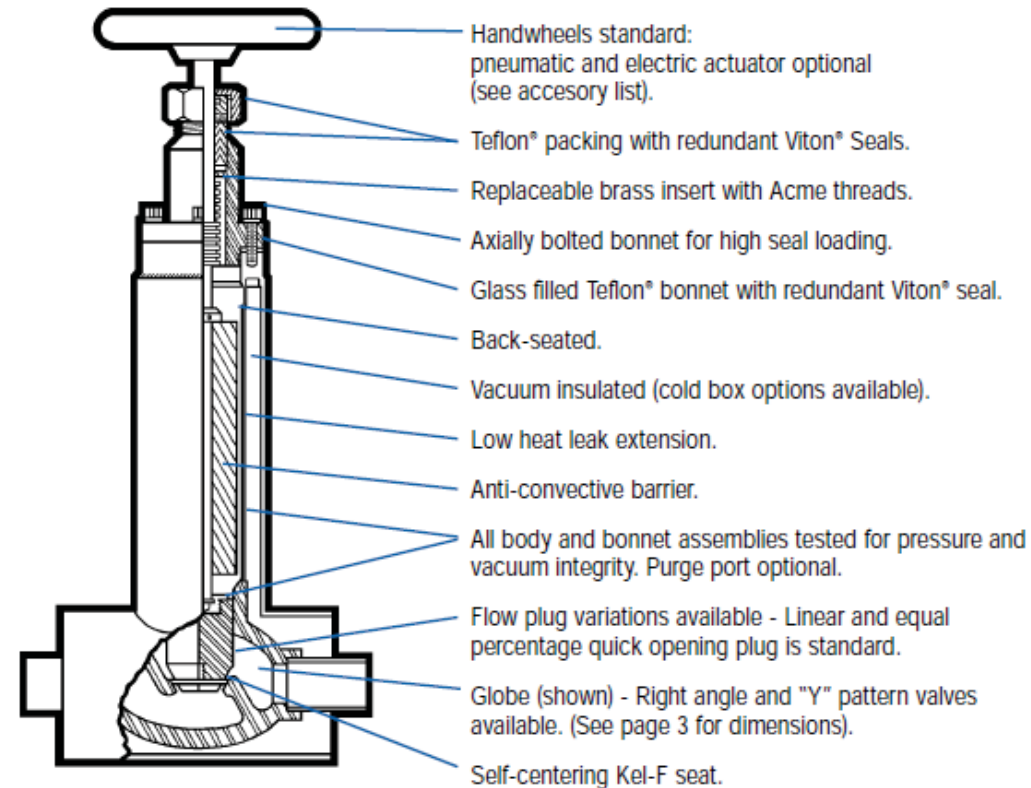



Cryogenic Valves

Technical Data

Operating Ranges

Temperature-456°F to +300°F
 -283°C to +149°C

Max. Operating Pressure 300 PSIG

Materials of Construction

All Major Structural Components are 300 Series Stainless Steel.

Body SeatKel-F

Bonnet GasketGlass Filled Teflon®

Redundant SealViton®

PackingTeflon® or Graphite

Tests

External LeakageMass spec. to
 1x10⁻⁹scc GHe/sec

Seat LeakageBubble Tight to 150 PSIG

Proof Pressure330 PSIG (ambient)

Valve Size

1/2" to 4"

Optional Accessories and Trim

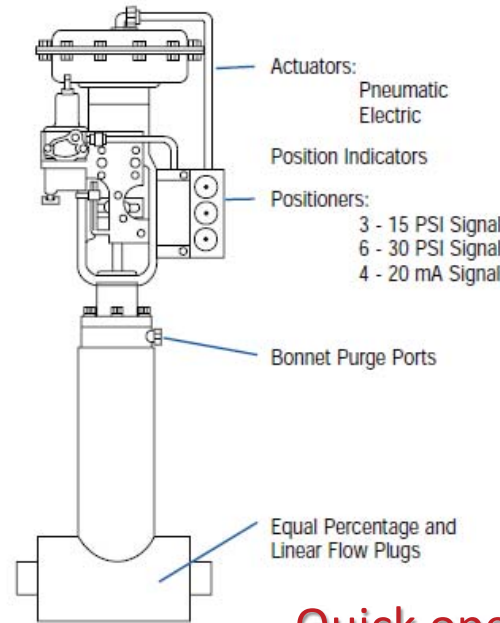

Actuators, Accessories, and Trim Hardware must be specified when an automatic valve is ordered.

General Information needed:

- Maximum Working Pressure
- Available Air Supply Pressure
- Signal Input to Valve
 - 3 - 15 PSI
 - 6 - 30 PSI
 - 20 - 60 PSI
 - 4 - 20 mAmp.
- Flow Rate in SCFM or GPM
- Fluid Media
- Working Temperature
- Air to Open or Air to Close

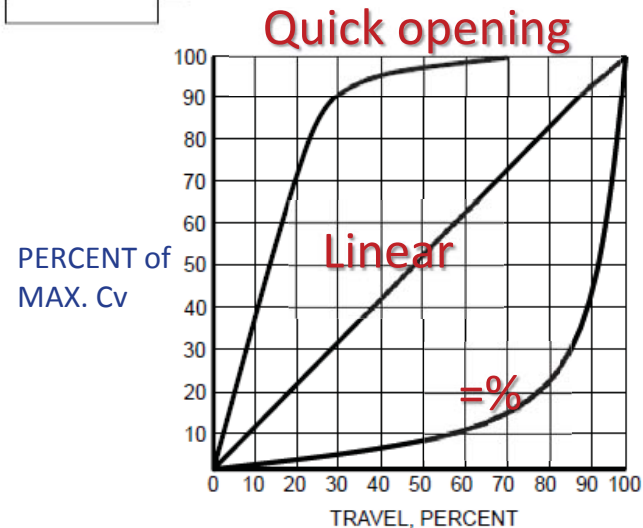

Cryogenic Valves



Cryogenic NC LH2 Solenoid Valve



REFERENCES

Hutchison, J.W., ISA Handbook of Control Valves, 2nd Ed. Research Triangle Park, NC: Instrument Society of America, 1976.
Control Valve Handbook, 4th ed. Fisher Controls, 2005, Ch. 5.
ANSI/ISA-75.01.01-2002, Flow Equations for Sizing Control Valves

Instrumentation & Controls

- Remote control of facility required when testing with flammable cryogenics – LH_2 , LCH_4
- Remote control of facility typically implemented using remotely actuated valves & controls via a computer controlled interface
 - Programmable Logic Controller (PLC) with Wonderware MMI
- When testing with LO_2 or LN_2 , tests can be conducted locally using manual controls (hand valves)

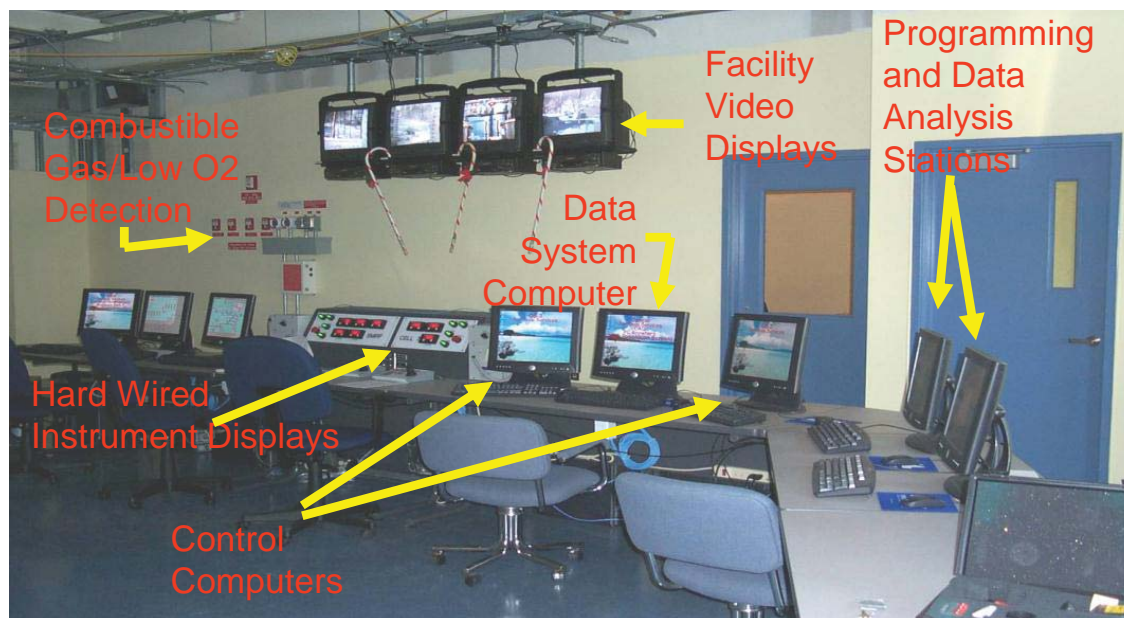

SMIRF Facility Controls

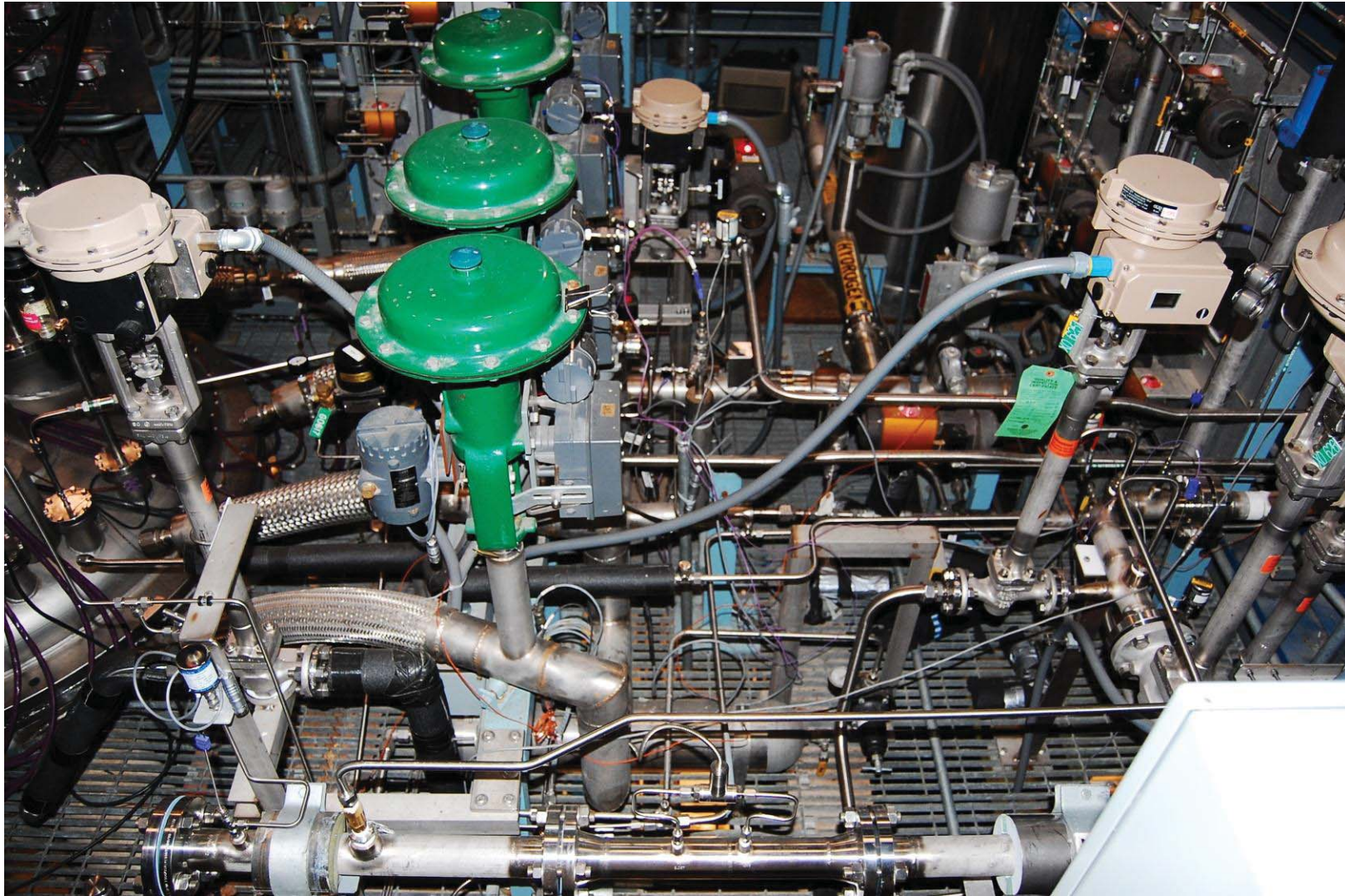



Cryogenic Instrumentation

- Most cryogenic component and system tests need the following data:
 - Temperature – fluid and hardware temperatures
 - Pressure – system pressures
 - Flow – either flow of liquid or gas
 - Power – either heaters or pump/mixer motors
 - Level – elevation of a fluid inside a tank



Temperature – Range of Cryogenic Thermometers



Chromel-constantan
Type E thermocouple

Au-Fe thermocouple



Pt resistance

Rh-Fe resistance



Silicon Diodes

Allen-Bradley carbon
resistance



RTD Cernox

Ge resistance

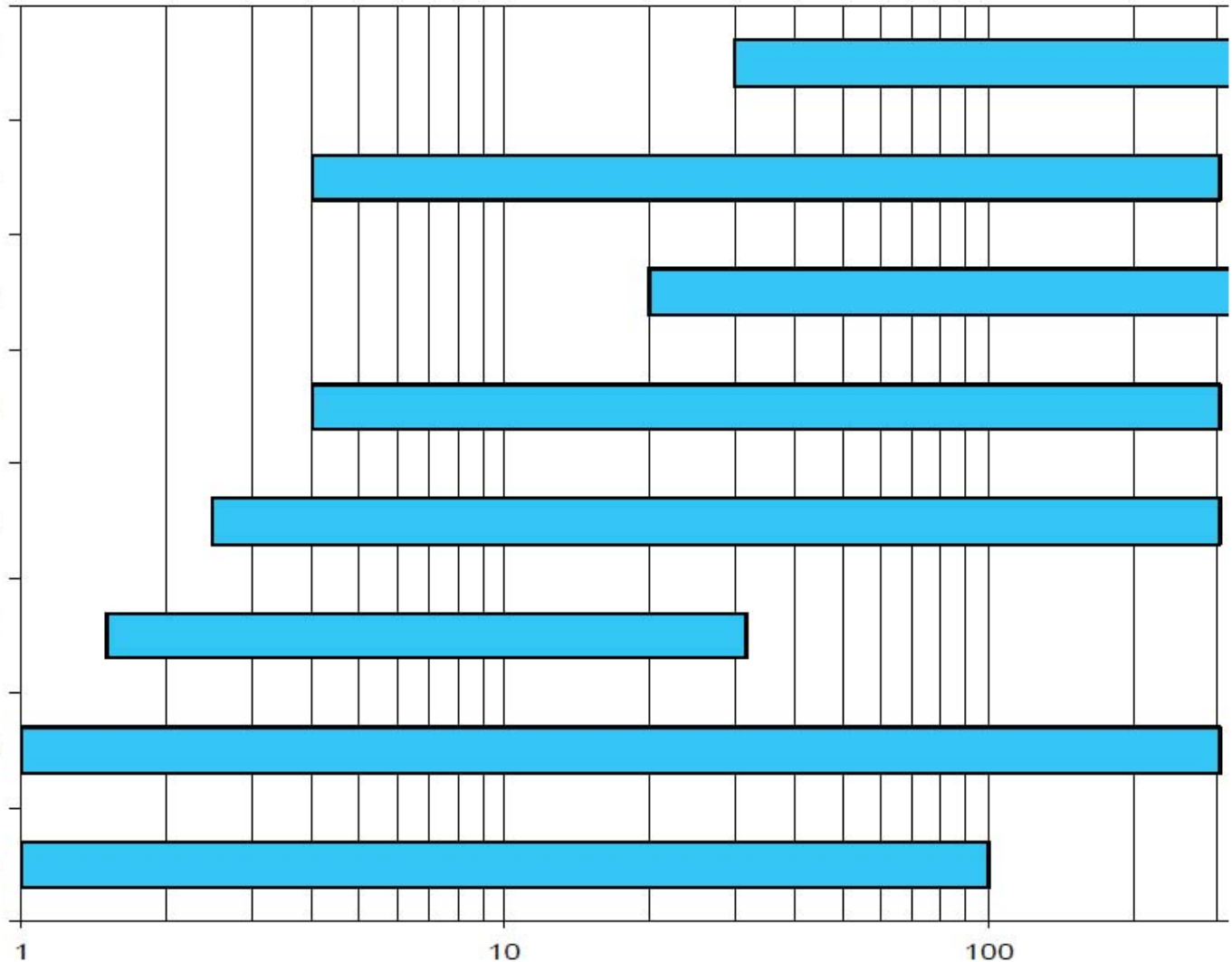

Sensors most commonly used in practice

Temperature [K]

Temperature Measurement

- Thermocouples – Type “T”, “E”, “K” TCs work at cryogenic temperatures (~73K/132 deg R)
- Lower temperatures (~20K/39 deg R) must be measured with Silicon Diodes or RTD temperature sensors
- Si Diodes are more accurate than TCs
 - Si Diode accuracy = ± 0.25 K to ± 0.50 K
 - TC accuracy = ± 1.0 K to ± 2.0 K
 - Si D best choice for general purpose cryogenics
- Resistance Temperature Detector (RTD)
 - FSR = 0.1 K – 300 K
 - RTD accuracy = ± 0.01 K @ 10 – 77 K

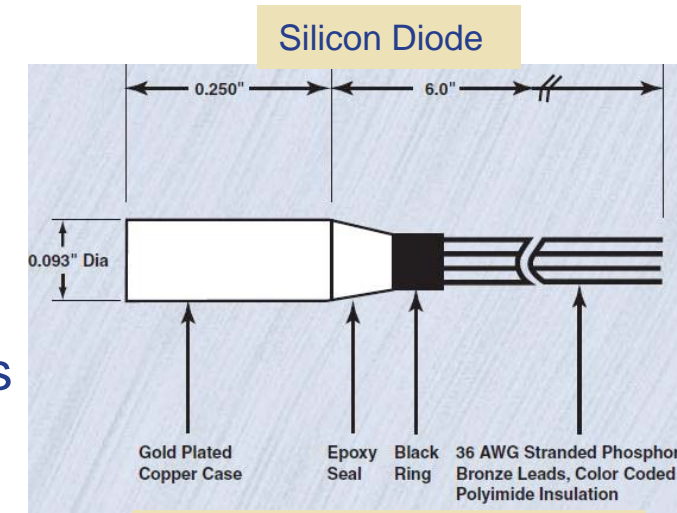

Picture – Scientific Instruments



Pictures - Lake Shore Cryotronics





Thermocouples

Common Thermocouple Temperature Ranges			
Calibration	Temp Range	Std. Limits of Error	Spec. Limits of Error
J	0°C to 750°C (32°F to 1382°F)	Greater of 2.2°C or 0.75%	Greater of 1.1°C or 0.4%
K	-200°C to 1250°C (-328°F to 2282°F)	Greater of 2.2°C or 0.75%	Greater of 1.1°C or 0.4%
E	-200°C to 900°C (-328°F to 1652°F)	Greater of 1.7°C or 0.5%	Greater of 1.0°C or 0.4%
T	-250°C to 350°C (-328°F to 662°F)	Greater of 1.0°C or 0.75%	Greater of 0.5°C or 0.4%



A thermocouple consists of two dissimilar metals, joined together at one end. When the junction of the two metals is heated or cooled a voltage is produced that can be correlated back to the temperature.

Revised Thermocouple Reference Tables

TYPE T

Reference Tables
N.I.S.T.
Monograph 175
Revised to
ITS-90

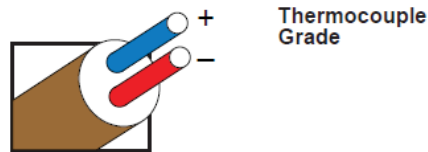

Thermocouple Grade

Copper
VS.
Copper-Nickel



Extension Grade

MAXIMUM TEMPERATURE RANGE

Thermocouple Grade

- 328 to 662°F
- 200 to 350°C

Extension Grade

- 76 to 212°F
- 60 to 100°C

LIMITS OF ERROR

(whichever is greater)

- Standard:** 1.0°C or 0.75% Above 0°C
- 1.0°C or 1.5% Below 0°C
- Special:** 0.5°C or 0.4%

COMMENTS, BARE WIRE ENVIRONMENT:

Mild Oxidizing, Reducing Vacuum or Inert; Good Where Moisture Is Present; Low Temperature and Cryogenic Applications

TEMPERATURE IN DEGREES °C
REFERENCE JUNCTION AT 0°C

Pressure Measurement

- Capacitance type transducer – multiple ranges absolute pressure and differential pressure available, accuracy $\pm 0.11\%$ F.S.
- Strain Gauge Transducers can also be used, but are not as accurate ($\pm 0.5\%$ F.S.) and require signal conditioning
- Standard Pressure Gauges can be used for local system pressure monitoring
- Pressure sensors typically operate at ambient temperature with a pressure sensing tube interfacing with the cryogenic system

Capacitance Pressure
Transducer



Setra Pressure Measurement Division



Ashcroft

Flow Measurement

- Fluid flow can be measured either as a cryogenic liquid, or as a vaporized gas
- Liquid flow meters:
 - Turbine Meters
 - Orifice or Venturi meters
- Gas flow meters
 - Turbine Meters
 - Orifice or Venturi meters
 - Mass Flow Meters
- Other indirect methods of measuring flow
 - Liquid level measurement
 - Load Cells

Turbine flow meter



Hoffer Flow Instruments

Hastings 200 series mass flow meter



Teledyne-Hastings Instruments

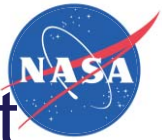

Vendors of Cryogenic Instrumentation – a Short List

Temperature

- Silicone diodes (DT-470-SD-13)
 - Lakeshore Cryotronics
- Model Si-410 Silicon diodes
 - Scientific Instruments
- Resistance Temperature Detector (RTD)
 - Lakeshore Cryotronics (RF-800)
- Type “E”, “T”, “K” Thermocouples
 - Omega

Pressure

- Capacitance type PT's
 - Setra (*economic*)
- Piezo-resistive strain gage
 - Fisher Rosemount (*expensive*)
 - 2088 series
 - Variable range, HART

Liquid Level

- Capacitance liquid level sensor
 - American Magnetics

Flow Rate

- Orifice Flow Meters (ASME design)
- Turbine Flow Meters
 - Hoffer Flow Controls
- Venturi Flow Meters
 - Flow-Dyne Engineering
- Coriolis Mass Flow Meters
 - Micro-Motion
- Annubar Pitot Static Probe
 - Deiterich Standard

Vacuum

- Hastings Vacuum Gages

Overview of what the author has successfully used on cryogenics projects in liquid and low temperature gas service



Instrumentation Uncertainty

- Uncertainty of measurement is the doubt that exists about the result of any measurement.
- Effects that give rise to uncertainty in measurement are both:
 - Random
 - Systematic
- The uncertainty of a measurement tells us something about its quality
- Estimating the quality of a measurement and calculating the uncertainty involves the following steps:
 - Identify the relevant sources of measurement uncertainty
 - Estimate the magnitude of the uncertainty from each source
 - Express the source standard uncertainties in consistent units
 - Combine the individual uncertainties to give an overall value

$$u_c = \sqrt{u_1^2 + u_2^2 + u_3^2 + \dots + u_n^2}$$

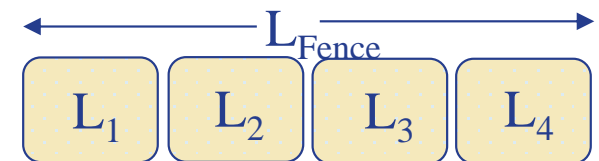

where u_c is the combined standard uncertainty arising from several independent uncertainty sources “ u_i ” – thru “ u_n ”



Uncertainty Analysis Examples

- For complicated cases, the uncertainty is often calculated in terms of relative or fractional uncertainties u_y/y

1a. Surface area of a rectangular part

$$A = L \times W$$

1b Relative combined uncertainty in area

$$\frac{u_A}{A} = \sqrt{\left(\frac{u_L}{L}\right)^2 + \left(\frac{u_W}{W}\right)^2}$$

2a. Power from voltage & resistance

$$P = \frac{V^2}{R}$$

2b Relative combined uncertainty in power

$$\frac{u_P}{P} = \sqrt{\left(\frac{2u_V}{V}\right)^2 + \left(\frac{u_R}{R}\right)^2}$$

3a. Venturi mass flow from ΔP and ρ

$$q = \frac{C}{\sqrt{1 - \beta^4}} \epsilon \frac{\pi}{4} d^2 \sqrt{2 \Delta P \rho_1}$$

3b Relative combined uncertainty in q

$$\frac{u_q}{q} = \sqrt{\left(\frac{u_{\Delta P}}{\Delta P}\right)^2 + \left(\frac{u_\rho}{\rho}\right)^2}$$

4a. Penetration heat leak from Q and h_{fg} out

$$Q_{Strut} = \frac{k A \Delta T}{x}$$

$$Q_{Meas} = Q_{MLI} = \rho h_{fg} V$$

$$Q_{Pen} = Q_{Meas} - Q_{MLI} - Q_{Strut}$$

4b Relative combined uncertainty in Q_{Pen}

$$u_{\Delta Q_{Pen}} = \sqrt{\left(\frac{kA\Delta T}{x}\right)^2 \left[\left(\frac{u_k}{k}\right)^2 + \left(\frac{u_A}{A}\right)^2 + \left(\frac{u_{\Delta T}}{\Delta T}\right)^2 + \left(\frac{u_x}{x}\right)^2 \right] + 2(\rho h_{fg} V)^2 \left[\left(\frac{u_V}{V}\right)^2 + \left(\frac{u_\rho}{\rho}\right)^2 + \left(\frac{u_{h_{fg}}}{h_{fg}}\right)^2 \right]}$$

Materials for Cryogenic Testing

Use materials which do not become brittle (loss in ductility) at low temperature

- FCC – good
 - Stainless Steels (> 7% Ni)
 - Aluminums & AL Alloys
 - Coppers
 - Nickels
 - Copper-nickel alloys
 - PTFE
- BCC – bad
 - Iron
 - Carbon & low alloy Steels
 - Niobium / Molybdenum
- HCP – maybe
 - Zinc (bad)
 - Zirconium (good)
 - Titanium (good, but not H₂)

Face Center Cubic (FCC)

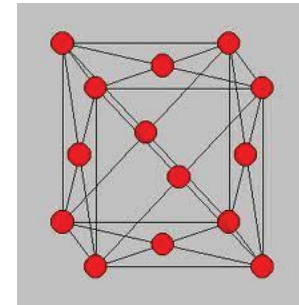

Body Center Cubic (BCC)

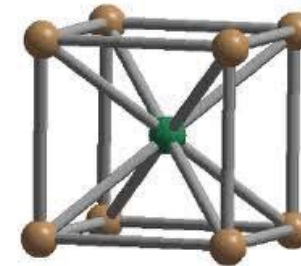

Hexagonal Closed Packed (HCP)

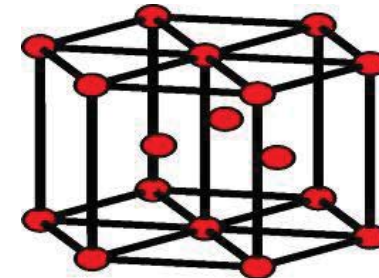



Materials for Cryogenics – Selection Criteria

- Mechanical Properties
 - Yield strength (S_y)
 - Tensile strength (S_u)
 - Modulus of Elasticity (E)
 - Density (ρ)
- Thermal Properties
 - ☺ Heat capacity (c_p)
 - ☺ Conductivity (k)
 - ☺ Thermal expansion coefficient (α)
- Surface Properties
 - ☺ Emissivity (ϵ)
 - Corrosion resistance (C_r)
- Electrical Properties
 - Resistivity (R)
 - Magnetic / Non-Magnetic (β)
- Working Properties
 - Welding
 - Forming
 - Extrusion
- Other Criteria
 - Cost (\$)
 - Availability

Material References: Cryogenic Materials Data Handbook, AFML-TDR-64-280, July 1970.

NIST Website: <http://cryogenics.nist.gov/MPropsMAY/materialproperties.htm>



Material Selection Considerations

- Test hardware design must consider:
 - Low temperatures – materials must be compatible with cryogenic temperatures
 - Metals that don't have a brittle transition (i.e. – stainless steels, copper & bronze alloys, aluminum)
 - Seals that maintain their plasticity at cryo temperatures (teflon, Kel-F)
 - Non-metals rated for low temperatures (some composite materials, G-10 micarta)
- What cryo fluid they will operate in
 - LO2 testing requires cleaning for oxygen service (ASTM cleaning standard ASTM G-93)
 - Oxygen compatibility – verify materials can be used in oxygen service – high oxygen concentration promotes combustion (reference NASA report TM X-04711 for list of compatible materials)
 - LH2 test temperatures are much colder than other cryogenes we typically test with.
 - *“Hardware that works at 77K may not work at 20K” (John Jurns, 2010)*
- Dissimilar materials
 - Methods for joining dissimilar materials (eg. Aluminum/Stainless Steel)
 - Coefficient of thermal expansion –mismatch in α can cause stress problems!



Heat Capacity

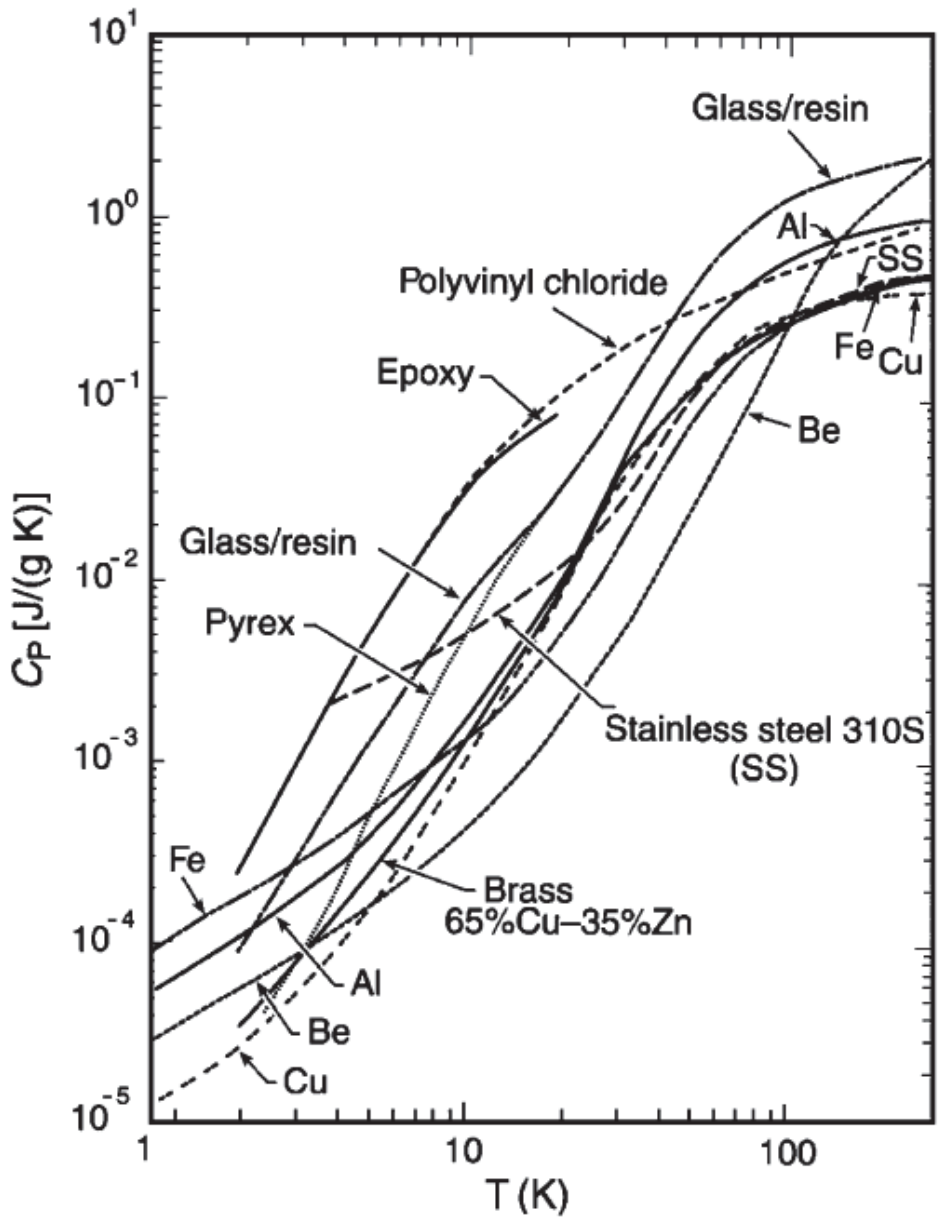

Specific heat capacity of technical materials used in cryogenics. Value of C_p affects chill down energy of a metal mass to a cryogenic temperature

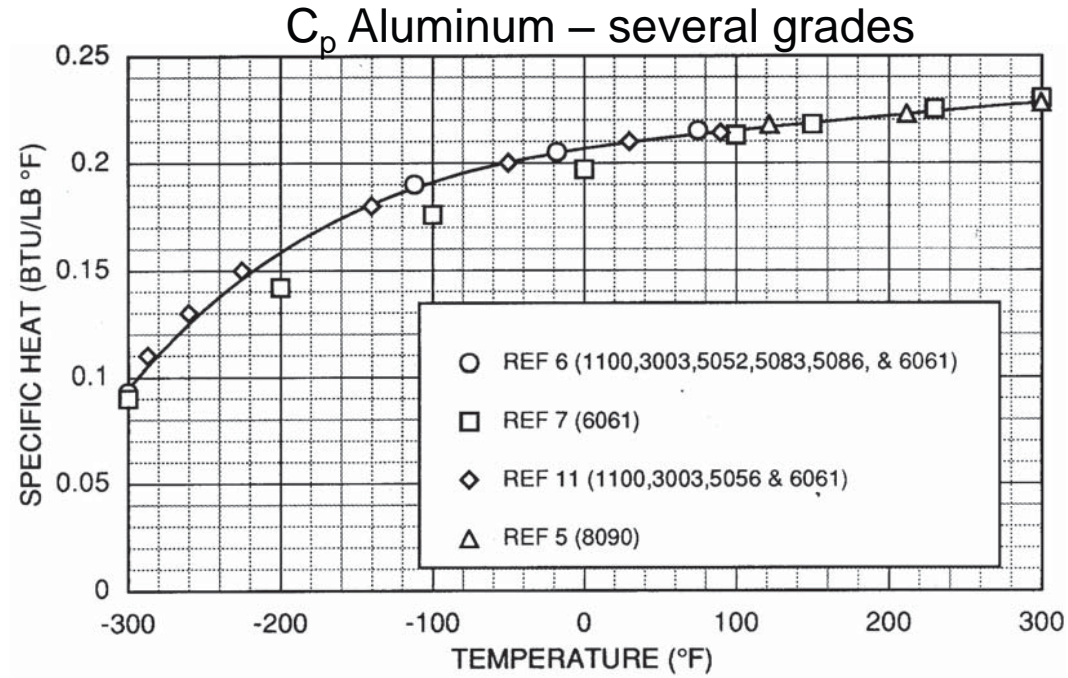
$$dQ = M C_p(T) dT$$

Ref: J. W. Ekin, Experimental Techniques for Low Temperature Measurements, Oxford University Press, Oxford, 2006.

Thermal Conductivity

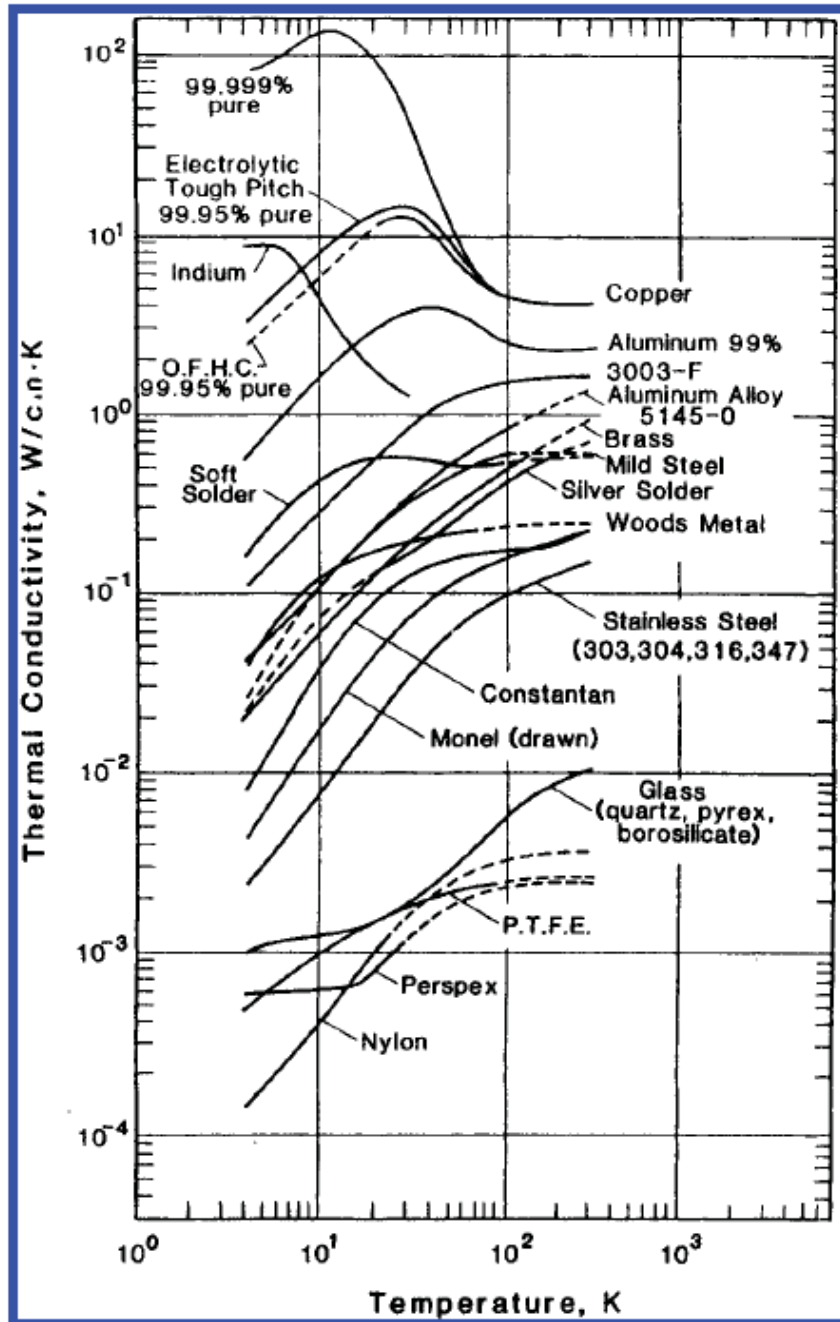

Thermal conductivity is a material property that determines the temperature gradient across a substance in the presence of a conductive heat flow. Thermal conductivity (k) impacts the amount of heat transfer into cryogenic systems (**Not Good**)

$$\dot{q} = -A k(T) \frac{dT}{dX}$$

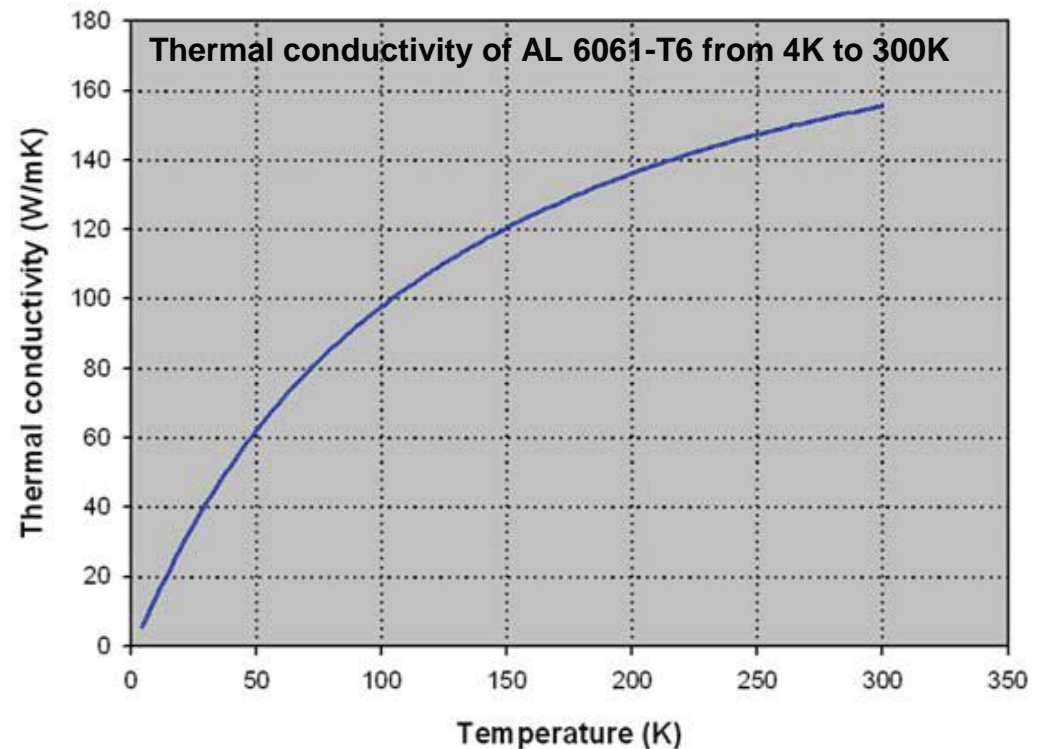

<http://cryogenics.nist.gov/MPropsMAY/material%20properties.htm>



Thermal Expansion

- Materials expand and contract with large temperature swings
 - Sometimes referred to as α , coefficient of thermal expansion
 - For solids $\alpha = \left(\frac{\Delta L}{\Delta T} \right) \frac{1}{L}$
 - Often presented as % linear expansion
 - Very non-linear at low temperatures
- Most of it occurs above 77 K
- Can induce large amounts of stress on welds and joints
- Most often present in long lengths of piping and vacuum jacketed piping



Thermal Expansion of Several Metals

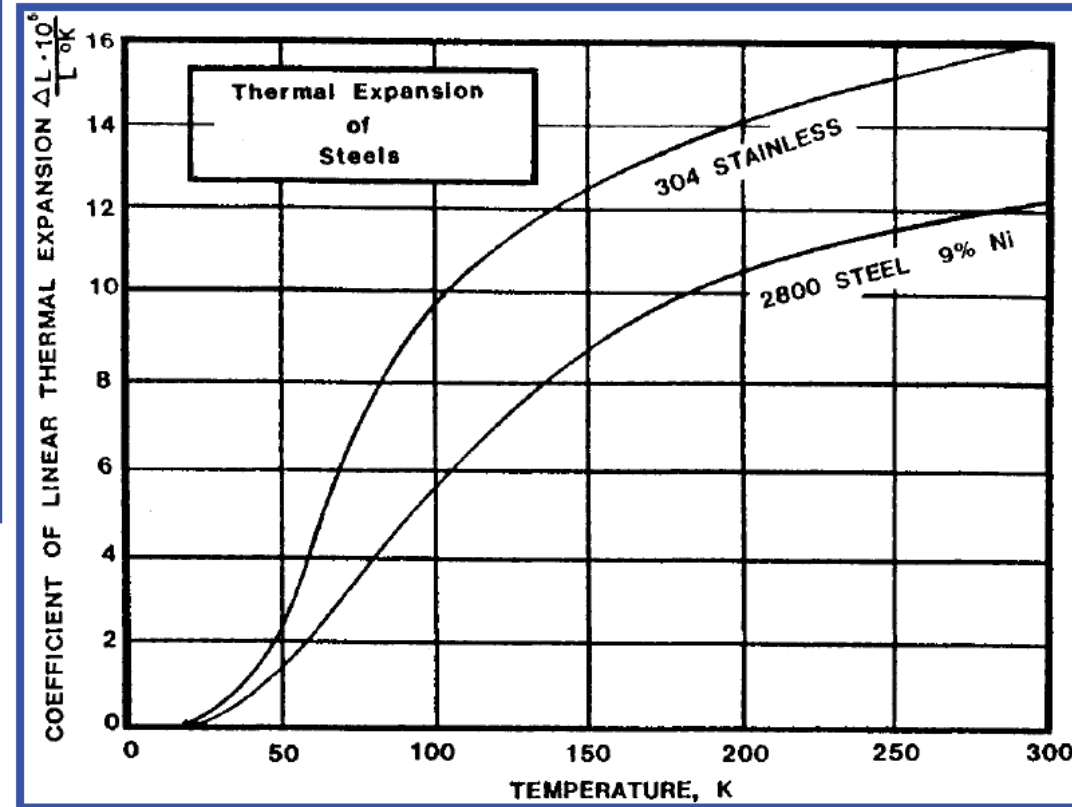
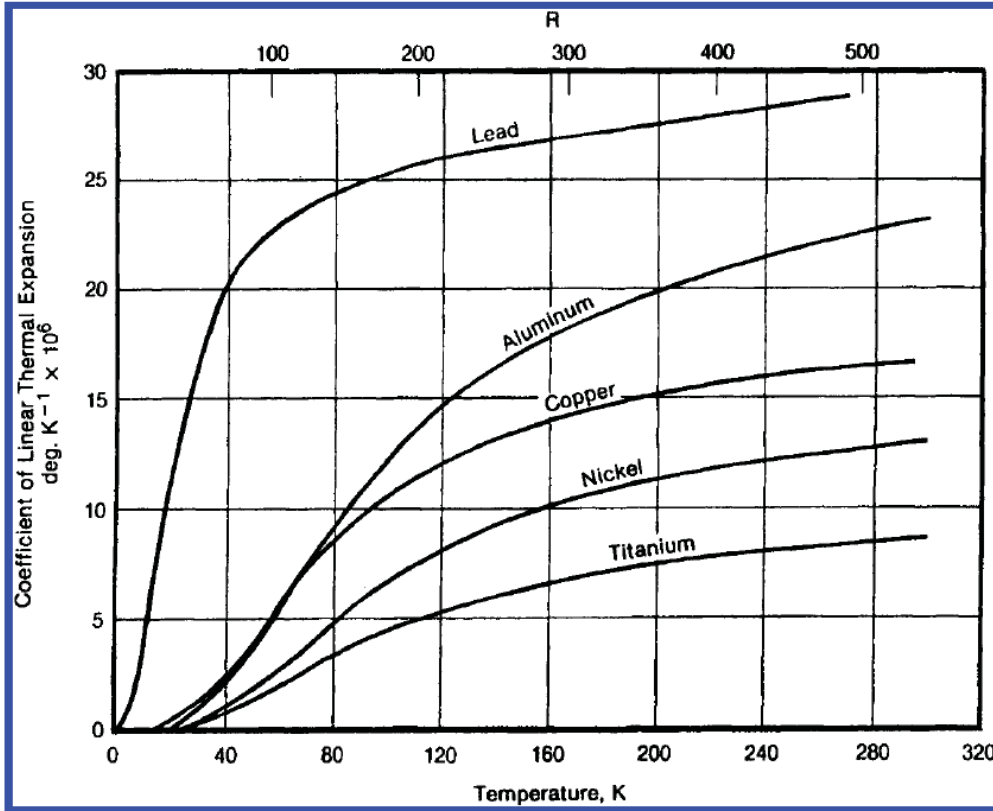

Thermal Expansion Example





Emissivity

Emissivity (ϵ): The ratio of the actual amount of electromagnetic radiation emitted by an object to the amount emitted by an ideal blackbody at the same temperature. The emissivity of like materials varies with wavelength, temperature and the condition of the surface

Rules of thumbs for emissivity:

- Materials having low emissivity also have low electrical resistance
- Emissivity decreases with decreasing temperature
- The apparent emissivity is increased by surface contamination
- By alloying a metal, emissivity increases
- By mechanical polishing the metal surface, emissivity increases
- Metal emissivity's are in the range of:
 - 0.02 – 0.6 for copper
 - 0.02 – 0.3 for aluminum
 - 0.05 – 0.1 for stainless steel

Material	ϵ (300 K)	ϵ (77 K)
Al, annealed, electropolished	0.03	0.018
Aluminum Foil (household)	—	0.043
Brass, 65 Cu/35 Zn	0.35	0.029
Copper, polished	0.03	0.019
Copper, black oxidized	0.78	—
Stainless steel, 18-8	0.08	0.048
Electroplate silver (Ag polish)	0.017	0.0083
Titanium sheet, smooth rolled	0.13	—

T. Flynn, Cryogenic Engineering, 1997



Design

- Test specific hardware (often one of a kind) may be:
 - Fabricated in-house
 - Obtained from other organizations
 - Procured from specialty manufacturers

Integration

- Interfaces
 - Fluid interfaces – liquid & gas
 - Flexible connections – good, but introduce additional pressure drop
 - Avoid traps in piping design
 - Structural support – structural design should minimize heat conduction path from surroundings to test article
 - Long, thin supports to minimize solid conduction
 - Low conductivity material structural supports
 - Instrumentation/control interfaces
 - Instrument wiring feed thru's – hermetic seals, packed seals
 - Power feed thru's – keep separate from instrument wiring
 - Video recording



Test Hardware – Interfaces & Supports

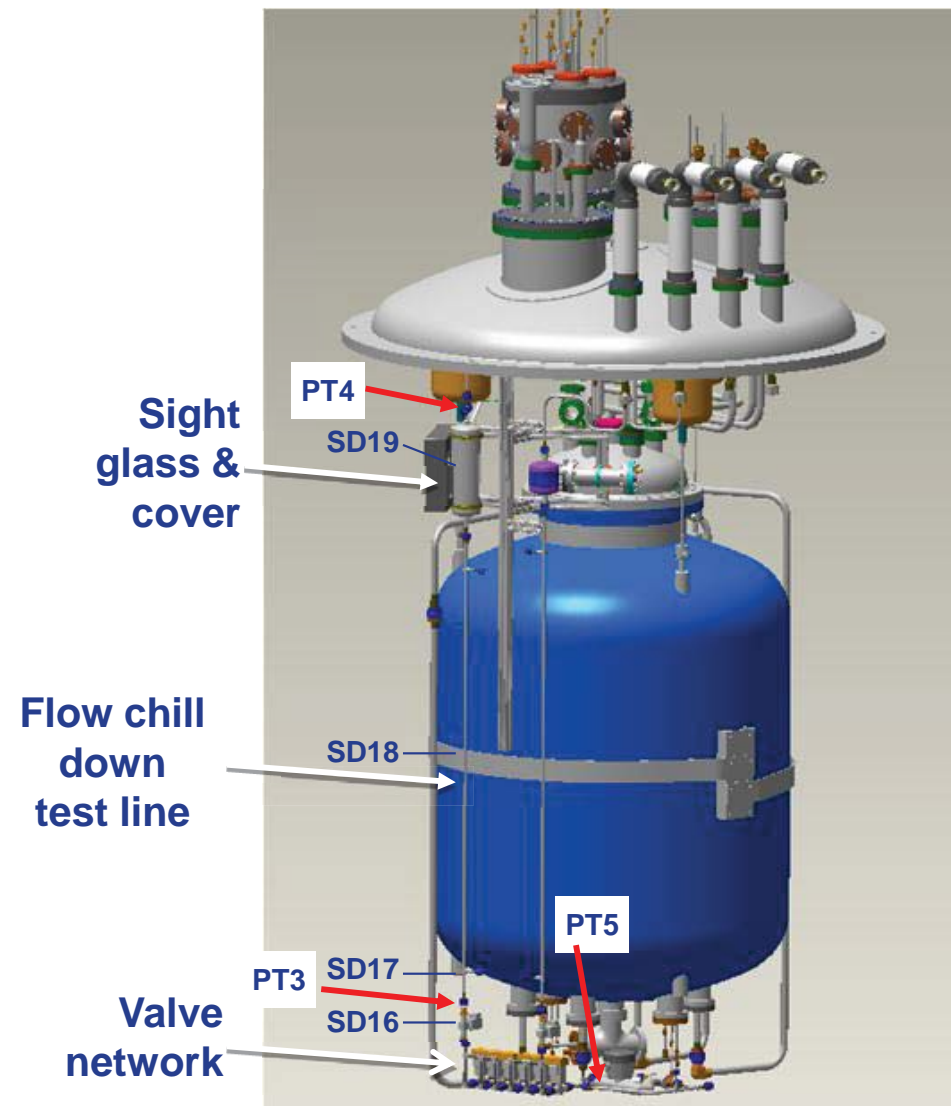

Test Hardware

Two-Phase Cryogenic Heat Exchanger
for Thermodynamic Vent System – LOX
ZBO Test at GRC

MLI Passive Thermal Control of
LCH4 Propellant Tank – MLSTC Test
at GRC (MLI mfg. Ball)

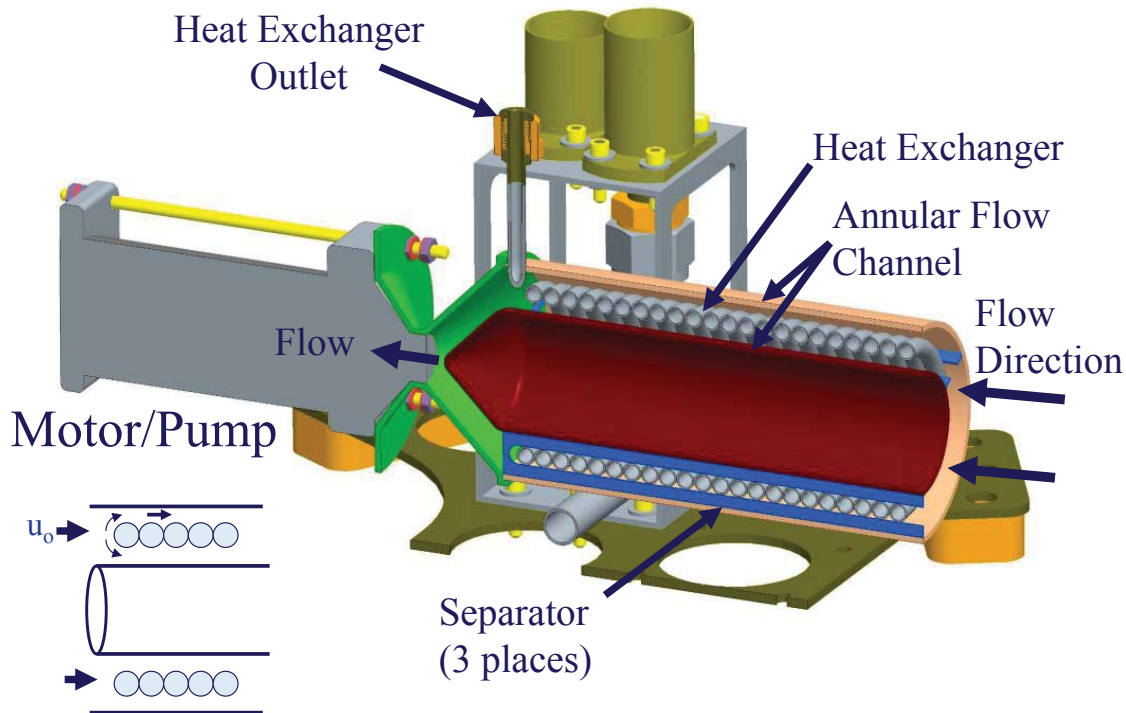

Test Hardware – A Very Large and Complex Integration





Pressure Systems Overview

NASA-STD-8719.17 NASA Requirements for Ground-Based Pressure Vessels and Pressurized Systems (PVS) requires that all pressure systems be certified in accordance with applicable national standards such as:

- ASME Boiler & Pressure Vessel Code
- ASME B31.3 Piping
- Compressed Gas Association (CGA) standards
- National Fire Prevention Ass'n (NFPA)
- Department of Transportation (DOT)



Exceptions – Test article PVS that have been formally reviewed and accepted in accordance with the requirements of NPR 8715.3, NASA General Safety Program Requirements, are excluded. Exceptions are granted after review of a formal exclusion request





Cryogenic Pressure Systems

- Piping must be designed to B31.3 and a flexibility analysis must be performed
 - Thermal contraction of piping can lead to high stress
 - Piping must be cold shocked as well as hydro-tested
- Pressure vessels must be designed to ASME Code (except for flight systems)
- Relief valves must be installed to prevent fluid being blocked between 2 valves
- Ball valves should have vented balls that prevent fluid trapped inside the ball
- Vacuum jacketed piping and vessels must have relief. CGA S1.3 provides guidance on jacket relief valve devices



Pressure Systems Certification

- NASA Pressure Systems Office (PSO) will review the design and analysis documentation as part of code compliance and certification process of the Cryogenic Pressure Systems to be tested
 - a. P&ID of the system
 - b. System component sheet
 - c. Data sheets for relief devices, pressure regulators, pressure vessels, heat exchangers, Dewars, etc.
 - d. Design calculations
 - e. Relief device calculations verifying set points and flow capacities
 - f. Relief device certification test reports
 - g. System piping design, fabrication, inspection, and test information
 - i. Construction, installation, and/or fabrication drawings
 - ii. Design calculations and specifications
 - iii. Mill test reports or material specifications
 - iv. Inspection and NDE reports
 - v. Hydrostatic or Pneumatic pressure test reports
 - vi. Weld documentation (WPS, PQR, and WPQ)

Pressure Systems Domain



PSO
PRESSURE SYSTEMS SAFETY
PRESSURE SYSTEMS OFFICE

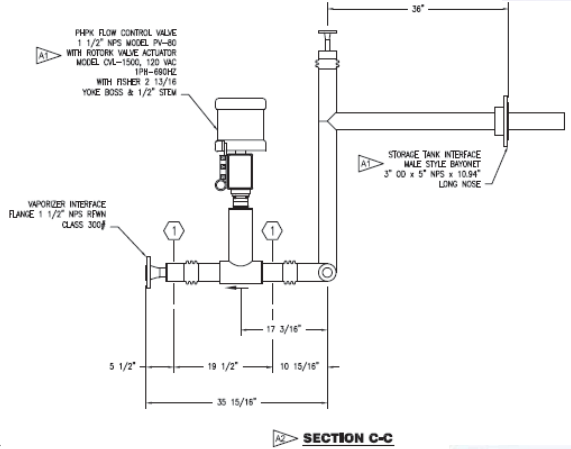

Relief Valve Sizing

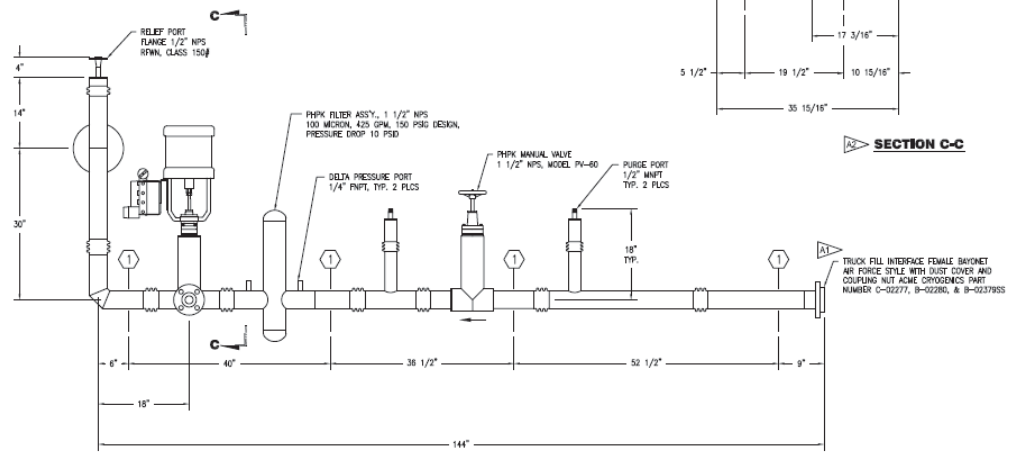
$$A = \frac{W \sqrt{T Z}}{C K P_1 K_b \sqrt{MW}}$$



Safety

- At NASA Glenn, safety requirements must be met and an official NASA safety permit issued prior to start of any testing
 - GRC is divided into specific geographical areas. Test facilities in each area fall under the oversight of Area Safety Committees.
 - These committees are staffed by volunteers that have expertise in the various aspects of tests and facilities. The Area Safety Committees are the final arbiters of when a test facility is safe to operate. The committee issues a safety permit based on:
 - Review of a safety permit request package
 - Formal safety review
 - Facility walkthrough
 - NASA Glenn Safety Manual GLM–QS–1700.1 provides details on:
 - Safety Permit Process – chapter 1A
 - Hydrogen Safety – chapter 6
 - Oxygen Safety – chapter 5
 - Pressure Systems Safety – chapter 7



Typical Cryogenic Hazards

- Cryogenic burns – don't touch cold pipes
- Asphyxiation – loss of atmosphere due to vaporizing liquid
- Thermal contraction – improperly supported equipment can contract when cold and break
- Over pressurization – vaporizing liquids need appropriate pressure relief
- Oxygen compatibility & cleanliness – improper materials or equipment not cleaned of hydrocarbons can burn in an enriched oxygen atmosphere
- Oxygen enrichment – cryogenic fluids with boiling points lower than oxygen can preferentially liquefy oxygen out of the atmosphere if not properly insulated.



Safety Considerations

- Explosion/deflagration – type & quantity of fluid determine hazardous radius that must be isolated (quantity/distance calculations)
- Venting – flammable gasses (hydrogen & methane). Need to determine dispersion patterns & how to safely vent. Note that some cold gasses are denser than air and may settle close to ground
 - CGA G-5.5 – Hydrogen Vent Systems
- Spills – Require safety measures to contain possible spills depending on fluid (LH₂ will disperse, but LCH₄ may pool and must be contained)

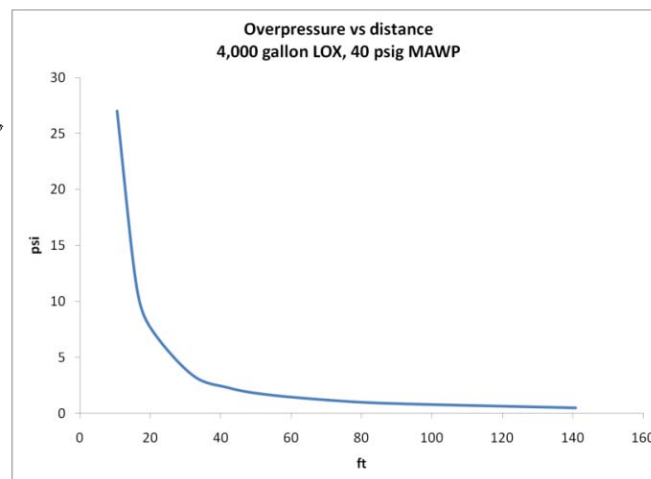
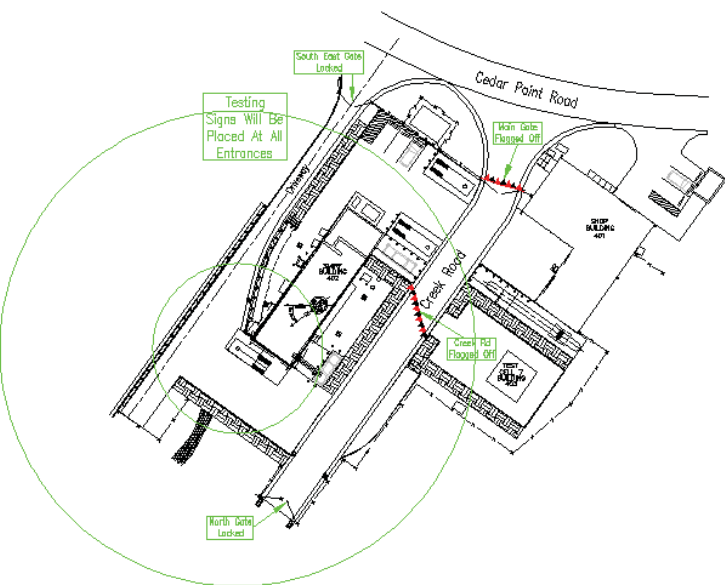



H2 Code Considerations

- The GSM Chapter 6 – Hydrogen provides guidance on H2 safety aspects that must be included during design & testing
 - Material properties, Handling, Policies, Responsibilities and Requirements
- NFPA 55 (*Compressed Gases and Cryogenic Fluids Code*) is the industrial standard for handling and storage of H2. Storage areas at GRC are usually covered by this code
- NASA STD 8719.12 (supersedes NSS 1740.12) provides NASA regulations for LH2 test facilities
 - Terms: explosive equivalence, Quantity Distance Relationship, Protected & Unprotected distance
 - Explosive equivalence is calculated by $8W^{2/3}$ or $0.14W$ where W = weight of LH2/LO2
- Other references: ANSI/AIAA G-095-2004, *Guide to Safety of Hydrogen and Hydrogen Systems*



Electrical Safety H2

- Why are mechanical engineers concerned about electrical issues?
- H2 has very wide flammability limits and component choice drives additional design requirements
 - Lower Flammability Limit H2 LFL = 4.1 % in air
 - Upper Flammability Limit H2 UFL = 74.8% in air
 - Have to make sure components are specified for the proper environment
 - Have to understand the cost/design implications with choosing certain instruments



Electrical Safety H2

- H2 is considered a Class 1, Div. 2, Group B fluid per National Electric Code (NEC – NFPA 70)
 - Division 1 – H2 is normally present in the atmosphere (vent)
 - Division 2 – H2 is only present in the atmosphere in the event of an off nominal condition (leak)
- NFPA 497 provides recommended practice for classification for electrical installation
 - 3' around make/break connections = D1
 - 25' around make/break connections = D2



Electrical Safety H2

- Components can be selected to be Class 1, Div 1 (or 2) Group B
 - Intrinsically safe
 - Not enough energy to form a spark
 - Explosion proof
- Non-rated components must be installed in a pressurized or purge box
 - NFPA 496 – Standard for Purged & Pressurized Enclosures for Electrical Equipment
- Some items such as motor the are TEFC brushless motors are allowed in Class 1, Div. 2 locations even if they are not UL certified for that area (NEC 501.125 (B))



LO2 Code Considerations

- The GSM Chapter 5 provides guidance on oxygen safety aspects that must be included during design & testing
 - Material properties, Prohibited materials, Handling, Policies, Responsibilities and Requirements
- NFPA 55 is the industrial standard for handling and storage of O₂. Storage areas at GRC are usually covered by this code
- NASA STD 8719.12 provides NASA regulations for LO₂ test facilities especially when fuels are also present
- Others
 - Chapter 4 of ASTM MNL36
 - ASTM G88–90, 1991: Standard Guide for Designing Systems for Oxygen



Additional Oxygen Considerations

- Because everything has increased flammability in O₂ environments, system cleanliness is extremely important
- Flow velocity (< 100 ft/s) and the rate at which valves open / close must be considered to avoid sudden deceleration (more important in high pressure gas systems) Control of cavitation is important in liquid systems



Cleanliness

- Multiple standards:
 - KSC-123 - Specifications for Surface Cleanliness of Fluid Systems
 - MSFC Spec 164: Cleanliness of Components for Use in Oxygen, Fuel, and Pneumatic Systems
 - ASTM G93–88: Standard Practice for Cleaning Methods for Materials and Equipment Used in Oxygen-Enriched Environments
 - CGA Pamphlet G–4.1: Cleaning Equipment for Oxygen Service
- Safety manual dictations a 300 A cleanliness level per KSC-123 and does not distinguish between high pressure gas and low pressure liquid systems
 - Particle counts (micron range)
 - Non-volatile residue (NVR)



Test Preparation and Check-Out

- Formal Reviews
- Check Sheets
- Cold Shock
- Leak Testing
- LN2 pre-run tests
- Purging



Formal Project Reviews

- Engineering Peer Review (EPR) – Review researchers formulation of science, test objectives & approach to experiment
- System Requirements Review (SRR) – Review programmatic and test requirements & the approach to verifying compliance that the experimental objectives & test requirements will be satisfied
- Preliminary Design Review (PDR) – Review test hardware & facility design to verify it will provide data called for by experimental requirements
- Critical Design Review (CDR) – Assesses the maturity of test hardware & facility design to verify it will provide data called for by experimental test requirements and establishes path forward to fabrication
- Test Readiness Review (TRR) – Review system to verify test article and facility is ready to run and institutional requirements have been met
- Test Data Review (TDR) – Post test initial technical review of data amongst peers (first look)

Reference: NPR 7123.1B, NASA Systems Engineering Processes and Requirements



Check Sheets

- Operational procedures are typically developed by test operations engineers. Purpose of check sheets is to:
 - Assure facility is operated safely
 - Provide consistent operating conditions for tests
- Typical check sheets include step-by-step procedures for:
 - Facility set up for fluids & gasses & mechanical systems
 - Pre-run set up
 - Test operations
 - Facility shut-down
 - Emergency procedures





Cold Shock

- The purpose of cold-shock testing is to verify compatibility of materials, equipment, and fasteners for cryogenic service
- Cold-shock testing at LN2 temperatures (-320° F) will produce at least 93% of the total thermal contraction obtained with liquid hydrogen (-423° F)
- Cryogenic test hardware and facilities experience extreme changes in temperature. This thermal cycling has a tendency to loosen up mechanical connections (fittings, flanges, etc).
- Mechanical fasteners (bolts) are subject to relaxation at cryogenic temperatures Performing cold shocks prior to test allows personnel to re-torque bolts, re-tighten loose fittings and assure that there will be no leaks once testing begins.
- Requirements for cold shock are outlined in the NASA Glenn Safety Manual chapter 7





Fastener Relaxation

(test data from John Jurns)

Average % Decrease of Bolt Torque

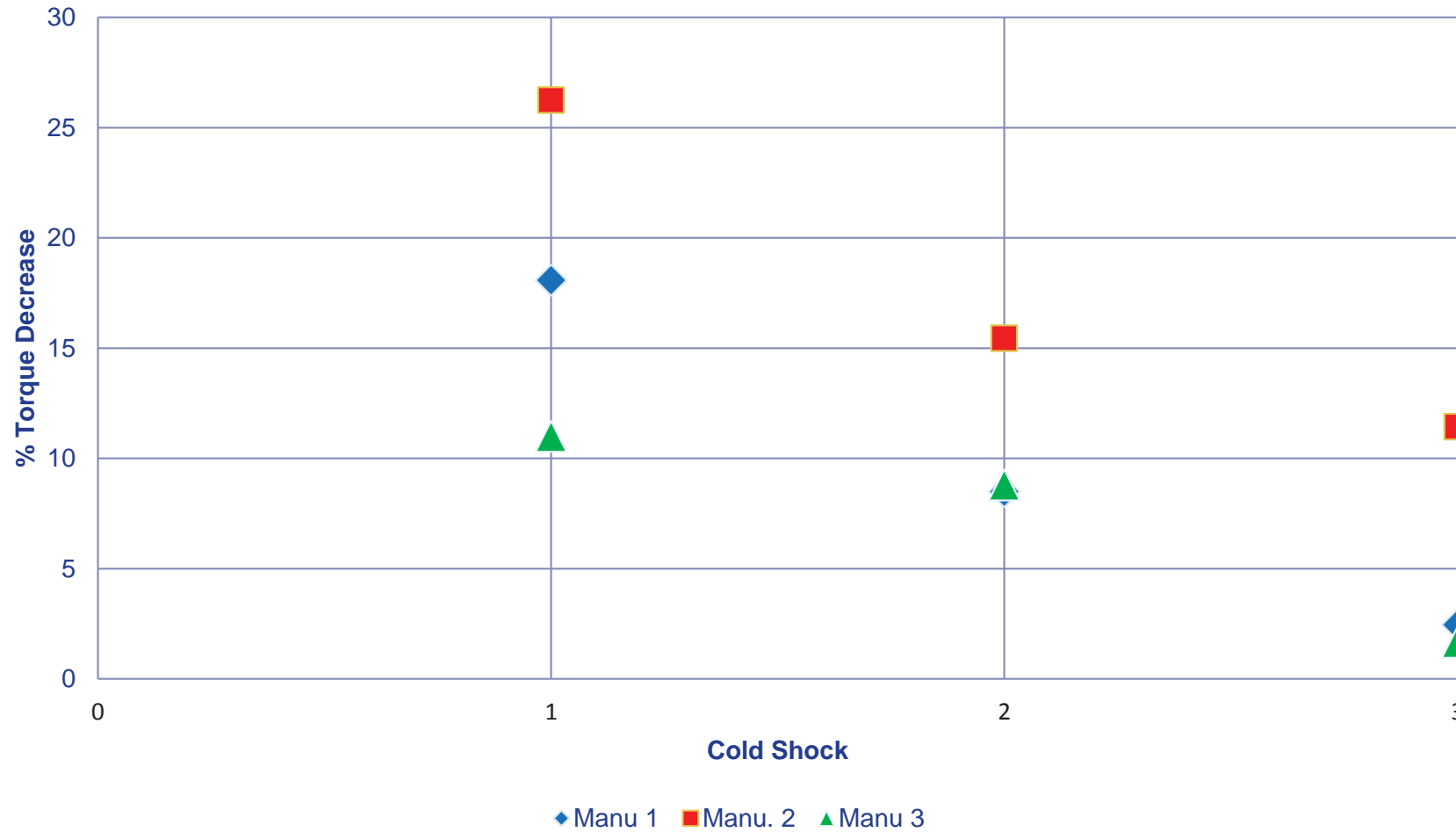



Leak Testing

- For cryogenic equipment, leak testing is performed after the LN2 cold shock test (a GSM Ch7 requirement for pressurized cryogenic systems)
- ASME B&PV Code & B31.3 requires an initial pneumatic leak test be performed at 1.1 times Design Pressure.
 - This test is sometimes referred to as a “Proof Pressure” or “Pressure Strength” TEST.
- Leak testing is required to verify the structural/mechanical integrity of the system (no distortion or signs of yielding) and to ensure there are no unacceptable leaks prior to operation
- Leak test methods are:
 - Hydrostatic @ 1.5 X Design Pressure
 - Pneumatic @ 1.1 X Design Pressure
 - Initial Service @ Max. Expected Operating Pressure (MEOP)



Pneumatic Leak Testing

- For cryogenic systems, the pneumatic leak test is often the preferred method because water in the system may be difficult to remove if a hydrostatic test were used
- Pneumatic – Pressurizing the vessel or piping system with gas and checking for physical distortion, indications of yielding and leaks
 - Pneumatic leak testing is hazardous and care must be taken in developing the procedures and conducting the test
 - A Pressure Relief device is required
 - Set Pressure = 50 psi + Test P OR 110% of Test P (whichever is greater)
 - Test gas shall be non-flammable & nontoxic
 - Calibrated Pressure gauges must be used
 - A Low pressure leak check at 5 – 10 psig is required prior to test at 1.1 X DP
 - Test Sequence:
 - Pressurize to 50% of Test P and Hold
 - Raise pressure in 10% increments and Hold at Test P for 15 minutes
 - Lower pressure to DP and conduct up-close visual examinations and leak check



Liquid Nitrogen Pre-Run Checkout Testing

- Prior to formal testing with potentially hazardous cryogenic liquids (LH2, LO2, LNG), standard practice is to run through your test procedure with LN₂. These tests accomplish the following:
 - Verify that facility controls operate as designed
 - Exercise check sheets and update as required
 - Provide operating experience with a less hazardous cryogen
 - Uncover unanticipated facility characteristics
 - Check out instrumentation





Purging

- Purging is used to prevent fires by removing oxidizer from the system
- Purging also removes condensable components in air (water, N₂, O₂) which may freeze and prevent operation of valves and relief devices
- Want to choose purge gas based on boiling point
 - LCH₄ systems – N₂ works
 - LH₂ system
 - GHe (cost)
 - GN₂/GH₂
 - Purge w/N₂ to eliminate water and oxygen
 - Follow GN₂ purge with GH₂ purge
 - Requires different infrastructure
 - Need to determine cost effectiveness and potential ROI
 - LO₂ systems – N₂ works

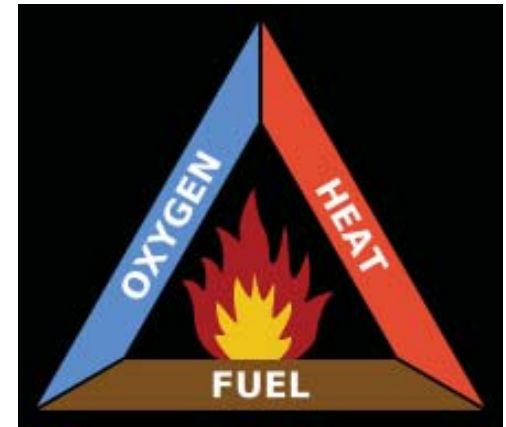

Pressure Purge

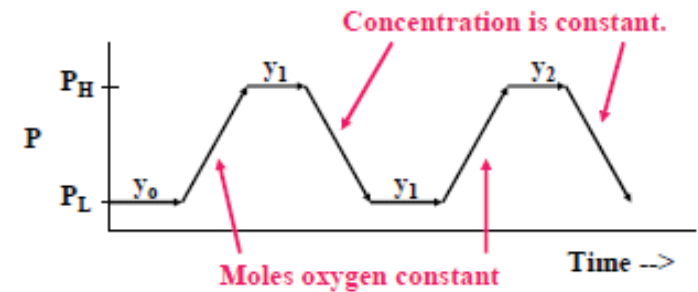

$$y_j = y_0 \left(\frac{P_L}{P_H} \right)^j$$

Faster than vacuum purge, but uses more nitrogen.



Formal Test Operations

- Formal testing begins when:
 - You have convinced the Authority Having Jurisdiction (AHJ) that you can operate safely (approvals)
 - You have convinced yourself that you are ready to test (checkout)
- Things to remember:
 - Maintain a log – don't assume you will remember what happened during a test weeks later when you are reviewing data
 - Watch what is happening – don't let your initial assumptions about the performance of a system prejudice your perception of what the data is indicating
 - Physics doesn't lie – if test results don't make sense (and you have ruled out instrument error), don't discount the test results. Chances are, they are telling you something important.
 - Unexpected results can sometimes provide the greatest insights into what is happening.
 - No matter how good your test plan, how well designed your facility, how thorough your checkout

Formal Test Operations

- Something will go wrong



- Budget time in your test for the unexpected
- It wouldn't be a bad idea to have a plan "B" for hardware or systems that pose greater risk for failure



Testing – Things to Watch For

- **Pressure spikes**

- Initial flow of cryogenic liquids to warm test hardware will result in rapid vaporization and pressure increase. Start slow.
- Maintain vapor space in test vessels. Liquids are incompressible. When a vessel is totally full with liquid, vapor generated due to heat leak has no place to go and can result in severe pressure spikes.

- **Unexplained pressure fluctuations**

- Chugging may occur if cryogenic liquids flow into warm dead legs of piping. The liquid can vaporize and cause a periodic pressure fluctuation
- Two phase flow – a mixture of vapor and liquid when you are expecting only liquid or vapor typically results in spiky pressures

- **Other pressure phenomena**

- Vapor in vessel ullage tends to warm faster than liquid, raising the pressure – mixing the liquid will expose colder liquid to the warm vapor and collapse ullage pressure
- Sub-atmospheric pressure – You may need to reduce pressure in a test vessel to below one atmosphere to achieve a test condition. Try not to leave the vessel in this state, as you may suck atmospheric gas into your process. Back fill the vessel with a non condensable gas (helium)



Testing – Things to Watch For

• Temperature

- In ground based tests, unless a cryogenic liquid is thoroughly mixed, the liquid temperature will typically stratify, with the warmer liquid rising to the top
- Pressurizing a vessel with helium will suppress boiling
- Liquid temperature at liquid/vapor interface will be in equilibrium with its partial pressure – warmer than the bulk liquid

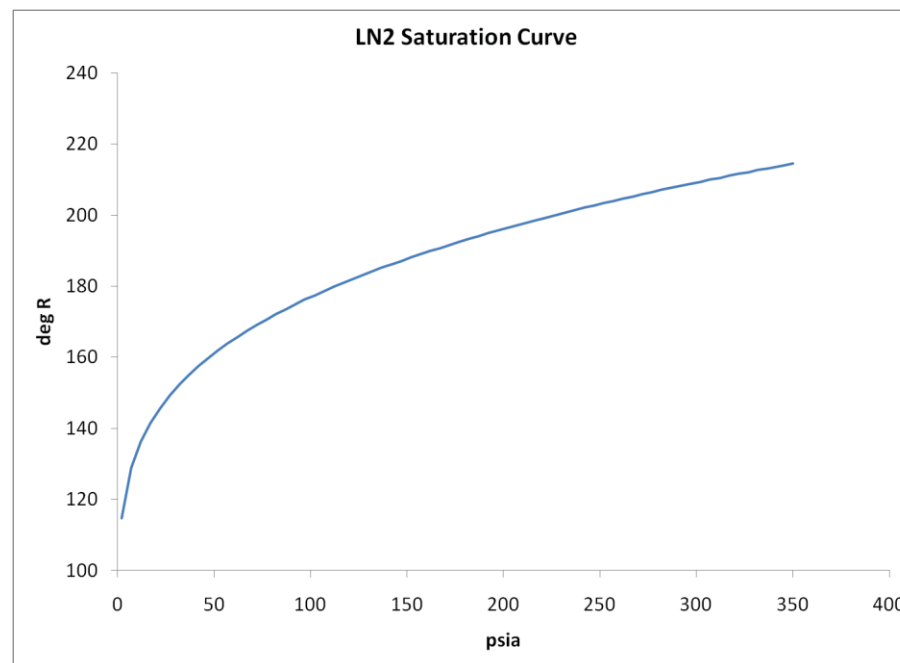



Data Analysis & Reduction

- Test log – as previously mentioned, maintain a detailed test log. Data needs to be interpreted in the context of what was happening during tests
- Compare test points to original planned test matrix – data seldom falls exactly on planned test conditions
- Compare test points to other published data sources
- Look for themes, trends & patterns in data
- Does the data satisfy the “Laws of Physics” and “Thermodynamics”
- Once you have determined what the data is actually saying, then go back and compare it to your initial assumptions to explain differences
- Does the data change any of your fundamental assumptions?
- Determine the quality of the data via an uncertainty analysis.

Data Analysis & Reduction

- Understand the fluids your dealing with. For **EXAMPLE** in the case of H₂
- Hydrogen molecules exist in two isomeric forms, Para and Ortho, depending on their nuclear spin configurations
- At room temperature (298 K) and higher the “equilibrium” concentration of hydrogen is 25% Para-hydrogen (p-H₂) and 75% Ortho-hydrogen (o-H₂) This gas “mixture” is referred to as “Normal Hydrogen” (n-H₂)
- But at hydrogen’s normal boiling point of 20.3 K (36.4°R), the equilibrium concentration is almost pure Para-hydrogen ($y = 99.79\%$ p-H₂). Thermodynamic (c_p) & Transport (k) properties significantly differ

H₂ - Diatomic Molecule



Specific Heat for Para and Normal Hydrogen at 1 atm

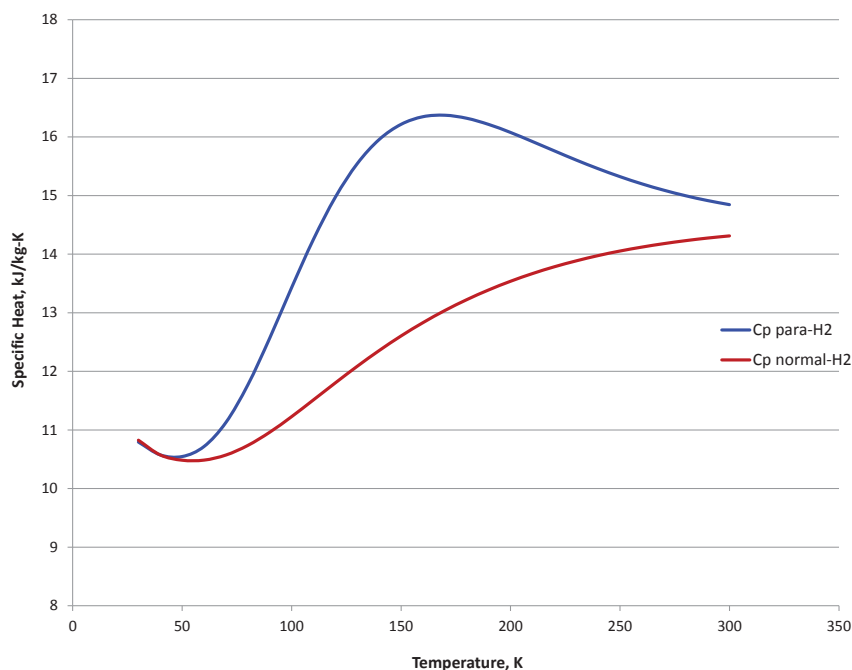

Thermal Conductivity for Para and Normal Hydrogen at 1 atm

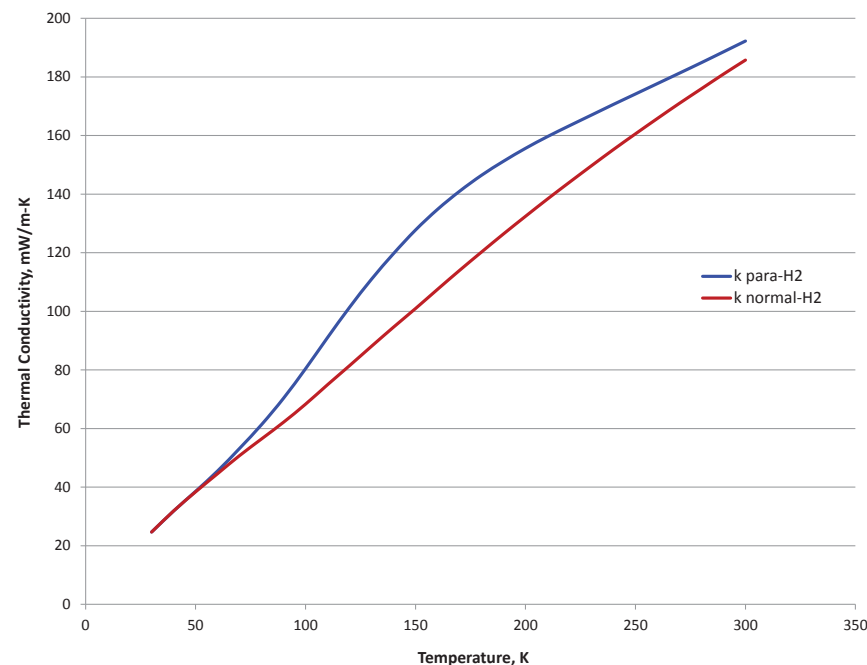



Data Analysis & Reduction

Line chill down test data – 0.5” OD x 80” SS tube at 3.5 lb/min LH2

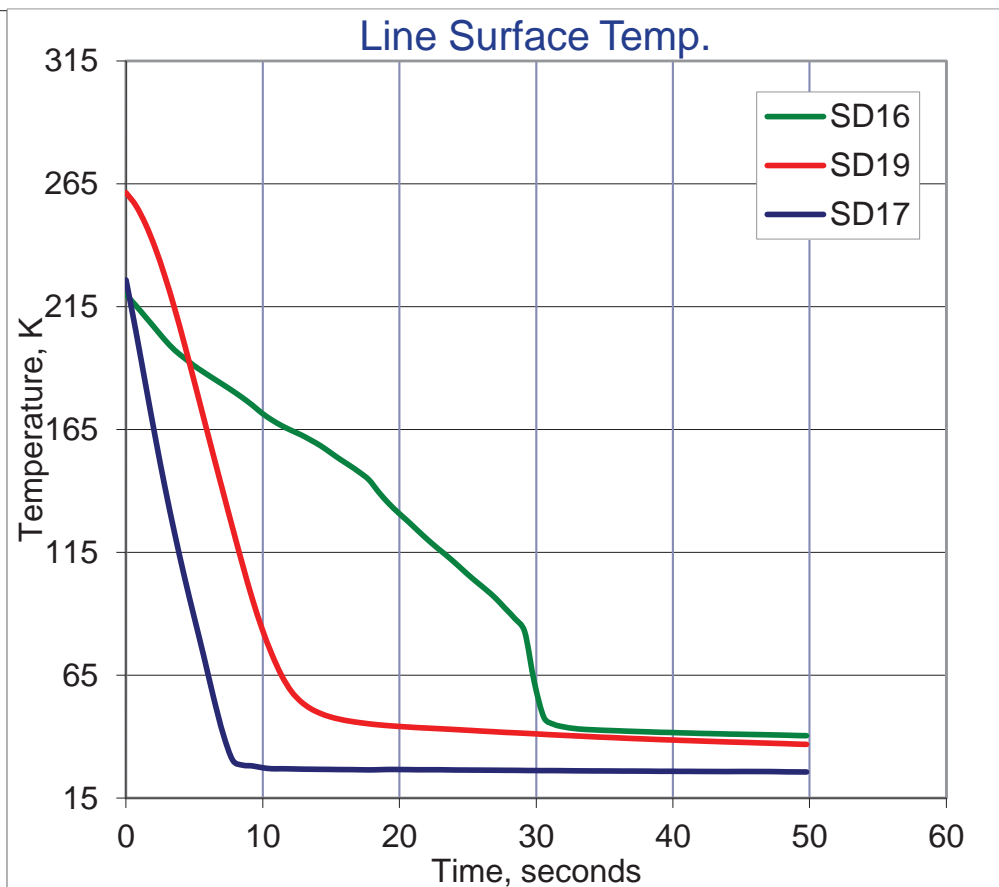
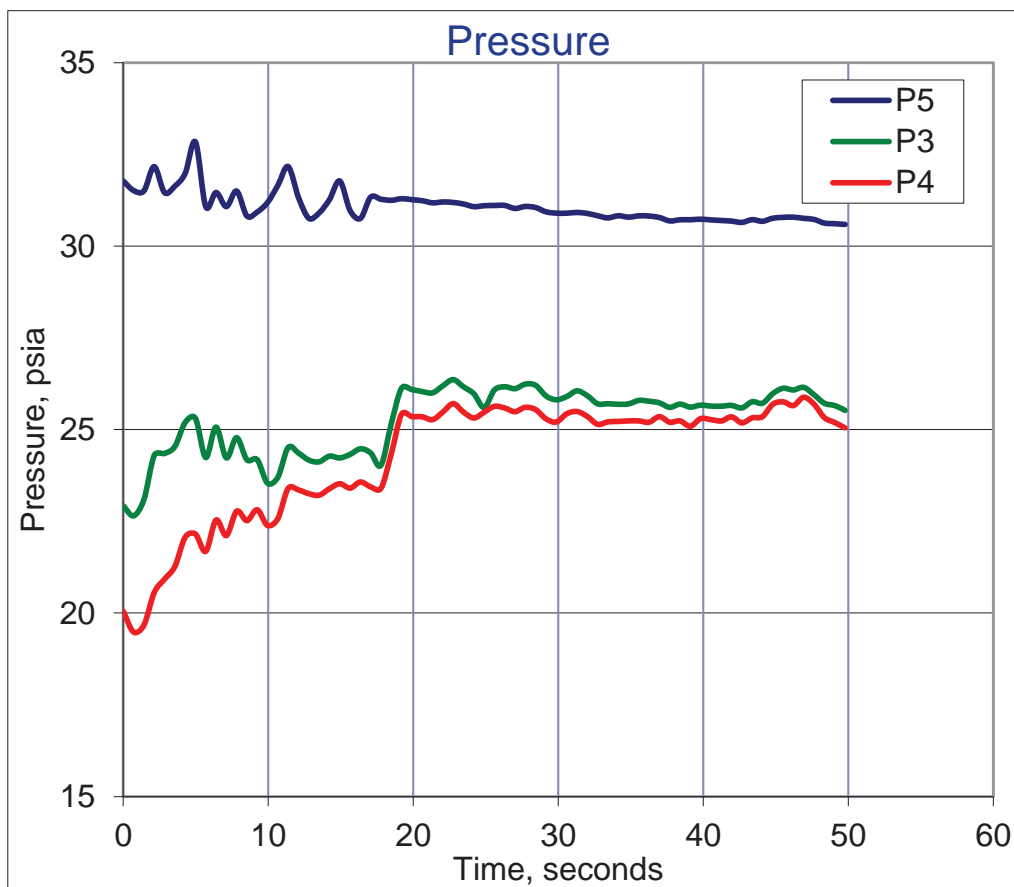

- ~ 30 psia Tank Driving Pressure
- 15 psia LH2 Inlet Sat'n Pressure



Data Analysis & Reduction

Temperature data vs. model prediction:

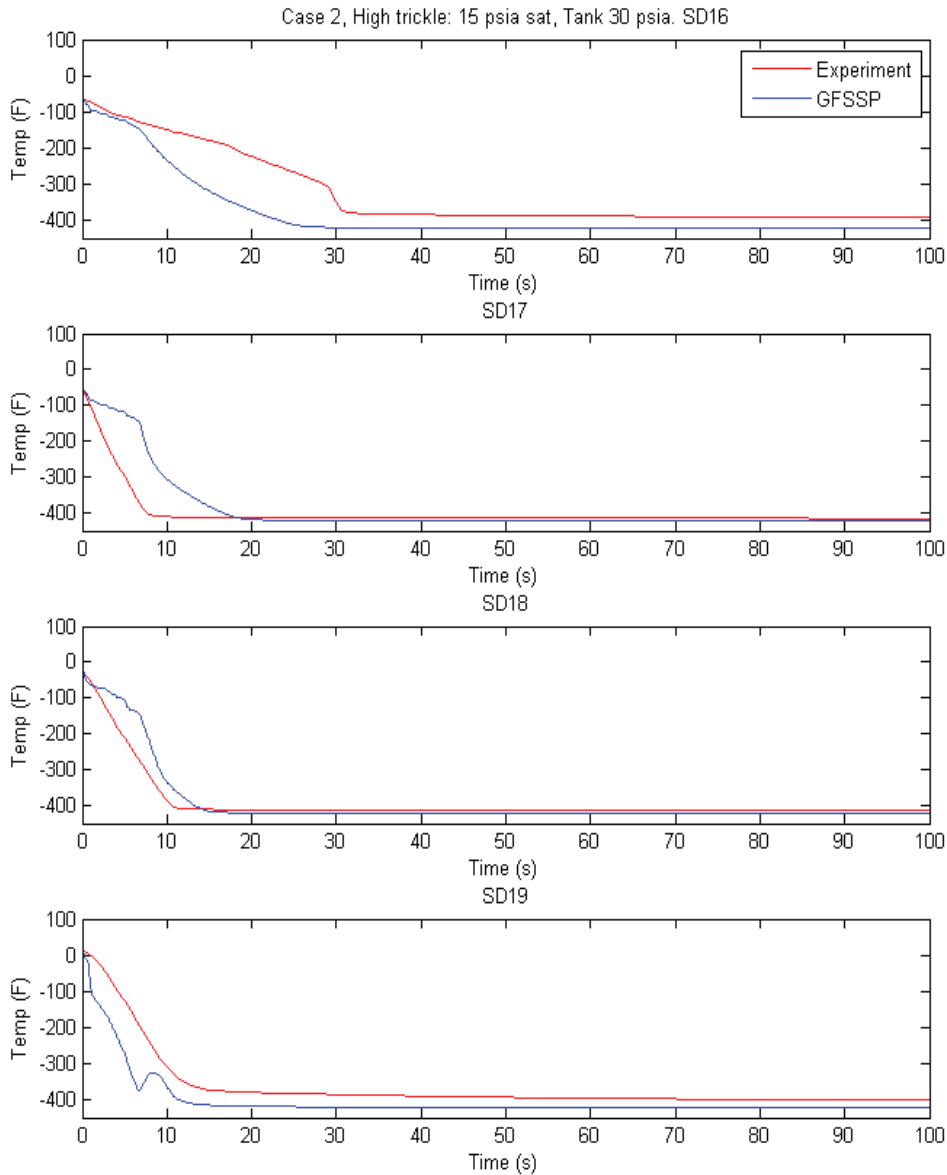

GFSSP Fluid Model Network

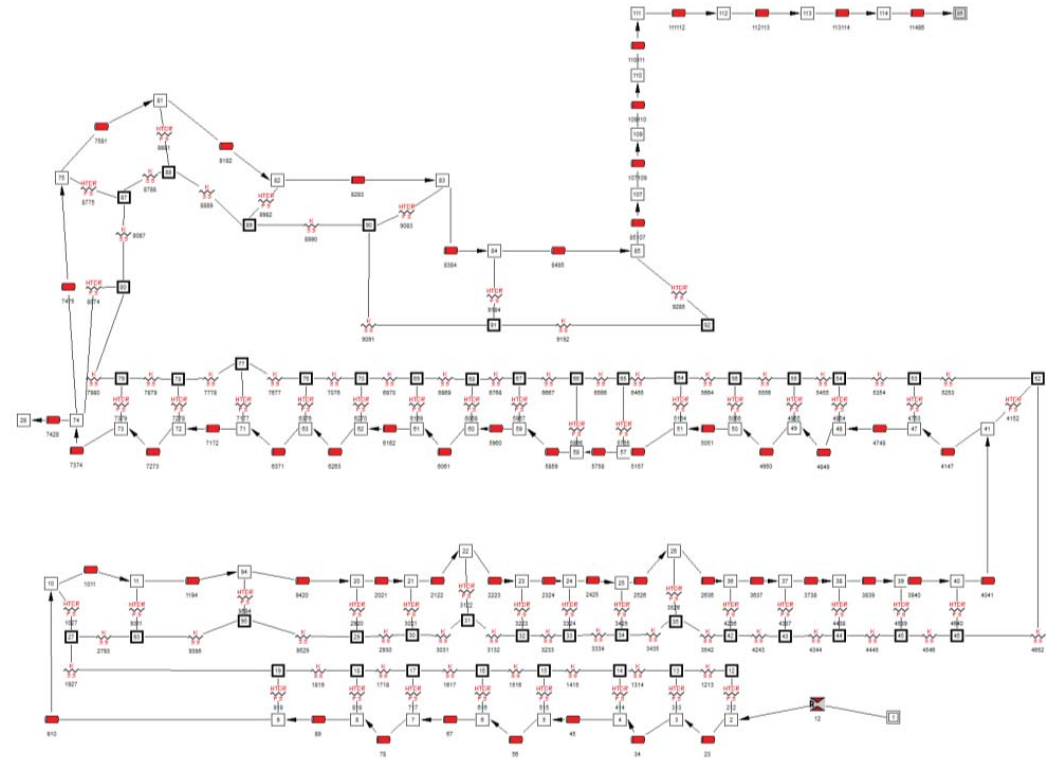
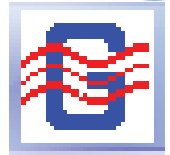

Details of the fluid system and cryogenic components are required to develop an accurate analysis

Model matches chill down curve/trend very well



Modeling and Analysis of Cryogenic Systems



Outline

Thermal Analysis of Heat into Tank (or Transfer Line)

System Level Sizing Tools

Multinode Analysis

Computational Fluid Dynamics (CFD) Analysis

Recommendations for Analysis Tool Usage



Thermal Analysis of Heat into Tank

Thermal Analysis of Heat into Tank

- Typically use Thermal Desktop to predict radiative heat load incident on tank for a specified orbit and in-space environment (or ground test environment)

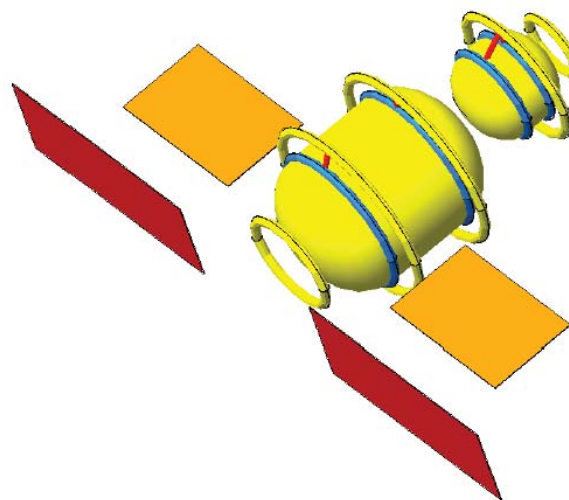
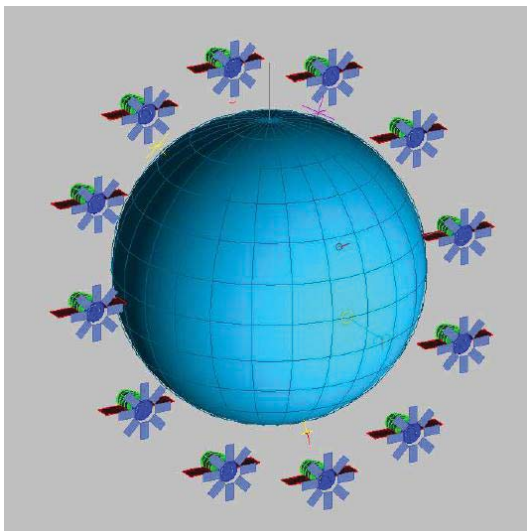

- Conductive heat loads into the tank may be calculated from Thermal Desktop or simple spreadsheet/hand calculations
- For validation against ground tests, often use the total heat load calculated from the measured vent mass flow rate (\dot{m}) of a boil-off test

$$\dot{Q}_{\text{boiloff}} = \dot{m} h_{fg} \left(\frac{\rho_{\text{satliq}}}{\rho_{\text{satliq}} - \rho_{\text{satvap}}} \right) + \dot{m} (h_{\text{vent}} - h_{\text{satvap}})$$



Thermal Analysis of Heat into Tank

- A large source of uncertainty in heat load calculations is the heat transfer through the Multi-Layer-Insulation (MLI)
- Several approaches currently exist for the calculation heat transfer through MLI
 - Acreage area by standard empirical equations
 - If not enough design details available use a “Scale Factor” to degrade performance to account for unknown details
 - Some historical data on cryogenic tanks is available
 - Seams, perforations, and pins need to be accounted for separately
 - Attachment methods for securing blanket to spacecraft or tanks also need to be accounted for separately
 - Integration of the MLI with the various fluid lines and struts/skirts need to be accounted for separately
- For thermal analysis prior to PDR (Preliminary Design Review), a 50% margin is typically added to all calculated heat loads



Thermal Analysis of Heat into Tank

An example of a detailed Thermal Desktop model was the LH2 Reduced Boil-Off (RBO) ground testing conducted at NASA Glenn using a *tube-on-shield* approach where a tubing loop is attached to an aluminum sheet embedded in the propellant tank Multi-Layer Insulation (MLI)

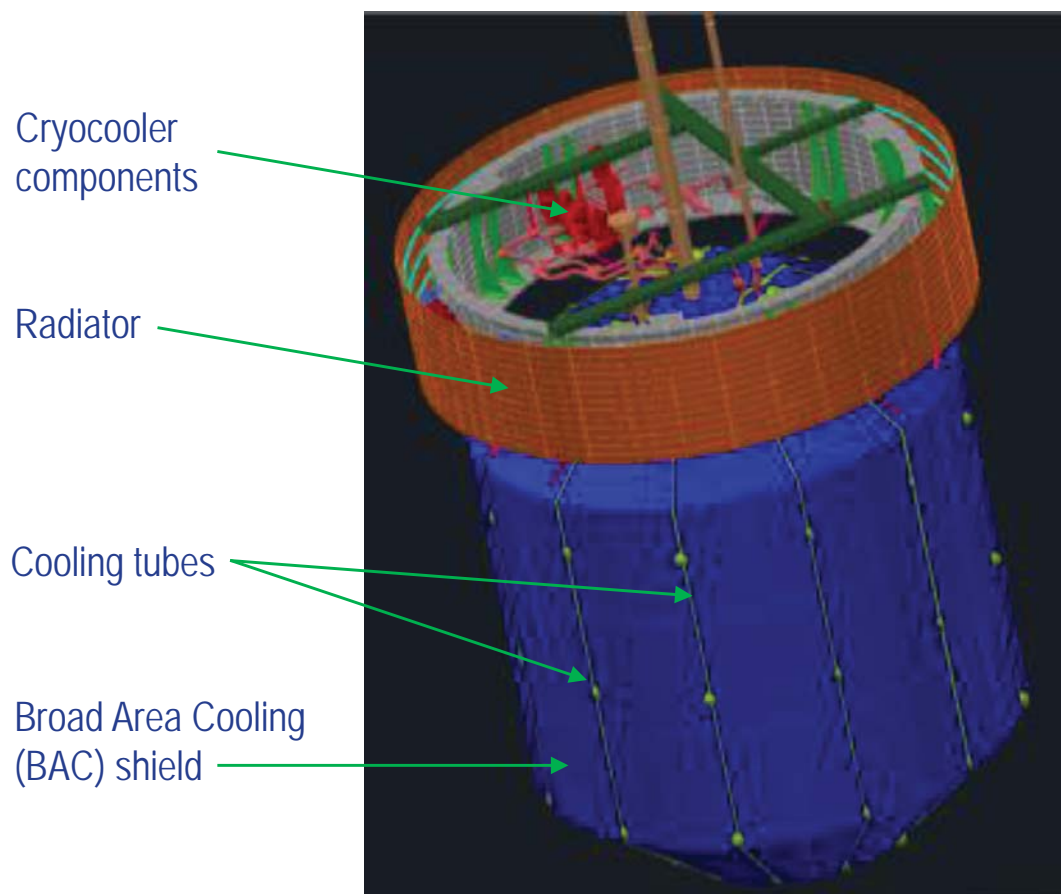

- Major components: Tank, hydrogen liquid/vapor (two nodes); SOFI, MLI, shield with BAC tubing and Ultem stand-offs, BAC supply/return manifolds, plumbing, struts, thermal straps, radiator, thermal shroud
- MLI blankets modeled using a modified Lockheed equation (MLE) Fortran subroutine. $DF = 3.5$ for both upper and lower blankets.
- Includes neon circulation loops on shield, with thermal straps to struts, fill line, and vent line.
- Neon circulation network coupled to cryocooler sub-model with performance relations correlated to Create test data.



System Level Sizing Tools



CryoSIM

- Cryogen Storage Integrated Model (CryoSIM) CFM system sizing tool provides mass, power and heat load estimates
 - System level conceptual/preliminary design studies and trade studies
 - Passive and Active cryogenic propellant in-space storage systems
 - Assumes on-orbit steady-state conditions
 - Units are kg, m, sec, K, W, kJ unless noted otherwise
- In-house Fortran code, version 2.0
- User's Manual is available



Heat Load Calculations

- Tank support structure and tank penetrations
 - Input from thermal analysis
 - Conductance with boundary temperatures
 - Empirical estimate is available
 - Heat may be intercepted via active cooling
 - Working temperature and location inputs
 - Location trade via external tool (only for LH2 with 90 K cooler)
- Tank Insulation
 - Modified Lockheed Equation
 - Constant or variable density MLI (up to 3 sections)
 - Iterative solver
 - Heat may be intercepted via active cooling
 - Working temperature and location inputs
 - Location trade via external tool (only for LH2 with 90 K cooler)



MLI Performance Equation

• Modified Lockheed Equation

- NASA/TM-2004-213175, Hastings, L. J., Hedayat, A., and Brown, T. M., *Analytical Modeling and Test Correlation of Variable Density Multilayer Insulation for Cryogenic Storage*, NASA/MSFC, May 2004.
- Used in CryoSIM sizing tool and in SINDA/FLUINT user subroutines
- Solid conduction, radiation, free-molecular conduction terms
- Performance degradation due to penetrations/seams/edges accounted for with a multiplication factor (usually called a “Degradation Factor or Scale Factor”)
- Modern flight materials (0.25 mil Double Aluminized Mylar, B4A Dacron, etc.)
- Correlation to LH2 test data with tank-applied insulation (MSFC, 1996 - 1998)
- Heritage back to calorimeter testing at Lockheed Missiles and Space Co., Inc. (NASA CR-134477 aka “The Lockheed Report”, April 1974)

$$q = \left[\frac{C_s (0.017 + 7.0E - 6 * (800.0 - T_{avg}) + 2.28E - 2 * \ln(T_{avg})) (N^*)^{2.63} (T_h - T_c)}{N_s} + \frac{C_r \varepsilon (T_h^{4.67} - T_c^{4.67})}{N_s} + \frac{C_g P (T_h^{0.52} - T_c^{0.52})}{N_s} \right]$$

Constants

$$C_s = 2.4E-4$$

$$C_r = 4.944E-10$$

$$C_g = 14600.$$

Variables and units

q heat flux through MLI, W/m²

T_h hot boundary temperature, K

T_c cold boundary temperature, K

T_{avg} average of hot and cold boundary temperatures, K

N* MLI layer density, layers/cm

N_s number of MLI layers

ε MLI layer emissivity, ε = 0.031

P interstitial gas pressure, torr



Heat Load Calculations (continued)

- Thermodynamic Vent System

- Spray Bar

- Subroutine calculates power and heat load from tank height, liquid density and pump flow rate
 - Average power and heat load based on duty cycle of 5%
 - Ref.: Hedayat, A., *Preliminary TVS Weight Scaling Analysis*, Presentation to MSFC Propulsion Department CEV Monthly, January 2008.

- Axial Jet

- Subroutine scales power and heat load from Shuttle Centaur LH2 Tank TVS System based on tank volume, liquid density and pump flow rate
 - Average power and heat load based on duty cycle of 5%
 - Ref.: Halsey, D., *A Zero-Gravity Thermodynamic Vent System for a Liquid Hydrogen Tank*, Sunstrand Corporation.



Mass Calculations

- Active elements

- Broad area cooling

- $m_{shield} = a_{shield} A_{tank}$, $a_{shield} = 0.6 \text{ kg/m}^2$ (broad area cooling shield with tubing)
 - $m_{tubing} = a_{tubing} A_{tank}$, $a_{tubing} = 0.03 \text{ kg/m}^2$ (broad area cooling tubing on tank wall)
 - Ref.: Feller, J. R., *Mass and Power Correlations*, August 2011 (revised July 2012).

- Dedicated power system

- $m_{sp} = a_{sp} P_{in}$, $a_{sp} = 0.036 \text{ kg/W}$
 - Ref.: Kerslake, T. W., and Gefert, L. P., *Solar Power System Analyses for Electric Propulsion Missions*, NASA/TM-1999-209289, July 1999.

- Dedicated radiator

- $m_{rad} = \frac{Q_{rej} * \rho_{rad}}{\sigma * 0.9 * 0.85 * (T_{rad})^4}$



Mass Calculations (continued)

- Propellant loss

- $m_{boiloff} = \frac{(q_{Total} \cdot t) + E_{input}}{\Delta H_{vap}}$

- Rough estimate of vented propellant only

- Liquid acquisition device

- $m_{LAD} = A_{tank} * 2.9$ (screen galleries)

- $m_{LAD} = A_{tank} * 0.57$ (vanes)

- Ref.: Golliher, E., *Liquid Acquisition Device: Preliminary Estimate of Liquid Acquisition Device Mass*, Version 1.0.0, August 30, 2009.

- Mass gauge

- $m_{MG} = 20.0 + 1.0 * LD$, LD = tank longest dimension

- Ref.: Moran, M., *Mass Gauging System: Preliminary Estimate of Propellant Mass Gauging System Power & Mass*, Version 1.0.0, July 7, 2009.

- Tank

- Tank mass used in empirical conductive heat load estimate
 - User input
 - Empirical estimate based on tank dimensions is available

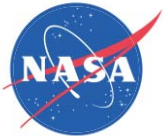

Mass Calculations (continued)

- Thermodynamic Vent System
 - Spray Bar
 - Subroutine scales mass from MHTB LH2 Tank TVS System based on tank height
 - Ref.: Hedayat, A., *Preliminary TVS Weight Scaling Analysis*, Presentation to MSFC Propulsion Department CEV Monthly, January 2008.
 - Axial Jet
 - Subroutine scales mass from Shuttle Centaur LH2 Tank TVS System based on tank heat loads, liquid properties and pump flowrate
 - Ref.: Halsey, D., *A Zero-Gravity Thermodynamic Vent System for a Liquid Hydrogen Tank*, Sunstrand Corporation.

- Tank Insulation
 - Subroutine estimates the mass of a 3 section Variable Density MLI system with SOFI substrate and Outer Layer (Purge Bag, Beta Cloth, etc.)
 - Constant or variable density MLI (up to 3 sections)
 - Modern flight materials (0.25 mil Double Aluminized Mylar, B4A Dacron, etc.)
 - Ref.: Hedayat, A., and Johnson, W., *3LayersSP4VS-MLIProgram_WLJ.xls*, VDMLI Performance Spreadsheet, 2006.



Power Calculations

- Mass gauge

- $P_{MG} = 100.0 + 1.0 * LD$, LD = tank longest dimension
- Ref.: Moran, M., *Mass Gauging System: Preliminary Estimate of Propellant Mass Gauging System Power & Mass*, Version 1.0.0, July 7, 2009.



Mass and Power Calculations

- Cryocooler/circulator

- 90 K

- $m_{cc90} = a_{cc90} P_{cc90}$, $a_{cc90} = 0.044 \text{ kg/W}$

- $P_{cc90} = b_{cc90} Q_{L90}$, $b_{cc90} = (2.0 \text{ W/W}) \left[1 + \left(\frac{T_{rej}}{T_{L90} - \Delta T} \right)^2 \right]$

where Q_{L90} is the heat removed from the load at the load temperature T_{L90} , and ΔT is the temperature drop between the load and the cryocooler cold head.

- 20 K

- $m_{cc20} = a_{cc20} P_{cc20}$, $a_{cc20} = 0.044 \text{ kg/W}$

- $P_{cc20} = b_{cc20} Q_{L20}$, $b_{cc20} = (70 \text{ W/W}) \frac{T_{rej} - 20 \text{ K}}{280 \text{ K}}$

where Q_{L20} is the heat removed from the load at the load temperature.

- Ref: Feller, J. R., *Mass and Power Correlations*, August 2011 (revised July 2012).



Passive CFM Mass Trade Example

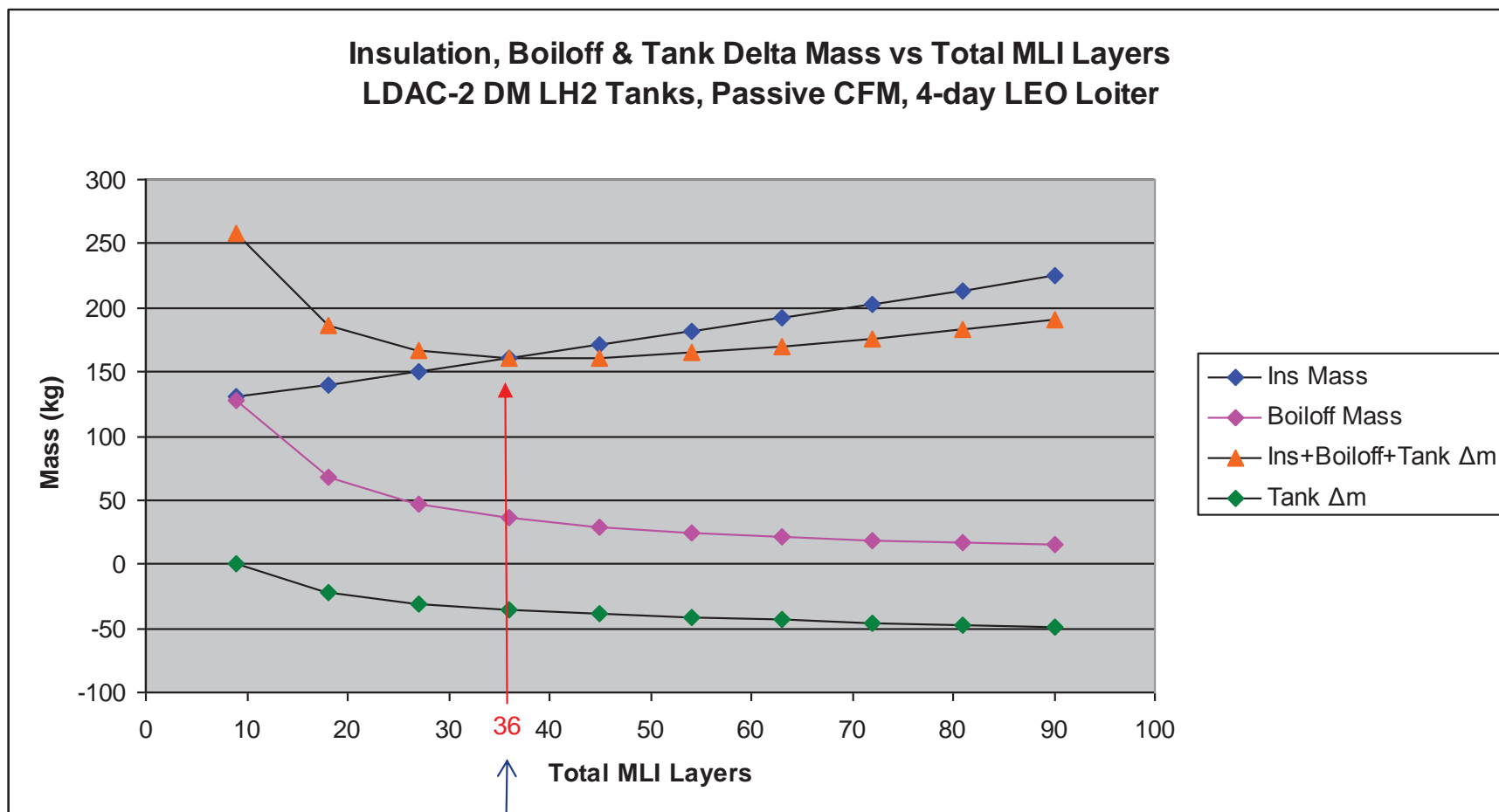

Optimum number of MLI layers for this specific example (LH2, tank size, 4-day LEO loiter)



Active/Passive CFM Trade Example

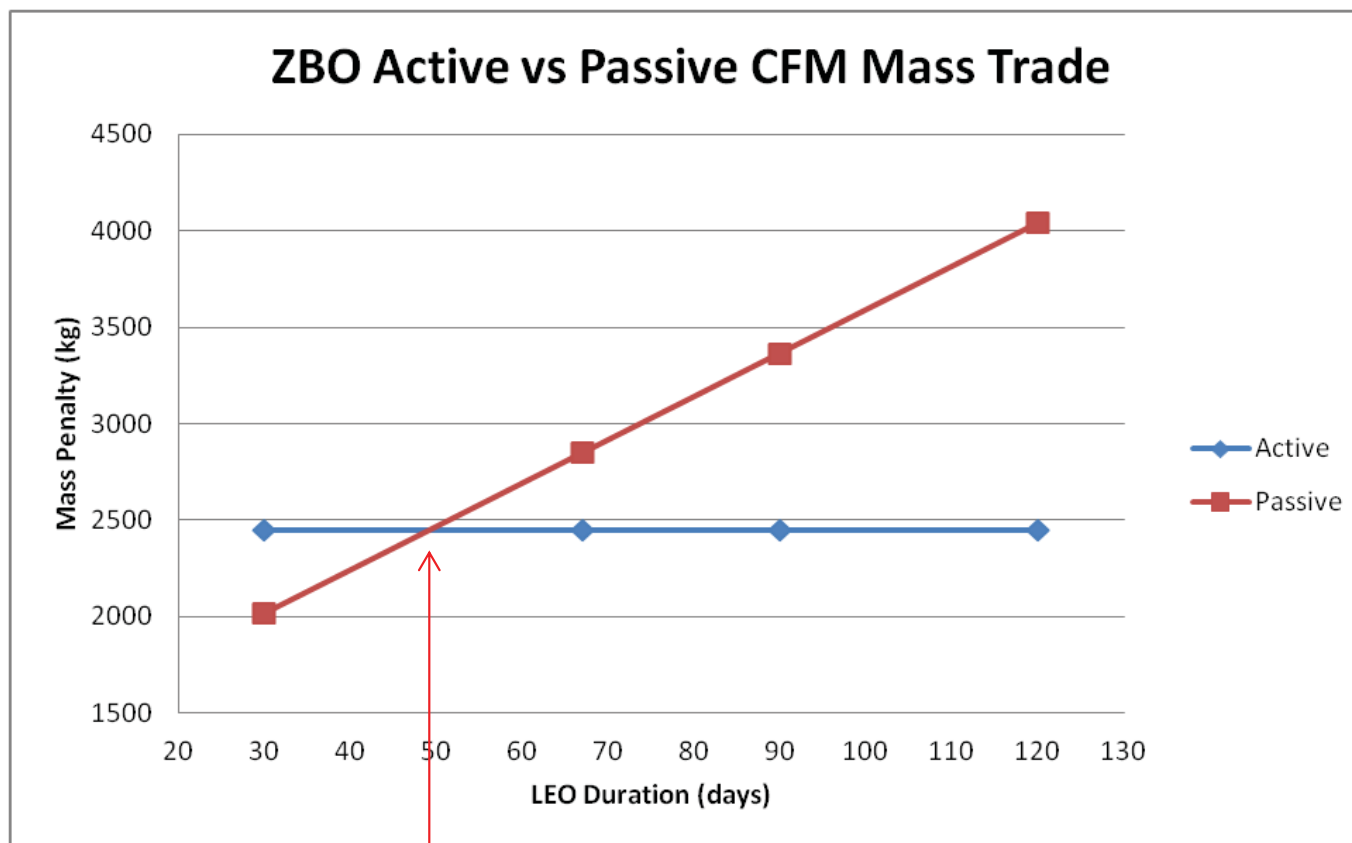

Number of days LEO storage beyond which using an active thermal control system (cryocoolers/Broad Area Cooling) provides a benefit in terms of reduced CFM system mass (for this specific example).

Temperature and Heating Rate Solver Verification

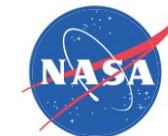

Verification of CryoSIM Iterative Solver	CryoSIM		SINDA/FLUINT			
LEDS LH2 Tank Dimensions						
Diameter (m)	8.3000		8.3000			
Cylinder length (m)	5.4000		5.4000			
Dome Height (m)	3.1121		3.1121			
Surface Area (m ²)	322.1995		322.1995			
Propellant Mass (kg)	35245.02		35245.02			
Propellant Temp. (K)	22.8		22.8			
Shroud Temp. (K)	206.5		206.5			
SOFI Thickness (m)	0.0127		0.0127			
VDMLI						
VDMLI Total # layers	72		72			
VDMLI Segment 1 (Inner) # layers (8 layers/ cm)	16		16			
VDMLI Segment 2 (Middle) # layers (12 layers/ cm)	24		24			
VDMLI Segment 3 (Outer) # layers (16 layers/ cm)	32		32			
Heat Rates & Surface Temperatures (W/m², K)						
Tank/SOFI Interface (q ₀ , T _c)	Heating Rate	Temp.	Heating Rate	Temp.	Heat Rate	Temp
SOFI/VDMLI Segment 1 Interface (q ₁ , T ₁)	0.075584	22.800000	0.075583	22.800000	% Diff.	% Diff.
VDMLI Segment 1/2 Interface (q ₂ , T ₂)	0.075581	118.552077	0.075583	118.552100	0.001969	Bound. Cond.
VDMLI Segment 2/3 Interface (q ₃ , T ₃)	0.075583	171.660958	0.075583	171.661000	0.001328	-0.000002
Radiation Gap (q ₄ , T ₄)	0.075584	204.620030	0.075583	204.620000	-0.002220	-0.000019
Shroud (-, T _h)	-	206.500000	-	206.500000	0.000225	-0.000024
Heat Loads (W)	Heat Load	(CryoSIM)	Heat Load	(S/F)	% Diff.	(btw codes)
MLI	29.223822		29.223246		0.001983	0.000015
					-	Bound. Cond.



Insulation Mass Calculations Validation

Validation of CryoSIM Insulation Mass Calculations

Based on published mass (kg) of MHTB MLI system (per NASA/TM-2001-211089)

	MHTB Published	3LayersSP4VS- MLIProgram.xls Spreadsheet	% Error	CryoSIM Routine	% Error
Flight MLI and MHTB SOFI	69.76	67.26	-3.58	67.32	-3.50
MHTB MLI & SOFI	78.00	74.61	-4.35	74.71	-4.22
Flight MLI & SOFI	42.54	39.23	-7.78	39.28	-7.66

Dome-to-cylinder overlap is not accounted for.



Stand-alone

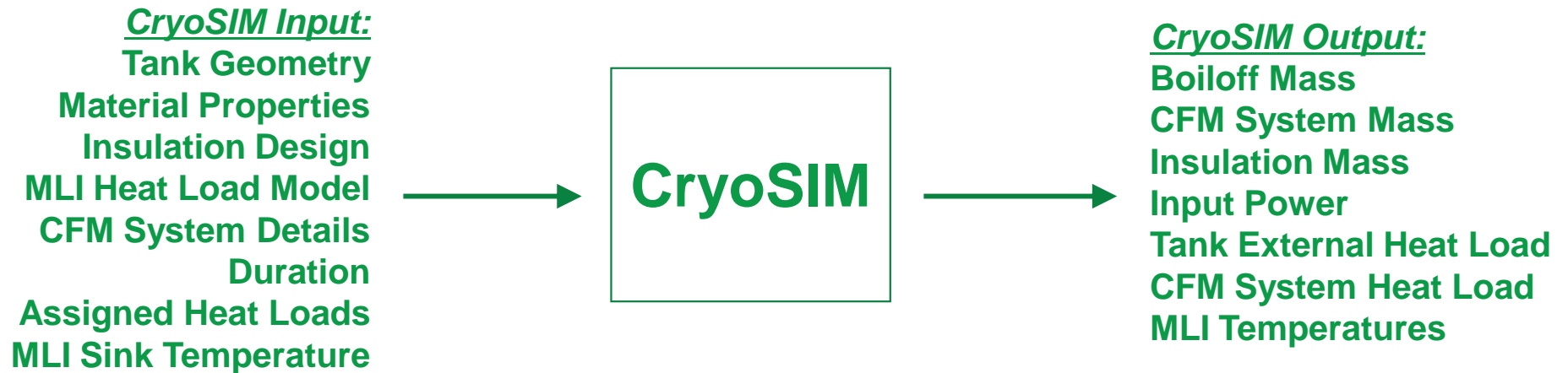



CFM Model Only

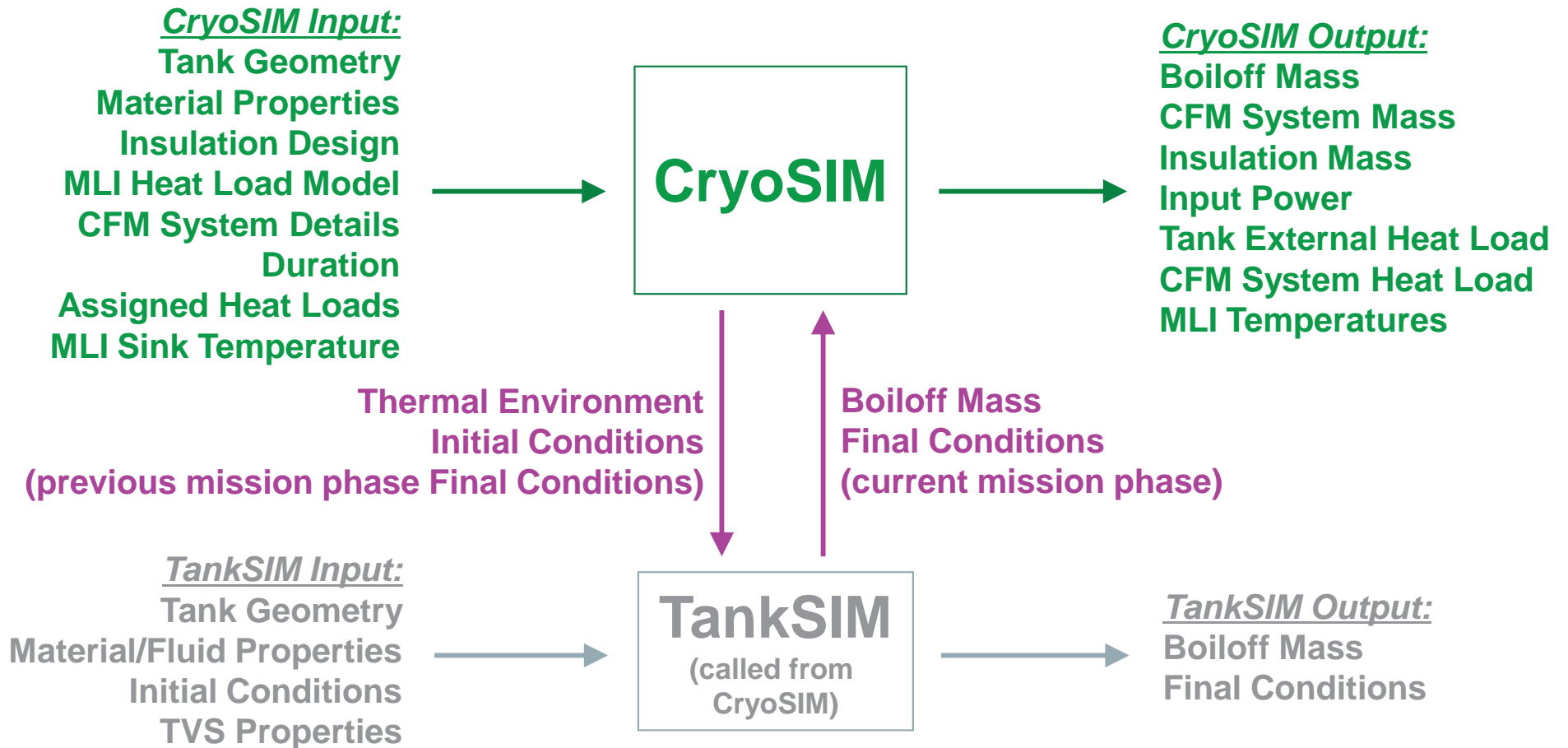



Integrated Vehicle/CFM Model

Thermal Desktop Input:

- Vehicle Geometry
- Environment Inputs
- Assigned Heat Loads
- Tank Geometry
- Material Properties
- Insulation Design
- MLI Heat Load Model
- Problem Logic

CryoSIM Input:

- Tank Geometry
- Material Properties
- Insulation Design
- MLI Heat Load Model
- CFM System Details
- Duration
- Assigned Heat Loads

TankSIM Input:

- Tank Geometry
- Material/Fluid Properties
- Initial Conditions
- TVS Properties

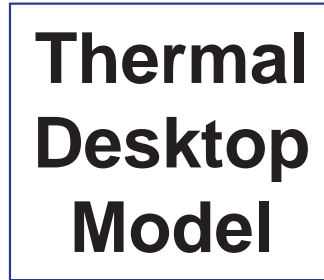

SINDA/FLUINT Output:

- Vehicle Temperatures
- Vehicle Heat Loads
- Heating Rate Breakdown

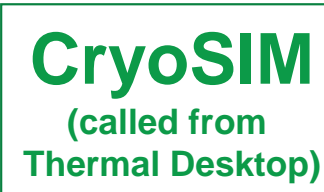

CryoSIM Output:

- Boiloff Mass
- CFM System Mass
- Insulation Mass
- Input Power
- Tank External Heat Load
- CFM System Heat Load
- MLI Temperatures

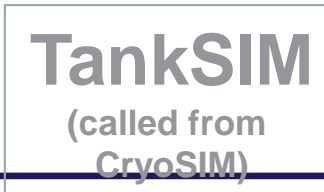

TankSIM Output:

- Boiloff Mass
- Final Conditions

Tank Total Heat Load
Tank Radiation Heat Load
MLI Sink Temperature

Thermal Environment
Initial Conditions
(previous mission phase Final Conditions)

Boiloff Mass
Final Conditions
(current mission phase)



Introduction to Multinode and CFD Analysis



Mission Phases to be modeled

- Mission phases that need to be modeled (settled and unsettled) include:
 - Self-Pressurization
 - Pressure Control: axial jet and spray bar TVS
(thermodynamic vent system)
 - Pressurization (helium and autogeneous)
 - Transfer Line Chillover (pulsed, continuous)
 - Tank Chillover (such as Charge-Hold-Vent)
 - Tank Filling (no-vent, vented)
 - Tank draining



Analysis Tool Capabilities include the following:

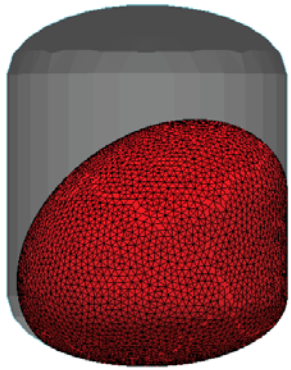

Equilibrium Interface Shape/Location

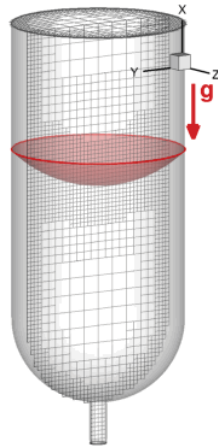

Draining

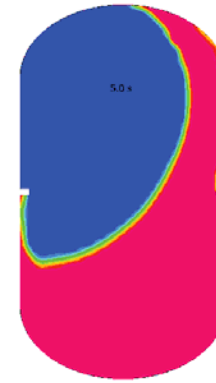

Slosh, Settling

Slosh with heat & mass transfer

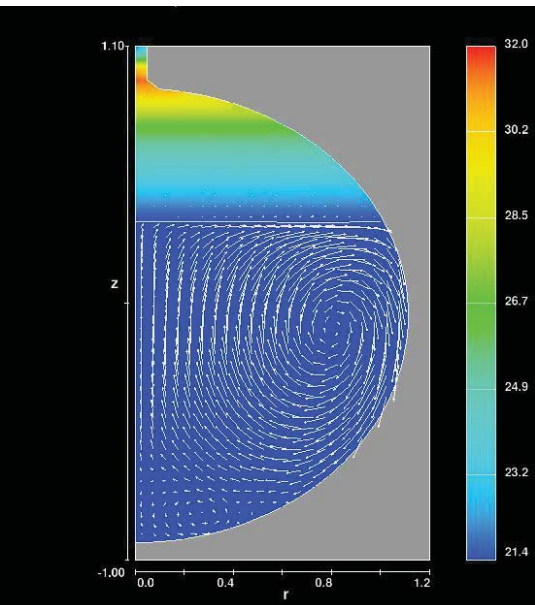
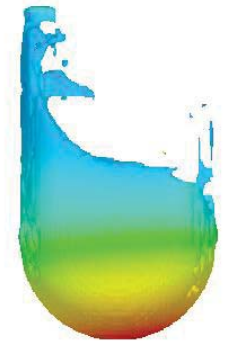

Self-Pressurization

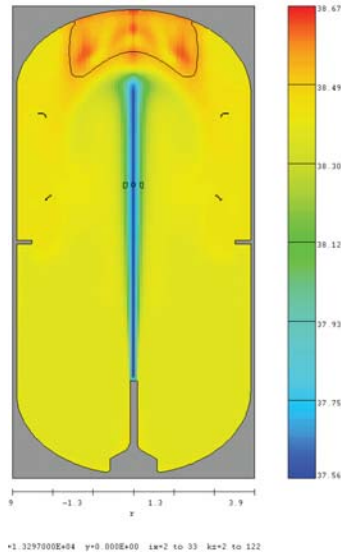

Pressure Control / TVS (axial jet or spray bar)

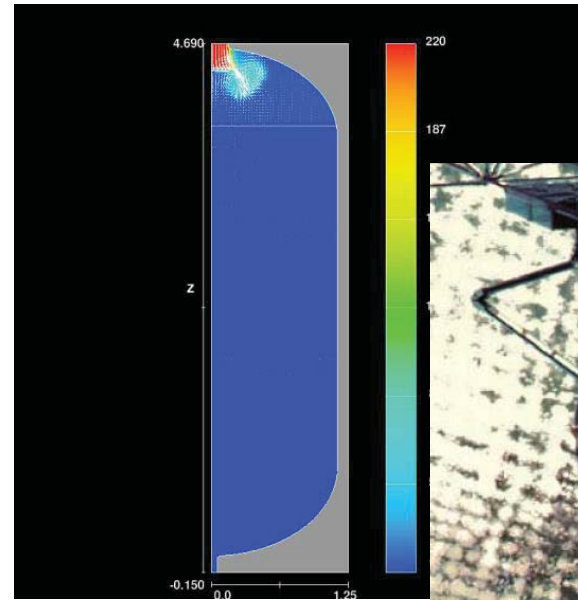

Pressurization

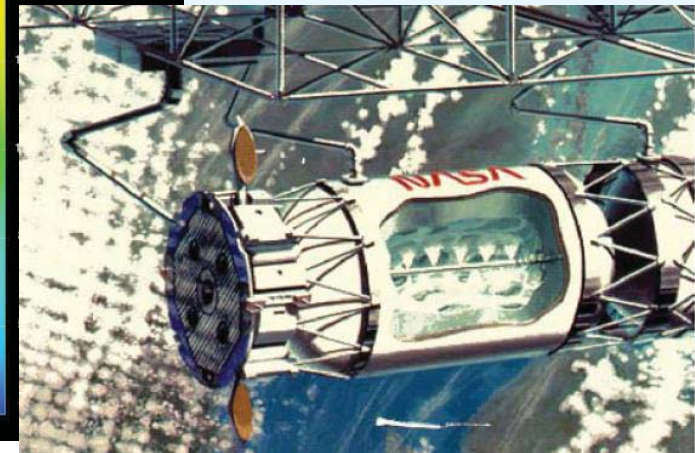

Tank-to-Tank Transfer

Multinode (Lumped Parameter) compared to CFD

Typical temperature contours are shown below for settled conditions

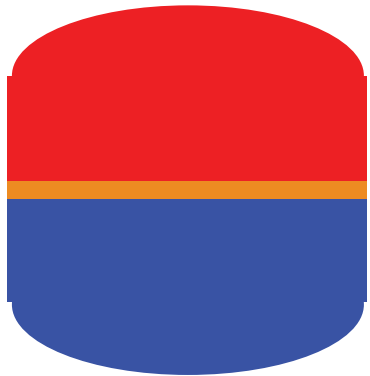

Multinode with one ullage, one liquid, one interface node
(TankSIM, CPPPO)

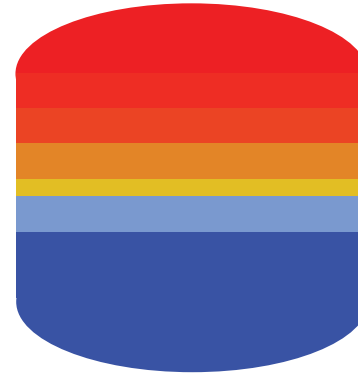

Multinode with multiple ullage & liquid nodes
(SINDA/FLUINT, GFSSP)

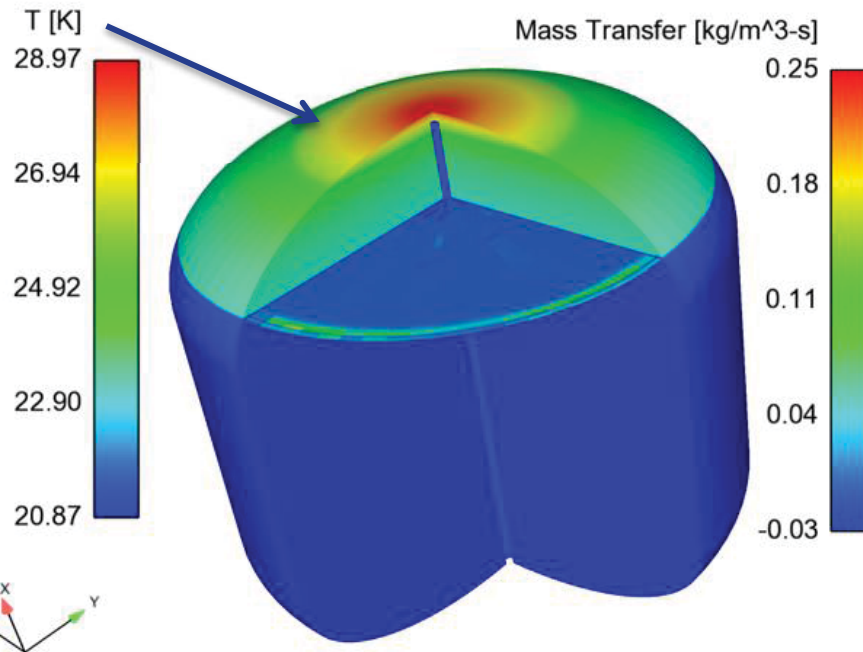

CFD using 2D-axisymmetric or 3D grids
(Flow-3D, Fluent)



Analysis Tools Development/Validation Approach

- Apply **existing thermal analysis tools** (e.g. Thermal Desktop) and **updated models for MLI and thermal strap** heat transfer to calculate **heat loads** into propellant tanks
- Develop **multinode and CFD** analysis models for the **fluid dynamics and thermodynamics** occurring within tanks and transfer lines under settled and unsettled conditions
- Validate models against cryogenic **ground test** (settled conditions) and **subscale flight data** (unsettled conditions)
- Develop code **coupling approaches** for integrated systems analysis
 - Predicting the dynamics of **ullage/liquid interface position and shape during unsettled conditions**, or during jet mixing or some pressurization methods where **deformation or breakup of interface** occurs, **requires** computational fluid dynamics (CFD)
 - Develop both multinode and CFD codes since **CFD simulations times** with a “typical” number of parallel licenses is **not practical for storage durations over a few hours**. *(1.7 hrs of LH2 storage using 32 processors took 1 week of CFD run time on NASA Pleiades supercomputer in 2013)*

K-Site LH2 Ground Experiments of self-pressurization, axial jet, tank chilldown, no-vent fill (1g)

K-site Facility at NASA Glenn, Plumbrook Station

Flightweight insulated aluminum ellipsoidal tank

- Internal volume: 175 ft³ (tank diameter = 2.2 m)
- Tests conducted in vacuum chamber.
- Tank is supported by 12 fiberglass composite struts.
- Test article is enclosed by a cryoshroud whose temperatures are maintained with electrical heaters.
- Tank insulated with 2 blankets of MLI.

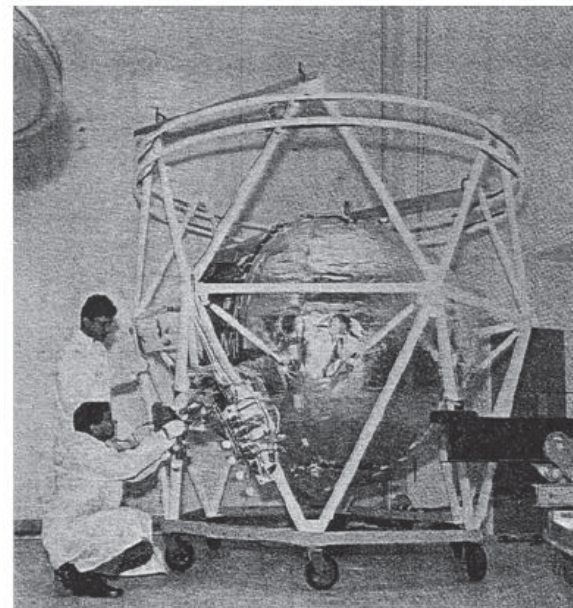

Test fluid is liquid hydrogen

Various Tests conducted during 1990's:

boil-off, self-pressurization, axial jet,
tank chilldown, tank no-vent fill

NASA TM-103804, 1991

NASA TM-104444, 1991

NASA TM-104458, 1991

NASA TM-105411, 1992

NASA TM-106629, 1994

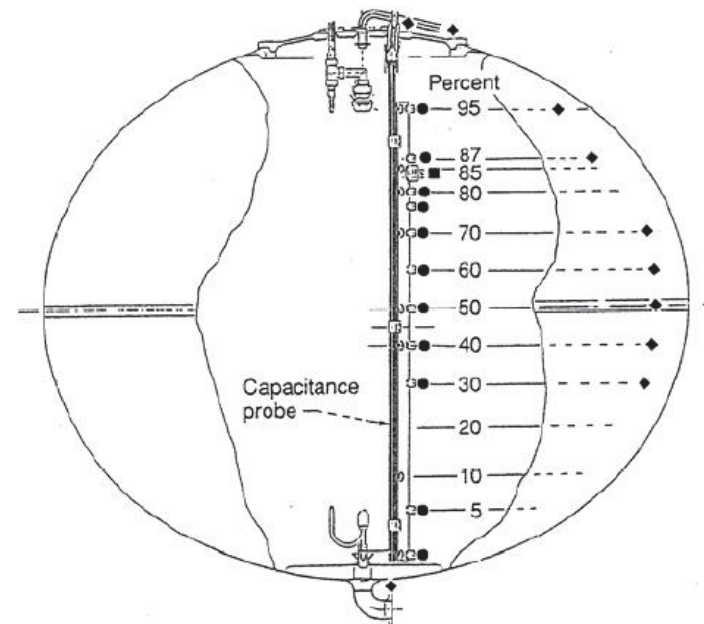

MHTB Self-Pressurization and Spray Bar TVS Ground-Based (1g) Experiments

NASA MSFC east test area thermal vacuum facility, Test Stand 300

Tank Internal volume 37.5 m³

Cylindrical midsection with:
height = 3.05 m

diameter = 3.05 m

2:1 elliptical end caps

Tank is enclosed in a vacuum shroud

4 spray bar tubes attached to
center tube heat exchanger

Test fluids: LH₂, LN₂, LCH₄
(with & without GHe in ullage)

NASA TM-212926, 2003

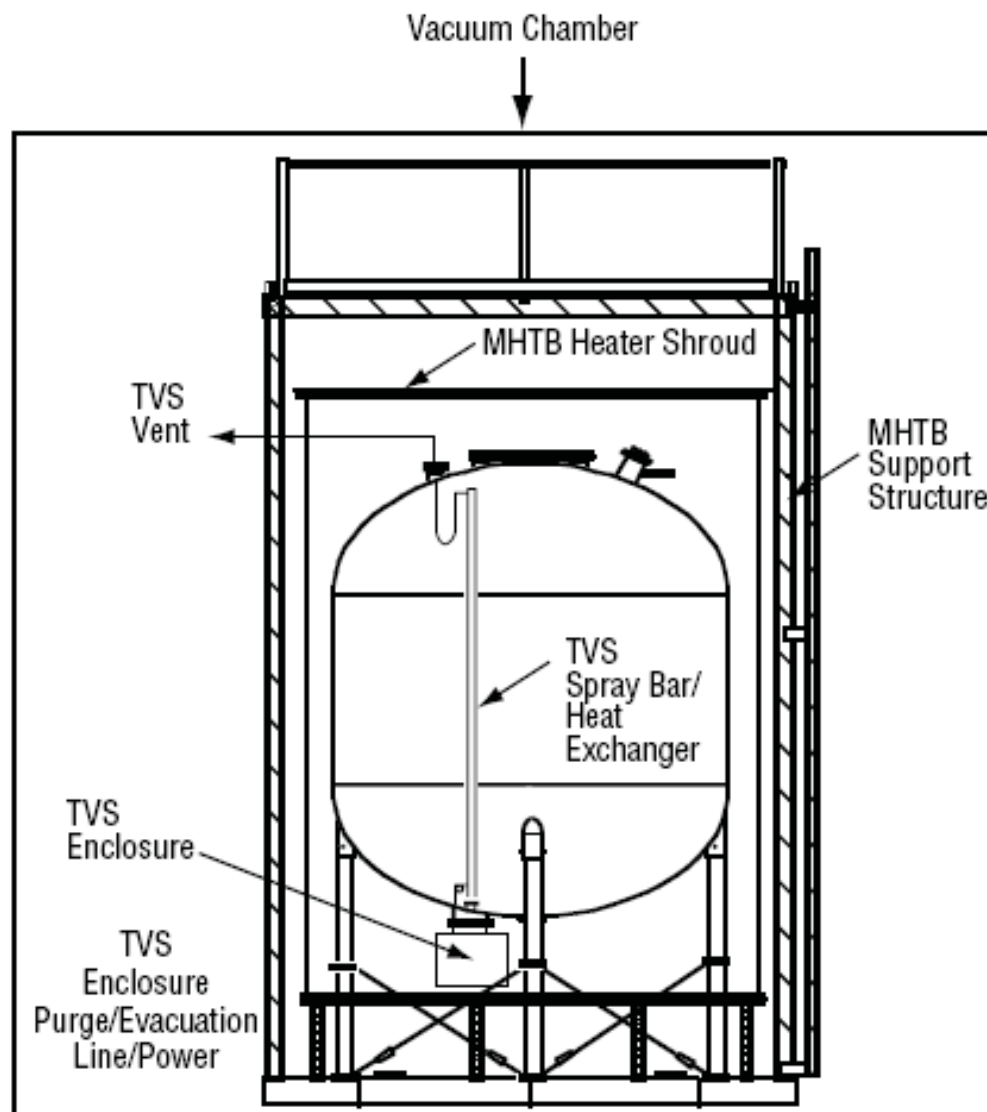



Shuttle Tank Pressure Control Experiments

- NASA-CR-191012 (1993), NASA-TP-3564 (1996), AIAA-1997-2816
- 25.4 cm (10 in) diameter by 35.6 cm (14 in) long cylindrical tank with hemispherical domes was constructed of transparent acrylic plastic
- Filled with Freon-113: 83% liquid fill for Shuttles flights 1 and 2. 39% liquid fill for 3rd Shuttle flight.
- Small amount (estimated 2% mass fraction) of noncondensable gas (helium, water vapor, and air) was present
- Straight-tube jet nozzle (1.016 cm ID). Jet Temperature NOT measured.
- “Top” (opposite jet nozzle) and Sidewall heaters submerged in tank away from wall
- Pressure, Fluid and Wall Temperature, & flow rates measured. Video recorded.

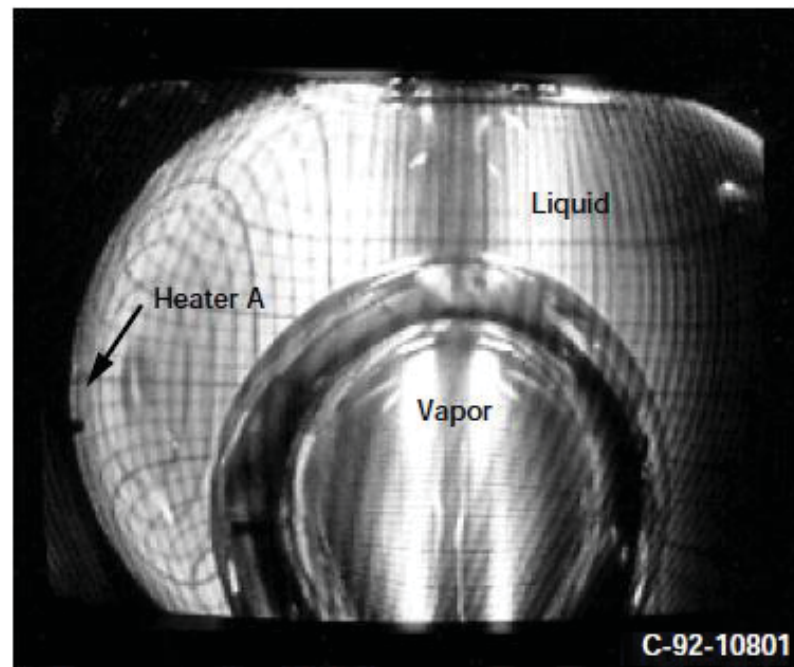
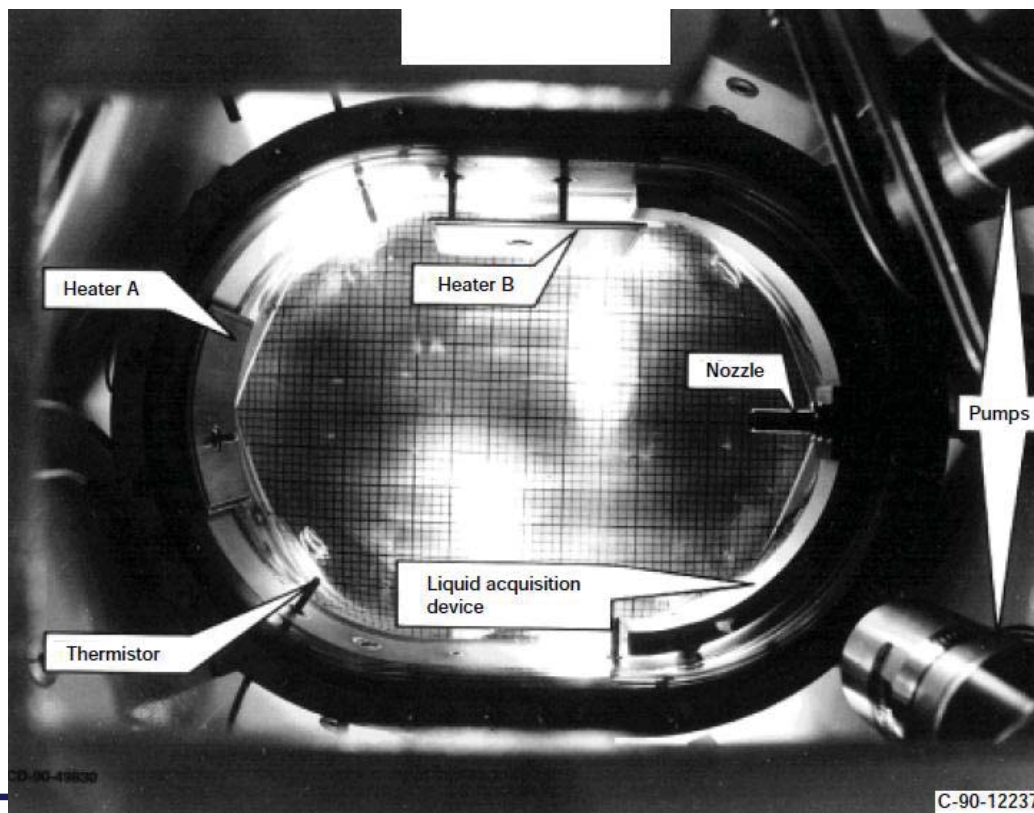

Figure 14.—Actual liquid-vapor configuration during flight experiment.



ISS SPHERES Slosh Experiment (subscale, non-cryo)

- Acquire low-gravity slosh data on ISS using SPHERES microsattellites to provide 6-DOF motion (12 cold-flow CO₂ thrusters, 0.11N each)
- Video of fluid motion (2 Basler Ace acA2500 5Mega pixel cameras), measure 6-DOF acceleration (2 CHR UM6 sensors)

Fluid = water
Fill level = 20%, 40%
Lexan Tank
Length = 30 cm
Diameter = 15 cm

Test Matrix:

- Settling Thrust (translate)
- Passive Thermal Control (rotate)
- Pitch to Reorient, Attitude Control (coupled translate, rotate)

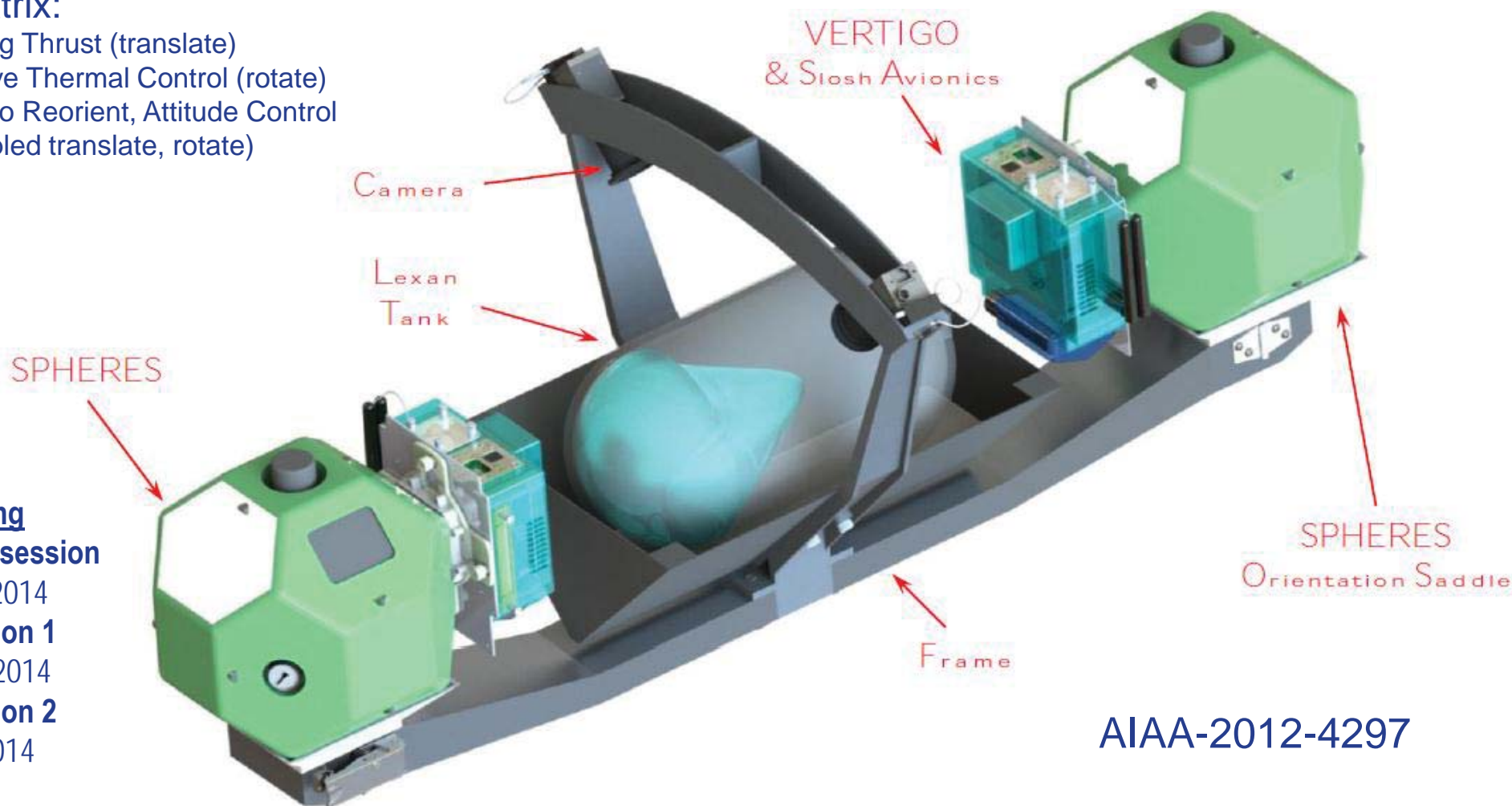

ISS Testing Checkout session

Jan 22, 2014

Test Session 1

Feb 28, 2014

Test Session 2

March 2014

AIAA-2012-4297



ISS ZBOT Experiment (subscale, non-cryo)

- PI= Mohammad Kassemi GRC/NCSSER; Co-PI= Dave Chato (GRC)
- Small-Scale ISS microgravity science experiments focusing on ZBO tank pressurization and pressure control
- Includes CFD model development and validation
- Simulant Fluid: **PnP** Transparent Dewar: **Acrylic**
- Accurate ullage pressure and liquid, ullage, and wall temperature measurements
- Particle Image Velocimetry (PIV) and liquid field flow visualization and full field interface capture
- Tightly controlled heat and flow boundary conditions
- Hierarchical series of experiments planned:

ZBOT1- *Pressurization, Fluid Mixing, Destratification*
(Launch Aug 2015)

ZBOT2- *Noncondensables Gas Effects*

ZBOT3- *Active Cooling: spray-bar, subcooled jet mixing, and broad-area wall cooling*

HEOMD /
Physical Science
Research Program

ZBOT Engineering Unit in MSG Mockup

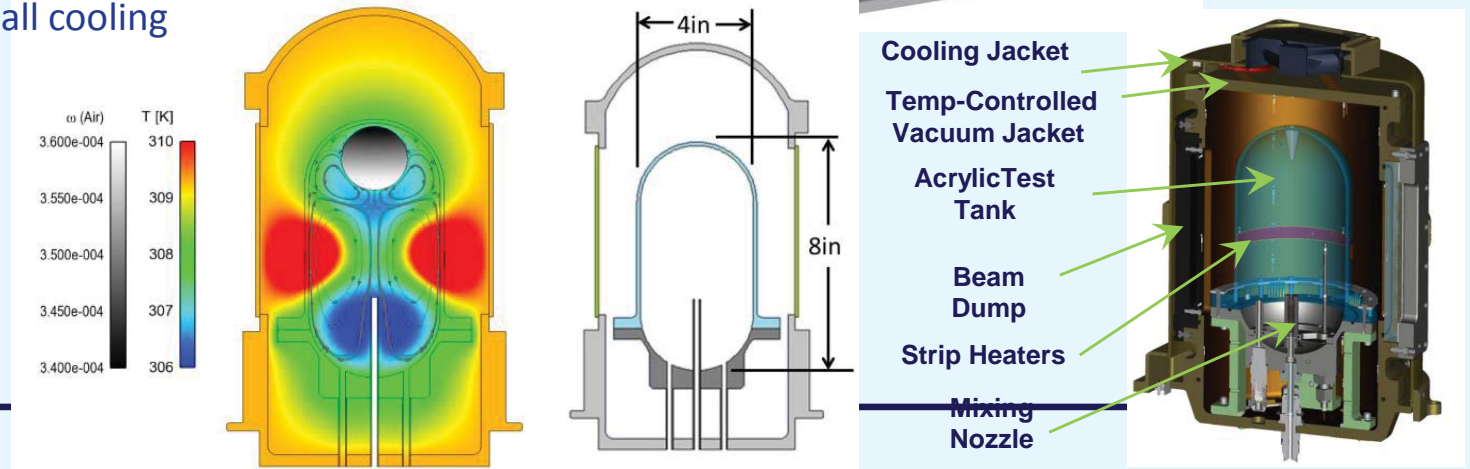
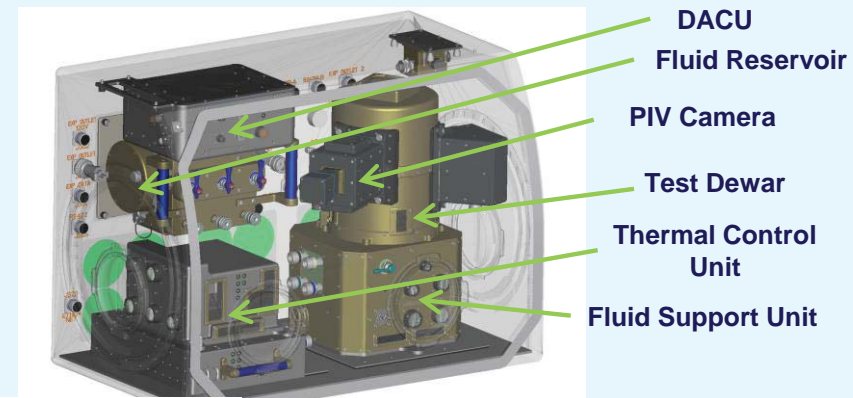
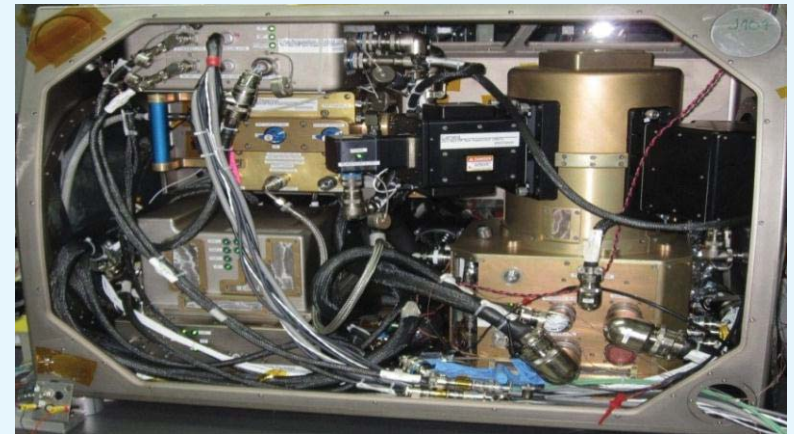

Example CFD Application

CFD simulation of axial jet pressure control for CPST LH2 Storage tank (D=1.7m, H=2.3m) in LEO under general time-varying acceleration conditions (based on Oct 2011 Gov POD spacecraft)

1 inch (2.54cm) nozzle. 4.53 GPM LH2 jet flow rate ($We_J = 4.5$). 440,000 cell grid.

Time step= 0.001sec. Duration=600 sec (10 min). Simulation time= 1week (using 32 processors)

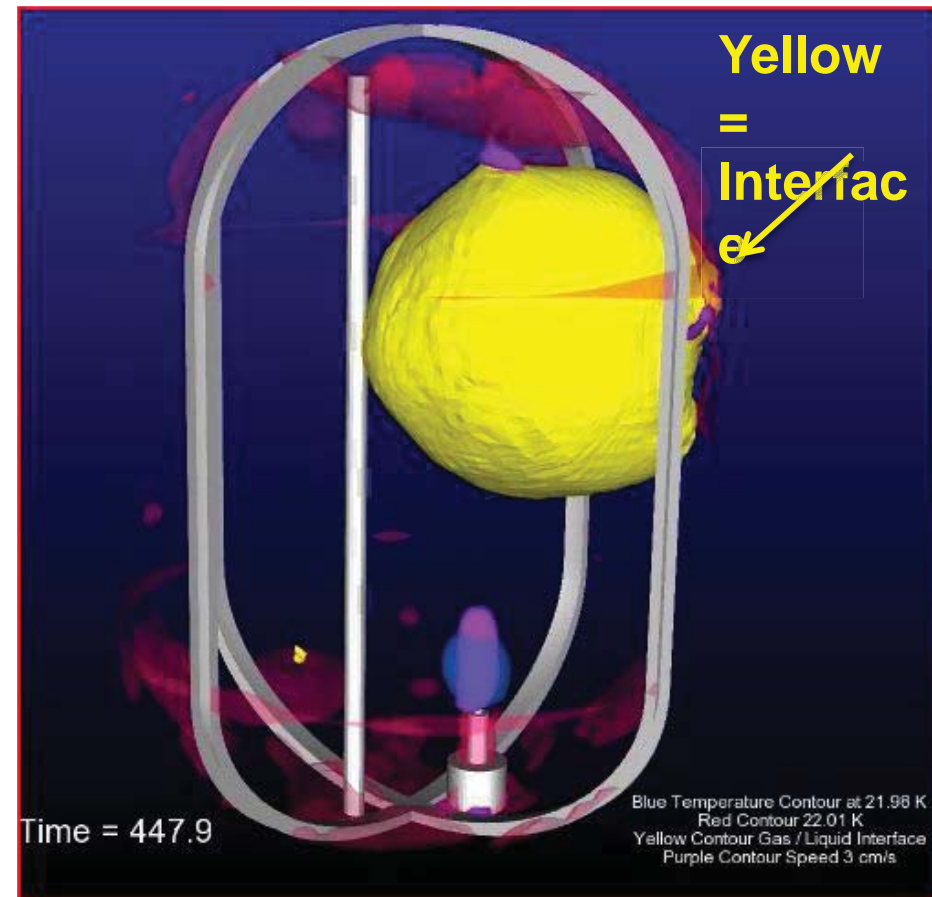
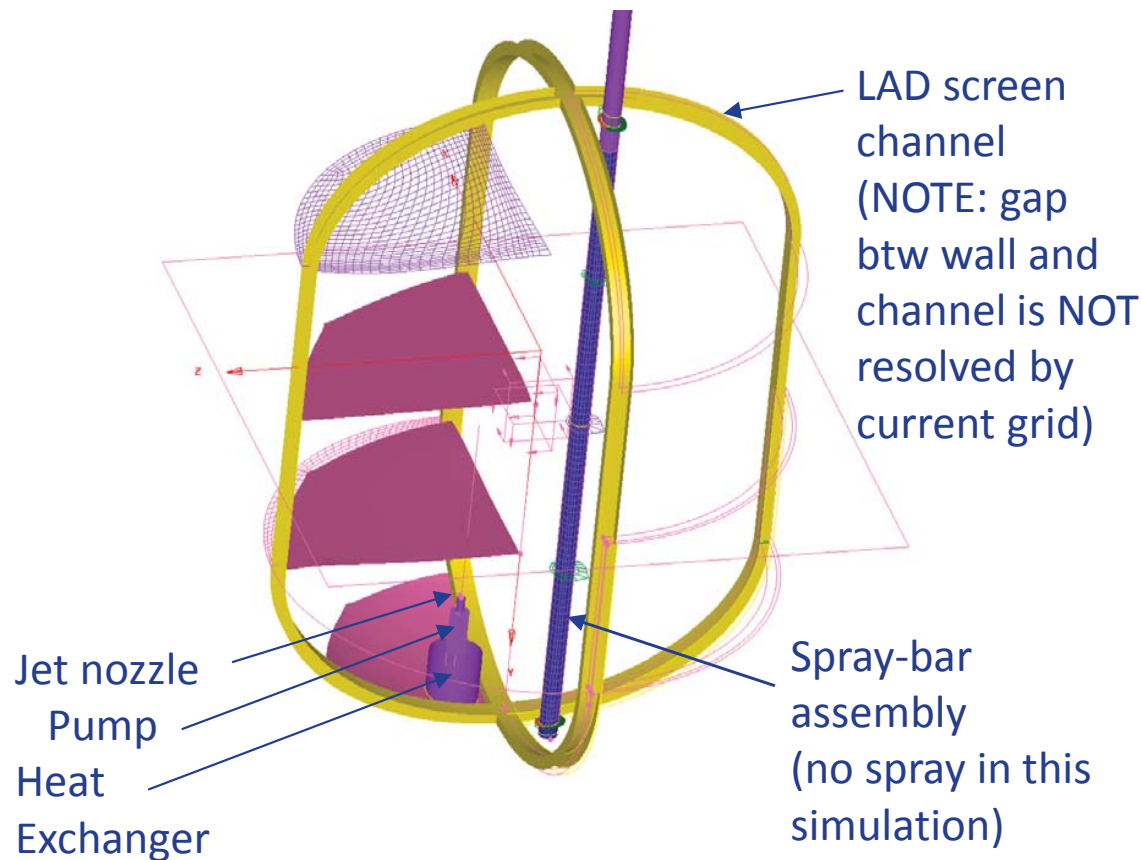



Multinode Analysis



TankSIM and CPPPO



TankSIM and CPPPO Overview

TankSIM: NASA MSFC Fortran code.

CPPPO: NASA MSFC Excel VBA code

TankSIM consists of 8 nodes. CPPPO consists of 7 nodes (1-7):

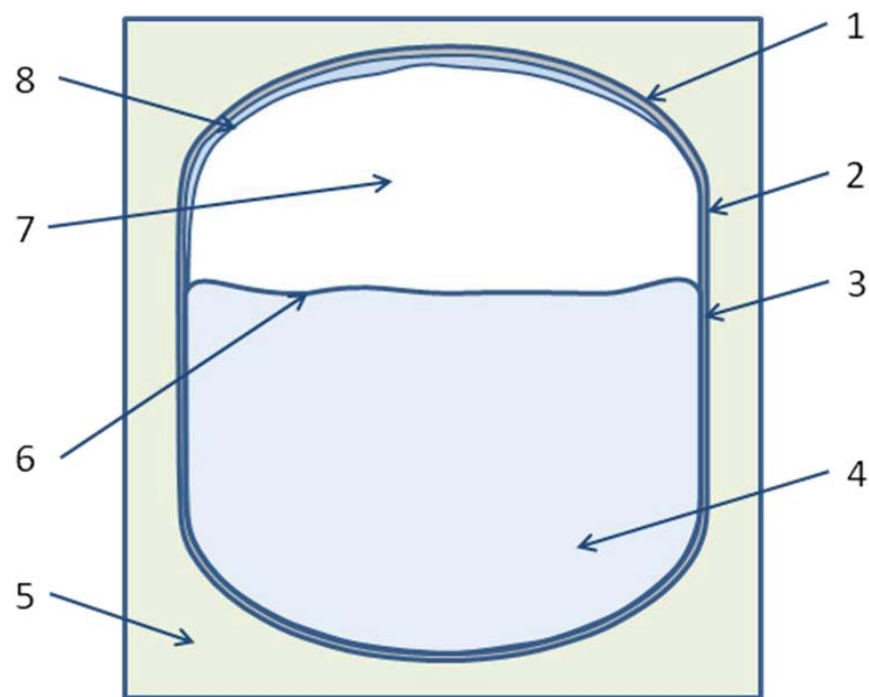

1. Ullage tank wall - upper head part
3. Bulk liquid tank wall
5. Environment
7. Ullage

2. Ullage tank wall - cylindrical part
4. Bulk Liquid
6. Ullage - liquid interface
8. Tank wall liquid (from spray bar)

TankSIM and CPPPO Technical Description

The following schematic describes quantities used in mass and energy conservation equations, and for heat and mass transfer:

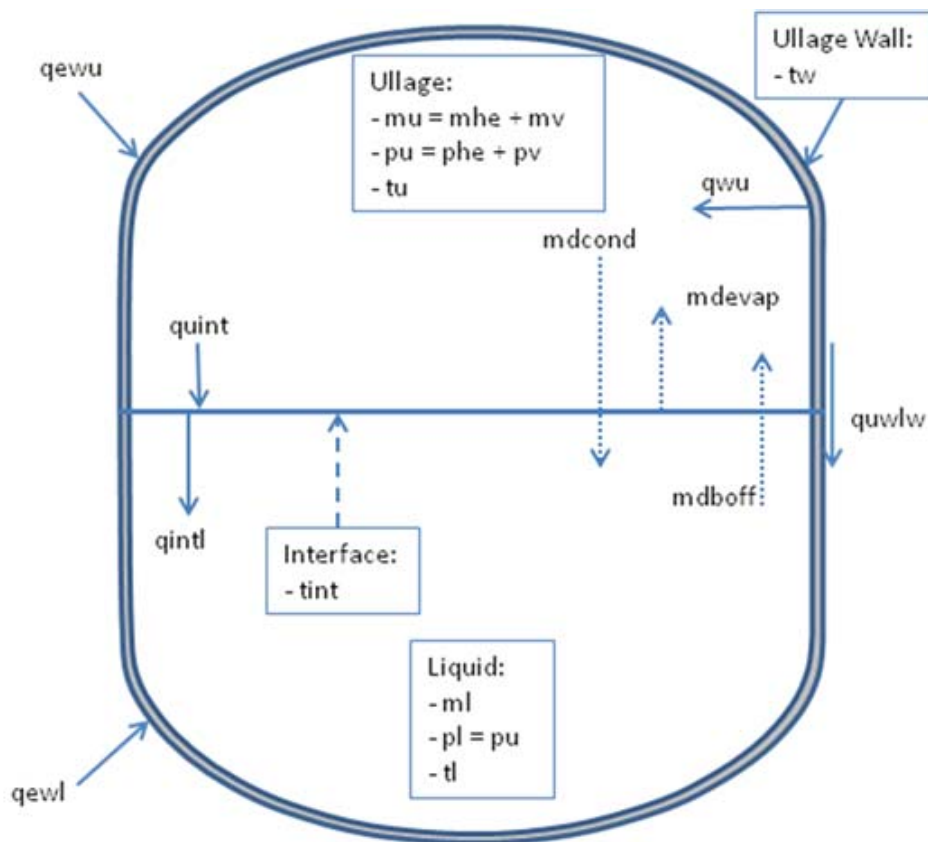

- Real fluid properties (NIST RefProp and table lookup) used for liquid and gas properties
- Finite Difference equations for mass and energy in liquid and ullage
- Finite Difference energy equation for wetted and dry tank wall
- TankSIM include spray-bar and axial jet TVS analysis.
- Mass transfer across liquid/ullage interface based on energy jump condition
- Validated for settled conditions

$$(\vec{q}_{L,i} - \vec{q}_{u,i}) \cdot \hat{n}_i = J_{evap} (h_{v,i} - h_{L,i})$$

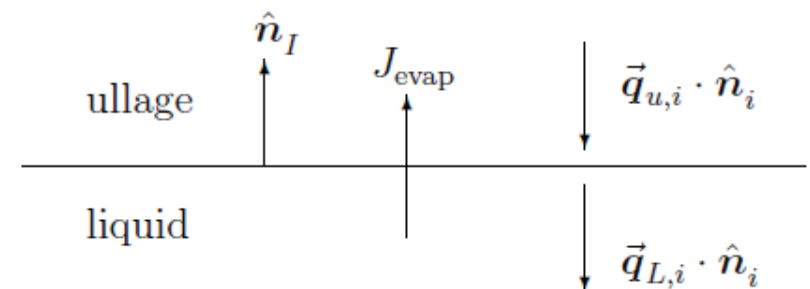



TankSIM Validation against MHTB spray bar TVS

MHTB, Methane, 90 % fill level:

- Heat loads: total – 620.0 W; ullage – 102.5 W; liquid – 600.0 W; uniformly distributed – 17.5 W;
- Initial temperatures: ullage – 105.35 K; liquid – 103.9 K; ullage-wall – 105.0 K;
- Initial ullage pressure – 165.0 kPa.

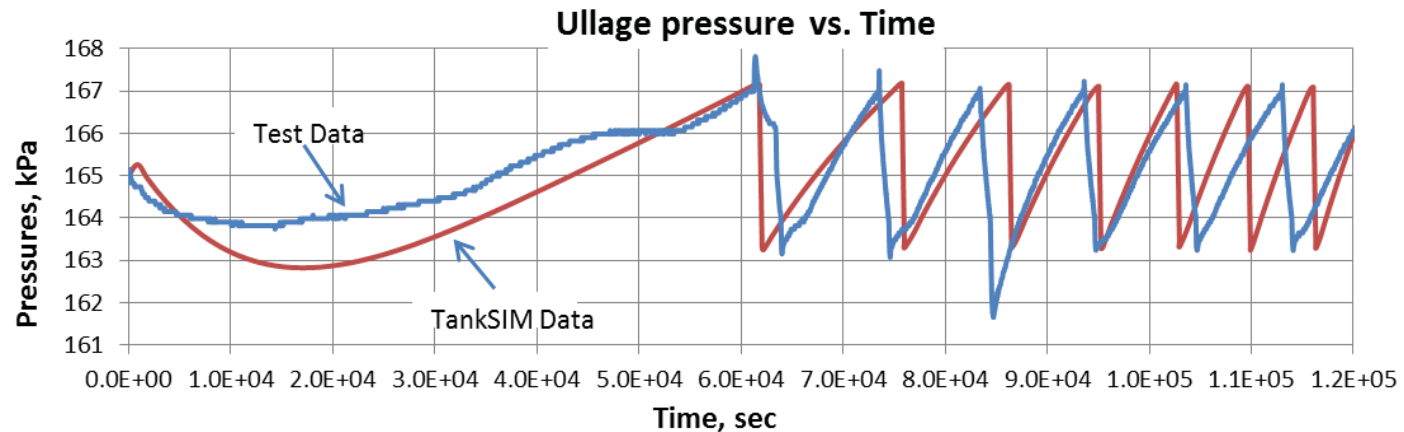

Validation issues:

- Average values from the temperature measurements. TankSIM uses special program for weighted averaging experimental data at each time step;
- Strong dependency from external heat distribution even with the same total heat load. Usually, heat loads distribution given by experiments are very approximate;
- Accuracy of pressure measurements at cryogenic temperatures.



GFSSP



GFSSP Summary

- GFSSP is a general-purpose finite-volume based multi-node (flow network) code for steady and time-dependent flows, including modeling phase changes, conjugate heat transfer, compressibility, mixture thermodynamics, and external body forces such as gravity and centrifugal.
- Twenty-one different resistance/source options are provided for modeling momentum sources or sinks in the branches.
- Two thermodynamic property programs (GASP/WASP and GASPAK) provide required thermodynamic and thermo-physical properties for thirty six fluids
- GFSSP development started at MSFC in 1994 and current release is Version 6.05
- User Manual and other documentation is available at <https://gfssp.msfc.nasa.gov/links.html>
- GFSSP is available free of cost for Government use from MSFC Tech Transfer Office after completing the necessary paperwork
- Training Class is offered is offered at TFAWS
- Mathematical Formulation, Validation and Application cases are presented, with an emphasis on cryogenic applications.

Network Definition

GFSSP Flow Network consists of:

- Internal Node
- Boundary Node
- Branch
- Solid Node
- Conductors
- Ambient Node

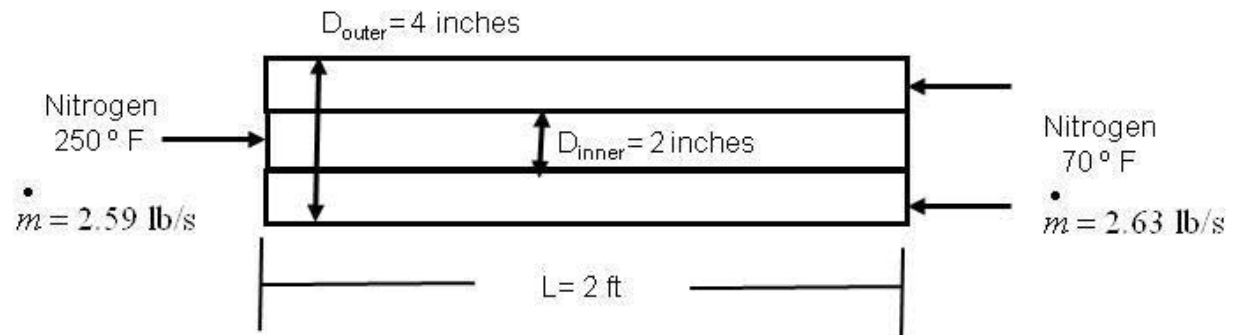
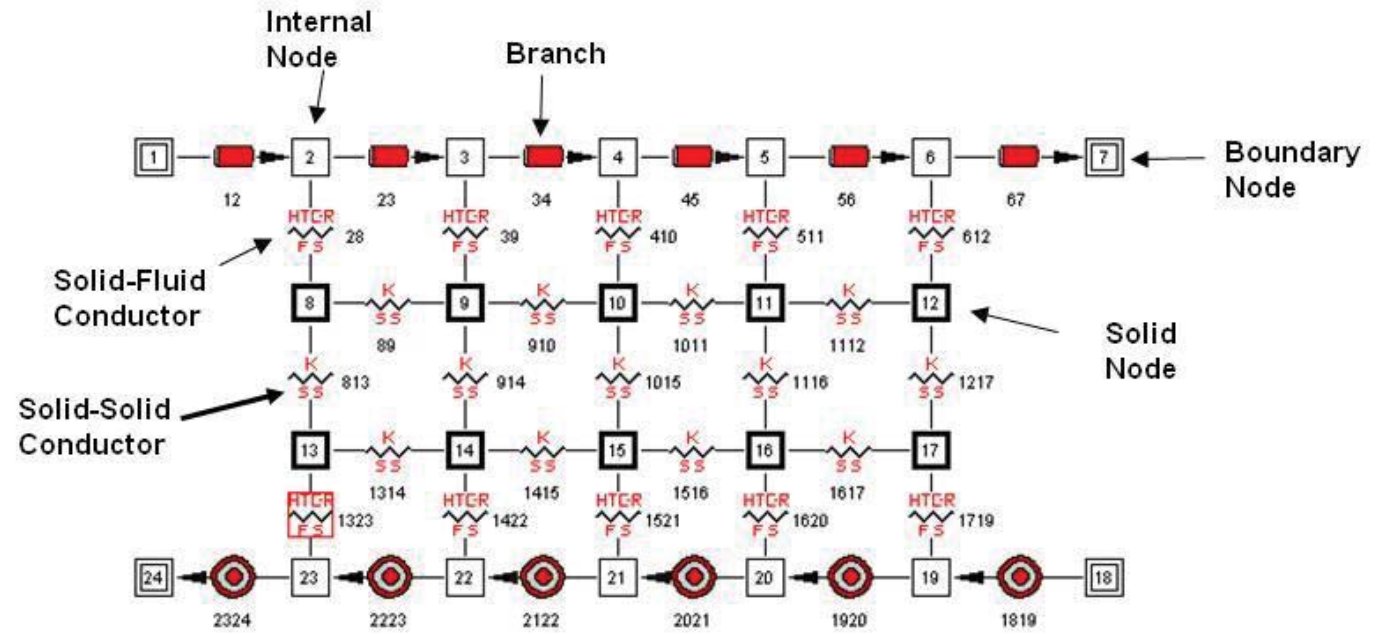



GFSSP Program Structure

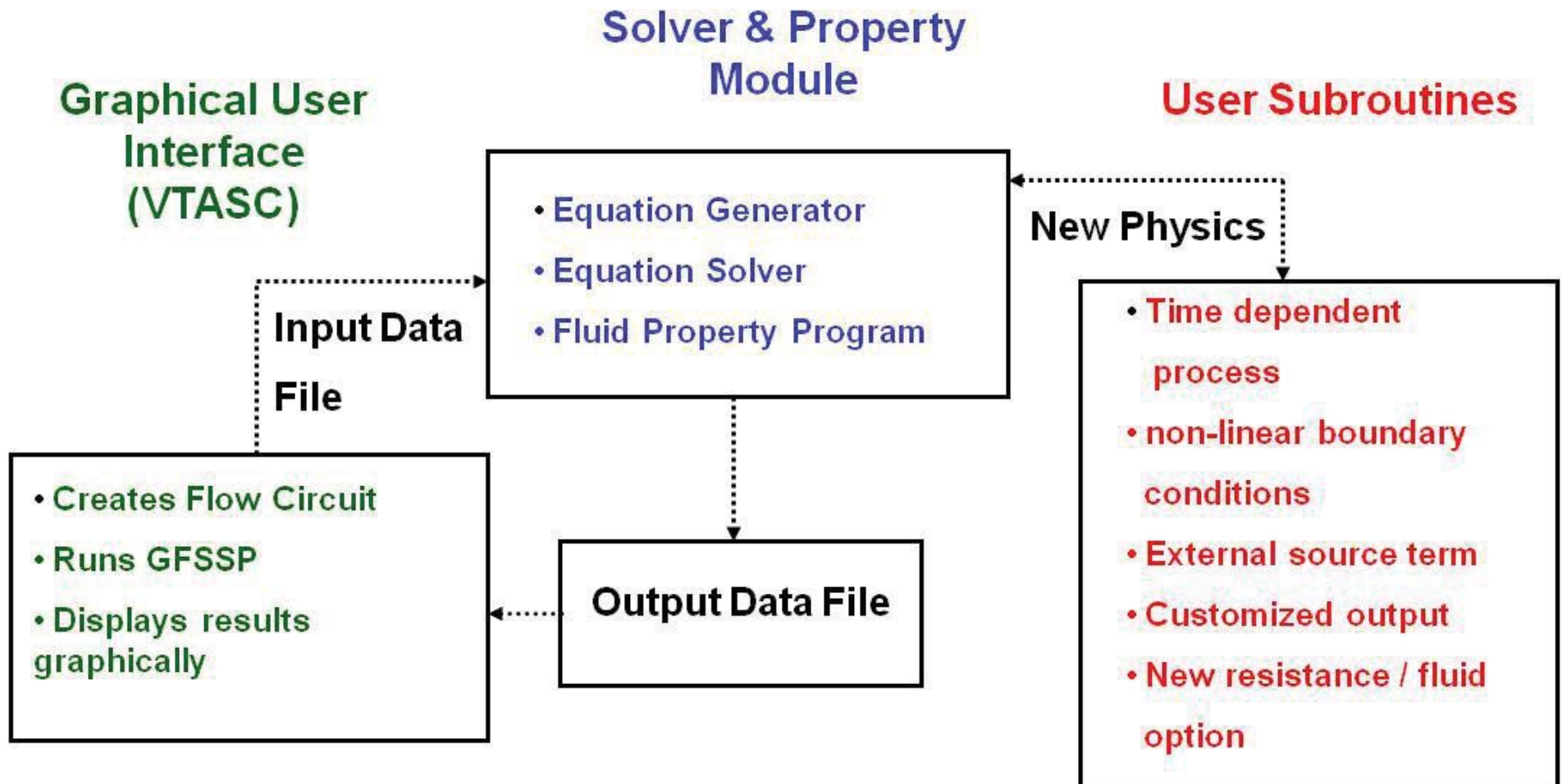



GFSSP Mathematical Formulation

Principal Variables:

Unknown Variables

1. Pressure

2. Flowrate

3. Fluid Temperature

4. Solid Temperature

5. Specie Concentrations

6. Mass

Available Equations to Solve

1. Mass Conservation Equation

2. Momentum Conservation Equation

3. Energy Conservation Equation of Fluid

4. Energy Conservation Equation of Solid

5. Conservation Equations for Mass Fraction of Species

6. Thermodynamic Equation of State



GFSSP Finite Volume Solver

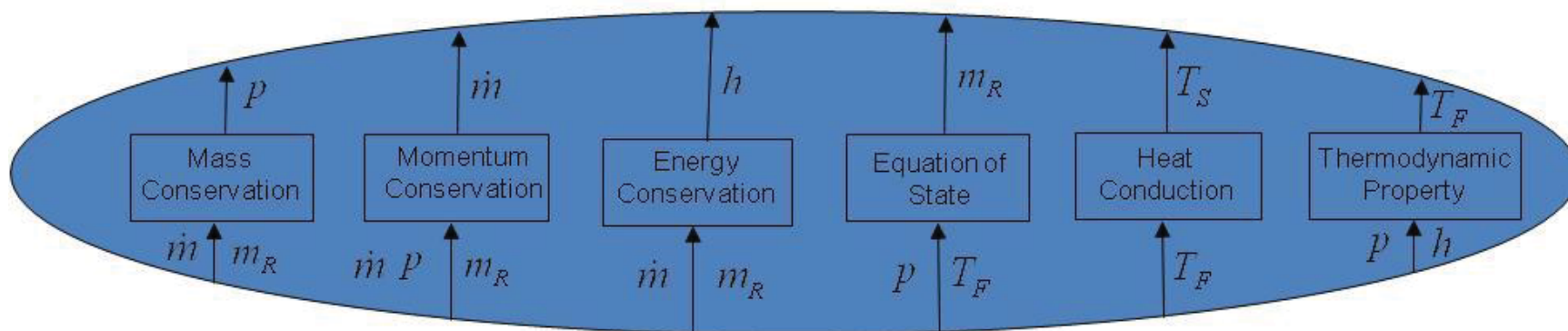

GFSSP Iteration Cycle

p - Pressure \dot{m} - Flowrate T_F - Fluid Temperature
 m_R - Resident Mass h - Enthalpy T_S - Solid Temperature

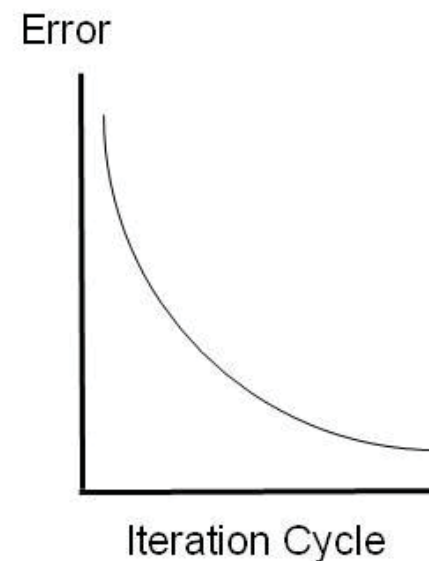



Validation Cases

- Propellant Loading of Space Shuttle
- NBS H2 Line Chillover
- VATA-Cryote Transfer/Chill/Fill
- Propellant Boil-off

- K-site H2 Tank Chillover/Fill
- MHTB LH2 Tank Self-pressurization and TVS

GFSSP Validation against 1g LH2 K-site Chillydown

■ K-site Test Tank - LH2 chillydown test was run on February 15, 1991

Tank Material – 2219 Aluminum

Tank Volume = 175 ft³ (87 x 72.5 inch)

Tank Weight = 329.25 lbs

Tank Insulation – 34 layers of MLI

Chillydown Method:

- 6 Cycles of Charge-Hold-Vent Process
- Injection rates were measured
- 714.35 lbs of LH2 was injected in 2.35 hrs
- Tank was filled to 94%
- Fluid and wall temperatures measured
- Estimated consumption of LH2 = 32 lbs

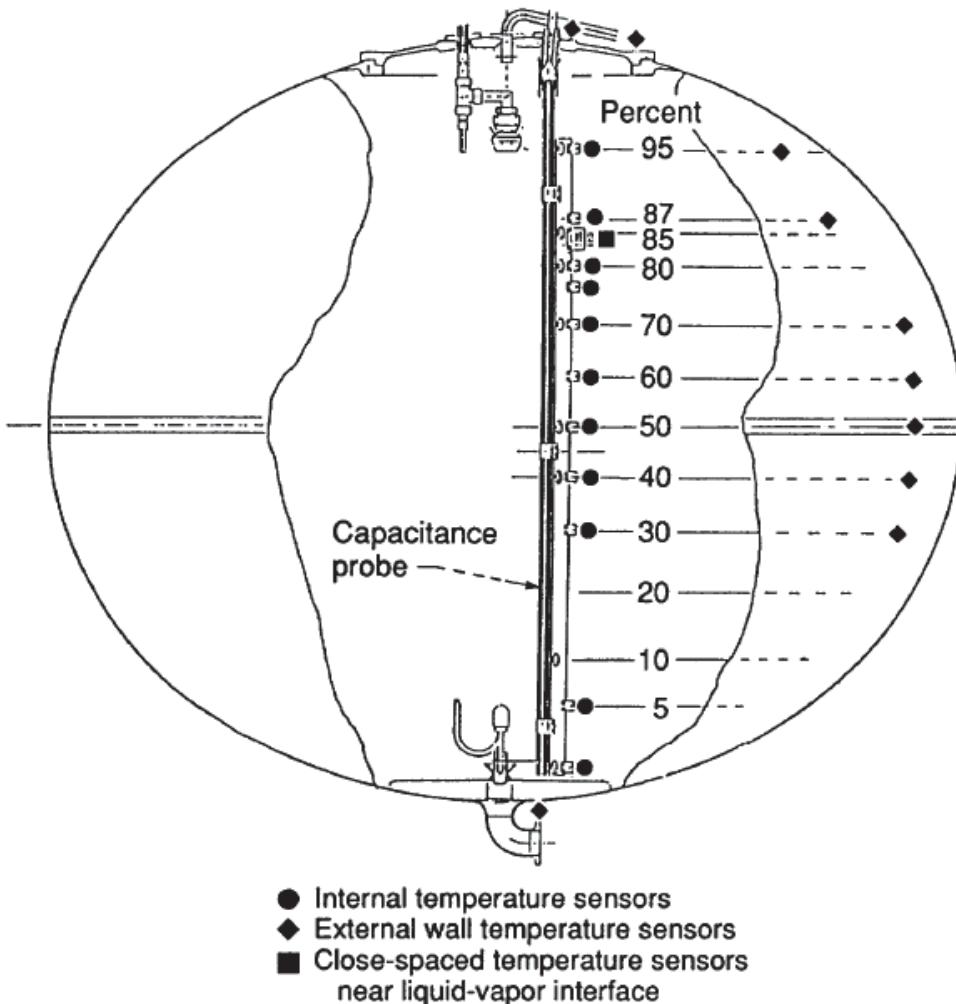

Figure 6.—Tank instrumentation.



GFSSP Validation against 1g LH2 K-site Chillydown

Nine Nodes for fluid and nine nodes for tank wall

Propellant Mass Loss during tank chillydown/fill test:

Predicted: 32.5 lbs (9-node) & 33.5 lbs (1-node)
 Test Data: 32 lbs

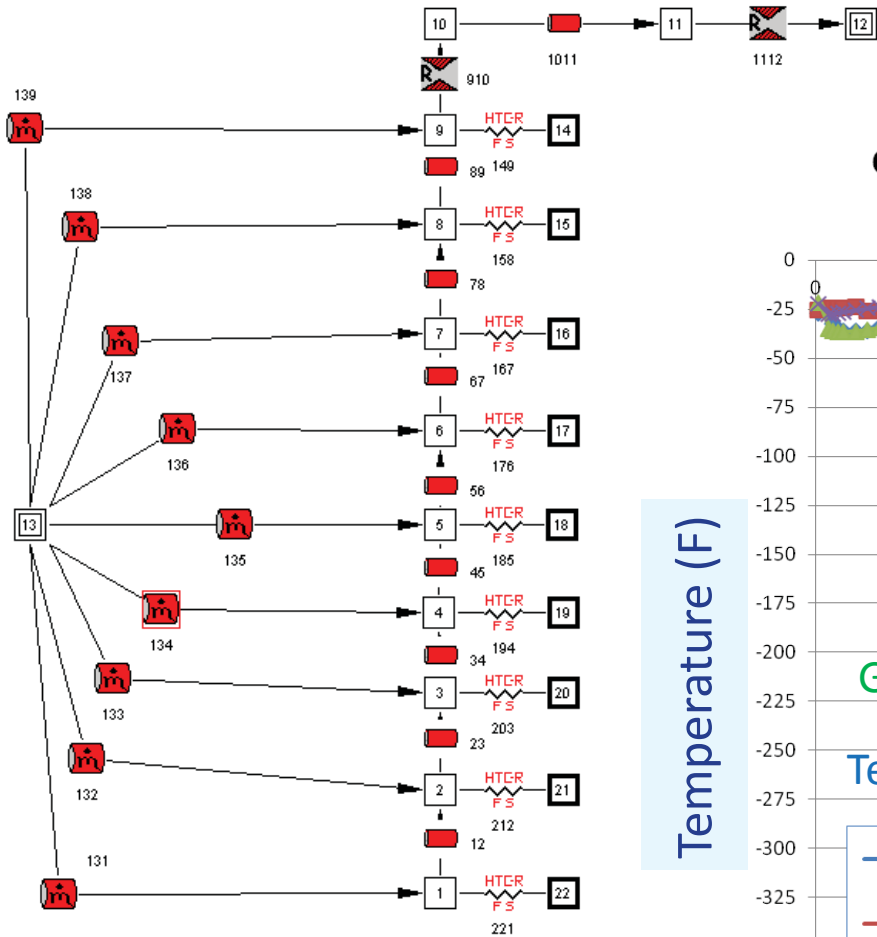

GFSSP (Single Node) and GFSSP (9 Node Centerline) Wall Temperature Results Comparison to Test Wall Temperature Results

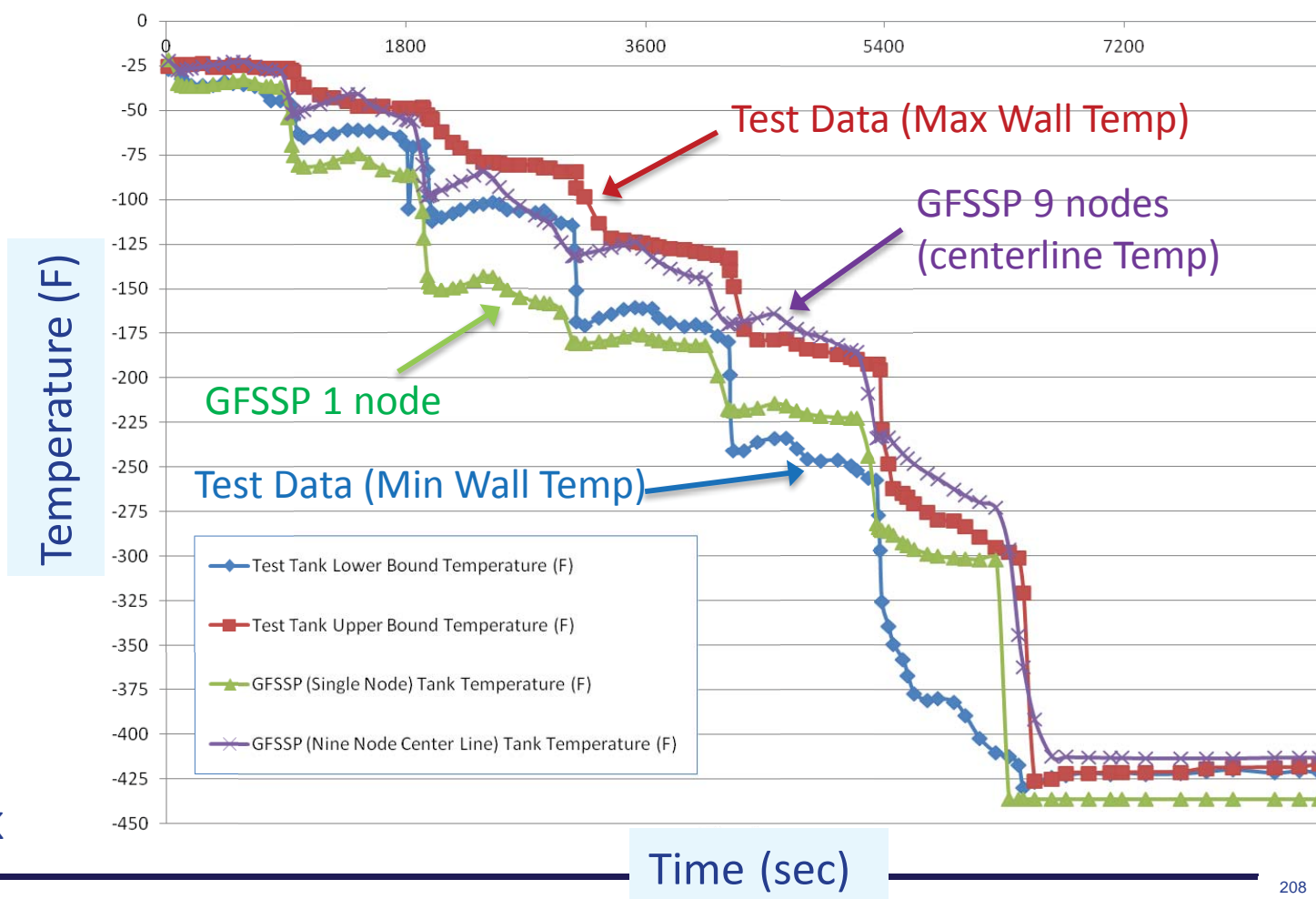

- Tanks walls treated as adiabatic
- Initial Tank Pressure = 2 psia
- Initial Tank Temperature = 244 K

Time (sec)

GFSSP Integrated Systems Model of MHTB LH2 TVS

- GFSSP integrated systems model of passive thermal control (MLI and SOFI insulation) and active pressure control (spraybar-based thermodynamic vent system (TVS))
- Use 1998 MHTB LH2 50% experiments to anchor model.
- Multi-node ullage model
- Develop a Subroutine to model heat transfer through MLI and SOFI

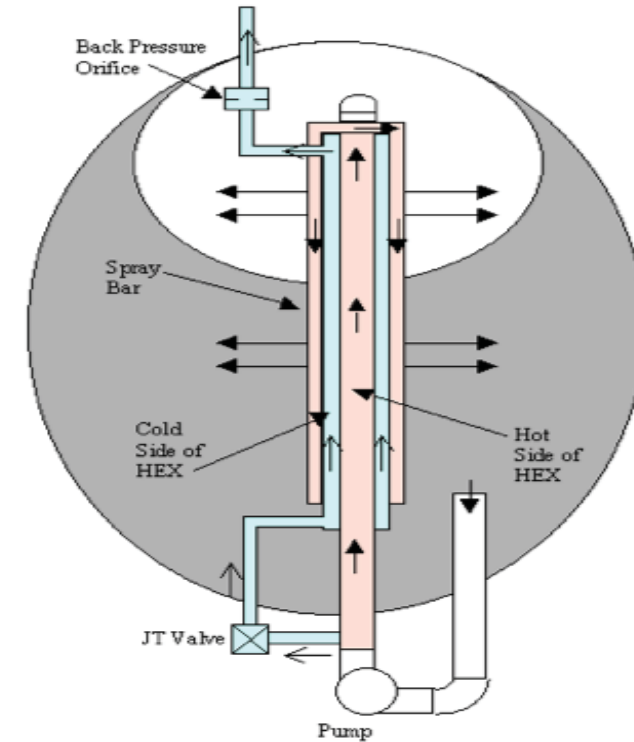
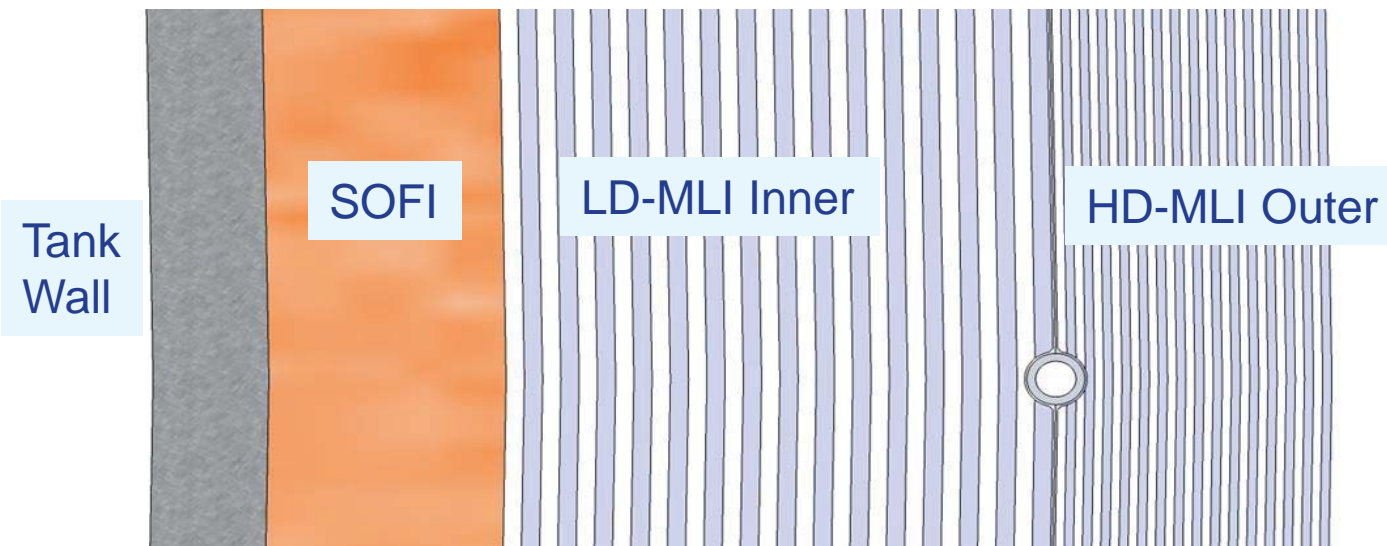

MHTB Spray Bar TVS

Modified Lockheed Equation: NASA/TM-2004-213175, Hastings, L. J., Hedayat, A., and Brown, T. M., *Analytical Modeling and Test Correlation of Variable Density Multilayer Insulation for Cryogenic Storage*, NASA/MSFC, May 2004.

$$q = \left[\frac{C_s (0.017 + 7.0E - 6 * (800.0 - T_{avg}) + 2.28E - 2 * \ln(T_{avg})) (N^*)^{2.63} (T_h - T_c)}{N_s} + \frac{C_r \varepsilon (T_h^{4.67} - T_c^{4.67})}{N_s} + \frac{C_g P (T_h^{0.52} - T_c^{0.52})}{N_s} \right]$$



GFSSP Integrated Systems Model of MHTB LH2 TVS

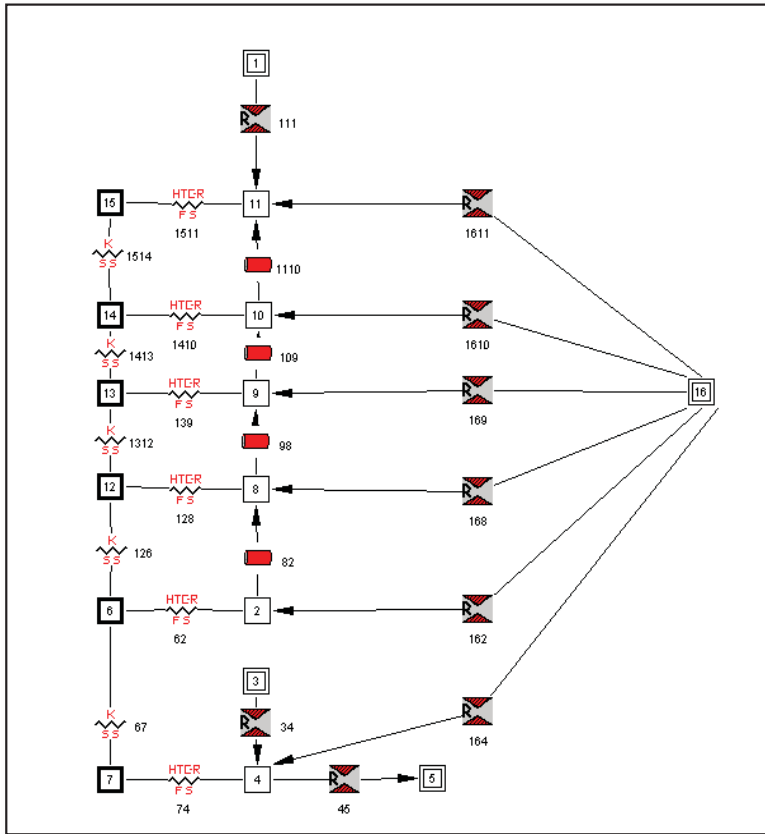

- GFSSP model compare favorably to existing CFM models (CryoSIM and TankSIM)
- MLI model shows good correlation to self pressurization test data using a degradation (or scale) factor of 2.8.
- MLI model predicts total heat load of 51.8 W comparable to 51 W calculated from test data.

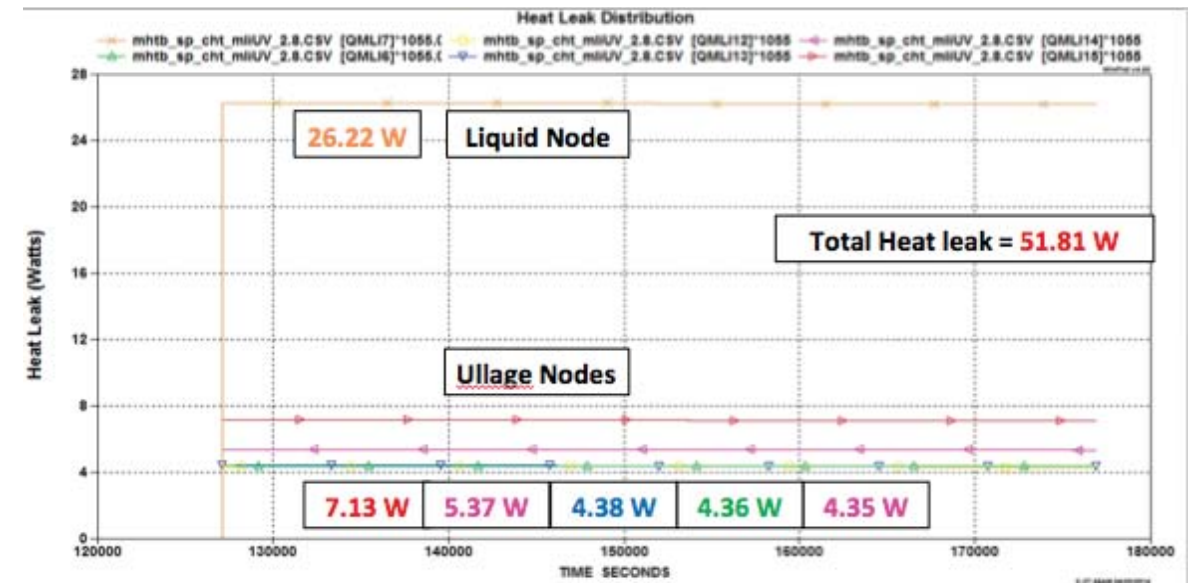
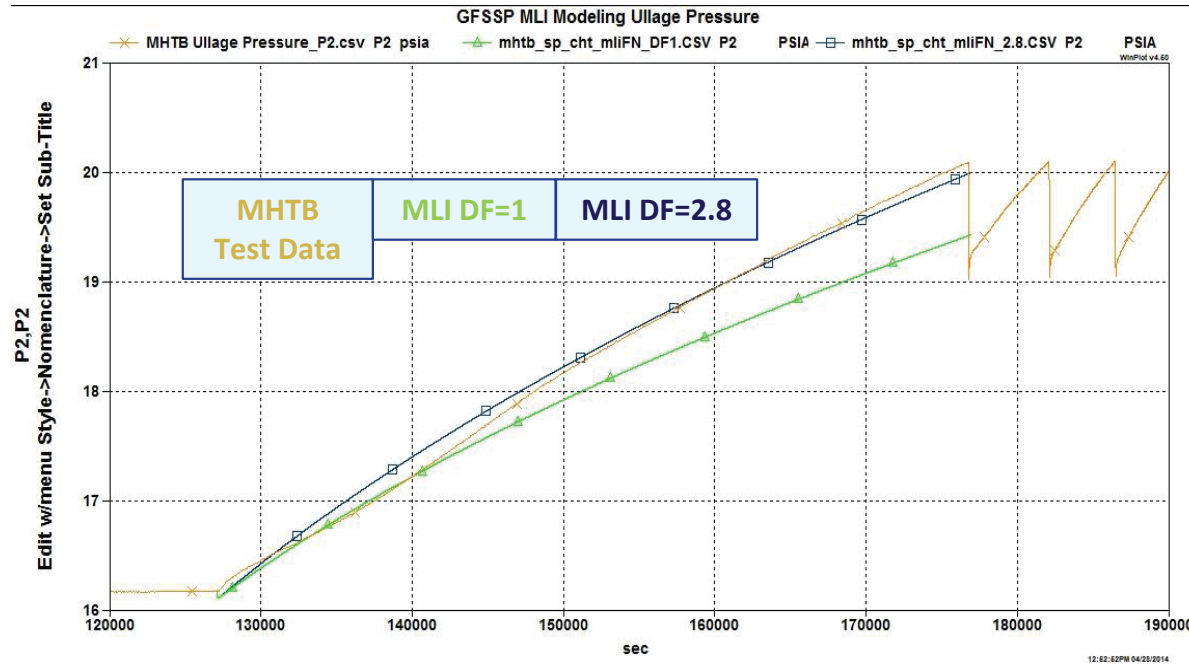



SINDA/FLUINT



SINDA/FLUINT Summary

- SINDA/FLUINT is a commercial general purpose thermal/fluid system analysis code. The current version is 5.6. (www.crtech.com)
- Supports single phase, liquid/vapor mixtures, chemical reactions.
- Any working fluid (real/ideal gas, compressible) with adequately defined properties can be utilized. 20 refrigerants are immediately available, and the user may describe properties of additional gases, liquids, and two-phase fluids with reusable FPROP DATA BLOCKS (for cryogenic fluids, fire retardants, fuels and propellants, and other heat transfer fluids).
- Two graphical interfaces are available
 - A nongeometric sketchpad-style Sinaps[®].
 - A geometry-based Thermal Desktop[®] (for SINDA conduction/capacitance calculations based on finite elements and/or finite differences) with its companion modules RadCAD[®] (SINDA radiation calculations) and FloCAD[®] (FLUINT circuits, heat pipes, and convective heat transfer calculations).
- Development and validation a customized user defined coding is presented for self-pressurization and axial jet mixing
- Example applications are shown for analysis of axial jet TVS cycles and design of an axial jet TVS heat exchanger (both for a ground test article)



Customization for Cryogenic Tank Analysis

- A general purpose SINDA/FLUINT (S/F) stratified tank model was created to simulate self-pressurization and axial jet TVS
- Stratified layers in the vapor and liquid are modeled using S/F lumps.
- The stratified tank model was constructed to permit incorporating the following additional features:
 - Multiple or singular lumps in the liquid and vapor regions of the tank
 - Real gases (also mixtures) and compressible liquids
 - Venting, pressurizing, and draining
 - Condensation and evaporation/boiling
 - Wall heat transfer
 - Elliptical, cylindrical, and spherical tank geometries
- Extensive user logic is used to allow tailoring the above features to cases
- Most code input for a specific case is done through the Registers Data Block.



K-Site LH2 Self-Pressurization (1g)

1. Flightweight insulated aluminum ellipsoidal tank
 - Internal volume: 175 ft³
 - Tests conducted in vacuum chamber.
 - Tank is supported by 12 fiberglass composite struts.
 - Test article is enclosed by a cryoshroud whose temperatures are maintained with electrical heaters.
 - Tank insulated with 2 blankets of MLI.
2. Test fluid is liquid hydrogen
3. Steady boil-off test and measurement performed at 95% fill and 117 kPa.
4. Tank fill level was reduced to desired fill level.
5. Several hours of additional venting at 103 kPa to achieve stationary state.
6. Self-pressurization tests were initiated from stationary stratified state.

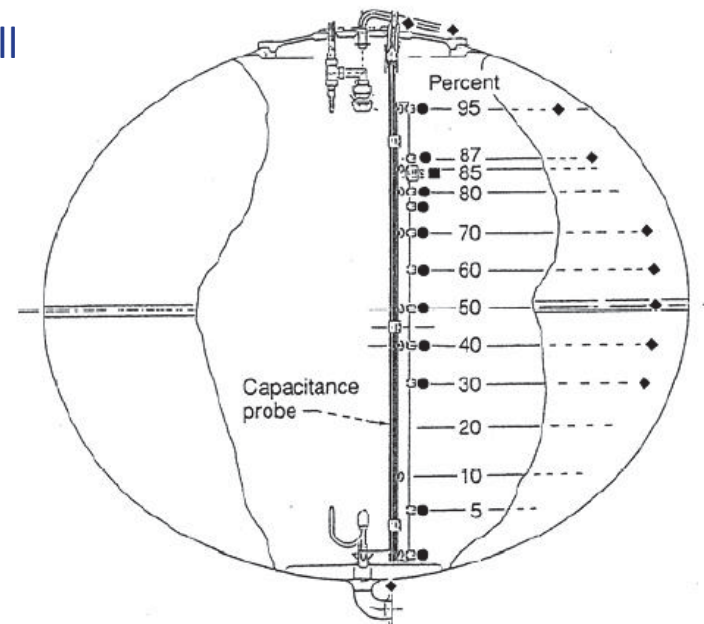
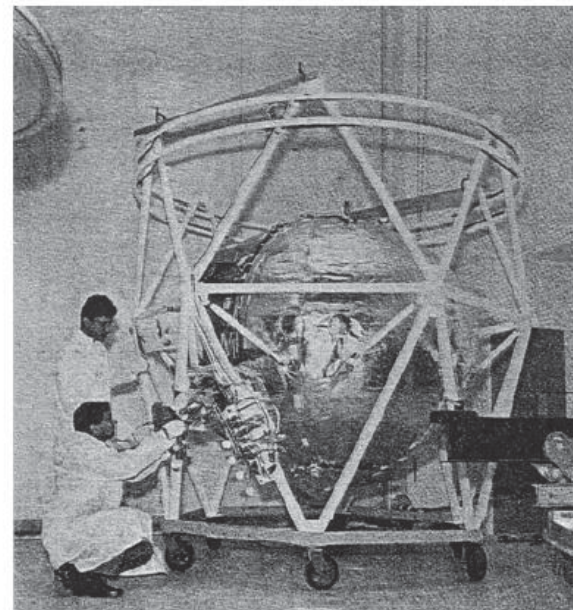

NASA TM-103804, 1991 and NASA TM-105411, 1992



K-site LH2 1g Self-pressurization: Experimental and SINDA/FLUINT

RESULTS

SINDA/FLUINT used 50 LIQUID LUMPS, 40 VAPOR LUMPS

29% Liquid Fill Level. Total Heat into Tank = 30 W

Fluent = lumped ullage model

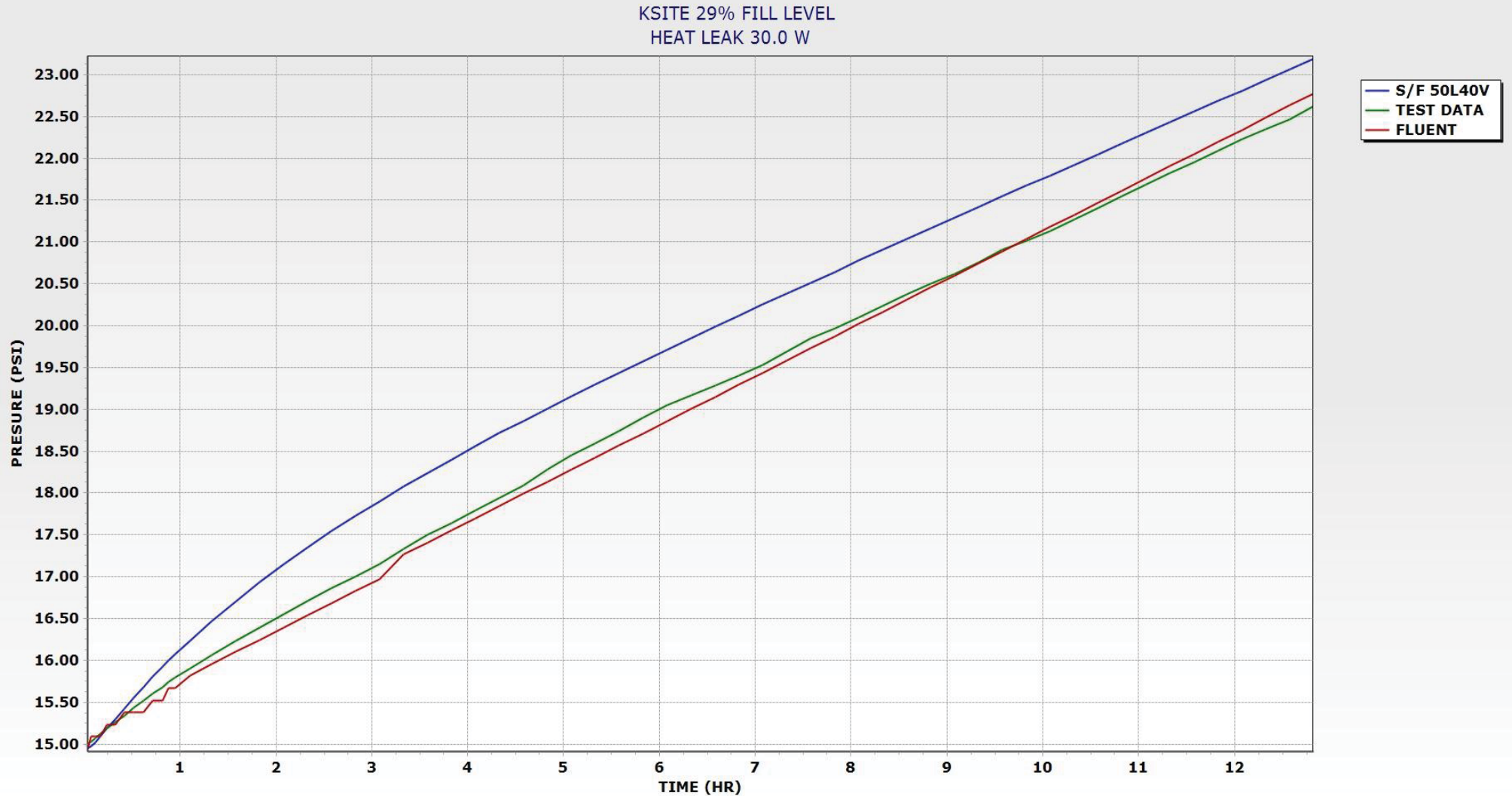



K-site LH2 1g Self-pressurization: Experimental and SINDA/FLUINT

RESULTS

SINDA/FLUINT used 50 LIQUID LUMPS, 40 VAPOR LUMPS

29% Liquid Fill Level. Total Heat into Tank = 49.35 W

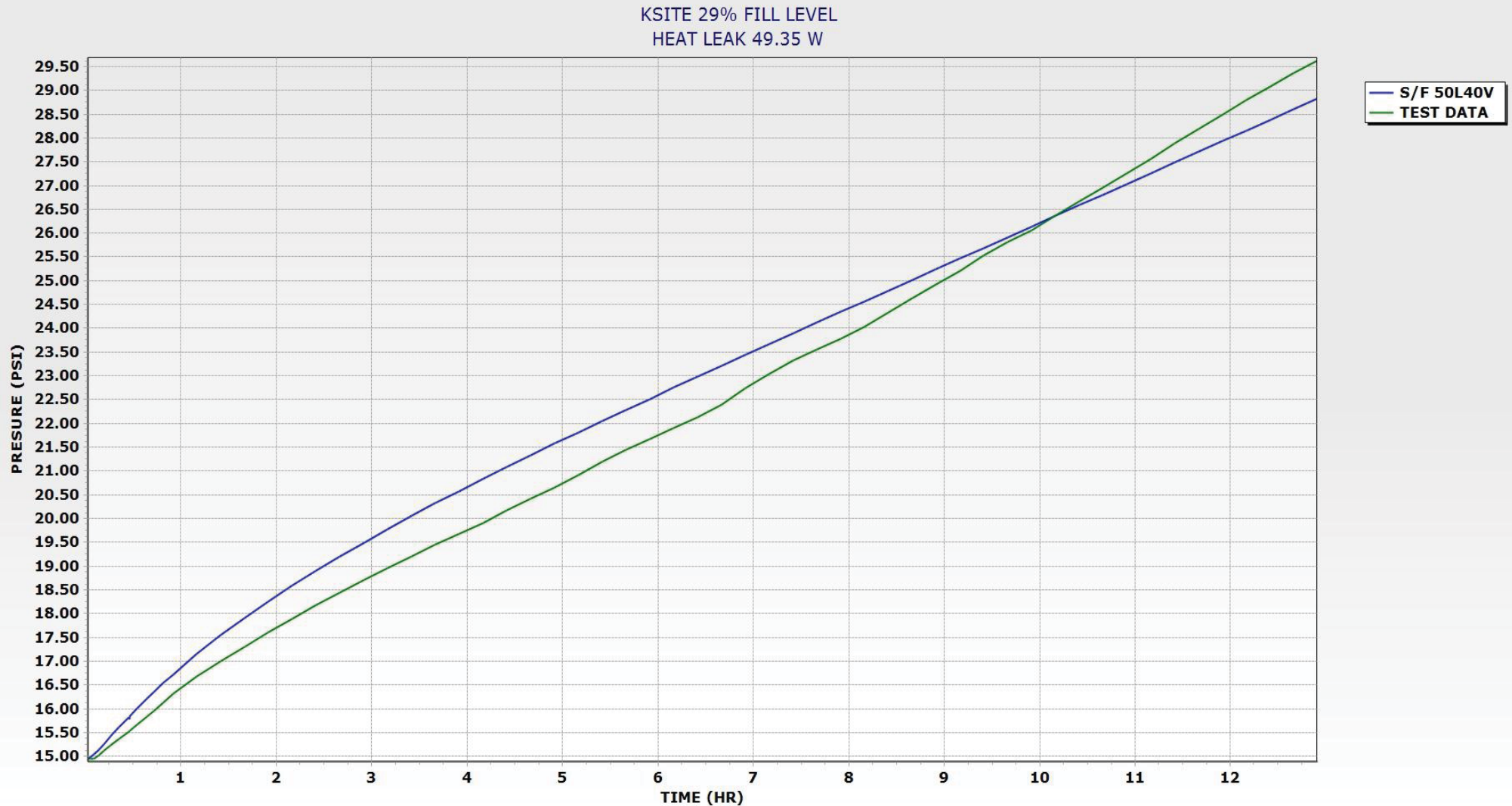



K-site LH2 1g Self-pressurization: Experimental and SINDA/FLUINT

RESULTS

SINDA/FLUINT used 50 LIQUID LUMPS, 40 VAPOR LUMPS

49% Liquid Fill Level. Total Heat into Tank = 30 W

Fluent = lumped ullage model





K-site LH2 1g Self-pressurization: Experimental and SINDA/FLUINT RESULTS

SINDA/FLUINT used 50 LIQUID LUMPS, 40 VAPOR LUMPS

49% Liquid Fill Level. Total Heat into Tank = 49.35 W

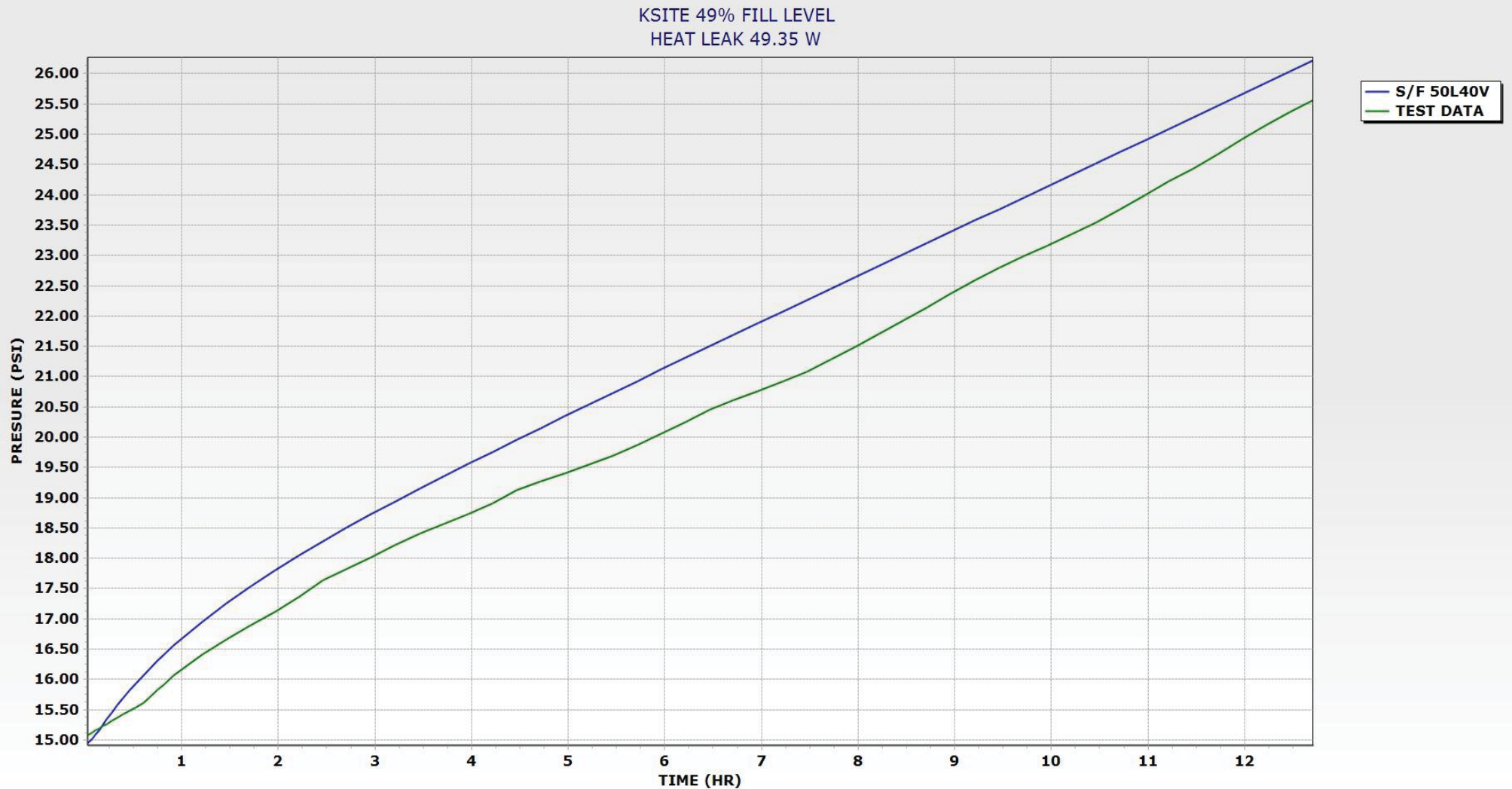

K-site LH2 Axial Jet Experiments (1g)

- Same Tank as K-site LH2 1g Self-pressurization experiments. Pump and jet nozzle (mixer unit) was hardware designed for Shuttle Centaur LH2 tank and installed in K-site LH2 tank.
- Jet nozzle and location not changed during axial jet runs, but the jet flow rate was varied.
- Only considering test runs where self-pressurization was used to pressurize tank before turning on jet (Test Series A and B). Tank typically pressurized to 186 kPa before initiating jet.
- Experimental data is available for:
 tank heat load,
 ullage pressure,
 fluid temperature
 rake,
 wall temperatures,
 jet flow rates.

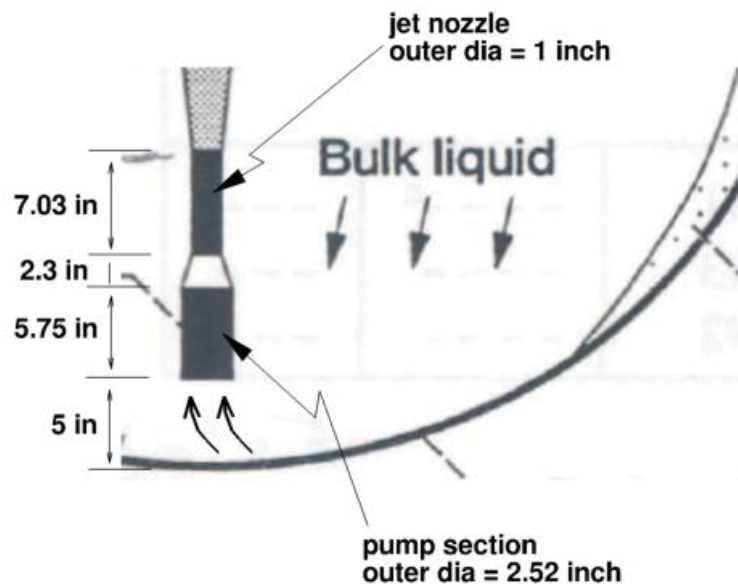



K-site LH2 Axial Jet: Test Runs Simulated

Table 1: Experimental conditions for mixing tests.

Test run #	Initial liquid fill, %	Jet volume flow rate, m ³ /hr	Jet velocity, m/s	Re _{jet}	Initial pressure, kPa
436	85.3	1.82	1.32	160,000	187.0
434	86.3	3.47	2.51	304,000	186.1
457	49.1	1.82	1.33	161,000	186.5
449	49.1	3.41	2.47	299,000	186.1

1.82 m³/hr = 8.0132 GPM LH2

3.41 m³/hr = 15.0138 GPM LH2

3.47 m³/hr = 15.278 GPM LH2

Essentially 2 fill levels and 2 jet flow rates



K-site LH2 1g Axial Jet: Experiment and SINDA/FLUINT

SINDA/FLUINT used 75 LIQUID LUMPS, 50 VAPOR LUMPS

Test Run 436 (85.3% liquid fill, 8.0132 GPM LH2 jet flow rate)

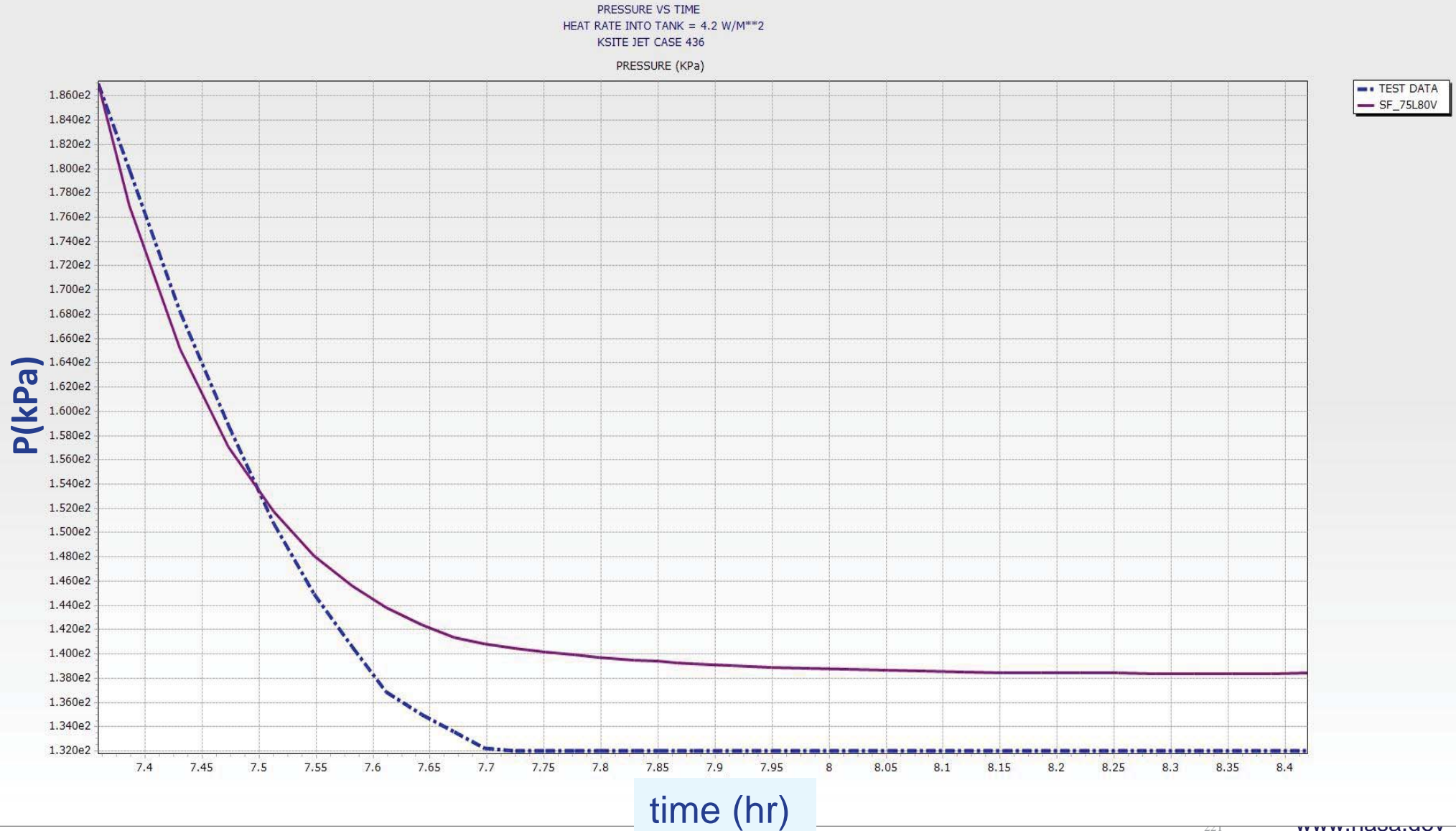



K-site LH2 1g Axial Jet: Experiment and SINDA/FLUINT

SINDA/FLUINT used 75 LIQUID LUMPS, 50 VAPOR LUMPS

Test Run 434 (86.3% liquid fill, 15.278 GPM LH2 jet flow rate)

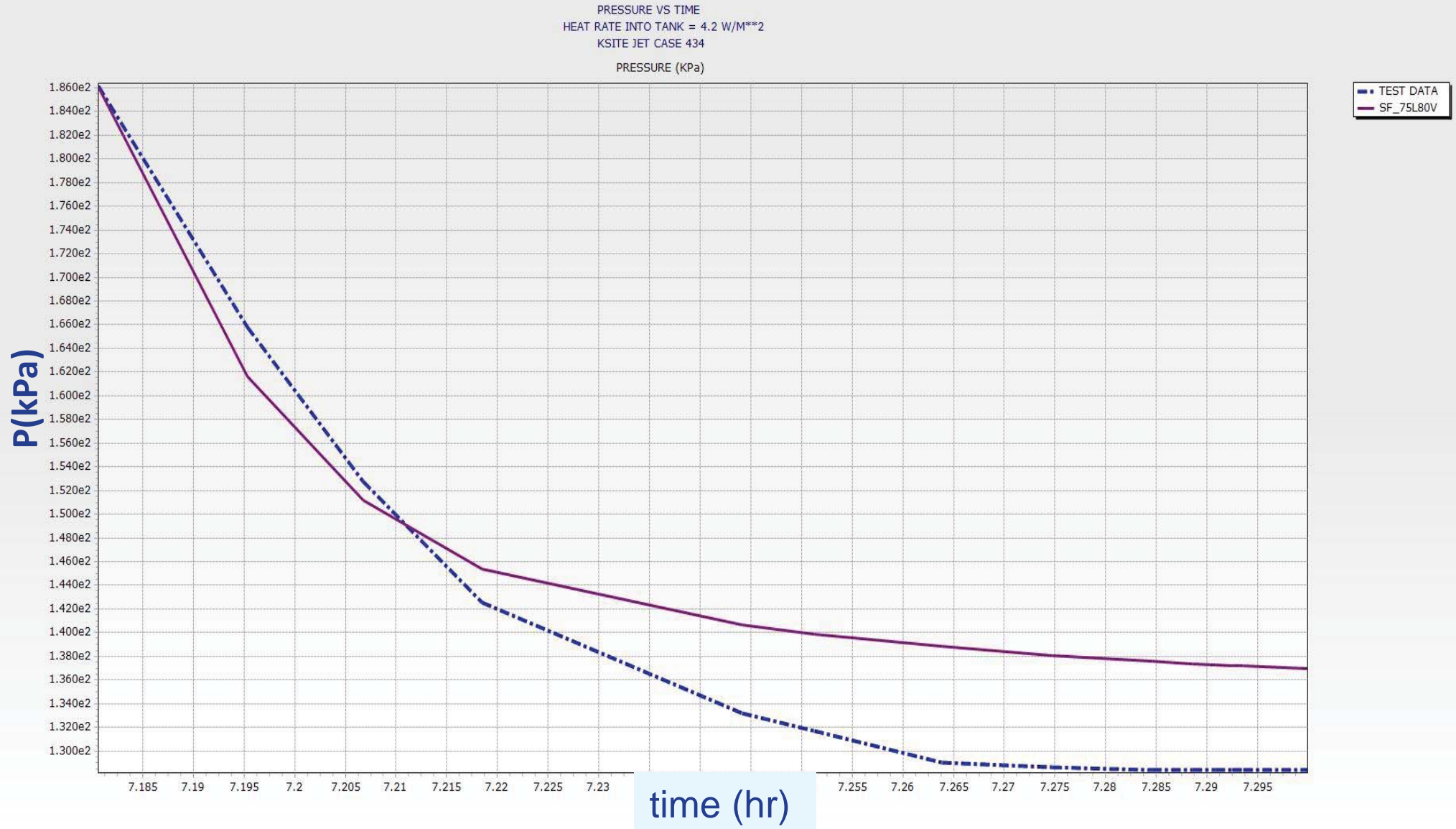



K-site LH2 1g Axial Jet: Experiment and SINDA/FLUINT

SINDA/FLUINT used 75 LIQUID LUMPS, 50 VAPOR LUMPS

Test Run 457 (49.1% liquid fill, 8.0132 GPM LH2 jet flow rate)

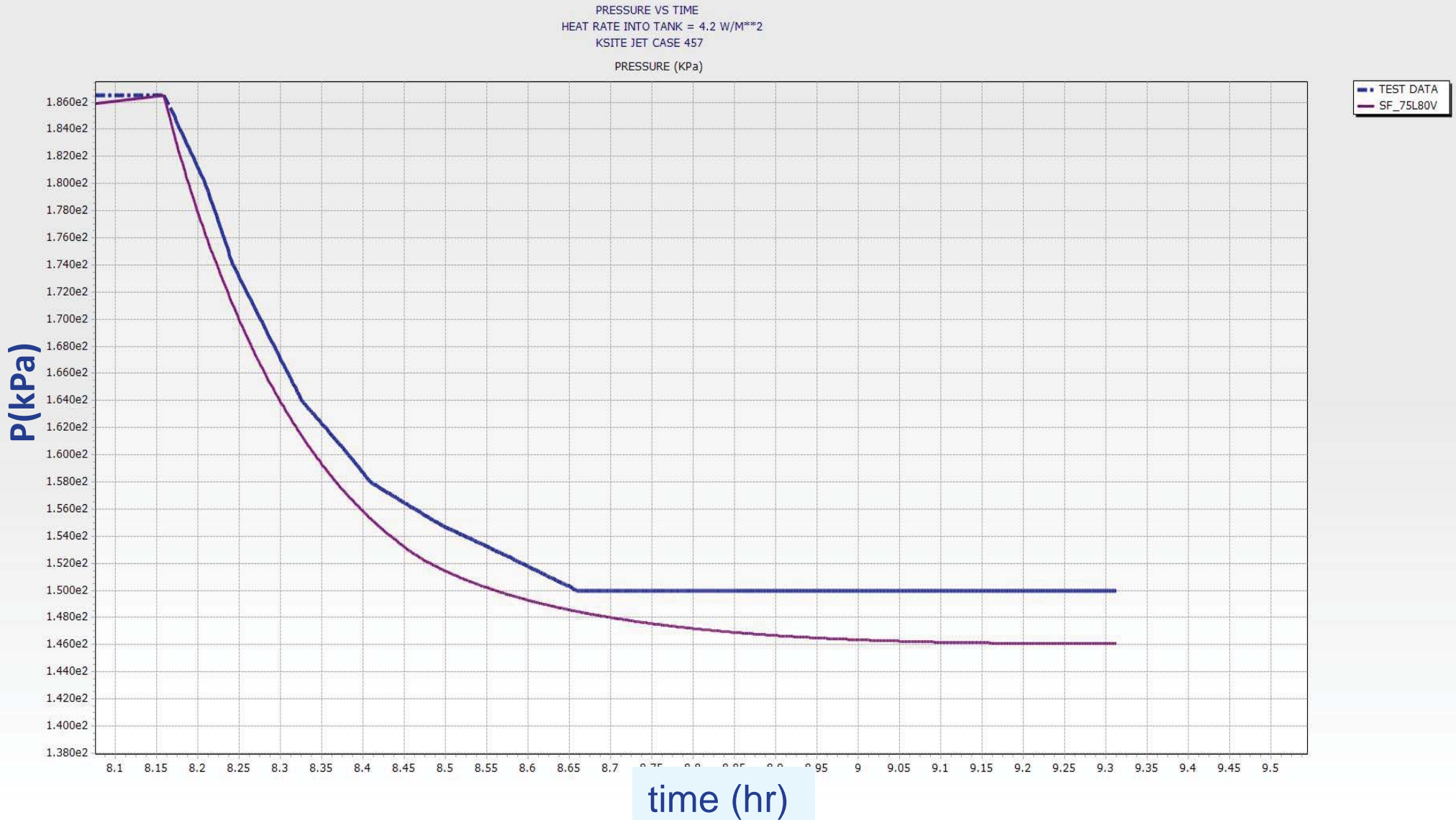



K-site LH2 1g Axial Jet: Experiment and SINDA/FLUINT

SINDA/FLUINT used 75 LIQUID LUMPS, 50 VAPOR LUMPS

Test Run 449 (49.1% liquid fill, 15.0138 GPM LH2 jet flow rate)

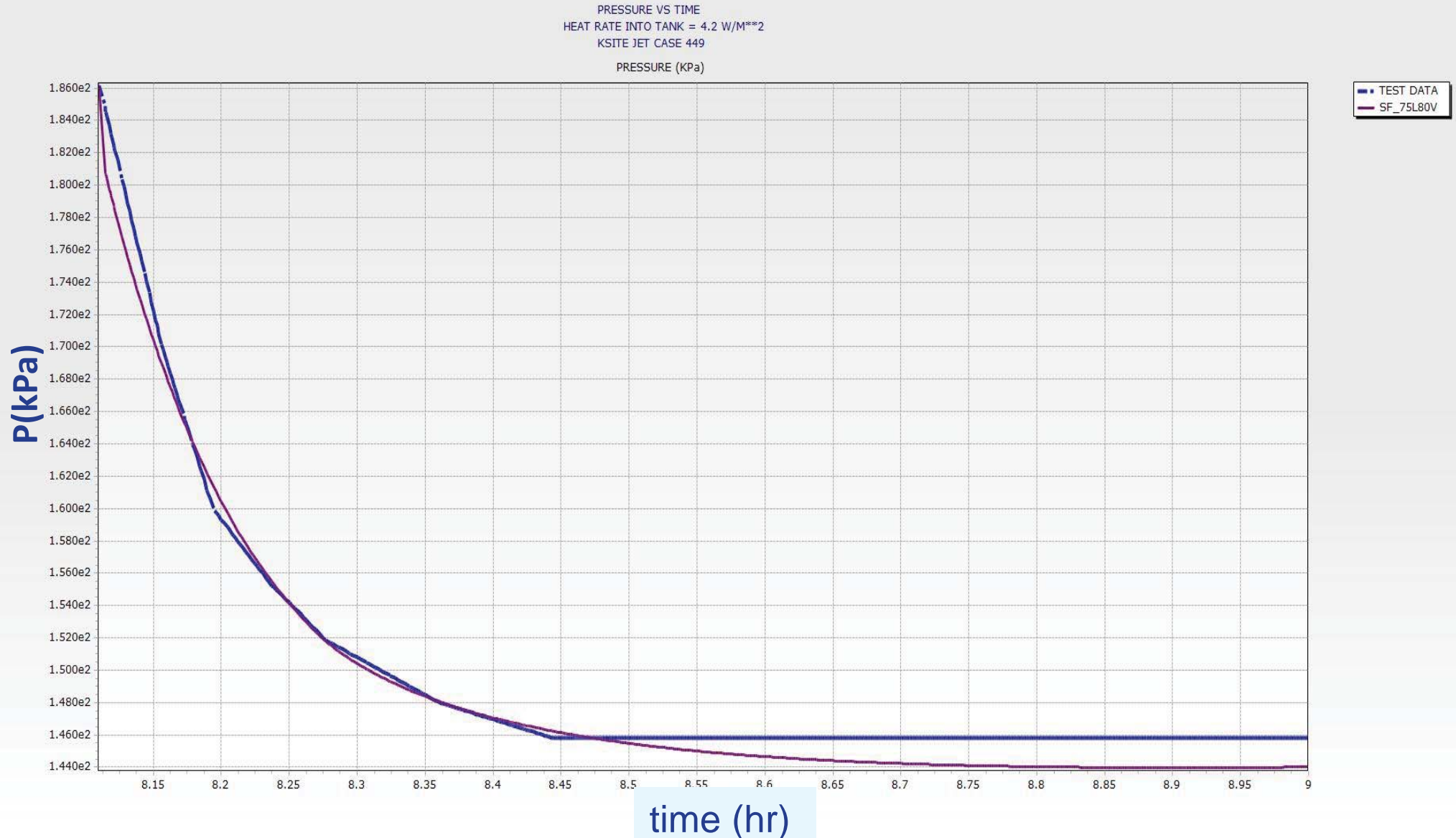



CFD Analysis



Verification and Validation Simulations

- Laminar Natural Convection in Closed Cavity (CFD benchmark)
(Hortmann, Peric & Scheuerer, Int. J. Numerical Methods in Fluids, v11, pp.189-207, 1990, $Ra=1e+6$)
- Laminar LH2 Self-pressurization in spherical tank (CFD benchmark)
(Panzarella & Kassemi, JFM, v484, pp.41-68, 2003, $Ra=3e+7$)
- Turbulent Natural Convection in Closed Cavity Experiment
(Tian & Karyiannis, IJHMT, v43, pp.849-884, 2000, $Ra = 2e+09$)
- Unconfined Turbulent Jet Experiment
(Wynanski & Fiedler, JFM, v38, pp577-612, 1969, $Re_j = 1e+5$)
- Water Slosh Experiment in Spherical Tank with Open Top
(Marsell et al., AIAA 2009-366)
- Zero-g Spherical Bubble with no heat and no mass transfer
(Analytical solution: Zero velocity. Shape remains spherical)
- Air Bubble Rising in a Water Column (CFD benchmark)
(Krishna & van Baten, Nature, v398, p.208, 1999)
- Micro-g Bubble in a Spherical LH2 Tank (CFD benchmark)
(Panzarella & Kassemi, JSR, v42, pp.299-308, 2005)



Validation Simulations

- K-Site LH2 Self-pressurization (1g)
- K-Site LH2 Axial Jet (1g)
- General Dynamics Small/Large Water Tank Jet Scaling Study (1g)
- MHTB LH2 Self-pressurization (1g)
- Sloshing with Heat Transfer (1g, silicone oil/air)

- MHTB LH2 Spray bar mixing (1g) – *on-going*
- TPCE axial jet mixing (micro-g, Freon 113) – *in progress*
- CNES LN2 sloshing with heat & mass transfer (1g, low-g) – *in progress*

- K-Site LH2 Tank Chillo-down (1g) – *attempted*



Flow-3D



Flow-3D (commercial CFD code from Flow Science)

Numerical Modeling

Volume of Fluid (VOF) method for fluid interfaces

Fractional areas/volumes (FAVOR) for geometry definition (no arbitrary body fitted grid)

sharp interface tracking model

Physical models

phase change (liquid-vapor)

surface tension

vapor and gas bubbles

spray

general moving objects (6 DOF)

porosity

Thermal Modeling

fluid to solid heat transfer

conduction (conjugate)

specified temperature

specified heat flux

Tank geometry modeled with FAVOR blockage algorithm.

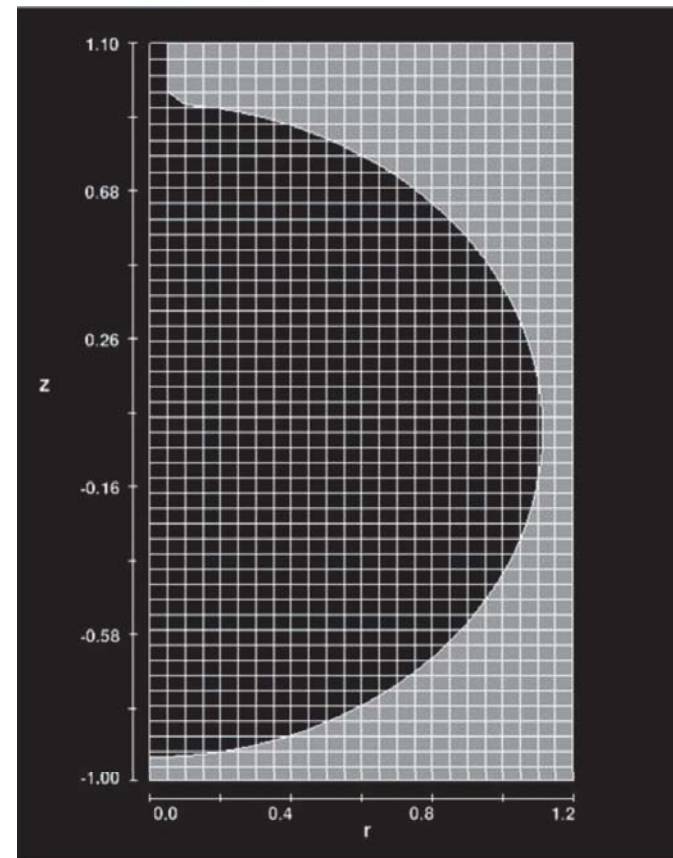



Typical Flow-3D Numerical Parameter Settings

Currently using Flow-3D v10.1 (Used v9.3, v10.0 on previous validation cases)

Mesh - Cartesian ~ 5000 to over 10 million active cells
 2D-axisymmetric, 3D sectors, full 3D
 Have tried multi-block without much success (spurious velocities at block boundaries)

Typical Initial Conditions velocity - 0
 pressure – uniform or hydrostatic
 temperature uniform or stratified
 turbulent kinetic energy – 0

Numerics - $\Delta t_{\text{initial}} - 1.e-9 \text{ s}$ $\Delta t_{\text{max}} - \sim 5e-5 \text{ to } 1e-3 \text{ sec}$ (adaptive: determined by stability)

pressure	- GMRES
momentum advection	- 2 nd order monotonicity preserving
heat transfer	- 2 nd order
density	- 2 nd order
viscous stress	- explicit
turbulence model	- laminar, k- ϵ , RNG
VOF advection	- Unsplit Lagrangian (Auto, and Split Lagrangian)



Comments on User Functions and Lagrangian Spray

- ❖ No User-Define-Functions (UDFs) have been used for Flow-3D customization for the cryogenic system simulations performed so far, although such customization is possible
- ❖ However, Lagrangian spray / Volume of Fluid (VOF) simulations for MHTB spray bar experiment did use a customized version (9.3 T) of Flow-3D (provided to NASA and Boeing for internal use under a subcontract to Flow Science, Inc.). That Lagrangian spray/VOF capability is now part of the standard Flow-3D release as of version 10.1 (and now includes turbulent dispersion of spray drops)

K-site 1g LH2 Self-Pressurization with Conjugate Heat Transfer

Description:

- flight weight tank; wall thickness = 2.21 to 3.94 mm
- 2.2m diameter tank ($D/t_{wall} = 1000$ to 560)
- 17.5 hrs self-pressurization, 3.5 W/m² into tank
- Want to DECREASE simulation time by thickening tank walls (to enable practical tank chilldown runs)

Flow-3D self-pressurization Simulations

- Tank wall not gridded
- Wall thickness increased 10x; matching Bo and Fo numbers (Cp & k scaling)
- Wall thickness increased by 10x; wall Cp scaling only

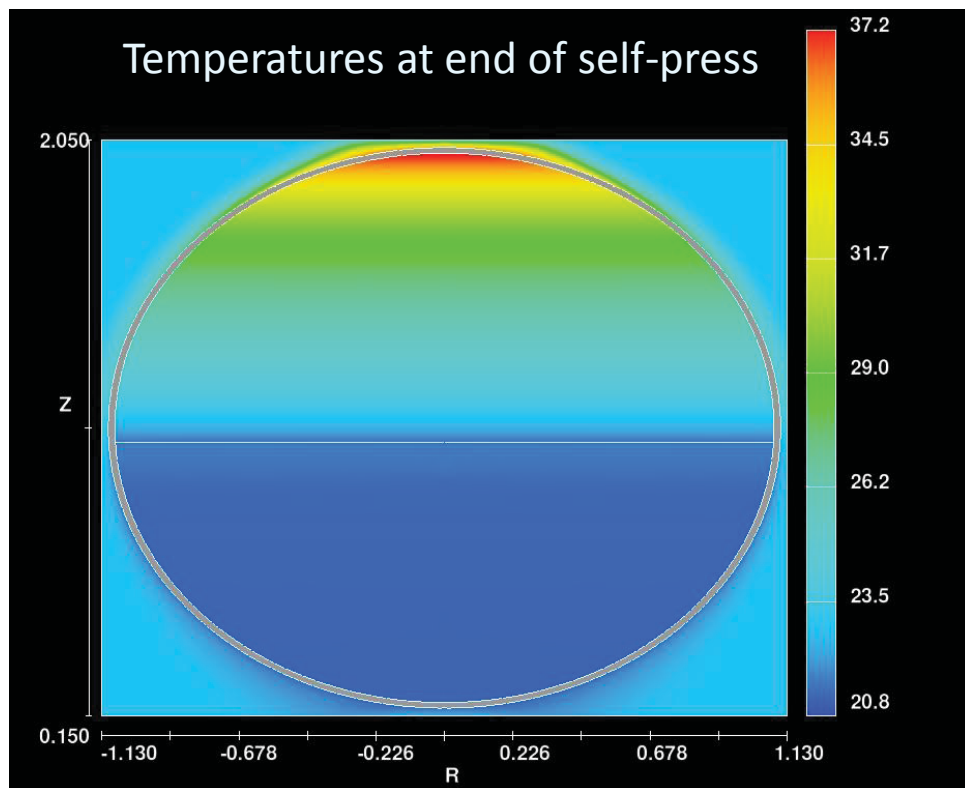

Thickened walls → $dt = 5e-4$ sec; 30 days to complete run
 No walls → $dt = 1.45e-2$ sec; 1.5 days to complete run

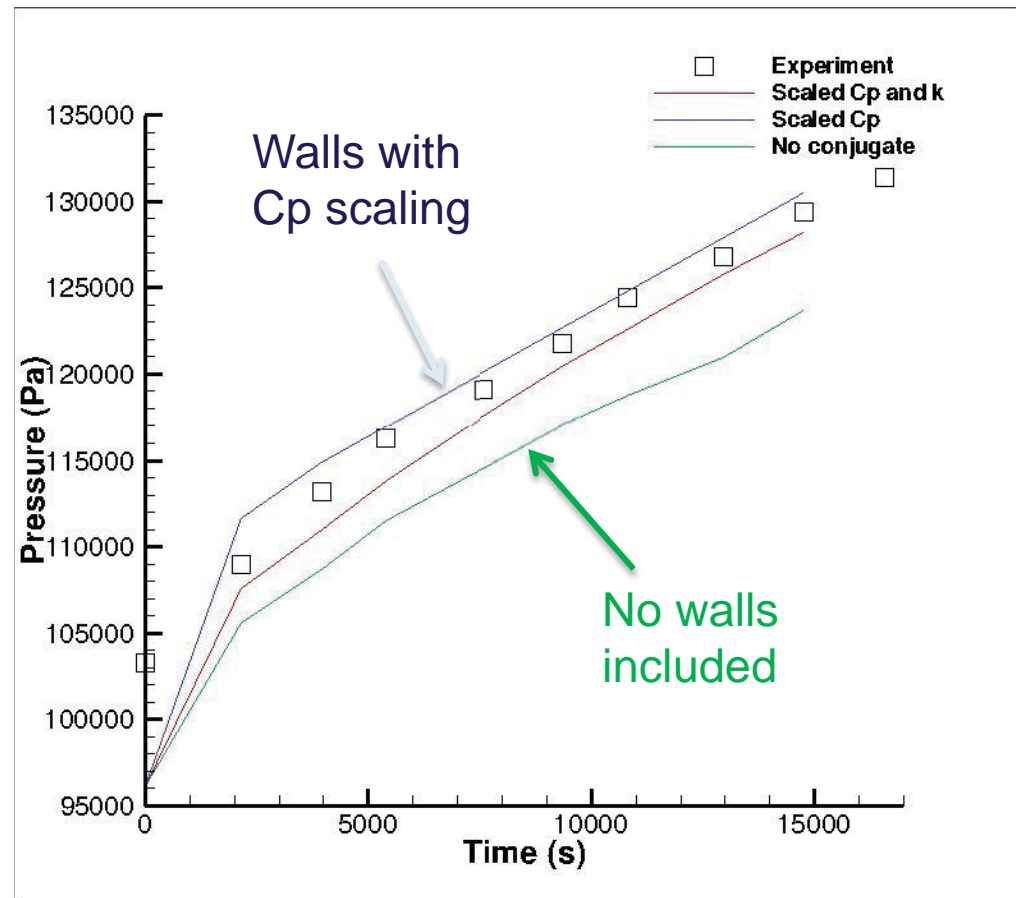

Experimental Setup for Slosh with Heat Transfer

Silicone Oil Lateral Sloshing Experiment

AIAA-2010-6979

“Heat Exchange and Pressure Drop Enhanced by Violent Sloshing”

T. Himeno, et al (University of Tokyo)

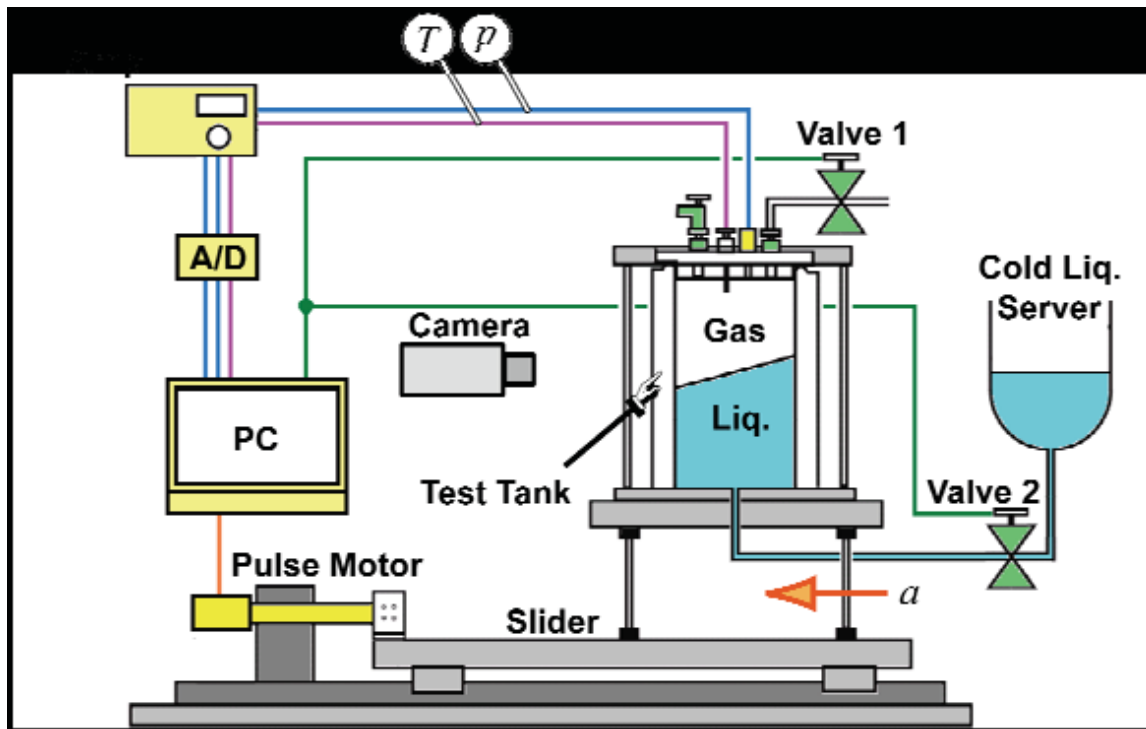

Schematic of experimental set up.

Transparent cylindrical tank (acrylic resin)

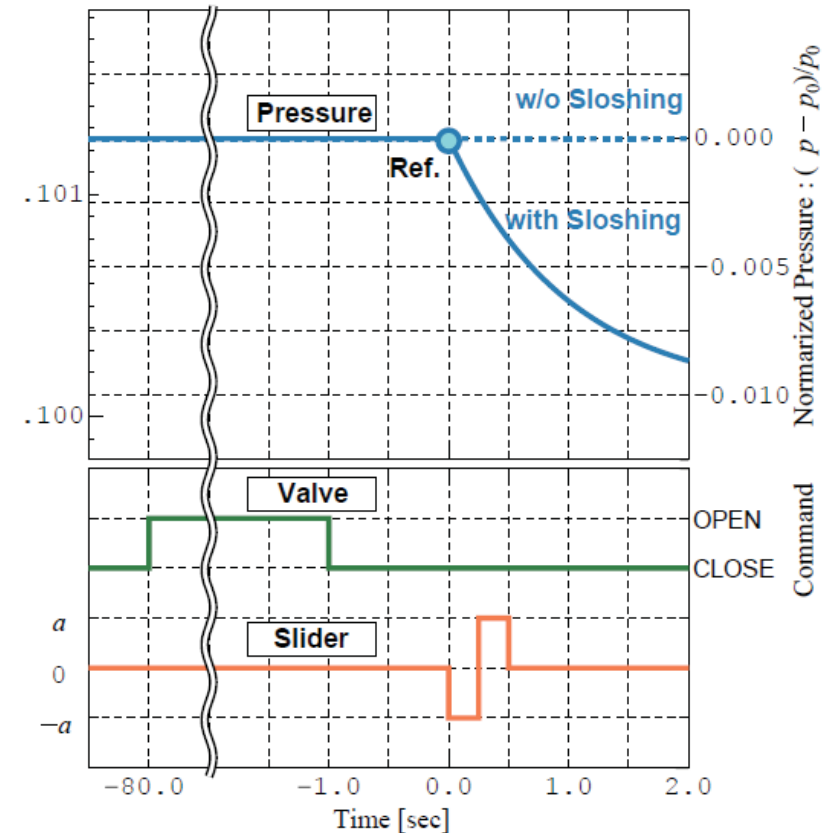

Sequence and expected pressure variation in the experiment



Initial Condition and Fluid Properties

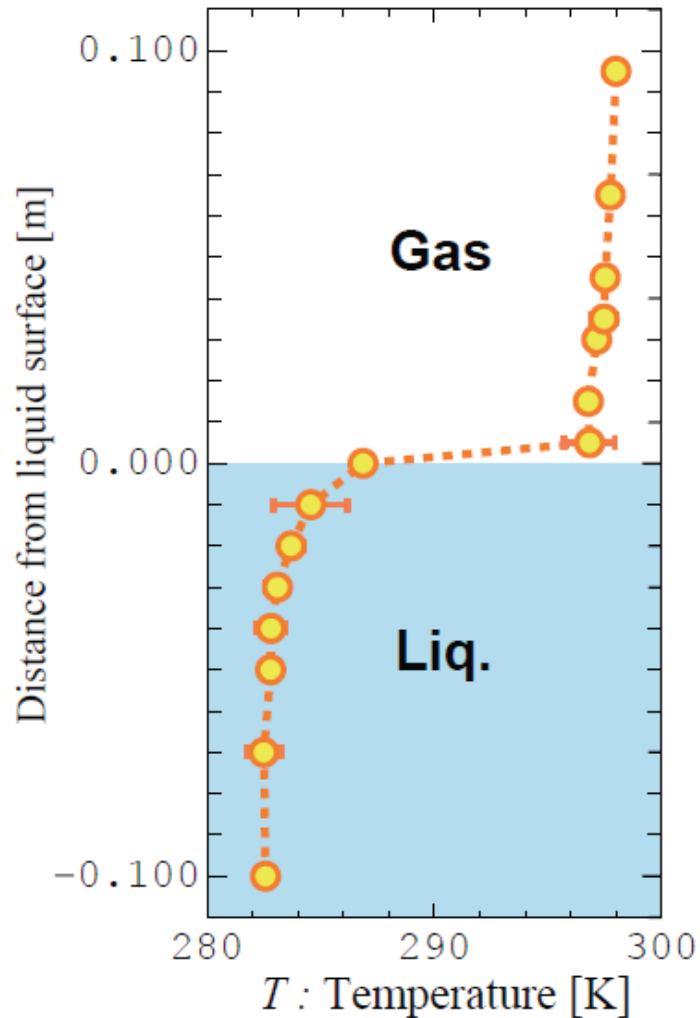

Ullage – **air** at 298K and .1013 Mpa

Liquid – chilled, non-volatile **silicone oil**
kinetic viscosity $1\text{e-}6\text{ m}^2/\text{s}$
density 818 kg/m^3
surface tension 16.9 mN/m
thermal conductivity 1 W/m K
specific heat $2\text{e-}3\text{ J/kg K}$

Tank inner diameter 0.110 m

Tank height 0.230 m

Full 3D grid: 375,636 active cells

Initial Temperature Distribution before sloshing

Comparison of Flow-3D and Experiment Video (0.5g Amplitude)



("surface" shows liquid colored by pressure contours)

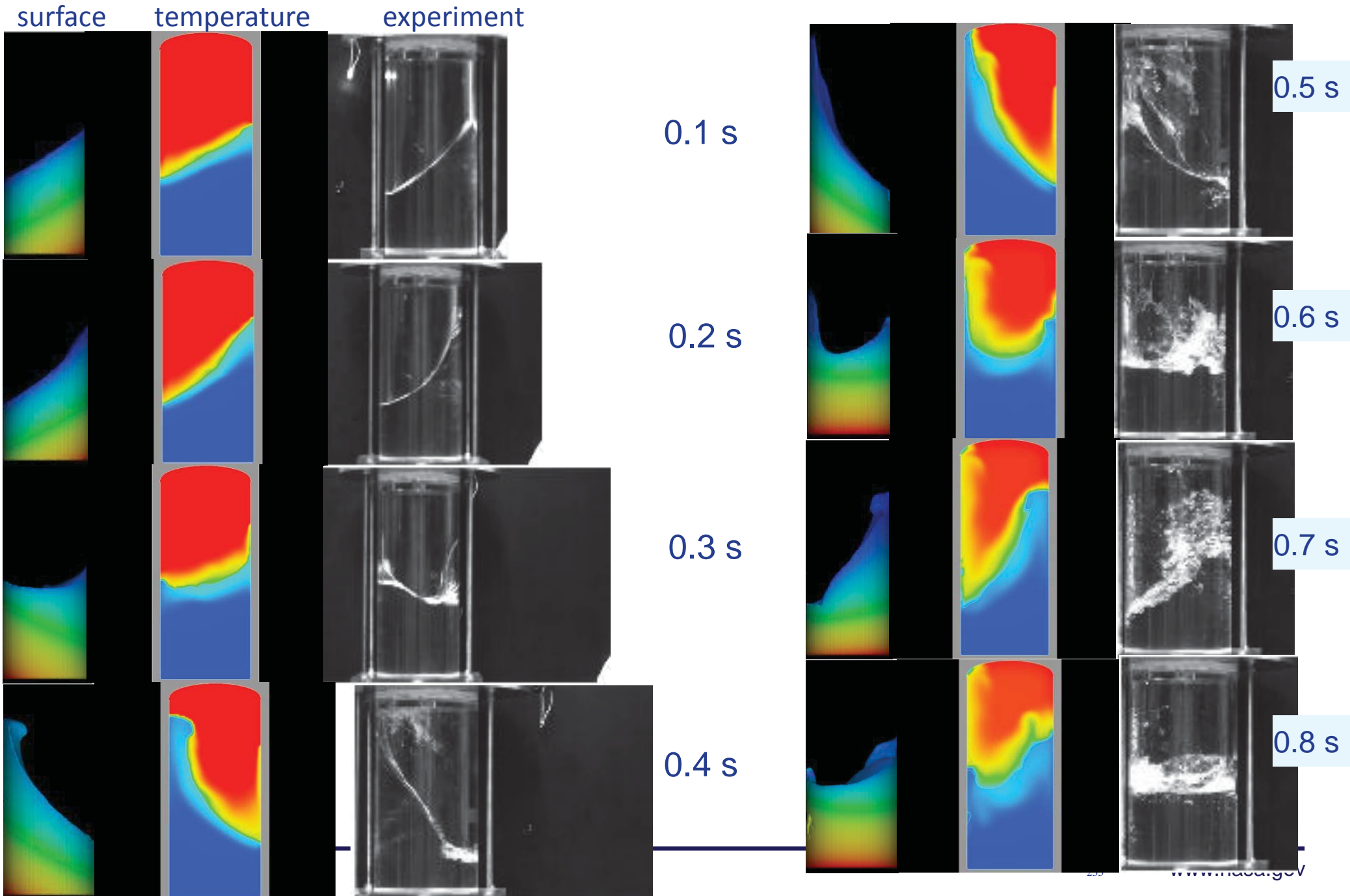

Comparison of Flow-3D and Experiment Video (0.5g Amplitude)



("surface" shows liquid colored by pressure contours)

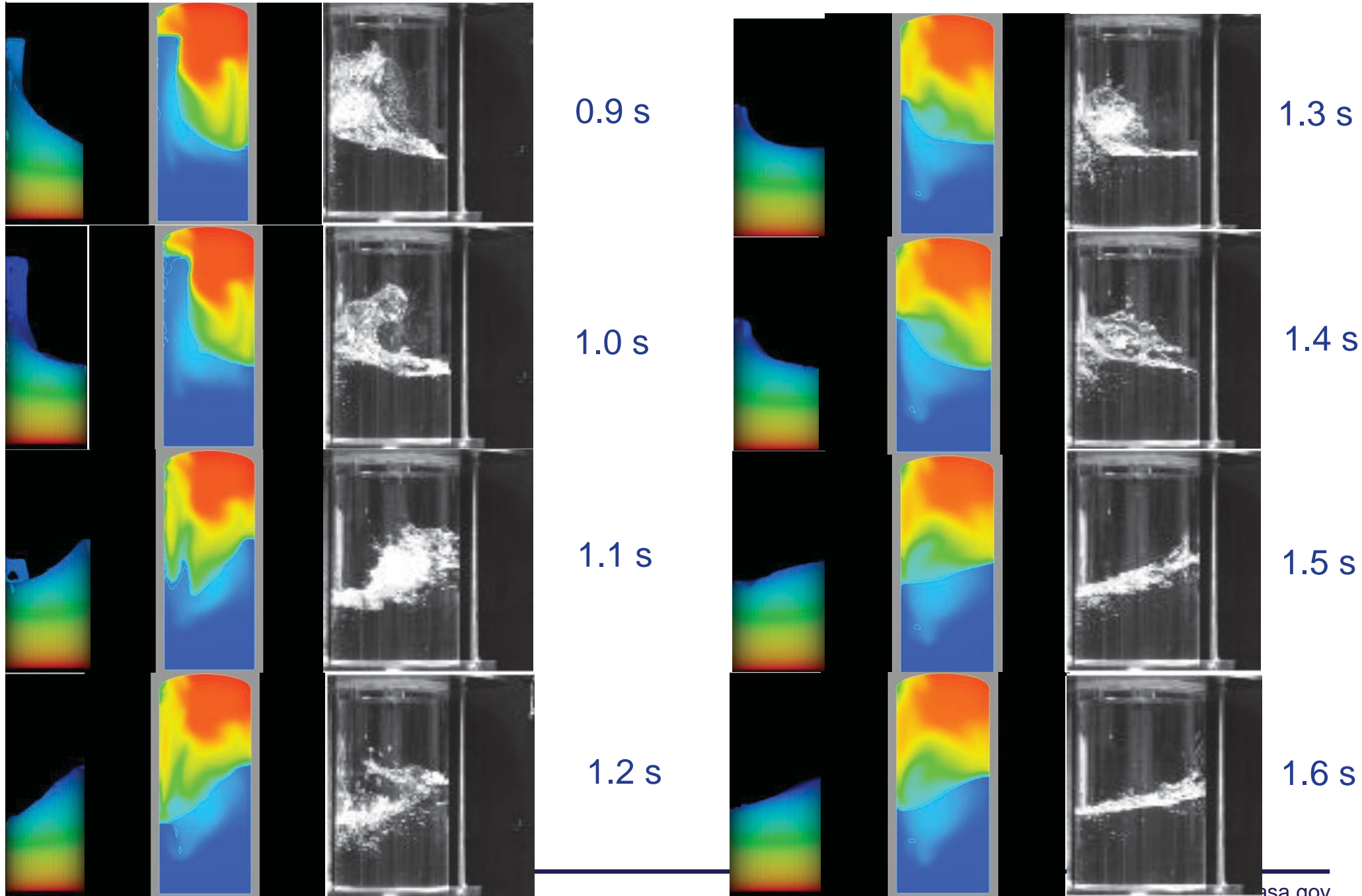

Comparison of Flow-3D and Experiment Video (0.5g Amplitude)



("surface" shows liquid colored by pressure contours)

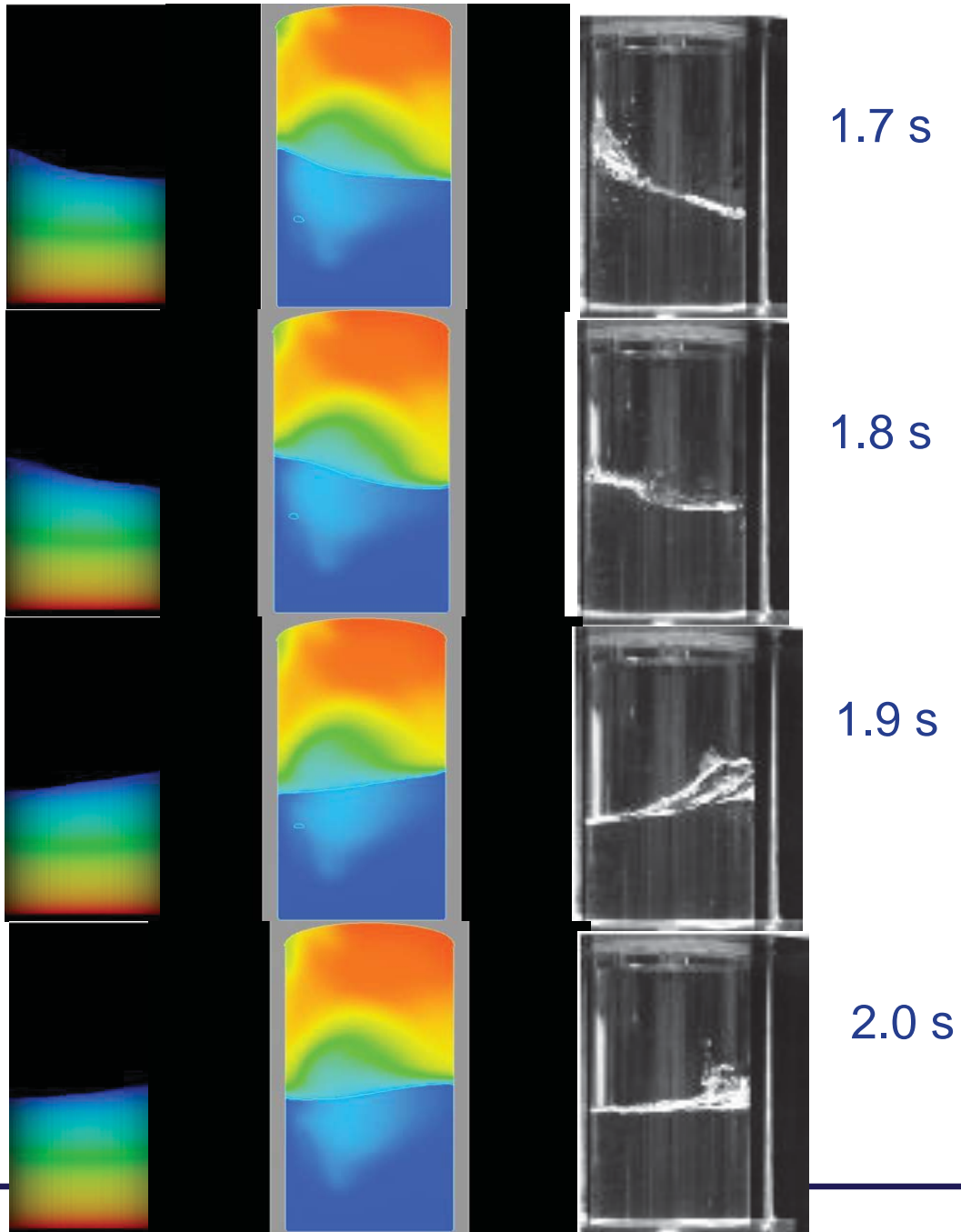

Comparison of Flow-3D and Experiment Pressure Reduction during Slosh (no mass transfer)

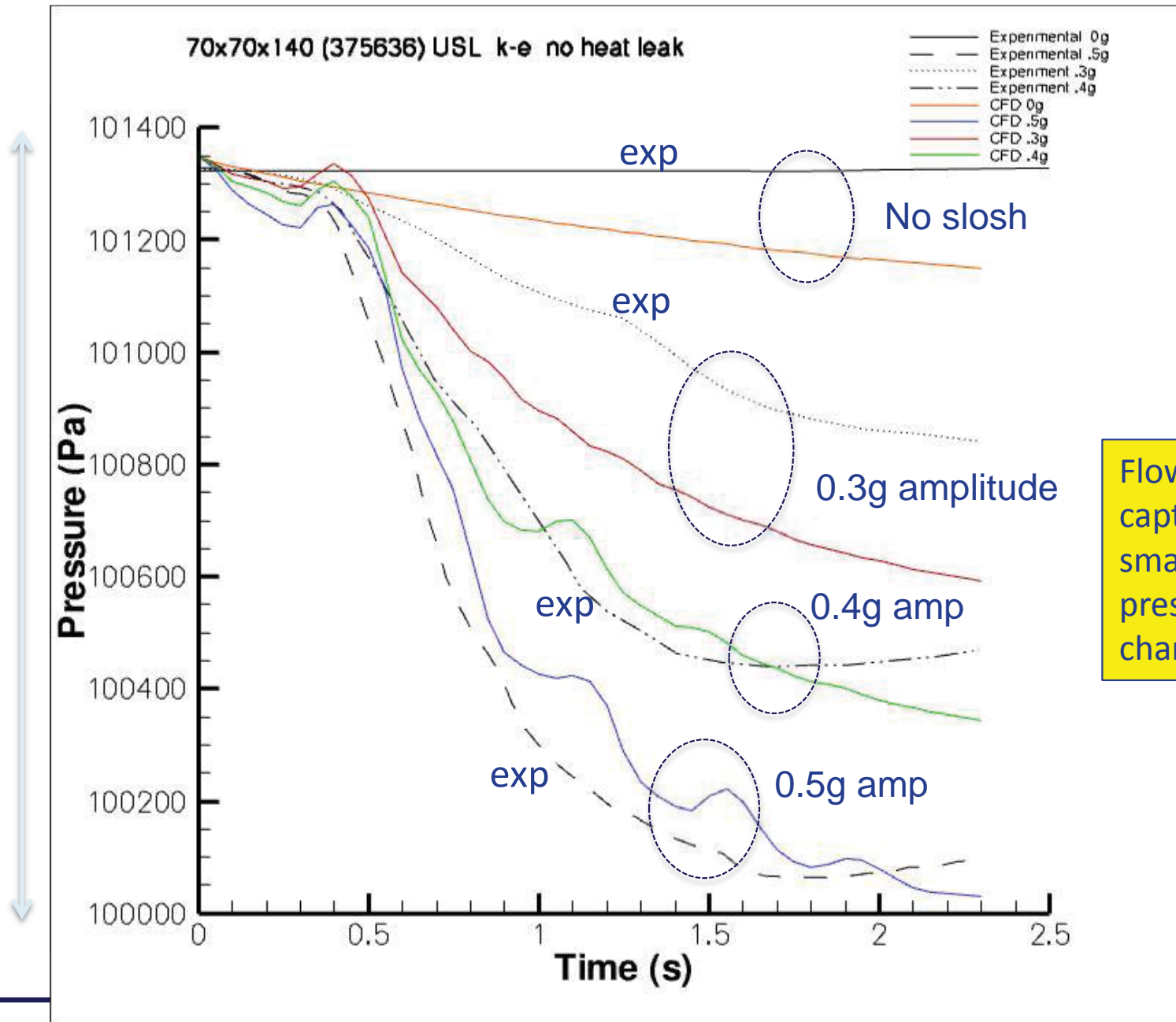

Flow-3D is capturing small pressure changes



Fluent



Typical Fluent Setup for Cryo Simulations

- Most simulations performed using ANSYS Fluent version 13 (have used 14 and 15)
- **Compressible** ideal gas
- **2D-axisymmetric and 3D sector** grids
- Customized **VOF** method of ANSYS Fluent compared with in-house developed **Sharp Interface** model
- Interfacial mass transfer: Schrage or Energy Jump Condition (Sharp Interface only)
- Conjugated equations for conduction in the tank wall
- Computational grid refined near the interface and boundary layer is resolved ($y^+ \sim 1$)
- **k- ω SST** turbulence model of Menter et. Al (Turbulent Damping = 10 to 100 at interface)
- Surface tension effects via Continuum Surface Force method of Brackbill et al.

- **Second Order Upwind** scheme was used for discretization of the Turbulence, Energy and Momentum equations (cell values)
- **PISO** scheme was used for the Pressure-Velocity coupling (cell values)
- Least Squares Cell Based scheme was used for the gradient calculations (face values)
- Body Force Weighted scheme was used for the Pressure interpolation (face values)
- Point Implicit (Gauss-Seidel) linear equation solver with Algebraic Multi-Grid (AMG) method was used for solving linearized systems of equations
- First order temporal discretization was used with the VOF model and Second order scheme was used with the Sharp Interface model



Diffuse Interface versus Sharp Interface

Diffuse Interface methods such as Volume of Fluid (VOF) will smear the interface over several spatial grid cells. Good method when large changes occur in interface shape and location.

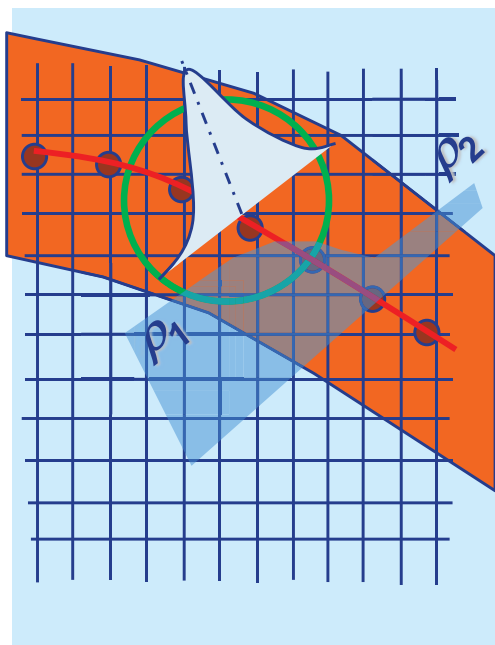

Diffuse Interface

Sharp Interface methods such as the approach NCSEER added to Fluent uses a zero thickness interface. Good method when interface shape and location change very little.

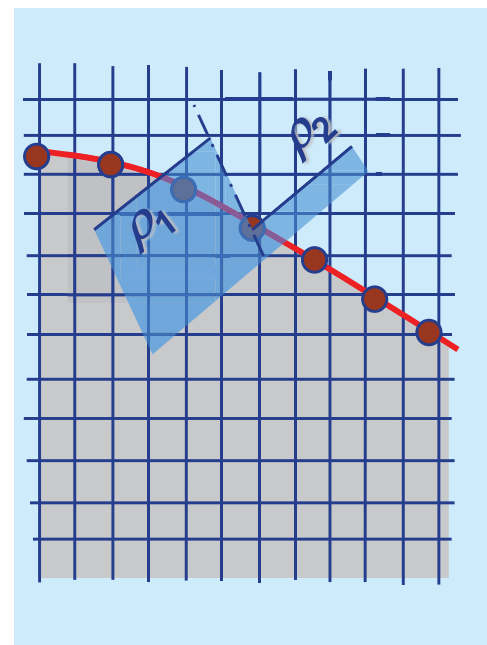

Sharp Interface



Volume of Fluid (VOF) mass transfer model:

Schrage's Relation:
$$|\dot{\mathbf{m}}| = \left(\frac{2\sigma}{2 - \sigma} \right) \left(\frac{M}{2\pi R} \right)^{1/2} \left(\frac{P_i}{T_i^{1/2}} - \frac{P_v}{T_v^{1/2}} \right), \left[\frac{kg}{m^2 \cdot sec} \right]$$

where σ – evaporation efficiency (0.01 to 0.001 typically used. **No experimental data for cryo**)
 M – molar mass of hydrogen (value of 2 was used)
 R – universal gas constant (8.314472 J/mol K)
 P_i and P_v – interfacial and vapor pressures, Pa
 T_i and T_v – interfacial and vapor temperatures, K (assumed that $T_i = T_v \cong T_{sat}$ at the interface)

Sharp Interface model:

Interfacial Energy Balance:
$$|\dot{\mathbf{m}}|L = \mathbf{q}_{il} - \mathbf{q}_{iv} \longrightarrow T_i$$

Continuity at the Interface:
$$v_{\tan g_v} = v_{\tan g_l}; \quad \tau_{\tan g_l} = \tau_{\tan g_v};$$

Turbulence modeling:

k- ω SST model with interfacial B.C.:

Wall

$$k = 0; \quad \omega = \frac{\rho(u^*)^2 6}{\mu \beta_i (y^+)^2}$$

Turbulence Damping

$$S_i = \mathbf{A}_i \Delta n \beta \rho_i \left(\frac{B \delta \mu_i}{\beta \rho_i \Delta n^2} \right)^2$$

Continuity

$$\nabla k_l = \nabla k_v; \quad k_l = k_v \Big|_{\text{interface}}$$

$$\nabla \omega_l = \nabla \omega_v; \quad \omega_l = \omega_v \Big|_{\text{interface}}$$



Fluent customization through the UDFs

VOF (DEFINE_MASS_TRANSFER)

- ❖ Calculate mass transfer using Schrage relation and supply it to Fluent for phase interaction at the interface

Sharp Interface (DEFINE_ADJUST, DEFINE_PROFILE, DEFINE_SOURCE)

- ❖ Calculate energy balance at the interface and supply to Fluent resulting interface temperature. Perform shear stress and velocity continuity at the interface. Define mass transfer through source terms on the vapor side. Use Schrage or Jump Condition.

Lagrangian spray (DEFINE_DPM_SCALAR_UPDATE, DEFINE_SOURCE)

- ❖ Perform particle tracking in the vapor, remove particles from the vapor domain when they reach the interface and add their contributions to the liquid through source terms. Define sources for the spray bar liquid jets.
- ❖ Calculate heat and mass transfer between liquid spray drops and surrounding ullage gas
- ❖ *NOTE: VOF + Lagrangian spray requires you “tell” Fluent drop are “inert” and allow heat and mass transfer btw drops/ullage via UDF*

K-Site 1g LH2 Self-Pressurization and LH2 Axial Jet Mixing

Self-Pressurization

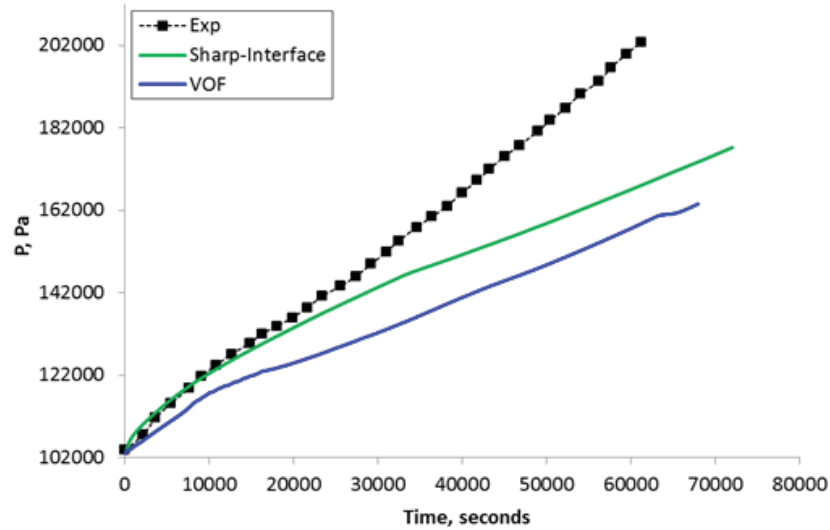

Jet Mixing

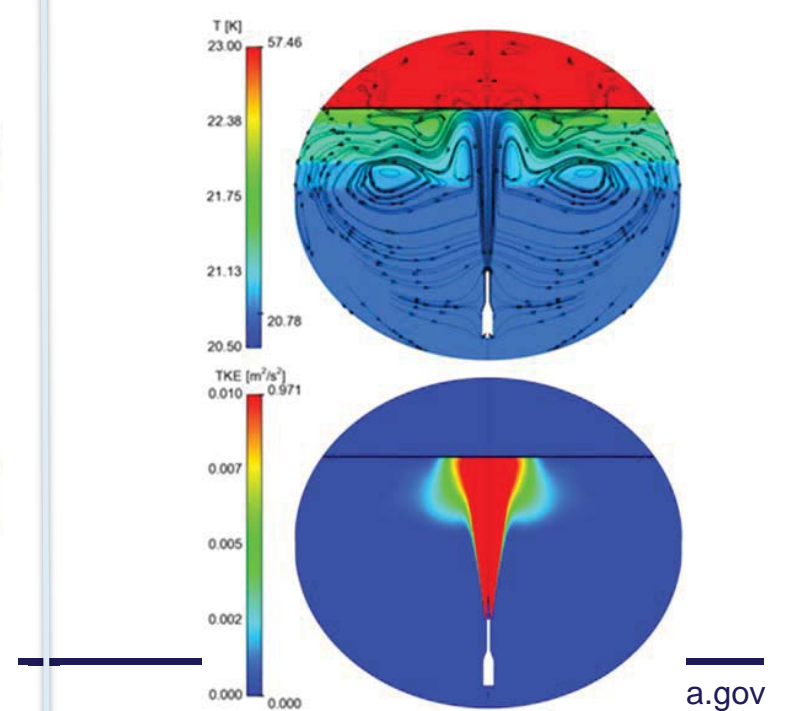
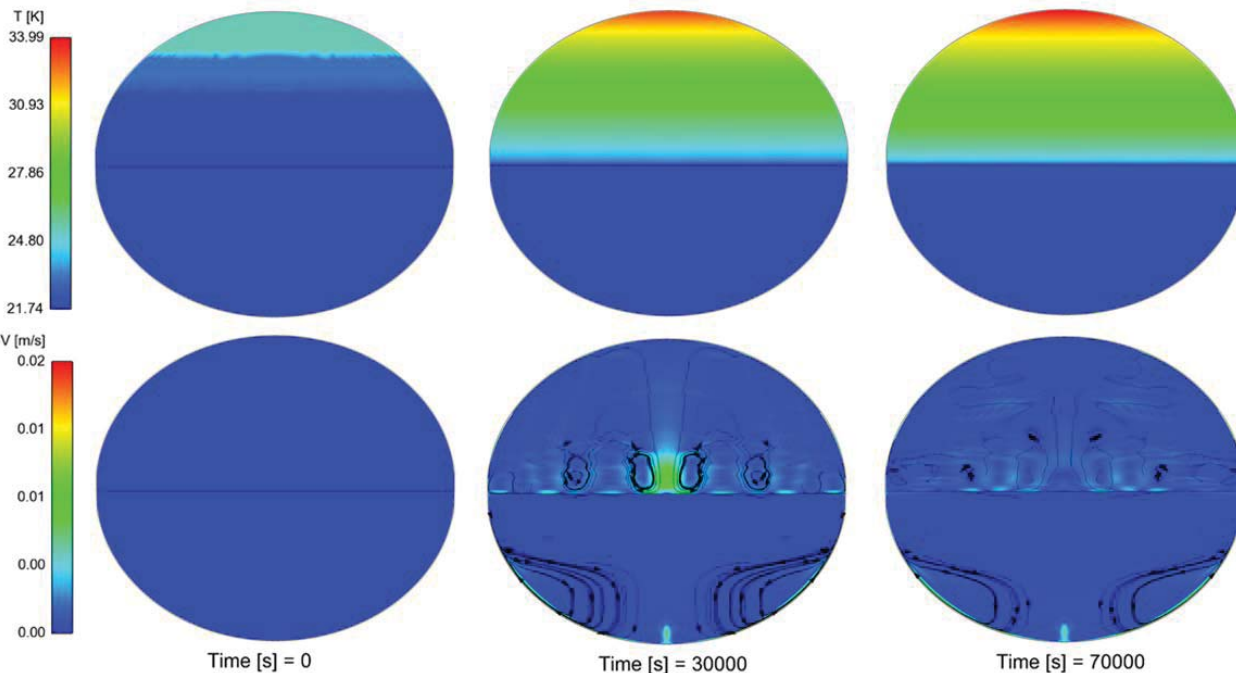
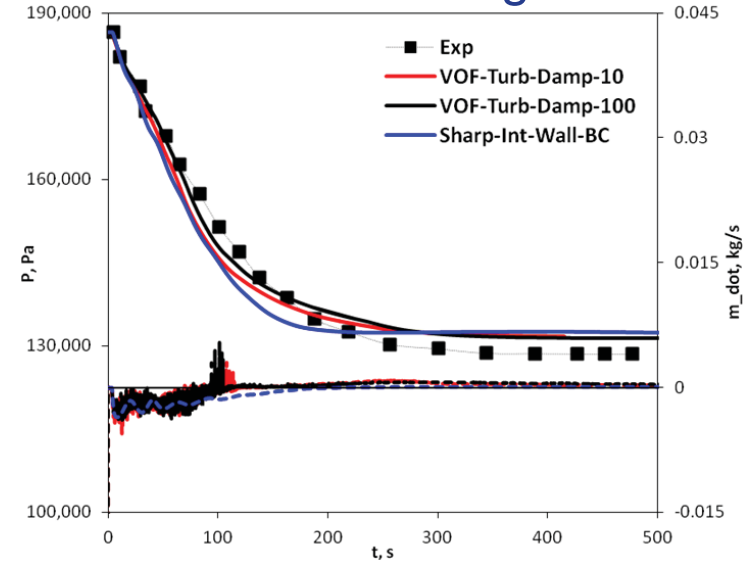

MHTB 1g LH2 Self-pressurization

USER Defined Functions (UDFs) developed:

- UDF for mass transfer (evaporation or condensation of drops in ullage) between drops and ullage
- UDF for removing drop from the Lagrangian solver and conserving mass, momentum and energy for those drops crossing from ullage into bulk liquid
- UDF for mass transfer at liquid/ullage interface
- UDF for point sources for “tiny jets” in the liquid

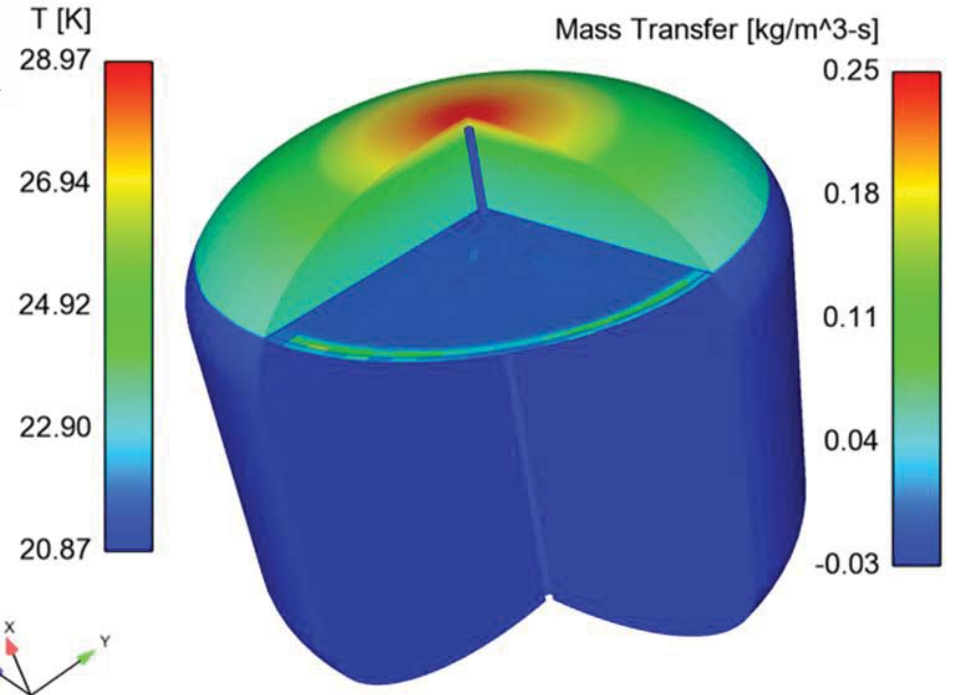
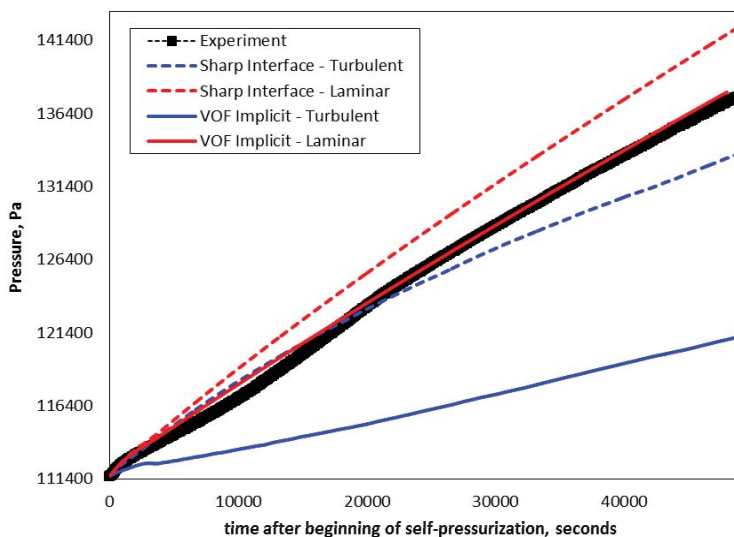
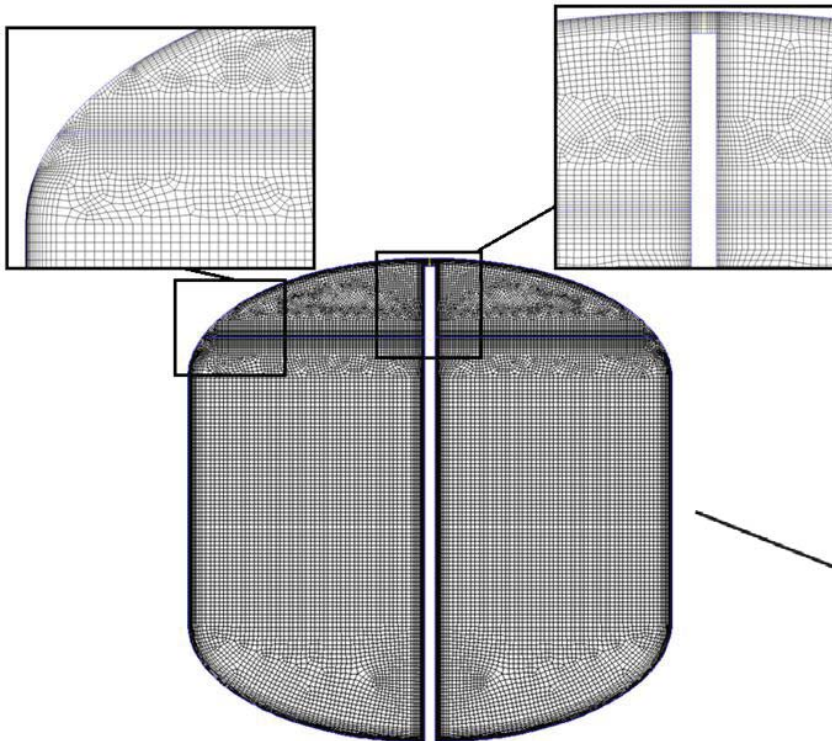



Recommendations for Analysis Tool Usage

- For **settled** conditions with **no significant distortion of liquid/ullage interface**, multinode codes are sufficient. Multinode nodes should be used in the ullage and dry-wall regions if possible (i.e., supported by the multinode code). If CFD is used, a Sharp Interface (fixed interface shape/position) model may provide reduced simulations times and better accuracy (compared to VOF).
- For **settled** conditions **with significant distortion of liquid/ullage interface**, multinode may be used if correlations exist similar to your flow conditions (such as axial jet mixing). Otherwise, a limited number of CFD simulations should be conducted to provide data for tuning your multinode correlations for heat/mass transfer at interface.
- For **unsettled conditions and/or significant distortion of liquid/ullage interface**, CFD is currently the only analysis tool available to predict the fluid dynamics and thermodynamics occurring inside the propellant tank.



Conclusions

- Cryogenics is all about thermodynamics and heat transfer and requires analysis methods and tools to evaluate:
 - Conduction
 - Convection
 - Radiation
 - Two-Phase Flow
 - Fluid State Conditions in Cryogenic Storage & Transfer Systems
- Cryogenics requires a multi-disciplinary approach and engineers must consider all operational phases including requirements, design, build-up, check-out and testing.
- Safety is something that the engineering team must consider during all project phases. Safety committee members should be invited to all design reviews.
- Multiple Codes and standards are available to aid the designers and users of cryogenic systems



Conclusions (cont'd)

- Instrumentation and controls provide the data that the test has been designed for. When in doubt, more measurements are better than less. Incorporate redundant instrumentation for all critical measurements
- There are hazards associated with handling cryogenic fluids un-like most normal fluids. Always be AWARE of
 - Trapped Liquids and Over-pressurization
 - Asphyxiation
 - Oxygen Enrichment
 - Frost Formation on Insulated Surfaces
 - Vents & Cold Surfaces to avoid Cryogenic Burns
- Pressure systems need to undergo a PV/PVS audit and certification process, prior to testing with cryogenes. Allocate schedule provisions for that work in your test planning



Conclusions (cont'd)

- There are many different functions that the hardware will have to do.
 - In general you will “optimize” it for one of the functions
 - The other functions may be required, but will be secondary
 - A proper definition of the objectives of the test or operational requirements as well as uncertainty and sensitivity analysis should separate the important functions from the secondary functions
- Different materials react differently when experiencing cryogenic temperatures
 - Due to phase changes in the metal, there are even differences using the same material in different temperature ranges



If we knew what we were doing it wouldn't be research

A. Einstein

“Remember in cryogenics, heat is the enemy”.



T. Tomsik