

NASA/TM—2009-215386

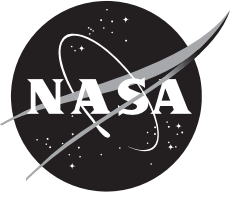

Influence of Combined Whole-Body Vibration Plus G-Loading on Visual Performance

Bernard D. Adelstein
Brent R. Beutter
Mary K. Kaiser
Robert S. McCann
Leland S. Stone
NASA Ames Research Center, Moffett Field, California

Mark R. Anderson
Fritz Renema
PerotSystems
NASA Ames Research Center, Moffett Field, California

William H. Paloski
NASA Johnson Space Center

May 2009

NASA STI Program...in Profile

Since its founding, NASA has been dedicated to the advancement of aeronautics and space science. The NASA scientific and technical information (STI) program plays a key part in helping NASA maintain this important role.

The NASA STI program operates under the auspices of the Agency Chief Information Officer. It collects, organizes, provides for archiving, and disseminates NASA's STI. The NASA STI program provides access to the NASA Aeronautics and Space Database and its public interface, the NASA Technical Report Server, thus providing one of the largest collections of aeronautical and space science STI in the world. Results are published in both non-NASA channels and by NASA in the NASA STI Report Series, which includes the following report types:

- **TECHNICAL PUBLICATION.** Reports of completed research or a major significant phase of research that present the results of NASA Programs and include extensive data or theoretical analysis. Includes compilations of significant scientific and technical data and information deemed to be of continuing reference value. NASA counterpart of peer-reviewed formal professional papers but has less stringent limitations on manuscript length and extent of graphic presentations.
- **TECHNICAL MEMORANDUM.** Scientific and technical findings that are preliminary or of specialized interest, e.g., quick release reports, working papers, and bibliographies that contain minimal annotation. Does not contain extensive analysis.
- **CONTRACTOR REPORT.** Scientific and technical findings by NASA-sponsored contractors and grantees.

- **CONFERENCE PUBLICATION.** Collected papers from scientific and technical conferences, symposia, seminars, or other meetings sponsored or co-sponsored by NASA.
- **SPECIAL PUBLICATION.** Scientific, technical, or historical information from NASA programs, projects, and missions, often concerned with subjects having substantial public interest.
- **TECHNICAL TRANSLATION.** English-language translations of foreign scientific and technical material pertinent to NASA's mission.

Specialized services also include creating custom thesauri, building customized databases, and organizing and publishing research results.

For more information about the NASA STI program, see the following:

- Access the NASA STI program home page at <http://www.sti.nasa.gov>
- E-mail your question via the Internet to help@sti.nasa.gov
- Fax your question to the NASA STI Help Desk at (301) 621-0134
- Phone the NASA STI Help Desk at (301) 621-0390
- Write to:
NASA STI Help Desk
NASA Center for AeroSpace Information
7121 Standard Drive
Hanover, MD 21076-1320

NASA/TM—2009-215386

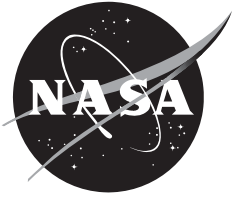

Influence of Combined Whole-Body Vibration Plus G-Loading on Visual Performance

Bernard D. Adelstein
Brent R. Beutter
Mary K. Kaiser
Robert S. McCann
Leland S. Stone
NASA Ames Research Center, Moffett Field, California

Mark R. Anderson
Fritz Renema
PerotSystems
NASA Ames Research Center, Moffett Field, California

William H. Paloski
NASA Johnson Space Center

National Aeronautics and
Space Administration

Ames Research Center
Moffett Field, California 94037

May 2009

ACKNOWLEDGMENTS

We extend our sincerest thanks to Dr. Ralph Pelligra, M.D., the Chief Medical Officer and Chair of the Institutional Review Board at NASA Ames Research Center. Dr. Pelligra's knowledge, expertise, and informed judgment were instrumental in designing a safe set of experimental procedures for all participants and, as medical monitor, in assuring the safety of the general-population participants during the course of these experiments. We would also like to thank Drs. Jeffrey Jones, Richard Scheuring, and Jonathan Clark, who provided medical monitoring during the Crew Office portion of the study. In addition, we express our appreciation to Tina Holden who helped prepare and then shepherd the Crew Office version of the protocol through the approval process of JSC's Committee for the Protection of Human Subjects (CPHS).

We gratefully acknowledge the design and engineering analysis expertise provided by Omar Talavera and Mike Ospring, and the brilliant technical support and camaraderie provided by the 20-G Centrifuge Facility staff (Cecilia Wigley, Nicki Rayl, Tony Purcell, Joseph Dwyer, Rick Ryzinga, Paul Brown, Tom Luzod, Russ Westbrook, Robert Phillips, Marianne Steele, and Valerie Post). We likewise thank our summer interns, Giovanna Flores and Diana Munoz-Villanueva, for their energizing enthusiasm and remarkable competence.

Finally, we thank our programmatic managers (Barbara Woolford, Jan Connolly, Dane Russo and Dennis Grounds at the Human Research Program and Cynthia Null at the NESC) for their advocacy and support of this study. And last but far from least, we thank our wonderful participants, both from the Ames Research Center community and the Crew Office at JSC; without them, nothing would be significant.

The use of trademarks or names of manufacturers in the report is for accurate reporting and does not constitute an official endorsement, either expressed or implied, of such products or manufacturers by the National Aeronautics and Space Administration.

Available from:

NASA Center for Aerospace Information
7121 Standard Drive
Hanover, MD 21076-1320
(301) 621-0390

NASA Center for Aerospace Information
7121 Standard Drive
Hanover, MD 21076-1320
(301) 621-0390

Contents

List of Figures	iv
List of Tables	iv
List of Acronyms and Abbreviations	iv
Executive Summary	1
1.0 Introduction	2
2.0 Problem Statement	3
2.1 Gx-Loading Impacts on Human Visuomotor Performance	4
2.2 Vibration Impacts on Human Visuomotor Performance	6
2.2.1 Display Vibration	6
2.2.2 Observer Vibration	7
2.3 Prior Study Using Vibration-Only Conditions	7
2.4 Combined Gx-Loading and Vibration	8
2.5 Targeted Trade Space	9
2.5.1 The Induced Environments	9
2.5.2 The Task	9
2.5.3 The Display/Interface Arrangement	10
2.6 Summary	10
3.0 Facilities	11
3.1 Fixed-Base Vibration Platform/Chair	11
3.2 Fixed-Base Display and Response Device	12
3.3 20-G Centrifuge Facility	13
3.4 Centrifuge Vibration Platform/Chair	13
3.5 Centrifuge Display and Response Device	15
4.0 Experiment 1A: General Population	15
4.1 Method	16
4.1.1 Participants	16
4.1.2 Stimuli	16
4.1.3 Procedure	18
4.2 Familiarization and Training Session on the Fixed-Base Platform	18
4.3 Familiarization Session in the 20-G Centrifuge	20
4.4 Reading-Task Test Sessions in the 20-G Centrifuge	22
4.5 Results	24
4.5.1 Objective Performance Data: Effect of Vibration Level and Font Size	24
4.5.2 Objective Performance Data: Effect of Target Location	28
4.5.3 Subjective Rating Data: Effect of Vibration Level and Font Size	30
4.5.4 Relationship between Object Performance and Subjective Rating Data	31
5.0 Experiment 1B: Crew Office Population	32
5.1 Method	32
5.1.1 Participants	32
5.1.2 Stimuli and Procedures	32
5.2 Results	33
5.2.1 Objective Performance Data: Effect of Vibration Level and Font Size	33
5.2.2 Subjective Rating Data: Effect of Vibration Level and Font Size	36
6.0 Conclusions	39
7.0 References	41

List of Figures

Figure 1. Vibration levels and human health and performance impacts.....	3
Figure 2. Mean SEM across participant for ER and RT effects due to Gx vibration	8
Figure 3. Human performance limits from Vvykukal & Dolkas comparisons.....	9
Figure 4. Ames Research Center's Fixed-Base Vibration Platform	12
Figure 5. Ames Research Center's 20-G Centrifuge Facility	13
Figure 6. Vibration platform and chair in the ARC 20-G Centrifuge cab	14
Figure 7. Reading-task display	17
Figure 8. Profile of G-only familiarization run.....	21
Figure 9. Profile of G-load plus vibration familiarization run.....	22
Figure 10. Profile of two blocks of trials in a number-reading test session.....	23
Figure 11. Median response times for vibration level and font size at constant 3.8 Gx bias	24
Figure 12. Median error rates for vibration level and font size at fixed 3.8 Gx bias.....	25
Figure 13. Mean response times during and immediately after vibration	26
Figure 14. Mean error rates during and immediately after vibration.....	27
Figure 15. Folding technique used to form column and row groupings	28
Figure 16. Effect of target location on response time.....	29
Figure 17. Effect of target location on error rate	30
Figure 18. Median of the Likert rankings as a function of vibration level	31
Figure 19. Mean response times of crew office participants during and after vibration	34
Figure 20. Mean error rates of crew office participants during and after vibration.....	34
Figure 21. Mean response times of general and crew office participants during vibration.....	35
Figure 22. Mean error rates of general and crew office participants during vibration	36
Figure 23. Crew office participants' median Likert rankings for 10pt number-reading task	37
Figure 24. Crew office participants' median Likert rankings for 14pt number-reading task.....	38

List of Tables

Table 1. Post-Block Questions.....	19
Table 2. Count and Proportion (%) of Significant Correlations	32

List of Acronyms

ANOVA ...Analysis of variance	JSCJohnson Space Center
ARCAmes Research Center	LCD.....liquid crystal display
CxConstellation	NASA.....National Aeronautics and Space Administration
CxP.....Constellation Program	ptpoint
ERError Rates	RGBred green blue
ESMDExploration Systems Mission Directorate	RPMrevolutions per minute
Gx.....Gravitational vector	RTresponse times
HORBHuman Occupancy Review Board	SEMStandard Error of the Means
HSIRHuman Systems Integration Requirements	SRRSystems Requirements Review
HzHertz	TOthrust oscillation
ISISIntelligent Spacecraft Interface Systems	VORvestibular ocular reflex

Executive Summary

Recent engineering analyses of the integrated Ares-Orion stack show that vibration levels for Orion crews have the potential to be much higher than those experienced in Gemini, Apollo, and Shuttle vehicles. Of particular concern to the Constellation Program (CxP) is the 12 Hz thrust oscillation (TO) that the Ares-I rocket develops during the final ~20 seconds preceding first-stage separation, at maximum G-loading.

While the structural-dynamic mitigations being considered can assure that vibration due to TO is reduced to below the CxP crew health limit, it remains to be determined how far below this limit vibration must be reduced to enable effective crew performance during launch. Moreover, this “performance” vibration limit will inform the operations concepts (and crew-system interface designs) for this critical phase of flight. While Gemini and Apollo studies provide preliminary guidance, the data supporting the historical limits were obtained using less advanced interface technologies and very different operations concepts.

In this study, supported by the Exploration Systems Mission Directorate (ESMD) Human Research Program, we investigated display readability—a fundamental prerequisite for any interaction with electronic crew-vehicle interfaces—while observers were subjected to 12 Hz vibration superimposed on the 3.8 G loading expected for the TO period of ascent. Two age-matched groups of participants (16 general population and 13 Crew Office) performed a numerical display reading task while undergoing sustained 3.8 G loading and whole-body vibration at 0, 0.15, 0.3, 0.5, and 0.7 g in the eyeballs in/out (x-axis) direction. The time-constrained reading task used an Orion-like display with 10- and 14-pt non-proportional sans-serif fonts, and was designed to emulate the visual acquisition and processing essential for crew system monitoring.

Compared to the no-vibration baseline, we found no significant effect of vibration at 0.15 and 0.3 g on task error rates (ER) or response times (RT). Significant degradations in both ER and RT, however, were observed at 0.5 and 0.7 g for 10-pt, and at 0.7 g for 14-pt font displays. These objective performance measures were mirrored by participants’ subjective ratings. Interestingly, we found that the impact of vibration on ER increased with distance from the center of the display, but only for vertical displacements. Furthermore, no significant ER or RT aftereffects were detected immediately following vibration, regardless of amplitude. Lastly, given that our reading task required no specialized spaceflight expertise, our finding that effects were not statistically distinct between our two groups is not surprising.

The results from this empirical study provide initial guidance for evaluating the display readability trade-space between text-font size and vibration amplitude. However, the outcome of this work should be considered preliminary in nature for a number of reasons:

1. The single 12 Hz x-axis vibration employed was based on earlier load-cycle models of the induced TO environment at the end of Ares-I first stage flight. Recent analyses of TO mitigation designs suggest that significant concurrent off-axis vibration may also occur.
2. The shirtsleeve environment in which we tested fails to capture the full kinematic and dynamic complexity of the physical interface between crewmember and the still-to-be-matured helmet-suit-seat designs, and the impact these will have for vibration transmission and consequent performance.
3. By examining performance in this reading and number processing task, we are only assessing readability, a first and necessary step that in itself does not directly address the performance of more sophisticated operational tasks such as vehicle-health monitoring or manual control of the vehicle.

1.0 Introduction

NASA's Constellation (Cx) Architecture proposes reinvigorating manned space exploration through the development of a new generation of flexible launch vehicles. The architecture selected for the crew launch vehicle Orion reflects a return to a Mercury-Gemini-Apollo-like "capsule" design, but with a larger crew size and modern, more sophisticated interfaces and operations concepts.

One of the key design goals of the Shuttle era was to make the "ride" easier so as to permit teachers and other non-astronauts to travel into space. Thus, Shuttle maximum G-loads were limited to 3.0 G and vibration loads reduced to around 0.1 g. With the return to pre-Shuttle-era "stack" launch and "capsule" re-entry architectures, challenging induced environments not experienced since the Apollo era are now back in the picture. Indeed, G-loading is expected to peak at 3.8 Gx nominally on ascent and even higher during re-entry. (Note: Gx refers to the sustained G-load eyeballs in/out, Gy refers to eyeballs side-to-side, and Gz refers to eyeballs up/down. We will use "g" (measured 0-to-peak, which for a single frequency waveform is 1.4 times the RMS, or root-mean-squared value) to refer to vibration level.) Final Ares-Orion vibration specifications remain unknown, but without effective mitigation could exceed the 0.25 g (at 11 Hz) crew vibration limit specified for Gemini and Apollo (Grimwood, Hack, & Vorzimmer, 1969). Exposure to high sustained and transient gravito-inertial forces will generate considerable human-performance challenges, some old, but others new.

Our current knowledge of the effects produced by elevated Gx and/or vibration on spaceflight-relevant aspects of human performance is limited to practical knowledge from the Mercury, Gemini, and Apollo flights and a small number of 1960s era studies on the 20-G centrifuge at Ames. There is effectively no knowledge of the effects of elevated Gx and high vibration on crew performance in a modern glass cockpit (such as the cockpit envisioned for Orion), where electronic (soft) crew-vehicle interfaces require novel methods of crew-vehicle interaction not encountered in earlier vehicle designs.

One of the foundations of crew operational capability in glass cockpits is alphanumeric character readability on electronic display formats. Accordingly, the aim of the current study was to provide objective performance data on the readability of alphanumeric symbology during elevated induced Gx-plus-vibration environments similar to those that may be experienced by the crew during the

harshest phase of an Orion ascent (i.e., immediately prior to first-stage separation). The limited goal of this study was to provide some of the quantitative human-performance data necessary for Constellation to establish validated human-system display-interface requirements pertinent to crew performance during elevated combined Gx and vibration exposure. Ultimately this information may also be used to assist in the interface design optimization process (e.g., font-size selection, display element density, etc.), and to help guide operations planning for Constellation spacecraft.

2.0 Problem Statement

The Constellation Program (CxP) Human Systems Integration Requirements (HSIR) document (CxP70024, Rev. C) currently contains objective numerical vibration limits for the protection of crew health and safety. The limit of 3.7 g (0 to peak) is based on the 0.6 g RMS ISO 2631-1 (1997) frequency-weighted health-risk boundary, which was derived primarily for upright body posture and z-direction vibration for short-duration 1-minute exposures (Figure 1). There is only minimal validation of this limit for Gx loading in a supine posture, and at that, only for 1.0 Gx-bias (Temple, Clarke, Brinkley, & Mandel, 1964). Importantly, the vulnerability to vibration is greatly altered by biomechanical compliance, which itself is greatly altered by sustained G-loading and one’s postural orientation with respect to the G-load vector.

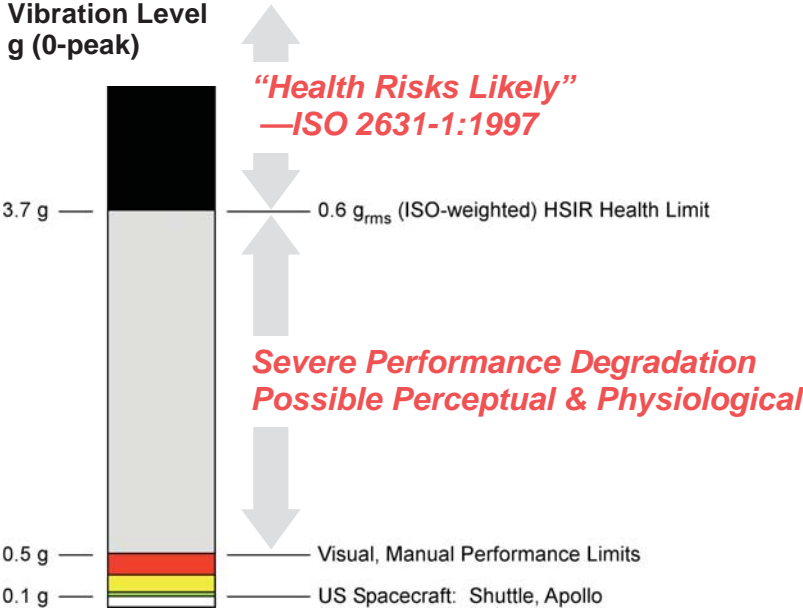

Figure 1. Vibration levels and human health and performance impacts.

While HSIR does list a number of performance requirements relevant to the induced gravito-inertial environments experienced during dynamic phases of flight, up to this point it has not provided explicit vibration limits for achieving acceptable crew performance. In part, this initial “apparent” gap in HSIR was deliberate; as originally intended, HSIR separates requirements related to interface design and crew performance from those explicitly tied to quantifiable induced environment impacts on crew health. In fact, crew performance is implicitly subject to multiple highly interrelated considerations, including induced environments as well as interface, task, and procedure design.

However, the pre-SRR CxP requirements writing process formally discouraged anything other than “single-input single-output” types of requirements where each requirement specified only a single parameter to be verified without modulation by other exogenous variables. HSIR took the philosophy of enumerating a series of overall system requirements for critical crew-vehicle interaction and operational considerations that must be maintained during flight (e.g., display legibility, control operability, error rates, workloads, handling properties). Unlike the clear engineering vibration limits for human health, the human-system performance requirements provide little direct guidance to Ares I propulsion and structural engineers or to Orion interface designers on how to deal with induced vibration and G-load factors.

In summary, while HSIR clearly limits vibration in order to support crew safety it currently does not offer clear guidance as to what levels are needed to ensure crew operational capabilities. Because of the absence of predictive analytical tools, HSIR human performance requirements will have to be verified in flight-like tests with representative induced environments including acceleration and vibration as well as other factors. Such late verification of human-performance requirements by whole human-system testing is burdensome on vehicle designers and could prove costly for both budget and schedule. This also greatly increases program risk because determination of whether or not the HSIR system requirements are actually met will occur so late in the design process. Validated assessment of the impacts on human performance due to combined vibration and G-loading earlier in the design process would provide Orion-Aries designers with valuable direct and early information related to the human-performance ramifications of different design trade-offs. The goal of this highly focused study was to provide critical human-performance data by quantifying the performance impacts of the anticipated Ares-Orion vibration and Gx-loads during ascent for a limited range of display design parameters; these parameters (e.g., two font sizes, one viewing distance, one level of display element crowding) were judiciously chosen based on the currently anticipated Orion cockpit display design.

2.1 Gx-Loading Impacts on Human Visuomotor Performance

In the years leading up to and including the Mercury missions there was considerable focus on human performance under hypergravity conditions, especially the moderate to severe, largely transverse G-forces experienced for a few minutes during launch and re-entry. Humans typically show limited tolerance for positive (+Gz, downwards from the head to the feet, eyeballs down) G-force exposure, showing significant reaching errors at only +2 Gz (Cohen, 1970a, 1970b), and blackout and ultimately loss of consciousness under sustained exposure to +5 Gz (Cochran, Gard, & Norsworthy, 1954). Humans, however, have considerably greater tolerance for transverse G-forces (Gx, into or out of the chest, eyeballs in or out) and can experience sustained exposures above +10 Gx without serious physiological impairment.

Although the peak levels of transverse G-force exposure expected during a nominal Orion-Ares launch and re-entry will be moderate (in the +3 to +6 Gx range) and Gx tolerance is robust, there is reason to anticipate meaningful compromise in human performance. Performance degradation will likely include: increased error rates; increased reaction times; decreased sensorimotor accuracy; decreased peripheral visual fields; decreased visual sensitivity and acuity; eye movement impairments; delays in task completion; and potential motion sickness, vertigo and other perceptual distortions. These concerns were mitigated for the Mercury program, although the safety margin was likely tight. The safety expectation today for Orion-Ares is far more stringent and the human-system interactions will be far more complex than 45 years ago. Thus, the many design factors that

influence crew performance under transverse G-loading deserve greater attention so that crew safety and performance efficiency during the key mission phases of launch and entry can be optimized (and risks therefore minimized). This will require appropriate interface/display design, operations planning, and crew training.

Current engineering analyses of the Orion-Ares stack show that in some design options, vibration levels within Orion may be much higher than those within the Mercury, Gemini, and Apollo vehicles. Specifically, thrust oscillations due to internal pressure fluctuations typical of solid rockets (e.g., Prevost, LeQuellec, & Godon, 2006; Fabignon et al., 2003), but not observed in Shuttle or earlier liquid-fueled rockets, and high aeroacoustic loading on the crew vehicle's outer moldline during launch (Himmelblau, Fuller, & Scharton, 1970) will impart significant structural vibration to the Orion crew compartment. These external vibratory loads will affect the seats affixed to the vehicle frame as well as the crew within the vehicle and, consequently, display visibility and control input device operation during ascent and descent. While the magnitude and frequency content of the entire ascent vibration (i.e., for lift-off and "max-Q" flight) are not yet completely understood, they have been largely characterized by Constellation designers and analysts for one of the most challenging phases of flight: the time immediately before the end of the first-stage during which both vibration and g-loading will be at very high levels. Ares engineers expect this vibration to be dominated by a Gx thrust oscillation, along the axial length of the vehicle, which will have narrow bandwidth energy focused at temporal frequencies near 12 Hz. In addition to properties inherent to Orion's current seat-palette design, some of the Ares thrust oscillation mitigation design options being considered will potentially induce significant off-axis (gy and gz) vibration.

The anticipated G-loading and vibration along the x-axis in isolation and combination have the potential to cause a number of adverse effects on human vision and visuomotor performance:

- *Impaired accommodation and decreased static visual acuity.* This is due to mechanical effects on the optics of the eye and to excessive tearing (worse for -Gx loads). Chambers and Nelson (1961) reported some difficulty focusing at +3 Gx. White and Jorve (1956) found that targets needed to be twice as big to be seen at +7 Gx than at 1 Gx.
- *Decreased visual sensitivity.* G-forces produce an effective dimming of visual stimuli due presumably to some reduction in retinal blood flow. Chambers and Hitchcock (1963) describe a 50% increase in the contrast needed to make threshold discriminations at +5 Gx.
- *Increased reaction/response time.* Reaction times to visual stimuli are increased during exposure to hypergravity (Canfield, Comrey, & Wilson, 1949) although isolating sensory latency effects from cognitive effects or motor output delays/difficulties is problematic. In reach response tasks, participants were on average ~50 ms slower at +6 Gx than at +1 Gz (Kaehler & Meehan, 1960). In a visual spatial response task described in Chambers and Hitchcock (1962, 1963), reaction times were elevated at +6 Gx. The latter study also found that response times in mission-related tasks can be elevated by more than a second (see "Workload" bullet below).
- *Decreased field of view.* There is little quantitative information about the effect of transverse acceleration. Chambers (1961) found some loss of peripheral visual field at +6 Gx, which increased dramatically at +12 Gx with some experiencing total blackout at +15 Gx. For positive acceleration (+Gz), the field is narrowed to an arc of less than 46°, on average at +4.5 Gz, but the range across participants of this effect is ±33% (Zarriello, Norsworthy, & Bower, 1958). A similar variability across participants for transverse accelerations would suggest that

many astronauts might experience some decrement in peripheral vision at G-loads as low as +4 G_x.

- *Eye movement impairment.* Little is known about the effects of G_x-loading on visual targeting with saccadic eye movements, pursuit eye movements, and the associated dynamic visual acuity. However, the time on target for smooth pursuit tracking was degraded by 20-80% with a +G_x profile simulating re-entry of a Mercury capsule (Clarke et al., 1959). Given pursuit's role in dynamic visual acuity, one would anticipate a concomitant reduction in dynamic visual acuity as well, which could impact visuomotor control during off-nominal vehicle flight.
- *Increased workload.* In the Schafer and Bagian (1993) study on reaching under moderate G_x-loading, only 60% of experienced astronaut/pilot participants were willing to proceed up to +5 G_x from +4 G_x and only 30% agreed to experience +6 G_x. Performing gross limb movements in protective suits at these moderate levels of +G_x is an unpleasant and highly stressful experience. Although side-controller responses will be much less impacted by these moderate G_x levels, there is reason to expect some increase in workload for any visuomotor responses above +3 G_x, especially when coupled with vibration. Furthermore, the response to discrete interruptions can be dramatically increased during G-loading suggestive of cognitive/attentional deficits typical of excessive workload. In launch-scenario studies in which intervening responses to discrete events were required in addition to the primary flight control task, participants' response times were increased on average by about 0.5 s (Chambers, 1961; Chambers & Nelson, 1961; Chambers & Hitchcock, 1963). In response to one category of event (the NO-LIGHT indicator mode), reaction time was, on average, about 1.5 s longer; thus, this reaction time deficit can potentially be considerable. It should be emphasized that while these delayed responses to discrete caution and warning type events occurred during the dynamic (i.e., G-loaded) runs, the events themselves occurred during periods of low G-loading (always below +2 G_x). Thus, the data indicate that G-force effects on cognitive processing can persist for durations as long as several minutes and thus impact reaction time during periods of little or no G-loading. Similar aftereffects were also observed in a complex discrimination task with elevated reaction times and errors both during and after exposure to +6 G_x (Chambers & Hitchcock, 1963). Therefore, there is reason to expect significant aftereffects of exposure to high G_x-loading if the task has a high workload demand.

2.2 Vibration Impacts on Human Visuomotor Performance

2.2.1 Display Vibration

Vibration-induced lateral image motion smaller than ± 1 arcmin of visual (in terms of font size this is ± 0.5 point at a 24 inch viewing distance) is below human visual resolving capability (Howard, 1982). Larger amplitude vertical or horizontal image motion with low-frequency content (up to about 1 Hz) can effectively be tracked by the pursuit system (albeit with a latency of ~ 100 – 150 ms, see Tyachsen & Lisberger, 1986). Pursuit enables humans to read displays when they oscillate slowly with respect to the observer, although such “dynamic acuity” conditions will likely increase workload and the risk of motion sickness. Higher frequency oscillations (> 2 Hz) will destabilize and blur the retinal image and will impact legibility at standard font sizes, with potential effects including increased reading time, more frequent reading errors, and increased reading difficulty (O'Hanlon & Griffin, 1971). The pursuit system provides limited tracking capability at frequencies between 2 and 5 Hz (Goldreich, Krauzlis & Lisberger, 1992) but none at the 12-Hz frequency used in this study.

2.2.2 Observer Vibration

To compensate for self-motion, humans have a vestibular ocular reflex (VOR) akin to a gyroscopic stabilization system. When the observer is subjected to low temporal frequency vibration, the VOR is normally able to stabilize images on the retina nearly perfectly (with a latency on the order of 10–15 ms). The canal-ocular-reflexes (i.e., rotational VORs) can compensate for head/body rotations at frequencies up to about 20 Hz (albeit with increasing phase lags for frequencies >12.5 Hz) (see Ramachandran & Lisberger, 2005). The otolith-ocular-reflexes (Tilt VOR) generally compensate for head/body tilts below ~0.5 Hz movements. For linear motion, the translational VOR compensates for frequencies above ~0.5 Hz (Paige & Tomko, 1991), although typically with a gain less than unity, thus allowing residual retinal motion and image blurring. In monkey studies of the high-frequency behavior of the translational VOR, the fore-aft VOR also remained compensatory out to about 20 Hz with undiminished gain and little phase lag out to ~12 Hz (Angelaki, 1998). More specifically, during fore-aft self-motion (i.e., g_x vibration), this VOR must compensate for changes in both vergence (near-far) and version (left-right and up-down) demand, which is a function of both target eccentricity and distance. From the monkey data, for a 0.4 g stimulus at 12 Hz with a viewing distance of ~18 inches (similar to our conditions; see below), the versional response is expected to be under-compensatory (about 75% of that necessary for ideal stabilization of eccentric targets) and the vergence response is expected to be over-compensatory by about a factor of two (McHenry & Angelaki, 2000). Thus, one would expect significant blurring of the stimulus (particularly from the under-compensated up-down and left-right motion of eccentric targets) that would act to decrease acuity. Although we know of no study of the human translational VOR at 12 Hz, the monkey data are consistent with older human studies that showed that 0.5 g RMS in the 5-20 Hz range along the up-down axis causes a nearly three-fold decrease in acuity for short viewing distances (15.5 inches) (O'Briant & Ohlbaum, 1970).

2.3 Prior Study Using Vibration-Only Conditions

To further validate our selected trade-space and thus minimize our participants' exposure to the full 3.8 Gx plus vibration environment, the current experiment builds upon our previous study with 16 participants who experienced a range of 12-Hz g_x vibration levels (0, 0.15, 0.3, 0.5, and 0.7 g) in a supine position (i.e., under a 1-Gx load) (Adelstein et al., 2009). Under these conditions, we measured alphanumeric readability of 10-pt and 14-pt size of a sans-serif non-proportional font (Lucida Console) at a display distance of 18 in (~46 cm). As shown in Figure 2, we found significant decrements in performance (i.e., compared to the no-vibration conditions, there was a nearly 7-fold increase in the error rate and a 50% increase in response times for the small font at the 0.7 g vibration level) and no impact for either font size at the lowest non-zero level tested (0.15 g). This provides empirical evidence that 0.0 to 0.7 g is a good *a priori* estimate of the appropriate 12-Hz vibration amplitude range necessary to examine combined Gx plus vibration effects on font readability that will likely provide an anchor point of no-effect and a point with a likely significant effect for both font sizes tested.

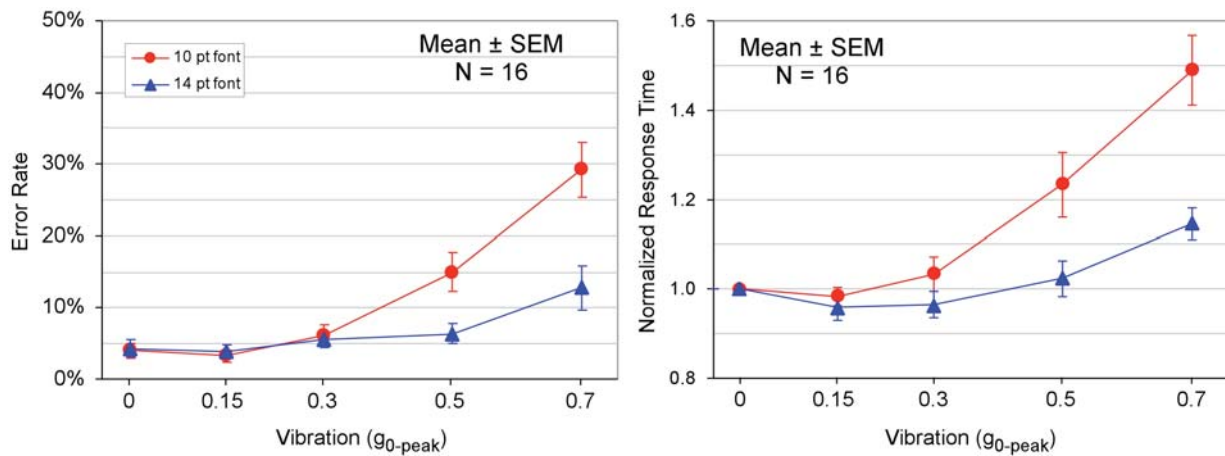

Figure 2. Mean \pm Standard Error of the Means (\pm SEM) across 16 participants for error rate (left panel) and response time (right panel) effects due to Gx vibration (0 to 0.7 g) in the supine position (i.e., sustained 1.0 Gx) on the readability of two font sizes.

2.4 Combined Gx-Loading and Vibration

From the above literature review and previous data from our laboratory, it is clear that both Gx loading and vibration in isolation produce significant adverse effects on visual and visuomotor performance. Clearly, the combination of these two stimuli will also have performance impacts, but it is difficult to make quantitative predictions because the interaction between the two may be nonlinear. Specifically, Gx-loading can dramatically change human biomechanical compliance, thus altering how seat vibration is mechanically absorbed to generate body vibration. In particular, for a 0.5 g vibration at 12 Hz, biomechanical impedance for a 4 Gx load is nearly 3 times higher than that at a 1-Gx load (Vykukal, 1968; Vogt et al., 1973). There are reasons to expect that Gx-loading may make the effect of vibration on performance worse, but also reasons to expect that Gx-loading may, in fact, reduce the effects of vibration on performance. Furthermore, the nature of the interaction may differ depending on the task (e.g., reading may be better, but manual control worse). Thus, in the absence of any theoretical framework for predicting the interaction between Gx and vibration on human performance, we must rely on empirical studies. Unfortunately, there are very few existing reports of combined Gx-loading and vibration on human performance, comprising only a pair of studies conducted at Ames in the mid-1960s by Vykukal and his colleagues.

The Vykukal and Dolkas study (1966) was performed with a 3.5 Gx sustained load and an 11 Hz vibration that ranged up to 1.65 g. From the subjective judgments of expert pilots during a Gemini abort part-task simulation, they concluded that vibration at or below 0.14 g would not compromise performance or mission success. However, at 0.3 g, they concluded that crew operations should be limited to coarse visual and manual tasks and speech. At 0.53 g, they concluded that only simple visual tasks or button presses could be reliably performed. At the highest levels tested, 1.36 and 1.65 g, they reported serious compromise in all the visuomotor tasks they examined. However, another study that used a 3.85 Gx sustained G- load and vibration primarily at 11 Hz with significant power at 33 Hz and 55 Hz (Clarke et al., 1965) found at least rudimentary gross dial reading capabilities

were possible at vibration levels as high as 2.4 g. A summary of the Vyukukal and Dolkas (1966) limits and vehicle specifications and levels are shown in Figure 3.

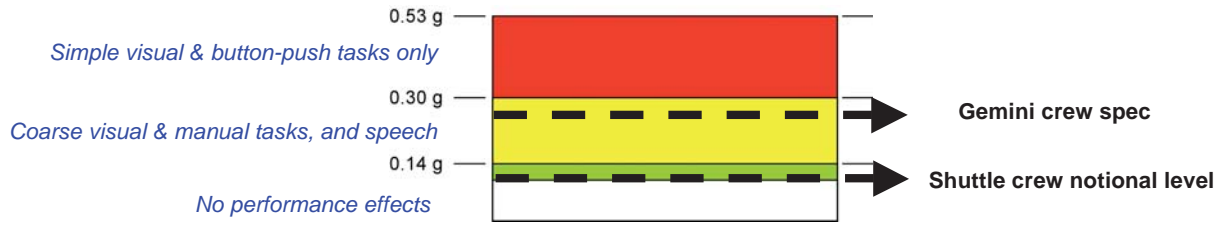

Figure 3. Human performance limits from Vyukukal and Dolkas (1966) with Gemini specification (0.25 g) and Shuttle notional level (0.1 g measured on the flight deck, inside the console) for comparison.

It is based in part on these findings that the Gemini vibration specification of 0.25 g was set (Grimwood, Hacker, & Vorzimmer, 1969). (Putatively, Shuttle crews generally experience vibration of only ~0.1 g during ascent at max-Q, according to accelerometers mounted inside the flight deck console rather than from seat measurements.) It must be emphasized that these findings were obtained for vibration at 11 Hz while using 45 year-old simple interface technologies (i.e., mostly mechanical “steam” gauges and blinking lamps, not modern computer-generated symbology). Although the above findings do provide useful guidance to Constellation, one cannot immediately extrapolate these findings to 12 Hz vibration conditions, to complex digital interfaces, or to modern system monitoring or display navigation tasks.

2.5 Targeted Trade Space

A full evaluation of the impacts of combined G and vibration on human performance was well beyond the scope of this study. It was therefore necessary to severely limit the trade-space examined and to focus tightly on the conditions most acutely relevant to Ares-Orion designers. Thus, we examined only a narrow range of the stimulus space tailored to encompass: 1) the vibration region within which we expect a transition from no impact to serious performance degradation; 2) only one operationally relevant issue, font readability; and 3) only two levels of the manipulated display parameter (font size).

2.5.1 The Induced Environments

The peak G-load expected during Ares-I ascent is 3.8 Gx, experienced just prior to first-stage separation. As currently modeled, Ares-I thrust oscillation in conjunction with the structural dynamics of the integrated Ares-Orion stack will focus vibrational energy at 12 Hz along the vehicle and crew member’s body x-axis (i.e., it will directly add and subtract from the sustained Gx-load). Consequently, we limited our examination to a single axis G-load of 3.8 Gx with a superimposed Gx-vibration between 0 and 0.7 g at a single frequency of 12 Hz. Our goal was to identify the effect on text readability of varying levels of Gx vibration within this range.

2.5.2 The Task

To serve the purposes of this study, we developed an objective “readability” task. The rationale was to examine a task that is at a slightly higher level than a simple legibility or acuity task, which would involve the mere identification of isolated individual letters. By contrast, most system monitoring

tasks performed by Orion crewmembers will require locating, then reading, and then cognitively evaluating text and/or numerals (e.g., “Is a particular display value outside the nominal range?”) on potentially crowded and complex visual displays. Our reading task emulates the basic visual information processing that is a required part of crew system monitoring. The task comprises the following six steps:

1. Visually acquire the relevant information cell embedded within a crowded display (with other irrelevant adjacent cells).
2. Make an eye movement to fixate that cell.
3. Select a target string of three digits while filtering out closely adjacent digit triads.
4. Read the digits in the target.
5. Make a simple two-alternative forced-choice cognitive judgment based on the relative magnitudes represented by the digits.
6. Press one of two response buttons.

The data from our measures of task performance (accuracy and response time) will provide a trade space indicating the effects of vibration on this numeric readability task.

2.5.3 The Display/Interface Arrangement

The Orion cockpit design will be vastly different from any that NASA has ever flown. The limited cockpit real estate will require that nearly all systems information be presented electronically in rather crowded visual formats. Current design calls for two astronauts (Operators 1 and 2) to fly the vehicle. Each will control a single, small (~8.5 X 11 in, or 21.5 X 28 cm) LCD monitor (Honeywell DU 1310) located approximately 18 in (46 cm) directly in front of them, with a third, shared monitor located between them. During high-G and high-vibration flight phases, the astronauts will use an armrest side-mounted hand-controller, which acts as a cursor control device with additional co-located buttons, to interact with the displays.

It will be especially critical for crewmembers to be able to rapidly and accurately navigate between and interact with the electronic interfaces. In our experiment, we sought to emulate the visual features of the commander/pilot primary display. Because our participants did not directly interact with the display, we did not emulate a side-mounted hand controller; rather, we provided a simple binary response device.

2.6 Summary

The elevated vibration combined with the Gx loading expected during the dynamic phases of Ares-Orion flights, specifically during periods of thrust oscillation, are expected to significantly degrade human sensorimotor function in ways that could directly impede the safety and efficiency of vehicle operations. Although some of the relevant parametric space has been examined subjectively in limited earlier studies, advances in human-factors methodologies (in conjunction with the novelty of the Ares-induced environment, the Orion cockpit design, and the associated operational concepts) necessitate that NASA revisit this critical issue. A single study cannot explore the entire relevant parameter space. Rather, our goal is to apply modern, more sensitive and objective human-performance analysis techniques to quantify the impacts of the most likely combined Gx-plus-vibration environment on the readability of numeric symbology embedded within flight-like display layouts. This approach recognizes information acquisition as a fundamental precursor to any

operational system-monitoring task during ascent. Thus, our findings will contribute to the development of a trade space characterizing crew capability as a function of cabin vibration.

3.0 Facilities

Two principal facilities were used to conduct these studies: the 20-G Centrifuge and the Fixed-Base Vibration Platform in the Intelligent Spacecraft Interface Systems (ISIS) Laboratory. Both of these facilities are located at NASA Ames Research Center (ARC).

3.1 Fixed-Base Vibration Platform/Chair

The Fixed-Base Vibration Platform located in the ISIS Lab was used in these studies primarily to familiarize participants with the vibration levels they would experience during the test sessions in the centrifuge and to train them on the number-reading task. While baseline reading task data (i.e., performance at 1 G with no vibration) were collected, they are not included in the analyses presented in this report. The platform, vibration generation system, and chair used in the fixed-based familiarization and training component of this study are described in Adelstein et al. (2009).

The vibration platform consists of the actuator and control components of a commercial off-the-shelf home-entertainment chair product (D-Box Technologies, model Quest). The vibration platform includes three actuators in a tripod arrangement bolted to a welded steel-tube frame plus the actuators' controller. By selectively activating different combinations of actuators the D-Box control firmware enables control of displacement (and consequently vibration) in the body x-axis translation, roll rotation about the body z-axis, plus pitch rotation about the body y-axis. The actuator controller is interfaced as a standard USB sound device to a standard Windows personal computer. A padded surgical examination chair was secured in a recumbent orientation via a rigid wooden-box structure bolted to the vibration platform steel-tube frame.

As shown in Figure 4, support for the participant's head in the General Population study (Experiment 1A) was provided by a rigid wooden headrest affixed below to the wooden box and covered above by a flat foam pad. Headrest distance from the seat pan was adjustable in the horizontal plane to accommodate differences in participant torso length. The gap between the headrest and the surgical seatback was filled with replaceable foam blocks to provide comfortable support for the participant's neck and shoulders.

For the Crew Office study (Experiment 1B), the thickly padded back of the surgical chair was replaced by a thinly padded sheet aluminum reinforced by a structural aluminum frame that more closely matched the structural characteristics of the vibration chair mounted on the centrifuge described below. Headrest-to-seat-pan distance for the revised fixed-base chair was also adjustable; in this case, by simply relocating the foam pad location on the aluminum seat back.



Figure 4. Ames Research Center's Fixed-Base Vibration Platform. Display and response device are from the previous Adelstein et al. (2009) study.

To ensure appropriate coupling between the vibration source and the participant's head, the head was secured to the headrest pad by an adjustable head strap tightened across the forehead. In order to monitor the participant's actual head vibration during the studies, a pair of lightweight (46 grams each) tri-axial accelerometers (Crossbow Technology, model CXL04GP1) were secured in a fixed-geometry configuration to the head restraint strap. Analysis of the head motion data and its correlation with task performance is beyond the scope of the present study but will be performed as part of a later report. Participant location in the seat was maintained by gravity and friction, without need for a body harness.

Details of the specific vibration stimulus profiles at the headrest employed in this study will be described below in the experimental method portion of Section 4.

3.2 Fixed-Base Display and Response Device

For this experiment, the Fixed-Base Vibration Platform was equipped with an overhead LCD monitor and a two-button response device. The display had a 15 in (37.3 cm) diagonal viewing area with a resolution of 1024 X 768 pixels. The display was set to a luminance of 130 cd/m² for a saturated white test patch (RGB values: 255, 255, 255) and operated at a refresh rate of 60 Hz. The display was supported above the participant by a rotatable swing arm bolted to its back. Because the table and swing arm were independent of the vibration platform, the LCD monitor did not physically vibrate. The swing arm allowed the monitor to be rotated away from the participant for unimpeded ingress and egress from the experiment chair.

A custom-modified manual response device was configured from a hand-held finger mouse. It contained two aviation-grade push-button switches which served as the "Yes" and "No" response buttons.

The display and experiment control program ran on a 2.66 GHz quad-core Dell Precision T3400 under the Windows Vista (32-bit) operating system. The response device was interfaced to the computer via a USB port.

3.3 20-G Centrifuge Facility

The Ames 20-G Centrifuge, shown in Figure 5, is a 58-foot diameter centrifuge with three enclosed cabs (each 7.6 ft X 5.9 ft X 6.8 ft). This study utilized one of the cabs mounted at the end of the arm (Cab A) such that the participant's head and back were ~27 ft (~8.2 m) from the axis of rotation. The participant faced inward toward the axis of rotation in a chair reclined back by 15° so that during study data collection the resultant gravitational vector, G_x , pointed in the chest-to-spine direction, consistent with what is anticipated at the end of first stage flight during an Ares-Orion launch. While the centrifuge has a maximum human rating of 12.5 G, for this experiment we did not exceed 3.8- G_x as resolved into the seat occupant's body x-axis (3.5 G radial for 20.4 RPM plus 1 G normal earth gravity). Moreover, we limited G-level ramp-up and ramp-down to an onset rate of 0.1 G/s, well below its maximum capability of ~1.0 G/s. We employed this much more benign onset rate in this experiment to minimize the rotational acceleration and associated adverse perceptual/autonomic effects.

A wireless Ethernet and Bluetooth data bridge provided communication between the onboard computers and the experiment monitor's virtual computer desktop. Video, voice, and medical data were transmitted via a slip-ring assembly above the hub of the centrifuge structure. Areas adjacent to the centrifuge rotunda were available for participant preparation, participant monitoring, pre-and post-centrifugation testing, data collection, and, if necessary, emergency medical procedures.



Figure 5. Ames Research Center 20-G Centrifuge Facility. Cab A is on the far left, closest to the technician.

3.4 Centrifuge Vibration Platform/Chair

The centrifuge vibration platform, shown in Figure 6, is based on similar actuator and control components from D-Box Technologies, onto which are mounted a custom-built aluminum sheet-metal chair and frame. The centrifuge vibration platform actuator components are larger, higher-force-capacity versions of the products used for the fixed-base portion of the study. Instead of three

actuators, the centrifuge version of the platform has four, in order to enable operation under heightened G-loading. As in the fixed-base chair, the D-Box control firmware enables controlled translational vibration in the body x-axis and rotational vibration about the body z-axis (roll) and y-axis (pitch). In this study, however, we only employ the x-axis translational capability.



Figure 6. Vibration platform and chair in the Ames Research Center 20-G Centrifuge cab.

The chair itself was padded sufficiently for participant comfort but stiff enough to ensure transmission of the commanded actuator vibration to the occupant. The vibration platform was dynamically isolated to prevent cross-coupling of platform vibration with the centrifuge's structural modes. Control of the vibration platform state was implemented from the experiment control computer located in centrifuge Cab B, nearest to the hub in Figure 5. Operator monitoring of the control computer was accomplished via a remote window on a second ground-based computer in the 20-G Centrifuge facility control room.

Tri-axial accelerometers (Crossbow Technology, model CXL10GP3) suitable for operation in the centrifuge's elevated G-environment were mounted at key locations on rigid chair structures to enable monitoring and recording of chair vibration levels during all phases of the study. To ensure constant coupling between the vibration source and the participant's head, the head was again secured to the seat headrest by an adjustable head strap across the forehead. Actual head vibration was again measured via a pair of lightweight (46 grams each) triaxial accelerometers (Crossbow Technology, model CXL10GP3) secured in a fixed-geometry orientation to the head restraint strap

to allow for a 6 degree-of-freedom reconstruction of head motion. Analysis of the head-motion data and its correlation with task performance is beyond the scope of the present study.

Participants were secured in the seat by a five-point safety harness. In their left hand, participants held an emergency signal switch that sounds an alarm to alert the control room monitors and operators whenever they failed to maintain pressure on the switch. Details of the shutdown procedures for both the vibration platform and the centrifuge are delineated in the Safety Procedures approved by the ARC Human Occupancy Review Board (HORB). Additionally, the ARC HORB reviewed and approved all equipment and systems used onboard the centrifuge for safe human occupancy.

3.5 Centrifuge Display and Response Device

The display monitor used in the centrifuge cab was identical in size and resolution and was operated at the same refresh rate and brightness as the fixed-base facility's display. The monitor in the centrifuge cab was mounted on a heavy-duty frame that could be locked in either the normal viewing orientation or upward, as depicted in Figure 6, for easy chair ingress and egress. The two-button response devices for the centrifuge and fixed-base facilities were identical.

The on-board experiment control computer housed in Cab B (nearest to the hub) was configured identically to the fixed-base system. The computer was operated in a dual-desktop mode, supporting both the participant display in Cab A and a mirrored virtual desktop at the experimenter's station. The use of virtual desktop architecture had no impact on the update rates of the control program or the participant's display.

4.0 Experiment 1A: General Population

The purpose of Experiment 1A was to ascertain the joint effects of a constant 3.8 Gx acceleration bias and various amplitudes of sinusoidal 12 Hz gx vibration on general-population participants' ability to read and process numeric symbology. All vibration was driven by a 12-Hz sinusoidal waveform input. Harmonic analysis of vibration chair accelerometer measurements indicated that at least 96% of the output waveform was concentrated at the 12 Hz fundamental.

To assess reading performance, each participant completed blocks of trials of a speeded, two-alternative forced-choice (2AFC) task under vibration (including a zero-vibration baseline). The reading was performed on a row of three closely spaced digits, which will henceforth be referred to as the target. On half of the trials, the numeric magnitude represented by the middle digit of the target lay *inside* the range established by the flanking digits; that is, they formed three-digit monotonic ascending or descending sequences (e.g., 234, 067, 942, or 432). These were designated "Yes" targets. On the other half of the trials, the center digit magnitude fell outside the range established by the flankers; that is, they were not monotonic sequences (e.g., 461, 936, 681 or 243). These were designated "No" targets. The participant's task was to classify each target as quickly and as accurately as possible. The task was designed so that participants would have to visually encode all three digits, map the visual encodings onto their respective magnitudes (called number codes in the cognitive literature; see Campbell & Epp, 2004), complete a mental computation involving those magnitudes, and make a manual response (button press) indicating the target's category membership.

The primary objective measures of performance were average response time (RT) and error rate (ER). For the purpose of this report, we elected to pool “Yes” targets erroneously identified as “No” and “No” targets erroneously identified as “Yes” into a single error rate for the purpose of this study. These measures were taken both *during* vibration exposure and immediately *after* vibration exposure. In addition, we solicited participants’ subjective ratings of difficulty following each block of trials. Thus, we were able to obtain both objective and subjective measures of reading performance under vibration and to assess whether there was any impairment in reading performance as an aftereffect of vibration.

4.1 Method

4.1.1 Participants

Sixteen healthy adults (11 men and 5 women) ranging in age from 35 to 53 (median = 46 years) participated in the study. Participants were recruited via a Center-wide electronic mail announcement at NASA Ames Research Center. Candidates completed an initial phone survey to ensure availability during testing periods and to screen for basic medical/safety qualifications. Medical disqualifiers included vision deficits (single-correction lenses were allowed); surgeries or hospitalizations within the past 90 days; unmanaged high blood pressure or heart disease; history of seizures or neurological disorders; history of neck/spine injury or disease; and weight greater than 200 lbs (> 200 lbs compromised emergency egress capability from the centrifuge).

Candidates who passed this initial screening were invited to attend a briefing that provided an overview of the study’s goals and participants’ commitments and risks. Twenty-three men and eight women who attended the briefing indicated their desire to continue to the next phase of medical screening. This phase consisted of a general physical, an ECG stress test, and a spinal x-ray survey conducted at the Ames Health Unit and local medical facilities. Nineteen men and eight women completed the medical screening tests; thirteen men and six women were deemed fully fit for participation.

As a further precaution, participants were medically monitored during their centrifuge sessions through closed-circuit video and voice communications and via medical data consisting of 12-lead ECG, heart rate, blood pressure, and blood oxygen saturation. (The Medical Monitor was also on-call for the fixed-base sessions.) Although free to do so, none of the 16 participants elected to self-terminate any of their familiarization or testing sessions due to discomfort nor were any sessions terminated for medical reasons.

4.1.2 Stimuli

To capture the essential features of the current Orion display design, we used the two anticipated Orion sizes (10- and 14-point Lucida Console, a sans-serif non-proportional font), and a crowded display filled with boxed cells of numerals to mimic a potential, basic visual parsing difficulty anticipated with Orion displays and operations.

Many candidate Orion spacecraft display formats are densely packed, containing numerous forms of graphical symbology (boxes, lines, etc.) in addition to alphanumeric symbols. Orienting to a particular parameter or alphanumeric symbol often involves making an eye movement from another display location and attentionally filtering the clutter. In an effort to embed the targets in a visual context emulating at least some of this clutter as well as incorporate orienting and filtering

requirements into the task, each target formed the middle row of three vertically aligned rows of three digits each. As illustrated in Figure 7a, each three-row group of three-digit sequences was embedded in an outline box. There were 36 boxes of various sizes on each display, in a roughly rectangular arrangement, with some of the boxes connected by white lines. On each display one box was highlighted in magenta (see Figure 7b). The middle row of digits within the magenta box formed the target for that particular trial. Any of the 36 boxes, with equal likelihood, could contain the target on a given trial, allowing for assessment of eccentricity effects in azimuth and/or elevation.

At the prescribed viewing distance of 18 inches (46 cm), a 10-pt font target (i.e., the 3-digit sequence) subtended 0.44° of visual angle vertically and 0.88° horizontally; targets composed of the 14-pt font digits subtended 0.62° of visual angle vertically and 1.24° horizontally. Measured from the mid-point of each display, the distance to the far edge of the outermost box was 12.5 degrees of visual angle in both the horizontal and vertical directions. With one exception (the box housing the target) all boxes, lines, and digits were drawn in fully saturated white (RGB values: 255, 255, 255) at a brightness of 130 cd/m^2 against a black background (RGB values: 0, 0, 0) at a brightness of 0.3 cd/m^2 . The box surrounding the target was drawn in magenta (RGB values: 254, 0, 220).

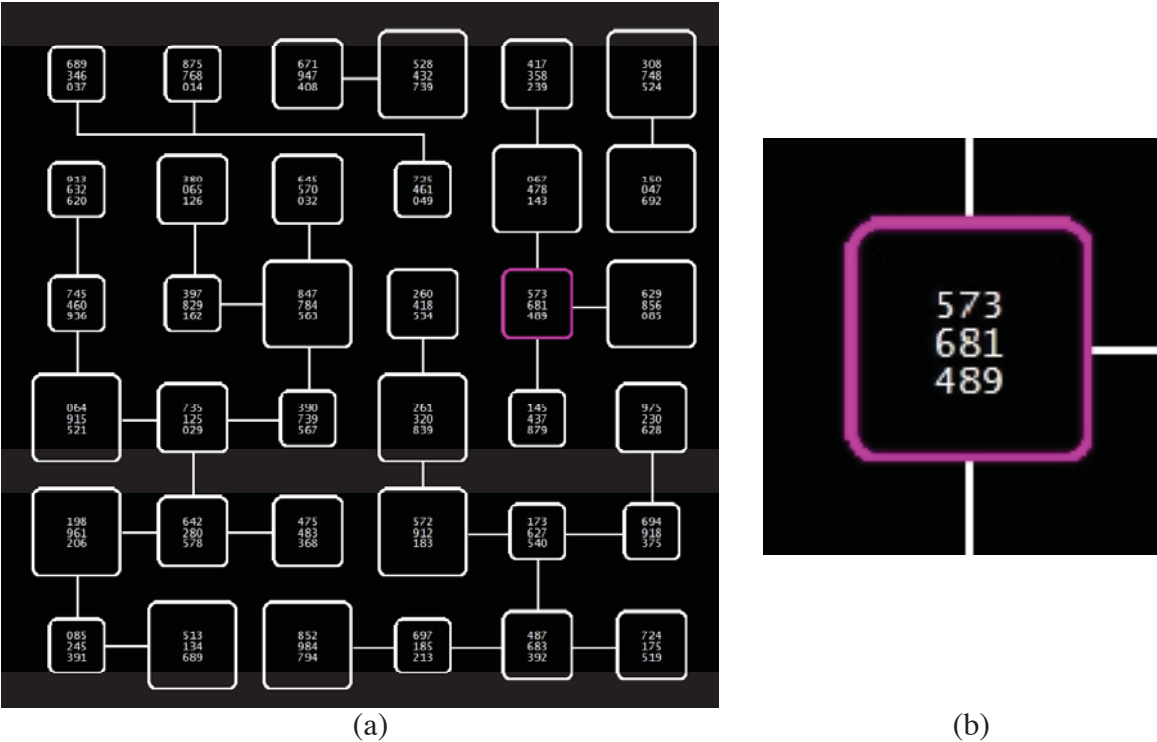

Figure 7. The reading-task display, showing (a) the entire 36-box matrix, and (b) a three-row group with center-row target. The smaller (10-point) font is shown (not to scale).

Separate sets of 224 “Yes” stimuli and 338 “No” stimuli were developed prior to the study, each consisting of three Arabic digits from the range zero (0) to nine (9). Since trial blocks were limited by time, the actual number of trials completed in a block varied. Of the first 40 trials of each block, 20 included stimuli selected randomly without replacement from the “Yes” stimulus set and 20 involved stimuli selected randomly without replacement from the “No” stimulus set. At the end of

the first 40 trials, a new sample of five “Yes” and five “No” targets was selected and made ready for presentation to the participant. This process of selection and presentation continued until either another set of 10 targets was required or the block timed out. Within the first set of 40 trials, and within each subsequent set of 10 trials, order of stimulus presentation was random.

A similar procedure was followed for assigning targets to boxes. For the first 36 trials of a block, the target location was selected randomly and without replacement from the pool of 36 possible locations (boxes). For the remaining trials in the block the selection process was repeated.

4.1.3 Procedure

Once candidates had received medical clearance they were scheduled for an initial familiarization and training session on the fixed-base platform. The principal goals of this session were to ensure that candidates: 1) were comfortable with the vibration levels that they would be exposed to in the study; and 2) learned to perform the number-reading task quickly and accurately. When candidates successfully completed this session they were then scheduled approximately one week later for a familiarization session in the 20-G Centrifuge facility.

The principal goal of this second familiarization session was to ensure that candidates were comfortable at the sustained G-loading of the centrifuge alone and then again when combined with the study vibration levels. Once candidates successfully completed this familiarization session they were deemed study participants and scheduled for their two centrifuge test sessions. The test sessions were scheduled two to twelve days after the familiarization run, with the constraint that there was at least one rest day between test sessions.

4.2 Familiarization and Training Session on the Fixed-Base Platform

Upon arrival, candidates were given a written and verbal explanation of the number-reading task. During the familiarization/training session, participants lay in the vibration chair in a semi-supine (recumbent) pose (face up, torso parallel to the ground) with hips and knees flexed and their head strapped to the headrest. The experimenter then familiarized the participant with the vibration levels they would experience in the study. In sequence, each candidate experienced 35 s of vibration at 0.15 g, 0.3 g, 0.5 g, and finally at 0.7 g. In each case, the experimenter obtained the participant’s verbal permission before initiating the next vibration period.

Following the final vibration familiarization period, each participant completed a variable number of training blocks with the 10-point font, each lasting 145 s. The actual number of trials completed within a block depended on how quickly each participant responded but typically ranged between 40 and 55. Participants were informed that they were being trained to meet task performance criteria for speed and accuracy. While the exact criteria were not explicitly identified (in fact, the criteria were an average response time less than 2.5 s with no more than two errors), participants were told that they would meet criteria if they responded as quickly as they could while making no more than an occasional error.

The display was positioned 18 in (~46 cm) from the viewer’s eye and was oriented with its long axis centered in the participant’s mid-sagittal plane, with the screen perpendicular to the viewing vector from the eye to the center of the monitor for a neutral gaze elevation (~-5° eye relative to the head,

i.e., pitched toward the feet). Room lights were turned off during experiment runs to maximize display contrast and minimize glare.

Prior to each block, participants were encouraged to respond on each trial as quickly and as accurately as possible. Each trial proceeded as follows. The participant held a two-button response device in their right hand, resting their thumb in the space between the pushbuttons. The trial began with a 0.5 s display of a central fixation cross, 36 unfilled white boxes, and connecting lines. Participants were instructed to fixate the fixation cross. When the cross disappeared, each box was filled immediately with three rows of three digits each, and the outline of one of the boxes changed from white to magenta. Participants were instructed to locate the magenta box and read the target (i.e., the middle row of digits). If participants determined that the target was a “Yes” stimulus, they pressed the right button with their thumb; if the target was judged to be a “No” stimulus, they pressed the left button. The participants then moved their thumb back to the space between the two pushbuttons. The numeric content of the display disappeared when a button press was recorded or after 3 s had passed. If no response was recorded by then the display was replaced with the words “Respond Now” for 1 s. Once a response was recorded a feedback screen appeared for 0.5 s indicating whether the response was correct (a central green checkmark) or incorrect (a central red “X”). The feedback screen was then replaced by the screen containing the fixation cross, which signaled the start of the next trial. If no response was recorded the feedback screen was omitted; the next trial (signaled by the onset of the fixation cross) commenced 2 s later.

At the end of each block of trials, participants were asked to practice responding to three questions on number readability, task difficulty, and attentional effort, using a 7-point Likert rating scale. They responded verbally to the experimenter to indicate their ratings. The three questions are listed in Table 1.

TABLE 1. POST-BLOCK QUESTIONS

<i>Q1: How difficult was it to clearly identify the individual numbers?</i>						
1 easily readable; 100% confident	2	3	4	5	6	7 unable to read; guessing
<i>Q2: How difficult was the task?</i>						
1 easy	2	3	4	5	6	7 impossible
<i>Q3: How much effort did the task require?</i>						
1 little effort; could do other things concurrently	2	3	4	5	6	7 all my effort; no spare capacity

We continued to administer training blocks until the participant met the performance criteria for response time and accuracy on two blocks (not necessarily in succession). Once the participant had reached criteria, two additional data collection blocks were performed, one with the 10-pt font number display and one with the 14-pt font number display. Following the completion of the second data collection block (which provided baseline measures of performance with zero vibration and 1.0 Gx) the head strap was released and the participant egressed the fixed-base platform. This completed the fixed-base familiarization. No participant elected to stop the vibration or terminate participation during the course of the familiarization or training, although they were instructed and reminded that this option was always available.

4.3 Familiarization Session in the 20-G Centrifuge

Approximately a week after the participants completed the fixed-based portion of the study they completed a familiarization session in the 20-G Centrifuge. This session consisted of two G-profile runs. The goal of the first run was to acquaint participants with increasing hyper-G environment, starting with 1.5 G and ultimately ramping to 3.8 G; no vibration was administered in this run. The second run was conducted at the sustained G-load of the study (3.8 G) and exposed the participant to the various vibration profiles that would be used in the test sessions.

Prior to starting the familiarization runs participants were positioned in the cab's chair with the aid of experiment monitoring personnel who adjusted and secured the participant harness restraint systems, medical monitoring equipment, and the head restraint strap. The experiment monitor and the participant together set the circumferential tension of the restraint strap around the participant's head to maintain the orientation and continuous contact of the accelerometer assembly with the participant's forehead while maintaining acceptable comfort. The head restraint was then fastened to the chair as depicted in Figure 6. The participant was instructed on emergency egress procedures (including seat harness release) by the centrifuge operator and briefed by the medical monitor.

Upon being secured in the centrifuge cab all participants completed four successive levels of centrifugation at 1.5, 2.0, 3.0, and 3.8 G (resultant sum of radial centrifugation loading and 1.0 G earth G-load). Steady state exposures at the targeted 2.0, 3.0, and 3.8 G body-referenced G-load did not exceed 2 minutes. Each level of centrifugation was separated by a minimum 30 s control/recovery period either at a full stop or at 1.5 G as shown in Figure 8. The first trial progressed from normal earth gravity, 1.0 G, (centrifuge at rest) to 1.5 G, remained at this level for up to 2 minutes, and then ramped down to a stop. After the participant verbally confirmed to the medical monitor that this low level was acceptable, the remaining levels commenced. After exposure at each of the remaining levels, the centrifuge ramped down to 1.5 G. The medical monitor verbally confirmed with the participants that they were ready to proceed to the next level.

Note that because of the fixed 15.3° seat angle, the actual net G force direction in body-referenced coordinates is dependent on the centrifuge-applied acceleration. Earth's gravity provides predominantly a z-axis (cephalocaudal or head-to-seat pan) component when the centrifuge is at rest, i.e., the body referenced (G_x, G_z) component acceleration pairs will be (0.25, -0.97). The body-referenced z-axis component is not eliminated until and unless the centrifuge reaches a rotational rate of exactly 20.4 RPM (i.e., when the exact 3.8 G_x acceleration is achieved). That is, for the targeted 1.5, 2.0, 3.0 and 3.8 G net G-loads, the respective body-referenced (G_x, G_z) component acceleration pairs will be (1.34, -0.67), (1.93, -0.51), (2.99, -0.22), and (3.80, 0). Typically, participants perceive that the increase in resultant G-load vector is accompanied by an increasing backward pitching of the fixed chair until 3.8 G when they feel as if they were lying on their back.

G-loading onset/offset rates were no greater than 0.1 G/s. A nominal G-only centrifuge run profile is shown in Figure 8.

Figure 8. Profile of G-only familiarization run.

Following the successful completion of this G-only centrifuge run, the cab door was opened and experiment monitoring personnel loosened the participant's head strap. During a 5-10 minute rest period the participant met with the medical monitor to ensure there was no reason not to proceed to the second familiarization run. All participants were deemed willing and able to proceed.

In the second run, depicted in Figure 9, the centrifuge ramped at 0.1 G/s up to a plateau of 3.8 Gx and was held at that sustained G-load for 210 s. During this plateau the first 45 s was used for vestibular stabilization and had no vibration. (This "washout" period serves as a minimum period for participant's vestibular system response transients caused by the changing centrifuge angular rate to be allowed to settle out.) The washout period was followed by a sequence of four 35-s periods, each with a constant vibration level (0.15, 0.3, 0.5, 0.7 g). This was followed by an additional 20 s of no vibration, at which point the centrifuge ramped down to 1.5 G (with no vibration). The goal of this first plateau was to allow the participants to familiarize themselves with the vibration levels to be used in the main study.

The centrifuge maintained a low G-load of 1.5 G for 150 s. During this time the medical monitor spoke with the participants to confirm they were willing and ready to proceed. If they were ready, the centrifuge again ramped up to 3.8 G as shown in Figure 9. Following the 45 s vestibular stabilization period participants were exposed to 12 Hz vibration at 0.6 g, half-way between the two highest experimental levels, and were given the opportunity to practice the number-reading task with the larger (14-point) font for 145 s (the length of an experimental trial block). This was followed by an additional 20 s of trials with no vibration, 5 s after which the centrifuge ramped down to a stop. Once stopped, the participants were asked the three Likert rating questions from Table 1. The goal of this second run was to familiarize the participant with the reading task under experimental test conditions; a non-test vibration level (0.6 g) was selected to prevent participants from receiving differential training for a particular test condition.

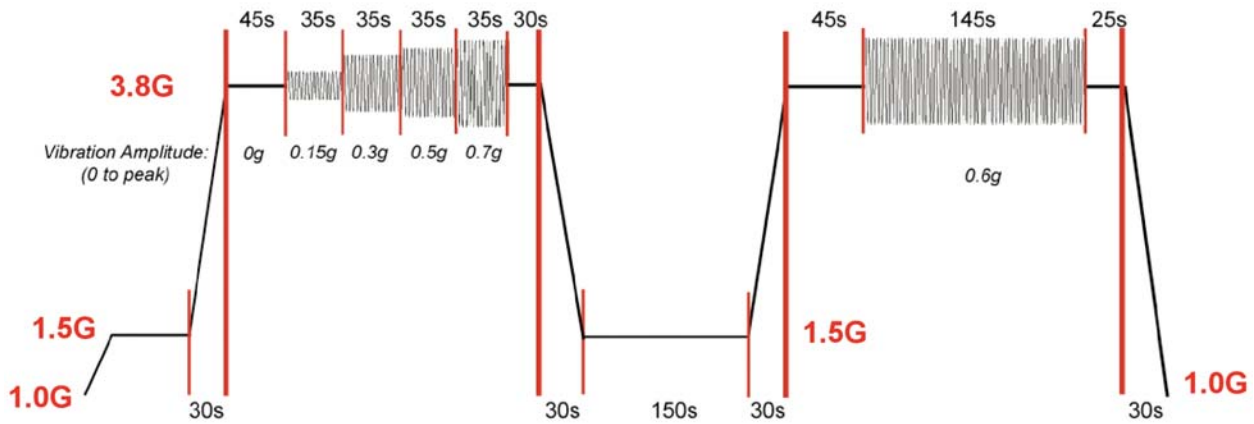

Figure 9. Profile of G-load plus vibration familiarization run.

4.4 Reading-Task Test Sessions in the 20-G Centrifuge

Participants were only permitted to proceed to the test sessions after successful completion of all vibration, acceleration, and vibration-plus-acceleration familiarization runs. The two test sessions were performed between two and twelve days after the centrifuge familiarization runs, with at least one day of rest between the two sessions. Each session consisted of a series of five test blocks, one for each vibration level (0.0, 0.15, 0.3, 0.5, and 0.7 g). All test blocks in a given session were conducted using only one of the two font sizes (10 or 14 pt) with the session font-size order counterbalanced across participants.

As depicted in Figure 10, each block began with an ~30 s ramp up (~0.1 G/s acceleration) to a 3.8 G_x plateau followed by the 45 s no-vibration washout interval. Immediately following this washout interval the vibration and reading-task trials began. After 145 s, the vibration ceased but the reading-task trials continued for an additional 20 s period, during which follow-up “recovery” data were collected to ascertain whether vibration performance aftereffects were present. The block concluded with 5 s of quiet (i.e., no test trials) followed by a ~30 s ramp down (at 0.1 G/s) to a vibration-free recovery level of 1.5 G. The inter-block vibration-free recovery period lasted 150 s. During this time participants gave their responses to the three Likert rating questions.

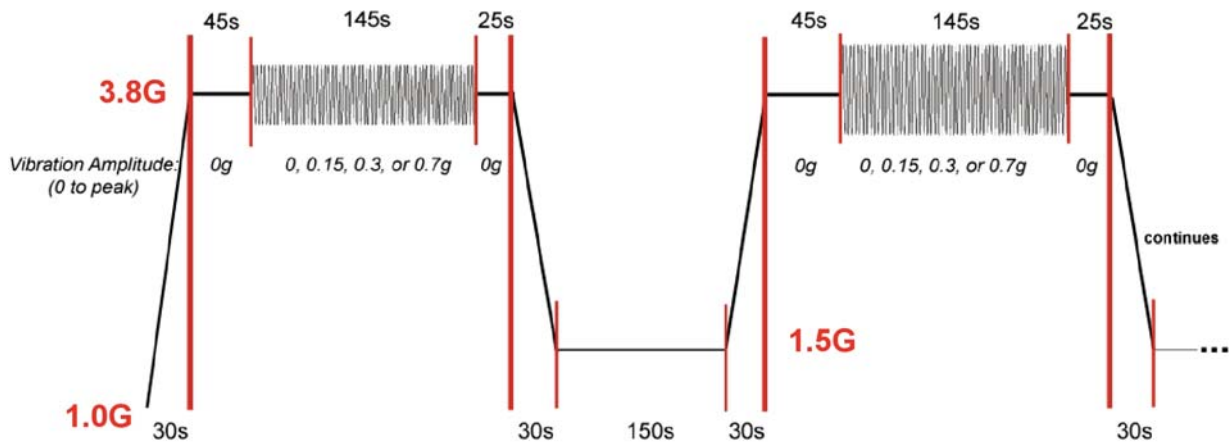

Figure 10. Profile of two blocks of trials in a number-reading test session.

Participants were informed in advance what the vibration level would be on each test block. While performing the task they were informed when there were 60 s and when there were 5 s of vibration remaining and were encouraged to continue responding when the vibration ended (i.e., for the 20 s of follow-up trials). Prior to each block the medical monitor reminded the participant that the session could be terminated if they experienced any discomfort or distress.

In each session the participant completed three blocks of trials before a ten-minute break period, then completed two additional blocks for a total of five trial blocks per session. The order of vibration level (0-0.7 g) was determined via a quasi-Latin square design (Williams, 1949); each participant retained the same order for his or her second test session.

Each trial sequence was identical to the trials administered in the fixed-based phase. Trials continued to appear for the entire 165 s interval (145 s with vibration, 20 s without) following the washout period. Participants were instructed to keep on responding without pause when the vibration ceased and to continue until the last trial of the vibration-free follow-up period was complete, at which point the G-loading began to ramp down. Participants were typically able to complete 45-60 trials during the vibration period and 6-10 trials during the follow-up period.

At the end of each block, after the centrifuge speed has ramped down to the 1.5 G recovery period (or to a complete stop following the third and fifth 3.8 Gx plateaus), participants responded to three questions on task readability, difficulty, and effort, using the 7-point Likert scale. In making their judgments, participants were instructed to consider only the vibration portion of the plateau for the four non-zero vibration levels.

Following completion of the fifth and final data collection block, participants were escorted from the centrifuge cab, examined by the medical monitor, and kept under observation for a minimum of one hour. After the second test session participants were debriefed during the observation period.

4.5 Results

4.5.1 Objective Performance Data: Effect of Vibration Level and Font Size

Data for each vibration level and font size from all 16 general-population participants are summarized in Figures 11 (Response Time) and 12 (Error rate). The inter-quartile ranges, minima and maxima depicted in these Response Time (RT) and Error Rate (ER) plots indicate both considerable inter-participant variability and that this variability increased as vibration level increased. Moreover, the median RT and ER both increase with vibration level and the increase appears more severe for the smaller font. The concurrent increase in both RT and ER indicates that participants were not performing a speed-accuracy trade-off, that is, they were not, in general, speeding up and sacrificing accuracy but rather their accuracy decreased despite their slower pace. It is important to note in Figure 12 that, despite the general trend of increasing error rate with vibration level, there was considerable inter-participant variability: a few participants were able to maintain near-perfect accuracy (ER ~ 0%) during all of their vibration runs, even at 0.5 and 0.7 g, while others performed at or near chance (ER ~ 50%) at these higher levels.

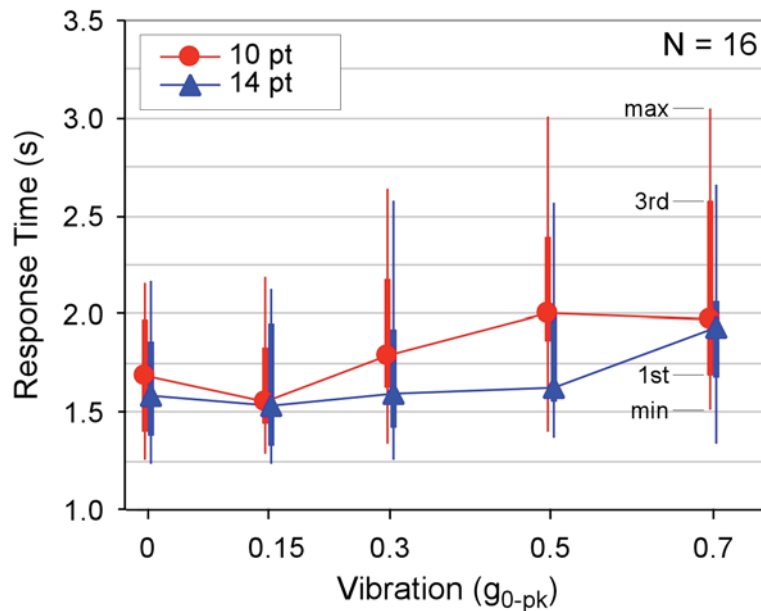

Figure 11. Median response times from 16 general population participants as a function of vibration amplitude and font size at the constant 3.8 Gx bias. Thick bars indicate inter-quartile ranges; thin bars indicate minimum-to-maximum ranges.

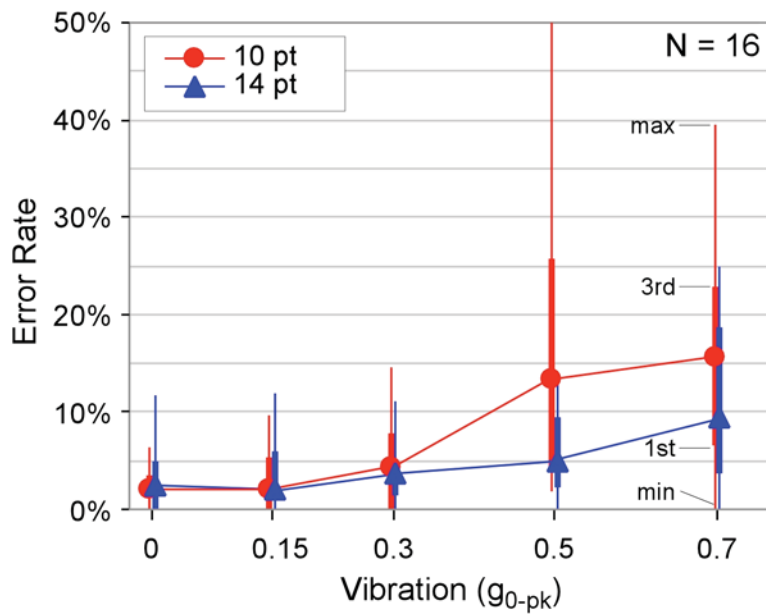

Figure 12. Median error rates from 16 general-population participants as a function of vibration amplitude and font size at the fixed 3.8 Gx bias. Thick bars indicate inter-quartile ranges; thin bars indicate minimum-to-maximum ranges.

The mean (\pm Standard Error of the Mean, SEM) response times (RT) across the 16 general population participants are plotted as a function of vibration level in Figure 13 for the two font size conditions, both during vibration (closed symbols) and immediately after the vibration ceased (open symbols). The mean baseline (0 g) RT was 1.689 ± 0.076 s and 1.629 ± 0.072 s for the 10 pt and 14 pt fonts, respectively, but rose to 2.137 ± 0.131 s (an increase of 0.45 s or 27%) and 1.924 ± 0.094 s (an increase of 0.3 s or 18%), respectively, at the 0.7 g vibration level.

Both objective performance measures (RT and ER) were submitted to three-way, mixed-design ANOVAs with vibration (5 levels) and font size (2 levels) as within-participant factors and font-size order (2 levels) as a between-participant factor. Independent ANOVAs were performed for the data collected *during* vibration and immediately *after* vibration stopped.

The ANOVA of RT during vibration demonstrated highly significant main effects of vibration level ($F_{4,56} = 20.723, p < 0.0001$) and font size ($F_{1,14} = 29.359, p < 0.0001$), as well as a significant interaction between the two ($F_{4,56} = 7.665, p < 0.0001$). Additionally, we found an interaction between font size and font presentation order, i.e., whether the series of blocks at 10-pt font preceded the 14-pt series ($F_{1,14} = 6.063, p < 0.03$). This is essentially a “session” effect, with participants responding more quickly for the 10-point font displays in the second session. Neither the main effect for presentation order nor any other interactions were significant for RT.

Post-hoc Newman-Keuls testing reveals that compared to the baseline condition, RT is significantly greater at 0.5 and 0.7 g for the 10-pt font, and at 0.7 g only for the 14-pt font ($D_{\text{critical}} = 0.163$ s, $p < 0.05$). These three data points associated with a significant increase in RT over baseline performance are indicated in Figure 13 by asterisks. Thus, at the highest vibration level tested (0.7 g), the readability of both the 10-pt- and 14-pt-font displays was significantly slower but at the 0.5 g

vibration level the readability of only the 10-pt-font display was significantly slower. The Newman-Keuls post-hoc analysis of the font-size by presentation-order interaction indicated that participants who performed the 10-pt task first improved by 0.232 s on average when they returned for the 14-pt task ($D_{\text{critical}} = 0.121 \text{ s}, p < 0.05$) while those who received the fonts in the opposite order (14 pt followed by 10 pt) slowed by an insignificant 0.087 s. The contrast for the difference between first and second sessions when RT is averaged across both font sizes, 0.073 s, was not significant (Tukey method for grouped means: $D_{\text{critical}} = 0.121 \text{ s}, p < 0.05$), failing to support a session effect.

The ANOVA of RT for trials immediately after vibration stopped did not reveal any significant effects of the preceding vibration level ($F_{4,56} = 1.718, p > 0.15$), font size ($F_{1,14} = 0.828, p > 0.37$), or the interaction between the two ($F_{4,56} = 0.736, p > 0.57$). The absence of any significant effects indicates that RT immediately following 0.15-0.7 g vibration is not distinguishable from the RT during the 20 s of trials that followed the zero-vibration block, as is apparent in Figure 13. Thus, we found no evidence of an RT aftereffect in our reading task for any of the vibration conditions tested.

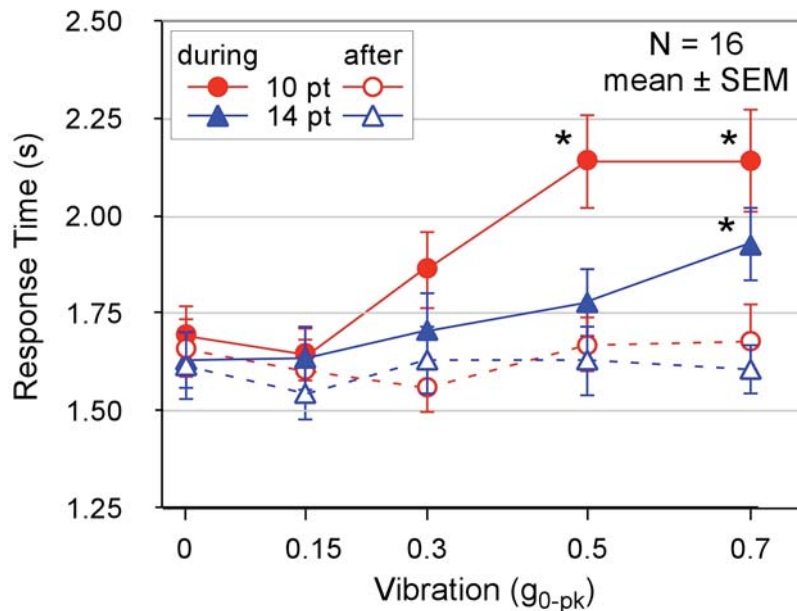

Figure 13. Mean response times (\pm SEM) of the general-population participants during (solid symbols and lines) and immediately after (open symbols and dashed lines) vibration at each of the 5 levels for 10-pt (red) and 14-pt (blue) font. Note the three points with significant ($p < 0.05$) increases over baseline. Note also the fact that performance after vibration (dashed lines) is unchanged from that at the 0 g baseline.

The mean (\pm standard error) error rate (ER) across the 16 general-population participants are plotted as a function of vibration level in Figure 14 for the two font size conditions both during (closed symbols) and immediately after (open symbols) vibration. The mean baseline (0-g) ER was $2.4 \pm 0.5 \%$ and $3.7 \pm 1.0 \%$ for the 10 pt and 14 pt fonts, respectively, but rose to $16.4 \pm 3.0 \%$ and $10.5 \pm 2.2 \%$, respectively, at the 0.7 g vibration level. Indeed, for the 10 pt font, ER rose to $17.3 \pm 3.6 \%$ at 0.5 g. The maximum differences therefore respectively reflect 3- and up to 7-fold increases for the large and small fonts.

An ANOVA of ER during vibration demonstrated significant main effects of vibration level ($F_{4,56} = 15.406, p < 0.0001$) and font size ($F_{1,14} = 12.303, p < 0.005$) as well as a significant interaction between the two ($F_{4,56} = 6.305, p < 0.0005$). No other significant main effects or interactions, including those associated with session (i.e., font order presentation), were found for RT. (An ANOVA performed on the arcsine-square root transform of RT in order to correct for unequal variances typical of small proportion measures confirmed this pattern of main effects and interactions.) Post-hoc Newman-Keuls tests revealed that compared to the baseline condition, ER was significantly greater at the 0.5 and 0.7 g conditions for 10-point font and at 0.7 g alone for the 14-point font ($D_{critical} = 6.7\%$; $p < 0.05$). The three data points associated with a significant increase in ER over baseline performance are indicated in Figure 14 by asterisks. Thus, at the highest vibration level tested (0.7 g), the readability of both the 10-pt- and 14-pt-font displays was significantly less accurate but at the 0.5 g vibration level the readability of only the 10-pt-font display was significantly less accurate.

The ANOVA of ER for trials immediately after vibration stopped did not reveal any significant effects of the preceding vibration level ($F_{4,56} = 0.658, p > 0.62$), font size ($F_{1,14} = 0.296, p > 0.59$), or the interaction between the two ($F_{4,56} = 1.299, p > 0.28$). Again, the absence of any significant effects indicates that the ER immediately following 0.15-0.7 g vibration is not distinguishable from that during the 20 s of trials that followed the zero-vibration block. Thus, we found no evidence for an ER aftereffect in any of the vibration conditions tested.

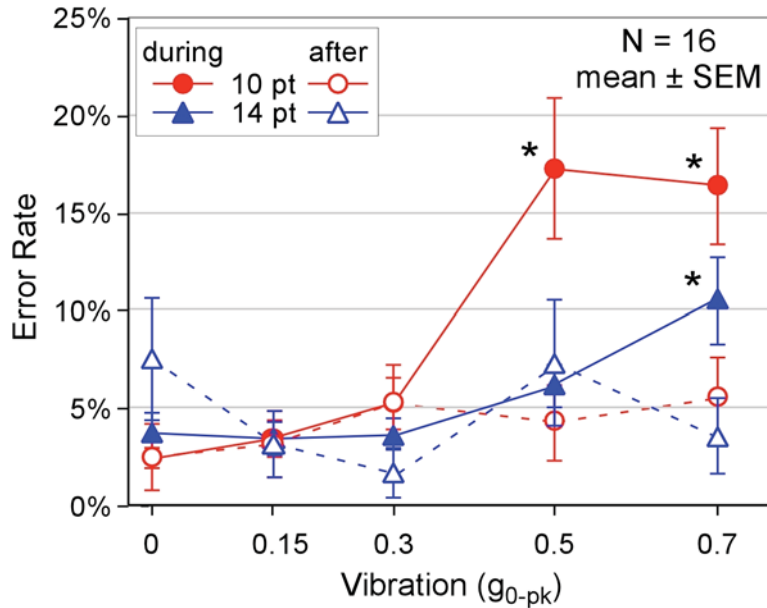

Figure 14. Mean error rates (\pm SEM) of the general-population participants during (solid symbols and lines) and immediately after (open symbols and dashed lines) vibration at each of the 5 levels for 10-pt (red) and 14-pt (blue) font. Note the three points with significant ($p < 0.05$) increases over baseline. Note also the fact that performance after vibration (dashed lines) is unchanged from that at the 0-g baseline.

4.5.2 Objective Performance Data: Effect of Target Location

Given that the vibration load in this study exceeded the capability of gaze stabilization reflexes to keep retinal images fully stationary on the retina and given that these vestibular reflexes are more compromised for eccentric gaze (see Introduction), we anticipated that there could be an effect of gaze angle (related to the visual angle of the target) on our performance metrics, RT and ER. However, because the target for each reading trial could appear at any of 36 locations, and typically only about 50 trials were completed during each vibration block, a particular grid location might only appear once or twice at a given vibration level and font size for each participant. Therefore, we needed to pool the data across participants and across certain conditions in order to provide sufficient statistical power.

To achieve this we categorized the target locations into three levels of eccentricity (Center, Middle, Maximum) as depicted in Figure 15. Each target was assigned an eccentricity value for both azimuth (horizontal direction) and elevation (vertical direction). The three levels of eccentricity were 2.2°, 6.6°, and 11.0°.

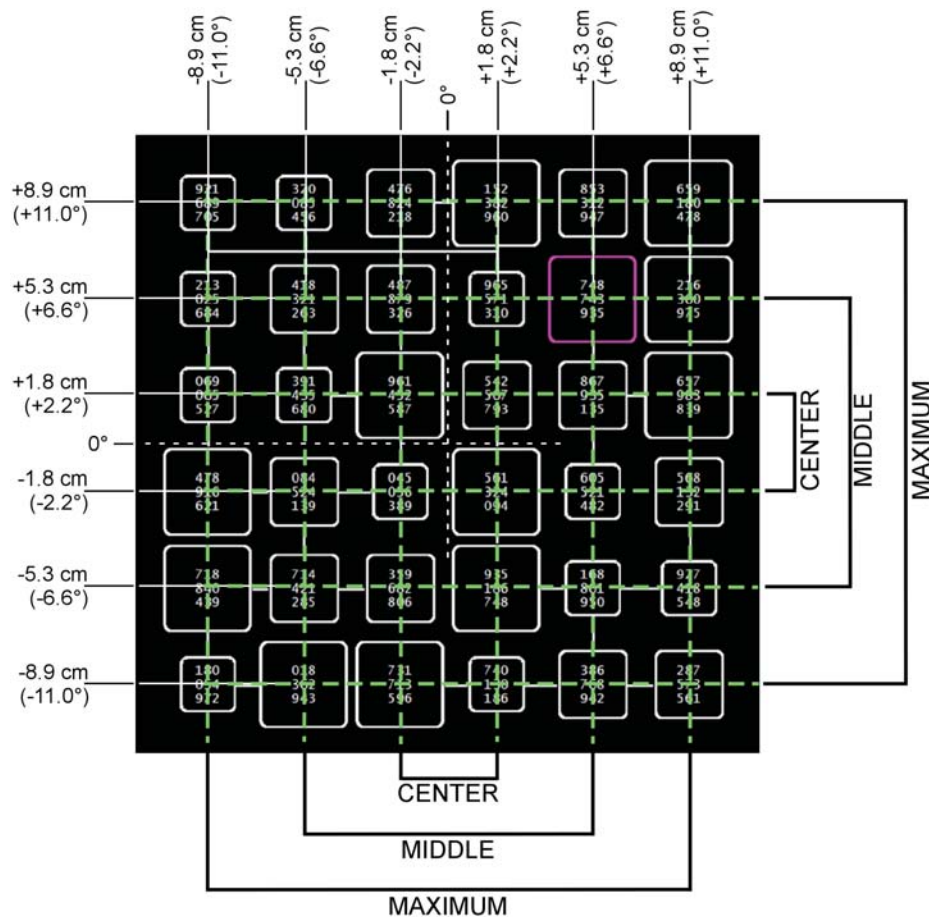

Figure 15. The folding technique used to form column and row groupings that define three levels of eccentricity in azimuth and elevation. Dimensions are shown in physical screen coordinates, but can also be expressed in terms of visual angle (2.2°, 6.6°, and 11.0°, respectively) for the nominal 46 cm viewing distance employed in the study.

We found clear effects of target location on both indices of performance. RT was longer (Figure 16) and ER higher (Figure 17) when the target was farther from the center of the display.

Four-way repeated measures ANOVAs of RT and ER using absolute azimuth (3 levels) and elevation (3 levels), plus font size (2 levels) and vibration amplitude classified into low (≤ 0.3 g) or high (≥ 0.5 g) (i.e., into 2 levels) were performed to assess the significance of these findings.

For RT, aside from the main effects of vibration and font size and the interaction between the two as reported above, we found significant main effects for azimuth ($F_{2,30} = 18.256, p < 0.0001$) and elevation ($F_{2,30} = 27.295, p < 0.0001$), but no significant interactions between azimuth and elevation, or between either of these and vibration level or font size. The effect of target azimuth on RT is evident in the left-hand panel of Figure 16 while that for target elevation is shown in the right-hand panel. Newman-Keuls post-hoc tests indicate RT is significantly longer for the more eccentric angles in both azimuth and elevation when compared with the 2.2° angle near the center of the display ($D_{\text{critical}} = 37$ ms and 31 ms, respectively, $p < 0.05$). Thus, regardless of vibration level, responses took longer when the target was farther from the center of the display with about a 100-ms penalty at 11.0° .

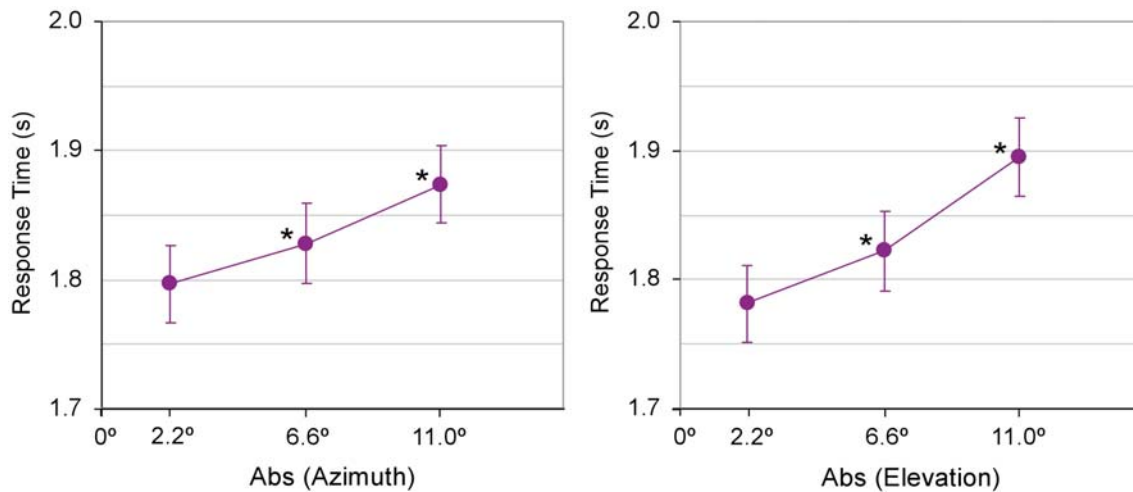

Figure 16. Effect of target location on response time. RT (\pm SEM) is plotted as a function of the absolute angular azimuth and elevation of the target location with respect to the center of the display. Note that at both 6.6° and 11.0° for both azimuth and elevation, there is a significant increase in RT over that for the center of the display.

For ER, again aside from the main vibration and font effects and vibration-font interaction reported above, the ANOVAs revealed significant main effect of elevation ($F_{2,30} = 4.514, p < 0.02$) but not of azimuth ($F_{2,30} = 0.938, p = 0.40$). The absence of any clear effect of azimuth on performance accuracy is evident in the left-hand panel of Figure 17 while a clear effect of elevation is apparent for the high-vibration curves in the right-hand panel. In fact, the ANOVA reveals a significant interaction between elevation and vibration level ($F_{2,30} = 5.981, p < 0.007$). Newman-Keuls post-hoc testing of ER for the high-vibration class (i.e., lumped 0.5 and 0.7 g data) show a significant increase between the smallest (2.2°) largest (11.0°) target angle ($D_{\text{critical}} = 3.34\%, p < 0.05$) with no effect of target elevation on ER for the low-vibration class (i.e., lumped 0, 0.15 and 0.3 g data). Thus, for the

two highest vibration levels, vertically offset viewing angles (but not horizontally offset angles) further compromise performance accuracy such that error rates are approximately 1.5 times greater for targets at an eccentricity of 11.0° . The lack of significant effect for the low vibration levels is not surprising given that the overall ER is so low for these conditions.

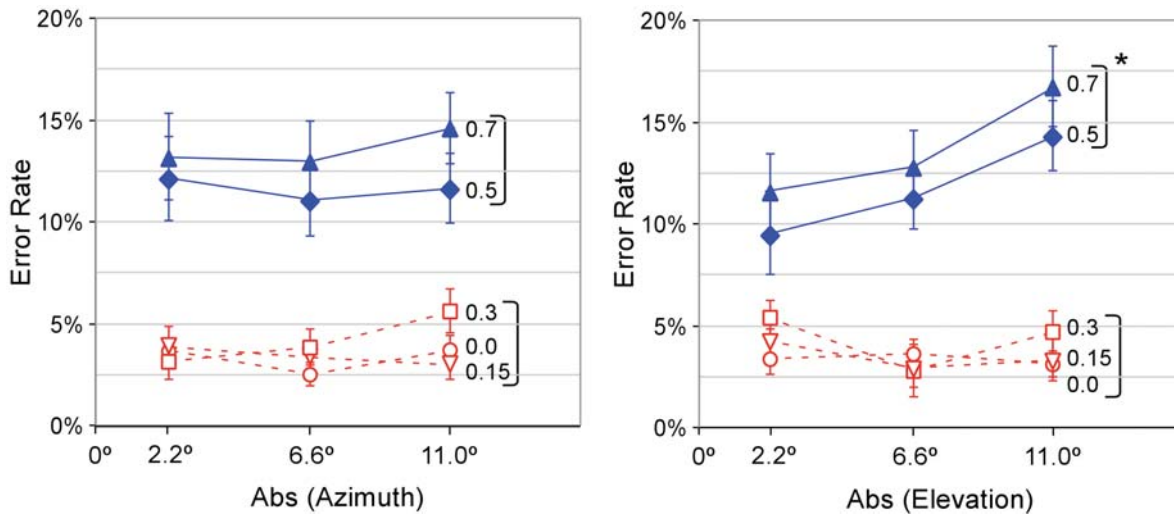

Figure 17. Effect of target location on error rate. ER (\pm SEM) is plotted as a function of the absolute angular azimuth and elevation of the target location with respect to the center of the display for each vibration level separately. Note the clear distinction that can be made between the high-vibration class (0.5 and 0.7 g – blue symbols and solid lines) and the low-vibration class (0, 0.15, 0.3 g – red symbols and dashed lines). Note also that there is no significant effect of azimuth on ER for either class (left-hand panel) while there is a significant effect ($p < 0.05$) at the 11.0° elevation for the high-vibration class (right-hand panel).

4.5.3 Subjective Rating Data: Effect of Vibration Level and Font Size

Following each block of trials participants were required to use seven-point Likert rating scales to respond to three questions regarding: 1) the legibility of the numeric text displays; 2) the difficulty of the number processing task; and 3) the degree of attentional effort required to perform the task. Each individual's ratings from 1 to 7 (according to the scales in Table 1) for the 10 blocks (5 vibration levels X 2 font sizes) were converted to ranks ranging from 1 to 10 (best-to-worst for legibility; lowest-to-highest for difficulty and effort). Identical ratings were adjusted for ties such that the sum of an individual participant's 10 rankings for a particular Likert question always totaled 55. The general population group's median Likert ranks are plotted in the three panels of Figure 18.

The general population Likert rankings showed a monotonic increase over the range of vibration levels tested and a clear difference for the two font sizes. Non-parametric Wilcoxon-Wilcox multiple comparisons (Sachs, 1984) of the Likert ranks were performed to evaluate the significance of these results (see asterisks in Figure 18). For the 10-pt font, for all three Likert questions this analysis showed that the subjective rankings were significantly higher (i.e., worse) than those for the 0-g baseline at the 0.5 and 0.7 g levels. For the 14-pt font the median Legibility rankings were

significantly above the baseline at both the 0.5 and 0.7 g levels. The median Task Difficulty and Attentional Effort rankings, however, were significantly above baseline only for the 0.7 g level.

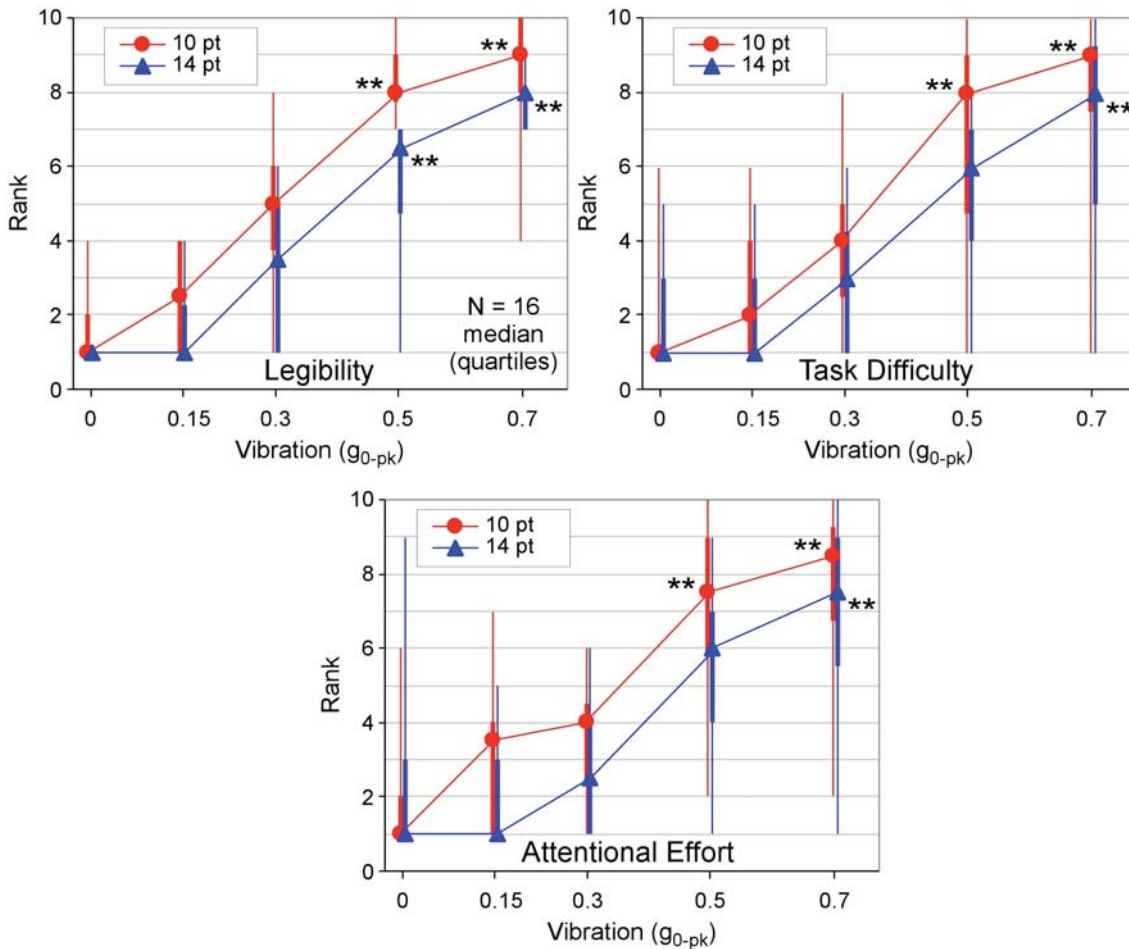

Figure 18. Median (\pm inter-quartiles and max/min) of the Likert rankings of the 16 general-population participants as a function of vibration level. Lower rankings indicate better subjective ratings for legibility and lower ratings difficulty and effort. Double asterisks indicate significance at the $p < 0.01$ level (Wilcoxon-Wilcox multiple comparisons).

4.5.4 Relationship between Object Performance and Subjective Rating Data

Inspection of the plotted medians of the subjective Likert rankings for the general population participants (Figure 18) reveals an overall sensitivity to vibration level and font size which appears similar to that for mean objective ER and RT measures (Figures 11 and 12). This overall pattern of agreement between the objective and subjective performance measures across participants prompted us to examine within-participant correlations. The intersection of the rows and columns in Table 2 shows all of the possible pair-wise combinations of the three subjective with the two objective measures. For each pair-wise combination we counted the number of participants (out of the 16 total) who showed a significant ($p < 0.05$) Spearman rank correlation between the paired measures.

Interestingly, the Legibility ranking appears to correlate most frequently with RT and the Effort ranking most frequently with ER.

TABLE 2. COUNT AND PROPORTION (%) OF SIGNIFICANT CORRELATIONS

	<i>Legibility</i>	<i>Difficulty</i>	<i>Effort</i>
Response Time	13 (81%)	8 (50%)	7 (44%)
Error Rate	9 (56%)	10 (63%)	11 (69%)

The probability of the count of significant within-participant correlations reported in any one cell of Table 2 can be computed using the binomial distribution, $P_{n,p}(k)$, where $n = 16$ (total number of participants), $p = 1/20$ (probability that an individual participant's observation is significant at $p = 0.05$ or better), and k is the number of counts in that cell. Thus for any individual cell in Table 2, the number of counts, $k \geq 7$, has a probability of $P_{16,0.05}(k) < 0.00001$. Consequently, we can conclude that the proportion of significant ($p < 0.05$) within-participant correlations between objective and subjective measures is highly significant across participants and therefore objective reading performance effects may be largely predictable from the subjective rankings (and vice versa).

5.0 Experiment 1B: Crew Office Population

The purpose of Experiment 1B was to compare the performance of an operationally trained and more experienced population to that of the general population participants and to determine if there were any significant performance differences. To that end, participants were recruited from the Astronaut Crew Office at Johnson Space Center (JSC). The solicitation for participation was extended to active members of the Astronauts Corps (both pilots and mission specialists) and to Army pilots detailed to the office.

5.1 Method

5.1.1 Participants

Following a briefing that outlined the study's goals and participants' commitments and risks, thirteen members (10 men and 3 women) of the JSC Astronaut Office agreed to participate in this study. During the centrifuge sessions a JSC flight surgeon monitored participants' well being via closed-circuit video cameras, voice communications, and blood oxygen saturation data. Any additional medical data collection was performed at the discretion of the flight surgeon and crew office participant. (The flight surgeon was also on-call for the fixed-base sessions.) None of the participants elected to terminate any of their familiarization or test sessions nor were any sessions terminated for medical cause.

5.1.2 Stimuli and Procedures

The stimuli used in Experiment 1B were identical to those used in Experiment 1A. Experiment 1B's procedures were the same as Experiment 1A with the following exceptions:

- In the fixed-based phase of the study, participants' heads were not strapped down during the reading-task training and baseline data collection blocks, unlike in Experiment 1A. These blocks were part of a single session that included training and data collection for a separate display usability study. (This display usability study will be discussed in a separate report.) Because the usability study involved periods of exposure to vibration and participants' heads were strapped to the platform during those periods, keeping their heads strapped down for both that study and the number-reading task blocks was deemed excessive.
- Unlike the general population participants in Experiment 1A, crew office participants completed only one reading-task test session in the centrifuge facility (i.e., half the number of data collection blocks completed by the general population participants). To accommodate this smaller block number, font size was changed to a between-participant factor, with six participants receiving the small-font stimuli and seven experiencing the large-font stimuli.
- In Experiment 1A, the temporal separation between the fixed-based familiarization and training session and 20-G centrifuge familiarization session was variable; in Experiment 1B, all training and familiarization sessions were completed in a single day. Further, the crew office participants in Experiment 1B completed the centrifuge testing session the day after their training and familiarization sessions; this delay was much longer for the general population participants (i.e., 2-12 days between their centrifuge familiarization and their first testing session).
- Because of their prior experience in hyper-G environments, crew office participants ran an abbreviated version of the G-load only familiarization run. Generally, participants were ramped to a brief exposure of 1.5 G; upon confirming that they were comfortable to proceed, participants were then ramped to 3.0 G, maintained that for 30-45 s, and then ramped to 3.8 G. After maintaining 3.8 G for 60-90 s, participants were ramped down to 1.5 G, held for 20-30 s, then were ramped down to a full stop.
- During their familiarization sessions crew office participants completed an additional 3.8 G cycle (with time-varying vibration amplitude) to prepare for their participation in a separate display-rating study. Given their abbreviated G-load only run, crew office participants' centrifuge familiarization sessions were about the same length as the general population participants.
- The padding on the fixed-base platform chair was removed and replaced with sheet metal and thin foam similar to that on the centrifuge. This was done to ensure commonality in vibration transmission, primarily for a separate display-rate task that only the crew office participants completed.

5.2 Results

5.2.1 Objective Performance Data: Effect of Vibration Level and Font Size

The mean (\pm SEM) RT and ER for the 13 crew office participants ($N = 7$ for the 10-pt and $N = 6$ for the 14-pt font) are provided in Figures 19 and 20, respectively. Note that the effects of vibration on crew RT and ER are qualitatively similar to those found in the general-population data (compare Figures 19 and 20 with Figures 11 and 12). Note also that, as with the general population, there is no discernible after-effect of vibration on crew performance.

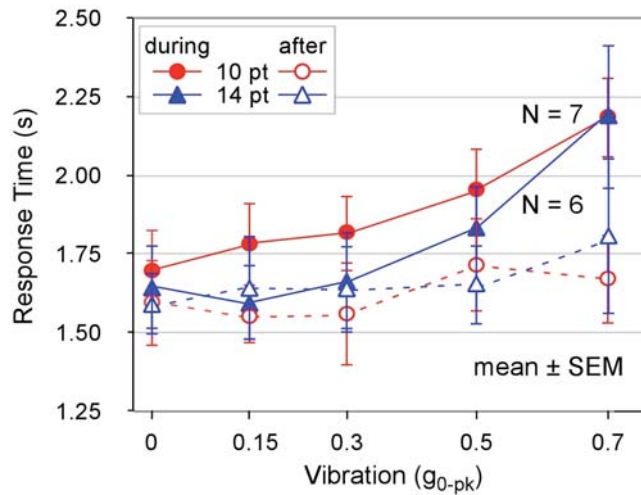

Figure 19. Mean response times (\pm SEM) of the crew office participants during (solid symbols and lines) and after (open symbols and dashed lines) vibration at each of the 5 levels for the 10-pt font group (red) and the 14-pt font group (blue). Performance immediately after vibration stopped appears unchanged from that at the 0-g baseline (dashed lines). Note the qualitative similarity of these results with those shown in Figure 11.

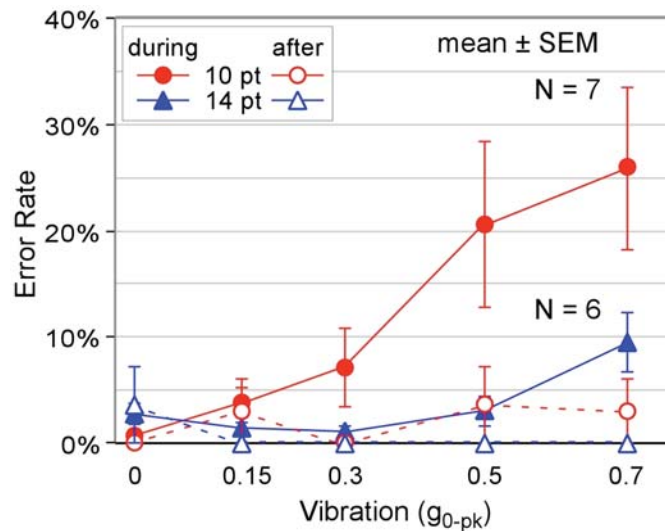

Figure 20. Mean error rates (\pm SEM) of the crew office participants during (solid symbols and lines) and after (open symbols and dashed lines) vibration at each of the 5 levels for the 10-pt font group (red) and the 14-pt font group (blue). Performance immediately after vibration appears unchanged from that at the 0-g baseline (dashed lines). Note the qualitative similarity with the data shown in Figure 12.

(NOTE: One participant in the 10-pt font group self-reported being unable to read the numbers during the 0.5 and 0.7 g conditions and resorting to random response button pressing. Subsequent analysis indicated the individual's error rate was at chance levels for those two blocks and response

time was shorter rather than longer (consistent with random button pressing) contrary to the trend for the remaining crew and general-population participants. The data from this participant were nonetheless included in the figures and analyses as their inclusion did not alter any of the trends or statistics. However, their inclusion may have slightly biased the mean RT downward and mean ER upward for the 10-pt data.)

To assess rigorously whether there were significant quantitative differences between our crew office and general-population groups, between-group ANOVAs on RT and ER were performed separately for each font size (see Figure 21 for RT, Figure 22 for ER). The ANOVAs demonstrated significant main effects for vibration in all four cases as expected (RT 10-pt: $F_{4,84} = 21.802, p < 0.0001$; RT 14-pt: $F_{4,80} = 21.932, p < 0.0001$; ER 10-pt: $F_{4,84} = 21.794, p < 0.0001$; RT 14-pt: $F_{4,80} = 9.765, p < 0.0001$) but showed no significant differences between the general and crew office populations. Thus, we found no meaningful distinction between the general and crew office populations in their reading performance.

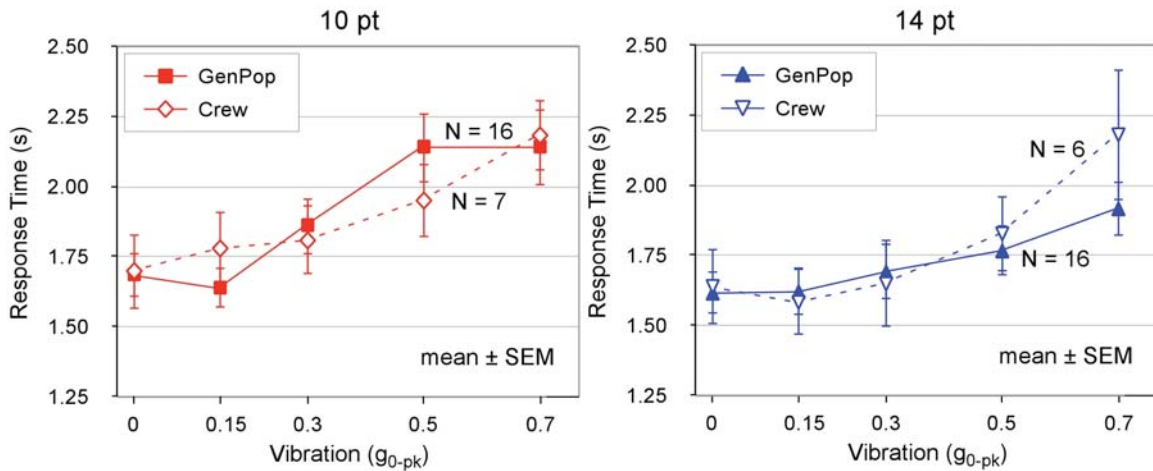

Figure 21. Mean Response Time (\pm SEM) of the general (solid symbols and lines) and crew office (open symbols and dashed lines) populations during vibration at each of the 5 levels for 10-pt font (red) and 14-pt font (blue).

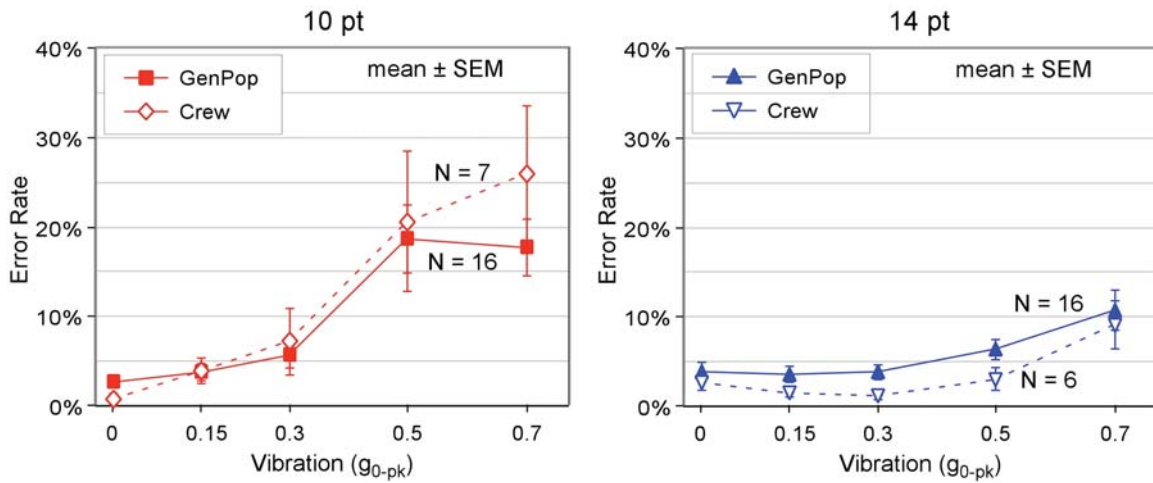

Figure 22. Mean Error Rate (\pm SEM) of the general (solid symbols and lines) and crew office (open symbols and dashed lines) populations during vibration at each of the 5 levels for 10-pt font (red) and 14-pt font (blue).

5.2.2 Subjective Rating Data: Effect of Vibration Level and Font Size

Crew office participants also responded to the three Likert rating questions on legibility, task difficulty, and attentional effort after each block. These participants performed only five blocks (5 vibration levels X 1 font). Consequently, an individual's ratings were converted into rankings from 1 to 5. Because the two font sizes were assigned to separate crew office groups (unlike the general-population data), Likert ranks for the two font sizes cannot be directly compared and are therefore plotted separately in Figures 23 and 24.

Consistent with the general-population participants, the crew office participants' Likert rankings showed a monotonic increase over the range of vibration levels tested for both font groups. Because of the small sample size and the smaller range of rankings (5 instead of 10) across-participant statistical analyses did not have sufficient power and were therefore of minimal value. Although many points approached significance, only three points reached significance ($p < 0.05$): the median Legibility and Difficulty rankings at 0.7 g and the median Legibility ranking at 0.5 g.

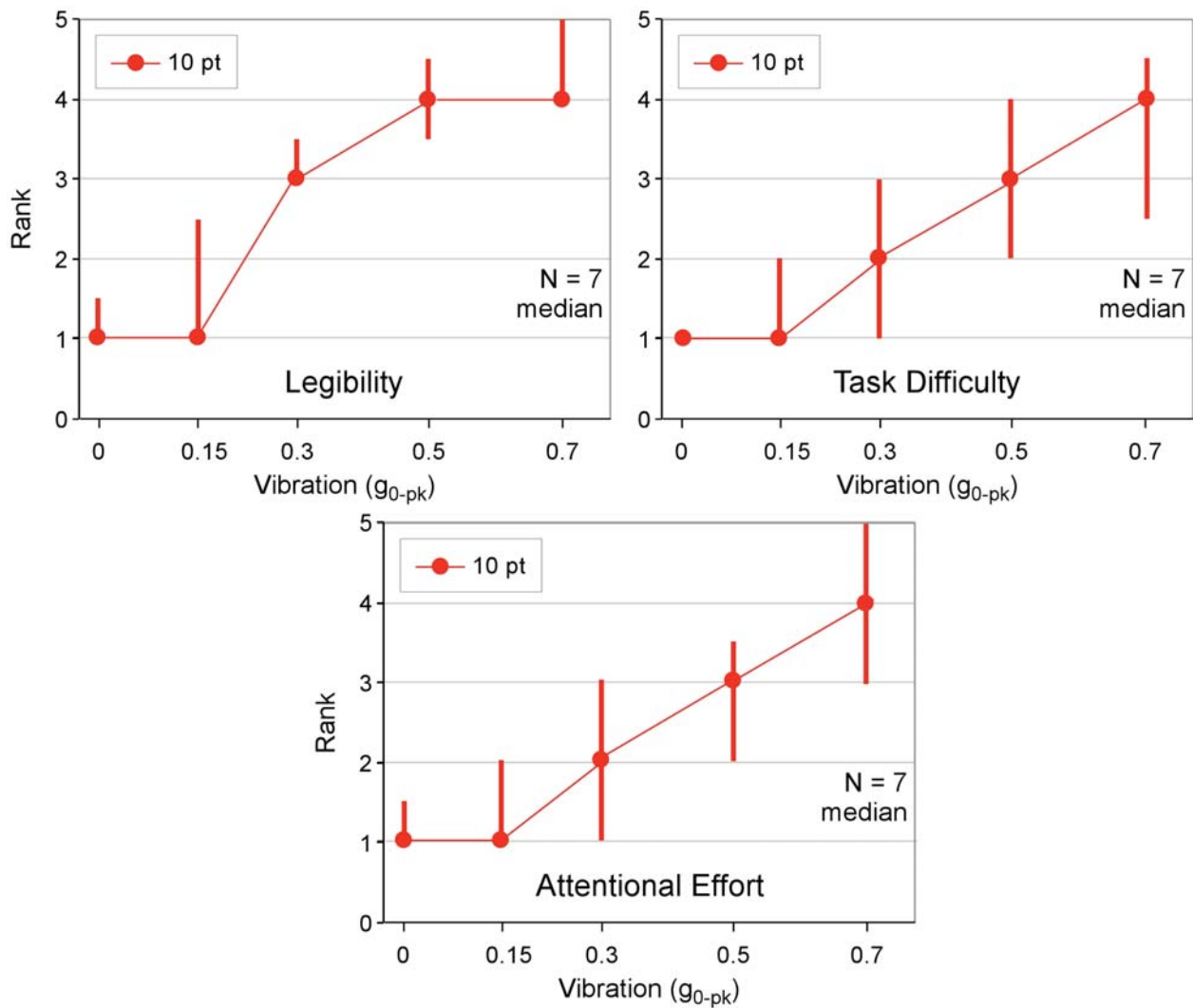

Figure 23. Crew office participants' median Likert rankings (\pm inter-quartiles) for the 10-point-font number-reading task. Lower rankings indicate better subjective ratings for legibility and lower ratings difficulty and effort. (Note that the apparent absence of some inter-quartile bars is due to the quartile being equal to its median.)

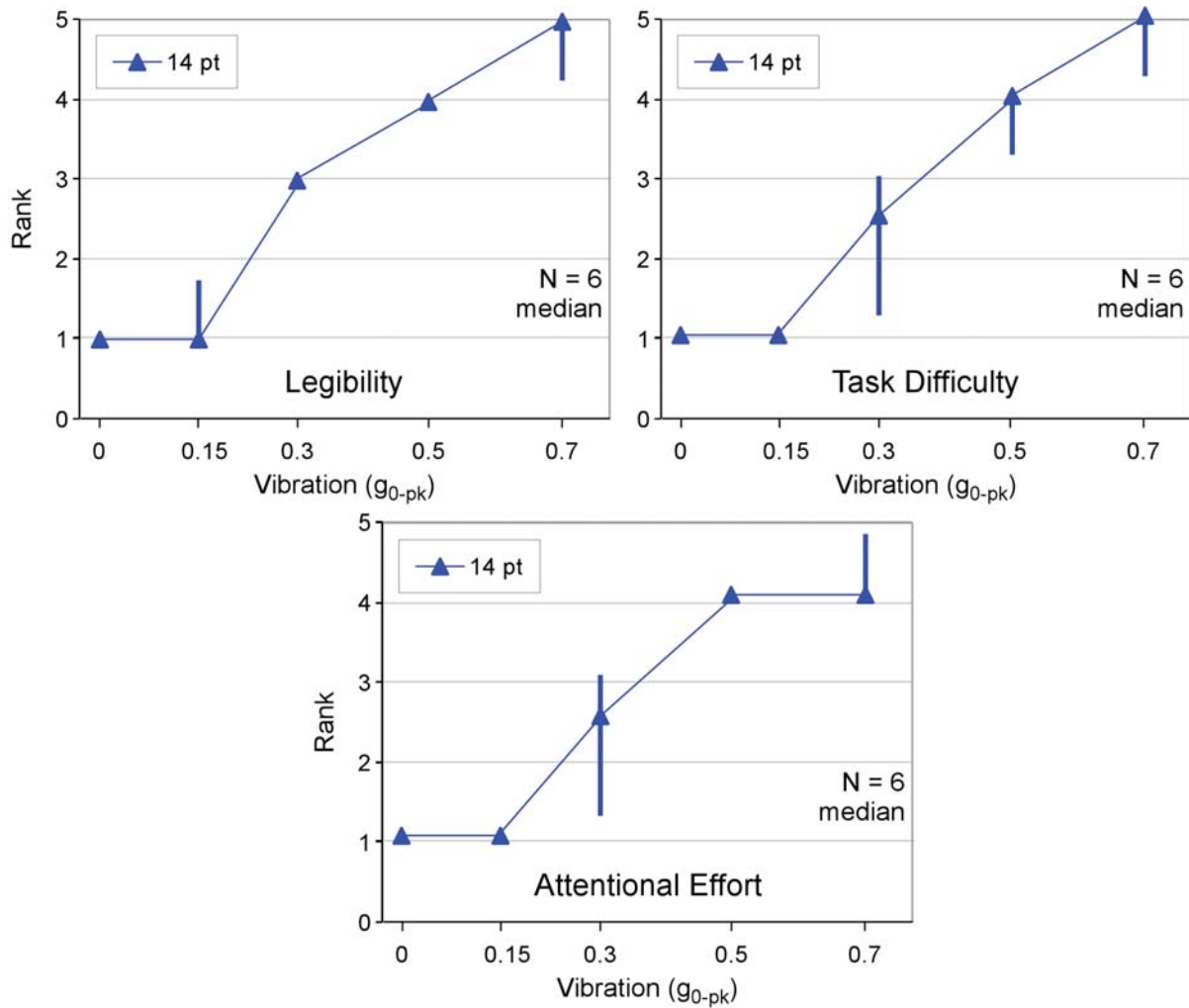

Figure 24. Crew office participants' median Likert rankings (\pm inter-quartiles) for the 14-pt-font number-reading task. Lower rankings indicate better subjective ratings for legibility and lower ratings difficulty and effort. (Note that the apparent absence of some inter-quartile bars is due to the quartile being equal to its median.)

6.0 Conclusions

There is a highly significant effect on reading performance of combined sustained Gx loading (3.8 G) plus 12 Hz x-axis vibration within the 0 to 0.7 g range tested, including:

- Up to a 7-fold increase in reading errors under some conditions
- Up to a 450-ms increase in response time under some conditions
- A significant decrease in subjectively reported legibility
- A significant increase in subjectively reported difficulty
- A significant increase in subjectively reported effort
- Considerable inter-subject variability, with some participants able to maintain near-perfect performance even at the highest vibration level, while others perform at or near chance

The source of variability could be due to a number of factors, including: individual differences in participants' biomechanical responses (e.g., neck and torso articulation, neck and head position relative to the head rest and seat back, aspects of head restraint, and head motion); neurovestibular factors (i.e., how well the Vestibulo-Ocular Reflexes stabilized images on the retina); or cognitive or autonomic factors (e.g., how well the participant could ignore the stressor). Future studies and analyses will need to examine the source(s) of this inter-subject variability more closely.

Not surprisingly, the performance impact of Gx loading plus vibration depends on font size. Specially, we found that compared to the no vibration baseline condition:

- For 10-pt-font displays, performance was not significantly impacted at the 0.3-g vibration level but was significantly slower and less accurate beginning at 0.5 g.
- For 14-pt-font displays, performance was not significantly impacted at the 0.5 g vibration level but was significantly slower and less accurate at 0.7 g.

These data show that, for the levels tested (0.15 g, 0.3 g, 0.5 g, and 0.7 g), the current font specifications for the Orion display may not support effective reading during 12 Hz vibration at and above 0.5 g. Thus, without some mitigation it is reasonable to assume that system-monitoring tasks will likely be adversely impacted under such conditions. We will address this further in a companion study of experts' display-usability ratings under Gx-loading plus vibration conditions. The significant font-size effect strongly suggests that the performance impacts of Gx-loading plus vibration on reading can be, at least to a large degree, mitigated by increasing font size, spacing text less closely together, and, in general, by reducing display clutter. A future parametric study will be needed to determine the limitations of this trade space.

Furthermore, the performance impact of vibration depends on target eccentricity. Specifically, we found that:

- For targets 11° above or below the display center, error rates increased by a factor of 1.5 compared to the close-in (2.2° eccentric) targets but only when vibration levels were at or above 0.5 g.
- For targets 6.6° away from the display center (both vertical and horizontal), responses took about 30 ms longer than for the close-in (2.2° eccentric) targets, independent of vibration level.

- For targets 11° away from the display center (both vertical and horizontal), responses took about 100 ms longer than for the close-in targets, independent of vibration level.

The response time (RT) data and its independence of vibration level are consistent with visual search performance within a cluttered display being serial and with peripheral vision being less effective for color discrimination (and thus may not be due to the Gx loading). This non-vibration effect could be mitigated using brighter and more color-saturated alerts within less cluttered and more central displays so as to allow for more effective attentional capture in the periphery. Future comparison with RT data using identical tasks and displays at 1 G will be needed to determine whether or not Gx was an exacerbating factor.

The error rate (ER) data and its dependence on vibration level are consistent with compromised gaze stabilization reflexes during high-frequency, high-amplitude vibration. The specificity of the impairment to the vertical axis is consistent with post-experiment debrief comments that vibration preferentially caused confusion between vertically adjacent lines (as opposed to horizontally adjacent letters) and with the recorded video evidence that our x-axis vibration induced not only fore-aft head motion but also because of human neck biomechanics, head pitching and as well as front-back x-axis motion. These vertically directed head movements undoubtedly contributed to the gaze stabilization problem and are likely the dominant source of the increased ER for vertical offsets from the center of the display. Mitigation strategies include increasing the viewing distance and keeping critical information close to the display center in order to reduce the demand on the Vestibular Ocular Reflexes (VORs). Future studies and analyses will be needed to determine the correlation between performance and these multi-dimensional head-motion factors to tease apart the gx and gz, vibration and rotational components (and/or other components) of the effect.

Somewhat surprisingly, we found no evidence for an aftereffect on reading performance at any the vibration levels tested. Specifically, we found that both error rate and response time in our reading task were indistinguishable prior to and immediately following vibration.

Given the fact that for some participants there was considerable ataxia as well as perceptual illusions lasting for the better part of an hour after an experimental session, it is clear that there are indeed after-effects to exposure to our altered gravito-inertial conditions, especially during head movements. Future studies will be needed to quantify these sensorimotor effects and to tease apart those effects likely due to Gx loading (either in isolation or in combination with vibration) from those likely due to the rotational artifacts of centrifugation.

We found no meaningful distinction in reading performance between crew-office personnel and age-matched general population participants. Specifically, we found that:

- There was qualitative agreement between all of the data trends for both the objective and subjective measures of performance.
- The error rates and response times of the general and crew-office populations were statistically indistinguishable.

In the future, it would seem appropriate to use crew-office “expert” participants only in those studies that require such expertise (e.g., Cooper-Harper-like usability ratings, manual control) and to rely on age-matched general population participants when measuring basic human perceptual or motor responses or gross cognitive function.

Caution should be used in interpreting these results. They represent a trade space for performance on a relatively simple number reading task with static displays. Major unknowns that merit further examination include:

- Performance effects of vibration for higher-fidelity dynamic displays and complex flight-like tasks
- Effects of vibration on performance in manual control tasks
- Effects of suit-seat-helmet interactions with each other and with vibration—these may amplify or damp vibration and head-helmet-seat interactions could produce off-axis head translations and rotations.
- Performance effects of seat off-axis vibration (y- and z-axes) and combinations of multiple axis vibration
- Relationship of performance impacts to actual head-motion (as opposed to seat motion) with particular emphasis on any cross-coupled z-axis translation and pitch (rotation about the y-axis) responses in order to better understand the inter-subject variability and to better characterize the gaze-angle dependence of reading performance under vibration
- Effect of independent display vibration, especially given the fact that, at the TO frequency, visual gaze-stabilization mechanisms will be completely ineffective and vestibular gaze-stabilization mechanisms will be working to stabilize the eyes with respect to an assumed stationary display.

7.0 References

- Adelstein, B.; Beutter, B.; Kaiser, M.; McCann, R.; Stone, L.; and Anderson, M. (2009). *Effects of Transverse Seat Vibration on Near-Viewing Readability of Alphanumeric Symbolology*. NASA/TM—2009-215385. NASA Ames Research Center, Moffett Field, Calif.
- Angelaki, D.E. (1998). Three-dimensional organization of otolith-ocular reflexes in Rhesus monkeys. III. Responses to translation. *Journal of Neurophysiology* 80: pp 680–695.
- Campbell, J.I.D.; & Epp, L.J. (2004). An encoding-complex approach to numerical cognition in Chinese-English bilinguals. *Canadian Journal of Experimental Psychology*, 58, pp 229–244.
- Canfield, A.A.; Comrey, A.L.; & Wilson, R.C. (1949). A study of reaction time to light and sound as related to positive radial acceleration. *Journal of Aviation Medicine* 20: pp 350.
- Chambers, R. (1961). *Control performance under acceleration with side-arm attitude controllers*. NADC-MA-6110. Johnsville, Pennsylvania: Naval Air Development Center.
- Chambers, R. & Hitchcock, L. (1962). Effects of high G conditions on pilot performance. In *Institute of the Aerospace Sciences, Proceedings of the national meeting of manned space flight*. New York.

- Chambers, R. & Hitchcock, L. (1963). *Effects of acceleration on pilot performance*. NADC-MA-6219. Johnsville, Pennsylvania: Naval Air Development Center.
- Chambers, R.M. & Nelson, J.G. (1961). Pilot performance capabilities during centrifuge simulations of boost and reentry. *American Rocket Society Journal*, 31, pp 1534–1541.
- Clarke, N.; Hyde, A.; Cherniack, N.; & Lindberg, E. (1959). *A preliminary report of human response to rearward-facing re-entry accelerations*. WADC-TN-59-109. Wright-Patterson AFB, Ohio: Wright Air Development Center.
- Clarke, N.P.; Taub, H.; Scherer, H.F.; Temple, W.E.; Vykukal, H.C.; & Matter, M. (1965). *Preliminary study of dial reading performance during sustained acceleration and vibration*. Technical Report AMRL-TR-65-110. Wright-Patterson AFB, Ohio: Aerospace Medical Research Laboratories.
- Cochran, L.; Gard, P.; & Norsworthy, M. (1954). *Variation in human G tolerance to positive acceleration*. Pensacola, Florida: Naval School of Aviation Medicine.
- Cohen, M.M. (1970a). Sensory-motor adaptation and aftereffects of exposure to increased gravitational forces. *Aerospace Medicine*, 41, pp 318–322.
- Cohen, M.M. (1970b). Hand-eye coordination in altered gravitational fields. *Aerospace Medicine*, 41, pp 647–649.
- Fabignon, Y.; Dupays, J.; Avalon, G.; Vuillot, F.; Lupoglazoff, N.; Casalis, G.; & Prévost, M. (2003). Instabilities and pressure oscillations in solid rocket motors. *Aerospace Science and Technology*, 7(3), pp 191–200.
- Goldreich, D.; Krauzlis, R.J.; & Lisberger, S.G. (1992). Effect of changing feedback delay on spontaneous oscillations in smooth pursuit eye movements of monkeys. *Journal of Neurophysiology*, 67(3), pp 625–3.
- Grimwood, J.M.; Hacker, B.C.; & Vorzimmer, J. (1969). "Project Gemini Technology and Operations." NASA SP-4002, pp 68.
- Himmelblau, H.; Fuller, C.M.; & Scharton, T.D. (1970). *Assessment of Space Vehicle Aeroacoustic-vibration Prediction, Design, and Testing*. NASA Contractor Report CR-1596. Washington, D.C.: National Aeronautics and Space Administration.
- Howard, I.P. (1982). *Human Visual Orientation*. New York: Wiley, pp 30.
- International Organization for Standardization (1997) *ISO 2631/1-1997. Evaluation of human exposure to whole-body vibration. Part 1: general requirements*. Geneva, Switzerland: International Organization for Standardization.

- Kaehler, R. & Meehan, J. (1960). *Human psychomotor performance under varied transverse accelerations*. WADD-TR-60-621. Wright-Patterson AFB, Ohio: Wright Air Development Division.
- McHenry, M.Q. & Angelaki, D.E. (2000). Primate translational vestibuloocular reflexes. II. Version and vergence responses to fore-aft motion. *Journal of Neurophysiology* 83: pp 1648–1661.
- O'Briant, C.R. & Ohlbaum, M.K. (1970). Visual acuity decrements associated with whole body plus or minus Gz vibration stress. *Aerospace medicine*, 41(1), pp 79–82.
- O'Hanlon, J. & Griffin, M. (1971). *Some effects of the vibration of reading material upon visual performance*. Southampton, U.K.: ISVR Technical Report No. 49, University of Southampton.
- Paige, G.D. & Tomko, D.L. (1991). Eye movement responses to linear head motion in the squirrel monkey. II. Visual-vestibular interactions and kinematic considerations. *Journal of Neurophysiology* 65: pp 1183–1196.
- Prévost, M. ; LeQuellec, A. & Godon, J.C. (2006). Thrust oscillations in reduced scale solid rocket motors, a new configuration for the MPS of Ariane 5. *Proceedings of 42nd AIAA/ASME/SAE/ASEE Joint Propulsion Conference & Exhibit*. 9-12 July, Sacramento, California.
- Ramachandran, R. & Lisberger, S.G. (2005). Normal performance and expression of learning in the vestibulo-ocular reflex (VOR) at high frequencies. *Journal of Neurophysiology*, 93(4), pp 2028–38.
- Sachs, L. (1984). *Applied Statistics: A Handbook of Techniques*. New York: Springer-Verlag, pp 555–558.
- Schafer, L.E. & Bagian, J.P. (1993). Overhead and forward reach capability during exposure to +1 to +6 Gx loads. *Aviation, space, and environmental medicine*, 64(11), pp 979–84.
- Temple, W.E.; Clarke, N.P.; Brinkley, J.W.; & Mandel, M.J. (1964). Man's short-time tolerance to sinusoidal vibration. *Aerospace Medicine*, 35(10), pp 923–930.
- Tychsen L. & Lisberger SG. (1986). Visual motion processing for the initiation of smooth-pursuit eye movements in humans. *Journal of Neurophysiology*, 56(4), pp 953–68.
- Vogt, H.L.; Krause, H.E.; Hohlweck, H.; & May, E. (1973). Mechanical impedance of supine humans under sustained acceleration. *Aerospace Medicine*, 44, pp 675–679.
- Vykukal, H.C. (1968). Dynamic response of the human body to combined vibration when combined with various magnitudes of linear acceleration. *Aerospace Medicine*, 39, pp 1163–1166.
- Vykukal, H.C. & Dolkas, C.B (1966). Effects of combined linear and vibratory accelerations on human body dynamics and pilot performance capabilities. Presented to the 117th

International Aeronautical Congress, Madrid, Spain, October 9-15.

White, W. & Jorve, W. (1956). *The Effects of Gravitational Stress upon Visual Acuity*. WADC-TR-56-247. Wright-Patterson AFB, Ohio: Wright Air Development Center.

Williams, E.J. (1949). Experimental designs balanced for the estimation of residual effects of treatments. *Australian Journal of Scientific Research, Ser. A 2*, pp 149–168.

Zarriello, J., Norsworthy, M., & Bower, H. (1958). *A study of early grayout threshold as an indicator of human tolerance to positive radial acceleratory force*. Project NM 11-01-11, Subtask 1, Report No. 1. Pensacola, Florida: Naval School of Aviation Medicine.

Report Documentation Page

Form Approved
OMB No. 0704-0188

The public reporting burden for this collection of information is estimated to average 1 hour per response, including the time for reviewing instructions, searching existing data sources, gathering and maintaining the data needed, and completing and reviewing the collection of information. Send comments regarding this burden estimate or any other aspect of this collection of information, including suggestions for reducing this burden, to Department of Defense, Washington Headquarters Services, Directorate for Information Operations and Reports (0704-0188), 1215 Jefferson Davis Highway, Suite 1204, Arlington, VA 22202-4302. Respondents should be aware that notwithstanding any other provision of law, no person shall be subject to any penalty for failing to comply with a collection of information if it does not display a currently valid OMB control number.
PLEASE DO NOT RETURN YOUR FORM TO THE ABOVE ADDRESS.

1. REPORT DATE (DD-MM-YY) 01-05-2009		2. REPORT TYPE Technical Memorandum		3. DATES COVERED (From – To)	
4. TITLE AND SUBTITLE Influence of Combined Whole-Body Vibration Plus G-Loading on Visual Performance				5a. CONTRACT NUMBER _____ 5b. GRANT NUMBER _____ 5c. PROGRAM ELEMENT NUMBER _____	
6. AUTHOR(S) Bernard D. Adelstein, Brent R. Beutter, Mary K. Kaiser, Robert S. McCann, Leland S. Stone, Mark R. Anderson, Fritz Renema, and William H. Paloski				5d. PROJECT NUMBER _____ 5e. TASK NUMBER _____ 5f. WORK UNIT NUMBER 466-199	
7. PERFORMING ORGANIZATION NAME(S) AND ADDRESSES(ES) NASA Ames Research Center Moffett Field, California 94035-1000				8. PERFORMING ORGANIZATION REPORT NUMBER TH-079	
9. SPONSORING/MONITORING AGENCY NAME(S) AND ADDRESS(ES) National Aeronautics and Space Administration Washington, DC 20546-0001				10. SPONSORING/MONITOR'S ACRONYM(S) NASA _____ 11. SPONSORING/MONITORING REPORT NUMBER NASA/TM—2009–215386	
12. DISTRIBUTION/AVAILABILITY STATEMENT Unclassified—Unlimited Subject Category: 53 Availability: NASA CASI (301) 621-0390 Distribution: Nonstandard					
13. SUPPLEMENTARY NOTES					
14. ABSTRACT In this study, we examined display readability—a fundamental prerequisite for any interaction with electronic crew-vehicle interfaces—while observers were subjected to 12 Hz vibration superimposed on the 3.8 G loading expected for the Ares thrust-oscillation period of ascent. Two age-matched groups of participants (16 general population and 13 Crew Office) performed a numerical display reading task while undergoing sustained 3.8 G loading and whole-body vibration. The time-constrained reading task used an Orion-like display. Compared to the no-vibration baseline, both groups demonstrated significant degradations in both ER and RT at 0.5 and 0.7 g for 10-pt, and at 0.7 g for 14-pt font displays. These objective performance measures were mirrored by participants' subjective ratings. No significant ER or RT aftereffects were detected immediately following vibration, regardless of amplitude.					
15. SUBJECT TERMS Vibration; G-loading; Readability; Crew performance; Launch environment					
16. SECURITY CLASSIFICATION OF:			17. LIMITATION OF ABSTRACT UU	18. NUMBER OF PAGES 48	19a. NAME OF RESPONSIBLE PERSON Bernard Adelstein
a. REPORT U	b. ABSTRACT U	c. THIS PAGE U			19b. TELEPHONE NUMBER (Include area code) (650) 604-3922

