



Procedure for Determining Turbulence Length Scales Using Hotwire Anemometry

Lamyaa A. El-Gabry
The American University in Cairo, New Cairo, Egypt

Douglas R. Thurman
U.S. Army Research Laboratory, Glenn Research Center, Cleveland, Ohio

Philip E. Poinsatte
Glenn Research Center, Cleveland, Ohio

NASA STI Program . . . in Profile

Since its founding, NASA has been dedicated to the advancement of aeronautics and space science. The NASA Scientific and Technical Information (STI) program plays a key part in helping NASA maintain this important role.

The NASA STI Program operates under the auspices of the Agency Chief Information Officer. It collects, organizes, provides for archiving, and disseminates NASA's STI. The NASA STI program provides access to the NASA Aeronautics and Space Database and its public interface, the NASA Technical Reports Server, thus providing one of the largest collections of aeronautical and space science STI in the world. Results are published in both non-NASA channels and by NASA in the NASA STI Report Series, which includes the following report types:

- **TECHNICAL PUBLICATION.** Reports of completed research or a major significant phase of research that present the results of NASA programs and include extensive data or theoretical analysis. Includes compilations of significant scientific and technical data and information deemed to be of continuing reference value. NASA counterpart of peer-reviewed formal professional papers but has less stringent limitations on manuscript length and extent of graphic presentations.
- **TECHNICAL MEMORANDUM.** Scientific and technical findings that are preliminary or of specialized interest, e.g., quick release reports, working papers, and bibliographies that contain minimal annotation. Does not contain extensive analysis.
- **CONTRACTOR REPORT.** Scientific and technical findings by NASA-sponsored contractors and grantees.

- **CONFERENCE PUBLICATION.** Collected papers from scientific and technical conferences, symposia, seminars, or other meetings sponsored or cosponsored by NASA.
- **SPECIAL PUBLICATION.** Scientific, technical, or historical information from NASA programs, projects, and missions, often concerned with subjects having substantial public interest.
- **TECHNICAL TRANSLATION.** English-language translations of foreign scientific and technical material pertinent to NASA's mission.

Specialized services also include organizing and publishing research results, distributing specialized research announcements and feeds, providing information desk and personal search support, and enabling data exchange services.

For more information about the NASA STI program, see the following:

- Access the NASA STI program home page at <http://www.sti.nasa.gov>
- E-mail your question to help@sti.nasa.gov
- Phone the NASA STI Information Desk at 757-864-9658
- Write to:
NASA STI Information Desk
Mail Stop 148
NASA Langley Research Center
Hampton, VA 23681-2199



Procedure for Determining Turbulence Length Scales Using Hotwire Anemometry

Lamyaa A. El-Gabry
The American University in Cairo, New Cairo, Egypt

Douglas R. Thurman
U.S. Army Research Laboratory, Glenn Research Center, Cleveland, Ohio

Philip E. Poinsette
Glenn Research Center, Cleveland, Ohio

National Aeronautics and
Space Administration

Glenn Research Center
Cleveland, Ohio 44135

Acknowledgments

The authors would like to acknowledge the support of the NASA Glenn Faculty Fellowship program and the input of Dr. Khairul Zaman on hotwire measurements.

Trade names and trademarks are used in this report for identification only. Their usage does not constitute an official endorsement, either expressed or implied, by the National Aeronautics and Space Administration.

This work was sponsored by the Fundamental Aeronautics Program at the NASA Glenn Research Center.

Level of Review: This material has been technically reviewed by technical management.

Available from

NASA STI Information Desk
Mail Stop 148
NASA Langley Research Center
Hampton, VA 23681-2199

National Technical Information Service
5301 Shawnee Road
Alexandria, VA 22312

Available electronically at <http://www.sti.nasa.gov>

Procedure for Determining Turbulence Length Scales Using Hotwire Anemometry

Lamyaa A. El-Gabry
The American University in Cairo
New Cairo, 11835, Egypt

Douglas R. Thurman
U.S. Army Research Laboratory
Glenn Research Center
Cleveland, Ohio 44135

Philip E. Poinsette
National Aeronautics and Space Administration
Glenn Research Center
Cleveland, Ohio 44135

Abstract

Hotwire anemometers are used to measure instantaneous velocity from which the mean velocity and the velocity fluctuation can be determined. Using a hotwire system, it is possible to deduce not only the velocity components and their fluctuation but to also analyze the energy spectra and from that the turbulence length scales. In this experiment, hotwire anemometry is used to measure the flow field turbulence for an array of film cooling holes. The objective of this paper is to document the procedure that is used to reduce the instantaneous velocity measurements to determine the turbulence length scales using data from the film-cooling experiments to illustrate the procedure.

Introduction

Hotwire systems have several advantages for turbulence research including lower cost than other systems such as laser Doppler anemometers, high frequency response, small size, and lower noise/signal ratio (Ref. 1). Hotwire anemometry relies on the principle of convective heat transfer to measure velocity. The heated wire or film element is placed in the flow field; changes in fluid velocity will change the resistance of the wire. The wire being very thin instantly responds to the change in fluid conditions. The output of the hotwire is a voltage signal that can be calibrated to velocity from which mean and turbulence quantities can be determined.

The objective of the current study is to characterize the turbulence field for an array of film cooling holes at a high blowing ratio where the jet is detached. The detailed turbulence measurements are an enabler for the development and improvement of numerical methods and tools for predicting film cooling flow and heat transfer. Turbulence is a familiar notion but remains a complex physical phenomenon to model and predict. Bradshaw (Ref. 2) defines turbulence as “a three-dimensional time-dependent motion in which vortex stretching causes velocity fluctuations to spread to all wavelengths between a minimum determined by viscous forces and a maximum determined by the boundary conditions of the flow.” Some describe turbulence in terms of an energy cascade in which large scale vortices are dissipated into smaller vortices which in turn dissipate into yet smaller scales and so on until the viscous effects dominate and the turbulence energy is dissipated into heat. A detailed description of the associated length scales and mechanism of turbulent transport is beyond the scope of this technical memo. The authors refer readers to several seminal texts on the subject (Refs. 2 and 3).

Experimental Apparatus

The apparatus, shown in Figure 1, consists of an open-loop wind tunnel with a temperature-controlled coolant loop. The tunnel is a suction type tunnel that draws air from the room and passes it through flow conditioning screens prior to entering the test section. The freestream velocity is 30 ft/sec, and the Reynolds number based on freestream velocity and coolant hole diameter is 11,000. The test section is a square section 8.2 by 8.2 in. and 34 in. in length.

The model consists of a three-hole array of film cooling holes that are fed by three long tubes. The model is inserted into the test section of the tunnel such that the heat transfer surface forms the wind tunnel floor. The cooling holes have a diameter $D = 0.75$ in., spacing $P/D = 3$, and are angled 30° from the streamwise direction. The coolant was fed through a manifold into three separate flow meters, then through 18 in. of hose and 12 in. of acrylic tube. The entire coolant path was insulated.

Velocity and turbulence are measured using a two-wire hotwire system for obtaining components. The hotwire is powered by a constant temperature anemometry system, and data is acquired at a rate of 50 kHz for 3 sec. Two different X-wire probes are used; one is used to measure the U - and V -components of velocity, and the other is used to measure the U - and W -components. In both cases, the two wires of the probe are separated by some distance and crossed to make an “X” shape. Figure 2 shows the probe (TSI Model 1246) used to measure the U - and W -components, and Figure 3 shows the probe (TSI Model 1240) used to measure the U - and V -components.

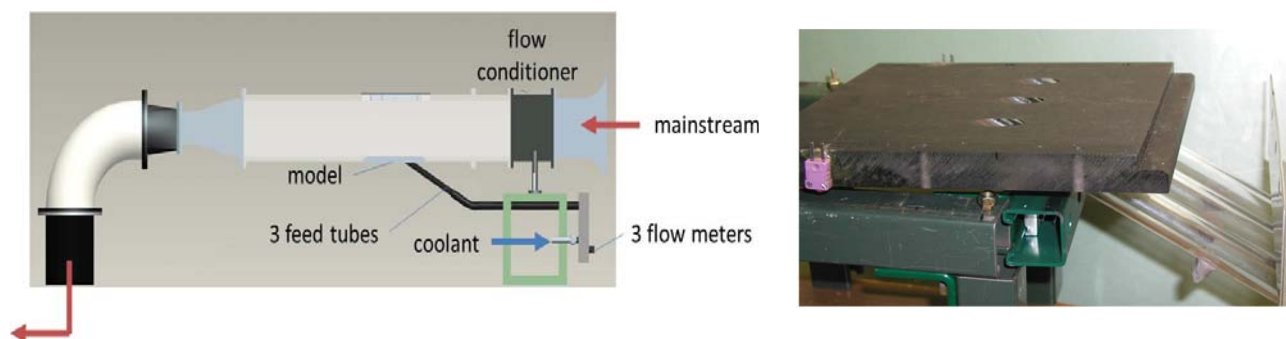

Figure 1.—Wind tunnel test apparatus (left) and film cooling model (right).

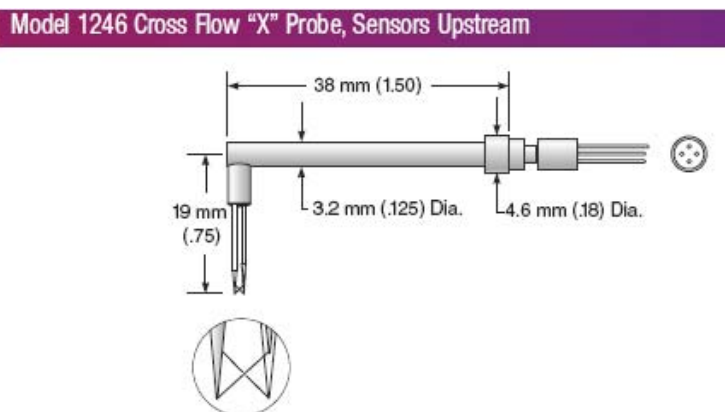

Figure 2.—TSI Probe Model 1246 for measuring U - and W -components of velocity.

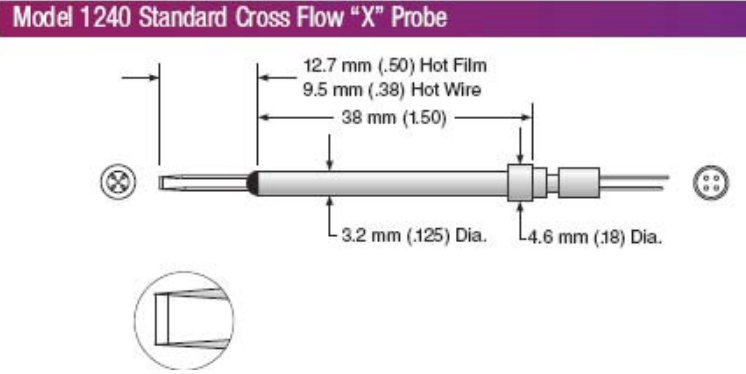

Figure 3.—TSI Probe Model 1240 for measuring U - and V -components of velocity.

Procedure

Calibration

The probes are calibrated in-situ, with the probe located upstream of the film cooling holes at mid-height of the tunnel and the coolant flow shut off. The freestream velocity, measured using total and static pressure probes, is then varied from 0 to 150 ft/s, and the wire voltage is measured and recorded at each freestream velocity. A calibration curve for one of the probes is shown in Figure 4. The points are curve fit using a 4th order polynomial that relates the delta voltage (the difference between the mainstream velocity voltage and the zero velocity voltage) for each wire to the freestream tunnel velocity. This velocity is assumed to be in the streamwise direction with no V - or W -components. The calibration is verified at the start of each run and repeated as needed.

Velocity Trace

During tunnel operation, the wire voltages are recorded to a data acquisition system and converted to velocity using the calibration curves to obtain the velocity components. As an example, Figure 5 shows the velocity trace at a location upstream of the cooling hole leading edge along the centerline of the tunnel and 1.0 in. above the floor of the tunnel. The mean velocity, U_{mean} , is 32 ft/s. The standard deviation, \bar{u} , of the velocity is 0.32 ft/s. Therefore the turbulence intensity, \bar{u}/U_{mean} , at this location is 1 percent.

Turbulence Energy Density Spectra Analysis

The velocity signal shown in Figure 5 is in the time domain. By using a fast Fourier transformation (FFT), the data can be transformed to the frequency domain. The Mathworks Inc. software package Matlab is used for the analysis. The Appendix contains a listing of the Matlab script, parts of which are repeated here for clarity.

FFT Analysis Transforms U From Time to Frequency Domain

The velocity trace in Figure 5 contains 150,000 points (sampling frequency of 50 kHz for 3 sec). Let U be the array consisting of the 150,000 velocity points sampled over the 3-sec duration. $aFData$ is the FFT of the U -velocity (i.e., the transform into the frequency domain). L is the length of the signal.

$$aFData = \text{fft}(U)$$

$$L = \text{length}(aFData)$$

The FFT of the U -velocity signal results in half the number of unique points, so let

$$n = L/2 = 150,000/2 = 75,000$$

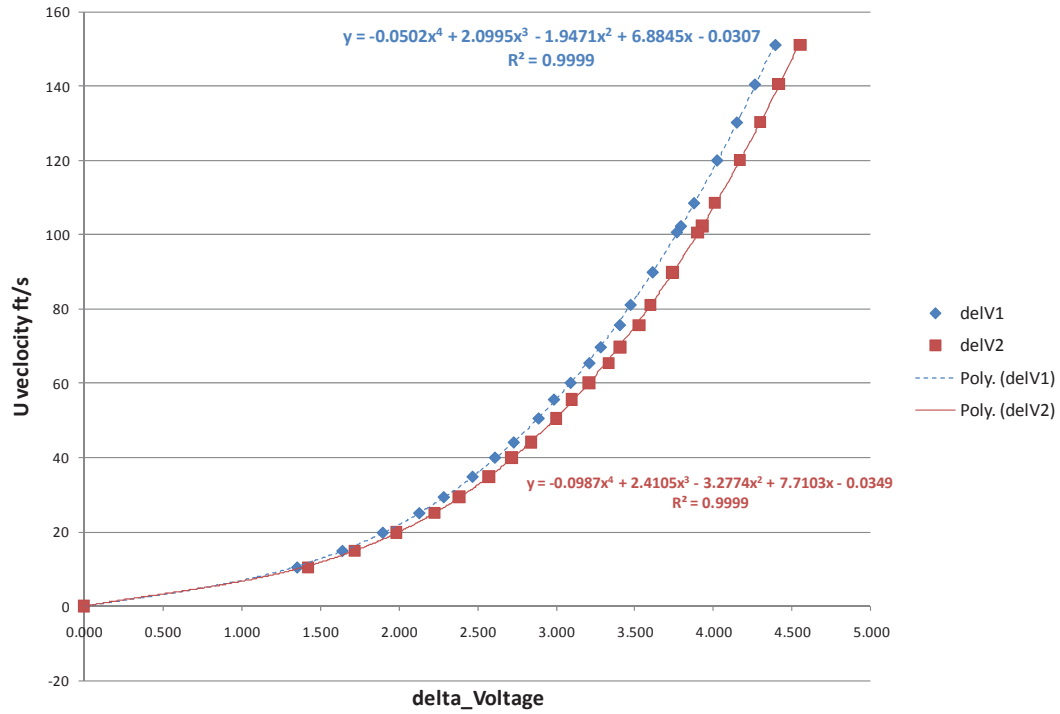

Figure 4.—Sample hotwire calibration curve for two-wire probe.

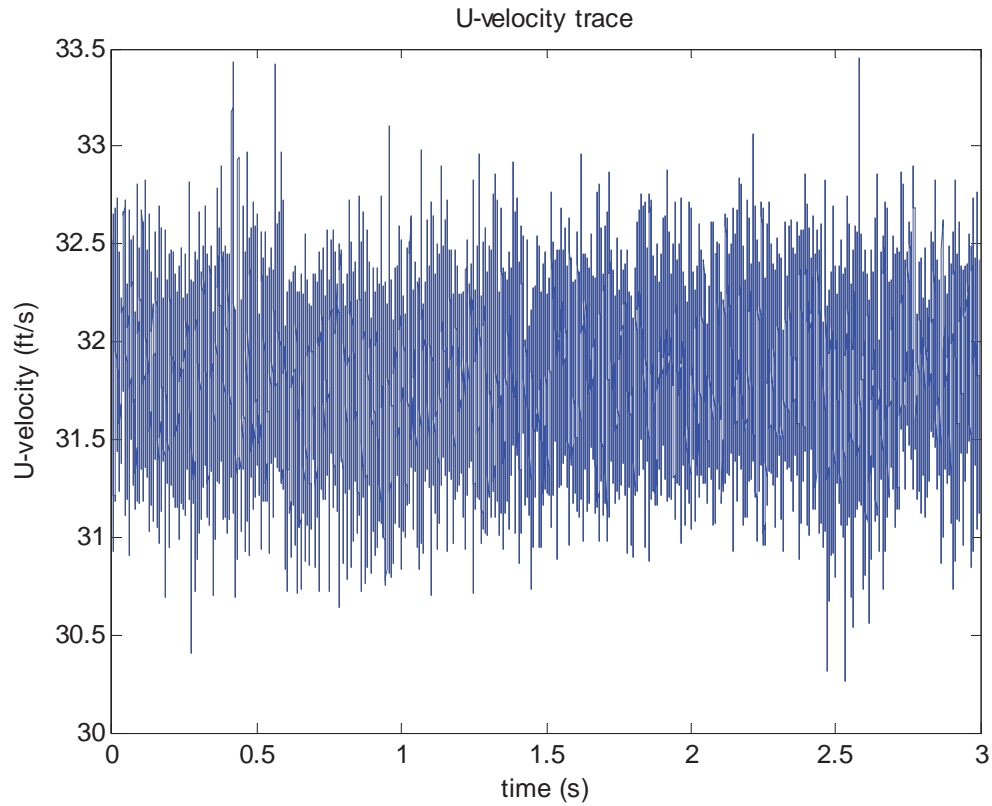

Figure 5.—*U*-velocity trace in the freestream.

Plot Amplitude and Power Spectra of U -Velocity

To plot the velocity in the frequency domain, the absolute value of the FFT is used to calculate the magnitude, or amplitude, of the velocity array, i.e.

$$aFMag = \text{abs}(aFData(1:n)/L)$$

Here, L is used to normalize the data. The corresponding frequency array is

$$aFreq = Fs*(1:n)/n$$

Figure 6 is the amplitude spectrum of the U -velocity component. The amplitude ranges from 0 to the mean velocity 32 ft/s. The first point in the FFT corresponds to the zero frequency and mean velocity. This first point has been removed from the plot to enable us to analyze the turbulence energy.

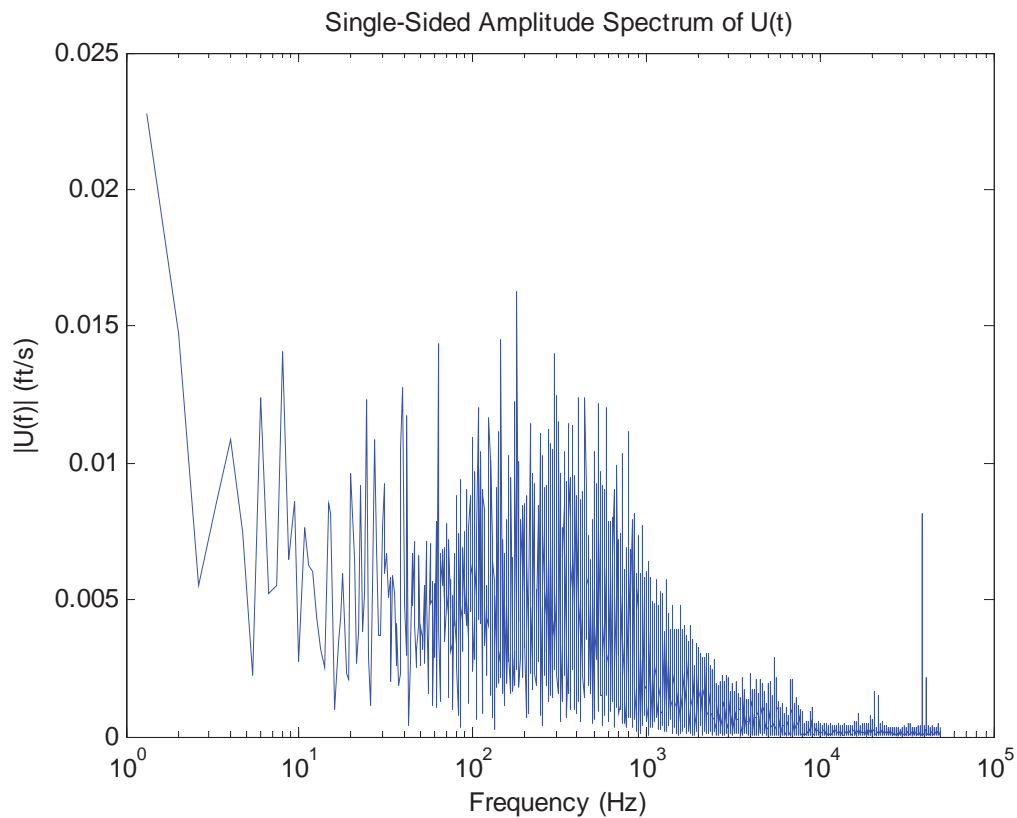

Figure 6.—Amplitude spectrum of U -velocity (omitting mean velocity at 0 Hz).

Power is defined as:

$$\text{Power} = \text{abs}(\text{fft}(U)).^2/L$$

Dividing by L ensures that the power is independent of the length of the signal. The energy $E(f)$ can be determined by dividing power by the frequency. The energy density spectrum is shown in Figure 7.

Integral Length Scale

The integral length scale, Λ_x (macro-scale), is a measure of the largest eddy size in the turbulent fluid and is calculated using the method shown by Roach (Ref. 4):

$$\Lambda_x = \left[\frac{E(f)U_{\text{mean}}}{4\bar{u}^2} \right]_{f \rightarrow 0}$$

where \bar{u} is the standard deviation of the U -velocity. To get $E(f)$ as the frequency approaches zero from the data, the first 100 points are averaged, where the data asymptotes to a fixed value at the low frequencies. The dashed yellow line in Figure 7 shows $E(f)$ as f approaches zero, and is determined to be $1.3445e^{-4}$. Thus the length scale is calculated to be

$$\Lambda_x = \frac{(1.3445e^{-4} \frac{ft^2}{s})(31.8 \frac{ft}{s})}{4(0.32^2 \frac{ft^2}{s^2})} = 0.0105 ft = 0.1256 in.$$

The length scale at this location (freestream inlet) is found to be about $1/8^{\text{th}}$ in., which is roughly the size of the wire mesh upstream of the test section.

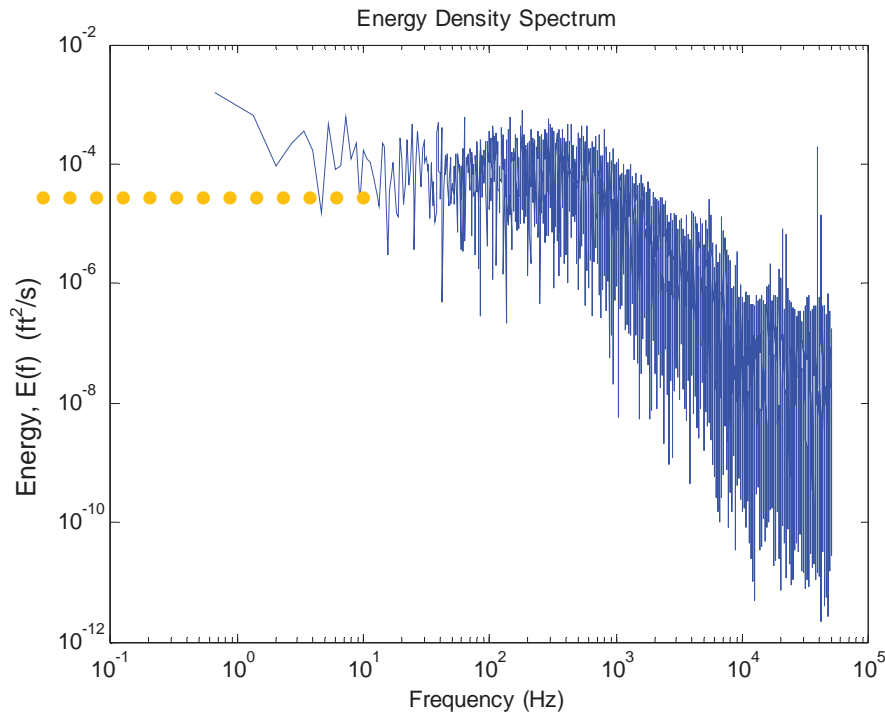

Figure 7.—Energy density spectrum of U -velocity.

Dissipation Length Scale

The dissipation length scale, λ_x (micro-scale), is a measure of the average dimension of the eddies responsible for the dissipation of turbulent energy. It is calculated as shown by Roach (Ref. 4):

$$\frac{1}{\lambda_x^2} = \frac{2\pi^2}{U^2 u^2} \int_0^\infty f^2 E(f) df$$

The trapezoid rule is used for the numerical integration; the integration yields $2.3067e^6 \text{ ft}^2/\text{s}^4$.

$$\frac{1}{\lambda_x^2} = \frac{2\pi^2}{(31.8^2 \frac{\text{ft}^2}{\text{s}^2})(0.32^2 \frac{\text{ft}^2}{\text{s}^2})} \left[2.3067e^6 \frac{\text{ft}^2}{\text{s}^4} \right] = 4.4001 e^5 \frac{1}{\text{ft}^2}$$

$$\therefore \lambda_x = 0.0015 \text{ ft} = 0.0181 \text{ in.}$$

Results

The same procedure for calculating the length scale is repeated at each measurement location. Figure 8 shows the integral length scale along the centerline of the central cooling hole. Figure 9 shows the dissipation length scale along the jet centerline. The integral length scale is the size of the largest eddy. Note that at the hole location, the integral length scale is roughly 0.75 in. which is the diameter of the coolant hole. The dissipation length scale is smaller and is independent of the geometry. Whereas the integral length scale decreases in the flow direction as the coolant mixes and diffuses in the freestream, the micro-scale does not decrease or increase with the flow direction. The macro-scale decreases as the larger eddies break down into smaller eddies.

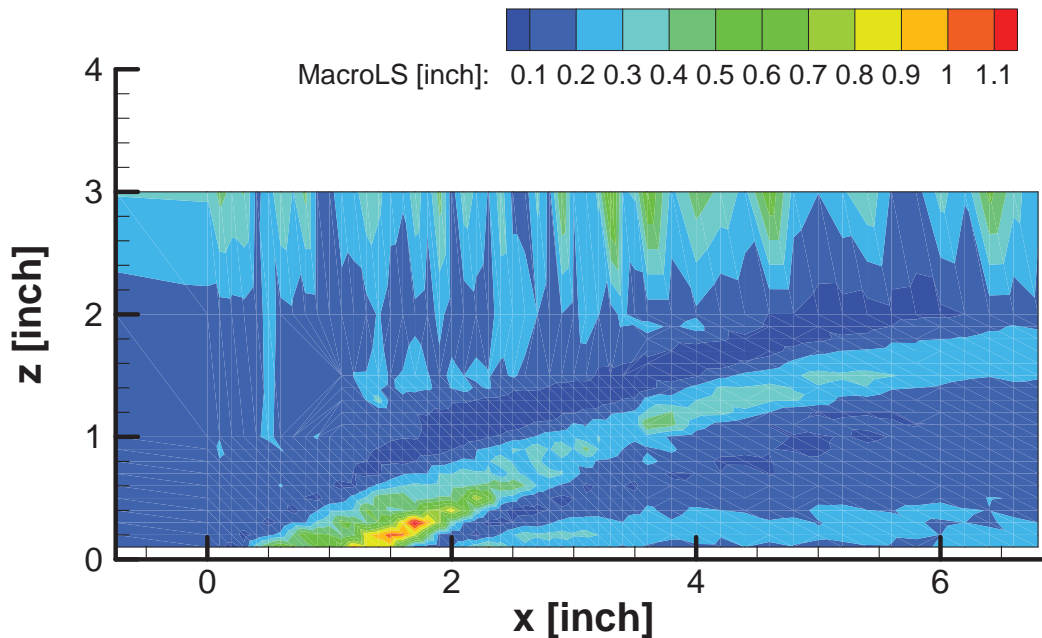

Figure 8.—Integral length scale contour along jet centerline.

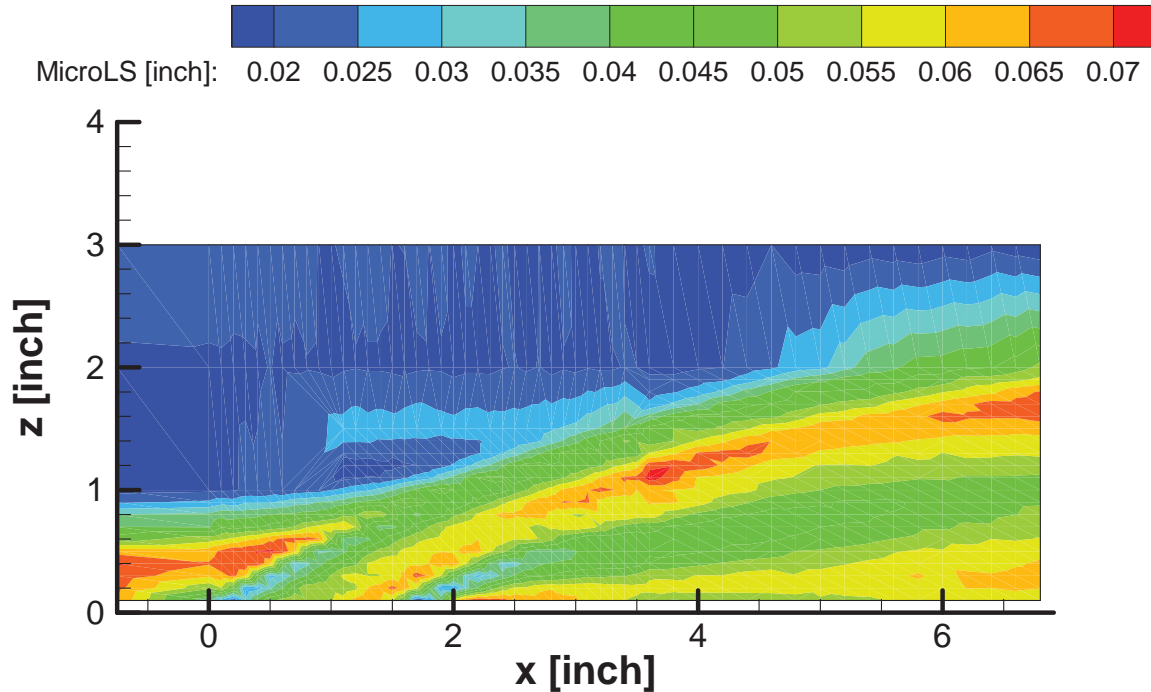

Figure 9.—Dissipation length scale contour along jet centerline.

Conclusions

The procedure for calculating the turbulence length scales from using hotwire anemometry is outlined, and a data point in the freestream inlet is calculated to illustrate the process. The instantaneous velocity signal obtained using a hotwire anemometer is processed using a fast Fourier transform to convert the signal from the time domain to the frequency domain. The magnitude is plotted against the frequency to yield the amplitude spectrum. The energy spectrum is obtained and plotted against frequency. It is from the energy spectrum and equations derived in Roach (Ref. 4) that the integral length scale (macro-scale) and dissipation length scale (micro-scale) are calculated. The results for the length scales along the centerline are plotted and discussed. The integral length scale is commensurate with the geometry. At the inlet, the integral length scale is approximately the size of the wire mesh upstream, while at the hole discharge, the integral length scale is roughly equal to the hole diameter. The integral length scale decreases in the flow direction as large eddies dissipate into smaller eddies. The micro-scale is at least one order of magnitude smaller than the integral length scale, and unlike the macro-scale, it appears to be independent of geometry and flow direction.

References

1. Bruun, H.H., 1995, "Hot-Wire Anemometry Principles and Signal Analysis," Oxford University Press: Oxford, UK.
2. Bradshaw, P., 1971, "An Introduction to Turbulence and its Measurement," Pergamon Press: Oxford, UK.
3. Hinze, J.O., 1957, "Turbulence," McGraw-Hill: New York, USA.
4. Roach, P.E., 1986, "The generation of nearly isotropic turbulence by means of grids," Heat and Fluid Flow, vol. 8, No. 2, pp. 82-92.

Appendix—MATLAB Script

```
% Read in the two wire signal and process it to get velocity
E1 = data(:,1);           %let column 1 be voltage 1 (wire 1)
E2 = data(:,2);           %let column 2 be voltage 2 (wire 2)
E0_1 = 4.667;             %Zero voltage for wire 1
E0_2 = 4.336;             %Zero voltage for wire 2
delE1 = E1 - E0_1;
delE2 = E2 - E0_2;
a1=0.1839;
b1=-0.198;
c1=3.9795;
d1=1.8669;
a2=0.134;
b2=0.259;
c2=2.9707;
d2=1.8816;
vel1=a1*delE1.^4+b1*delE1.^3+c1*delE1.^2+d1*delE1;
vel2=a2*delE2.^4+b2*delE2.^3+c2*delE2.^2+d2*delE2;
U=0.5*(vel1+vel2);
W=0.5*(vel1-vel2);

% Plot the U-velocity trace
Fs=50000;                 % Sampling frequency of 50 kHz
L=length(U);              % Number of samples
t=(0:L-1)/(Fs);           % Time vector
plot(t,U);                 % Plot the velocity trace
title('U-velocity trace');
ylabel('U-velocity (ft/s)');
xlabel('time (s)');

% Perform FFT analysis on the U-velocity signal and plot Amplitude spectrum
aFData=fft(U);             % Take FFT of U signal
n=L/2;                     % FFT will yield half the number of unique points
aFreq=Fs*(1:n)/n;         % Frequency array (half the length of signal)
aFMag=abs(aFData(1:n)/L); % Normalized Magnitude array (half the length of
signal)
figure;
semilogx(aFreq(2:n),aFMag(2:n)) % Plot frequency against magnitude
title('Single-Sided Amplitude Spectrum of U(t)')
xlabel('Frequency (Hz)')
ylabel('|U(f)| (ft/s)')

% Plot the energy density spectrum
Power=abs(fft(U)).^2/L;    %Power is the magnitude squared by L
Energy=Power/Fs;
figure
loglog(aFreq,Energy(2:L/2+1))
title('Energy Density Spectrum')
xlabel ('Frequency (Hz)')
ylabel ('Energy, E(f) (=Power/frequency) (ft2/s)')
```

```

% Calculate the integral length scale (macro scale) Roach Eqn 15
uprime=std(U)
uprimesquared=uprime^2;
Ubar=mean(U)
Tu=uprime/Ubar
Ef0=mean(Energy(2:100))
IntegralLengthScale=Ef0*mean(U)/(4*uprimesquared)

% Calculate the dissipation length scale (micro scale) Roach Eqn 8
for i=1:length(aFreq)
    Y(i)=aFreq(i)*aFreq(i)*Energy(i);
end
Z=trapz(aFreq,Y) % Use trapezoid rule for integration
Z=Z*2*pi^2/(Ubar^2*uprimesquared);
DissipationScale=sqrt(1/Z)

```