

A Future with Hybrid Electric Propulsion Systems: A NASA Perspective

Dr. Rubén Del Rosario, P.E.

Project Manager

Fixed Wing Project

NASA Fundamental Aeronautics Program

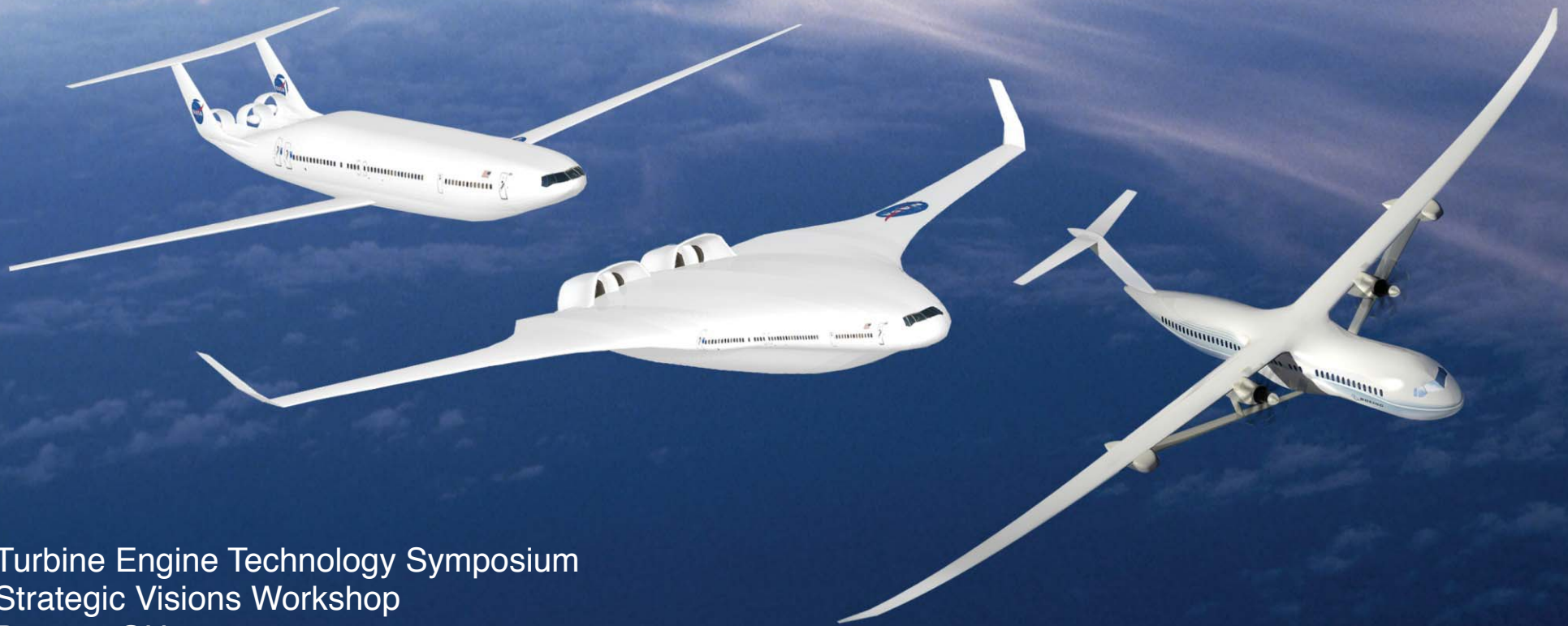

Turbine Engine Technology Symposium

Strategic Visions Workshop

Dayton, OH

September 11, 2014

www.nasa.gov



Outline of Talk

- Future Challenges of Commercial Aviation
- The NASA Fixed Wing (FW) Project
- Why Hybrid Electric Propulsion?
- NASA Fixed Wing Perspective on Enabling Hybrid Electric Propulsion for Commercial Transport Aircraft
- NASA Fixed Wing Investments in Hybrid Electric Propulsion
- Concluding Remarks

Why is aviation so important?

The air transportation system is critical to U.S. economic vitality



\$1.3 TRILLION
TOTAL U.S. ECONOMIC ACTIVITY
(civil and general aviation, 2009)

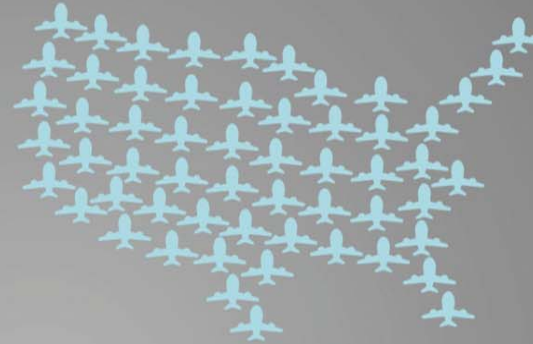

\$47.1 BILLION
POSITIVE TRADE BALANCE
(civil aviation, 2011)



10.2 MILLION
DIRECT AND INDIRECT JOBS
(civil and general aviation, 2009)

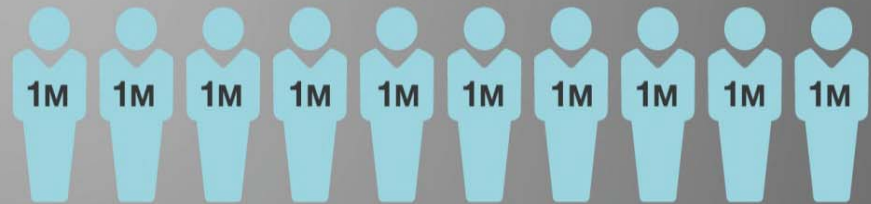

5.2%
OF TOTAL U.S. GROSS DOMESTIC PRODUCT (GDP)
(civil and general aviation, 2009)

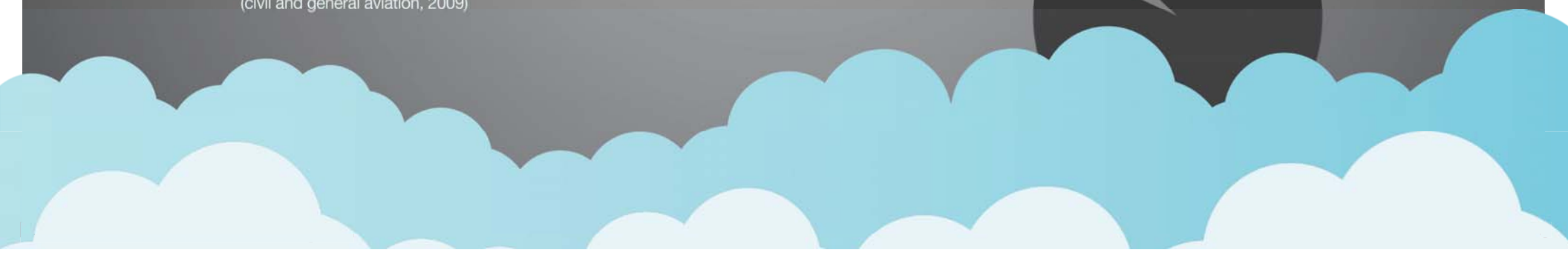

What do emerging global trends reveal?



Average increase in percentage point share of global GDP, per decade

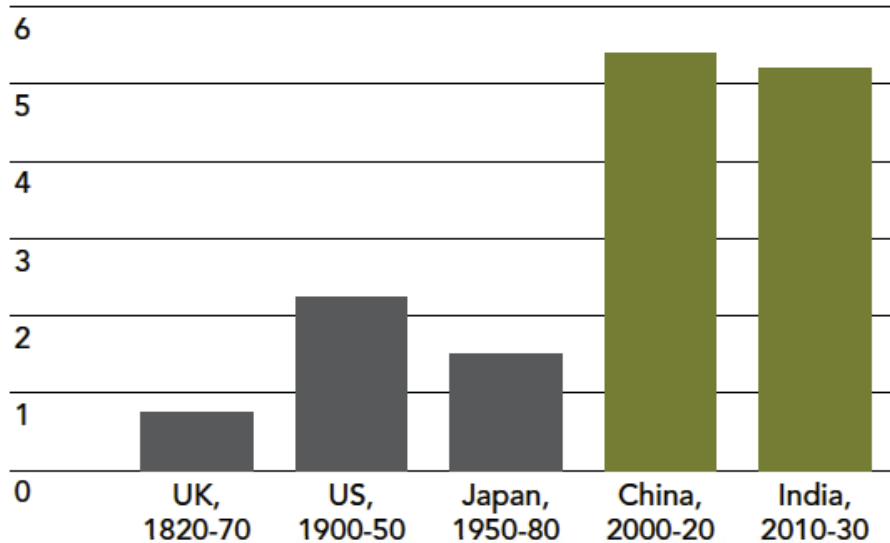

China and India are growing economically at unprecedented rates.

Asia-Pacific will have the largest middle class.

The world will be predominantly urban.

Revolutionary technology development and adoption are accelerating.

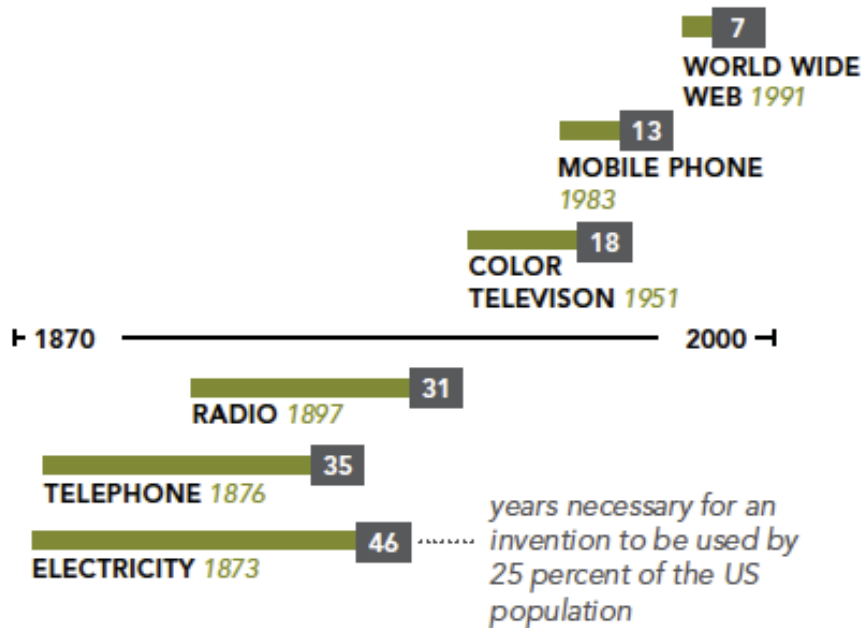

Source: National Intelligence Council

Why are these trends important?

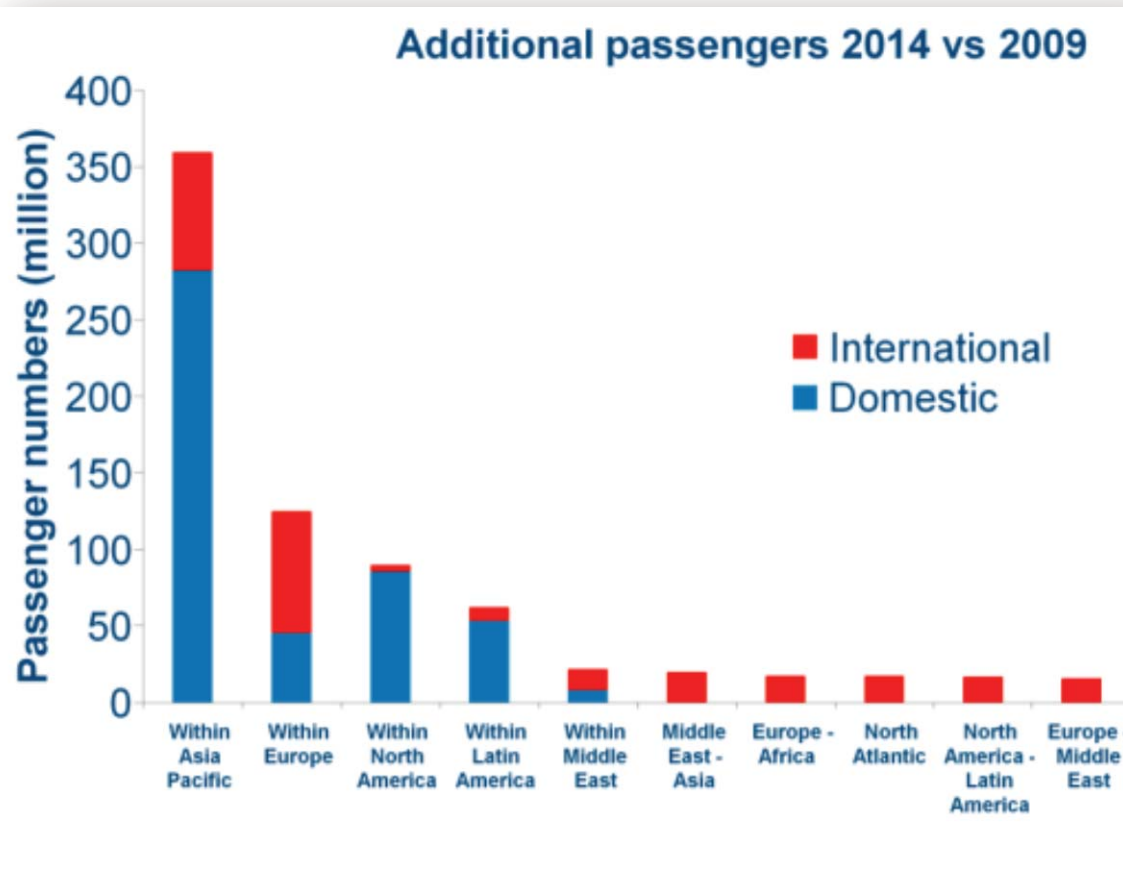

They drive global demand for air travel...

They drive expanding competition for high-tech manufacturing...

They drive “leapfrog” adoption of new technology and infrastructure...

They drive resource use, costs, constraints, and impacts...

They drive need for alternative energy technologies...

How Do These Trends Affect Aviation?

Three mega-drivers emerge

Emissions reduction roadmap

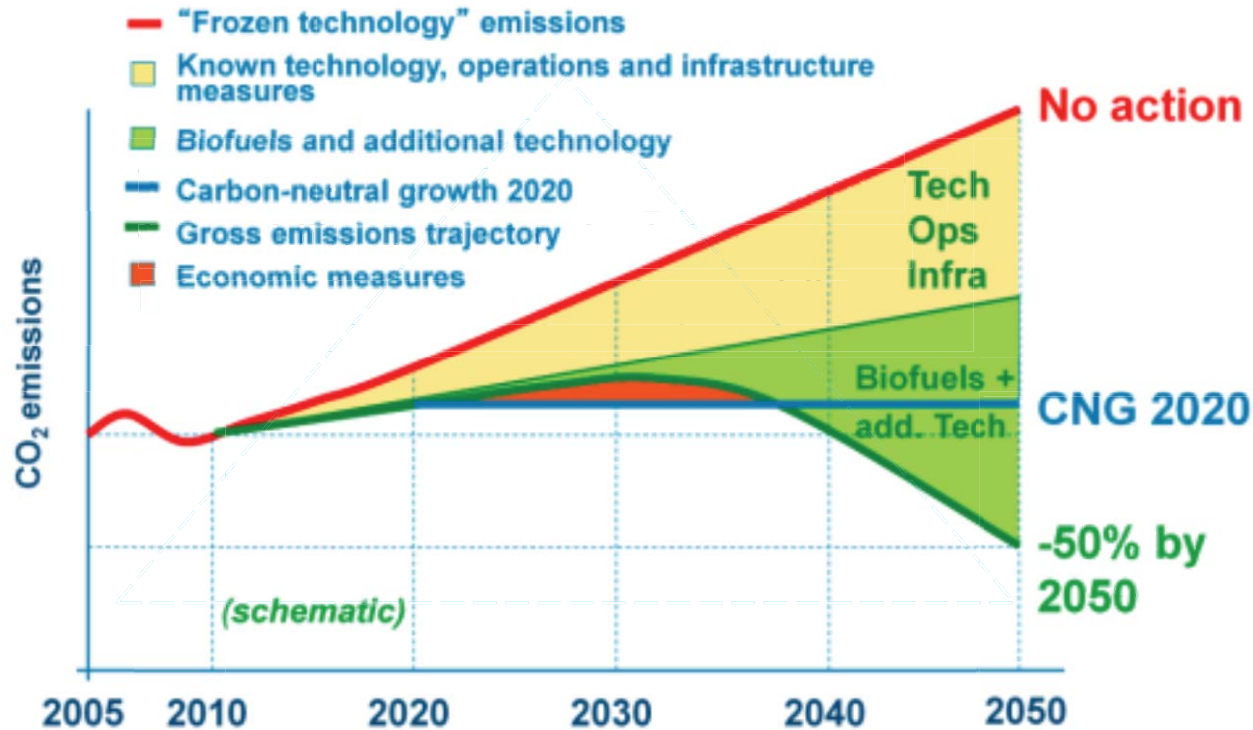

Emissions reduction roadmap

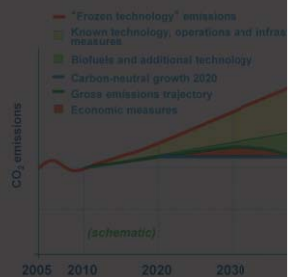

Severe energy and climate issues create enormous affordability and sustainability challenges

Revolutions in automation, information and communication technologies enable opportunity for safety critical autonomous systems

The NASA Fixed Wing Project

Explore and Develop Technologies and Concepts for Improved Energy Efficiency and Environmental Compatibility for Sustained Growth of Commercial Aviation

- Early stage exploration and initial development of game-changing technologies and concepts for fixed wing vehicles and propulsion systems
- Commercial focus, but dual use with military
- Along with Environmentally Responsible Aviation (ERA) project focused on subsonic commercial transport vehicles
- Research vision guided by vehicle performance metrics developed for reducing noise, emissions, and fuel burn

Evolution of Subsonic Transports



1903



DC-3

1930s



B-707

1950s



B-787

2000s



N+3 Advanced Vehicle Concept Studies Summary

Boeing, GE, GA Tech



Advanced concept studies for commercial subsonic transport aircraft for 2030-35 Entry into Service (EIS)



NG, RR, Tufts, Sensis, Spirit



Technology Trends:

- Tailored/multifunctional structures
- High aspect ratio/laminar/active structural control
- Highly integrated propulsion systems
- Ultra-high bypass ratio (20+ with small cores)
- Alternative fuels and emerging hybrid electric concepts
- Noise reduction by component, configuration, and operations improvements

GE, Cessna, GA Tech



MIT, Aurora, P&W, Aerodyne



NASA, VA Tech, GT



NASA



Copyright, The McGraw-Hill Companies, Penton Publications. Used with permission.

Advances required on multiple fronts...

NASA Fixed Wing Project Research Themes



Based on Goal-Driven Advanced Concept Studies

Goals Metrics (N+3)	Noise Stage 4 – 52 dB cum	Emissions (LTO) CAEP6 – 80%	Emissions (cruise) 2005 best – 80%	Energy Consumption 2005 best – 60%
---------------------	---------------------------	-----------------------------	------------------------------------	------------------------------------

Goal-Driven Advanced Concepts (N+3)

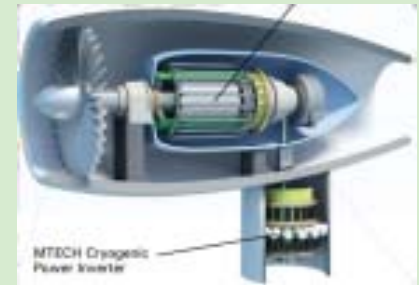
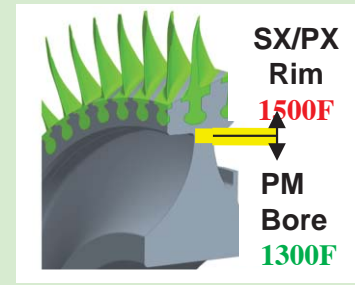
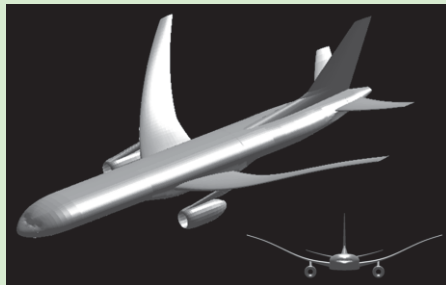
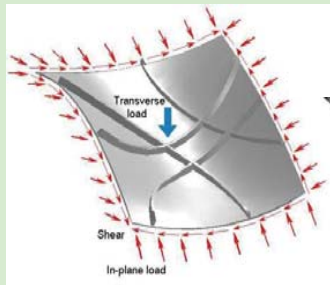

1. Lighter-Weight Lower Drag Fuselage

2. Higher Aspect Ratio Optimal Wing

3. Quieter Low-Speed Performance

4. Cleaner, Compact Higher BPR Propulsion

5. Hybrid Gas-Electric Propulsion

6. Unconventional Propulsion Airframe Integration

7. Alternative Fuel Emissions

Research Themes with Investments in both Near-Term Tech Challenges and Long-Term (2030) Vision

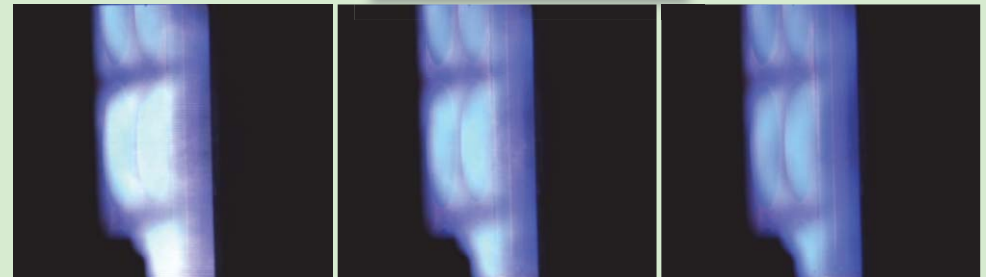
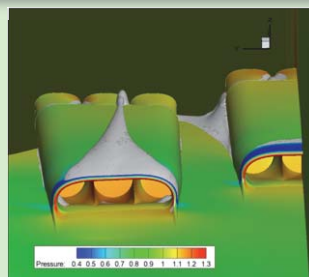

Hybrid Electric Propulsion for Commercial Transports



- The hybrid-electric promise - cleaner, quieter, conserves energy, less atmospheric heat release, more reliable
- Gen N+3/N+4 advanced concept studies have identified promising aircraft and propulsion systems
- Electric-based propulsion systems for commercial aircraft will enable national environmental and fuel burn reduction goals to be met
- Industry roadmaps acknowledge shift toward electric technologies
- Recent successes in development of all-electric GA aircraft and UAVs
- Research horizon is long-term but with periodic spinoff of technologies for introduction in aircraft with more- and all-electric architectures
- NASA can help accelerate key technologies in collaboration with other Government agencies, industry, and academia
- Research aligned with new NASA Aeronautics strategic R&T thrusts

Benefits Estimated From Advanced Concept Studies



Boeing SUGAR

(baseline Boeing 737, 2008 tech)

- ~60% fuel burn reduction
- ~53% energy use reduction
- 77-87% reduction in NOx
- 24-31 EPNdB cum noise reduction



NASA N3-X

(baseline Boeing 777-200)

- ~63% energy use reduction
- ~90% NOx reduction
- 32-64 EPNdB cum noise reduction



Possible Future Electric-Based Transport Aircraft

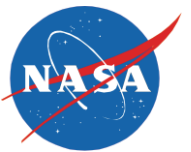

Concepts can use either non-cryogenic ambient temp or cryogenic superconducting technologies

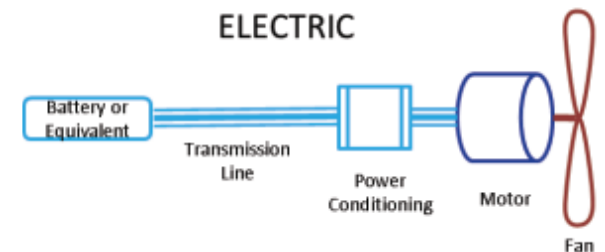
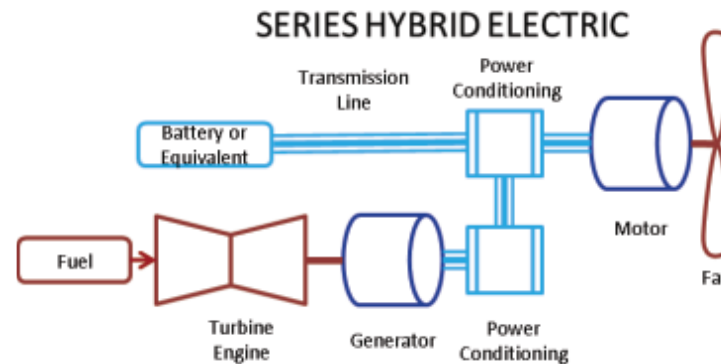
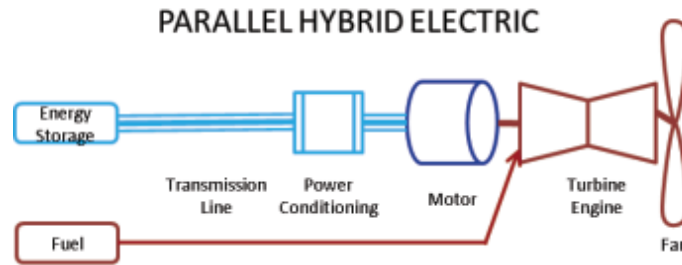
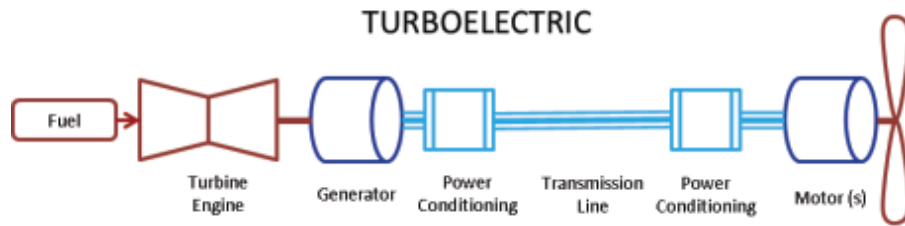

Boeing-GE "SUGAR-Volt" Hybrid Electric Propulsion

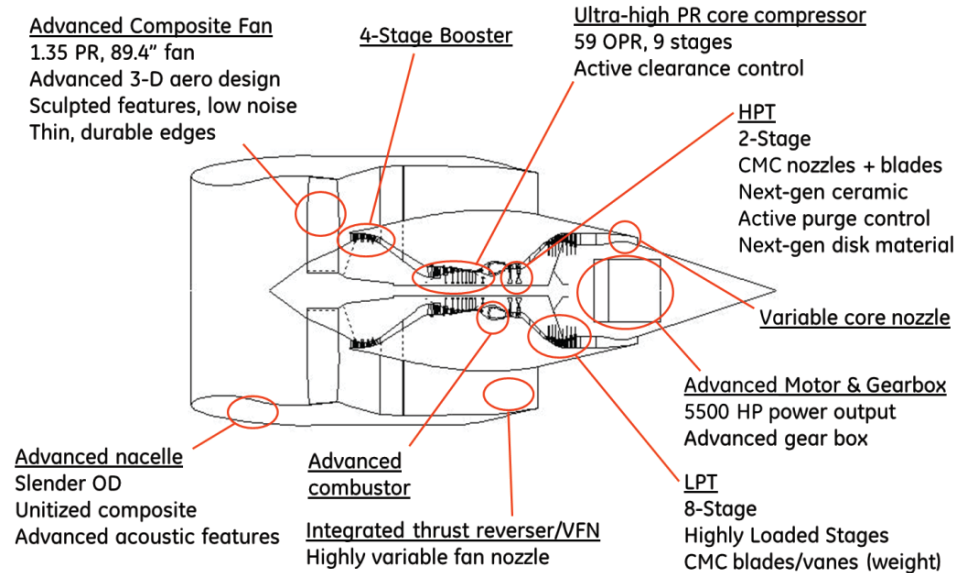
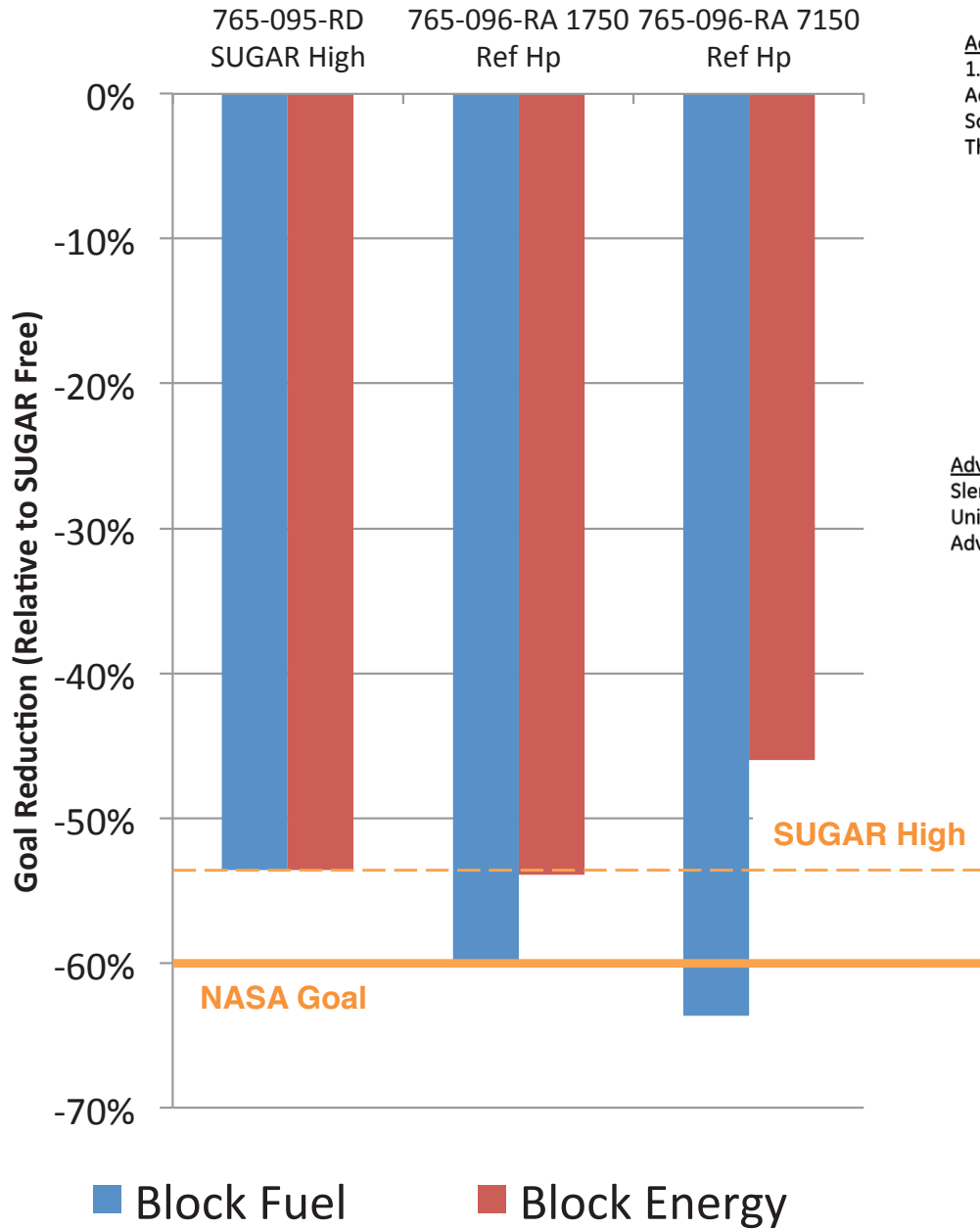

ESAero ECO-150 and Dual-Use Split-Wing Turboelectric Configuration

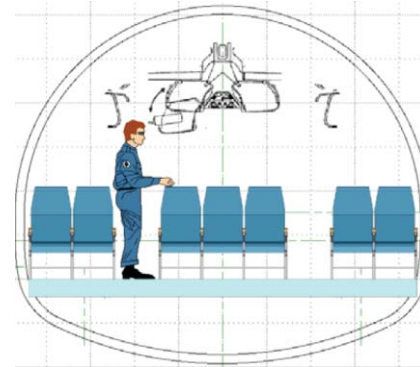
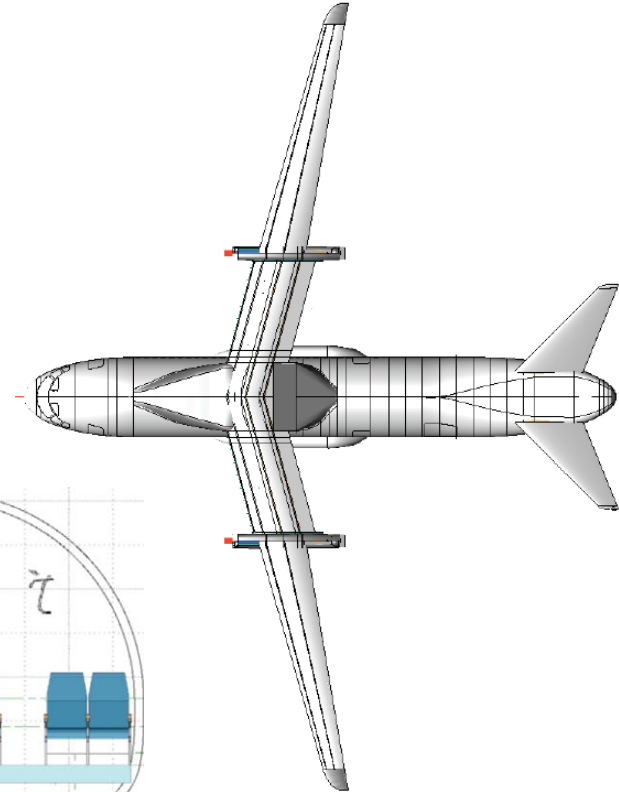
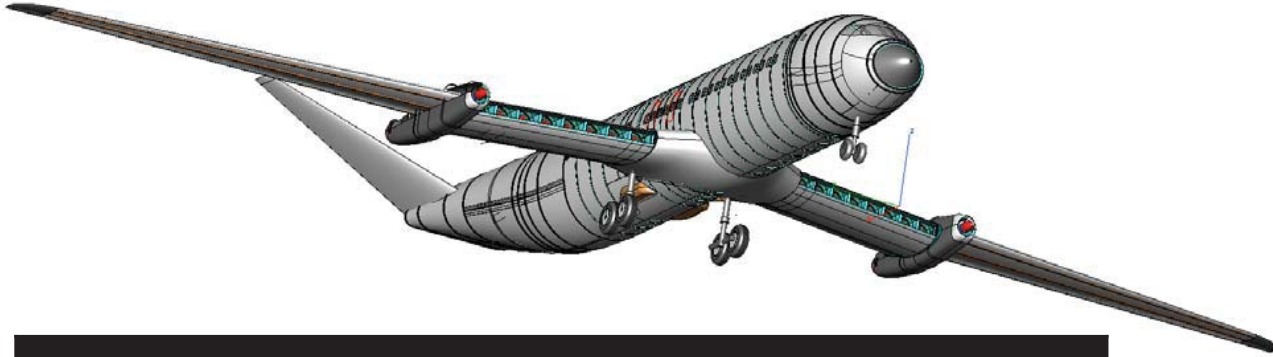

	ECO-150 (3-3)	DU-Civil (2-3-2)	737-700 (3-3)
TOGW	139,700	142,400	154,500
Propulsion Wt ("dry")	28,350	27,820	10,430
Payload*	30,000	30,000	24,000
Fuel*	28,900	28,900	46,612
Seat-Mile/ Gal	121	118	65
Motor hp/lb	2.46	Gen hp/lb	4.30

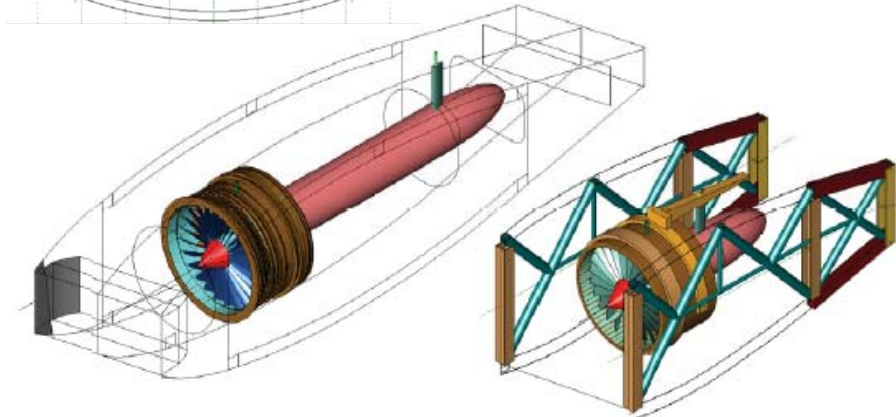

* At 3440 nm range

NASA N3X Turboelectric Distributed Propulsion



Low velocity core exhaust reduces noise.

...ies with freestream inlets drive superconducting generators.

Electric power from generators distributed to multiple motor-driven propulsors.

...gest er & fi center-body wake.

Many small fans give a large total fan area and very high effective bypass ratio

...fan by airframe.



Hybrid Electric Propulsion (HEP) Systems for Aviation



Power Level for Electrical Propulsion System

Spinoff Technologies Benefit More/All Electric Architectures:

- High power density electric motors replacing hydraulic actuation
- Electrical component and transmission system weight reduction

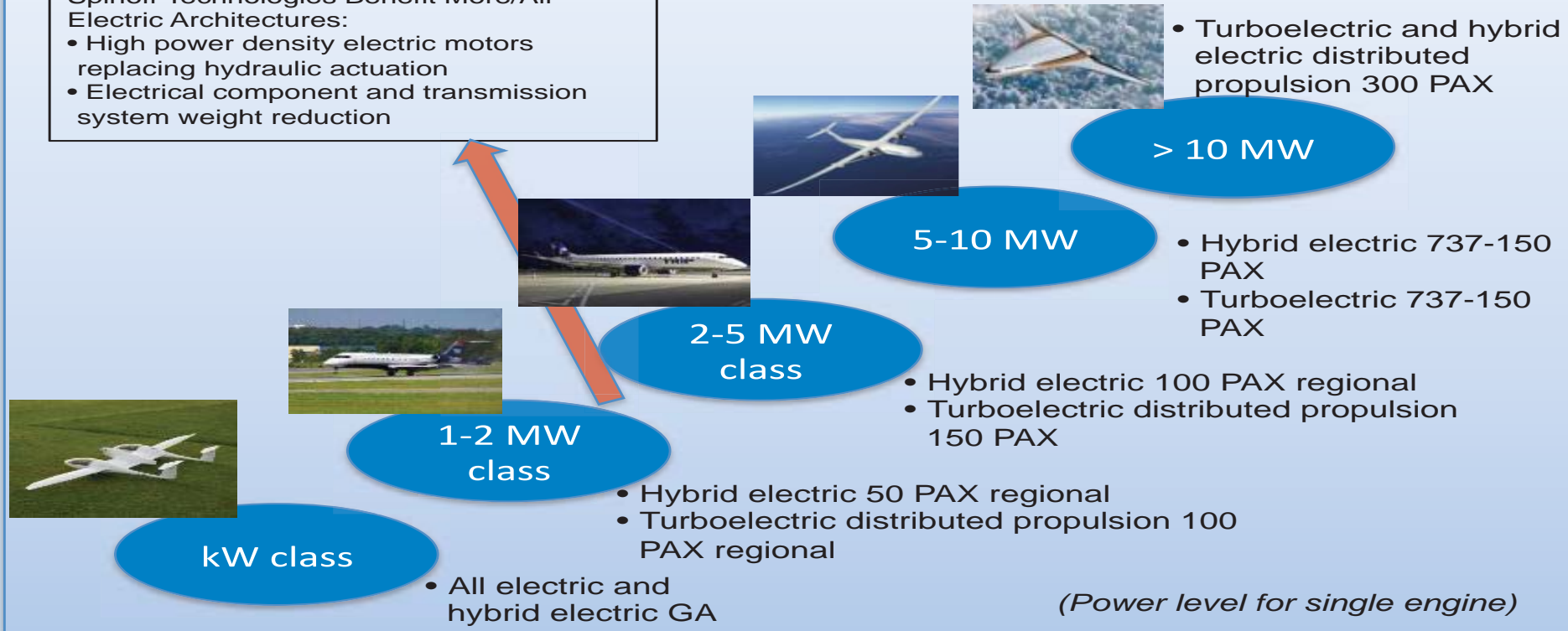

What is needed?

- Conceptual designs of aircraft and propulsion systems
- Higher power density generators and motors
- Flight-weight power system architectures and simulations
- Higher energy density energy storage systems (non-NASA)
- Extensive ground and flight testing



NASA FW HEP Technology Roadmap

MW Size Motors

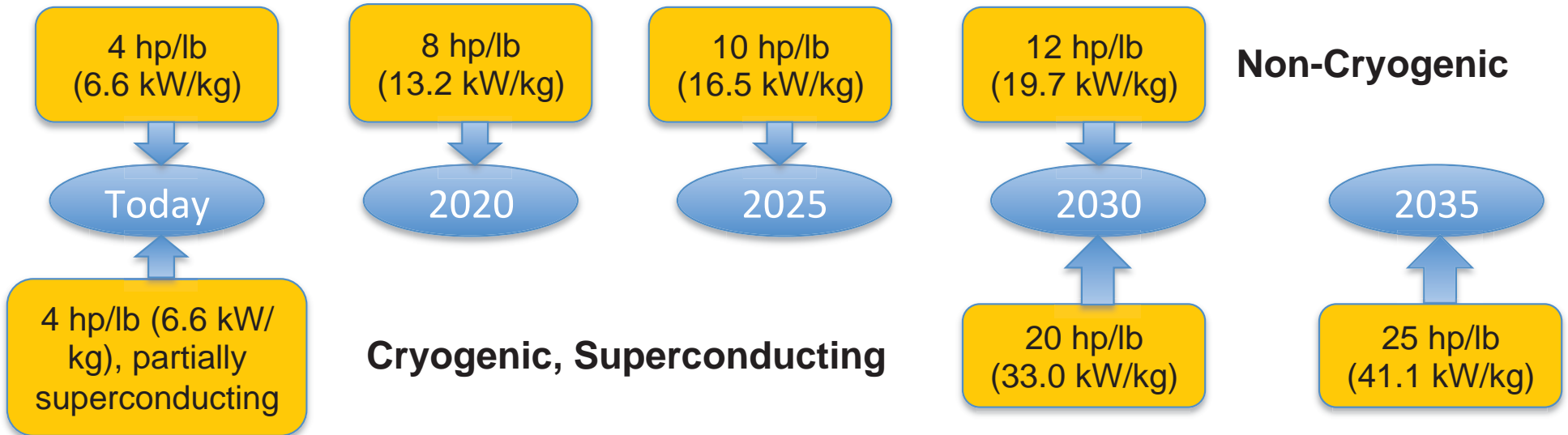

Power Electronics

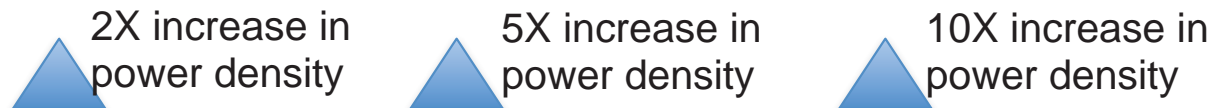

Power Transmission System

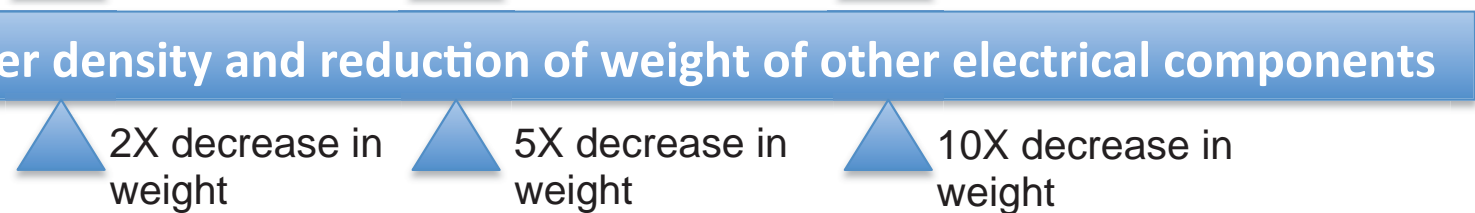

Electric Propulsion-Aircraft Integration

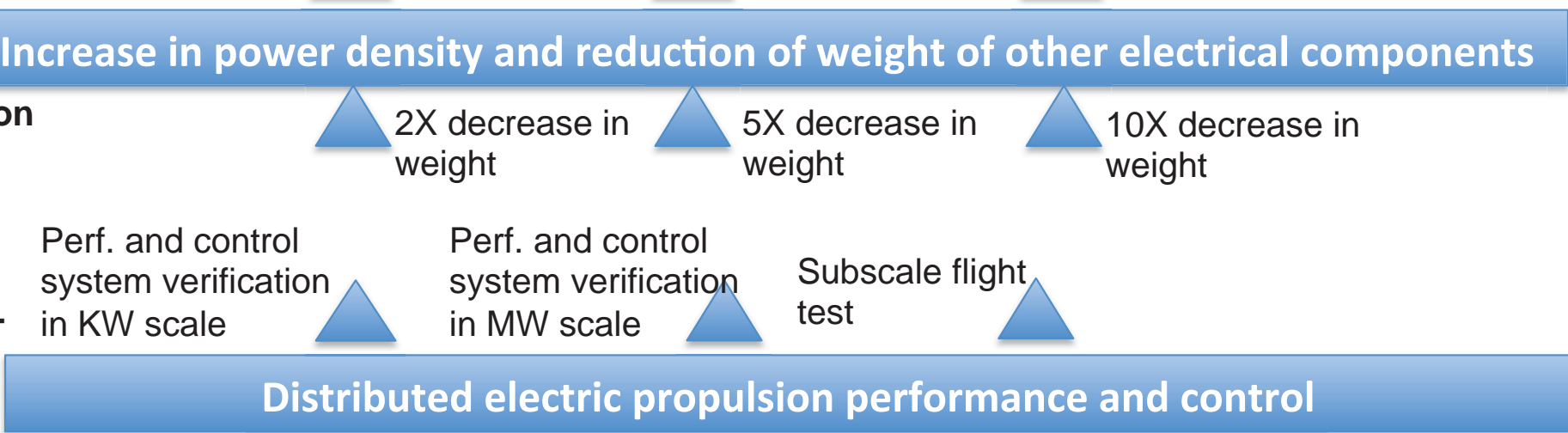
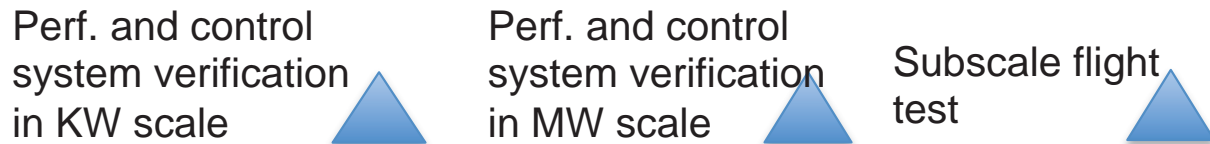

NASA FW HEP Technology Areas



Technical Areas and Approaches

Propulsion System Conceptual Design

- Reference hybrid electric propulsion system(s) for component maturation established
- Key technologies identified

High Power Density Motors and Generators

- Superconducting and non-cryo technologies
- Explore conventional and non-conventional topologies
- Integrate novel thermal management
- Develop advanced component materials

Flight-Weight Power System and Electronics

- High power electric grid architecture, modeling and simulation tools
- High voltage power electronics, transmission, and protection
- Lightweight power transmission materials
- Control systems for distributed propulsion

Integrated Subsystem Testing

- Component interactions – validate performance and matching at steady-state and transient operation
- Validate control methodologies
- Validation experiments, system demos, flight tests



Gas turbine-battery hybrid

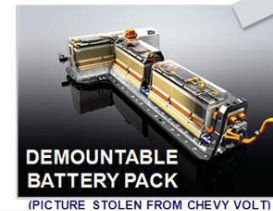

Superconducting turboelectric distributed propulsion

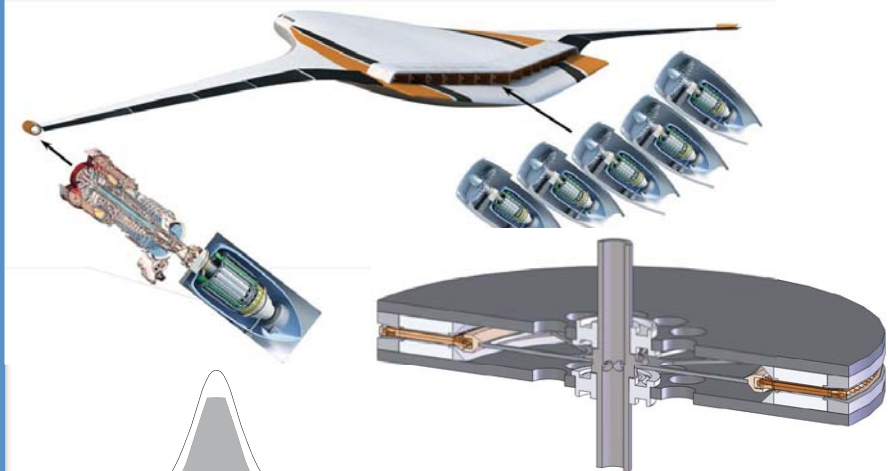

High Power Density, Non-cryogenic Motor

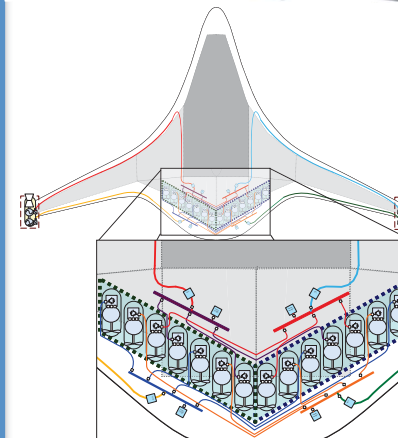

Propulsion power grid architecture

NASA FW HEP Recent Activities



Recent Activities

Superconducting Motors

- Cryocoolers, superconducting wire, power management components, AC loss analysis and motor design
- AML, U of Houston, Creare, MTECH, Hypertech
- Fully superconducting subscale motor test in 2017

High Power Density, Non-cryogenic Motors

- Boeing SUGAR concept
- Initiating new NRA efforts leading to 1MW scale non-cryo motor test in 2019

Distributed Propulsion

- NASA N3-X, ESAero ES-150 concepts
- AirVolt and Hybrid AirVolt test stands

Power Management

- Propulsion Electric Grid Simulator
- RR, GE contracts for high-power electrical grid architecture, voltage, and components for turboelectric aircraft

Other Related NASA Activities

- GA-scale distributed electric propulsion concept validation leading to flight demo
- Electric-based propulsion for rotorcraft
- Design competitions targeting small electric aircraft
- Coordinating research activities across several OGAs – AF; Navy - NAVSEA, Electric Ships Office, NPS; Army; DOE-LLNL; NASA

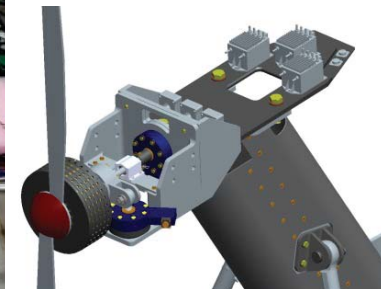
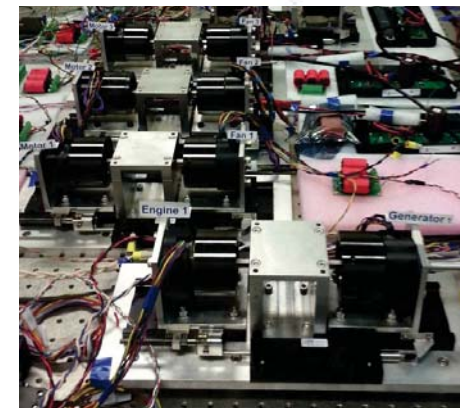
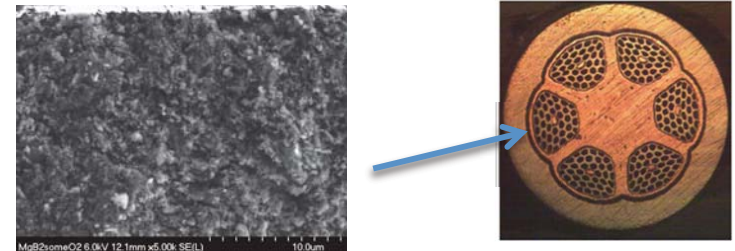
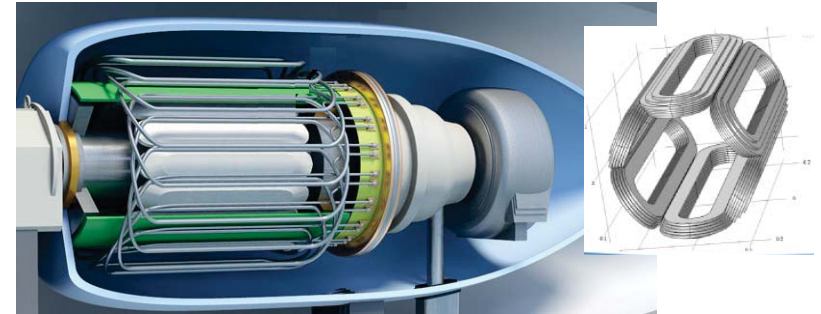



The Way Forward

- Conceptual designs and trade studies for electric-based concepts
- Tech development and demonstration for N+3 MW class aircraft
- Development of core technologies, i.e., turbine coupled motors, propulsion integration modeling, power architectures, power electronics, thermal management, flight controls
- Multi-platform (turbo-, hybrid-, all-electric) technology testbeds
 - Fully superconducting motor
 - 8 hp/lb (2x SOA) non-cryogenic electric motors
 - 2x power density increase for power electronics
 - Performance and control system verification for distributed electric propulsion at kW scale
- Development of multi-scale modeling and simulation tools
- Focus on future large regional jets and single-aisle twin (Boeing 737-class) aircraft for greatest impact on fuel burn, noise and emissions

