



Launch Vehicle Manual Steering with Adaptive Augmenting Control: In-Flight Evaluations of Adverse Interactions Using a Piloted Aircraft

Curt Hanson
Controls and Dynamics Branch
NASA Armstrong Flight Research Center
curtis.e.hanson@nasa.gov
661.276.3966

Chris Miller *NASA Armstrong Flight Research Center*

John H. Wall *Dynamic Concepts, Inc.*

Tannen S. VanZwieten *NASA Marshall Space Flight Center*

Eric Gilligan *NASA Marshall Space Flight Center*

Jeb S. Orr *The Charles Stark Draper Laboratory, Inc.*



Launch Vehicle Adaptive Control Flight Experiment Team



NASA Marshall Team

Eric Gilligan

Jeb Orr

John Wall

Tannen VanZwieten

NASA Armstrong Controls Team*

Curt Hanson

Chris Miller

*Significant support provided by AFRC outside of the controls team

NESC Engineering Team

Neil Dennehy

Ken Lebsock

Steven Gentz

Vicki Regenie

Jim Stewart

NASA Funding Partnerships:

- NASA Engineering and Safety Center
- Space Launch System (Marshall)
- Space Technology Mission Directorate – Game Changing Development Program



SLS Adaptive Augmenting Control



- ◆ Inclusion of the MSFC-developed adaptive augmenting controller is the current baseline for the SLS autopilot design
- ◆ The SLS Adaptive Augmenting Control (AAC) provides additional robustness by using sensed data to adjust the **gain** on-line

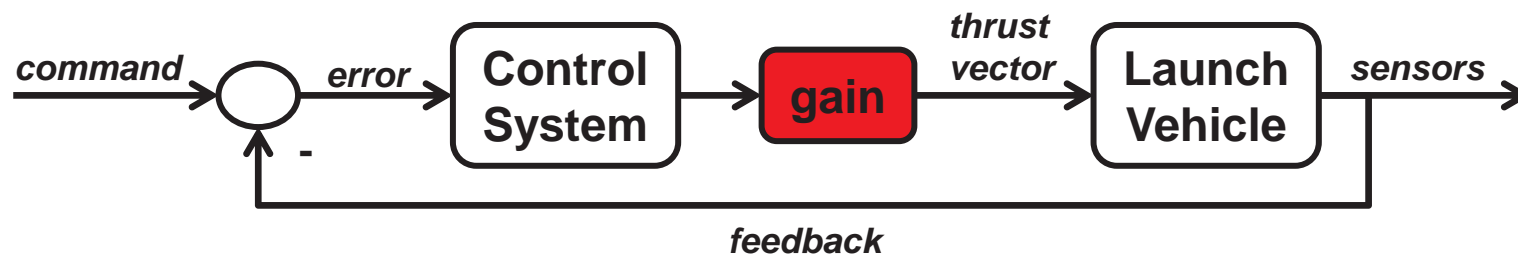

- ◆ AAC has three summary-level design objectives:
 1. “Do no harm”; return to classic control design when adaptation is not needed
 2. Increase responsiveness to recover pointing error within ability of vehicle control
 3. Reduce responsiveness to mitigate effects of undesirable interaction with internal dynamics (i.e., control-structure interaction)

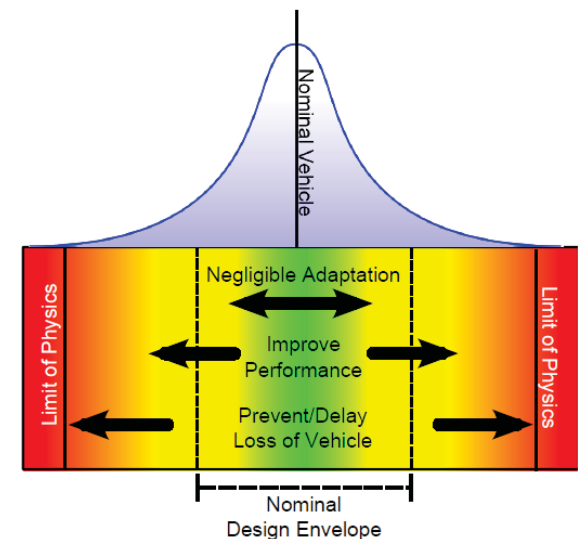

AAC Algorithm Design Paradigm:
Adapt on an As-needed Basis

- ◆ AAC had been the only part of the SLS autopilot lacking a flight test



Key Flight Characteristics



Development, Integration & Testing on F/A-18

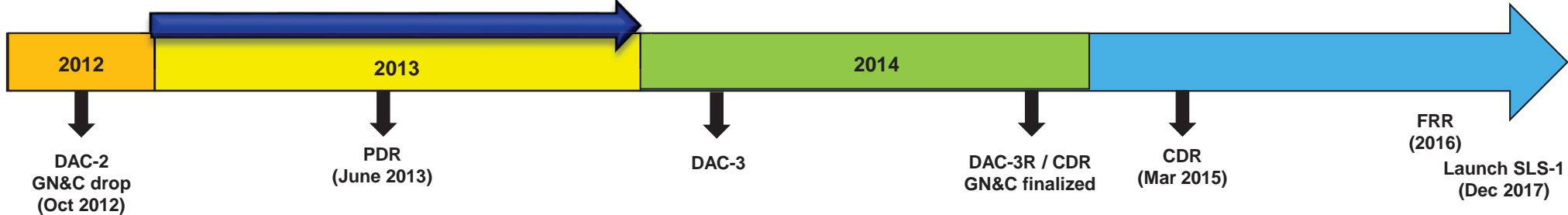

- ◆ ATP to completion of research flights in 1 year
- ◆ The SLS production flight software prototype (source code) was executed for this experiment

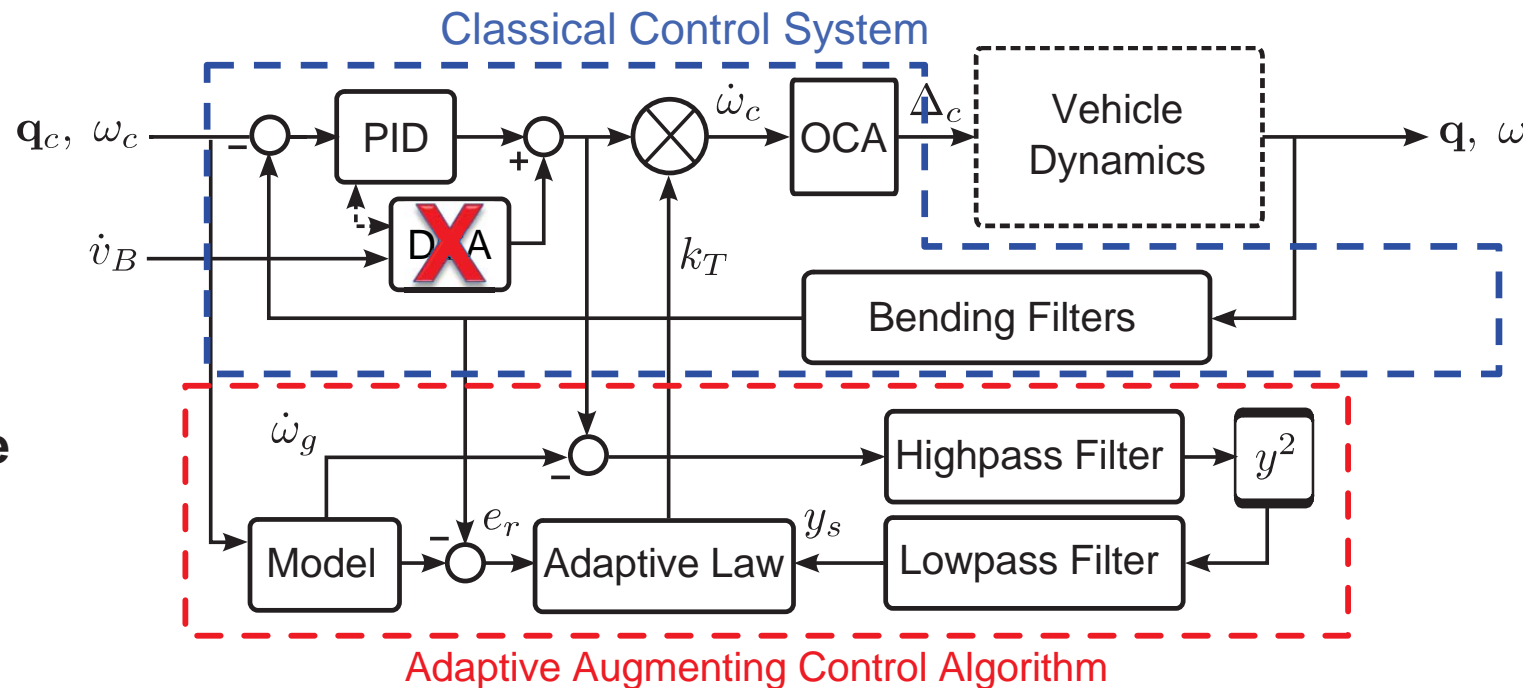

- ◆ Disturbance compensation algorithm was disabled; all other components remained active with identical parameter sets



Key Flight Characteristics



- ◆ Launch vehicle-like maneuver profile (F/A-18 matches SLS pitch rates)
- ◆ Armstrong's Nonlinear Dynamic Inversion (NDI) Controller allowed the F/A-18 to mimic the SLS pitch error dynamics

- ◆ SLS FCS engaged for ~70 sec

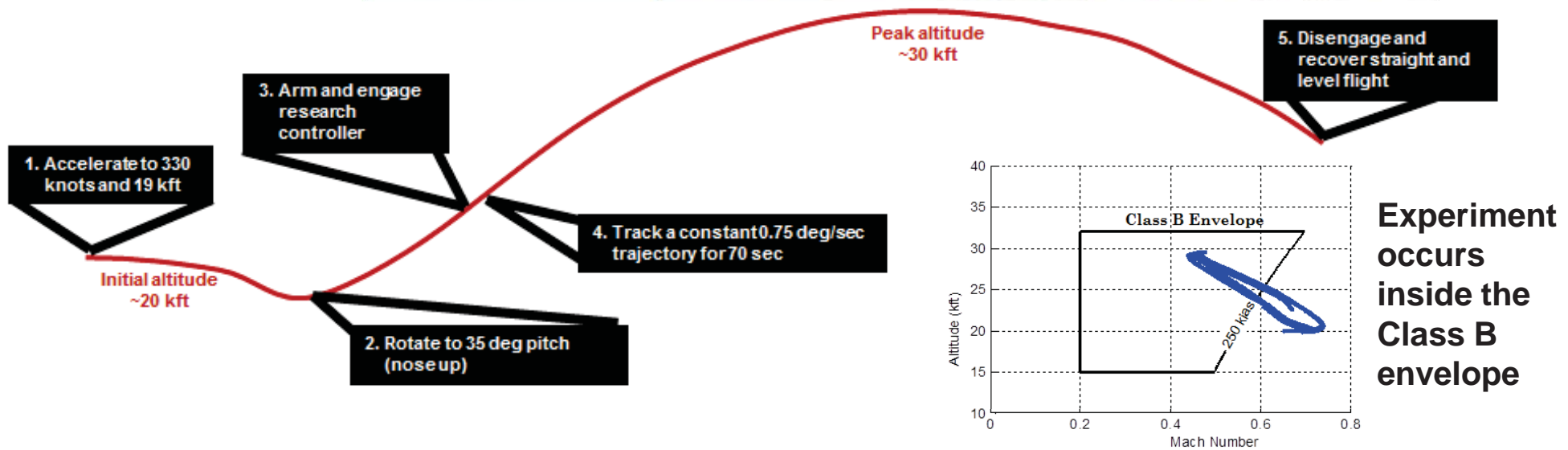

- ◆ Approx. 100 SLS-like trajectories were completed on the F/A-18 to fully characterize the algorithm performance and increase confidence that AAC is ready for deployment on SLS



Flight Test: Objectives & Summary



- ◆ Multiple test cases (potential SLS scenarios) mapped into each flight test objective; all were successfully & repeatedly met

Objective 1: Minimal adaptation for near-nominal cases

Objective 2: Increase responsiveness

Objective 3: Mitigate unstable mis-modeled internal dynamics

Objective 4: Manual steering & AAC – explore interactions

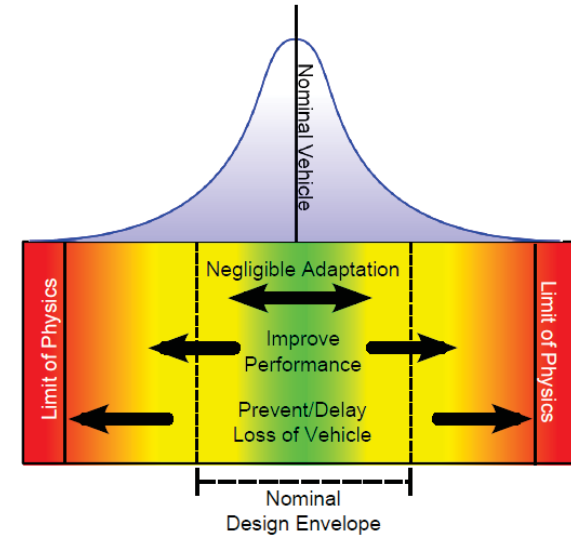

*algorithm
design
objectives*

- ◆ Summary of research flights

First Campaign: 14-15 Nov. 2013

- 45 SLS-like trajectories (autopilot mode)
- F/A-18 structural mode identification test

Second Campaign: 11-12 Dec. 2013

- Excite F/A-18 structural mode
 - Mitigate closed loop instability using AAC
- 40 SLS-like trajectories
 - Explore interactions between SLS manual steering mode and AAC
 - Repeat SLS scenarios that exhibited in-flight variability





Motivation to Test Manual Steering



- ◆ **Manual steering is a human-in-the-loop attitude control mode under consideration for the SLS.**
- ◆ **Launch Vehicle Adaptive Control (LVAC) Experiment Objectives:**
 1. Demonstrate closed-loop tracking with negligible adaptation in an environment that is commensurate with the nominal controller design.
 2. Demonstrate improved performance in an environment where the nominal controller performance is less than desired.
 3. Demonstrate the ability to recover from unstable, mis-modeled parasitic dynamics to a bounded nondestructive limit cycle.
 4. Explore interactions between manual steering and the AAC.
- ◆ **At the time of the LVAC flights,**
 - there was an SLS requirement for manual steering capability, but
 - there was no official manual steering mode design for SLS.
- ◆ **In-flight pilot evaluation of deficiencies and/or adverse Pilot-AAC interactions could:**
 - inform design choices in the SLS manual steering mode, and/or
 - restrict simultaneous use of AAC and manual steering.

Note: The LVAC flights addressed the SLS launch trajectory prior to SRB separation, while the SLS manual steering requirement applies to post-SRB separation.



LVAC Manual Steering Mode Implementation



Prototype Design

- ◆ No official SLS manual steering design existed at the time of the experiment
- ◆ The test team implemented a simple design based on assumed requirements

Re-located ADI gage near HUD to display pitch rate error using ILS needles.

Nose-wheel steering button initiates manual steering mode

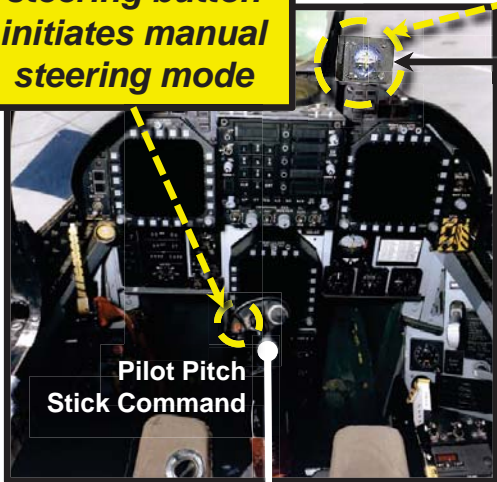

Pilot Pitch Stick Command

1 inch stick displacement equals 1 deg/s pitch rate

-0.75 deg/s
Approximate average pitch rate during SLS gravity turn prior to SRB separation

Control Strategy

- ◆ Single axis SLS control laws (pitch)
- ◆ Pilot steering commands replace SLS autopilot guidance commands
- ◆ Pilot throttle control for speed modulation
- ◆ NDI contains a wings-leveling loop

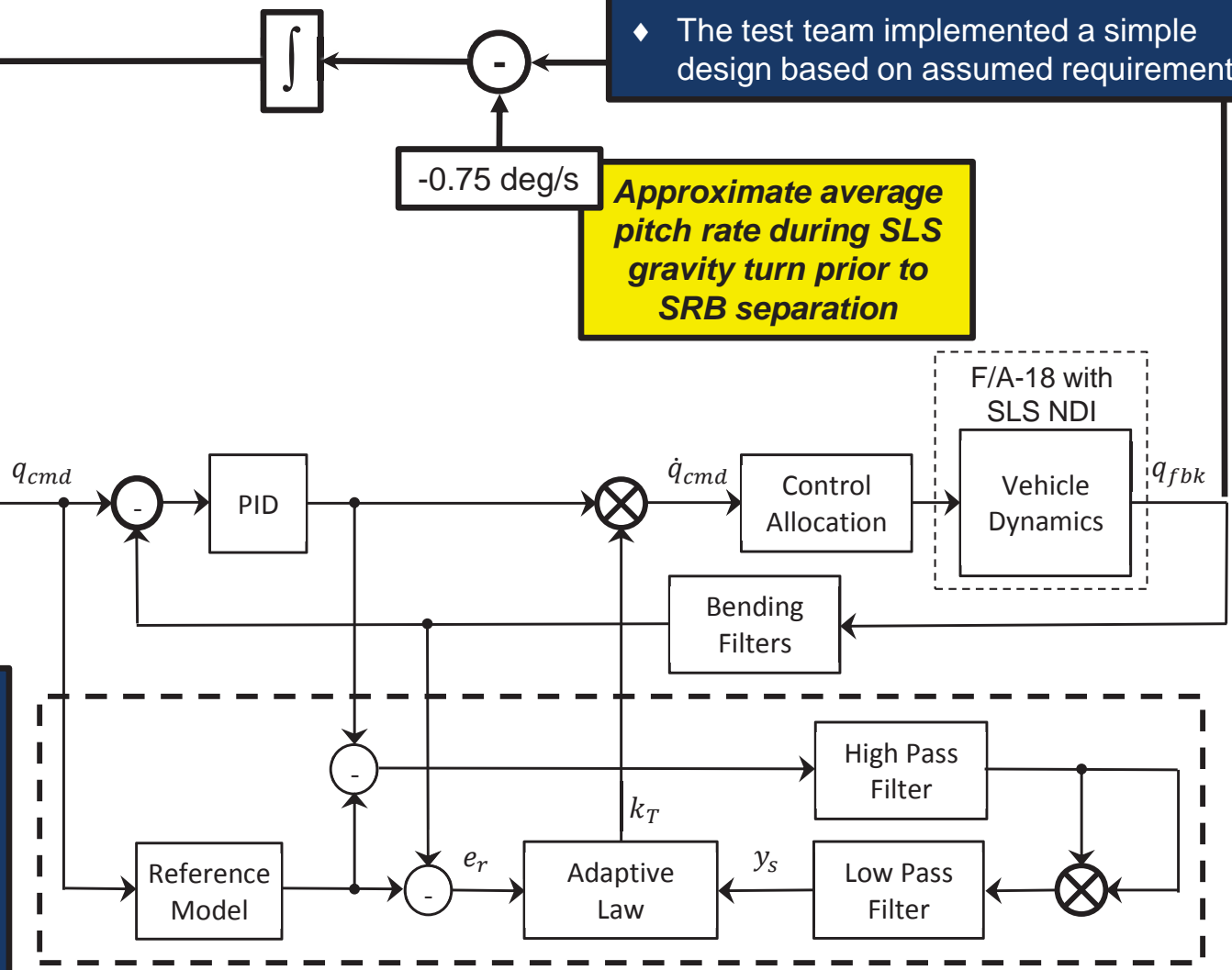

Adaptive Augmenting Control Algorithm



Sources of Adverse Pilot-AAC Interaction



Two adaptive gains in the pitch rate error loop

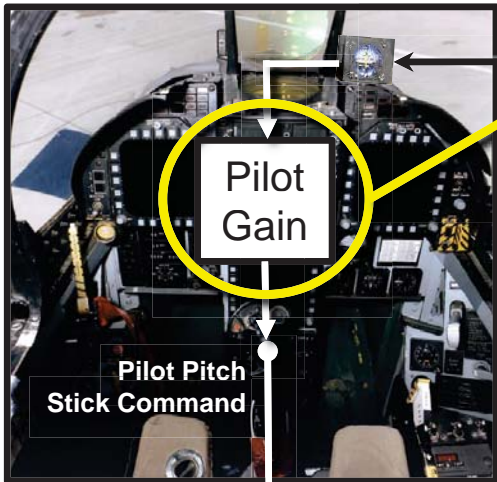

The pilot is an additional source of energy within the parasitic dynamics frequency band

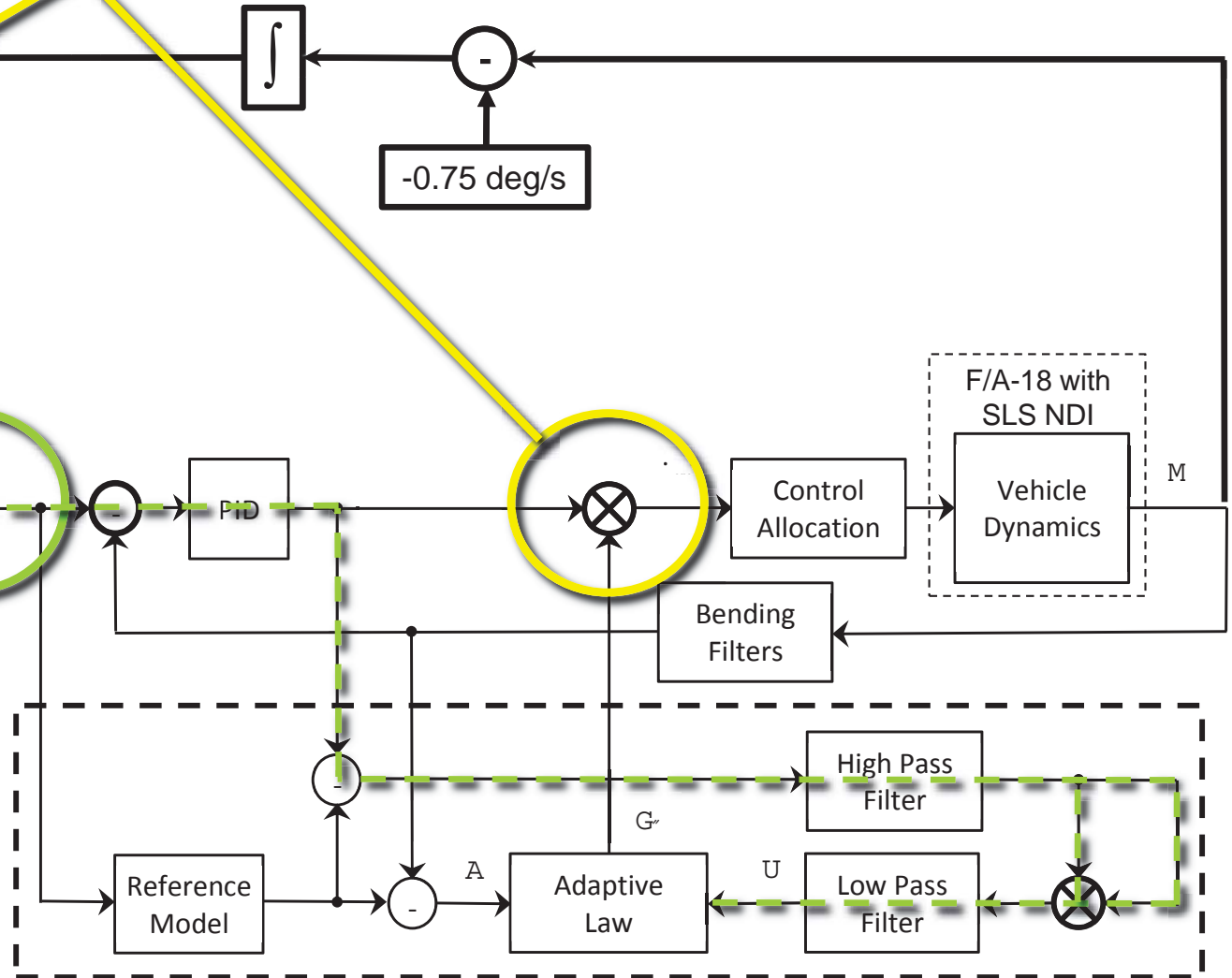

Adaptive Augmenting Control Algorithm



Test Approach



◆ Two pilots, 25 test trajectories, 6 test scenarios

- Pilot A: 13 trajectories, 5 scenarios / Pilot B: 12 trajectories, 5 scenarios
- Back-to-back evaluations, AAC Off vs. On, for each scenario
- Nominal case flown at the beginning and end of each flight
- Pilot hot-mic comments and HUD video recorded during and immediately following each test point, along with Pilot Involved Oscillation (PIO) ratings

Objective	Case	SLS Scenario Description	AAC	Pilot A (number of attempts)	Pilot B (number of attempts)
1	0	Nominal Plant and Environment	on	2	2
			off	2	2
2	5	Two-Spaced Hard-Over Failures	off	1	1
			on	1	1
	7	Wind Shear, Two Hard-Over Failures	off	1	1
			on	2	1
3	15	High Gain plus Slosh Excitation	off	0	1
			on	0	1
	16	High Gain with Unstable Flex	off	1	0
			on	1	0
	17	High Gain plus Rigid Body Instability	off	1	1
			on	1	1

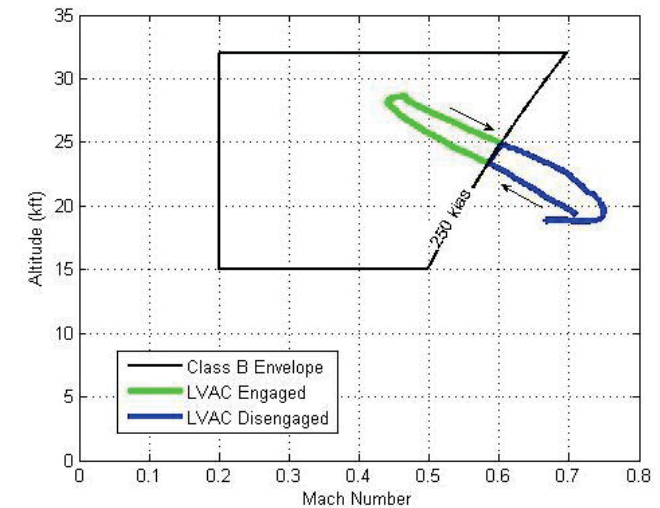



Pilot-AAC interaction Evaluation Metrics



◆ Cumulative Tracking Error

- Integral of the square of the pitch attitude tracking error vs. time.
- Metric for evaluating Objectives 1 and 2

◆ PIO Rating Scale

- From MIL-STD-1797B, Flying Qualities of Piloted Aircraft, Feb. 15, 2006
- Qualitative and quantitative measure of tendency to instability resulting from pilot attempts to control the vehicle (Pilot Involved Oscillations)

◆ Pilot Workload Metrics

- Cross-plot of Duty Cycle vs. Aggressiveness
 - Duty Cycle: frequency with which the pilot reverses control direction
 - Aggressiveness: measure of dynamic control inceptor deflection

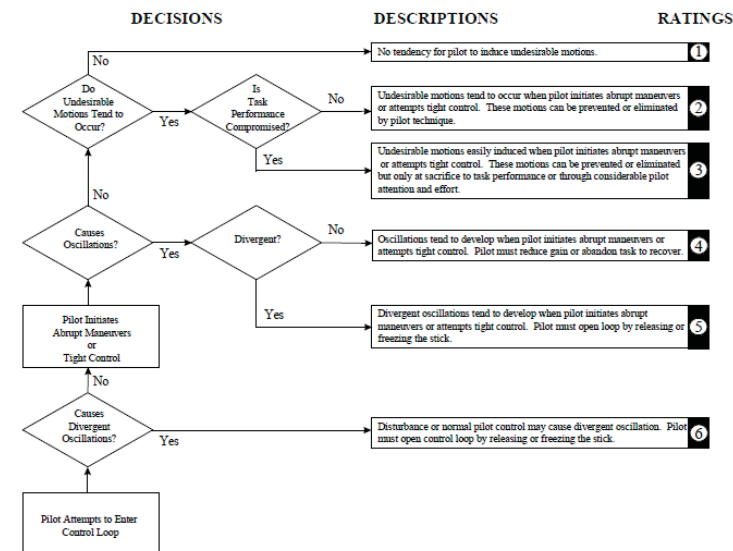
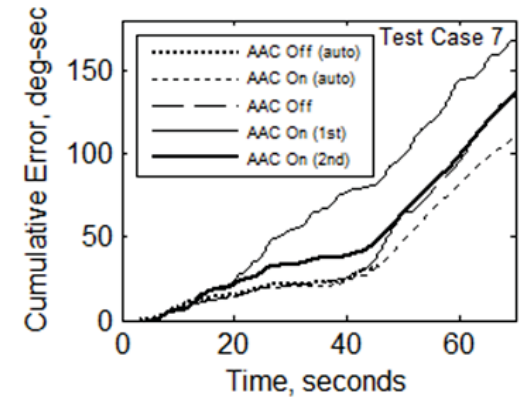

$$J_A = \frac{100\%}{t_f - t_0} \sum_{\tau=t_0}^{t_f} \left(\frac{|q_{cmd}(\tau) - \bar{q}_{cmd}(\tau)|}{q_{cmd}^{max} - q_{cmd}^{min}} \right) \Delta\tau$$



Top-Level PIO Ratings Summary



AAC increased PIO tendency for Objectives 1 and 2 (small effect)

AAC reduced PIO tendency for Objective 3 (large effect)

Pilot A / Test Case 0 / AAC Off
1st Attempt – “Any attempt to tighten control leads to PIO. Task performance is affected, but with a lot of compensation I can make this work.” (PIO rating 5)

2nd Attempt – “Tight control definitely causes oscillations - they’re not necessarily divergent - somewhat open-loop task.” (PIO rating 3)

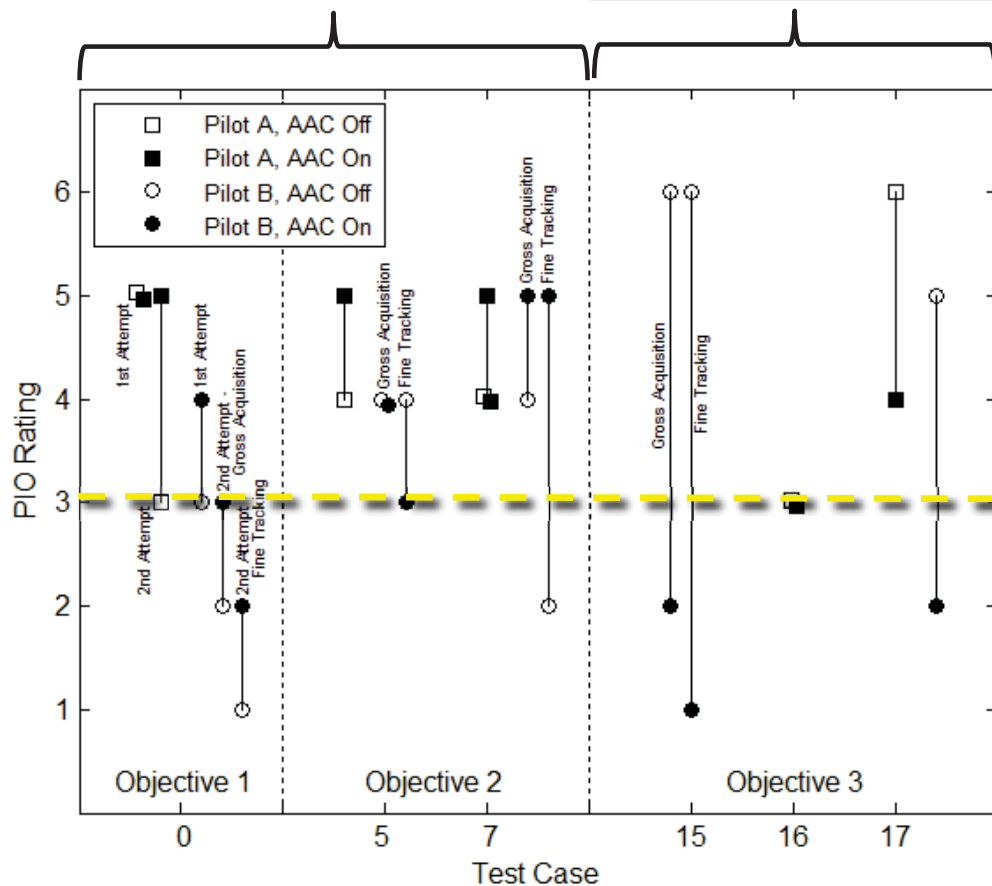

~80% of test points rated as “Task Performance Compromised” or worse

The SLS in manual steering mode* is very PIO-prone, with or without AAC.

* This experiment did not evaluate any official SLS manual steering mode designs.



Objective 1: Minimal Adaptation in the Nominal Case



Test Case 0: Nominal Plant and Environment

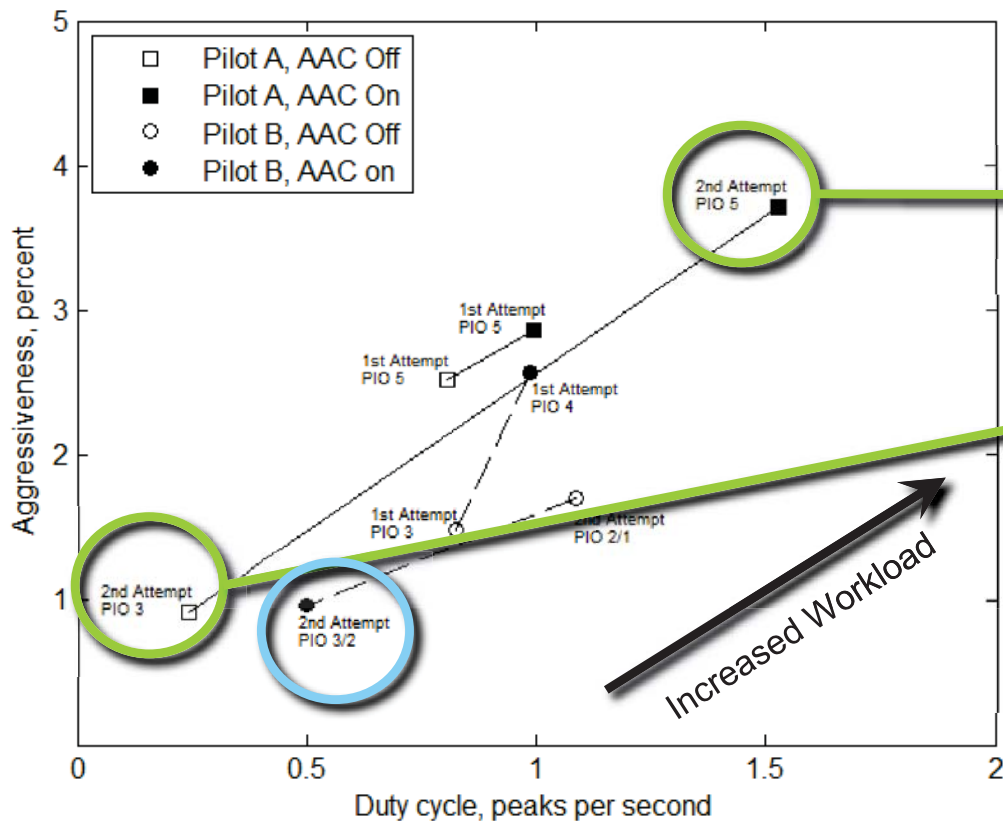

Pilot A – 2nd Attempt
 Much higher workload and reduced tracking performance with AAC.

Pilot B – 2nd Attempt
 Reduced workload and little change in tracking performance with AAC.

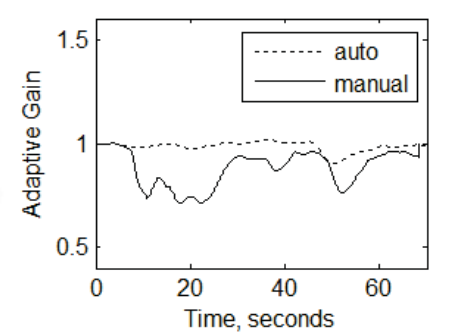
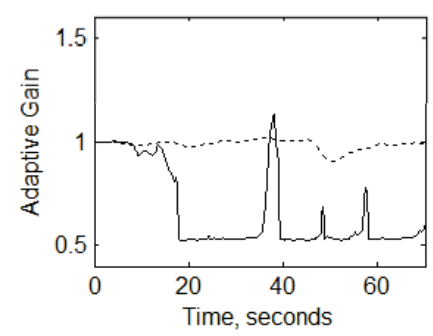
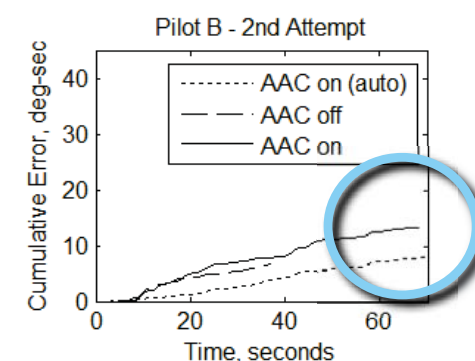
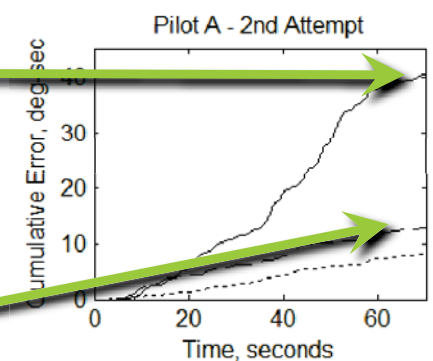

In 3 of 4 attempts, adaptation increased pilot workload.

In all cases, adaptation resulted in the same or worse PIO rating.

With manual steering, the adaptive gain is at or near its lower limit for much of the maneuver.

The adaptive gain with manual steering remains near the nominal value of 1, similar to the autopilot.



Objective 1: Minimal Adaptation in the Nominal Case



Pilot-AAC Adverse Interaction

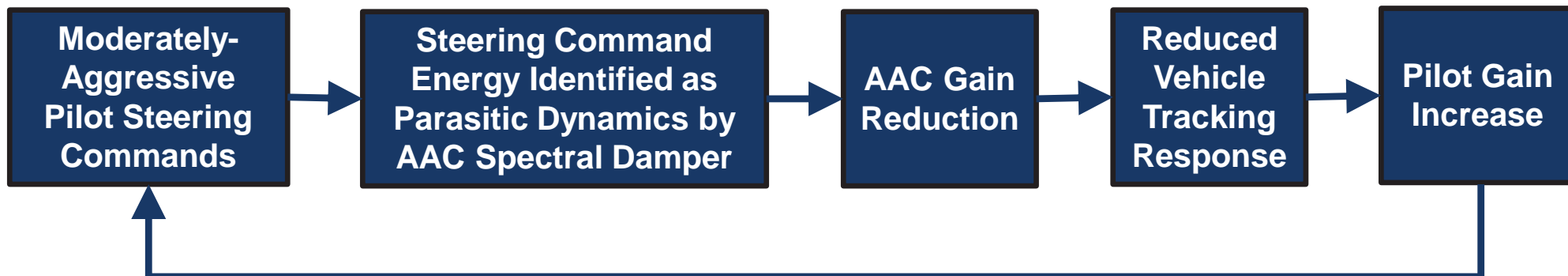

Pilot A – 2nd Attempt

With AAC On, the pilot's manual steering inputs were interpreted as parasitic dynamics by the spectral damper component of the adaptive law, driving the gain lower. The pilot had to increase his gain to compensate, causing the pilot and AAC to enter into an adverse interaction.

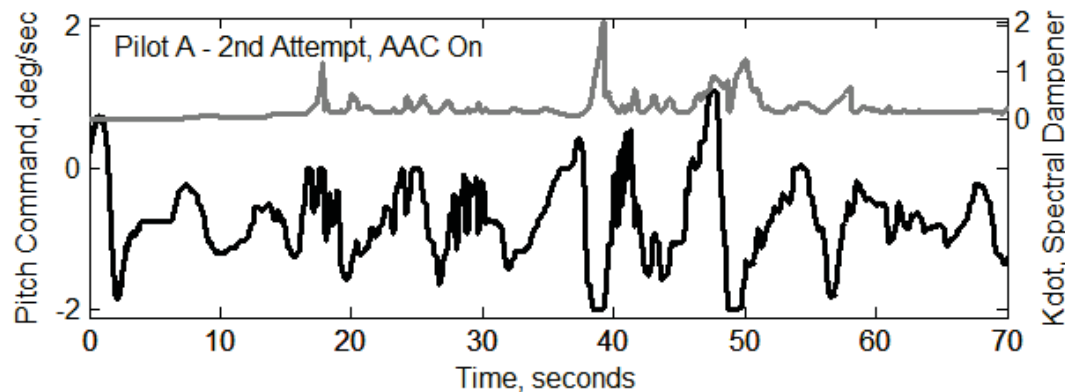

Pilot B – 2nd Attempt

In this case, the pilot's commands were of a low enough frequency to avoid detection by the spectral damper, and did not affect the adaptive gain.

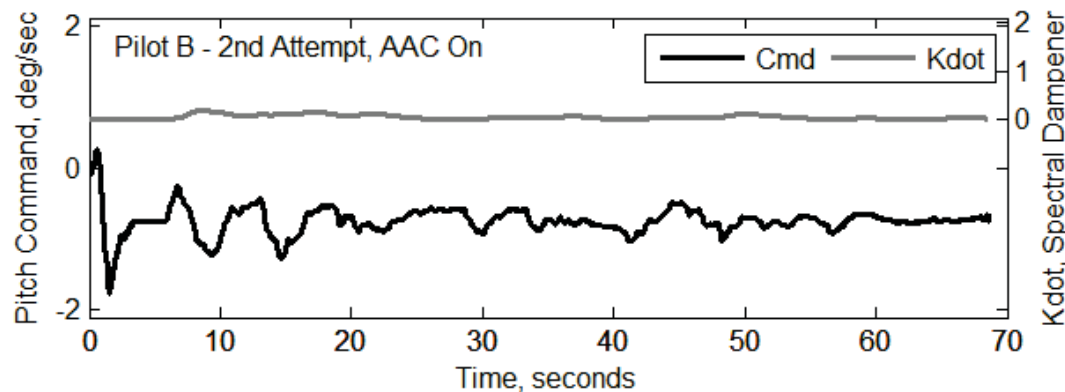



Summary



- ◆ **Manual steering* did not improve performance or robustness beyond what could be achieved using just the AAC algorithm.**
- ◆ **Scenarios from all 3 Objectives showed a tendency for adverse interaction between the pilot and the adaptive controller.**
 - The use of manual steering tends to suppress the adaptive gain below its ideal value.
 - In many cases, the AAC increased pilot workload and tendency for PIO.
 - Beneficial interactions included cases where the fixed gain is too high, or where mis-modeled dynamics such as slosh create an increased likelihood of PIO without AAC.
- ◆ **Pilot technique can reduce the likelihood of adverse pilot-AAC interaction.**
 - Early in each flight, the pilots adjusted their approach from tight control to more of an open-loop task.
 - In an emergency situation, it may be difficult for the pilot to lower his/her gain and avoid attempts at tight control.
- ◆ **If manual steering is to be engaged, changes from the prototype design should be considered.**
 - Filtering of pilot inputs
 - Active modulation of inceptor feel system

* This experiment did not evaluate any official SLS manual steering mode designs.



Backup Slides



Components of SLS Adaptive Augmenting Control



Update Law

Adaptation rate

Error term

"Spectral damper"

Leakage

$$\dot{k}_T = p_{hi}(k_T) a e_r^2 - p_{lo}(k_T) \alpha y_s - \beta(k_T - 1)$$

2. Increased Response

3. Decreased Response

1. Attract to Nominal

- ◆ (1) No adaptation when not needed
 - Unforced solution returns to equilibrium state (unity gain)

Stay the course

- ◆ (2) Increased response driven by reference model error

- Simple onboard math model indicates expected launch vehicle motion
- Model compared with actual motion produces error, and increases control system response

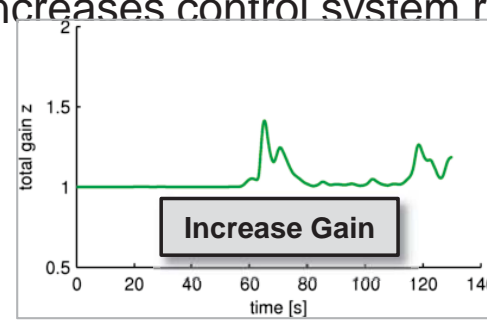
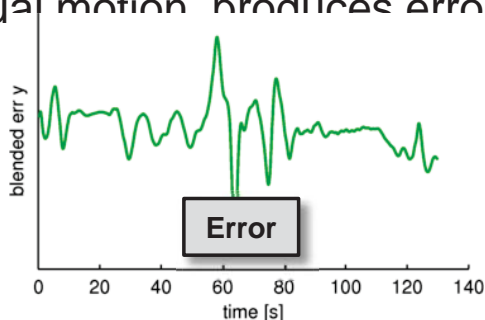
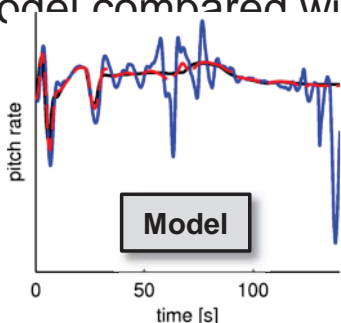

Increase Gain

- ◆ (3) Decreased response driven by spectral damper power estimator

- Measures thrust vector activity in specific frequency band
- Produces a "power" signal to effect decrease system response

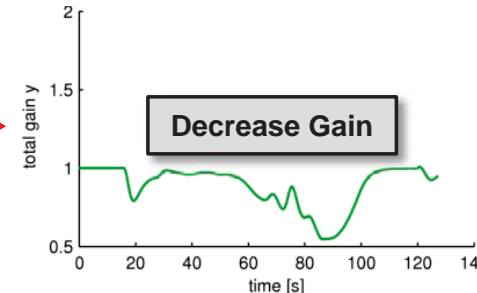
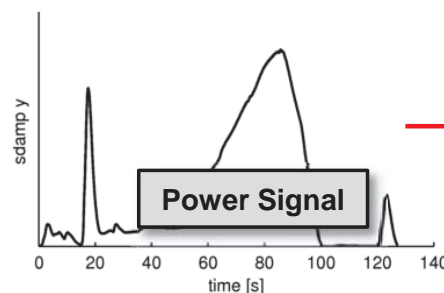
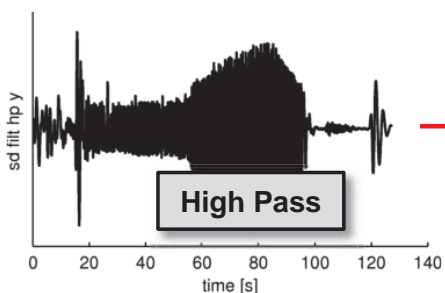
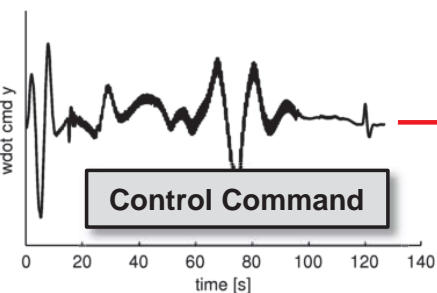

Decrease Gain



Motivation for Flight Testing

- ◆ Inclusion of Adaptive Augmenting Control (AAC) in the SLS autopilot design is the current baseline
 - Active for official DAC-2, PDR, and DAC-3 results
- ◆ AAC was the only part of the SLS autopilot lacking a flight test

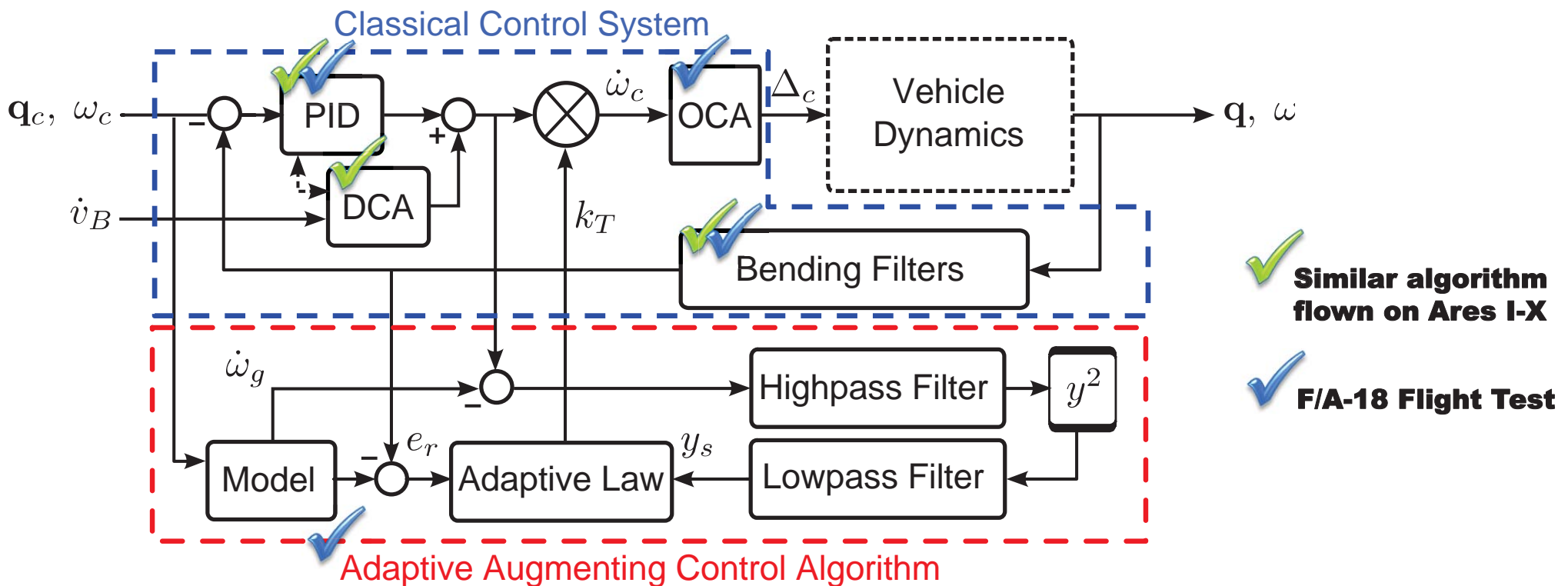

- ◆ F/A-18 flight characterization experiment increases confidence in AAC through
 - Characterization of the algorithm on a large-scale, manned flight test platform
 - Software V&V of the full-scale algorithm
 - Advancement of the technology readiness early in the program



F/A-18 + NDI → “Looks Like” SLS



- ◆ Armstrong previously developed a Nonlinear Dynamic Inversion (NDI) Controller on an F/A-18 which allows the aircraft to mimic dynamics of other aircraft/systems
- ◆ F/A-18 NDI effectively “slows down” natural fighter jet to act like the SLS launch vehicle
- ◆ SLS production control system installed on F/A-18, thinks its flying SLS
- ◆ For SLS, experiment isolated to a single axis: pitch



=

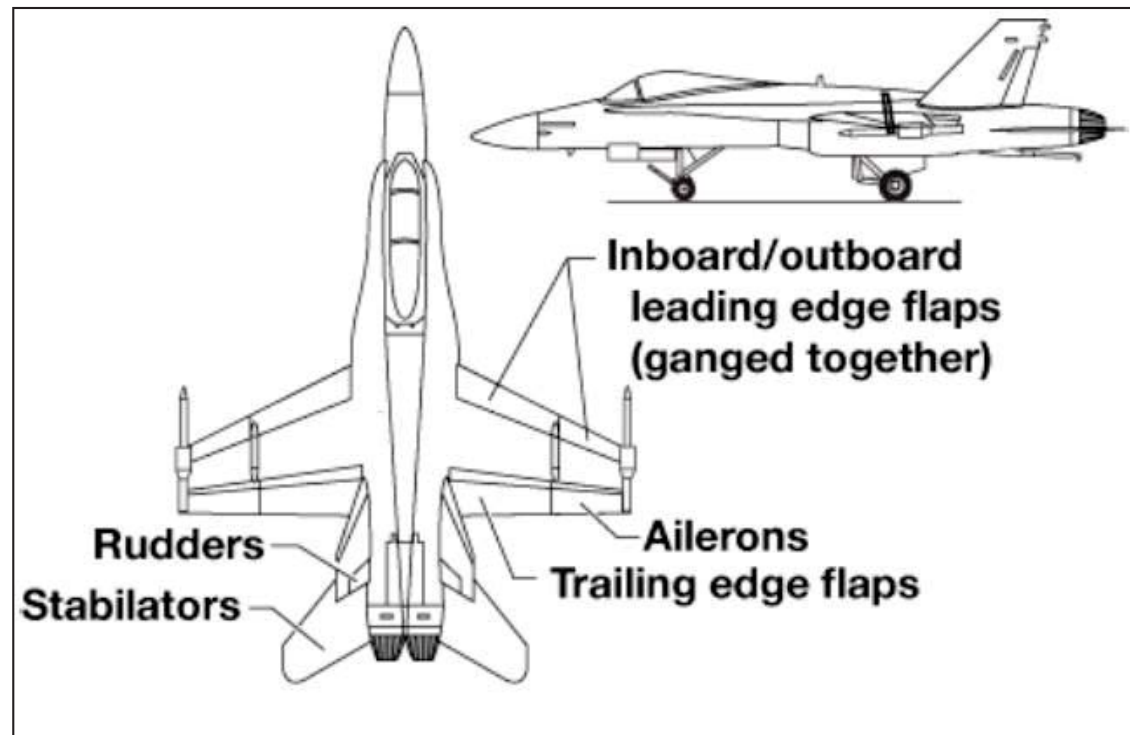



Test Cases



- ◆ Each scenario was completed with AAC on and AAC off in series

Objective 1: Minimal Adaptation

M – manual steering; A – autopilot

TC	Description of SLS Scenario	FT1	FT2	FT3	FT4	FT5
0	Nominal Plant, environment & controller	A	A		MM	MM
1	Heavy/slow vehicle			A		
2	Light/fast vehicle			A		

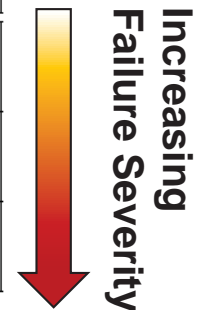

Objective 2: Improved Tracking Performance

TC	Description of SLS Scenario	FT1	FT2	FT3	FT4	FT5
3	Wind shear event		A			
4	Thrust vector control bias		A			
5	Hardover failure of 2 core engines (offset in time)		A		M	M
6	Heavy/slow, wind shear, SRB tailoff thrust imbalance			A		
7	Wind shear event and double hardover failure		A		M	M
14	Low-gain controller, wind shear, 2 hardover failures		A			

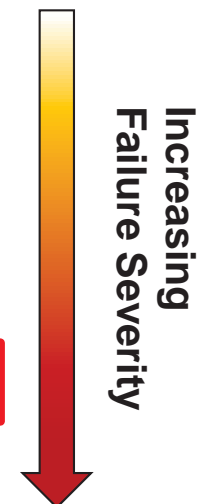



Example Test Case for Objective 2



Objective 2: Improved Tracking Performance

Test Case 7 Description

- Increase in aerodynamic instability
- Wind shear event
- Double core engine hardover failure

Results

- Excellent matching across simulations and flight test results
- AAC off: Simulated Loss of Vehicle (LOV) occurs
- AAC on: Total control increases to recover stability

HILS – Armstrong’s Hardware-In-the-Loop

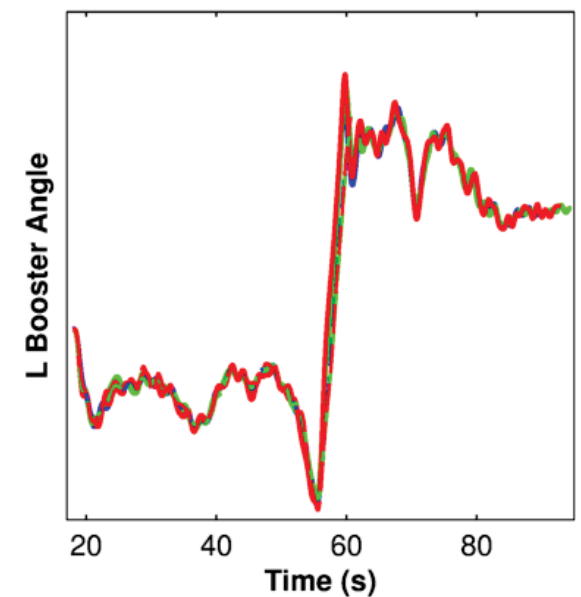
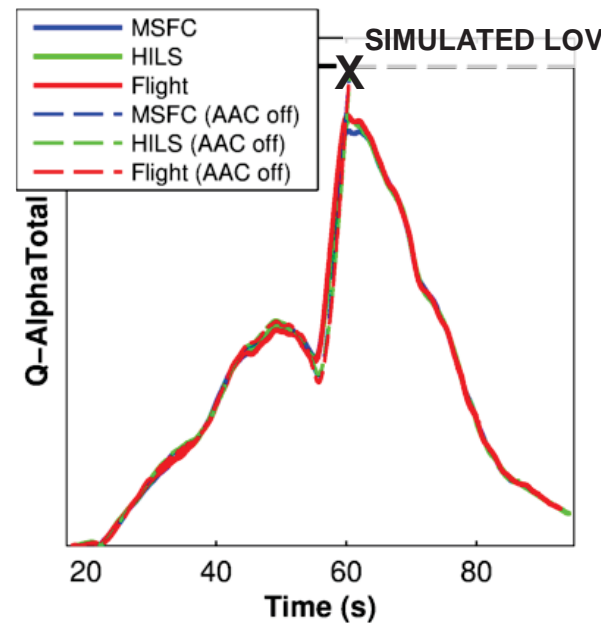
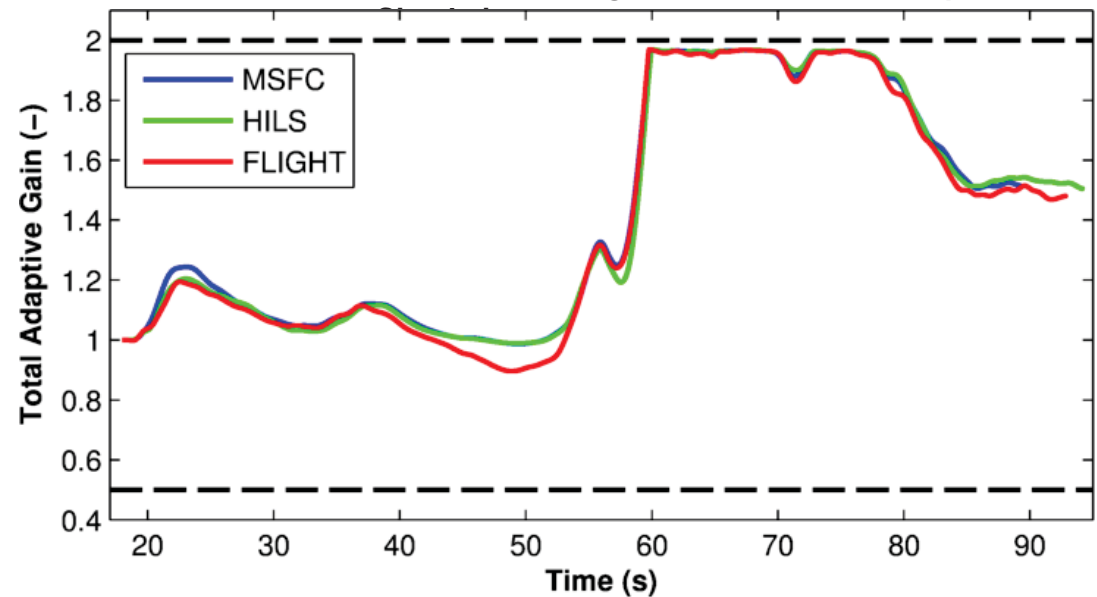



Test Cases



Objective 3: Restrict Unstable Mis-Modeled Internal Dynamics to a Bounded Non-Destructive Limit Cycle

TC	Description of SLS Scenario	FT1	FT2	FT3	FT4	FT5
9	Light/fast with slosh instability		A	A		
10	Structural instability		A	A		
15	High-gain controller, slosh instability		A	A		
16	High-gain controller, unstable flex		A	A	MAA	MAA
17	High-gain controller, rigid body instability		A	A	MAA	MAA
20	F/A-18 Structural Mode	ID			S/L	S/L
22	F/A-18 Structural Mode with EGI	ID			S/L	S/L

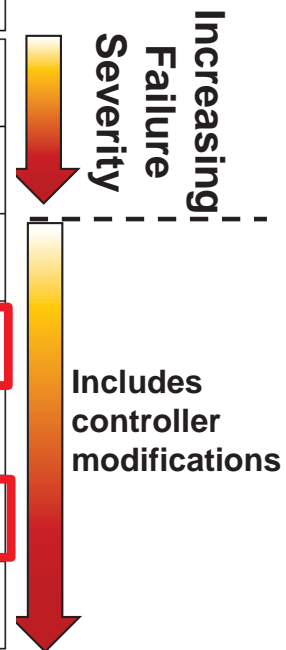



Example Test Case for Objective 3

Objective 3: Mitigate Unstable Mis-Modeled Internal Dynamics

Test Case 16 Description

- High controller gain
- Simulated unstable SLS flex mode
- Flex dynamics applied to the aircraft via the ailerons
- Alternate effectors (primarily stabilators) implemented the FCS commands

Results

- Increase in aileron effectiveness resulted in a larger amplitude instability during flight
- AAC off: Vehicle exceeds structural load limit, resulting in a simulated LOV
- AAC on: total control gain decreases to recover stability (simulation) or delay LOV (flight)

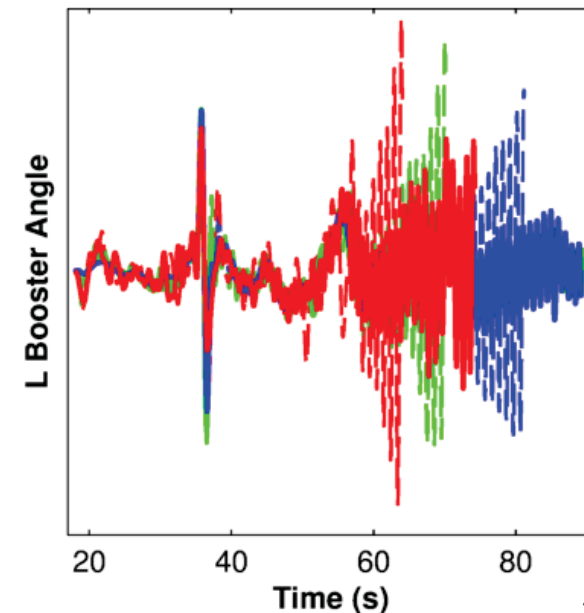
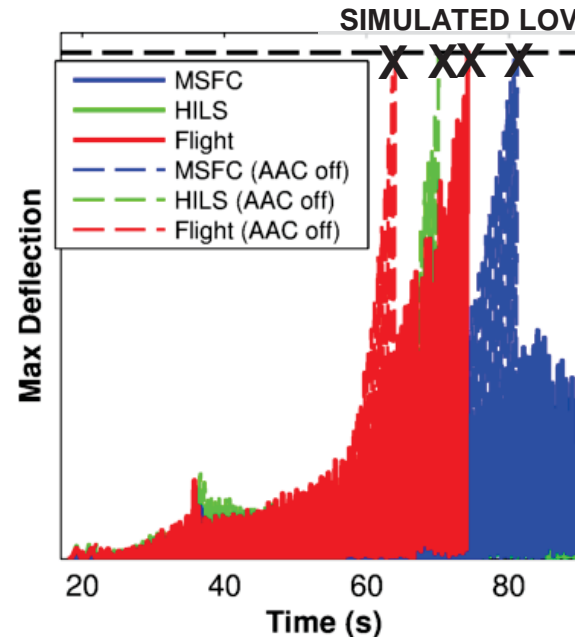
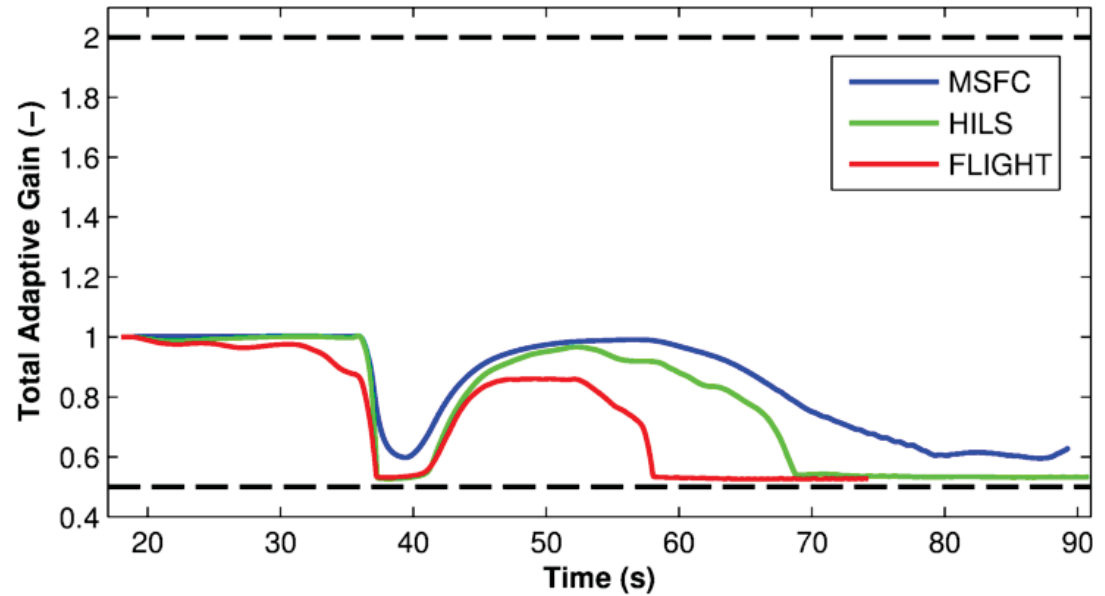



AAC Suppresses F/A-18 Mode of Vibration



Objective 3: Mitigate Unstable Mis-Modeled Internal Dynamics

F/A-18 Structural Mode Identification – Reconstruction based on a 60 sec PTI input

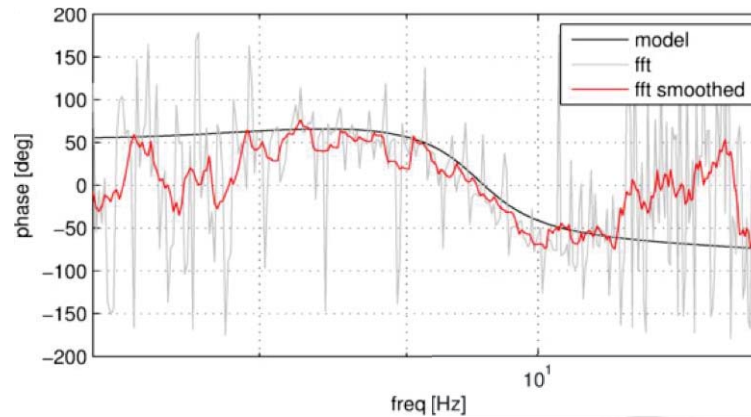
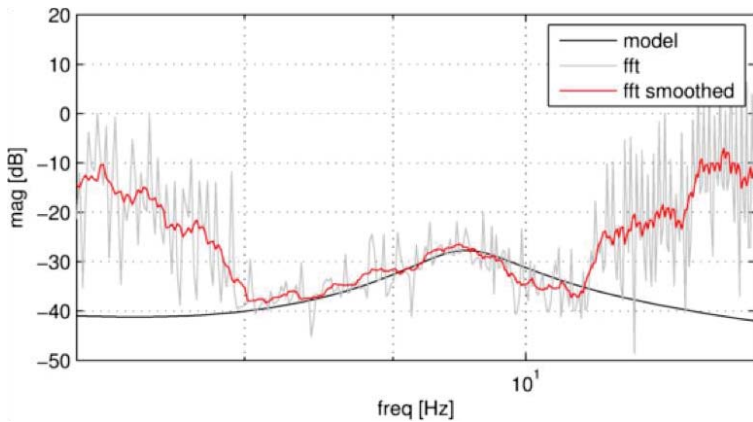

AAC Mitigates Unstable Airframe Mode

- F/A-18 filters removed for this flight experiment
- SLS FCS filter phase / amplitude adjusted to create a closed loop instability

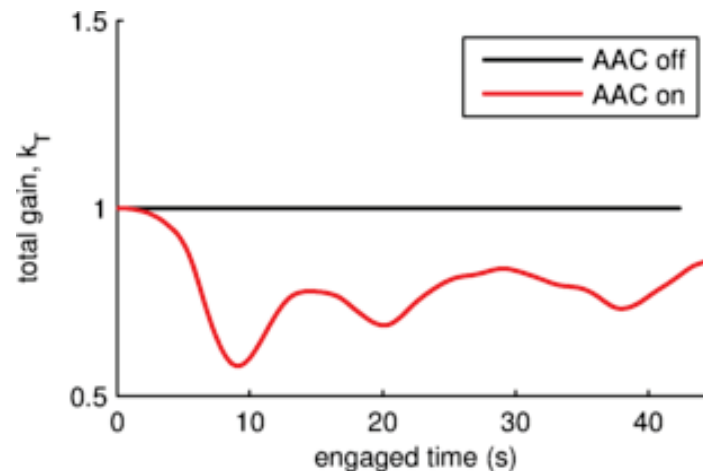
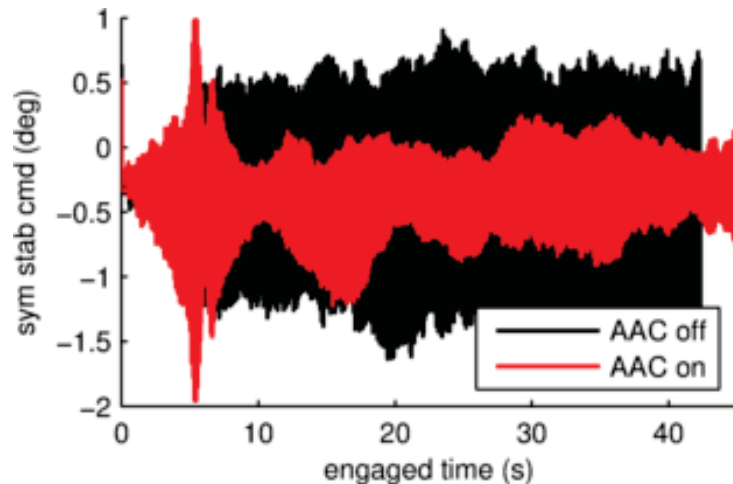



Objective 2: Improved Tracking Performance



Test Case 7: Wind shear and two simultaneous hard-over failures

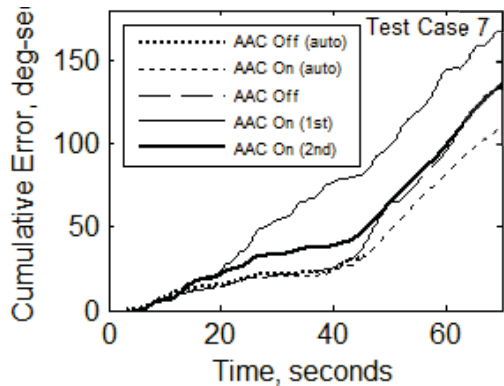

Difference in tracking error, attempt #1 vs. #2

Two back-to-back attempts by Pilot A show the effects of pilot technique on adverse interaction with the adaptive controller.

On attempt #1, large adaptive gain oscillations

On attempt #2, similar gain behavior to the autopilot case

Pilot A / Test Case 7 / AAC On: 1st Attempt
“Getting into an oscillation. Seems divergent. I seem to have recovered somewhat. Any real attempt to do the task leads to pretty good oscillations that seem divergent.” (PIO rating 5)

Pilot A / Test Case 7 / AAC On” 2nd Attempt
“If I’m really careful, I can sort of track this. It’s very sensitive. I changed my piloting technique a lot and didn’t really attempt tight control.” (PIO rating 3)

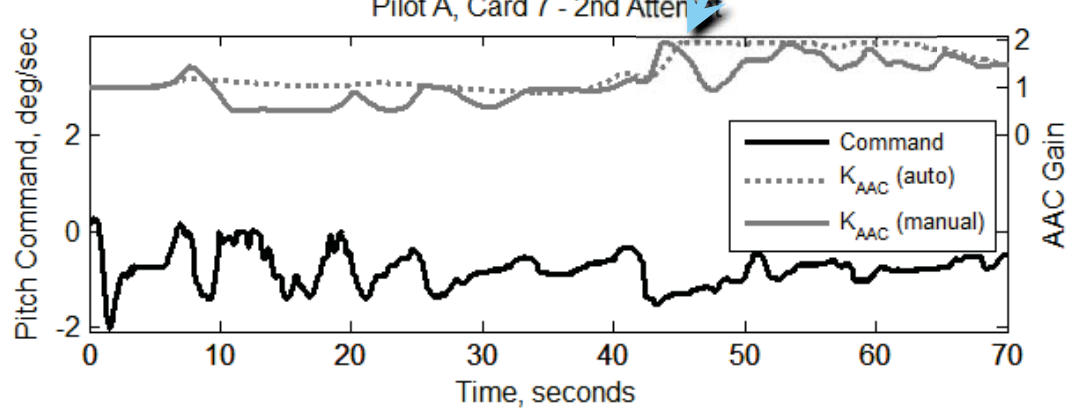
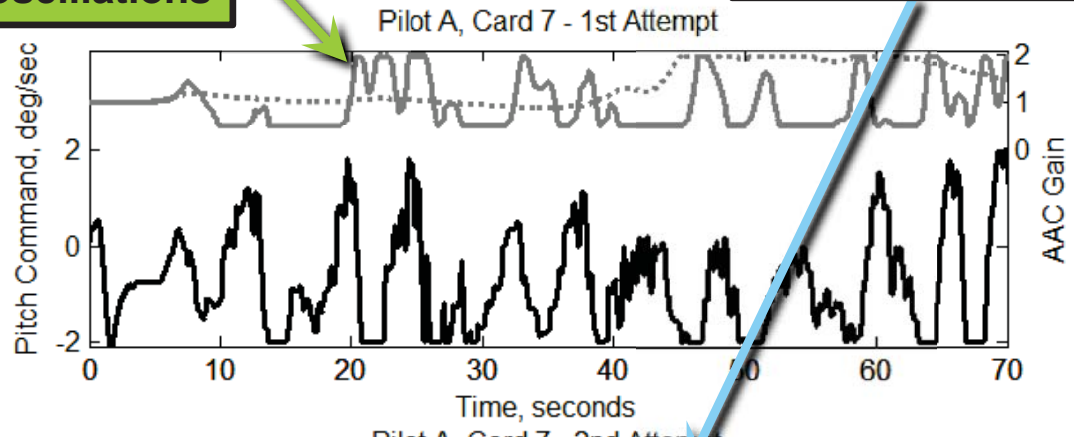



Objective 3: Mis-Modeled Parasitic Dynamics



Test Case 15: High Gain Controller with Slosh, Pilot B

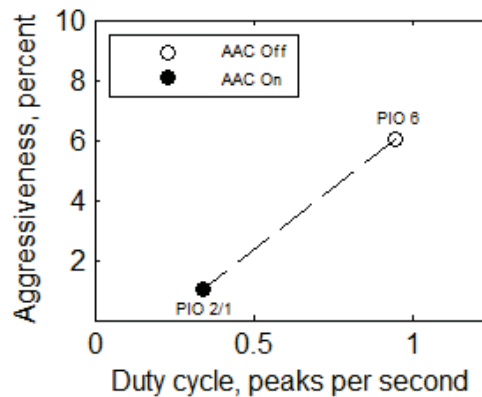
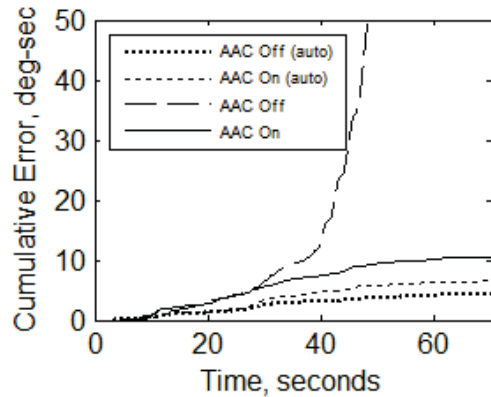

TC 15: Without AAC active, the pilot encountered a divergent PIO that resulted in simulated loss of vehicle.

Test Case 16: High Gain Controller with Unstable Flex, Pilot A

TC 16: Without AAC active, the pilot extended the trajectory by about 9 seconds over the autopilot.

With AAC on, manual steering had little effect on the loss of vehicle.

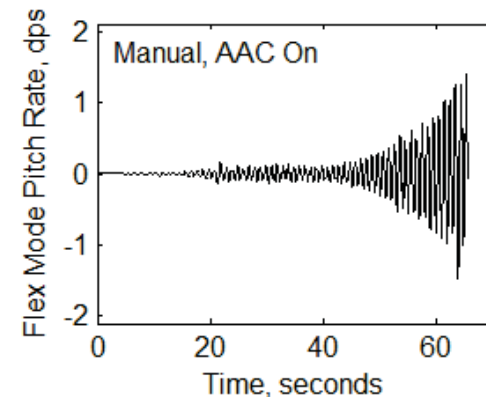
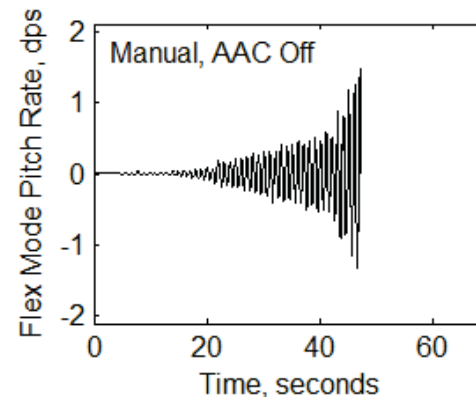
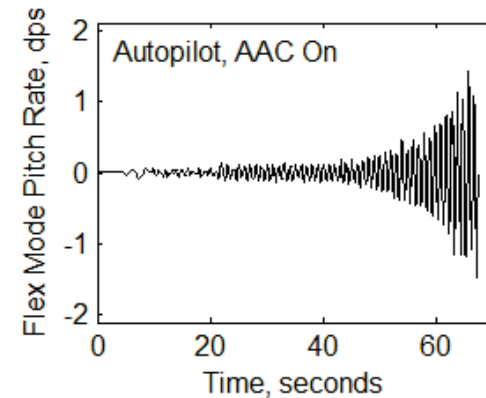
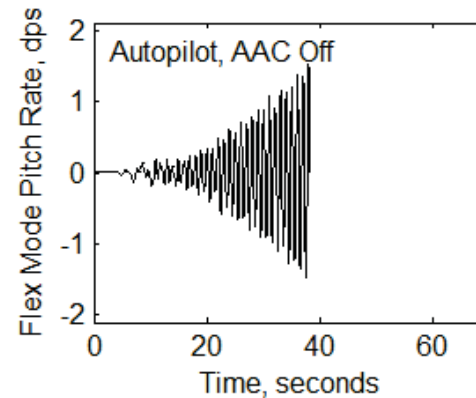



PIO Rating Scale

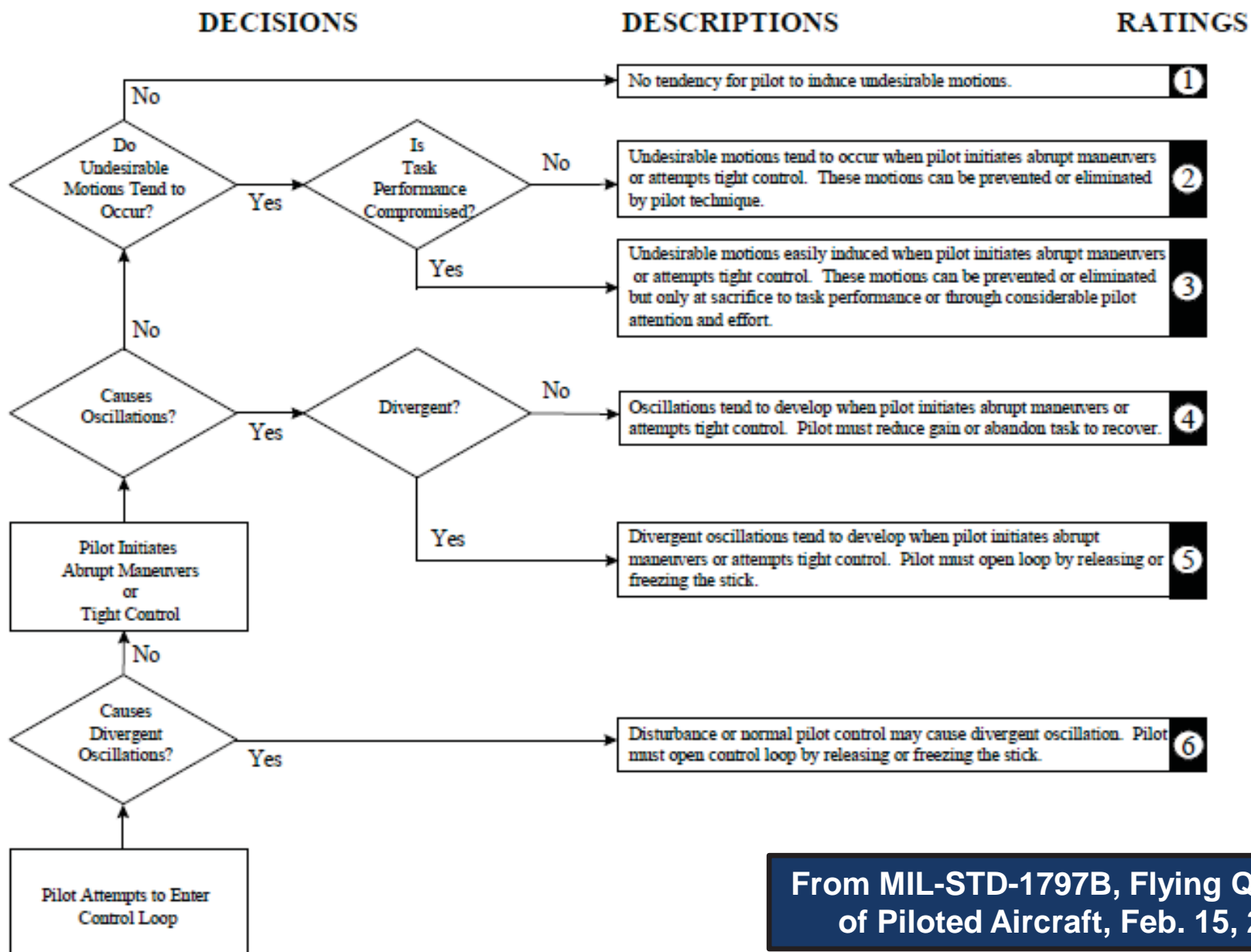

From MIL-STD-1797B, Flying Qualities of Piloted Aircraft, Feb. 15, 2006



Summary



- ◆ Inclusion of the MSFC-developed adaptive augmenting controller is the current baseline for the SLS autopilot design
- ◆ Armstrong's Full-Scale Advanced Systems Testbed (FAST) F/A-18 with nonlinear dynamic inversion capability provided an excellent platform for flight characterization experiments
- ◆ The SLS production flight software prototype (source code) was used for this experiment, including parameters, with only the disturbance compensation algorithm disabled
- ◆ Multiple flights and ~100 SLS-like trajectories were completed on the F/A-18 to fully characterize the algorithm performance and increase confidence that AAC is ready for deployment on SLS
- ◆ All flight test objectives – corresponding to AAC design objectives and an additional objective to assess pilot-in-the-loop interaction – were successfully and repeatedly met
- ◆ All research flights completed within a year of ATP