

Hyperspectral Microwave Atmospheric Sounder (HyMAS) - new capability in the CoSMIR/CoSSIR scanhead

Lawrence Hilliard, Paul Racette
NASA Goddard Space Flight Center
8800 Greenbelt Road
Greenbelt MD 20771
301-286-9294
Lawrence.M.Hilliard@NASA.gov
Paul.E.Racette@NASA.gov

William Blackwell, Christopher
Galbraith, Erik Thompson
MIT - Lincoln Laboratory
244 Wood Street
Lexington, MA 02420-9108
781-981-7973
wjb@ll.mit.edu
chris.galbraith@ll.mit.edu
Erik.Thompson@ll.mit.edu

Abstract— Lincoln Laboratory and NASA's Goddard Space Flight Center have teamed to re-use an existing instrument platform, the CoSMIR/CoSSIR system for atmospheric sounding, to develop a new capability in hyperspectral filtering, data collection, and display. The volume of the scanhead accommodated an intermediate frequency processor (IFP), that provides the filtering and digitization of the raw data and the interoperable remote component (IRC) adapted to CoSMIR, CoSSIR, and HyMAS that stores and archives the data with time tagged calibration and navigation data.

The first element of the work is the demonstration of a hyperspectral microwave receiver subsystem that was recently shown using a comprehensive simulation study to yield performance that substantially exceeds current state-of-the-art. Hyperspectral microwave sounders with ~100 channels offer temperature and humidity sounding improvements similar to those obtained when infrared sensors became hyperspectral, but with the relative insensitivity to clouds that characterizes microwave sensors. Hyperspectral microwave operation is achieved using independent RF antenna/receiver arrays that sample the same area/volume of the Earth's surface/atmosphere at slightly different frequencies and therefore synthesize a set of dense, finely spaced vertical weighting functions.

The second, enabling element of the proposal is the development of a compact 52-channel Intermediate Frequency processor module. A principal challenge in the development of a hyperspectral microwave system is the size of the IF filter bank required for channelization. Large bandwidths are simultaneously processed, thus complicating the use of digital back-ends with associated high complexities, costs, and power requirements. Our approach involves passive filters implemented using low-temperature co-fired ceramic (LTCC) technology to achieve an ultra-compact module that can be easily integrated with existing RF front-end technology. This IF processor is universally applicable to other microwave sensing missions requiring compact IF spectrometry.

The data include 52 operational channels with low IF module volume (<100cm³) and mass (<300g) and linearity better than 0.3% over a 330K dynamic range.

TABLE OF CONTENTS

1. INTRODUCTION	1
2. HYMAS DESCRIPTION	2
3. ANTENNA PERFORMANCE DATA	3
4. RECEIVER PERFORMANCE DATA	4
5. IFP PROTOTYPE PERFORMANCE	4
6. GRAPHICAL USER INTERFACE UPDATE	5
7. SUMMARY	6
REFERENCES	7
BIOGRAPHY	7

1. INTRODUCTION

The Hyperspectral Microwave Atmospheric Sounder (HyMAS) is an instrument concept with a mechanical scanner that takes advantage of the existing Conical Scanning Microwave Imaging Radiometer (CoSMIR). HyMAS detects 52 channels in two bands that sense water vapor and temperature profiles from the ER-2 high altitude research aircraft. The strategy of using an 18-29 GHz intermediate frequency (IF) enables the scanhead electronics to be extremely modular and compact. Each of 6 absorption bands is mixed down to the same IF, then 8 water vapor channels and 9 temperature profiles are separated out using low profile filters. This filter technology shows promise to miniaturize and improve the performance of future airborne and space atmospheric sounders.

The challenge in the front end electronics is a low noise signal chain. Using a subharmonic mixer, mixer conversion loss of less than 7 dB has been achieved in proven components. The HyMAS receivers use single sideband mixers that downconvert to an IF of 18-29 GHz. The HyMAS IF is beyond the typical operating range of the standard subharmonic mixer. The first and second IF amplifier stages are integrated into the mixer housing, resulting in a highly compact and robust design. To improve the noise figure, we designed in to the scan head layout enough volume for an RF low noise amplifier.

In this paper, we present a system design and laboratory test results that have allowed us to finalize the gain stages in the IF electronics. We have a prediction of system power and mass, presentation of simulated data in a graphical user interface (GUI), and an update on the noise immunity and repeatability of the most recent 9-channel HyMAS filter prototypes at Lincoln Laboratory. A 52-channel unit will be delivered for integration late in 2014.

2. HyMAS DESCRIPTION

CoSMIR heritage

The best physical description of the not yet complete HyMAS is the CoSMIR instrument. HyMAS will operate in the same way, using conical and cross-track scanning. The calibration computer is in the black box behind the in-flight calibration target (in kapton tape). The archive computer receives azimuth encoder pointing data that it gets from the slip ring

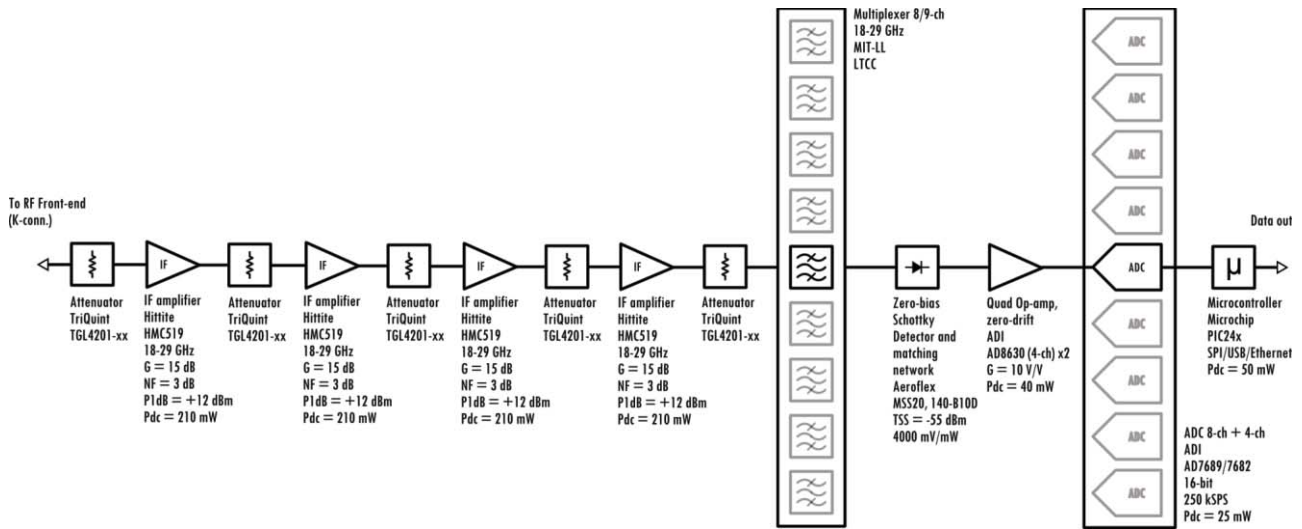
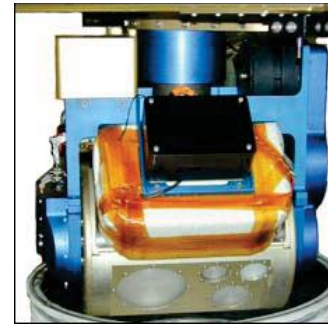
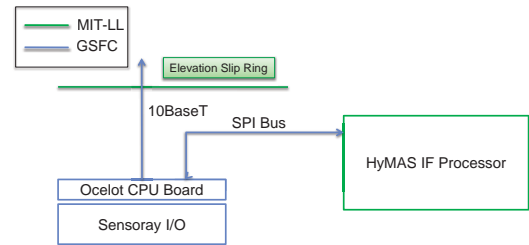
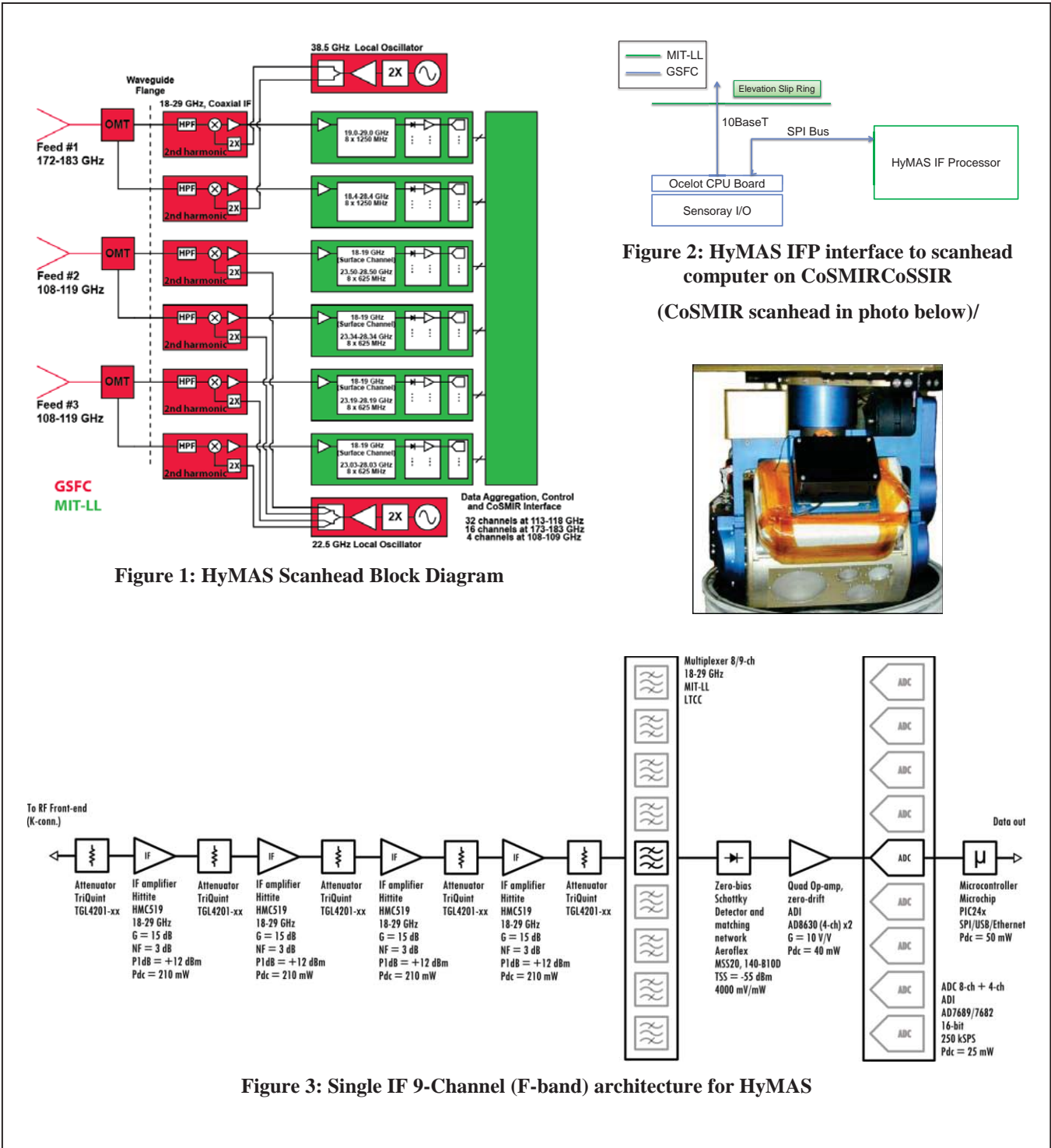

interface, and gets elevation encoder information from the axle of the scan drum.

Six HyMAS analog signal chains will feed two G-Band with 8 filters and four F-band channels with 9 filters adding up to the 52 IF channels that will be captured in the new scanhead. In Figure 1, three matched beam Gaussian optics dual polarization lens antennas (GOAs) create 6 signal chains. The next component on the 118.75 GHz F-Band Channels is a low noise amplifier with a 6.5 dB noise figure across the 108-119 GHz bandwidth. This LNA is unique compared to the CoSMIR/CoSSIR predecessors. Those instruments relied on the mixer conversion loss to set the system noise temperature. We were driven to fit this amplifier in because of the higher conversion loss expected for an 18-29 GHz IF output from a mixer that normally operates from DC-18 GHz. In the next section we will explain the mechanical and signal leveling trades needed to fit in the LNAs on all signal chains.

The next step in the signal chain is the Phase-locked Dielectric Resonator Oscillator (PDRO) and the sub-harmonic mixer. Because of the wide 24.4 percentage bandwidth of the resonant cavity, $29 \text{ GHz} / 118.75 \text{ GHz} = 24.4\%$, we designed in two stages of 18-29 GHz amplification where the match is optimized inside the mixer housing. Coaxial in-line attenuators will be used to match the power level into the Intermediate Frequency Processor amplifier chain. The IFP provides additional amplification to each of the six IF passbands. So far, the low volume IFP prototypes have met all of the filtering and isolation requirements in models that account for many manufacturing and materials dielectric tolerances. The final run will build multi-layer filters that split up the signal into 8 hydrology channels and 9 temperature profile channels per signal chain. The IFP will also house detectors, video amplifiers, the 16-bit analog to digital converters (ADC), and a microcontroller that transfers all 52 channels to the scan head computer over a serial peripheral interface (SPI). The scan head computer stack is a high altitude PC104 with an 8-Channel smart sensor interface board for monitoring physical temperatures measured in the scan head.

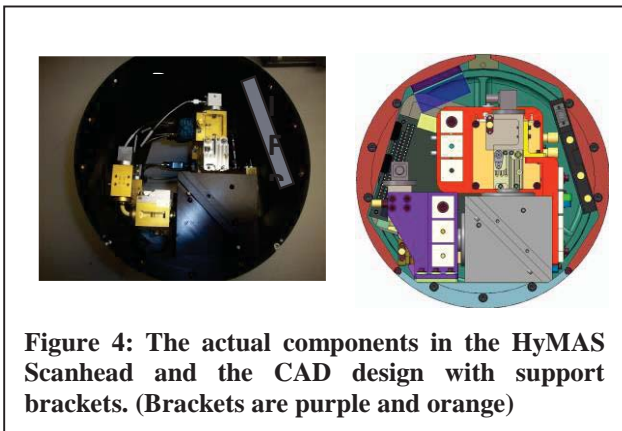

Figure 4: The actual components in the HyMAS Scanhead and the CAD design with support brackets. (Brackets are purple and orange)

HyMAS Scanhead computer aided model

Fitting in the three dual polarization antenna blocks was a challenge resolved by detailed computer aided design (CAD) modeling to design the HyMAS faceplate.

F-Band LNAs

The next critical dimension that was investigated with the computer model was the feasibility of introducing the low noise amplifier in the chain of components attached to the antennas in their respective faceplate positions. The LNAs that we considered were the LNA-08-03210 made by Millitech.

An interference was eliminated when a small 90 degree waveguide bend was introduced after the LNA to take advantage of available volume.

In Figure 4, the end view of the scan head, shows that there is now adequate room for the LNA, waveguide, and mixer/preamp assembly to fit within the drum. Brackets have been designed to provide mechanical support to the cantilevered components.

G-Band LNAs

Due to a cavity in the wall around the feed of the 183 GHz antenna, a 2.5-cm waveguide is necessary to provide clearance for attaching block components such as LNAs.

The 183 GHz LNA is an in-house R&D packaging effort. Figure 5 shows an accommodation for the future home of G-Band LNAs.

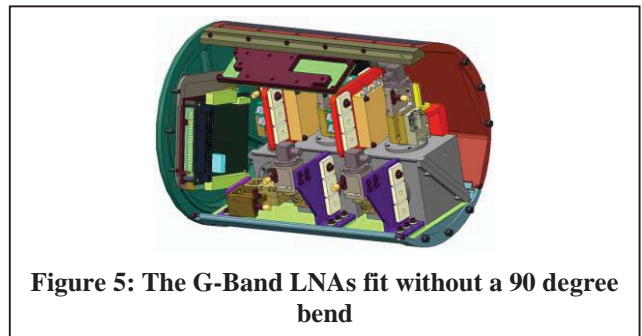

Figure 5: The G-Band LNAs fit without a 90 degree bend

3. ANTENNA PERFORMANCE DATA

Matched Beams

The antenna beamwidths of HyMAS' two waveguide bands were designed to match. Dual polarization is achieved using a wire grid that passes one polarization straight through and reflects the orthogonal polarization. The full-width-half-power beam widths of each of the six beams are between 3.1 and 3.3 degrees. Millitech was the chosen vendor for fabricating the GOAs. The beam efficiency was measured by

rotating the antennas around the boresight axis and integrating the sidelobes.

G-Band tests were performed at Goddard with the test setup compared with measurements taken through the GOA-05, and the single polarization antenna, and Y-factor tests done

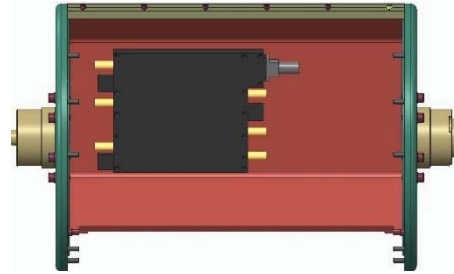
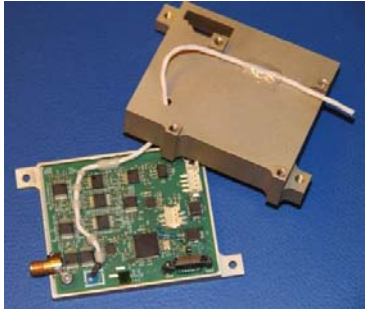

Figure 6: The 9-channel Intermediate Frequency Processor (IFP) Surrogate has been delivered to Goddard for early interface testing with the scan head computer and front end components through a single coax input. The 52 channel IFP footprint with 6 coaxial inputs is designed into the HyMAS scanhead.

Tests at Goddard compared the same input power and range using a single polarization antenna. The antennas were found to exhibit approximately 2 dB loss by comparing the noise figure with that measured using standard gain horns.

Another consideration is the match across the 172-183 GHz bandwidth. The requirement was 1.5:1 over the bandwidth, a worst case return loss (RL) of -13.5 dB was measured at ~180 GHz. For that RL, the mismatch loss is 0.2 dB, the VSWR measures 1.56:1 but the match met the requirement over the majority of the band. For the 107-118 GHz GOAs, the antennas met the matching requirements over the entire band.

4. RECEIVER PERFORMANCE

The subharmonic mixers (SHM) were developed by Virginia Diodes, Incorporated (VDI). VDI was also asked to develop the oscillator chain and the internal matching to the 1st two stages of IF amplification. The VDI standard products are designed to mix down to baseband frequencies DC up to 18 GHz.

The noise performance of the mixers' degrades at intermediate frequencies above 18 GHz. VDI built four F-band and two G-band mixers to produce an 11 GHz bandwidth from 18-29 GHz.

At a single IF frequency, all four mixers were measured to get a basis of comparison for the IF measurement of the system conversion loss. Two external low noise amplifiers were used to make the full band measurement and a narrow band filter recorded the system noise temperature.

Insertion losses, Oscillator power, filters, and amplifiers

VDI also measured the conversion loss of the G-Band mixers and there are curves of data taken across the band at two levels of amplification.

at VDI also using a small single pol antenna. Changes from the setups are that the GOA splits the incoming energy into two polarizations, the GOA connects to the mixer through a 2.5-cm waveguide, and the measurement at Goddard used a broadband detector.

The broadband detector measures out-of-band noise that wasn't measured in the VDI test set-up. High pass filters were implemented on the mixer waveguide input.

Another challenge to the G-band receiver development was a 28.5 GHz spur in the 38.5GHz (183GHz Rx) Phase locked DRO- Multiplier and Amplifier Chain that was mixed and eventually showed up in the IF signal. The frequency spur was attenuated by a narrow pass band filter that knocked this spur down below the system noise floor.

5. IFP PROTOTYPE PERFORMANCE

The computer modeling of the HyMAS Intermediate Frequency Processor (IFP) package accommodation and the Serial Peripheral Interface (SPI) are the Goddard responsibilities in our HyMAS technology development partnership with Lincoln Laboratory (MIT-LL). The lead on the scientific analysis is clearly MIT-LL but CoSMIR and CoSSIR teams both have experience at remote sensing using the 183 GHz water vapor channel. Most of the emission lines will be covered by these three scanhead configurations of the same instrument.

IFP prototype and modeling progress

The IFP design effort at Lincoln Laboratory started with building several 9-channel IFP prototypes, improving circuit modeling based on measured results, and the design of the final 52-channel IFP for the aircraft flight build.

In the course of prototyping, several filter multiplexing and detector circuits were designed and tested. A manifold multiplexer design had lower insertion loss and pass band ripple in simulations; it proved much more difficult to build due to circuit sensitivity to microwave transitions and fabrication tolerances. The multiplexer design using a corporate power divider (using GaAs Lange coupler power dividers) achieved a better IF passband response at the expense of an additional 10 dB of insertion loss.

that has been delivered to Goddard with the rev2 prototype and an emulator that replicates the data format for testing the Serial Peripheral Interface, handshaking protocol, and digital timing and creates a 52 channels for science, 12 channels for housekeeping serial stream. The hybrid manifold technique in Figure 7 requires pairs of identical filters but can accommodate arbitrary number of channels, any channel characteristics, with the bandwidth determined by the hybrid coupler response.

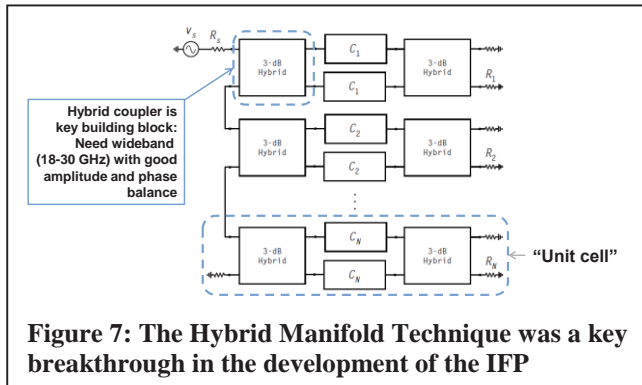

The manifold technique is being pursued for the final version with the manifold integrated in LTCC which eliminates transitions and allows complete modeling in a 3-d EM solver (HFSS). This design will incorporate vertically-stacked filter resonators to achieve the needed compactness for 52 channels. Figure 3 describes a 9-channel engineering model

6. GRAPHICAL USER INTERFACE UPDATE

Displaying all 52-channels and housekeeping data is not possible using the existing PC 104 CoSMIR/CoSSIR scanhead computer operating system. Therefore, a new approach was developed for HyMAS.

Figure 8 illustrates how summary information from all six receiver chains are displayed at once. The Graphical User Interface provides tabs to view the set of signals from any one of the six receiver chains as well as detailed housekeeping data. In this example the mnemonic identifiers chosen for the vertical polarization of F-band antenna 1. On the same time axis, the temperature is plotted against the left axis. Some amount of retrieval of locally archived data and statistical calculation allows the user to see trends in the data over the course of the test.

Efficient display capability will be important in the nuanced

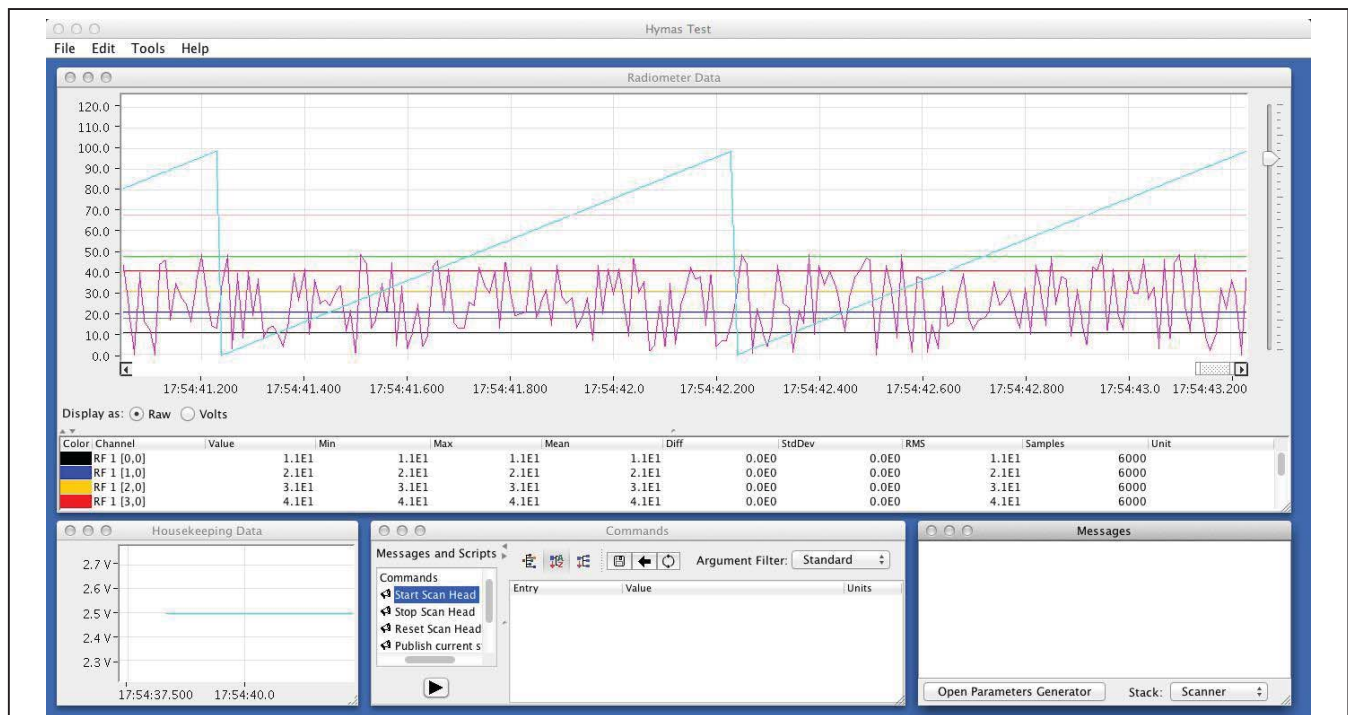

Figure 8: GUI Plot and data display functions for testing the HyMAS surrogate IFP using simulated data

data retrieval and analysis of the hyperspectral data coming from HyMAS. Calibration of the receivers using the in-flight calibration target and the possibly temperature sensitive LNAs in the front end will require close examination of in-flight data.

Table 1 is a comparison of system mass, power, and data requirements with a derivation of the power budget requirement for HyMAS. HyMAS uses less power than its predecessors, weighs less, but processes 52 channels

Table 1: Comparison of CoSMIR/CoSSIR and HyMAS Power

	Component Power	Qty	Total Power(W)
G-Band			
IF amp within the mixer block:	3V, ~150 mA	X 2	1.0
LO source (PDRO @ 38.5 GHz):	8W		8.0
F-Band			
F-Band Pre-amp (prior to the mixer):	15 V; ~ 40 mA	X 4	2.4
IF amp within the mixer block:	3V, ~150 mA	X 4	2.0
LO source (PDRO @ 45.0 GHz):	8W		8.0
Intermediate Frequency Processor			
IF amps in IFP HMC519	220 mW	X12	2.6
AD 8630 Opamp	3 mW	X208	0.7
AD 8679 /7682 A/D Converter	15 mW	X7	0.1
PIC24 Microcontroller	50 mW		0.1
Scanhead computer stack			
PC 104 EBC-Z530-G Clock: 1.6GHz	10.2 W		10.2
COSSIR A/D board: SENSORAY 518	4.8 W		4.8
Thermal control			
The (mini) chip heater: the subminiature controlled heater "DN510"	17W	x24	403.2
TOTAL Power			446

HyMAS can be compared to CoSMIR with 9 channels and CoSSIR with 12 channels. No strip heaters are being used on HyMAS. We are designing it to use chip heaters exclusively. Comparing CoSMIR scanhead power at 450 Watts with 9 channels from 50-183 GHz, and CoSSIR using 460 Watts with 12 channels from 183-874 GHz.

A HyMAS scanhead power requirement of 446 Watts is estimated in Table 4 for 52 channels, broken down as 36 channels at 118 GHz, and 16 channels at 183 GHz, and heaters to maintain the operating temperature while at altitude.

7. SUMMARY

The HyMAS scanhead technology will enable a new era of missions with an all-weather capability to improve atmospheric sounding in and around storm systems. The reduced volume, mass, and power requirements are envisioned to enable a set of missions to provide rapid, high resolution sounding with global coverage. The hyperspectral sensing technology is applicable other measurement systems that use measure Earth science phenomena directly at that span the 18-29 GHz spectrum such as ice and snow sensing.

This work was sponsored by the National Aeronautics and Space Administration under Air Force contract FA8721-05-C-0002 and the NASA's 2011 Earth Science Technology Office (ESTO) Advanced Component Technology (ACT)

REFERENCES

- [1] Blackwell, William, Bickmeier, L. J., Leslie, R. V., Pieper, M., L., Samra, J. E., Surussavadee, C., Upham, C. A., "Hyperspectral Microwave Atmospheric Sounding," IEEE Trans. Geoscience and Remote Sensing, Dec. 2010.
- [2] Do, James, "VDI User Guide: 118GHz Radiometer (VDI-Rx-151)", 5 April 2013.
- [3] Culley, John, "Hyperspectral Microwave Atmospheric Sounder", Virginia State University Summer Internship, 10 July 2013.
- [4] Engler, Charles, "Assembly Procedure Scan Drum to Instrument Structure CoSMIR and CoSSIR Instruments", CoSMIR-121901_Rev3, 22 April, 2004.
- [5] Evans, K. Franklin, "Report on CoSSIR 2009 Test Flights", Report of Department of Atmospheric and Oceanic Sciences, University of Colorado, Boulder.
- [6] Hilliard, Lawrence , Racette, P. Blackwell, W.J. , Galbraith, C. , Thompson, E. , "Hyperspectral Microwave Atmospheric Sounder (HyMAS) Architecture and Design Accommodations", IEEE Aerospace Conference, 3-9 March, 2013; Big Sky; Montana.
- [7] Langlois, Philip, "Antenna Test Data Sheet: Gaussian Optics Lens Antenna GOA-05-R001.5DN", 26 February 2013.
- [8] Lee, James, "HyMAS Depictions", Elizabeth City State University Summer Internship, 25 July 2013.
- [9] Timmons, Elizabeth, "HyMAS_Review_Slides.pptx" , 4 June 2013.
- [10] Zhang, Zhaonan , "Re-measurements of Noise Temperature for the HyMAS Receivers", 9 September 2013.

BIOGRAPHY



Lawrence M. Hilliard received a B.S. in Electrical Engineering from Michigan Technological University in 1983. He has been with NASA GSFC for more than 30 years. He is currently development lead for VLBI2010 in the Space Geodesy Project (SGP) at Goddard. Prior to SGP, he led an AESMIR aircraft instrument team winning a Robert Goddard Exceptional Achievement Award. He has also managed efforts for COBE-DMR, SWAS, and Swift-BAT instrument and payload development and has been involved in the formulation and development of numerous aircraft and Earth-orbiting spacecraft and payloads. His career started with parts engineering on the GOES program for NASA Goddard.



William J. Blackwell received the B.E.E. degree in electrical engineering from the Georgia Institute of Technology, Atlanta, GA, in 1994 and the S.M. and Sc.D. degrees in electrical engineering and computer science from the Massachusetts Institute of Technology (MIT), Cambridge, MA, in 1995 and 2002. Since 2002, he has worked at MIT Lincoln Laboratory, where he is currently an Assistant Leader of the Sensor Technology and System Applications Group. His primary research interests are in the area of atmospheric remote sensing, including the development and calibration of airborne and spaceborne microwave and hyperspectral infrared sensors, the retrieval of geophysical products from remote radiance measurements, and the application of electromagnetic, signal processing and estimation theory. Dr. Blackwell held a National Science Foundation Graduate Research Fellowship from 1994 to 1997 and is a member of Tau Beta Pi, Eta Kappa Nu, Phi Kappa Phi, Sigma Xi, the American Meteorological Society, the American Geophysical Union, and Commission F of the International Union of Radio Science. He is currently an Associate Editor of the IEEE Transactions on Geoscience and Remote Sensing and the IEEE GRSS Newsletter. He is Chair of the IEEE GRSS Frequency Allocations for Remote Sensing (FARS) technical committee, the IEEE GRSS Remote Sensing Instruments and Technologies for Small Satellites working group, and the Boston Section of the IEEE GRSS and serves on the NASA AIRS and Suomi NPP science teams and the NPOESS Sounding Operational Algorithm Team. He is the Principal Investigator on the MicroMAS (Micro-sized Microwave Atmospheric Satellite) program, comprising a high-performance passive microwave spectrometer hosted on a 3U cubesat planned for launch in 2013. He was previously the Integrated Program Office Sensor Scientist for the Advanced Technology Microwave Sounder on the Suomi National Polar Partnership that launched in 2011 and the Atmospheric Algorithm Development Team Leader for the NPOESS Microwave Imager/Sounder. Dr. Blackwell received the 2009 NOAA David Johnson Award for his work in neural network retrievals and microwave calibration and is co-author of Neural Networks in Atmospheric Remote Sensing, published by Artech House in July, 2009. He received a poster award at the 12th Specialist Meeting on Microwave Radiometry and Remote Sensing of the Environment in March 2012 for "Design and Analysis of a Hyperspectral Microwave Receiver Subsystem" and was selected as a 2012 recipient of the IEEE Region 1 Managerial Excellence in an Engineering Organization Award for outstanding leadership of the multi-disciplinary technical team developing innovative future microwave remote sensing systems."



Paul E. Racette has been the principal engineer responsible for the overall instrument concept, development and deployment of highly-innovative remote sensing instruments. Each of these instruments has produced unique, scientifically rich data. Paul has participated in more than fifteen major field experiments around the world pioneering techniques to observe the Earth. As a member of the senior technical staff at Goddard, he has initiated technology developments, research projects, and international collaborations that have advanced the state of the art in microwave remote sensing and instrument calibration. For these efforts and accomplishments Paul received the NASA Medal for Exceptional Service and was the first recipient of Goddard's Engineering Achievement Award.

Paul is highly committed to serving the public through professional activities. Paul has served the IEEE in many capacities including secretary of the University of Kansas' IEEE student chapter, the Geoscience and Remote Sensing Society's New Technology Directions Committee Representative, Chair of the Instrumentation and Future Technologies Committee, and Professional Activities Committee for Engineers Representative. He now serves as Editor-In-Chief for Earthzine.



Christopher J. Galbraith is a member of the Technical Staff at MIT Lincoln Laboratory in the RF and Quantum Systems group where he develops microwave circuits for communications, radar, and radiometric systems, small form-factor packaging and antennas, and superconducting electronics. He received the B.S.E.E., M.S.E.E.

and Ph.D degrees from the University of Michigan, Ann Arbor. During the summers of 2001 and 2002, he was an intern with TRW Space and Electronics, Redondo Beach, CA, where he worked on satellite communications systems and microwave circuit design. He is active in the IEEE Microwave Theory and Techniques society (MTT-S) where he currently serves as the chair of the Boston chapter.



Erik Thompson Assistant Staff at MIT Lincoln Laboratory. He received a B.E. in Electrical Engineering from Stevens Institute of Technology. As a Stevens student Thompson was selected as the Cooperative Education and Internship Student of the Year award by the New Jersey

Cooperative Education and Internship Association (NJCEIA).

As an undergraduate at Stevens, Thompson took part in five Co-op internships. The first two assignments were with Datascope Patient Monitors, where he worked with the electrical engineering staff to test hospital products and implement fixes. Next, he worked as a computer engineer at the Armament, Research, Development and Engineering Center (ARDEC) at Picatinny Arsenal. Finally, Thompson spent two semesters at Safe Flight Instrument Corporation. There, he served as project lead for the development of cockpit sensors that prevent airplanes from stalling. He was primarily responsible for overseeing the design and testing of software and electronics systems.