

Figure 4.— SEM images and EDX spectra for four particles harvested from collector L2094. These EDX spectra are consistent with an extraterrestrial origin.

## ***GeoLab: A Geological Workstation for Future Missions***

*Cynthia Evans, Michael Calaway, Mary Sue Bell*

*Zheng Li, Shuo Tong, Ye Zhong, Ravi Dahiwal (University of Bridgeport)*

The GeoLab glovebox was, until November 2012, fully integrated into NASA’s Deep Space Habitat (DSH) Analog Testbed (figure 1). The conceptual design for GeoLab came from several sources, including current research instruments (Microgravity Science Glovebox) used on the International Space Station, existing Astromaterials Curation Laboratory hardware and clean room procedures, and mission scenarios developed for earlier programs.

GeoLab allowed NASA scientists to test science operations related to contained sample examination during simulated exploration missions. The team demonstrated science operations that enhance the

early scientific returns from future missions and ensure that the best samples are selected for Earth return. The facility was also designed to foster the development of instrument technology.



*Figure 1.– GeoLab glovebox (left) inside NASA's DSH (right).*

Since 2009, when GeoLab design and construction began, the GeoLab team [a group of scientists from the Astromaterials Acquisition and Curation Office within the Astromaterials Research and Exploration Science (ARES) Directorate at JSC] has progressively developed and reconfigured the GeoLab hardware and software interfaces and developed test objectives, which were to 1) determine requirements and strategies for sample handling and prioritization for geological operations on other planetary surfaces, 2) assess the scientific contribution of selective in-situ sample characterization for mission planning, operations, and sample prioritization, 3) evaluate analytical instruments and tools for providing efficient and meaningful data in advance of sample return and 4) identify science operations that leverage human presence with robotic tools.

In the first year of tests (2010), GeoLab examined basic glovebox operations performed by one and two crewmembers and science operations performed by a remote science team. The 2010 tests also examined the efficacy of basic sample characterization [descriptions, microscopic imagery, X-ray fluorescence (XRF) analyses] and feedback to the science team. In year 2 (2011), the GeoLab team tested enhanced software and interfaces for the crew and science team (including Web-based and mobile device displays) and demonstrated laboratory configurability with a new diagnostic instrument (the Multispectral Microscopic Imager from the JPL and Arizona State University). In year 3 (2012), the GeoLab team installed and tested a robotic sample manipulator and evaluated robotic-human interfaces for science operations.

**GeoLab Robotic Sample Manipulator.** Sample-return missions have strict protocols to reduce potential contamination of samples, and sample handling in microgravity presents special challenges. To begin to address these challenges in the GeoLab, scientists at JSC joined engineering students from the University of Bridgeport in Bridgeport, CT. The students were awarded one of the 2012 National Space Grant Foundation Exploration Habitat (XHab) Academic Challenges (see

[http://www.nasa.gov/exploration/technology/deep\\_space\\_habitat/xhab/xhab-2012-progress.html](http://www.nasa.gov/exploration/technology/deep_space_habitat/xhab/xhab-2012-progress.html)) to develop an engineering design for tools to handle geological samples for analysis in a microgravity glovebox environment. The Bridgeport XHab team designed and built a robotic arm system with a three-finger gripper that could manipulate geologic samples within the existing GeoLab glovebox (figure 2). An innovation developed by the Bridgeport team was the large curvature of each finger, a design that reduced contact with the irregular surfaces of a rock sample, thus minimizing contamination risk while still allowing a significant capture force to be applied to the uneven surfaces of a rock (figure 3).

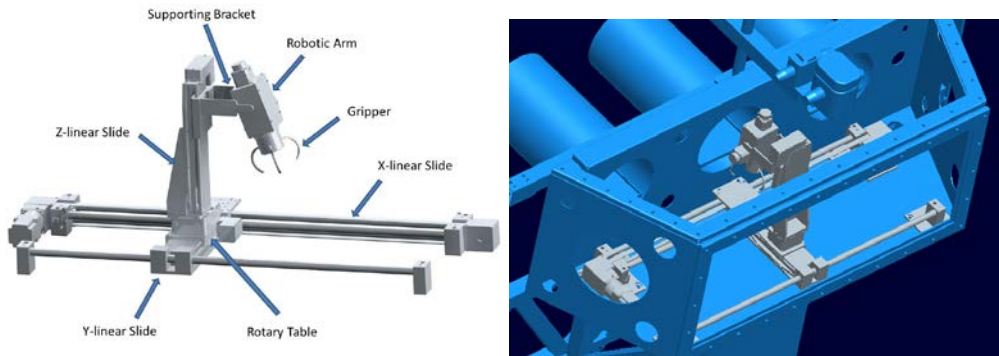

*Figure 2.— GeoLab Robotic Sample Manipulator computer-aided design (CAD) design and CAD rendering of the robotic arm inside a glovebox, created by the University of Bridgeport XHab 2012 team.*



*Figure 3.— Views of the robotic sample manipulator three-fingered end effector holding and positioning rock samples.*

The robotic manipulator was required to be able to capture and release samples, translate the full volume of the glovebox, and precisely manipulate samples for imaging, microscopic examination, and positioning for XRF analyses. The full range of motion (translation in the X, Y, and Z directions, up and down pivot motion, and rotating end effector) was accomplished with a linear slide for the length of the glovebox (X-direction) and precision linear stages or motion along the Y and Z axes. The Z-axis linear stage was mounted on a motorized rotary stage.

All four (X, Y, Z, and rotation) stages were enabled by a motion controller. The robotic arm pitch used a series of enclosed gears attached to a motor. The three-fingered grasper enabled 360° rotation with two additional motors; all three motors were controlled by one controller. Both controllers were Ethernet enabled and connected to the DSH avionics network switches. The software interface for the controllers was a touch-screen display, mounted above the glovebox, designed by the DSH software team.

The tests of the robotic arm provided insight into technologies that will be required for higher readiness levels. The ultimate goal is to build a robotic system that can autonomously conduct the preliminary examination of returned samples and downlink this data to Earth-based mission scientists. The team's current goal for sample science in the context of planetary exploration is to have autonomous robotic systems, assisted by human crewmembers when required, that can 1) collect and stow samples in an archival manner, 2) conduct preliminary examination of samples, 3) downlink the data to mission scientists for sample return prioritization, and 4) maintain rigorous curation protocols that preserve the scientific integrity of the samples.

**Three Years of GeoLab Tests.** Over the 3 years that GeoLab was integrated into the DSH, GeoLab participated in 19 days of simulated mission testing and monitored operations with 18 different test subjects. The GeoLab team also conducted standalone tests with nearly 20 other operators. While complete compilation and assessment of test results are still underway, the GeoLab team can confidently report the following:

- 1) *The GeoLab design supports autonomous crew operations of the basic glovebox functions.* The trained crew enhances science returns by providing spontaneous observations; this is especially important when time delays preclude real-time science team involvement.
- 2) *Good sample imagery is key for preliminary characterization.* Imagery collected at a range of scales forms the basis for additional characterization. The earliest tests indicated that basic microscopy provided invaluable data for rapid assessment of samples.
- 3) *Robotic assists for sample handling are critical in microgravity.* Robotics aid crew and enable precision sample handling for data collection. The 2012 tests validated the quantity and quality of microscopy that could be achieved with a robotic sample holder. The sample holder made possible one-person operations (crew efficiency), provided flexibility in sample positioning (see figure 3), and enabled systematic sample positioning, allowing for mapping of the sample for future analyses. Finally, proper robotic sample handling can result in less sample handling and therefore present less risk of damaging or compromising a sample.
- 4) *A combination of imaging tools and robotic tools provides significant flexibility for designing facilities and operations related to sample characterization and sample handling.* Progressive tests using robotic interfaces will help develop requirements, instruments, and procedures for different exploration scenarios.

- 5) *Preliminary sample characterization provides data that supports smart decisions during mission operations.* Data supports sample prioritization, enables a better understanding of the regional geology being explored, highlights details on samples, and is useful for future exploration plans. The types of data that were collected in the GeoLab during the analog tests allow for wide dissemination and broad participation by scientists and students on Earth.

## *Dividing the Concentrator Target From the Genesis Mission*

*H. V. Lauer, Jr., P. J. Burkett, S. J. Clemett, C. P. Gonzales,  
K. Nakamura-Messenger, M. C. Rodriguez, T. H. See, B. Sutter*

The Genesis spacecraft, launched in 2001, traveled to a Lagrangian point between the Earth and Sun to collect particles from the solar wind and return them to Earth. However, during the return of the spacecraft in 2004, the parachute failed to open during descent, and the Genesis spacecraft crashed into the Utah desert. Many of the solar wind collectors were broken into smaller pieces, and the field team rapidly collected the capsule and collector pieces for later assessment. On each of the next few days, the team discovered that various collectors had survived intact, including three of four concentrator targets. Within a month, the team had imaged more than 10,000 fragments and packed them for transport to the Astromaterials Acquisition and Curation Office within the ARES Directorate at JSC. Currently, the Genesis samples are curated along with the other extraterrestrial sample collections within ARES.

Although they were broken and dirty, the Genesis solar wind collectors still offered the science community the opportunity to better understand our Sun and the solar system as a whole. One of the more highly prized concentrator collectors survived the crash almost completely intact (figure 1). The Genesis Concentrator was designed to concentrate the solar wind by a factor of at least 20 so that solar oxygen and nitrogen isotopes could be measured.

One of these materials was the Diamond-on-Silicon (DoS) concentrator target. Unfortunately, the DoS concentrator broke on impact (figure 1). Nevertheless, the scientific value of the DoS concentrator target was high. The Genesis Allocation Committee received a request for  $\sim 1 \text{ cm}^2$  of the DoS specimen taken near the focal point of the concentrator for the analysis of solar wind nitrogen isotopes. The largest fragment, Genesis sample 60000, was designated for this allocation and needed to be precisely cut. The requirement was to subdivide the designated sample in a manner that prevented contamination of the sample and minimized the risk of losing or breaking the precious requested sample fragment.

The Genesis curator determined that the use of laser scribing techniques to “cut” a precise line and subsequently cleave the sample (in a controlled break of the sample along that line) was the best method for accomplishing the sample subdivision. However, there were risks, including excess heating of the sample, that could cause some of the implanted solar wind to be lost via thermal