

# Development of the RANCOR Rotary-Percussive Coring System for Mars Sample Return

Gale Paulsen<sup>\*</sup>, Stephen Indyk<sup>\*</sup> and Kris Zacny<sup>\*</sup>

## Abstract

A RANCOR drill was designed to fit a Mars Exploration Rover (MER) class vehicle. The low mass of 3 kg was achieved by using the same actuator for three functions: rotation, percussions, and core break-off. Initial testing of the drill exposed an unexpected behavior of an off-the-shelf sprag clutch used to couple and decouple rotary-percussive function from the core break off function. Failure of the sprag was due to the vibration induced during percussive drilling. The sprag clutch would back drive in conditions where it was expected to hold position. Although this did not affect the performance of the drill, it nevertheless reduced the quality of the cores produced. Ultimately, the sprag clutch was replaced with a custom ratchet system that allowed for some angular displacement without advancing in either direction. Replacing the sprag with the ratchet improved the collected core quality. Also, premature failure of a 300-series stainless steel percussive spring was observed. The 300-series percussive spring was ultimately replaced with a music wire spring based on performances of previously designed rotary-percussive drill systems.

## Introduction

In 2010, NASA considered three mobility architectures for the next Mars mission. These included the MER-size rover, MER+ rover which was approximately 30% heavier than MER, and the MSL-size rover [1]. Since the goal of the future mission was to capture rock cores and cache them for potential sample return, Honeybee Robotics was tasked with a development of a core drilling system. The drill had to be mass optimized to fit either the MER or the MER+ platforms. It should be noted that the MER robotic arm, called the Instrument Deployment Device or IDD, was designed to carry approximately 2 kg of payload at its end. It was assumed that a slightly larger arm on MER or MER+ could potentially carry 3 or even 4 kg of payload. With that in mind, the driving goal of the project was to design a drill that would weigh approximately 3 kg or less. It should be noted that at the same time parallel drill development efforts focused on other aspects of the rotary-percussive coring systems such as reducing the sampling complexity [2].

To help reduce the mass of the RANCOR drill, a number of mechanisms were designed to be driven by a single actuator. The result was a two actuator drill that drives 4 degrees of freedom.

One of these actuators drives three degrees of freedom. These are the auger and bit rotation, percussive mechanism, and the mechanism used to break off the core. The second actuator is used to lock and unlock the drill bit from the chuck so that bits can be removed and inserted into the drill head and also to enable bits to be removed from the drill head at any time (i.e. if the bit is stuck in a rock). When complete,



**Figure 1. Weigh-in picture of the final mechanical assembly of the RANCOR drill**

<sup>\*</sup> Honeybee Robotics Spacecraft Mechanisms Corporation, Pasadena, CA

these design choices helped in reaching a final drill mass of 2.9 kg, including cable harnessing (2.8 kg without the cable harness as shown in Figure 1).

Another major requirement was for the drill to interface with an existing Integrated Mars Sample Acquisition and Handling (IMSAH) architecture developed by the Jet Propulsion Laboratory (JPL) [3, 4]. This architecture relies on an embedded sample tube that collects the core during drilling. Once a core is drilled and captured, the bit must be docked to IMSAH and subsequently detached from the drill head. At this stage, a mechanism within IMSAH is inserted into the back end of the drill bit to remove the sample tube with the core. This full sample tube is then cached into a separate caching mechanism and a new clean sample tube is collected and reinserted into the back end of the drill bit. At this point the drill head can mate with the drill bit again to drill and capture a new core.

### RANCOR Drill Overview

The core mechanical components of the RANCOR drill are shown in Figure 2. This includes everything except for the drive motor, spring Z stage, and proximity sensor for homing the auger axis. In this cross section it is evident how the auger and breakoff shaft are driven together with the cam/follower percussive mechanism while rotating the Cam Shaft Upper in one direction. When rotating this shaft in the opposite direction, the overrunning clutch (eventually replaced with a ratchet) decouples rotation of the cam and auger, thus rotating only the breakoff shaft. This is the mechanism that enables relative rotation between the breakoff shaft and auger to shear and capture cores.

#### RANCOR Drill Bit

At the working end of any drill is the drill bit. The RANCOR coring drill bit is comprised of 3 main components: the auger, breakoff tube, and JPL sample tube (Figure 3 and Figure 4). The auger was designed around the JPL Sampling tube and requirements for collecting a core sample of 6-cm length and 1-cm diameter. To break and capture the core, the Honeybee Robotics patented eccentric tube technology was used [5]. The auger shank was designed to fit with the three sets of guide wheel rollers found on the chuck. To make the chuck as compact as possible, the shank of the drill bit became an almost equilateral hexagon. Weight reduction features were created in the auger since this component alone comprised about 8% of the overall drill mass. Hence, there are three pockets on the alternate hexagon surfaces. It should be noted that the bit was designed to survive the load from the theoretical rover slip condition under Mars gravity. A 180-kg rover on a 20-degree slope would apply approximately 173-N side force to the bit.

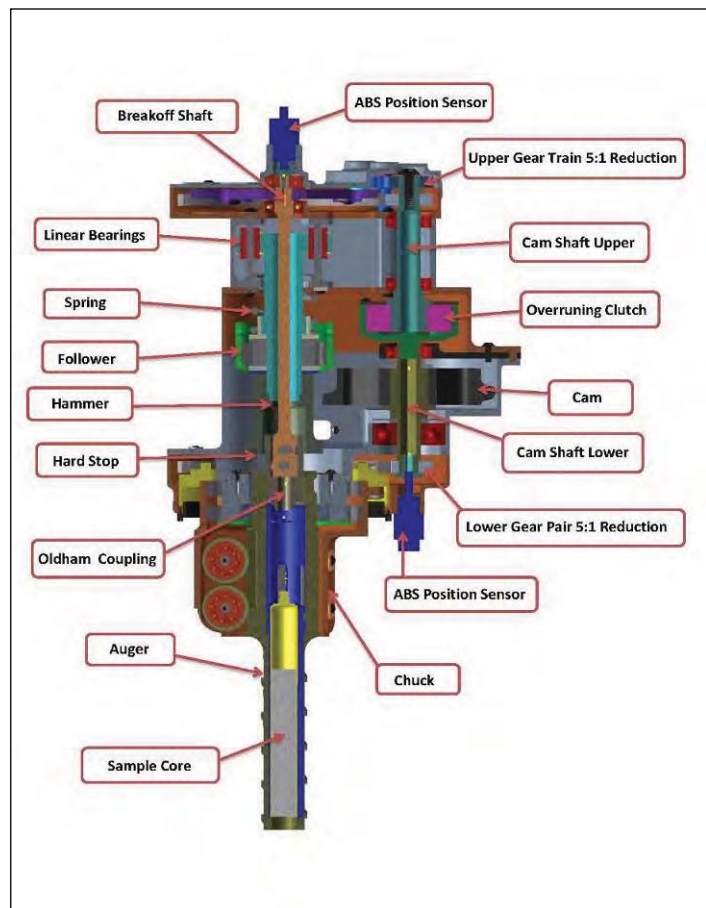
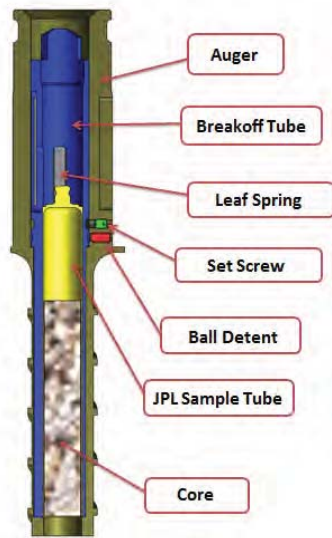
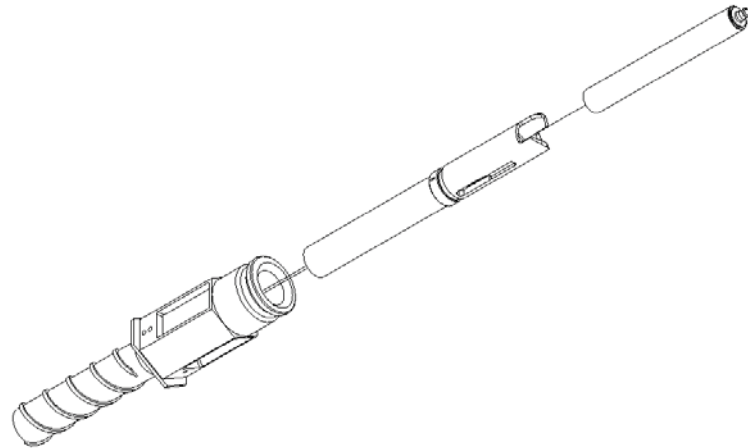

Figure 2. Details of the RANCOR drill components



**Figure 3. CAD image of the drill bit with its components labeled**



**Figure 4. Picture of the drill bit in an exploded drawing view, Auger, Breakoff Tube and JPL Sample Tube Visible**

Constraining the auger vertically in the drill are the small flanges that protrude from the hexagonal surface. The side of this feature fits in flats in the front end of the chuck. The groove in the shank is for mating with a cam in the bit lock mechanism to constrain the drill bit from falling out. Additionally, the rounded surface at the shank end mates with a seal to prevent dust or cuttings from entering the drill when the auger is in place. Caution should be taken in regards to cuttings and other debris since the complete drill bit assembly (complete with the JPL sample tube) should be in place to form a dust protective seal. However it is important to note that this assembly is not a perfect seal.

Material selection for the auger was decided based primarily on previously designed and tested Honeybee bit designs. The RANCOR bit uses a 455 stainless steel that has been heat treated to condition H900. This specialty steel was selected for its high performance characteristics of strength, toughness, and hardness. After manufacturing and heat treatment of the auger was complete, four rotary grade carbide inserts were brazed into place at the nose of the auger to serve as the cutting surfaces. Harder grade carbide was selected because this grade of carbide has been shown to survive percussion well when operating at relatively low percussive energy levels. At approximately 0.6 J/blow, the RANCOR drill falls into the category of low percussive energy. The advantage to using harder grade carbide is increased bit life, so long as the carbide doesn't fracture.

The breakoff tube (Figure 5) was also designed around the existing JPL Sampling tube. This mechanism interfaces with an Oldham coupling which is part of the core breakoff system. Design challenges for the breakoff tube included manufacturing for tight tolerances and clearances between the auger and the Oldham coupling interfaces. Different JPL sample tubes were expected to be inserted into the breakoff tube. Interfacing with multiple JPL sample tubes was expected to be difficult from a tolerance standpoint as they are thin walled structures and are vulnerable to deformation. To finalize the ID of the breakoff tube, multiple JPL sample tubes were measured and the statistical deviation of the maximum sample tube diameter was determined. Then the breakoff tubes were appropriately reamed to 0.4440 inch (11.28 mm) to accommodate all of the existing JPL sample tubes. The material used for the breakoff tube was 416 Stainless Steel which allowed for design flexibility in that a harder metal could be obtained through heat treatment if it was deemed necessary.



**Figure 5. RANCOR breakoff tube**

It is expected that the life of the breakoff tube will be able to outlive the life of the auger. In future designs, the following items should be considered to improve the design of the mechanism:

- Minimize the sliding friction between the inside surface of the auger and the outside surface of the breakoff tube. This could be done by using bronze bushings or even a concentric turning of the middle section of the breakoff tube.
- A better system of constraining the breakoff tube should be considered. Primarily, this concerns the replacement of the set screws. From test results, it is evident that the set screws have the potential of backing out if not installed correctly. Because of this, gouging can occur between the auger and breakoff tube, potentially causing them both to become jammed. The primary reason for using set screws here was to enable frequent disassembly of the drill bit assembly to monitor component wear and dust migration.

The final component that comprises the RANCOR coring drill bit is the JPL sample tube (Figure 6). This component is manufactured by JPL and is made of stainless steel. From an operational perspective, once the drill bit is docked with the JPL IMSAH system, the drill head separates from the drill bit and the JPL sample tube is extracted through the back end of the bit using an internal IMSAH mechanism. It is then cached within IMSAH for sample collection and analysis.



**Figure 6. JPL Sample tube**

#### RANCOR Chuck

Bridging the coring drill bit to the rest of the drill body is the chuck (Figure 7). Studied extensively during the concept and breadboarding phase of the project, the architecture of the chuck did not change dramatically from its initial concept. One of the driving requirements on the RANCOR drill was the ability to sustain the loads induced on the drill body and bit should the rover be drilling on a sloped surface and lose traction, or slip. The chuck serves as the primary interface for surviving and handling the load from the theoretical rover slip condition under Mars gravity. Slip conditions of a 180-kg rover on a 20-degree slope were needed to be survivable with the final chuck design. Under this loading condition the RANCOR chuck and drill bit would be expected to survive side loads as high as 173 N, as well as be able to safely eject the bit. Both conditions were met.



**Figure 7. RANCOR drill chuck and drill bit**



**Figure 8. Side view of the guide wheel roller, clearly showing the Nedox coating, and the two curved contact surfaces for maintaining near line contact with the bit shank**

RANCOR's final chuck design is comprised of six guide wheel rollers arranged in 3 pairs, 120 degrees apart from each other to constrain the drill bit. This configuration was chosen as a superior weight reduction design as opposed to a more conventional eight roller set in a 90-degree separated orientation. Utilizing guide wheels in this chuck is a key feature for enabling successful ejection of the drill bit under high loading conditions. The design also helps guide the drill bit insertion and minimizes percussive energy loss by allowing a small amount of axial motion during drilling. As shown in Figure 8, the surface of the guide wheel rollers is curved in two positions to help maintain line contact with the bit shank and still provide a means for transmitting torque to the bit. Maintaining the four surface contacts on each wheel set ensures that the auger is constrained in that plane and only allows axial motion from the drill bit. The drawback from this design is the relative size of the chuck required to house the rollers. However, this design still enables a maximum drill angle relative to the normal vector to the rock to be as large as 26 degrees and still allow for a 6-cm-long core to be captured before the chuck touches the rock. This allows for significant margin in the angular positioning accuracy of a robotic arm relative to the local surface normal of the rock.

The geometry of the chuck housing was optimized to minimize weight. CNC milling was required to fabricate the chuck housing out of a single piece of 6061 aluminum. Material for the guide wheels were selected as 455 stainless steel heat treated to condition H900 and plated with a Nedox SF-2 coating to reduce the rolling friction and increase the surface hardness. Steel pins were pressed through the bearings in the guide wheel rollers. Post-assembly, dimension checks were performed by inserting the drill bit augers into the chuck. Any tolerance corrections were then made by removing small amounts of material from the hexagonal faces of the bit shank. Interfacing the auger with the rest of the drill housing required a durable bearing interface. Sealed Silverthin JSA020 four point contact bearings were chosen for this purpose. Matched in pairs, these bearings are capable of sustaining thrust loads up to 3527 N under dynamic conditions and 7615 N under static conditions. Life expectancy of these bearings under expected loads show that these bearings should out last other bearings and components of the drill system. Overall, the functionality of the chuck and its minimal weight were favorable over other design alternatives designed to the same requirements. This chuck design has proven to be a reliable and robust component of the drill. Mass of the chuck was calculated to be 0.444 kg, approximately 15% of the overall drill weight.

Driving the chuck is the main drive motor for the drill, a Maxon 22-mm size brushless motor. In an effort to minimize weight and simplify operation, coupling the percussion mechanism with the auger rotation

allows for utilizing one actuator instead of two. Three Maxon motor combinations were tested for the drill unit. This was done to allow a high RPM as well as a high torque option to be evaluated during testing. Outputs from these various combinations were 272 RPM at 3.1 N-m continuous, 188 RPM at 4.3 N-m continuous, and 103 RPM at 6.7 N-m continuous. The high speed option worked well at speeds above 20 RPM. However, lower speeds were required for initializing and aligning the auger and breakoff tube when the system starts. The easiest solution to this was to simply exchange the planetary gearhead on the motor. The next size that fit the existing pinion gear on the motor produced the 103-RPM drill rate. This solution was not ideal from a drilling perspective, but met the system requirements and functioned well. Later the 188-RPM solution was implemented (this required a longer lead time) and also fit the requirements, but improved the performance of the drill. Ultimately, this option was selected as the final version.

#### RANCOR Overrunning Clutch (Sprag)

As previously mentioned, the rotation, percussion, and breakoff axes are driven by a single actuator. During a drilling operation, the actuator drives the auger and breakoff shaft simultaneously while the percussion axis rotates at 5 times the rate of the auger / breakoff axes. After drilling, the rock core is sheared at the base to capture it within the bit. To accomplish this, a clutch was implemented to separate the percussion cam and auger from the breakoff axis while driven in the opposite drilling direction. This allows the breakoff axis to rotate while the percussion and auger remain stationary. The drive train path is highlighted in Figure 9 with the blue path representing the breakoff axis and the red path representing the percussion and auger axes.

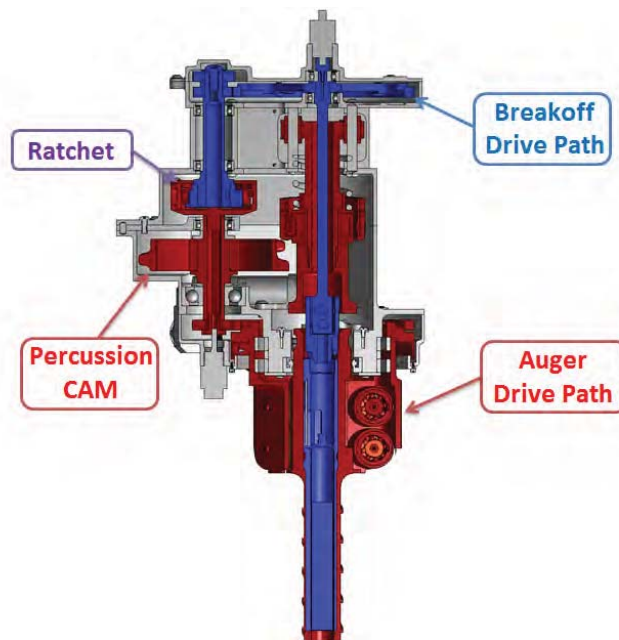
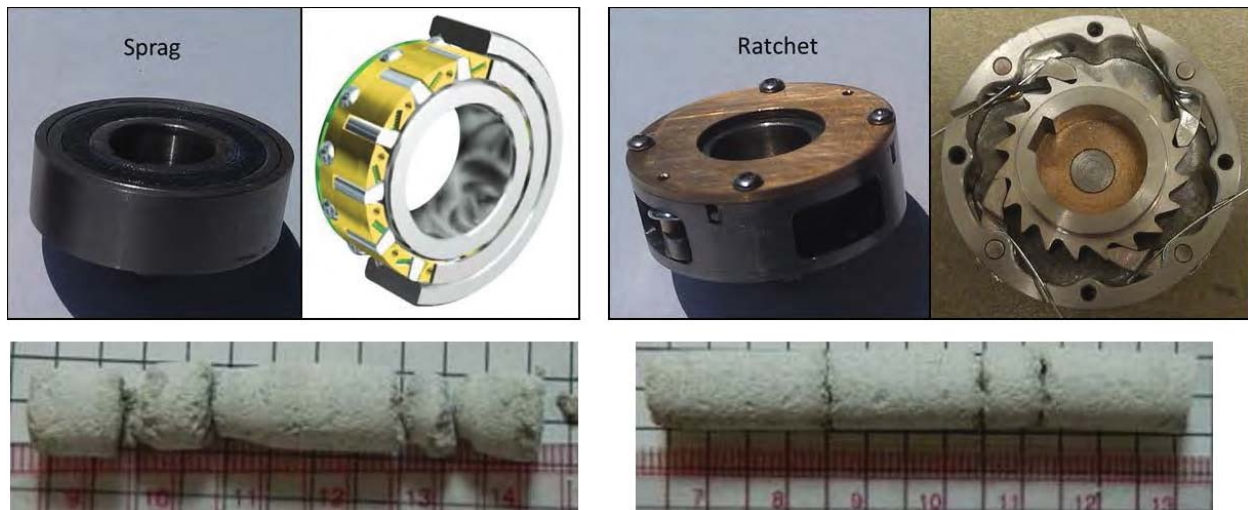

**Figure 9. Ratchet used to couple / decouple the percussion & auger rotation from the breakoff axis**

Initially an over running clutch, which utilizes sprags, was implemented. Though this mechanism performed as it should have, there was an operational behavior that was overlooked. Since the CAM must compress a spring and release the load over a short duration, there is a highly cyclical load on the CAM shaft. When the load is released there seems to be a combination of inertial effects and physical effects with the interface between the follower and the CAM that causes the CAM, and therefore the Auger axis to advance ahead of the breakoff axis. This effect caused poor quality cores to be produced, as shown in the bottom left image of Figure 10. Given the fine resolution of the sprag, these small advancements are captured, which causes relative motion between the auger and breakoff axes during a

drilling operation. At 100-RPM auger rotation, it takes about 500 percussion impacts to create a full 360° relative displacement between the auger and breakoff axes. Tests have shown that lower velocities generate higher displacements per blow and that when drilling into harder materials, this relative motion can be contained. However, this motion is unacceptable from a performance perspective. To solve this problem, a custom ratchet mechanism was designed to replace the sprag clutch.

The ratchet design shown in Figure 10 required more components and was significantly more expensive than the off the shelf sprag clutch. However, it offers two key features that make it an ideal solution to the problem of the auger advancing ahead of the breakoff axis. The first feature is the more coarse resolution. In this case, the cam would have to advance 18° ahead of the input shaft upon release to cause a shift in one tooth of the ratchet. This is far more than the average 4° shift that was observed with the sprag. The second key feature offered by the ratchet is that a more controllable force is required to cause the ratchet to advance. In the ratchet designed for this application, it takes approximately 0.5 N-m to advance the outer housing for the ratchet (well within the capabilities of the drive motor). This excludes frictional forces which are difficult to characterize and vary with temperature, pressure, vibration, and a number of other factors. In the case of the sprag, there were only rolling contact frictional forces to overcome to advance the outer race of the sprag. After implementing the ratchet mechanism into the final RANCOR drill assembly, the auger no longer advanced ahead of the breakoff shaft during drilling, resulting in a significant improvement in core quality, as shown in the bottom right image of Figure 10.

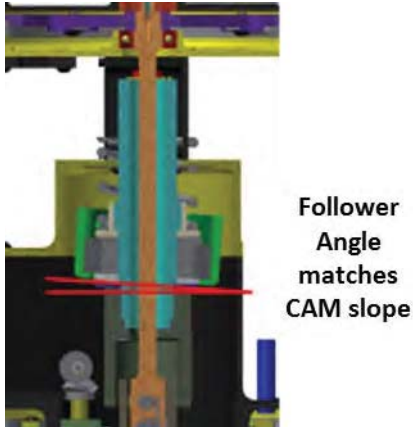

**Figure 10. Sprag (left) [7] and Ratchet (right) mechanisms and corresponding core qualities**

#### RANCOR Percussive Mechanism

Following the heritage of previous Honeybee drills, the RANCOR percussive mechanism was built upon existing successful designs. Mechanically, the percussion depends on employing a rotating cam to lift the follower fixed on the hammer, which then compresses a spring. Once the follower reaches the end of the cam, the spring potential energy is released and the hammer is free to impact the rear end of the drill bit, delivering the 0.6 joules per blow of energy.

A unique feature of the Honeybee CAM follower mechanism is the canted follower concept (Figure 11). This concept utilizes a follower mounted on bearings and tilted to match the slope of the CAM. By using this approach, the interaction between the CAM and follower is primarily rolling contact. However, there is sliding contact at the point where the CAM releases the follower. This approach also increases the operating efficiency of the mechanism. In the IceBreaker drill for instance, the CAM / follower mechanism operated at about 70% efficient [9, 10]. In alternative approaches where the follower is perpendicular to the vertical axis, efficiencies were typically in the 30% to 40% range.

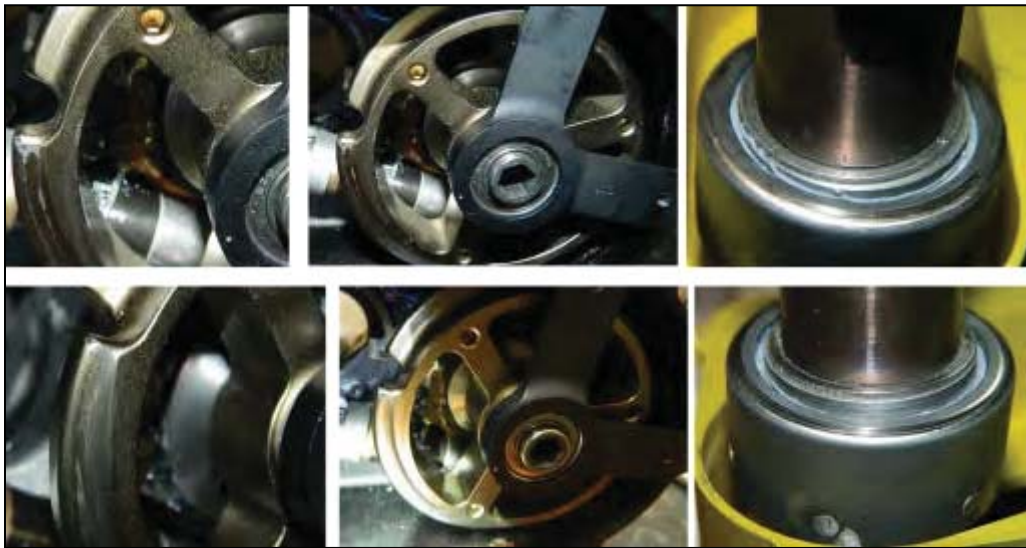

**Figure 11. Canted Follower matches slope of CAM**



**Figure 12. Wear on SASSI CAM**

Another advantage to the canted follower design is an increased life of the CAM / follower mechanism. Two RANCOR units were assembled and tested; a Honeybee and a JPL unit. After over 50,000 percussive cycles with the Honeybee RANCOR unit and over 30,000 percussive cycles with the JPL RANCOR unit, there is little wear on the mechanism (Figure 13). The only obvious wear location is the end of the ramp on the CAM where the follower is released. The follower also had a lubricious coating (Magnaplate Nedox FM-5) that has been worn off on the contact area which was anticipated. At the end of the CAM ramp the Magnaplate Nedox SF-2 plating has been worn off entirely. In designs where the follower is not canted (Figure 12) this plating is removed over essentially the entire contact area of the CAM after only a few thousand cycles.

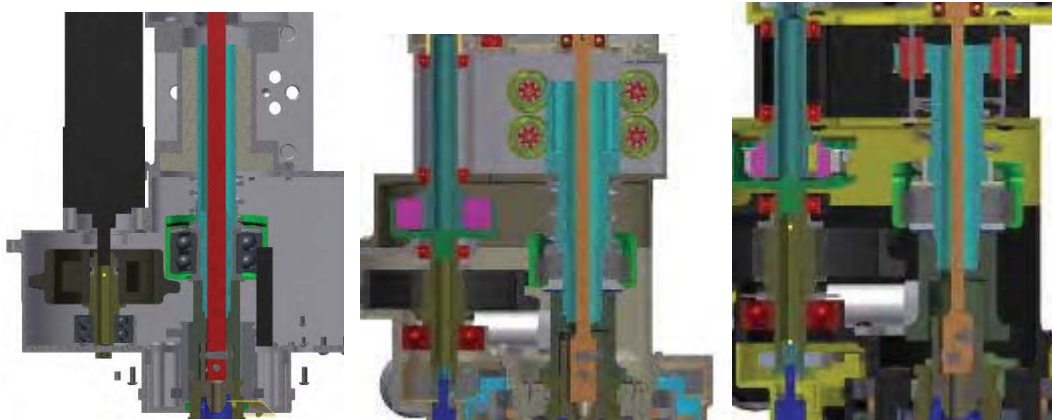

**Figure 13. Images of wear in CAM and Follower for Honeybee unit after 50,000+ cycles (top 3 images) and the JPL unit after 30,000+ cycles (bottom 3 images)**

The method for constraining the percussive hammer had a large impact on the overall mass of the drill. Originally a ball spline was considered to constrain the motion of the hammer mechanism (left of Figure 14). However, this required a large amount of volume and added a large amount of mass. For the percussive cam system to work, a fixed amount of vertical travel of the hammer is required. The volume



due to this travel is fixed; however, the height of the linear slide mechanism can be reduced to only accommodate the required stroke plus some margin.



**Figure 14. Image of evolution of the hammer assembly. Initial concept on the left and final design on the right**

To reduce the mass of the hammer assembly, an alternative for the ball spline was sought. The first alternative approach considered, took inspiration from the chuck roller mechanism. This concept utilized 4 rollers to constrain a custom shaft to axial motion only (center of Figure 14). Due to the complexity of the mechanism and concerns over holding tolerances another alternative mechanism was designed. The final iteration of the design involved two linear bearings (right of Figure 14), which were later replaced by SAE 841 Bronze journal bearings. This is because the linear bearings did not prove durable enough to handle the shock loads of the percussing hammer. This design ended up being the most compact and had the greatest impact in mass reduction of all the designs considered for constraining the hammer motion.

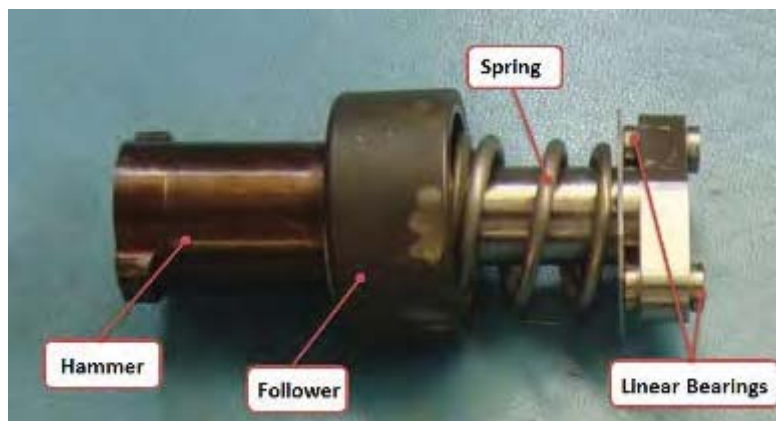

**Figure 15. Hammer Sub Assembly**

Another unexpected failure was the spring responsible for generating percussive energy (Figure 15). The original spring selected for the mechanism was a 303 Stainless Steel compression spring. Failure of the spring occurred towards the end of an extended test of 2 hours (typical tests would run for 10 min to 15 min). Testing conditions were earth ambient temperature and pressure. The spring selected had a free length of 2.54 cm, 2.78-cm outside diameter, a wire diameter of 0.285 cm and 4.1 coils and the designated part number LC112M00S. In the RANCOR application, the spring was constrained by its inside diameter against the fixed, steel backed aluminum housing and the reciprocating follower on top of the drill's hammer. The spring carried an initial preload of 13.9 N due to its compression of 0.081 cm. At maximum compression, caused by the cam lifting the follower, the spring exerted 147.5 N of force under

0.864 cm of compression. At its release, this spring was calculated to provide 0.63 J of energy. The cam operated at 1400 RPM; lifting the follower and subsequently the spring once per revolution, the operation frequency of the spring was 23.33 Hz. Critical frequency of the spring was calculated to be 517 Hz [6]. This is more than 15 to 20 times the operating efficiency which is typically recommended for compressive springs. The Gerber method was used for calculating spring fatigue life [6]. Fatigue analyses concluded the spring should last above  $10^7$  cycles. However, after about 250,000 cycles, less than  $1/40^{\text{th}}$  the calculated design life of the spring, failure occurred.

Since no material certification was requested at the time of purchase of the springs, it is difficult to trace the pedigree of the failed spring. Contacting the manufacturer, Lee Spring, post failure investigation revealed the springs were manufactured in either China or Mexico from a 300-series stainless steel, out of cold drawn stock as according to ASTM A313. The spring also underwent stress relief between 315 - 371 °C after forming and had not been shot peened.

Potential reasons for failure were classified into operation or manufacture. Initial reasons investigated for the spring failure were thought to relate to low cycle failure since initial calculations indicated the spring should have a much longer cycle life than what was measured in testing. High cycle failure is typically caused by subsurface failure from inclusions and low cycle failure, such as perceived in this case, is a symptom of surface imperfections, or surface scratches [8]. Since the operational environment conditions did not exceed the spring's specifications, handling and assembly of the spring were looked at. The possibility of additional surface scratches during assembly was not ruled out. Magnified inspection of the spring under stereo microscope did not indicate any noticeable surface scratches, though a defect as small as 40  $\mu\text{m}$  in length (and hence difficult to see without the use of a Scanning Electron Microscope) could cause fracture initiation. A close up of the fractured surfaces is shown in Figure 16. The granular area in the image indicates brittle fracture. The fracture was at 45 degree (Figure 17) and hence followed the maximum principal stress plane. It should be noted that the gold material shown in Figure 16 is contamination from a bronze sleeve that had started to wear during this 2 hour test.

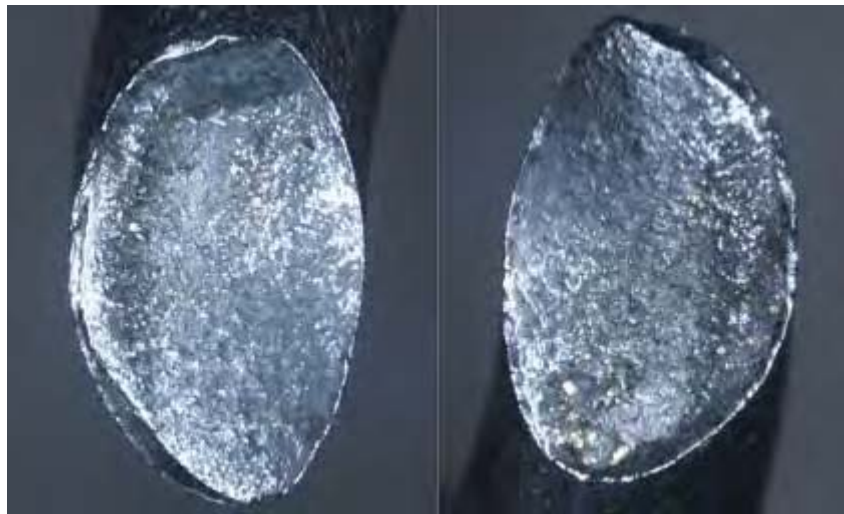

**Figure 16. Enlarged imaging of the fracture. Actual wire diameter is 0.285 cm. Side one of the fracture (left). Side two of the fracture (right).**

## Testing

Two RANCOR drills were built to support this effort. These units are referred to as the Honeybee Support unit and the JPL unit (Figure 18). During the testing phase, two distinct changes to the system were made that impacted the performance of the drill. The first was changing the motor planetary gearhead assembly to provide an increased auger velocity. This change more than doubled the rate of penetration (ROP) in most cases which helped to reduce the overall cycles on the actuator. Interestingly, the number of percussion and auger cycles remained relatively constant. The second change was switching from the sprag overrunning clutch to a ratchet design. This change improved the core grade from primarily D and F grades (generally meaning several fragments and reassembly of core stratigraphy is not obvious as shown in the left of Figure 10) to mostly A, B, and C grades (generally cores that are in-tact or in only a few fragments with a stratigraphy that can be reconstructed as shown in the right of Figure 10). In general, the JPL drill had lower quality cores. This is likely because this system was not positioned well with respect to the linear stage. That is, the drill bit axis and linear deployment stage axis had some noticeable angular misalignment in the mounts to the deployment stage. Therefore the drill bit was penetrating at an angle. Selected telemetry from these lab tests are shown in Table 1.



**Figure 17. Post failure spring, side 1 on the left, side 2 on the right. An approximate 45 degree failure to the surface of the spring corresponds with the maximum principal stress plane.**

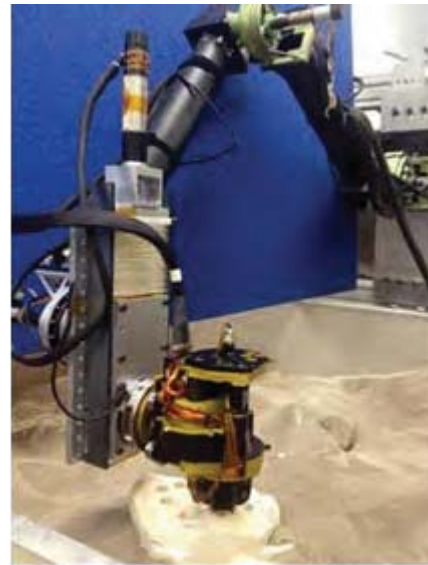

**Figure 18. Lab Testing at Honeybee with the Honeybee Support unit (left) and the JPL delivered unit (right).**

**Table 1. Selected Drill Telemetry from Controlled Laboratory Tests. (Tests marked with an \* were tests in a brown Gypsum. All other tests were in Indiana Limestone. Test 015 is marked with a \*\* because the core breakoff was in the wrong position which resulted in a very poor core grade.)**

Test	Drill	RPM	Sprag / Ratchet	ROP (mm/s)	WOB (N)	Energy/core (Whr)	Motor Cycles	Percuss Cycles	Core Grade
001	HBR	99	Sprag	0.94	39	2.07	168662	3182	D
002	HBR	100	Sprag	0.64	26	2.78	253687	4787	F
003	HBR	100	Sprag	0.56	27	3.19	293248	5533	F
004	HBR	100	Sprag	0.51	27	3.52	331758	6260	C
005	HBR	100	Sprag	0.41	25	4.21	411291	7760	F
006	HBR	100	Sprag	0.49	28	3.91	360050	6793	D
007	HBR	179	Sprag	1.20	37	3.46	146721	5059	F
008	HBR	179	Sprag	1.26	38	3.35	142357	4909	F
009*	HBR	179	Sprag	1.38	36	2.82	116164	4006	D
010*	HBR	179	Sprag	1.39	36	2.82	124202	4283	D
011*	HBR	178	Ratchet	1.24	36	2.37	109073	3761	A
012*	HBR	179	Ratchet	1.26	40	3.13	141429	4877	B
013	HBR	179	Ratchet	1.12	40	3.46	155186	5351	C
014	HBR	179	Ratchet	0.89	40	4.02	189509	6535	C
015**	HBR	179	Ratchet	0.78	40	4.56	222700	7679	F
016	HBR	179	Ratchet	0.81	41	4.42	208367	7185	A
017	HBR	179	Ratchet	0.90	39	3.85	188187	6489	C
018	JPL	179	Ratchet	1.15	37	3.26	149220	5146	A
019	JPL	179	Ratchet	1.01	39	3.44	167460	5774	D
020	JPL	179	Ratchet	0.88	39	3.78	198538	6846	D
021	JPL	179	Ratchet	1.04	37	3.48	173618	5987	A

### Lessons Learned

A number of useful lessons were learned from the design and testing of the RANCOR drill. As with any design, there is still room for improvement, but in the end the drill was more than capable of performing coring tasks in medium to low strength rock targets. Also as requirements for Mars Sample Return (MSR) mature, there may be more mass and volume available to the drill design that can be utilized to increase the reliability and robustness. Lessons learned from the RANCOR drill include the following:

1. In this case, the cost and simplicity of an off-the-shelf sprag clutch versus the design and build of a custom ratchet and pawl system led to the decision to use the sprag clutch. Although there was nothing functionally wrong with the sprag in this design, it enabled a degree of freedom that should have been locked out during the release of the hammer on the RANCOR. Therefore, the sprag mechanism was replaced with a ratchet and pawl system. The result was a large improvement in core quality (from D through F grades to A and B grades).
2. If a single drill bit is to be used for multiple holes (i.e. 10, 20, 30), care must be taken to design a proper kinematic constraint for rotation of the inner breakoff tube with the outer auger tube. Also seals should be used to prevent rock cuttings from migrating between the breakoff and auger tubes. In the region near the cutting edge of the bit, there should be sufficient clearance between the breakoff tube and auger tube to allow rock cuttings to flow in and out more freely. If there is not sufficient clearance, the cuttings will pack up and seize rotation between the breakoff and auger axes. This can happen after drilling only a few cores if spacing is not sufficient and seals are not in place.

3. Using rollers in the drill chuck to constrain the drill bit offers many benefits over traditional spline joints. These benefits are as follows:
  - a. Rotating joints are much easier to protect from dust than linear spline type joints.
  - b. When docking with a bit, the relatively large rollers on the RANCOR chuck helped account for some misalignment between the drill chuck axis and the axis of the docked drill bit.
  - c. The rolling interface between the chuck and the bit is a highly efficient joint that enables an efficient transfer of the percussive energy to the bit. Also, this interface greatly reduces the force required to remove the drill head from the drill bit if there is a large side load present on the system.
  
4. As with all drill bit designs, the grade of carbide makes a big difference in the life of the bit. In general, at low percussive energies, harder, more brittle carbide can be used to extend the life of the drill bit by reducing wear. In the case of the RANCOR drill bit design, the harder carbide performed well in relatively soft rocks (~40-MPa UCS). However, when drilling the ~120-MPa Saddleback Basalt, these cutters fractured and became less effective. Therefore, for the RANCOR drill, softer grade carbide is preferred. It is recommended that a number of carbide grades should be tested to determine the optimum combination of hardness and toughness for 0.6 J/blow hammer system in hard rocks. It should be noted that for alternative sample caching architectures, where the bit is used only once and cached together with a core sample, the bit life is less of a concern and hence softer carbide could be selected [11].

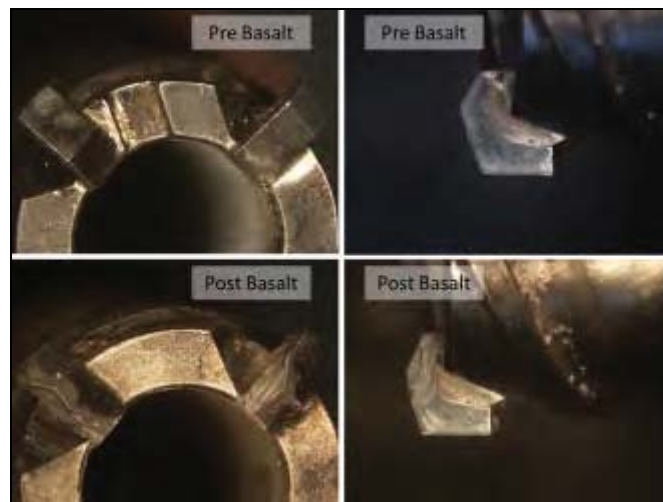

**Figure 19. RANCOR drill bit with a harder, more brittle, rotary grade carbide before and after drilling into Saddleback Basalt.**

5. For all spring loaded percussive designs, it's important to life test the percussive mechanism using components from a batch process with certification. Spring analyses for the RANCOR concluded that the original stainless steel spring selected for the RANCOR drill should have survived more than  $10^7$  cycles. However, this spring failed on the support unit after only 250,000 cycles. Currently the music wire spring that replaced the stainless steel spring is at greater than 375,000 cycles.
  
6. Using a canted or sloped follower for the hammer mechanism (i.e. follower is tilted to match the slope of the cam) is an ideal solution for the percussive mechanism. This type of solution has now been implemented on its third Honeybee drilling system and has performed efficiently on all systems. When compared to a more traditional follower design where the follower is perpendicular to its axis of travel, the canted follower is about twice as efficient and the wear in the mechanism is significantly reduced.

## Conclusions

A 3-kg rotary percussive core acquisition drill was developed under this effort. The system consists of two actuators and was able to drill cores, break and capture cores, and actively mate and de-mate with drill bits. This design fits within the JPL-derived IMSAH architecture and has mass, volume, power, and energy specifications that would enable deployment and operation from an MER or MER+ class rover or larger. Results from tests performed with this RANCOR drill proved that this design is fully capable of meeting the goals of a MSR mission. However, there were lessons learned here that would help to improve future designs of this type of drill and future drill systems. Also, much more testing is necessary to help ensure the life of the components within the drill will be sufficient for providing up to 30 cores plus margin for a MSR mission. Tests also should be performed at Mars atmospheric pressure.

## Acknowledgements

This work was funded by the NASA Small Business Innovative Research (SBIR) Program. We owe our sincere thanks and appreciation to the NASA SBIR program and the COTRs: Paul Backes, Kristo Kriechbaum, Kerry Klein, and Lori Shiraishi.

## References

1. S. Hayati, Technology Planning for Future Mars Missions, MEPAG, 29-30 July 2009
2. Chu P., J. Spring, K. Zacny, ROPEC – ROTary PERcussive Coring Drill for Mars Sample Return, 42nd Aerospace Mechanisms Symposium will be May 14-16, 2014 in Baltimore, Maryland.
3. K. Klein, et al. "Rotary Percussive Sample Acquisition Tool (SAT): Hardware Development and Testing." Proceeding of the 41<sup>st</sup> Aerospace Mechanism Symposium, Jet Propulsion Laboratory, May 16-18, 2012.
4. Backes, P.; Lindemann, R.; Collins, C.; Younse, P.; An integrated coring and caching concept, Aerospace Conference, 2010 IEEE, 10.1109/AERO.2010.5446985
5. Myrick., T., US Patent No. 6,550,549, "Core Break-off Mechanism"
6. Joseph E. Shigley and Charles R. Mischke. *Mechanical Engineering Design Sixth Ed.* McGraw-Hill, 2001.
7. GotTransmissions.com. (2014, January 3). *Automatic Transmission Sprag Clutches Defined.* <http://www.gottransmissions.com/blog/transmission-components-technology-defined-explained/automatic-transmission-sprag-clutches-defined>.
8. Pytel et al. "Fatigue behavior of helical compression springs at a very high number of cycles – Investigation of various influences." *International Journal of Fatigue* (2013).
9. Paulsen, G., K. Zacny, M. Szczesiak, C. Santoro, B. Mellerowicz, J. Craft, C. McKay, B. Glass, A. Davila, M. Marinova. *Testing of a 1 meter Mars IceBreaker Drill in a 3.5 meter Vacuum Chamber and in an Antarctic Mars Analog Site.* AIAA SPACE 2011 Conference & Exposition, Long Beach, September 26-29, 2011
10. Zacny K., Paulsen G., McKay C. P., Glass B., Davé A., Davila A.F., Marinova M., Mellerowicz B., Heldmann J., Stoker C., Cabrol N., Hedlund M., and Craft J. *Reaching 1 m Deep on Mars: The Icebreaker Drill.* *Astrobiology.* December 2013, 13(12): 1166-1198. doi:10.1089/ast.2013.1038.
11. Zacny, K., J. Wilson, P. Chu, and J. Craft, Prototype Rotary Percussive Drill for the Mars Sample Return Mission, Paper #1125, IEEE Aerospace conference, 5-12 March 2011, Big Sky, Montana.