

Development of a Water Recovery System Resource Tracking Model

Joe Chambliss¹, Imelda Stambaugh², Miriam Sargusingsh³, Sarah Shull⁴
NASA Johnson Space Center, Houston, TX, 77058

and

Michael Moore⁵
L3 Communications, Johnson Space Center, Houston, TX, 77058

A simulation model has been developed to track water resources in an exploration vehicle using Regenerative Life Support (RLS) systems. The Resource Tracking Model (RTM) integrates the functions of all the vehicle components that affect the processing and recovery of water during simulated missions. The approach used in developing the RTM enables its use as part of a complete vehicle simulation for real time mission studies. Performance data for the components in the RTM is focused on water processing. The data provided to the model has been based on the most recent information available regarding the technology of the component. This paper will describe the process of defining the RLS system to be modeled, the way the modeling environment was selected, and how the model has been implemented. Results showing how the RLS components exchange water are provided in a set of test cases.

Nomenclature

<i>ACG</i>	=	Automatic Code Generation
<i>ALSSAT</i>	=	
<i>ARM</i>	=	Asteroid Retrieval Mission
<i>ARS</i>	=	Air Revitalization System
<i>ARV</i>	=	Asteroid Return Vehicle
<i>BSTA</i>	=	Brine Storage Tank Assembly
<i>BVAD</i>	=	Baseline Values and Assumptions Document
<i>CDRA</i>	=	Carbon Dioxide Removal Assembly
<i>CDS</i>	=	Cascade Distillation System
<i>CFR</i>	=	Carbon Formation Reactor
<i>CHX</i>	=	Condensing Heat Exchanger
<i>CPU</i>	=	Central Processing Unit
<i>DOUG</i>	=	<i>Dynamic Onboard Ubiquitous Graphics</i>
<i>DSTA</i>	=	Distillate Storage Tank Assembly
<i>DTO</i>	=	Detailed Test Objective
<i>EAM</i>	=	Exploration Augmentation Module
<i>EC</i>	=	Crew and Thermal Systems Division of NASA JSC
<i>ECLSS</i>	=	Environmental Control and Life Support System
<i>EDGE</i>	=	<i>Engineering DOUG Graphics for Exploration</i>
<i>EPS</i>	=	Electrical Power System
<i>ER</i>	=	Automation and Robotics Division of NASA JSC

¹ Systems Engineer, Crew and Thermal Systems Division, 2101 NASA Parkway/EC2.

² Lead for Analytical Studies, Crew and Thermal Systems Division, 2101 NASA Parkway/EC2.

³ Life Support Systems Engineer, Crew and Thermal Systems Division, 2101 NASA Parkway/EC2.

⁴ Lead, ECLSS Technology Development Group, Crew and Thermal Systems Division, 2101 NASA Parkway/EC3.

⁵ Systems Engineer, Software, Robotics, & Simulation Division, 2101 NASA Parkway/ER.

<i>EVA</i>	=	Extravehicular Activity
<i>FOST</i>	=	Forward Osmosis??
<i>GPU</i>	=	<i>Graphics Processing Unit</i>
<i>HIDH</i>	=	Human Integrated Design Handbook
<i>HMC</i>	=	Heat Melt Compactor
<i>ISS</i>	=	International Space Station
<i>LDRO</i>	=	<i>Lunar Distant Retrograde Orbit</i>
<i>LPCOR</i>	=	Low Power CO2 Removal
<i>MMSEV</i>	=	Multi-Mission Space Exploration Vehicle
<i>MOD</i>	=	Missions Operations Directorate of NASA JSC
<i>OGA</i>	=	Oxygen Generation Assembly
<i>OOP</i>	=	Object Oriented Programming
<i>PCS</i>	=	Pressure Control System
<i>PWD</i>	=	Potable Water Dispenser
<i>RLS</i>	=	Regenerative Life Support
<i>RTM</i>	=	Resource Tracking Model
<i>SAFER</i>	=	<i>Simplified Aid For EVA Rescue</i>
<i>SH</i>	=	Surface Habitat
<i>SPE</i>	=	Solid Polymer Electrolyzer
<i>SR</i>	=	Sabatier Reactor
<i>SRMS</i>	=	Shuttle Remote Manipulator System
<i>SSRMS</i>	=	Space Station Remote Manipulator System
<i>TCCS</i>	=	Trace Contaminant Control System
<i>TCS</i>	=	Thermal Control System
<i>UPIX</i>	=	Urine Processing Assembly (UPA) Precipitation Prevention Project (PPP) Ion Exchange (IX) Column
<i>VCD</i>	=	Vapor Compression and Distillation
<i>Visio</i>	=	a diagramming and vector graphics application; part of the Microsoft Office family
<i>WPA</i>	=	Water Processor Assembly
<i>WSTA</i>	=	Water Storage Tank Assembly
<i>WWTA</i>	=	Waste Water Tank Assembly

I. Introduction

MOST exploration mission and habitat designs take advantage of the mass savings and efficiency of operations that a RLS system will provide. The interaction between RLS subsystems involves many interdependencies both within and between subsystems. To understand such interdependencies in a vehicle using a RLS, an integrated model of the architecture and the interconnections of components was needed. The RTM has been developed as the first model of an integrated RLS that is capable of tracking the need, use and regeneration of resources in an exploration vehicle during a simulated mission.

This modeling effort was initiated in support of the NASA Advanced Exploration Systems (AES) project for study of an Exploration Augmentation Module (EAM). Development of the RTM also supports AES projects for Water Recovery Systems (WRS) and Air Revitalization Systems (ARS).

II. Resource Tracking Model Features

Features of the modeling environment that were considered important and useful were:

- 1) Easily captured system architecture – The RTM creates connections between components based on Visio (ref 1) schematics
- 2) Object Oriented Programming (OOP) – The RTM uses OOP to establish and encapsulate the performance of each component into a modular software representation. The object for each component can be exchanged with the object of a different technology or vintage of the component without having to significantly change the software representation of the entire system.
- 3) Establish component objects for all component types that are being considered for exploration vehicles – RTM addresses the types of components being considered for advanced deep space missions. This approach allows alternate architectures to be modeled by changing the schematic of the vehicle systems

- 4) Easily integrated into higher level simulators – the RTM has been integrated into a vehicle functioning simulator for a deep space simulator that “crew” can fly for simulated missions
- 5) Keep the level of simulation high so that the integrated functions of the RLS can be run quickly and so the RTM can be integrated into other simulations. The RTM uses performance data for technology at an inlet and outlet level but does not do analysis within a component for the physics going on within the component. This approach results in great model performance but limits off-nominal and contingency case capabilities. RTM is as capable as the performance data used to develop its components.

A. Modeling Data Sources

The RTM models the performance of a set of ECLSS equipment based on component operational or test data. Performance of the equipment is established based on operational data from ISS or on the most current data on advanced technologies (references are given).

The RTM configuration of systems and subsystems was chosen to be representative of a regenerative ECLSS using ISS proven technologies combined with promising new technologies (technologies that have established performance data). The suite of equipment included in the initial RTM was chosen to address technologies that are expected to be considered for long duration exploration missions. That set of equipment can be changed relatively easily for simulation of a more simplified approach to ECLSS or as new technology reaches maturity.

The RTM addresses crew functions using HIDH (Ref 1) defined metabolic rates and processes and combined with the exploration Logistics database for crew needs such as food and packaging that results in trash waste products (Logistics Model v2.5 Final 9-3-14 – Ref 2). That data is consistent with the recently released Baseline Values and Assumptions Document (BVAD) (Ref 3). Crew functions include food and water intake, respiration, food waste generation and crew metabolic waste generation. Crew metabolic rates are varied based on a schedule developed for the simulated crew that includes nominal, sleep, and exercise periods. Additionally, a daily crew restroom use schedule is assumed. Habitat Pressure Control System (PCS - O₂ and N₂ supply) and Atmospheric Revitalization System (ARS - CO₂, H₂O, and heat removal) are defined based on ISS technologies. The oxygen generation is via ISS electrolysis technology.

To recover O₂ from CO₂, a Sabatier Reactor (SR) with performance based on ISS processes is assumed. Cabin Air humidity removal is done via a Condensing Heat Exchanger (CHX) with performance defined via the ISS CHX. Cabin CO₂ removal and performance is simulated via an ISS Carbon Dioxide Removal Assembly (CDRA) (ref 4). Hydrogen for the SR is provided via the O₂ producing Oxygen Generation Assembly (OGA) with performance as in ISS OGA specification (ref 5). Specification water electrolysis rates are used instead of ISS averages because exploration missions will not be as tightly constrained by orbital cycles that influence power use. No storage of H₂ is included (similar to how the ISS ECLSS functions to interact with the SR commercial Demonstration Test Objective (DTO)).

Supporting functions of food processing, handling food wastes and human wastes are simulated according to operations representative of exploration missions. The amount of trash to be processed is defined in the habitation team logistics model (ref 2) for trash products that are expected to be generated during a long duration Mars mission.

The function of the toilet is based on ISS toilet and operations technology to collect solid and liquid waste products, and pretreat urine.

New technologies are used for urine processing and recovery of water from cabin waste products based on promising Cascade Distillation System (CDS) (ref 6) and Heat Melt Compactor (HMC) (ref 7) technologies. Water recovery from brine is included based on the Brine Residual in Containment (BRIC) (Ref 8) technology development. Trash that contains water is assumed to be processed by the HMC.

The Water Processing Assembly (WPA) filtration and ion removal system of ISS is assumed for producing potable water.

The RTM has capabilities to include simulation of Extravehicular Activity (EVA) events. However those capabilities are currently under review and RTM test cases do not include EVA simulations. EVA systems interactions with an exploration vehicle RLS are important but not currently established. When EVA is addressed as an integral part of an exploration RLS, the interaction between the habitat RLS and EVA systems will be critical for exploration missions with significant EVA.

In the ISS, the WRS includes the potable water tanks, the toilet including pretreat subsystem, a Vapor Compression Distillation (VCD) system, and the WPA. The cabin CHX provides water directly to the WPA and the VCD product water goes to the WPA. WPA product water is used for drinking, for toilet flush and to provide water for electrolysis in the OGA.

The RTM includes the ISS functions but replaces the VCD with the CDS and adds the BRIC and HMC for the integrated exploration ECLSS. CDS distillate water goes to the WPA and Brine goes to the BRIC. BRIC water

recovered is distillate but it is thought that there may be volatiles or other impurities in the BRIC distillate product. Therefore the BRIC product water is plumbed to the CDS waste water tank to be reprocessed by the CDS. HMC product water is a distillate and feeds the WPA. Distillate water from the CHX, CDS or HMC is thought to be pure enough to use as flush water for the toilet.

B. Functional Schematic Development

RTM development first focused on the utility of existing system information and connectivity between simulation programs. It was determined that schematics that use Visio (ref 9) can be used in other programs such as SysML (ref 10) and the JSC ER developed Trick/GUNNS (ref 10) program to establish simulation connections.

Early in RTM development, plans were to use existing ISS ECLSS schematics as the starting point for the RTM so that all the valves, tanks and ancillary equipment that the operational ISS system includes would be captured. However, working with the ISS ECLSS community, it was determined that the detail in the ISS ECLSS schematics is not available in a form that is recognizable by other programs (like Visio).

The JSC ECLSS community has used Microsoft Visio to generate schematics for many systems. At the time that the RTM development was initiated, an integrated ECLSS schematic had just been released as part of a study of the Mars Habitat ECLSS (Ref 12). That schematic contained most of the ISS ECLSS components but added many advanced ECLSS technologies to more completely close the system (closure minimizes waste products and venting to the surrounding environment and minimizes mass). The Mars Habitat schematic was evaluated for technologies that could be used in the RTM and many functions represented were common. Therefore the Mars Habitat schematic was chosen as the starting point for generating the RTM schematic.

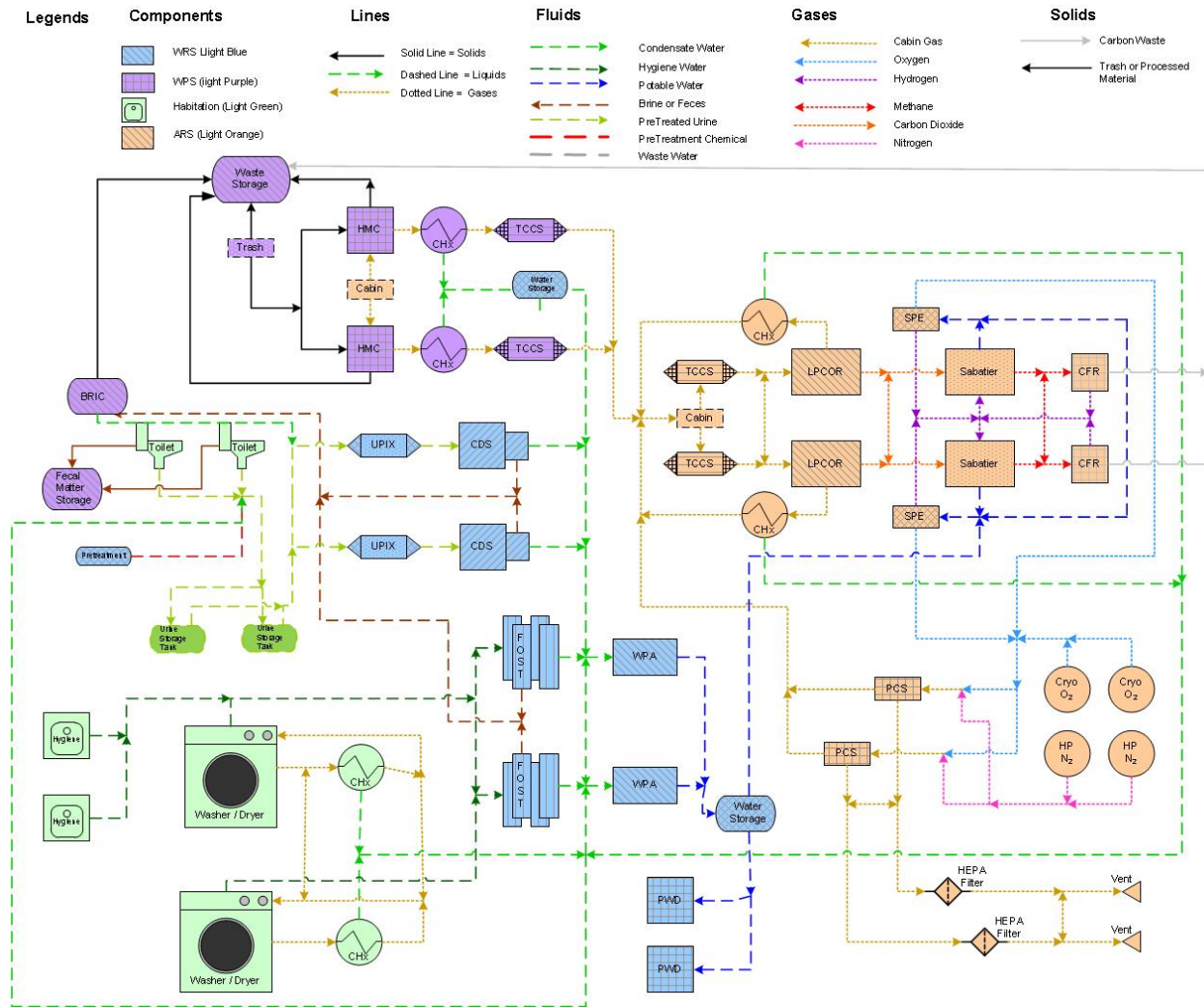

Figure 1 SH Mars schematic

The Mars Habitat ECLSS contained redundancy thought to be needed for such a mission. For the initial RTM that redundancy was not included since the basic functions could be modeled without the complexity of failure simulations that would employ redundant components. Several advanced technologies (washer/dryer, Hygiene (shower), FOST and LPCOR) were not mature enough to include in the RTM because performance data was not available. The resulting RTM schematic in Figure 2 is simplified versus the Mars SH schematic. The Visio version of the schematic in Figure 2 was provided to JSC ER Trick/GUNNS analyst Michael Moore and was used to create the RTM model.

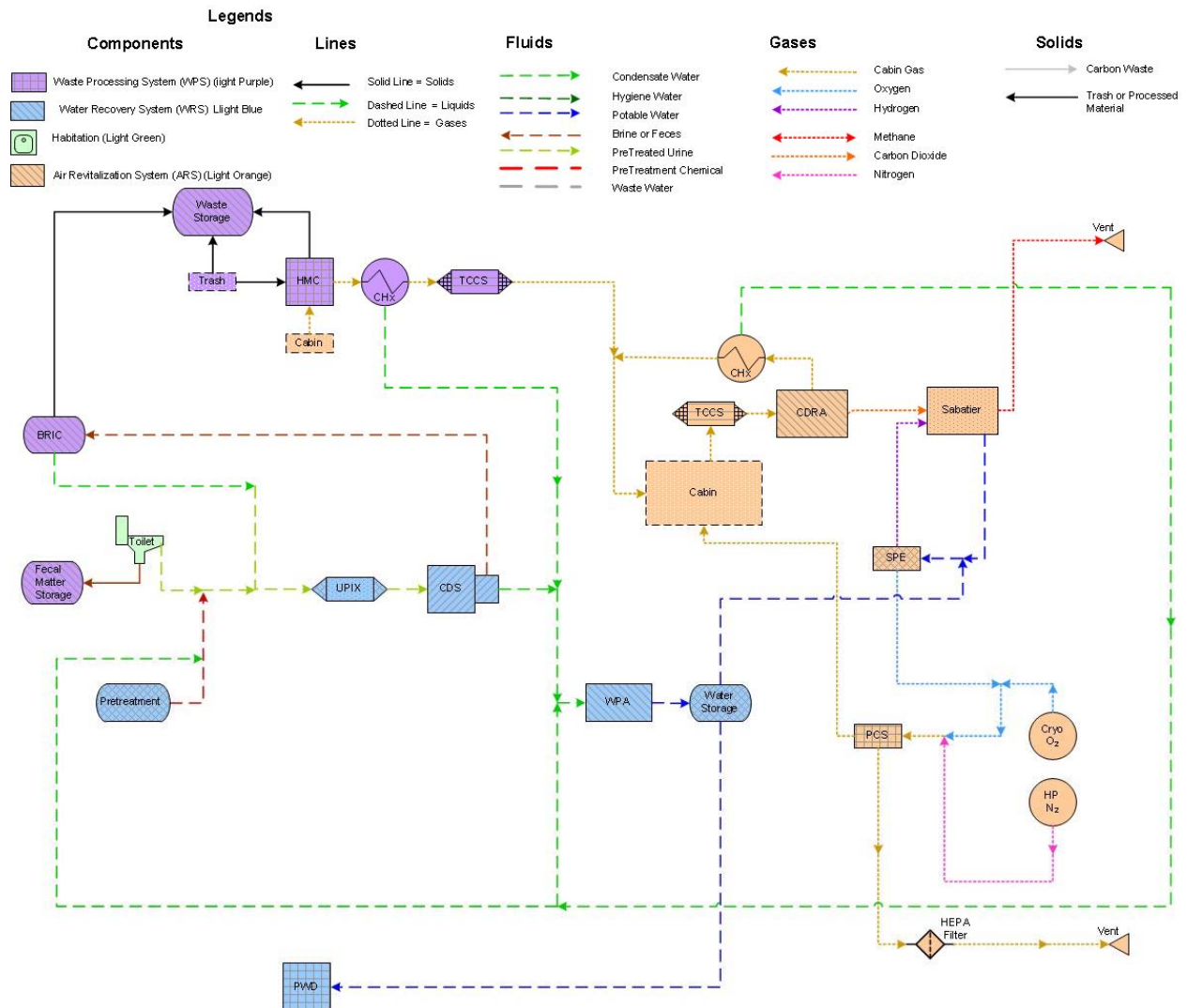

Figure 2 Integrated RLS used in the RTM

C. RTM program consideration and synergy

Initial concepts for simulation leading to the capability to simulate the integrated ECLSS performance considered programs recently used for ECLSS evaluations such as Easy5 (Ref 13), SysML (Ref 10), ALSSAT (ref 14), G189A (Ref 15) and Thermal Desktop (ref 16). The extensive infrastructure but limited fluid property capabilities of Easy5 and SysML would have made a simulation model using that program limited. The ALSSAT program has the technology functional information needed but is only designed for steady state (SS) assessments of technology variations. SysML is capable of modeling system requirements, behavior, structure, and parametrics, but requires a separate engine for performing simulations. The G189A program has not been updated recently and thus its capabilities to simulate advanced ECLSS components would have needed to be augmented. Thermal Desktop is better suited for dominantly thermal problems.

Interactions between JSC ER and EC were underway during the summer of 2014 to simulate parts of the Exploration Augmentation Module (EAM); so the ER developed simulation program Trick and its augmentation for power, thermal, and ECLSS simulations, GUNNS, were also considered. The ER team was to develop a vehicle simulation for the Exploration Augmentation Module (EAM) project (ref 17) to include ECLSS in the vehicle simulator they were developing using Trick/GUNNS. Thus a synergistic connection between the EC effort to develop a RTM and the ER effort to develop a vehicle simulator was initiated. EC would provide information to include in the Trick/GUNNS simulator and ER would implement the performance and operational logic in the RTM for the EAM. ER would then operate the RTM to simulate exploration missions.

The Trick/GUNNS simulator is compatible with Visio and can take objects from Visio to develop a Trick/GUNNS model. The resulting Trick/GUNNS RTM simulator can operate separately to meet the needs of the ECLSS

community for simulation of the operation of the integrated ECLSS. The RTM is also used in integrated vehicle simulations to simulate operation of the EAM in real time and is connected to displays and control system simulators to provide the capability to “fly” the EAM.

{Figure 3 (&4?) Displays and controls for RTM when run within an integrated deep space vehicle simulation }

D. Details on the Trick Simulation Framework and the GUNNS Extension

Trick is a JSC standard simulation environment used for the development and operations of both analysis and real-time human-in-the-loop training simulations (ref 11). A few past examples of Trick in use at JSC include simulations of the following systems: Shuttle Remote Manipulator System (SRMS), Space Station Remote Manipulator System (SSRMS), Simplified Aid for EVA Rescue (SAFER), and recently an ISS training simulation for JSC flight controllers. The simulation applications range from laptop and desktop computer trainers to full scale robotics hardware-in-the-loop facilities and virtual reality systems. Trick provides a data-driven real-time scheduling executive, input processing, data recording, and automatic code generation (ACG).

The RTM uses Trick primarily for its time management, thread management, and data collection mechanisms. The subsystems within the RLS model are separated into individual GUNNS networks and then placed within their own simulation modules. As an example, the ARS would exist within one module, the PCS in another, and the Sabatier Reactor in yet another simulation module. GUNNS acts as the solver for each system represented by its network of components. The Trick simulation definition file is used to schedule how frequently each system is updated in time. Trick then tells GUNNS to update each system at the frequency specified in the simulation definition file. Trick also manages all of the other jobs it might have within a single simulation step (simulation frame). At the end of a simulation frame, interface data is shared across GUNNS networks, and then Trick proceeds to the next simulation frame and repeats the process.

GUNNS is a C++ and Trick compatible software framework used to simulate fluid, electrical, and thermal systems in real-time and faster than real-time applications. It was originally designed to aid in the construction of an ISS vehicle training simulator for flight controllers at JSC. In particular, GUNNS formed the core architecture for the simulation of the electrical, thermal, and life support systems on-board ISS. The size of the ISS system, and the real time simulation requirements pushed the software engineers to design a modeling and simulation architecture that was highly parallelizable. This allowed them to maximize performance by taking advantage of Trick’s thread management and modern multi-core CPUs and GPUs.

GUNNS gives the simulation engineers a mechanism for splitting a large vehicle system like ECLSS into modular subsystems. The developer is given a framework for modeling the subsystem component interactions as a simultaneous system of algebraic equations. The GUNNS solver, in combination with the Trick scheduler and thread management system, allow the developers to execute each separate subsystem on its own processor thread. Interface information sent across the subsystem boundaries is exchanged at the end of a single simulation frame. As long as large systems are split into subsystems at dynamically stable boundaries, this approach allows for an accurate and highly parallelizable approach to systems modeling.

While GUNNS can theoretically be used to model any system that can be mathematically formulated as a linear algebraic system of equations, it has so far found its most prominent applications in the modeling of fluid, electrical and thermal systems. It accomplishes this by using the fluid-electric-thermal analogy. More generally, it captures concepts of capacitance, conductance, flux, and potential. In the world of fluid dynamics, these words are more often stated as volume, flow resistance, flow rate, and pressure differential. Nodal networks of component models (links) form the basis of a GUNNS system representation. This representation resembles the nodal analysis techniques from introductory electrical circuit classes. Introducing the concept of nodes allows a direct mapping of a network representation to an admittance matrix representation. GUNNS simply inverts this matrix at each simulated time step in order to solve for the new node potentials and fluxes.

In the case of the RTM, the fluid aspects of GUNNS were primarily used. This includes fluid properties tables, and often used fluid system component models like pumps, fans, valves, pipes, and tanks. In order to capture the system connectivity in the model, schematics of the system are converted into a GUNNS representation. At the present time, GUNNS comes with a Visio plug-in that allows systems to be built out of common components in a drag and drop fashion. This makes it particularly easy to swap components into and out of the system being modeled. Once complete with a candidate system schematic, the Visio plug-in then parses the drawing and converts it into GUNNS and Trick compatible C++ code automatically. There is also a current effort at JSC to expand this capability into SysML by developing a GUNNS compatible, Magic Draw SysML plug-in. It is currently in the very early stages. For the RTM, SysML drawings of the components were used as a reference towards building a GUNNS compatible model in a manual fashion.

{Figure 5 (?) GUNNS drawing example going from real world schematic to GUNNS compatible representation.}

The Trick and GUNNS combination of tools allows the user to re-size system components from a simulation input file. In many cases, system tweaks can be made and a follow on analysis can be performed without any need to re-compile the simulation executable. Trick also has a built in Monte Carlo framework which can allow the analyst to statistically vary important system sizing parameters and record simulation output in an automated fashion.

E. Using a Trick Simulation to Integrate the RTM Into a Full Vehicle Simulation

At present, JSC's ER branch has several vehicle simulations with the capability of placing candidate vehicle designs in a variety of space environments. Some examples of the current vehicle simulation capabilities include an Orion in a variety of transfer orbits, or Orion docked in a vehicle stack configuration. The MMSEV on the surface of an asteroid, or the surface of a Mars moon. The EAM participating in the ARM with Orion and the ARV. All of these simulations are built on top of the Trick simulation framework, and they employ a variety of Trick extensions to model orbital dynamics, vehicle GN&C, propulsion, and contact physics to name only a few. The simulations also use JSC's DOUG and EDGE graphics packages along with hardware input devices in order to create an immersive 3D simulation experience for users to "fly" these vehicles.

The RTM represents a potential RLS for deep space manned vehicles. It makes sense to evaluate this model in the context of a simulated space vehicle environment. The selection of Trick and GUNNS as the basis for the RTM has made integration with ER's existing deep space vehicle simulations a much easier process. At present, ER is working on a simulation that places an Orion, EAM, and ARV within a LDRO. This simulation will incorporate the work done on the RTM as part of the EAM's RLS. It will combine this system with GUNNS models of EAM's proposed EPS and TCS. All of these systems have simulated interfaces to the spacecraft environment. The goal of the effort is to give systems engineers a view of how candidate system designs perform in an integrated mission. As an example, it may give insight into how and when power can be made available to some of the power hungry RLS components depending upon the specific mission. This could dictate how the RLS is actually operated under that environment. This could change the amount of consumables that you are required to bring. Ideally, the integrated models will provide insight into scenarios that might be very hard to imagine without experimenting with a simulated vehicle with truly integrated systems.

III. ECLSS performance information and mission operations

The RTM has, for the first time, simulated the integrated functions of an advanced regenerative ECLSS for an exploration mission scenario. To accomplish that required establishing a mission timeline that includes the general functions of the crew, and the operation of each of the regenerative ECLSS components.

Since this was the first time such a broad collection of a vehicle systems were integrated together in a mission simulator, many questions had to be addressed. Questions such as how large should the tanks be, what is to be assumed to be loaded in tanks to start a mission; what should drive the sequence of operations of the variety of components; how detailed does the simulation of each component have to be to assure interactions with other components is relatively accurate; what mission scenario should be used to demonstrate and test the RTM

A briefing to the WRS team in early summer of 2014 provided information to the team on how the RTM project was evolving. The team was engaged to establish how the integrated system should function. Many questions were addressed via the interaction with the WRS team. However, other questions crossed team boundaries and operational details were not well established for many component interactions. The strong interaction between technology developers and the Mission Operations Directorate (MOD) teams will occur later for exploration systems. Interactions with the ISS ECLSS community resolved more questions on how ISS systems were operated.

One outcome of the interactions was the finding that the regenerative EAM ECLSS will be similar in functions and thus will require system articles that will be similar to the sizes used on the ISS. Therefore many tanks have used ISS tank sizes as a starting point for the EAM ECLSS.

However, ISS ECLSS operations are different in many ways than those envisioned for the EAM. The ISS has backup in Russian elements that an EAM is not likely to have. The EAM will probably include a higher degree of ECLSS "closure" than ISS achieves because it must function much more independently. Regenerating more waste products via the HMC and the BRIC will lead to a higher percent recovery of waste water. The operation of the Sabatier Reactor (SR) in EAM will be an integral part of the balance of consumables and that balance will be much more important for independently operating exploration habitats.

A. Additional Information Needed for an Integrated RLS Vehicle Simulation

A detailed operational timeline for equipment use during an exploration mission has not been developed. To simulate mission operations of the RLS, the RTM developers had to develop operational logic and initial design information. The added information includes:

- 1) Timeline of crew activities,
- 2) Tank sizes for a variety of tanks,
- 3) Routing of fluids between tanks and components,
- 4) Sequencing of equipment operations,
- 5) Interdependencies of component operations
- 6) Operation that provides the force to move fluids thru the systems.

The number of crew targeted for many exploration missions is similar to the number of crew that ISS equipment is designed to support. Therefore the tank sizes of ISS were used both for commonality with existing proven equipment and to be representative for a vehicle designed for exploration. The initial RTM runs assume the crew size is 4.

The metabolic rates, supporting food and water supplies and consumable goods, trash generated, the portion of that trash that can be used in the HMC were all sized for a crew of 4. The nominal use of such supplies and the resulting metabolic products were defined based on the June 2014 Human Integrated Design Handbook (HIDH) (ref 1).

To test the RTM a basic week of operations was defined. Simulating a basic crew week provides insights into the normal exchange of fluids (and gases) that will take place during an exploration mission. The basic week establishes the crew routines for daily activities including: 1) sleep, 2) nominal activities, 3) exercising, 4) use of the commode, 5) consumption of food and drinks, 6) generation of trash. The HIDH combined with the Logistics Database (ref 2) was used to provide values related to crew activities. A representative timeline of activities was developed for the crew to time processes (Figure 3).

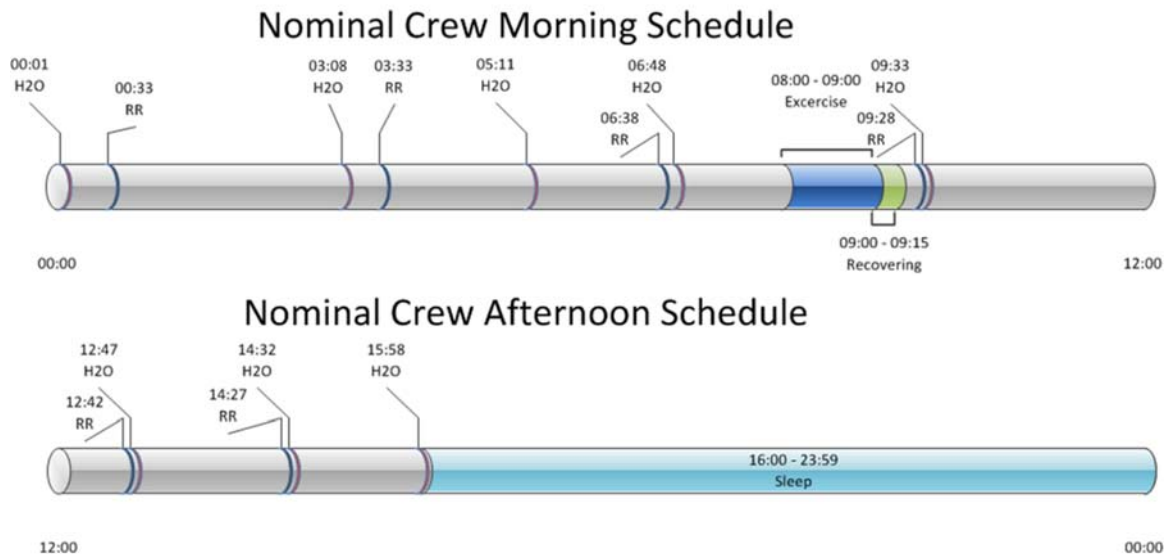

Figure 3 The Crew Timeline of activities for a nominal week of exploration operations.

B. Logic for operating the commode, CDS and BRIC

The logic developed for use of the commode started with the crew use timing shown in figure 3. For each commode use, the RTM assumes that the ISS derived system will operate a fan/separator to provide the suction to draw urine, flush water and pre-treat chemicals thru a system that feeds the CDS waste water storage tank assembly (WSTA). That flow is assumed to be processed by a Urine Processing Assembly (UPA) Precipitation Prevention Project (PPP) Ion Exchange (IX) Column (UPIX) prior to it going to the CDS WSTA to remove excessive Calcium. When the CDS WSTA quantity exceeds its limit it is assumed to be full and CDS operations are initiated. CDS operations continue

until the waste water tank quantity lower limit is reached, then the CDS is deactivated. Each CDS operation results in the inlet pretreated urine being pulled thru a UPIX to remove excess minerals, then distillate is put into a Distillate Storage Tank Assembly (DSTA) and brine created during that operation is placed in the CDS Brine Storage Tank Assembly (BSTA). When the DSTA level reaches its upper limit, the DSTA is emptied into the WPA Waste Water Tank Assembly (WWTA). When the BSTA exceeds a full limit, the BSTA connection to the BRIC is opened and the brine is processed to recover water which is routed to the WSTA to be reprocessed via the CDS. The CDS provides the pumping needed to move distillate and brine via pitot forces.

Solid waste products from the commode and the BRIC are tracked by the RTM as waste products that are stored as solid waste.

1. Logic for HMC operations

The HMC operations are also defined related to crew operations. The logistics model of products used and waste generated defines the variety of waste products that result from crew activities. HMC developers target a subset of the solid and liquid waste products produced by the crew for processing by the HMC. Testing has established that the representative mix of waste products that the HMC can process will have some water and HMC operations can recover a portion of that water in the form of distillate. The crew activity timeline establishes, that after breakfast each day, a crew will load the HMC with material that it can process. Then the HMC will be activated and will spend much of the day processing that waste into a stabilized block of waste and distilled water. The distilled water is pumped to the WPA WWTA by the water separator included in the HMC.

2. Logic for WPA Operation

The WPA is assumed to be off until the Waste Water Tank Assembly ORU (WWTA) reaches a full state (assumed to be 95% full). The WPA is then operated to purify distillate until the WWTA reaches empty (5%). Potable water is plumbed to Water Storage Tank Assemblies (WSTAs). 3 WSTAs are assumed for the RTM so that water quality can be verified before it is used and to provide water for potential contingencies. The RTM assumptions for operation of 3 WSTAs is that Tanks 1 and 2 will start full and tank 3 should start at 70% full so that one tank can receive WPA water. Water is to be used from WSTA 1 until it reaches empty (assumed to be 5% full), then valving is switched so that water is used from WSTA 2. When WSTA 2 is near empty plumbing is changed to draw water from WSTA 3 which should be filled by the WPA by that time.

3. ARS processes that affect the EAM water balance

ARS components that affect the water balance are the Condensing Heat Exchanger (CHX) which condenses water from the cabin atmosphere, the Pressure Control Subsystem (PCS) that requires water to produce O₂ (via electrolysis) for storage and crew use, the Carbon Dioxide Removal Assembly (CDRA) which removes CO₂ from the cabin and provides CO₂ (to recover O₂) via a Sabatier Reactor (SR) which combines CO₂ and H₂ to create water and Methane (CH₄). Water from the SR is assumed to be pure and thus compatible with the potable water supply thus it is sent to the WSTAs. CH₄ is vented in this version of the RTM.

The CHX is operated in the RTM by assuming that humidity in the cabin is removed at the rate that it is generated in the cabin (assuming the Thermal Control System is working nominally). The water separator not only separates condensate from air but pumps CHX collected water to the WPA WWTA.

CDRA operations are assumed to be nominal for collecting CO₂ from cabin air and thus maintaining CO₂ partial pressure within limits. Thus as CO₂ is added to the cabin by the crew it is removed by the CDRA and is sent to a CO₂ storage tank via a compressor. Compressed CO₂ is sent to the SR when the CO₂ tank reaches an upper limit and O₂ is being generated by the OGA. Since no storage of H₂ is currently assumed in the RTM (as in ISS), H₂ is vented if there is no CO₂ for the SR to use. Likewise if the CO₂ tank is full and no electrolysis is needed then excess CO₂ would be vented. To size the CO₂ tank, the RTM used logic that used nominal crew operations to predict the O₂ use rate and thus the time at which O₂ would need to be generated; then estimated the amount of CO₂ the CDRA would provide and sized the CO₂ collection tank so that it could reach its upper limit near the time that O₂ generation is required.

O₂ and N₂ tank sizing is based on ISS sizing (15.2 ft³ with Max Pressure of 2740 PSIA). OGA, CDRA and SR design and performance is based on ISS technology and operations (except that ISS restrictions related to sun/shade changes are not used for the EAM).

Operations of the ARS/PCS system use logic that starts SR operations after the CO₂ tank is full (reaches 95%) and O₂ makeup is required. Operations continue to use CO₂ and H₂ to provide water until the CO₂ tank is empty (assumed to be 5%). If the CO₂ tank is full but no O₂ generation is required CO₂ is vented until O₂ generation is required. If O₂ generation is required but no CO₂ is available, H₂ would be vented.

C. Test Mission definition

Since detailed mission operations plans are not established for exploration missions and are needed to test the RTM capabilities; a target mission was developed. To test the RTM, a nominal week of operations starting with crew arrival and occupation of the DSH was assumed. The crew timeline of water and food consumption, exercise, trash and metabolic waste generation was assumed. Tanks and provisions were loaded as anticipated for the start of a deep space mission. The EAM was assumed to provide all crew support for nominal activities.

Crew metabolic functions are defined via HIDH data shown in Table 1 and via the timeline of nominal crew activities that describes when the crew would drink, eat, exercise, use the commode and load the HMC with trash. Based on those nominal daily and weekly activities the waste water tanks are filled and the potable water tanks are depleted.

Automation of the rest of the RLS functions is assumed as related to the fill of tanks and the depletion of water and O2 resources. The RTM simulation provides the quantities in each consumable container as a function of time related to the metabolic rates and the operation of the RLS equipment.

Consumption Rate H2O	2.9		kg/crew/day
		2	kg/crew/day drinking
		0.5	kg/crew/day for food rehydration
		0.4	kg/crew/day for hygiene
Production Rate H2O Vapor	1.85		kg/crew/day
Production Average Rate Urine	1.696		kg/crew/day
		1.63	L of water/crew/day
		0.066	L of solids/crew/day
Fecal matter average	150		grams (by mass)
Average two defecations per day	2		
		150	mL (by volume) /crew/defecation
Feces will have an average		100	ml of water /crew/day (50 ml /crew/defecation)
Consumption Rate O2	0.82		kg/crew/day
Production Rate CO2	1.04		kg/crew/day
Food required	1.56		Kg/crew/day
Water in food consumed		0.72	Kg/crew/day
Table 1 Crew Metabolic Rates			

D. Water processing components of the RLS

The HMC operation has been simulated based on top level estimates of the amount of waste that the HMC can process and the amount of water contained in that waste. The portion of water reclaimed by the HMC via evaporation then condensation is based on the HMC performance data from testing (ref 7). Table 2 summarizes the HMC operations assumed including the timing of operations. The HMC planning is that a crew member will load the HMC with the compatible trash after the early meal. The crew will activate the HMC and the HMC will process the trash over the next 17.5 hours. The next day the HMC products will be removed and a new batch of trash will be loaded to begin the next batch.

HMC Operation

Solid Waste Storage capacity is assumed to be large enough for
Trash accumulated at a set rate.

HMC processes a portion of this trash for water extraction. The rest of the

Assume crew loads the HMC then operation is automated
Start loading at the end of the post sleep period (hour 3)
Loading takes around 20 minutes per day
Operate one time per day start at hour 3.5

Takes around 17.5 hours to process one batch
At a later time (long enough to complete operation including cool down) t
reloads with a new batch of trash

Water evaporation and subsequent condensation is automated
All condensed water is assumed to be near the quality of the UPA (CDS)
HMC water is flowed to the WPA waste water tank.

Parameters for the HMC
Average power during operation = 429 W
1.01 kg/crew/day of trash is produced and 35% is water = 0.35 kg/crew/day
Assume 80% recovery of water in the HMC wastes = 0.28 kg/crew/day
Average the recovery over the operational time of the HMC

Table 2 – Heat Melt Compactor assumptions and parameters

Much of the HMC data is based on the logistics database (Ref 2). The water removed from trash by the HMC is separated from the air stream via a separator that also provides the pumping power to move the condensate to the WPA WSTA.

E. WRS System Operations

The Commode (or Waste and Hygiene Compartment (WHC) performance is based on ISS WHC performance data. The ISS WHC mixes urine with 50 ml of condensate water (potable water on ISS) and 3 ML of pretreat for each use. Each use is estimated to take around 10 minutes during which time the fan/seperator is operating (when used during defecations it is assumed to operate for 20 minutes).

UPIX performance is simulated using the simplification that the UPIX removes around 0.5% of the urine/flush/pretreat/brine condensate flow. Removing Ca before CDS processes increases the capability of the CDS to recover a higher % of water from the waste stream.

Performance of the CDS is based on test data from 2014 (Ref 6). Operation of the CDS is started when the CDS WSTA reaches 95% full and continues until the WSTA reaches 5%.

BRIC operation performance is based on BRIC testing documented in Reference 8. The BRIC can recover 86% of the water in brine however, that water is expected to have some level volatiles that makes it useful to return it to the CDS instead of directly to the WPA. BRIC operations are started when the CDS WSTA reaches 90% full and stopped when the WSTA quantity reaches 5%. Solids removed by the BRIC are stored in solid waste storage.

WPA operation is based on ISS WPA performance as simplified by removing a % of the inlet waste water stream. The WPA is operated when the WWTA is filled to above 80% and is stopped when the WWTA quantity reaches 5%.

Tank capacities have been based on ISS tank sizes as in Table T below.

Table T – capacities of the WRS water and waste tanks (TBS)

Based on interactions with the WRS team storage tanks associated with urine and HMC condensate and CHX condensate storage were determined not to be needed. Instead flow of those streams is plumbed directly to tanks in the CDS or WPA. Those tanks can also receive flows while providing fluid to be processed simultaneously.

F. Air processing components of the RLS

The cabin condensing heat exchanger (CHX) performance is simplified to remove humidity at the rate it is input into the cabin. The CHX water separator operation provides the pumping power to send CHX condensate to the WPA.

OGA operation is based on ISS OGA capabilities as defined in the OGA Specification (ref 5). The rates are based on the specified requirement of providing 12 lb/day of O₂. However the use rate for the EAM is based on the spec. rate without adjustment for orbital sun/shadow periods that constrain ISS OGA operations. The continuous OGA operation results in a water use rate of 0.9 lb/hr. The OGA is to operate when the O₂ tank providing O₂ to the cabin reaches 50%. It continues to operate until the O₂ tank reaches 95% full. The OGA draws water from the potable water tanks. The H₂ produced is used by the SR to recover water or vented overboard if the SR is not operating.

Cabin CO₂ is removed by technology like the ISS CDRA. A simplifying assumption is that CO₂ is collected at the rate it enters the cabin. Collected CO₂ is compressed into a storage tank for use in the SR. The SR is operated when CO₂ stored is available and the OGA is operated to provide H₂. If the CO₂ tank is full but OGA operation is not required excess CO₂ is vented overboard.

Sabatier Reactor (SR) performance is based on testing (ref SR). The SR has been modeled in some detail in the RTM because the operation of SRs was a focus of ER simulation efforts. Methane (CH₄) produced by the SR is vented overboard. Water is separated from SR products by a separator that also provides the pumping of the water to the WPA WSTAs. The Sabatier reactor simulation in Trick/GUNNS is shown in Figure SR

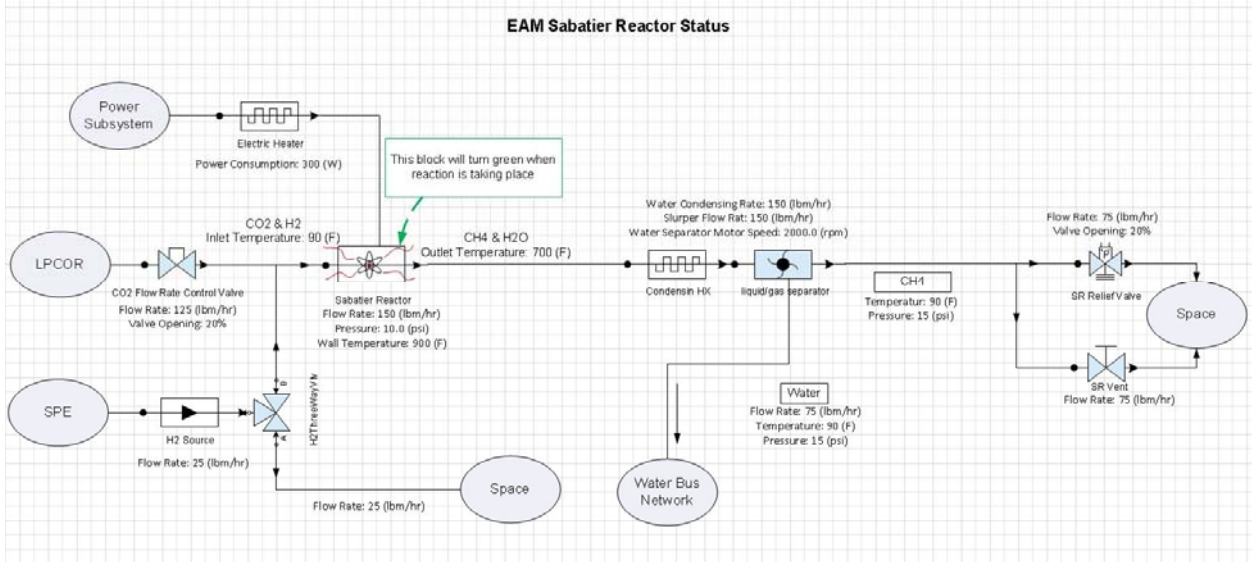

Figure SR – The Trick/GUNNS simulation for the Sabatier Reactor

Tank sizes for the variety of tanks of the ARS and PCS are based on ISS tanks sizes as shown in the following table.

Table PCS – tank sizes for ARS and PCS tanks of the EAM (TBS)

IV. Test Case Results

The operation of the WHC area is reflected in the flows of pretreated urine into the UPIX/CDS WSTA, the BRIC flows and the CDS flows. The crew use of the commode is reflected in the short duration flows thru the UPIX. BRIC operation is reflected in the much longer cycles that show that only two periods of operation of the BRIC are required during a week of nominal crew operations. Flows from the CDS to the WPA show that to happen 4 times during the week as determined by the CDS tank reaching its full limit.

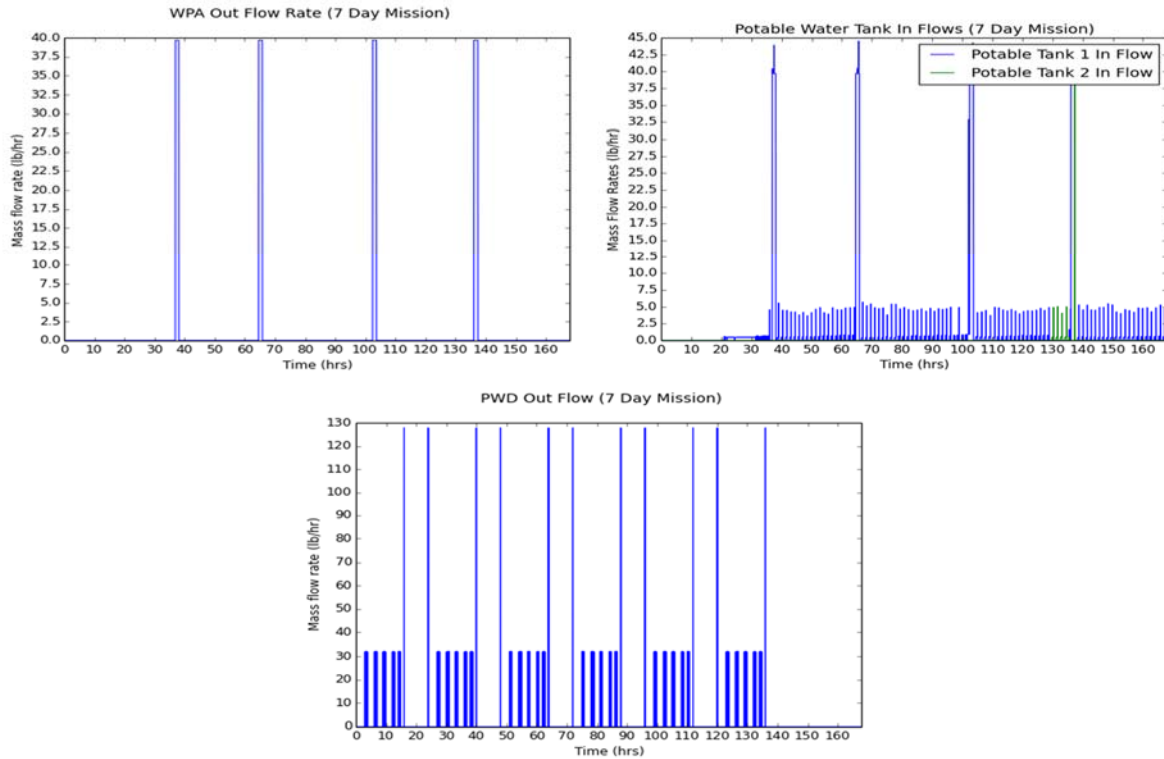

{Figure 3 Primary functions of the Commode, CDS and BRIC (page 40 from Mike's pitch)}

The operation of the HMC is reflected in the profiles of Figure 4. Flow of water is averaged over the operational period of the HMC as illustrated in the mass flow during each day of HMC operation. The saw tooth form of solid tank waste mass reflects the transient operation wherein trash acceptable to the HMC is taken from the trash mass and processed in the HMC then the solid part of the HMC is returned to solid waste storage.

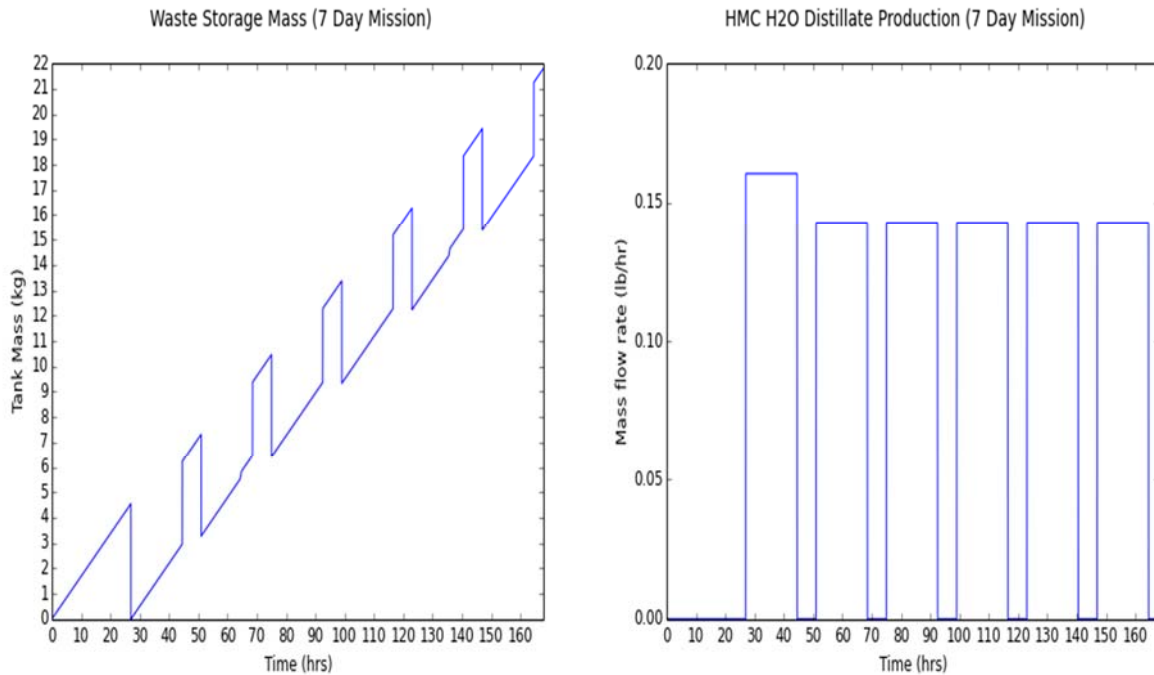

{Figure 4 – HMC and solid waste operations (page 41 from MM)}

WPA operations including periodic waste water processing potable water tank flows and PWD outlet flows are shown in Figure 5

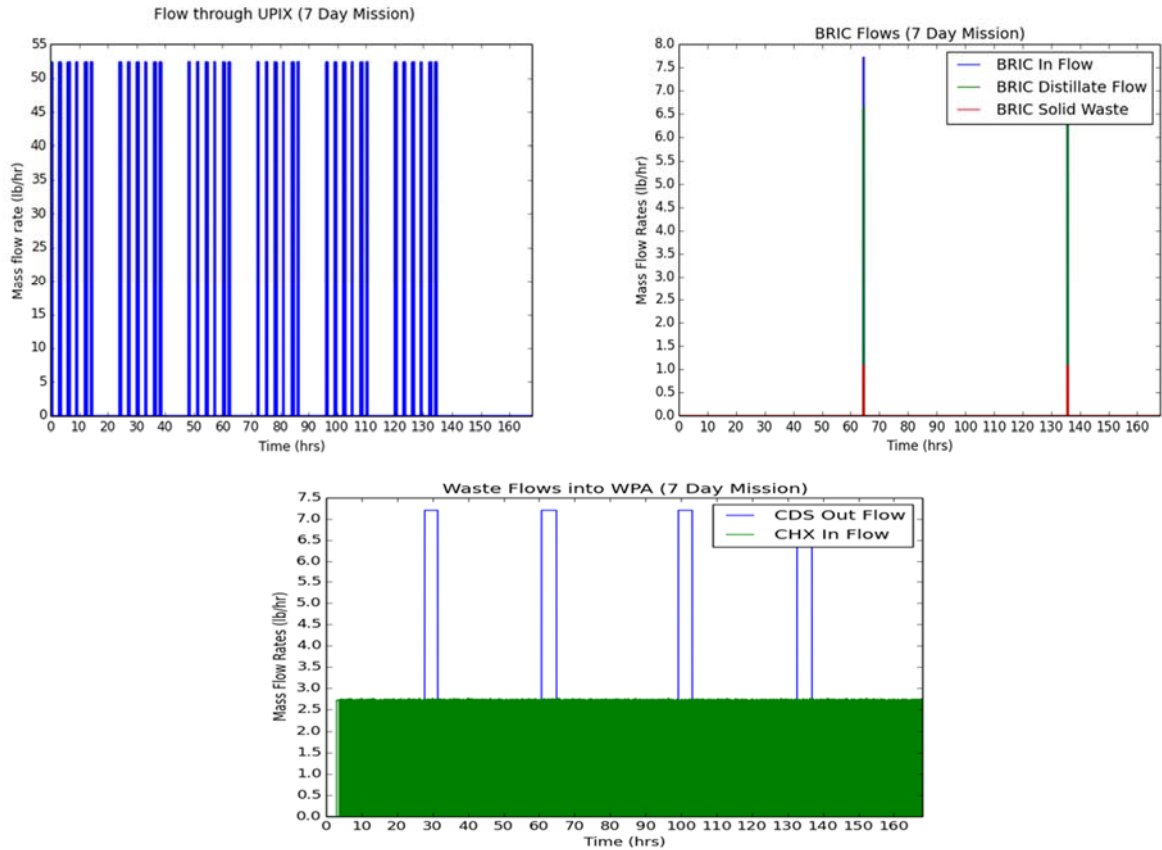

{Figure 5 – WPA and PWD water flows during a crew week (Chart 42 from MM)}

Figure 6 illustrates the interaction of the CDS, BRIC and WPA in the tank quantities for those systems. The timing of the fill operations that trigger operation of the CDS, BRIC and WPA is illustrated.

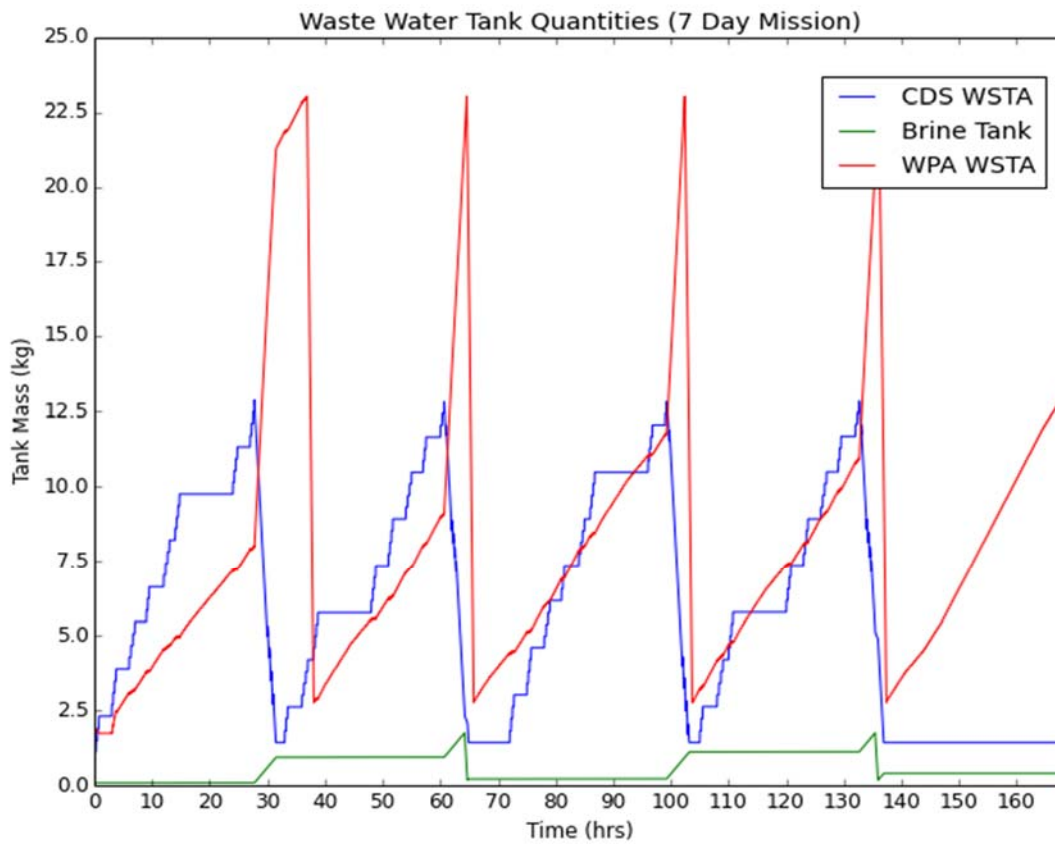

Figure 6 – Water tank quantities for the CDS, BRIC and WPA (chart 44 from MM)

The inventory of potable water is shown in figure 7 for the 3 potable water tanks. The integrated use and periodic operation of the WPA is reflected in the variations.

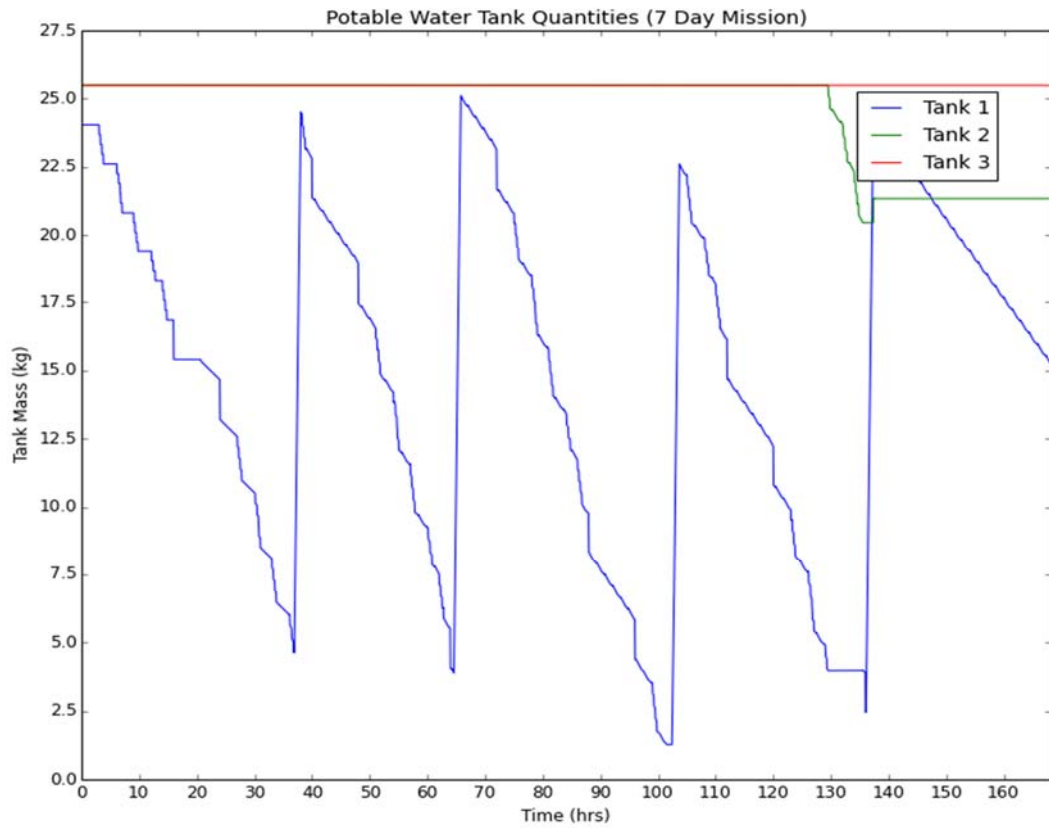

Figure 7 Potable Water Tank Quantities (Chart 45 from MM)

The flow of CO₂ into the cabin is shown in Figure 8. The assumption that CO₂ is removed as it enters the cabin results in a low CO₂ partial pressure of around 1.75 kPa.

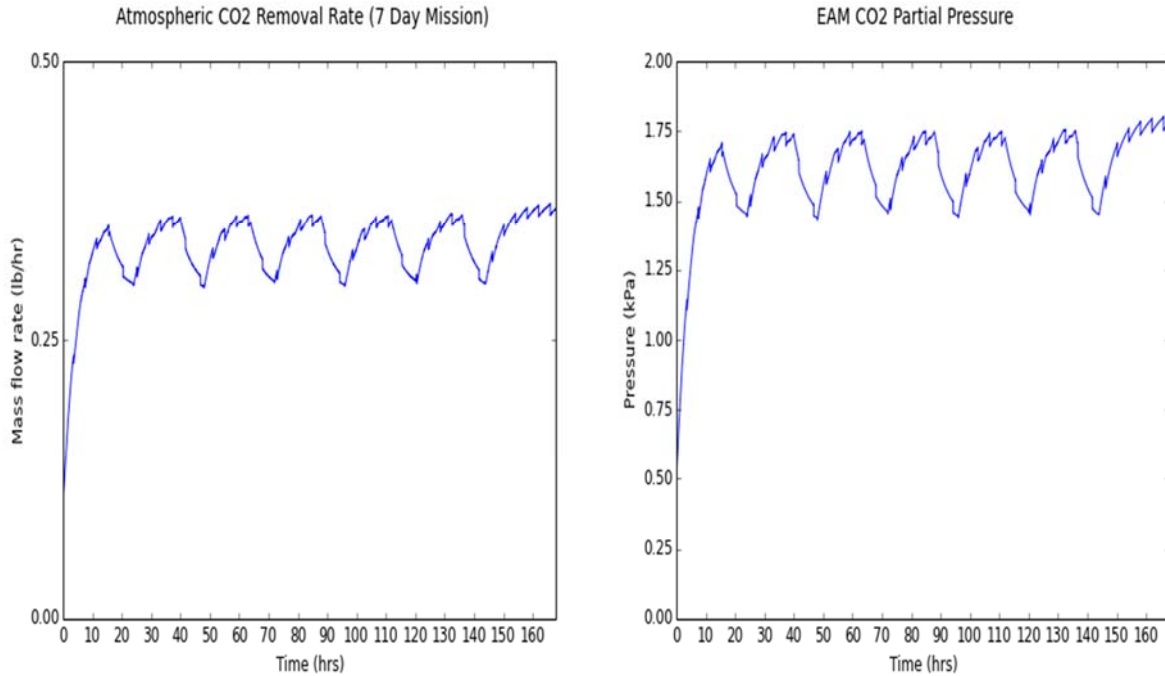

Figure 8 – Flow of CO2 from the cabin (chart 25 from MM)

Figure 9 illustrates the operation of the SPE and SR and the Crew use of O2. The SPE is activated when the O2 tank reaches its minimum limit and continues thereafter matching the crew O2 need. Once the SPE is operating and the CO2 tank has reached its upper limit the SPE and SR can begin to operate to react the CO2 and H2 to form H2O and CH4. The operation of the SPE and SR are reflected in the flows of H2O into the SPE (to electrolyze to form O2 and H2) and the flows of H2O out of the SR (as the product of the H2 and CO2 reaction). Venting of the H2 is also shown for periods when the CO2 quantity does not allow SR operation but O2 is required. The Specification H2O flow into the SPE (OGA) of 0.9 lb/hr is shown to be used for periods that the SPE is operational.

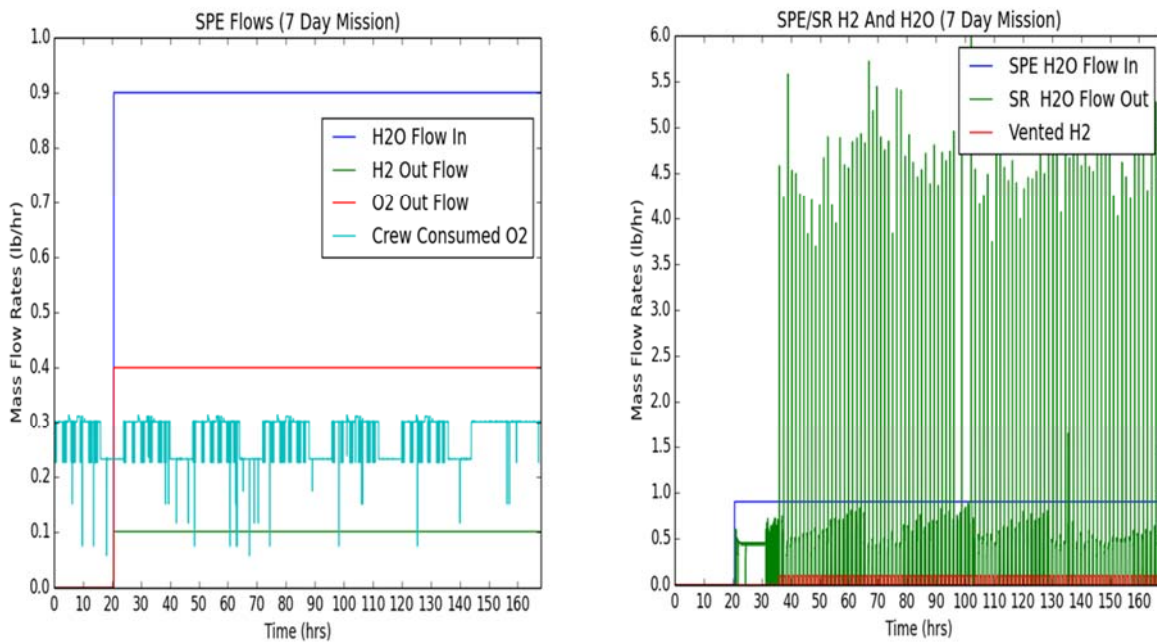

Figure 9 – SPE and SR flows associated with O2 generation and H2O recovery from CO2 and H2 (chart 27 from MM)

More details of the SR reactions are illustrated in Figure 10. The inlet H₂ and CO₂ flows as well as the outlet H₂O and CH₄ flows are shown.

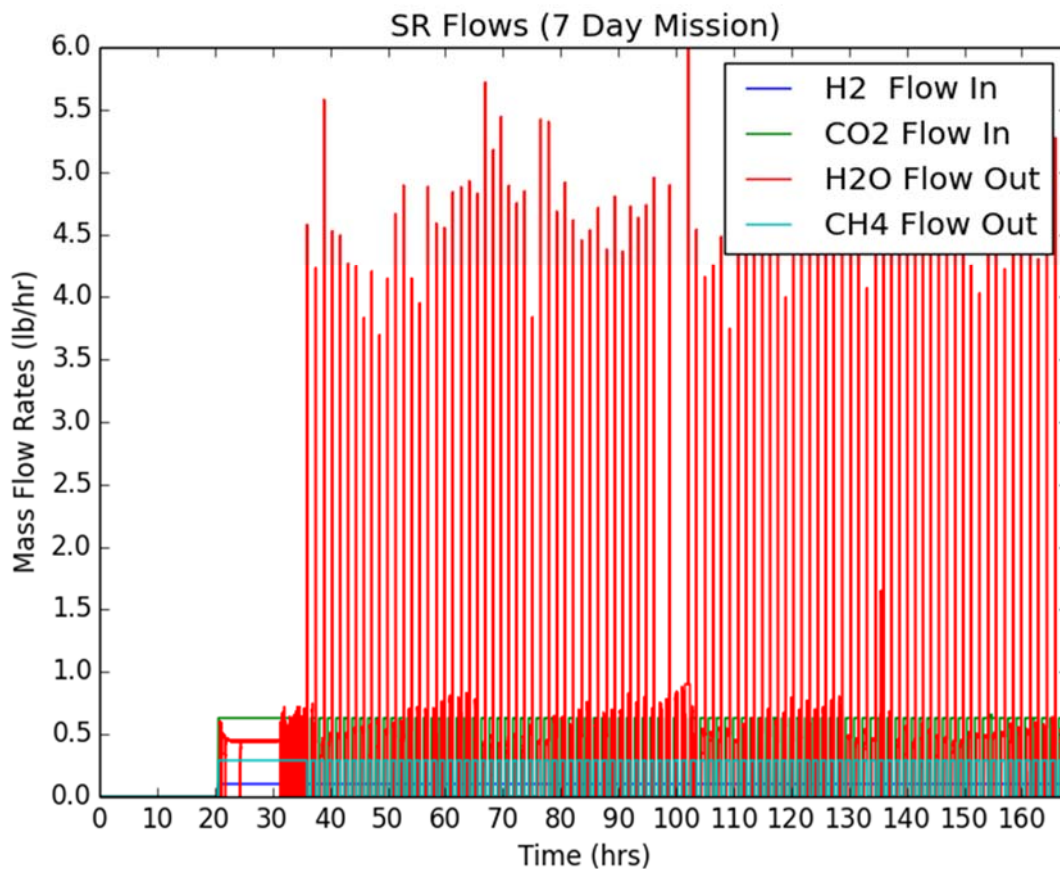

Figure 10 – SR inlet and outlet flows (chart 28 from MM)

A. Mass Balance of Water and O₂ during operation of the EAM

Viewing the balance of H₂O for the vehicle has to consider all the potential water processes since water will shift from one process to another during the operation of the vehicle. Additionally, the crew use of water has to consider several factors including drinking water and the water consumed via food. Movement of water around the vehicle will depend on operation of water collection in the commode via urine, condensate in the CHX and the HMC, and the recovery of water in the CDS and the WPA. Additionally, water used in the OGA to create Oxygen and water produced via the SR will move resources. Automated controls driven by logic for how to operate the equipment will determine when each of the recovery components operates based on tank quantities and related processes.

The RTM calculates where the inventory of water is at any time and illustrates how the water resource flows from the variety of components and storage tanks during the operation of the vehicle. A set of logic has been developed to check the mass balance based on the performance of the variety of components included in the RTM. The logic is implemented in an excel spreadsheet that uses component performance data to calculate the flow thru each component and how much of the resource is used or created during operation of the component. To check the mass balance, the spreadsheet tracks the flows thru each component based on the length of time the component is operated. The time the component is operated is determined by the Trick/GUNNS RTM based on the mission scenario and the resulting timing of operation of each component. Alternatively, the mass balance spreadsheet can be run by assuming the time of operation of each RLS component.

The mass balance spreadsheet has to consider all inputs and outputs to calculate the balance. Also it is expected that even RLS based life support systems will not balance inputs and outputs because there will be losses and inefficiencies that will result in loss of consumables.

The following are some of the factors that will result in mass loss from a vehicle even if the RLS the RTM simulates regenerates most resources:

- 1) Water will be lost in feces – the RTM currently assumes that feces is collected and not processed to recover water
- 2) Solids will be removed at a variety of points in the system and those will include a small amount of water.
 - a. The BRIC will remove a high % of the water in bine but the residual solids will have some water and will be waste products.
 - b. The UPIX will remove mainly Calcium but that small portion of the urine flow will be lost in the UPIX when it is replaced
 - c. The WPA will filter out a number of water impurities – when the WPA filters are replaced the filtered solids will be lost
 - d. The HMC will not recover 100% of the water in waste that it processes. The solids and residual water are lost as solid HMC products. Other solid waste products that are not processed in the HMC result in lost consumables.
- 3) Cabin atmosphere loss due to leakage – very small leak rates are allowed but that will result in loss of N₂, O₂, H₂O and CO₂
- 4) SR venting of CH₄ – the SR process included in the RTM will vent methane (other RLS technologies may recover some of that resource)
- 5) H₂ and CO₂ venting when tanks are full but scenarios don't allow use of those resources (electrolysis is not required to replenish O₂; CO₂ is not available when electrolysis is operating. Loss of H₂ or CO₂ could be minimized by adding a H₂ storage tank so that H₂ is available when CO₂ is also available)
- 6) Residual H₂O may be included in vented CH₄, or vented H₂ or vented CO₂ – separation processes are not 100% effective in separating water from other gases.
- 7) During EVAs consumable swill be lost during a variety of processes depending on the technology used. The amount will depend on the technology options used and how frequent EVAs are conducted. Those processes will be added to the RTM in future developments.
 - a. Processes to cool the suit and to remove H₂O and CO₂ may result in loss of those consumables
 - b. Waste products produced during EVAs may result in other consumables being lost (for example products like the MAGs).

However, the use of a RLS minimizes the loss of consumables. Loss of consumables must be addressed via provisions taken on exploration missions. Food, water, O₂, N₂ and many other consumables will be provided at the start of each mission. The amount will be determined based on crew size, mission length and technologies used in exploration vehicles. Simulation of missions using RTM will help in establishing the amount of each resource that must be provided to carry out each mission. Steady state assessments with programs such as ALLSAT will also aid in establishing the total of each consumable that will be needed.

The RTM provides the first program to provide estimates of where the major resources are within a vehicle using RLS. That information enables mission planners to monitor the fill state of the variety of systems in the vehicle to assess the overall operation of the vehicle. Thus the balance of the processes the vehicle employs can be monitored.

The RTM test mission results in the simulation of consumables reflected in Figure 11. The mass balance of the integrated operation of the RLS components of the EAM is illustrated showing that the flows of water in and out of components and the crew is essentially balanced even though the logic of operations shifts the water resource from one part of the vehicle to another over the week of nominal operations.

Figure 11 – Integration of all water sources and all water storage (requested summary plot not yet available).

V. Overview and Conclusions

To develop the RTM and simulate operations of an exploration vehicle required:

- 1) Developing a schematic of an Exploration vehicle RLS and a way to automate modeling based on VISIO schematics
- 2) Refining a habitat model to address anticipated crew metabolic processes, include food use, and include trash generation and processing
- 3) Modeling of each of the RLS components via data from ISS or advanced (but mature) new technologies (much of which has been done via data from recent ICES papers)
- 4) Sizing of the variety of tanks needed to store and then provide for processing H₂O, CO₂, O₂, and N₂
- 5) Defining a week of vehicle operations including the logic for operating RLS components

RTM modeling efforts have (for the first time) provided a tool to model the transient operation of a vehicle using a regenerative life support system. A week of operations has been simulated using the RTM to show how the integration of components will process water as connected to expected nominal crew operations. Results of that simulation provided insights into the interaction of RLS components and visualization of the transfer of resources between subsystems.

The Trick/GUNNS simulation environment has addressed the modeling of RLS equipment based on performance data of each component. Trick/GUNNS allows inclusion of more detailed component models if deemed relevant and as information becomes available.

VI. Future plans

The RTM has been established as a tool that can be used to simulate the transient operation of a vehicle using RLS technologies. It can be used to simulate mission scenarios using exploration vehicles employing RLS technologies to conserve limited resources.

The simulation of a nominal week of habitat operations has provided an example of the RTM capabilities. Future operation of the RTM is expected to address different mission operations to simulate a more complete exploration mission.

The RTM has been designed to allow object oriented exchange of data so that component descriptive data can be easily exchanged to allow simulation of alternative vehicle architectures. It is expected that system architectures envisioned for future exploration vehicles will consider other technologies and processes. RTM modeling in Trick/GUNNS will allow other architectures to be created by object oriented programming exchange of component data.

Interaction with the technology development community for ECLSS, WRS and Logistics will lead to refinement of the data used and potentially the architecture of the system that is modeled in the RTM. Interaction with the EAM project will lead to variations of the system architecture to be simulated and the missions to be addressed in future simulations of the RTM.

Evolution of the EVA simulation included in the RTM will lead to simulation capabilities for mission scenarios involving EVAs.

Interaction with technology developers and mission planners will lead to refinement of the RTM mission operations.

The RTM has provided the first transient simulation capability of an exploration vehicle integrated regenerative life support system. It will be used for the variety of simulation needs that technology developers and mission planners develop for exploration missions.

References

- 1) Liskowsky, David R.; Seitz, William W.; "HUMAN INTEGRATION DESIGN HANDBOOK (HIDH)"; NASA Document NASA/SP-2010-3407/REV1, 06-05-2014.
- 2) Ewert, Michael K., and Broyan, James Lee, Jr.; "Mission Benefits Analysis of Logistics Reduction Technologies", AIAA Paper AIAA 2013-3383, International Conference on Environmental Systems (ICES); July 14-18, 2013, Vail, CO.CDS paper
- 3) BVAD
- 4) CDRA
- 5) OGA
- 6) CDS
- 7) Harry W. Jones, Greg Pace, John W. Fisher, "Managing Spacecraft Waste Using the Heat Melt Compactor (HMC)", Paper # AIAA 2013-3362; 43rd International Conference on Environmental Systems, 2013
- 8) BRIC
- 9) Visio

- 10) SmsML
- 11) Trick/GUNNS
- 12) Mars Surface Habitat (Hanford
- 13) EASY5
- 14) ALLSAT
- 15) G189A
- 16) Thermal Desktop
- 17) EAM